



DEPARTMENT OF CITY PLANNING

RECOMMENDATION REPORT

City Planning Commission

Date:	Thursday, May 11, 2023	Case No.:	CPC-2022-7047-CU-DB-SPR-HCA
Time:	After 8:30 a.m.*	CEQA No.:	ENV-2020-7048-CE
Place:		Incidental Cases:	N/A
		Related Cases:	N/A
		Council No.:	11-Park
		Plan Area:	Hollywood
Public Hearing:	February 7, 2023	Specific Plan:	N/A
Appeal Status:	Density Bonus Off-menu incentives are not further appealable. Conditional Use and Site Plan Review are appealable to City Council.	Certified NC:	Central Hollywood
		Zone:	C2-1D
		Applicant:	Vine Street Los Angeles Apartments, LLC
Expiration Date:	May 11, 2023	Representative:	Dana Sayles, threesixty
Multiple Approval:	Yes		

PROJECT LOCATION: 1200-1218 North Vine Street and 6245-6247 West Lexington Avenue

PROPOSED PROJECT: The proposed project includes the demolition of two existing commercial buildings and one surface parking lot for the construction of a new seven-story mixed-use building with 151 dwelling units (17 units set aside for Very Low Income Households). The proposed building is 87 feet in height and has 143,295 square feet of floor area. The project includes 3,690 square feet of commercial ground floor uses and 87 vehicle parking spaces.

REQUESTED ACTIONS:

- 1) Pursuant to CEQA Guidelines, Section 15332, Class 32, an Exemption from CEQA, and that there is no substantial evidence demonstrating that an exception to a categorical exemption pursuant to CEQA Guidelines, Section 15300.2 applies;
- 2) Pursuant to Los Angeles Municipal Code (LAMC) Section 12.24-U,26, a Conditional Use Permit to allow a Density Bonus for a housing development project in which the density increase is greater than otherwise permitted by LAMC Section 12.22-A,25; and
- 3) Pursuant to LAMC Section 12.22-A,25, a Density Bonus to permit a housing development project consisting of 151 dwelling units, of which 17 will be set aside for Very Low Income households, requesting the following Incentives:
 - a. Off-Menu Incentive to permit an increase in Floor Area to allow an FAR of 3.5:1 in lieu of the otherwise required 0.5:1 FAR in the C2-1D Zone; and
 - b. Off-Menu Incentive to permit a decrease in the required rear yard to allow 10 feet in lieu of the 20 foot rear yard required in the C2-1D Zone; and

- c. Off-Menu Incentive to permit a decrease in required side yard along Vine Street to allow zero (0) feet in lieu of the 10 foot side yard required in the C2-1D Zone.
- 4) Pursuant to LAMC Section 16.05, a Site Plan Review for a project that results in an increase of 50 or more dwelling units and/or guest rooms.

RECOMMENDED ACTIONS:

- 1) **DETERMINE**, that based on the whole of the administrative record, the Project is exempt from CEQA pursuant to CEQA Guidelines, Section, 15332, and there is no substantial evidence demonstrating that an exception to a categorical exemption pursuant to CEQA Guidelines, Section 15300.2 applies.
- 2) **Approve** a Conditional Use Permit to allow a Density Bonus pursuant to LAMC Section 12.24-U,26 for a housing development project in which the density increase is greater than otherwise permitted by LAMC Section 12.22-A,25;
- 3) **Approve** a Density Bonus Compliance Review, pursuant to LAMC Section 12.22.A.25, to permit a housing development project consisting of 151 dwelling units, of which 17 units will be set aside for Very Low Income households and with the following Incentives:
 - a. Off-Menu Incentive to permit an increase in Floor Area to allow an FAR of 3.5:1 in lieu of the otherwise required 0.5:1 FAR in the C2-1D Zone;
 - b. Off-Menu Incentive to permit a decrease in the required rear yard to allow 10 feet in lieu of the 20 foot rear yard required in the C2-1D Zone;
 - c. Off-Menu Incentive to permit a decrease in required side yard along Vine Street to allow zero (0) feet in lieu of the 10 foot side yard required in the C2-1D Zone.
- 4) **Approve** a Site Plan Review, pursuant to LAMC Section 16.05, for a project that results in an increase of 50 or more dwelling units and/or guest rooms.
- 5) **Adopt** the attached Conditions of Approval and Findings;

VINCENT P. BERTONI, AICP
Director of Planning



Heather Bleemers
Senior City Planner



Renata Ooms
City Planner

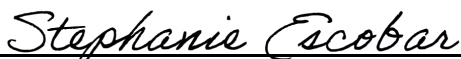

Stephanie Escobar, Stephanie.Escobar@lacity.org
City Planning Associate

ADVICE TO PUBLIC: *The exact time this report will be considered during the meeting is uncertain since there may be several other items on the agenda. Written communications may be mailed to the *Commission Secretariat, Room 272, City Hall, 200 North Spring Street, Los Angeles, CA 90012* (Phone No. 213-978-1300). While all written communications are given to the Commission for consideration, the initial packets are sent to the week prior to the Commission's meeting date. If you challenge these agenda items in court, you may be limited to raising only those issues you or someone else raised at the public hearing agendized herein, or in written correspondence on these matters delivered to this agency at or prior to the public hearing. As a covered entity under Title II of the Americans with Disabilities Act, the City of Los Angeles does not discriminate on the basis of disability, and upon request, will provide reasonable accommodation to ensure equal access to these programs, services and activities. Sign language interpreters, assistive listening devices, or other auxiliary aids and/or other services may be provided upon request. To ensure availability of services, please make your request not later than three working days (72 hours) prior to the meeting by calling the Commission Secretariat at (213) 978-1299.

TABLE OF CONTENTS

Project Analysis	A-1
Project Summary	
Project Background	
Requested Entitlements	
Public Hearing	
Project Considerations	
Conclusion	
Conditions of Approval	C-1
Findings	F-1
Conditional Use Findings	
Density Bonus / Affordable Housing Incentives Compliance Findings	
Site Plan Review Findings	
Public Hearing and Communications	P-1
Exhibits:	
Exhibit A – Plans	
Exhibit B – Environmental Documents (ENV-2022-7048-CE)	
Appendices	
Tree Report	
Transportation Assessment	
LADOT Approval Letter	
Noise Report	
Air Quality Report	
Water Resources Report	
Response from Recreational and Parks Services	
Water and Wastewater Report	
Geotechnical Investigation	
LADBS Approval Letter	
Exhibit C – Maps (Vicinity and Radius)	
Exhibit D – Site and Surrounding Area Photos	
Exhibit E – Public Correspondence	
Exhibit F – CAJA Environmental Services - Response to CEQA Comments, April 13, 2023	
Exhibit G – Departmental Letters	

PROJECT ANALYSIS

PROJECT SUMMARY

The proposed project includes the demolition of two commercial buildings and a surface parking lot for the construction of a new seven-story, mixed-use residential building containing 151 dwelling units with 17 units set aside for Very Low Income Households (16% of the base density). The project will reach 87 feet in height and will have 143,295 square feet of floor area for a maximum Floor Area Ratio (FAR) of 3.5:1. The project includes 3,690 square feet ground floor of commercial uses and 87 vehicle parking spaces within two levels of above grade parking. Renderings are shown in Figures 1 and 2 below.



Figure 1. Rendering of proposed project from Lexington Avenue.



Figure 2. Rendering of Proposed Project with view of Vine Street frontage.

The ground floor features commercial space wrapping the corner at Vine Street and Lexington Avenue and a pedestrian plaza along Lexington Avenue. Ground floor pedestrian amenities include a lobby, entry garden, leasing office, mail room and bike room. The second floor features a pool room, 1,360 square feet of co-working space, 255 square feet of co-working garden space, a 780 square foot amenity space, residential units, two (2) stores, and parking. The third floor houses the building's club lounge and fitness center, as well as a mix of residential units. The fourth through seventh floors contain a mix of residential units. There are also two roof decks located on the seventh floor. From the third floor to the seventh floor the building interior has been carved out facing Lexington Avenue to recess the units along the north, east, and west of the building. This recess provides the interior units with light and air.

The project's floor area will include 3,690 square feet of retail uses, 3,660 square feet of lobby and leasing space, 1,220 square feet of fitness room, 1,100 square feet of club rooms, 102,876 square feet of residential uses and 4,015 square feet of other amenities.

The Project provides 87 total parking spaces, with 80 residential spaces and seven (7) commercial spaces. The building includes parking on the first and second levels. Figure 3 below shows how parking is buffered from street view as it is situated behind the commercial and amenities and residential units that front Vine Street and Lexington Avenue. Parking can be accessed from egress/ingress driveways on Vine Street and Lexington Avenue.

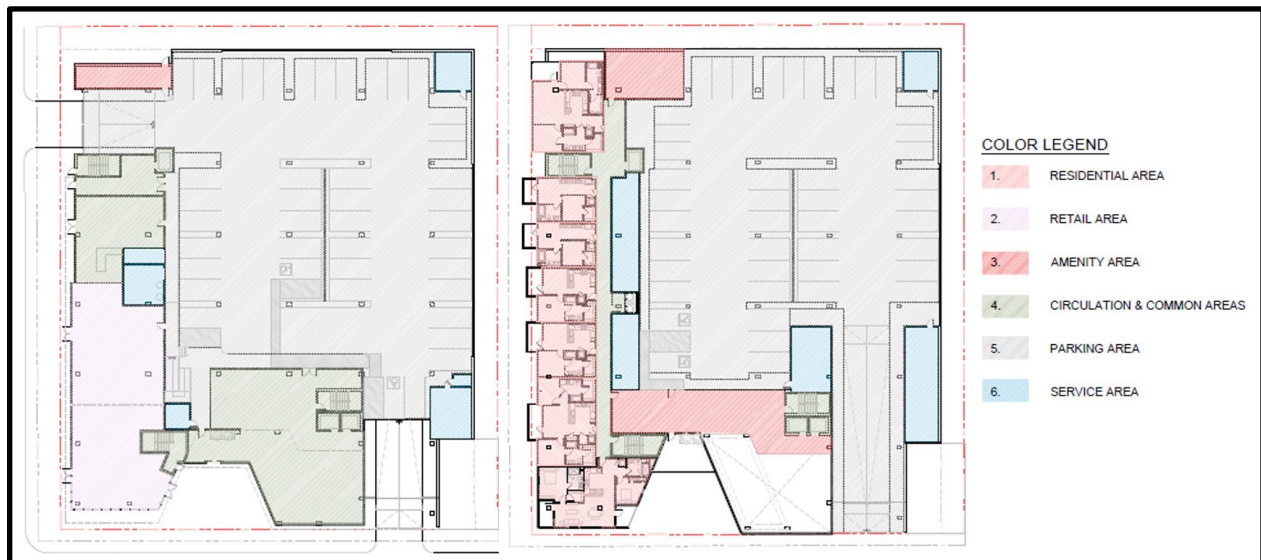

Figure 3. Site Plan. Ground Floor (left) and Second Floor (Right). Showing active uses along the street frontages and the parking area at the rear of the building.

The project provides a total of 19,065 square feet of open space, including indoor and outdoor amenities for residents and the surrounding community. The Project provides a 1,200 square foot pedestrian plaza along Lexington Avenue to complement the commercial uses at the ground level and integrate the Project at the street level. Open space accessible to residents includes a 5,970 square foot courtyard on the third floor, as well as two open-air roof decks on the seventh floor containing 1,200 square feet and 620 square feet. There is also 4,025 square feet of indoor amenities including a fitness center, club room, and co-working space. Additionally, the Project proposes 38 new on-site trees to be accommodated throughout the project, meeting the LAMC requirement of one tree for every four dwelling units.

PROJECT BACKGROUND

Project Site

The subject property is a rectangular-shaped site comprised of five parcels, measuring 40,787 square feet (0.9 acres). The property is located at a street corner and fronts approximately 198 feet along Vine Street, and 173 feet and six (6) inches feet along Lexington Avenue. The site is currently improved with two commercial buildings and a surface parking lot (see Figure 4 below). The property does not contain any existing residential housing units.

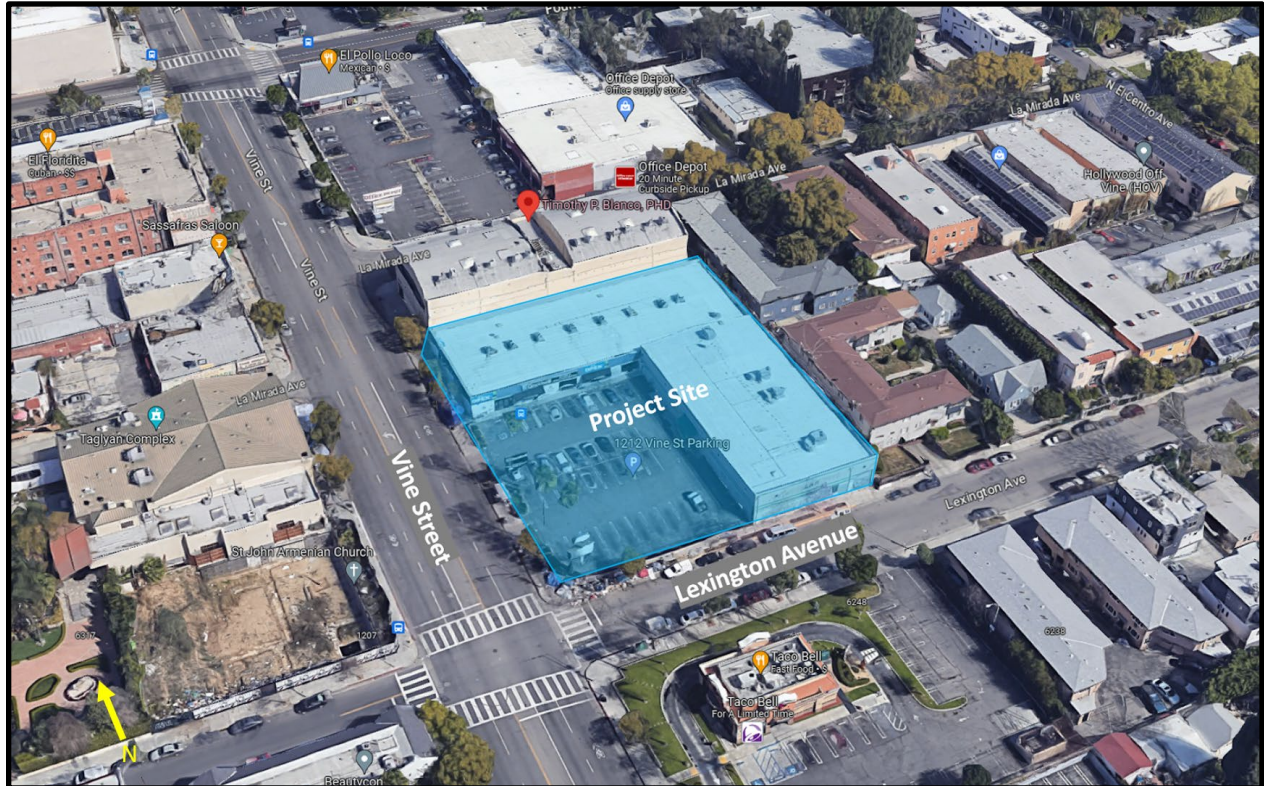

Figure 4. Aerial view of site and surrounding area. Google Maps.

General Plan Land Use Designation and Zoning

The project site is located within the Hollywood Community Plan, which is one of 35 Community Plans which together form the land use element of the General Plan. The Community Plan designates the site for Highway Oriented Commercial land uses with corresponding zones of C1, C2, P, RAS3 and RAS4. The project site is zoned C2-1D (as shown in Figure 5) and is thus consistent with the existing land use designation. The C2 Zone permits Residential uses at a density of one dwelling unit per 400 square feet of lot area. Height District 1 in commercial zones has no limit on height or stories with a maximum base Floor Area Ratio (FAR) of 1.5:1. However, the "D" Limitation on the Property restricts the FAR to 0.5:1. Notably, projects subject to Commercial Corner development standards are limited to 45 feet in height, but mixed-use projects are exempt from Commercial Corner requirements and are unlimited by height and stories.

Additionally, the subject site is also located within a Los Angeles State Enterprise Zone, a Transit Priority Area in the City of Los Angeles, a Housing Element Inventory of Sites zone, a Local Emergency Temporary Regulations for Time Limits and Parking Relief and the Revised Hollywood Community Plan Injunction.

Residential and are developed with a fast food restaurant and two-story apartment building. Properties to the west, across Vine Street, are zoned C2-1D with a land use designation of Highway Oriented Commercial and are developed with a church (St. John Armenian Church) as well as a vacant dirt lot located at the northwest corner of Lexington Avenue and Vine Street.

Streets

Vine Street, adjoining the Property to the west, is a designated Avenue II, dedicated to approximately 92.5 feet in width at this location with a 50-foot half roadway. Vine Street is required to have a 86-foot total public right-of-way dedication, or a 43-foot half roadway.

Lexington Street, adjoining the Property to the south, is a designated Local Street - Standard, dedicated to approximately 60 feet in width at this location. Lexington Street is required to have a 60-foot total public right-of-way dedication, or a 30-foot half roadway.

Relevant Cases

Subject Property:

There are no relevant cases on the subject property.

Surrounding Properties:

The following relevant cases were identified to be within a 1,000-foot radius of the project site and filed within the past 10 years:

Case No. CPC-2020-3253-DB-SPR-HCA: On November 1, 2022, the City Planning Commission approved a new five-story and a new six-story residential building with a total of 169 units of which 19 will be reserved for Very Low Income households. The project provides 278 parking spaces within three subterranean parking levels located at 1121-1149 Gower Street, 6124 West Lexington Avenue, and 1124-1150 North Lodi Place.

Case No. CPC-2014-4279-ZC-HD-ZAA-SPR: On August 11, 2016, the City Planning Commission approved a seven-story residential mixed-use building ranging from approximately 82 feet to 110 feet in height, that will provide 369 residential units, including 12 live/work units, 30 micro units and 20 units for Moderate Income households, and approximately 2,570 square feet of commercial space on the ground floor, 40,900 square feet of open space, including a ground floor plaza accessible to the public, an outdoor recreation deck on the 2nd floor, a roof terrace on the 7th floor, a covered deck on the 2nd floor, a gym and recreation room. The project will include 567 parking spaces and 410 bicycle parking spaces within a two-level subterranean garage, at ground level within the building, and in the mezzanine level above-grade located at 1310-1322 North Cole Avenue, 6400-6418 West Homewood Avenue; 6407-6417 West Homewood Avenue; 1311-1347 North Cahuenga Boulevard; and 6401-6423 West Fountain Avenue.

Case No. DIR-2014-3620-DB: On November 10, 2015, the Director of Planning approved a new three-story, 40.5-foot in height, and 33, 138 square foot multi-family complex with 29 units and a semi-subterranean and subterranean parking garage, on two lots with a lot area of 16,800 square feet located at 1142-1150 North Cahuenga Boulevard.

Density Bonus / Affordable Housing Incentive Program

In accordance with California Government Code Section 65915 and LAMC Section 12.22-A,25, in exchange for setting aside a minimum percentage of the project's units for affordable housing, the project is eligible for a density bonus, reduction in parking, and incentives allowing for relief from development standards. The applicant has requested to utilize the provisions of City and State Density Bonus laws as follows:

Density

The subject property is zoned C2-1D, which limits density to one (1) dwelling unit per 400 square feet of lot area. The subject property has a total lot area of 40,786 square feet, and as such, the permitted base density on the subject property is 102 units.¹ In exchange for reserving a portion of the units for affordable housing, the applicant is entitled to a maximum 35 percent density bonus by-right. The applicant is seeking an additional 12.5 percent density bonus (or a total of a 47.5 percent density bonus) through a Conditional Use to allow for the proposed 151 dwelling units to be built on the site.

Pursuant to the LAMC and California Government Code Section 65915, a Housing Development Project that sets aside a certain percentage of units as affordable, either in rental or for-sale units, shall be granted a corresponding density bonus, up to a maximum of 35 percent. While these provisions are limited to 35 percent, Government Code Section 65915(f) states that "the amount of density bonus to which an applicant is entitled shall vary according to the amount by which the percentage of affordable housing units exceeds the percentage established." As such, in instances where a project is seeking a density bonus increase that is more than 35 percent, the amount of required units that are set aside as affordable shall vary depending on the requested amount of density bonus. Therefore, it is appropriate that any project that requests a density bonus increase beyond 35 percent would extend the existing set-aside charts located in Section 12.22-A,25 of the LAMC. Section 12.24-U,26 of the LAMC, which implements this provision of State law, states that a project may be granted a Conditional Use Permit for additional density increases beyond the 35 percent maximum by providing additional affordable housing units. Consistent with this Section, Table 1 below illustrates how the maximum allowable Density Bonus increases for every unit set aside for Very Low Income Households (2.5 percent density increase for every additional one [1] percent of Very Low Income units provided), based on the base density and the chart prescribed in LAMC Section 12.22-A,25.

Table 1: Density Bonus Percentages

Very Low Income Units (Percentage of Base Density)	Maximum Density Bonus Permitted (Based on Base Density)
5 %*	20 %*
6 %*	22.5 %*
7 %*	25 %*
8 %*	27.5 %*
9 %*	30 %*
10 %*	32.5 %*
11 %*	35 %*
15 %	45%
16 %	47.5 %

*Existing set-aside chart as listed in Section 12.22-A,25 of the LAMC

¹ Assembly Bill 2501 clarifies that density calculations that result in a fractional number are to be rounded up to the next whole number. This applies to base density, number of bonus units, and number of affordable units required to be eligible for the density bonus.

For the subject property, a 35 percent by-right density bonus would allow for 138 units (equal to an increase of 36 units beyond the 102 base density) to be constructed on the project site. As illustrated in Table 1 above, in order to qualify for the 35 percent by-right density bonus, the project would be required to set aside 11 percent of the base density, or 11 units, for Very Low Income Households. The applicant is seeking an additional 12.5 percent density bonus (for a total of a 47.5% density bonus from the base density) through a Conditional Use to allow for a total of 151 dwelling units, representing an increase of 13 units beyond what would otherwise be permitted through the by-right 35 percent density bonus. In order to obtain the additional requested 12.5 percent density bonus, as shown in Table 1, the project must set aside at least 16 percent of the base density, equal to 17 units, for Very Low Income units. The project will provide 17 units for Very Low Income households in exchange for the requested Density Bonus. As such, the Density Bonus request results in 138 units and the Conditional Use request results in an additional 13 units for a total of 151 dwelling units with 17 affordable units.

Incentives

Pursuant to the LAMC and Government Code Section 65915, the applicant is entitled to three Incentives, in exchange for reserving at least 16 percent of the base density for affordable households. The proposed project will set aside 17 units, equal to 16 percent of the base number of units, for affordable households. Accordingly, the applicant has requested three (3) Incentives:

- 1. Floor Area Increase (Off-Menu)** - The subject property is zoned C2-1D. Height District 1 in commercial zones has no limit on height or stories (commercial only uses are limited to 45 feet pursuant to Commercial Corner development standards, however mixed-use projects are exempt and unlimited by height and stories), with a maximum base Floor Area Ratio (FAR) of 1.5:1. However, the "D" Limitation on the Property restricts the FAR to 0.5:1. Thus, Pursuant to LAMC Section 12.22-A,25 the applicant is requesting an Off-Menu incentive to allow a FAR increase from 0.5:1 to 3.5:1 to allow 143,295 square feet in floor area.
- 2. Rear Yard Reduction (Off-Menu)** - The subject property is zoned C2-1D, which requires a 20 foot northerly rear yard. Per LAMC Section 12.22-A,25, the applicant is requesting an Off-Menu incentive to permit a 10 foot rear yard setback in lieu of the otherwise required 20 foot rear yard setback; and
- 3. Side Yard Reduction (Off-Menu)** - The subject property is zoned C2-1D, which requires the project to have a 10 foot side yard. Per LAMC Section 12.22-A,25(f), the applicant is requesting an Off-Menu incentive to allow a reduction in side yard setbacks along Vine Street to allow zero feet in lieu of the otherwise required 10 feet side yard setback.

Housing Replacement

On October 9, 2019, the Governor signed into law the Housing Crisis Act of 2019 (SB 330). SB 330 creates new state laws regarding the production, preservation and planning for housing, and establishes a statewide housing emergency until January 1, 2025. During the duration of the statewide housing emergency, SB 330, among other things, creates new housing replacement requirements for Housing Development Projects by prohibiting the approval of any proposed housing development project on a site that will require the demolition of existing residential dwelling units or occupied vacant "Protected Units" unless the proposed housing development project replaces those units.

The Housing Crisis Act of 2019, as amended by SB 8 (California Government Code Section 66300 et seq.), prohibits the approval of any proposed housing development project on a site that will require demolition of existing dwelling units or occupied or vacant "Protected Units" unless the project replaces those units. The project shall provide at least as many residential dwelling units

as the greatest number of residential dwelling units that existed on the property within the past five years. Additionally, the project must also replace all existing or demolished “Protected Units.”

Pursuant to the Housing Replacement Determination made by the Los Angeles Housing Department (LAHD) dated July 1, 2022, the proposed site has been developed with commercial uses since at least 2017 and thus has no existing residential units on site and is not subject to replacement unit requirements.

PUBLIC HEARING

A public hearing on this matter with the Hearing Officer and Deputy Advisory Agency virtually via zoom meeting on Tuesday, February 7, 2023. Comments from the public hearing are documented in Public Hearing and Communications, Page P-1.

PROJECT CONSIDERATIONS

Hollywood Community Plan Update

On April 24, 2023 the Planning and Land Use Management Committee of the City Council recommended approval of the proposed Hollywood Community Plan Update. As of the drafting of this Report, the Community Plan update is scheduled for City Council on May 3, 2023. Should the City Council adopt the proposed updated Community Plan for Hollywood prior to CPC’s action on this entitlement request, please note that the subject entitlement request has been Deemed Complete and thus is not subject to the updated Community Plan. Nonetheless, the project generally conforms to the polices, proposed zoning and proposed design standards of the updated Hollywood Community Plan and the proposed Community Plan Implementation Overlay (CPIO).

Professional Volunteer Program

The proposed project was reviewed by the Urban Design Studio’s Professional Volunteer Program (PVP) on December 13, 2022. The following issues, concerns, and recommendations were discussed:

The Professional Volunteer Program appreciated the design of the project, as it is appropriate for an area dense with medium residential housing and commercial uses. The PVP commented that the project has implemented preferred urban design practices. The PVP also commented that the project incorporated a well-considered relationship between the indoor and outdoor amenity spaces and also commended the project’s preservation of existing street trees.

The PVP also made suggestions to improve the proposed project. The PVP was pleased to see that the project’s bicycle room has direct access from the public realm but suggested that the applicant indicate the transparency on the elevations. The PVP suggested that the applicant make the necessary revisions to the submitted elevation plans to demonstrate what materials and colors will be utilized for the project. While there is no parking visible along Vine Street or Lexington Avenue, the PVP asked the applicant to provide details on the materiality utilized to screen for the above grade parking levels that are located along the secondary building facades. The PVP also asked the applicant to provide more LID-compliance details in the landscape plans as well as change the proposed “Dracaena Draco” plant species with a plant species that satisfies the City’s tree requirements.

On April 11, 2023, the applicant submitted revised plans to address the PVP’s comments. The revised plans (stamped Exhibit A) now call out the materiality of the project on the elevations. The exterior of the bicycle room will have a floor to ceiling dark bronze storefront which is a type of

glass. The revised elevations also address the materiality of the screening used for the above grade parking located on the eastern side of the building. Parking is screened using modern perforated metal paneling. Page A8-0 and L2-1 of the Exhibit A shows an image of proposed materials. Additionally, the applicant replaced the “Dracaena Draco” plant species with a plant species that satisfies the City’s tree requirements.

CONCLUSION

Based on the public hearing and information submitted to the record, staff recommends that the City Planning Commission find, based on its independent judgment, after consideration of the entire administrative record, that the project is categorically exempt from CEQA. Staff also recommends that the City Planning Commission approve the Density Bonus incentives and waivers of development standards and the Conditional Use for an additional 12.5 percent density bonus (for a total of 47.5% density bonus from the base density), thereby approving the project as proposed. The project will result in 151 net new housing units and will not demolish any existing housing. The approval of the density bonus, conditional use, and site plan review will allow the addition of 17 Very Low Income Households, 134 market rate units, and new retail uses in a neighborhood that is characterized as walkable and rich in job opportunities which aligns with the City’s housing and economic development goals and objectives. The project is designed to enhance the public realm and activate a prominent corner in Hollywood with retail uses and a public plaza (see Figure 6 below).



Figure 6: Street view of proposed project from the corner of Vine Street and Lexington Avenue

CONDITIONS OF APPROVAL

Pursuant to Sections 12.22-A,25, 12.24-U,26 and 16.05 of the Los Angeles Municipal Code, the following conditions are hereby imposed upon the use of the subject property:

A. Development Conditions

Density Bonus

1. **Site Development.** Except as modified herein, the project shall be in substantial conformance with the plans date 4/11/2023, submitted by the Applicant, stamped "Exhibit A," and /attached to the subject case file.
2. **Residential Density.** The project shall be limited to a maximum density of 151 dwelling units.
3. **Affordable Units.**
 - a. A minimum of 17 units, that is at least 16 percent of the base dwelling units permitted in the C2-1D Zone, shall be reserved as Very Low Income Households, as defined by the State Density Bonus Law per Government Code Section 65915(c)(2).
 - b. **Changes in Restricted Units.** Deviations that increase the number of restricted affordable units or that change the composition of units or change parking numbers shall be consistent with LAMC Section 12.22-A,25.
4. **Housing Requirements.** Prior to issuance of a building permit, the owner shall execute a covenant to the satisfaction of the Los Angeles Housing Department (LAHD) to make at least 16 percent of the site's base density units (102 units) available to Very Low Income Households, for sale or rental as determined to be affordable to such Households by LAHD for a period of 55 years. In the event the applicant reduces the proposed density of the project, the number of required reserved on-site Restricted Units may be adjusted, consistent with LAMC Section 12.22-A,25, to the satisfaction of LAHD, and in consideration of the project's SB 330 Determination, dated July 1, 2022 (or any subsequent update to that letter as deemed necessary by LAHD in order to comply with SB 8). Enforcement of the terms of said covenant shall be the responsibility of LAHD. The applicant shall present a copy of the recorded covenant to the Department of City Planning for inclusion in this file. The project shall comply with the Guidelines for the Affordable Housing Incentives Program adopted by the City Planning Commission and with any monitoring requirements established by the LAHD. Refer to the Density Bonus Legislation Background section of this determination for more information.
5. **Housing Replacement.** Prior to issuance of a building permit, the owner shall execute a covenant to the satisfaction of the Los Angeles Housing Department (LAHD), and in compliance with LAHD's July 1, 2022, SB 330 Determination Letter (or any subsequent update to that letter as deemed necessary by LAHD in order to comply with SB 8). Enforcement of the terms of said covenant shall be the responsibility of LAHD. The applicant will present a copy of the recorded covenant to the Department of City Planning for inclusion in this file. The project shall comply with the Guidelines for the Affordable Housing Incentives Program adopted by the City Planning Commission and with any monitoring requirements established by the LAHD. Refer to the Density Bonus Legislation Background section of this determination for more information.

On-site Restricted Affordable Units may be used to satisfy the Housing Replacement units required pursuant to SB 8 provided such units meet the income levels, to the satisfaction of LAHD.

6. Incentives.

- a. **Floor Area.** A maximum Floor Area Ratio (FAR) of 3.5 to 1 shall be permitted in lieu of the 0.5 to 1 maximum FAR otherwise permitted by the C2-1D Zone.
- b. **Rear Yard Setback.** A maximum rear yard setback of 10 feet shall be permitted in lieu of the otherwise required 20 foot rear yard setback in the C2-1D Zone.
- c. **Side Yard Setback.** A maximum side yard setback along Vine Street of zero feet shall be permitted in lieu of the otherwise required 10 foot side yard setback in the C2-1D Zone

7. Parking.

- a. **Unbundling.** Required parking may be sold or rented separately from the units, with the exception of all Restricted Affordable Units which shall include any required parking in the base rent or sales price, as verified by LAHD.
- b. **Bicycle Parking.** Bicycle parking shall be provided consistent with LAMC Section 12.21-A,16.

8. Street Trees: Street trees shall be provided to the satisfaction of the Urban Forestry Division. Street trees may be used to satisfy on-site tree requirements pursuant to LAMC Article Section 12.21.G.3 (Chapter 1, Open Space Requirement for Six or More Residential Units). Per Exhibit A and 12.21.G.3, a total of six (6) street trees shall be provided or maintained to the satisfaction of the Urban Forestry Division.

9. Landscaping:

- a. All open areas not used for buildings, driveways, parking areas, or walkways shall be attractively landscaped and maintained in accordance with a landscape plan and an automatic irrigation plan, prepared by a licensed Landscape Architect and to the satisfaction of the Department of City Planning.
- b. **Tree Wells.**
 - i. The minimum depth of tree wells on the rooftop or any other location where planters are used shall be as follows:
 - (1) Minimum depth for trees shall be 42 inches.
 - (2) Minimum depth for shrubs shall be 30 inches.
 - (3) Minimum depth for herbaceous plantings and ground cover shall be 18 inches.
 - (4) Minimum depth for an extensive green roof shall be 3 inches.
 - ii. The minimum amount of soil volume for tree wells on the rooftop or any other location where planters are used shall be based on the size of the tree at maturity:

- (1) 600 cubic feet for a small tree (less than 25 feet tall at maturity).
- (2) 900 cubic feet for a medium tree (25-40 feet tall at maturity).
- (3) 1,200 cubic feet for a large tree (more than 40 feet tall at maturity).

- 10. Circulation.** The applicant shall submit a parking and driveway plan to the Los Angeles Department of Transportation (LADOT) for approval.
- 11. Solar.** The project shall provide for the installation of a photovoltaic system, in substantial conformance with the plans stamped "Exhibit A", and comply with the Los Angeles Municipal Green Building Code, Section 99.04.211 and 99.05.211, to the satisfaction of the Department of Building and Safety.
- 12. Electric Vehicle Parking.** All electric vehicle charging spaces (EV Spaces) and electric vehicle charging stations (EVCS) shall comply with the regulations outlined in Sections 99.04.106 and 99.05.106 of Article 9, Chapter IX of the LAMC.
- 13. Construction Generators.** The project construction contractor shall use on-site electrical sources and solar generators to power equipment rather than diesel generators, where feasible.
- 14. Materials.** A variety of high quality exterior building materials, consistent with Exhibit A, shall be used. The variety of materials used shall include at least the following: fiber cement panel, bok modern metal panel, natural stone tile, dark vinyl windows, dark bronze storefront, glass guardrails, metal guardrails, aluminum louvres, and stucco. Substitutes of an equal quality shall be permitted, to the satisfaction of the Department of City Planning.
- 15. Vehicle Access.** The project shall be limited to a maximum of two (2) driveways, with a maximum of one driveway located along Vine Street and one located along Lexington Avenue as shown in Exhibit A. The curb cut dimension shall be as narrow as permitted by LADOT.
- 16. Mechanical Equipment.** All mechanical equipment on the roof shall be screened from view by any abutting properties. The transformer, if located in the front yard or Vine Street side yard, shall be screened with landscaping and/or materials consistent with the building façade on all exposed sides (those not adjacent to a building wall).
- 17. Lighting.** Outdoor lighting shall be designed and installed with shielding, such that the light source does not illuminate adjacent residential properties or the public right-of-way, nor the above night skies.
- 18. Graffiti.** All graffiti on the site shall be removed or painted over to match the color of the surface to which it is applied within 24 hours of its occurrence.
- 19. Trash.** Trash receptacles shall be stored within a fully enclosed portion of the building at all times. Trash/recycling containers shall be locked when not in use and shall not be placed in or block access to required parking.

B. Administrative Conditions

- 21. Final Plans.** Prior to the issuance of any building permits for the project by the Department of Building and Safety, the applicant shall submit all final construction plans that are awaiting issuance of a building permit by the Department of Building and Safety for final review and approval by the Department of City Planning. All plans that are awaiting issuance of a building permit by the Department of Building and Safety shall be stamped by Department of City Planning staff "Final Plans". A copy of the Final Plans, supplied by the applicant, shall be retained in the subject case file.
- 22. Notations on Plans.** Plans submitted to the Department of Building and Safety, for the purpose of processing a building permit application shall include all of the Conditions of Approval attached herein as a cover sheet, and shall include any modifications or notations required herein.
- 23. Building Plans.** A copy of the first page of this grant and all Conditions and/or any subsequent appeal of this grant and its resultant Conditions and/or letters of clarification shall be printed on the building plans submitted to the Development Services Center and the Department of Building and Safety for purposes of having a building permit issued.
- 24. Corrective Conditions.** The authorized use shall be conducted at all times with due regard for the character of the surrounding district, and the right is reserved to the City Planning Commission, or the Director pursuant to Section 12.27.1 of the Municipal Code, to impose additional corrective conditions, if, in the Commission's or Director's opinion, such conditions are proven necessary for the protection of persons in the neighborhood or occupants of adjacent property.
- 25. Approvals, Verification and Submittals.** Copies of any approvals, guarantees or verification of consultations, reviews or approval, plans, etc., as may be required by the subject conditions, shall be provided to the Department of City Planning for placement in the subject file.
- 26. Code Compliance.** All area, height and use regulations of the zone classification of the subject property shall be complied with, except wherein these conditions explicitly allow otherwise.
- 27. Department of Building and Safety.** The granting of this determination by the Director of Planning does not in any way indicate full compliance with applicable provisions of the Los Angeles Municipal Code Chapter IX (Building Code). Any corrections and/or modifications to plans made subsequent to this determination by a Department of Building and Safety Plan Check Engineer that affect any part of the exterior design or appearance of the project as approved by the Director, and which are deemed necessary by the Department of Building and Safety for Building Code compliance, shall require a referral of the revised plans back to the Department of City Planning for additional review and sign-off prior to the issuance of any permit in connection with those plans.
- 28. Department of Water and Power.** Satisfactory arrangements shall be made with the Los Angeles Department of Water and Power (LADWP) for compliance with LADWP's Rules Governing Water and Electric Service. Any corrections and/or modifications to plans made subsequent to this determination in order to accommodate changes to the project due to the under-grounding of utility lines, that are outside of substantial compliance or that affect any part of the exterior design or appearance of the project as approved by the Director, shall require a referral of the revised plans back to the Department of City Planning for

additional review and sign-off prior to the issuance of any permit in connection with those plans.

- 29. Covenant.** Prior to the issuance of any permits relative to this matter, an agreement concerning all the information contained in these conditions shall be recorded in the County Recorder's Office. The agreement shall run with the land and shall be binding on any subsequent property owners, heirs or assign. The agreement must be submitted to the Department of City Planning for approval before being recorded. After recordation, a copy bearing the Recorder's number and date shall be provided to the Department of City Planning for attachment to the file.
- 30. Definition.** Any agencies, public officials or legislation referenced in these conditions shall mean those agencies, public offices, legislation or their successors, designees or amendment to any legislation.
- 31. Enforcement.** Compliance with these conditions and the intent of these conditions shall be to the satisfaction of the Department of City Planning and any designated agency, or the agency's successor and in accordance with any stated laws or regulations, or any amendments thereto.
- 32. Expedited Processing Section.** Prior to the clearance of any conditions, the applicant shall show proof that all fees have been paid to the Department of City Planning, Expedited Processing Section.
- 33. Indemnification and Reimbursement of Litigation Costs.**

Applicant shall do all of the following:

- a. Defend, indemnify and hold harmless the City from any and all actions against the City relating to or arising out of, in whole or in part, the City's processing and approval of this entitlement, including but not limited to, an action to attack, challenge, set aside, void, or otherwise modify or annul the approval of the entitlement, the environmental review of the entitlement, or the approval of subsequent permit decisions, or to claim personal property damage, including from inverse condemnation or any other constitutional claim.
- b. Reimburse the City for any and all costs incurred in defense of an action related to or arising out of, in whole or in part, the City's processing and approval of the entitlement, including but not limited to payment of all court costs and attorney's fees, costs of any judgments or awards against the City (including an award of attorney's fees), damages, and/or settlement costs.
- c. Submit an initial deposit for the City's litigation costs to the City within 10 days' notice of the City tendering defense to the applicant and requesting a deposit. The initial deposit shall be in an amount set by the City Attorney's Office, in its sole discretion, based on the nature and scope of action, but in no event shall the initial deposit be less than \$50,000. The City's failure to notice or collect the deposit does not relieve the applicant from responsibility to reimburse the City pursuant to the requirement in paragraph (b).
- d. Submit supplemental deposits upon notice by the City. Supplemental deposits may be required in an increased amount from the initial deposit if found necessary by the City to protect the City's interests. The City's failure to notice or collect the deposit does

not relieve the applicant from responsibility to reimburse the City pursuant to the requirement in paragraph (b).

- e. If the City determines it necessary to protect the City's interest, execute an indemnity and reimbursement agreement with the City under terms consistent with the requirements of this condition.

The City shall notify the applicant within a reasonable period of time of its receipt of any action and the City shall cooperate in the defense. If the City fails to notify the applicant of any claim, action, or proceeding in a reasonable time, or if the City fails to reasonably cooperate in the defense, the applicant shall not thereafter be responsible to defend, indemnify or hold harmless the City.

The City shall have the sole right to choose its counsel, including the City Attorney's office or outside counsel. At its sole discretion, the City may participate at its own expense in the defense of any action, but such participation shall not relieve the applicant of any obligation imposed by this condition. In the event the applicant fails to comply with this condition, in whole or in part, the City may withdraw its defense of the action, void its approval of the entitlement, or take any other action. The City retains the right to make all decisions with respect to its representations in any legal proceeding, including its inherent right to abandon or settle litigation.

For purposes of this condition, the following definitions apply:

"City" shall be defined to include the City, its agents, officers, boards, commissions, committees, employees, and volunteers.

"Action" shall be defined to include suits, proceedings (including those held under alternative dispute resolution procedures), claims, or lawsuits. Actions include actions, as defined herein, alleging failure to comply with any federal, state or local law.

Nothing in the definitions included in this paragraph are intended to limit the rights of the City or the obligations of the applicant otherwise created by this condition.

FINDINGS

Conditional Use Findings

- 1. That the project will enhance the built environment in the surrounding neighborhood or will perform a function or provide a service that is essential or beneficial to the community, city or region.**

The corner property is comprised of five parcels, measuring approximately 40,787 square feet square feet (0.9 acres) with approximately 198 feet along Vine Street, and 173 feet and six (6) inches feet along Lexington Avenue. The site is currently improved with two single-story commercial buildings and a surface parking lot. The property does not contain any existing residential housing units as confirmed by the Replacement Unit Determination issued by the Los Angeles Housing Department (LAHD) on July 1, 2022.

The Conditional Use for an additional 12.5 percent density bonus (beyond the 35 percent permitted through a by-right density bonus) approved herein results in an additional 13 housing units, for a total of 151 units. In exchange, the project will set aside at least 16 percent (17 units) of the base density for Very Low Income Households for a minimum of 55 years.

The proposed building reaches a height of 87-feet, and will have a Floor Area Ratio (FAR) of 3.5:1. The project includes 3,690 square feet of commercial ground floor uses and 87 parking spaces (80 residential parking spaces and seven commercial parking spaces) within two levels of above grade parking.

The proposed building with street activating uses and landscaping will replace two (2) vacant commercial buildings and a surface parking lot thereby providing a function that is both essential and beneficial to the Hollywood Community Plan area and the City of Los Angeles by providing 151 dwelling units including 17 Very Low Income units in a region with high demand for affordable housing and housing in general.

At the hearing officer hearing held on February 14, 2023 for the proposed project, members of the surrounding community stated that the vacant buildings had recently attracted crime activity. By redeveloping the subject site with a new mixed-use residential building with active pedestrian level uses such as retail uses and pedestrian plaza, the project will contribute to increased eyes on the street and resident activity. Therefore, the proposed project will add a function that is beneficial to the community by providing retail amenities to the surrounding community and by increasing pedestrian safety.

Therefore, the proposed 151-unit development, will provide 134 new market rate and 17 new Very Low Income affordable housing units, and thus is performing a function, the provision of adequate housing that is affordable to households of various income levels, that is essential and beneficial to the city and the region.

- 2. That the project's location, size, height, operations and other significant features will be compatible with and will not adversely affect or further degrade adjacent properties, the surrounding neighborhood or the public health, welfare, and safety.**

The proposed project consists of the construction of a new seven-story, 151 dwelling unit mixed-use residential development which includes 17 units set aside for Very Low Income households. The project site is currently developed with two vacant commercial buildings with surface parking which will be demolished as part of the proposed development.

The approval herein is for a Conditional Use to allow an additional 12.5 percent density bonus (for a total of a 47.5 percent density bonus from the base density) to allow for a total of 151 dwelling units, representing an increase of 13 units beyond what would otherwise be permitted through the by-right 35 percent density bonus. In order to obtain the additional requested 12.5 percent density bonus, the project must set aside at least 16 percent of the base density, equal to 17 units, for Very Low Income units. The project will provide 17 units for Very Low Income households in exchange for the requested Density Bonus. As such, the Density Bonus request results in 138 units and the Conditional Use request results in an additional 13 units for a total of 151 dwelling units with 17 affordable units.

The project is zoned C2-1D and proposes a maximum height of 87 feet. The Height District 1 allows unlimited height and stories in the C2 Zone. The proposed height of the project is allowed by-right and is thus in compliance with the permitted height requirements under the designated zone. Furthermore, the applicant is requesting an Off-Menu incentive, pursuant to Density Bonus law, to allow a FAR increase from 0.5:1 to 3.5:1 to allow 143,295 square feet in floor area. There are buildings near the subject site that are of similar size and scale to the proposed project.

The property is located within the Hollywood Community Plan, a densely populated portion of the City of Los Angeles. The project site is located in an urbanized area surrounded by medium residential and commercial zones that are generally developed with a combination of commercial, residential, hotel, restaurant and office uses. The subject property is not adjacent to any single-family zoned properties. Rather, it is surrounded by properties zoned for Highway Oriented Commercial uses and Medium Residential uses. Therefore, construction of the housing development with a retail component will serve to benefit the neighborhood rather than degrade it. The façades are well-articulated and feature a prominent ground design that distinguishes it from the upper levels. The residential lobby and retail component at the ground level engage pedestrians along Vine Street and Lexington Avenue. Well-designed landscaping and addition of pedestrian plaza at the ground level will create a pleasing transition from the pedestrian realm of the sidewalk to the façade of the building. Therefore, the project is compatible with the surrounding neighborhood and will not adversely affect nor degrade adjacent properties, surrounding neighborhood, or the public health, safety, or welfare.

With the exception of the requests herein, the proposed project is otherwise entirely consistent with the requirements of the underlying zone. The project's significant features, including the proposed building's use, density, height, and FAR, are permitted by the underlying zone and the provisions of Density Bonus law. The project has been thoughtfully designed to include landscaping and above ground on-site parking.

Given the proposed project's location within the Hollywood Community Plan area, along with the existing development in the immediate vicinity of the subject property and its proximity to commercial thoroughfares, the project's location, size, height, operations, and other significant features will be compatible with and will not adversely affect adjacent properties, the surrounding neighborhood, or the public health, welfare, and safety.

3. That the project substantially conforms with the purpose, intent and provisions of the General Plan, the applicable community plan, and any applicable specific plan.

The project site is located within the Hollywood Community Plan, which is one of 35 Community Plans which together form the land use element of the General Plan. The Community Plan was adopted in 1988 and designates the site for Highway Oriented Commercial land uses corresponding to the C Zone. The project site is zoned C2-1D and is

thus consistent with the existing land use designation. The subject property is not located within the boundaries of and is not subject to any specific plan or community design overlay.

The proposed project conforms to the following goals, objectives and policies of the Community Plan:

- Further the development of Hollywood as a major center of population, employment, retail services, and entertainment; and to perpetuate its image as the international center of the motion picture industry.
- Make provision for the housing required to satisfy the varying needs and desires of all economic segments of the Community, maximizing the opportunity for individual choice.

The Conditional Use approved herein is for a 47.5% Density Bonus which allows for the construction of a mixed-use residential development with 151 dwelling units, of which 17 units are restricted for families or persons of Very Low Income, and 3,690 square feet of commercial ground floor uses. The 35 percent by-right density bonus would allow for 138 units (equal to an increase of 36 units beyond the 102 base density) to be constructed on the project site therefore, the density bonus request results in 138 units and the Conditional Use request results in an additional 13 units for a total of 151 dwelling units with 17 affordable units. The project's Very Low Income and market rate units satisfy both the needs of affordable housing as well as the City's need for more housing overall. The project will result in the net addition of 17 covenanted affordable dwelling units in a community in-need of more affordable housing.

The project is further consistent with other elements of the General Plan, including the Framework Element, the Housing Element, and the Mobility Element. The Framework Element was adopted by the City of Los Angeles in December 1996 and re-adopted in August 2001. The Framework Element provides guidance regarding policy issues for the entire City of Los Angeles, including the project site. The Framework Element also sets forth a Citywide comprehensive long-range growth strategy and defines Citywide policies regarding such issues as land use, housing, urban form, neighborhood design, open space, economic development, transportation, infrastructure, and public services.

The project supports the following goal and objective of the Framework Element:

Goal 3C: Multi-family neighborhoods that enhance the quality of life for the City's existing and future residents.

Objective 3.7: Provide for the stability and enhancement of multi-family residential neighborhoods and allow for growth in areas where there is sufficient public infrastructure and services and the residents' quality of life can be maintained or improved.

The project enhances the quality of life for the City's existing residents by providing a modern and upgraded residential structure in an area that needs new housing supply. The increased density is compatible with the nearby surrounding area. The project is located on the intersection of Vine Street and Lexington Avenue, a major cross-street with multiple transit options. Residents will be able to utilize transit and are within walking distance to a church, various restaurants, retail stores, small businesses and government facilities.

The Housing Element of the General Plan (2021-2029) will be implemented by the recommended action herein. The Housing Element is the City's blueprint for meeting housing and growth challenges. It identifies the City's housing conditions and needs, reiterates goals, objectives, and policies that are the foundation of the City's housing and growth strategy, and

provides the array of programs the City has committed to implement to create sustainable, mixed-income neighborhoods across the City. The Housing Element includes the following objectives and policies relevant to the instant request:

Goal 1: A City where housing production results in an ample supply of housing to create more equitable and affordable options that meet existing and projected needs.

Objective 1.1: Forecast and plan for existing and projected housing needs over time with the intention of furthering Citywide Housing Priorities.

Policy 1.1.2: Plan for appropriate land use designations and density to accommodate an ample supply of housing units by type, cost, and size within the City to meet housing needs, according to Citywide Housing Priorities and the City's General Plan.

Policy 1.1.6: Allocate citywide housing targets across Community Plan areas in a way that seeks to address patterns of racial and economic segregation, promote jobs/ housing balance, provide ample housing opportunities, and affirmatively further fair housing

Objective 1.2: Facilitate the production of housing, especially projects that include Affordable Housing and/or meet Citywide Housing Priorities.

Policy 1.2.2: Facilitate the construction of a range of different housing types that addresses the particular needs of the city's diverse households

Objective 1.3: Promote a more equitable distribution of affordable housing opportunities throughout the city, with a focus on increasing Affordable Housing in Higher Opportunity Areas and in ways that further Citywide Housing Priorities.

Policy 1.3.1: Prioritize housing capacity, resources, policies and incentives to include Affordable Housing in residential development, particularly near transit, jobs, and in Higher Opportunity Areas.

Goal 2: A City that preserves and enhances the quality of housing and provides greater housing stability for households of all income levels.

Objective 2.3: Preserve, conserve and improve the quality of housing.

Goal 3: A City in which housing creates healthy, livable, sustainable, and resilient communities that improve the lives of all Angelenos.

Objective 3.1: Use design to create a sense of place, promote health, foster community belonging, and promote racially and socially inclusive neighborhoods.

Policy 3.1.5: Develop and implement environmentally sustainable urban design standards and pedestrian-centered improvements in development of a project and within the public and private realm such as shade trees, parkways and comfortable sidewalks.

Policy 3.1.6: Establish plans and development standards that promote positive health outcomes for the most vulnerable communities and populations.

Policy 3.1.7: Promote complete neighborhoods by planning for housing that includes open space, and other amenities.

Objective 3.2: Promote environmentally sustainable buildings and land use patterns that support a mix of uses, housing for various income levels and provide access to jobs, amenities, services and transportation options.

Policy 3.2.1: Promote the integration of housing with other compatible land uses at both the building and neighborhood level.

Policy 3.2.2: Promote new multi-family housing, particularly Affordable and mixed-income housing, in areas near transit, jobs and Higher Opportunity Areas, in order to facilitate a better jobs-housing.

With the approval of the Conditional Use for a 47.5% density bonus the project is able to provide 151 total units, including 17 units affordable for Very Low Income Households or individuals. The additional market rate and affordable units that are allowed with the approval of the Conditional Use promote the objectives of the Housing Element by adding to the City's housing stock and contributing to the need for mixed-income housing. The project site is currently developed with two vacant commercial buildings and a surface parking lot. The project will expand affordable rental housing (17 units) while utilizing the property to its full potential, resulting in a net gain of 151 units to the City's housing stock. It is within close proximity to various major employment and retail centers, along with several major transportation lines, thereby connecting residents to jobs, amenities, services, and transit.

The project's proposed 134 market-rate units and 17 Very Low Income units fulfill the Community Plan, Framework Element, and Housing Element goals and objectives of providing quality housing for all persons in the community, including those who otherwise might not be housed. The project utilizes development incentives to provide a higher number of residential units than would otherwise be permitted, thereby facilitating the creation of a higher number of affordable units and addressing the need for affordable housing in the City.

The Mobility Element of the General Plan, also known as Mobility Plan 2035, adopted in 2016, provides policies with the ultimate goal of developing a balanced transportation network for all users. The project supports the following policies of the Mobility Element:

Policy 3.3: Promote equitable land use decisions that result in fewer vehicle trips by providing greater proximity and access to jobs, destinations, and other neighborhood services.

Policy 5.2: Support ways to reduce vehicle miles traveled (VMT) per capita.

Policy 5.4: Continue to encourage the adoption of low and zero emission fuel sources, new mobility technologies, and supporting infrastructure.

Additionally, the project's location is near the heart of Hollywood at the intersection of Vine Street and Lexington Avenue, two roadways that are well-served by transit. The proposed project will be walking distance from transit, a church, various restaurants, retail stores, small businesses and government facilities. Thus, the project will contribute towards the creation of sustainable neighborhoods and a reduction in vehicle trips and VMT.

In addition, the project has been conditioned to comply with the electric vehicle requirements of state law. The project has also been conditioned to provide solar infrastructure. Together, these conditions further support applicable policies in the Health and Wellness Element, Air

Quality Element, and Mobility Element of the General Plan by reducing the level of pollution/greenhouse gas emissions, ensuring new development is compatible with alternative fuel vehicles, and encouraging the adoption of low emission fuel sources and supporting infrastructure. These conditions also support good planning practice by promoting overall sustainability and providing additional benefits and conveniences for residents, workers, and visitors.

The project contributes to and furthers several applicable goals, objectives, and policies of the plans that govern land use and development in the City. Therefore, the project substantially conforms with the purpose, intent, and provisions of the General Plan and the Hollywood Los Angeles Community Plan.

In addition to the above Conditional Use findings set forth in Section 12.24-E of the LAMC, the City Planning Commission shall find that:

4. The project is consistent with and implements the affordable housing provisions of the Housing Element of the General Plan.

The City's Housing Element for 2021-2029 was adopted by City Council on November 24, 2021. The Housing Element of the General Plan will be implemented by the recommended action herein. The Housing Element is the City's blueprint for meeting housing and growth challenges. It identifies the City's housing conditions and needs, reiterates goals, objectives, and policies that are the foundation of the City's housing and growth strategy, and provides the array of programs the City has committed to implement to create sustainable, mixed-income neighborhoods across the City.

As discussed in Finding No. 3, the project, including 134 market-rate units and 17 units reserved for Very Low Income Households, is consistent with many of the goals and objectives of the Housing Element of the General Plan.

5. The project contains the requisite number of Restricted Affordable Units, based on the number of units permitted by the maximum allowable density on the date of application, as follows:

- a. **11% Very-Low Income Units for a 35% density increase; or**
- b. **20% Low Income Units for a 35% density increase; or**
- c. **40% Moderate Income Units for a 35% density increase in for-sale projects.**

The project may then be granted additional density increases beyond 35% by providing additional affordable housing units in the following manner:

- a. **For every additional 1% set aside of Very-Low Income Units, the project is granted an additional 2.5% density increase; or**
- b. **For every additional 1% set aside of Low Income Units, the project is granted an additional 1.5% density increase; or**
- c. **For every additional 1% set aside of Moderate Income Units in for-sale projects, the project is granted an additional 1% density increase; or**
- d. **In calculating the density increase and Restricted Affordable Units, each component of any density calculation, including base density and bonus density, resulting in fractional units shall be separately rounded up to the next whole number.**

The subject property is zoned C2-1D, which limits density to one (1) dwelling unit per 400 square feet of lot area. The subject property has a total lot area of 40,786 square feet, and as

such, the permitted base density on the subject property is 102 units.² In exchange for reserving a portion of the units for affordable housing, the applicant is entitled to a maximum 35 percent density bonus by-right. The applicant is seeking an additional 12.5 percent density bonus (or a total of a 47.5 percent density bonus) through a Conditional Use to allow for the proposed 151 dwelling units to be built on the site

Pursuant to the LAMC and California Government Code Section 65915, a Housing Development Project that sets aside a certain percentage of units as affordable, either in rental or for-sale units, shall be granted a corresponding density bonus, up to a maximum of 35 percent. While these provisions are limited to 35 percent, Government Code Section 65915(f) states that “the amount of density bonus to which an applicant is entitled shall vary according to the amount by which the percentage of affordable housing units exceeds the percentage established.” As such, in instances where a project is seeking a density bonus increase that is more than 35 percent, the amount of required units that are set aside as affordable shall vary depending on the requested amount of density bonus. Therefore, it is appropriate that any project that requests a density bonus increase beyond 35 percent would extend the existing set-aside charts located in Section 12.22-A,25 of the LAMC. LAMC Section 12.24-U,26, which implements this provision of State law, states, as a Conditional Use, a project may be granted additional density increases beyond the 35 percent maximum by providing additional affordable housing units. Consistent with this Section, Table 1 below illustrates how the maximum allowable Density Bonus increases for every unit set aside for Very Low Income Households (2.5 percent density increase for every additional one [1] percent of Very Low Income units provided), based on the base density and the chart prescribed in LAMC Section 12.22-A,25.

Table 1: Density Bonus Percentages

Very Low Income Units (Percentage of Base Density)	Maximum Density Bonus Permitted (Based on Base Density)
5 %*	20 %*
6 %*	22.5 %*
7 %*	25 %*
8 %*	27.5 %*
9 %*	30 %*
10 %*	32.5 %*
11 %*	35 %*
15 %	45%
16 %	47.5 %

*Existing set-aside chart as listed in Section 12.22-A,25 of the LAMC

For the subject property, a 35 percent by-right density bonus would allow for 138 units (equal to an increase of 36 units beyond the 102 base density) to be constructed on the project site. As illustrated in Table 1 above, in order to qualify for the 35 percent by-right density bonus, the project would be required to set aside 11 percent of the base density, or 11 units, for Very Low Income Households. The applicant is seeking an additional 12.5 percent density bonus (for a total of a 47.5% density bonus from the base density) through a Conditional Use to allow for a total of 151 dwelling units, representing an increase of 13 units beyond what would otherwise be permitted through the by-right 35 percent density bonus. In order to obtain the additional requested 12.5 percent density bonus, as shown in Table 1, the project must set aside at least 16 percent of the base density, equal to 17 units, for Very Low Income units.

² Assembly Bill 2501 clarifies that density calculations that result in a fractional number are to be rounded up to the next whole number. This applies to base density, number of bonus units, and number of affordable units required to be eligible for the density bonus.

The project will provide 17 units for Very Low Income households in exchange for the requested Density Bonus. As such, the Density Bonus request results in 138 units with 11 Very Low Income units and the Conditional Use request results in an additional 13 units for a total of 151 dwelling units with 17 affordable units.

6. The project meets any applicable dwelling unit replacement requirements of the California Government Code Section 65915(c)(3).

The project includes the demolition of two (2) one-story commercial buildings and surface parking lot. Per the SB 330 Determination Letter dated July 1, 2022, there are no existing housing units present at the site and thus the project is not required to replace any units. Therefore, the project will meet the applicable dwelling unit replacement requirements of the California Government Code Section 65915(c)(3).

7. The project's Restricted Affordable Units are subject to a recorded affordability restriction of 55 years from the issuance of the Certificate of Occupancy, recorded in a covenant acceptable to the Housing Department, and subject to fees as set forth in Section 19.14 of the LAMC.

The proposed project has been conditioned to record a covenant for affordability restriction of a period of 55 years from the issuance of the Certificate of Occupancy, to the satisfaction of the Los Angeles Housing Department, and subject to fees as set forth in Section 19.14 of the LAMC.

8. The project addresses the policies and standards contained in the City Planning Commission's Affordable Housing Incentives Guidelines.

The City Planning Commission approved the Affordable Housing Incentives Guidelines (under Case No. CPC-2005-1101-CA) on June 9, 2005. The Guidelines were subsequently approved by the City Council on February 20, 2008, as a component of the City of Los Angeles Density Bonus Ordinance. The Guidelines describe the density bonus provisions and qualifying criteria, incentives available, design standards, and the procedures through which projects may apply for a density bonus and incentives. LAHD utilizes these Guidelines in the preparation of Housing Covenants for Affordable Housing Projects. The Guidelines prescribe that the design and location of affordable units be comparable to the market rate units, the equal distribution of amenities, LAHD monitoring requirements, affordability levels, and procedures for obtaining LAHD sign-offs for building permits.

The project will result in 151 new dwelling units, of which seven 17 will be reserved for Very Low Income Household occupancy and the remainder will be offered as market rate units. In order to ensure that there is equal distribution of amenities, the project has been conditioned to provide the private balconies in accordance with the requirements of the LAMC. All residents of the proposed project will have access to all common open space amenities within the building and each unit will have adequate private open space. The restricted units will comply with affordability requirements in the Guidelines set forth by LAHD in conformance with US Department of Housing and Urban Development (HUD). Additionally, as part of the building permit process, the applicant will execute a covenant to the satisfaction of LAHD who will ensure compliance with the Guidelines. Therefore, the project will address the policies and standards contained in the Guidelines.

Density Bonus/Affordable Housing Incentives Compliance Findings

9. Pursuant to Section 12.22 A.25(g)(2)(i)(c) of the LAMC and Section 65915(e) of the California Government Code, the decision-maker **shall approve** a density bonus and requested incentive(s) unless the Commission finds that:
- a. ***The Incentives do not result in identifiable and actual cost to provide for affordable housing costs as defined in California Health and Safety Code Section 50052.5 or Section 50053 for rents for the affordable units.***

The record does not contain substantial evidence that would allow the City Planning Commission to make a finding that the requested incentives do not result in identifiable and actual cost to provide for affordable housing costs per State Law. The California Health and Safety Code Sections 50052.5 and 50053 define formulas for calculating affordable housing costs for Very Low, Low, and Moderate Income Households. Section 50052.5 addresses owner-occupied housing and Section 50053 addresses rental Households. Affordable housing costs are a calculation of residential rent or ownership pricing not to exceed 25 percent gross income based on area median income thresholds depending on affordability levels.

Based on the set-aside of 16 percent of the base density for Very Low Income Households, the applicant is entitled to three (3) incentives under both Government Code Section 65915 and the LAMC. The request for FAR increase, reduction in rear yard setback and reduction in side yard setback are requested as Incentives.

Floor Area Ratio

Height District 1 in commercial zones has no limit on height or stories. Projects subject to Commercial Corner development standards are limited to 45 feet in height, however mixed-use projects are exempt from Commercial Corner standards and are allowed unlimited height and stories. Height District 1 allows for a maximum base FAR of 1.5:1. However, the "D" Limitation on the Property restricts the site to an FAR to 0.5:1 which is equal to a maximum of 20,393 square feet of total building area. The applicant is requesting an off-menu incentive for a maximum FAR of 3.5:1 to 1 to allow 143,295 square feet of floor area.

The requested increase in FAR will allow for the construction of affordable units in addition to larger-sized dwelling units and retail space at the ground level. Granting of the incentive would result in a building design and construction efficiencies that provide for affordable housing costs; it enables the developer to expand the building envelope so that additional affordable units can be constructed and the overall space dedicated to residential uses is increased. The increased building envelope also ensures that all dwelling units are of a habitable size while providing a variety of unit types. This Incentives supports the applicant's decision to set aside a minimum of 17 dwelling units for Very Low Income Households for 55 years.

Rear Yard Setback

The subject property is zoned C2-1D, which requires a 20 foot rear yard along the northerly property line. Per LAMC Section 12.22-A,25, the applicant is requesting an Off-Menu incentive to permit a 10 foot rear yard setback in lieu of the otherwise required 20 foot rear yard setback. The proposed seven-story residential building has a 10 foot proposed rear yard setback. The project has requested to reduce the rear yard by 50 percent to allow for a 10-foot rear yard setback. This additional 10 feet of building depth

allows the project to accommodate the requested density of 151 units (with 17 units set aside for Very Low Income) and the requested floor area.

The requested reduction in rear yard setback will allow for the construction of affordable units in addition to larger-sized dwelling units and retail space at the ground level. Granting of the incentive would result in a building design and construction efficiencies that provide for affordable housing costs; it enables the developer to expand the building envelope so that additional affordable units can be constructed and the overall space dedicated to residential uses is increased. The increased building envelope also ensures that all dwelling units are of a habitable size while providing a variety of unit types. The reduced yard creates a larger floor plate that allows more habitable floor area and more units to be built on each floor, thus avoiding a taller development that is more expensive to build. This construction cost savings is then passed on to each of the units in the project, including the affordable units. This Incentives supports the applicant's decision to set aside a minimum of 17 dwelling units for Very Low Income Households for 55 years.

Side Yard Setback (Westerly)

The subject property is zoned C2-1D, which requires a 10 foot side yard along Vine Street. Per LAMC Section 12.22-A,25, the applicant is requesting an Off-Menu incentive to permit zero (0) side yard setback in lieu of the otherwise required 10 foot side yard setback. The proposed seven-story residential building has no side yard setback along Vine Street. This additional 10 feet of building depth allows the project to accommodate the requested density of 151 units (with 17 units set aside for Very Low Income) and the requested floor area.

The requested reduction in side yard setback will allow for the construction of affordable units in addition to larger-sized dwelling units and retail space at the ground level. Granting of the incentive would result in a building design and construction efficiencies that provide for affordable housing costs; it enables the developer to expand the building envelope so that additional affordable units can be constructed and the overall space dedicated to residential uses is increased. The increased building envelope also ensures that all dwelling units are of a habitable size while providing a variety of unit types. The reduced yard creates a larger floor plate that allows more habitable floor area and more units to be built on each floor, thus avoiding a taller development that is more expensive to build. This construction cost savings is then passed on to each of the units in the project, including the affordable units. This Incentives supports the applicant's decision to set aside a minimum of 17 dwelling units for Very Low Income Households for 55 years.

- b. *The Incentive will have a Specific Adverse Impact upon public health and safety or the physical environment or any real property that is listed in the California Register of Historical Resources and for which there is no feasible method to satisfactorily mitigate or avoid the Specific Adverse Impact without rendering the development unaffordable to Very Low, Low and Moderate Income Households. Inconsistency with the zoning ordinance or general plan land use designation shall not constitute a specific, adverse impact upon the public health or safety.***

There is no evidence that the proposed density bonus incentives will have a specific adverse impact upon public health and safety or the physical environment, or any real property that is listed in the California Register of Historical Resources. A "specific adverse impact" is defined as "a significant, quantifiable, direct and unavoidable impact, based on objective, identified written public health or safety standards, policies, or

conditions as they existed on the date the application was deemed complete" (LAMC Section 12.22-A,25(b)).

The project does not involve a contributing structure in a designated Historic Preservation Overlay Zone or on the City of Los Angeles list of Historical-Cultural Monuments. The project is not located on a substandard street in a Hillside area or a Very High Fire Hazard Severity Zone. There is no evidence in the record which identifies a written objective health and safety standard that has been exceeded or violated. Based on the above, there is no basis to deny the requested incentives. Therefore, there is no substantial evidence that the project's proposed incentives will have a specific adverse impact on the physical environment, on public health and safety, or on property listed in the California Register of Historic Resources.

c. The incentives are contrary to state or federal law.

There is no evidence in the record that any of the incentives are contrary to state or federal law.

Site Plan Review Findings

10. That the project is in substantial conformance with the purposes, intent and provisions of the General Plan, applicable community plan, and any applicable specific plan.

The Los Angeles General Plan sets forth goals, objectives, and policies that guide both Citywide and community specific land use policies. The General Plan is comprised of a range of State-mandated elements, including, but not limited to, Land Use, Housing, Transportation/Mobility, Noise, and Safety. Each of these Elements establishes policies that provide for the regulatory environment in managing the City and for addressing environmental concerns and problems. The majority of the policies derived from these Elements are in the form of Code Requirements of the Los Angeles Municipal Code. The City's Land Use Element is divided into 35 community plans that establish parameters for land use decisions within those sub-areas of the City. While the General Plan sets out a long-range vision and guide to future development, the 35 Community Plans provide the specific, neighborhood-level detail, relevant policies, and implementation strategies necessary to achieve the General Plan objectives. The project site is located in the Hollywood Community Plan area and is not subjected to any applicable specific plans.

Hollywood Community Plan

The project site is located within the Hollywood Community Plan (adopted in 1988), which is one of 35 Community Plans which together form the land use element of the General Plan. The Community Plan designates the site for Highway Oriented Commercial land uses with corresponding zones of C1, C2, P, RAS3 and RAS4. The project site is zoned C2-1D and is thus consistent with the existing land use designation, as shown in the following zoning map of the property.

The proposed project is consistent with the following goals, objectives and policies of the Community Plan:

- Further the development of Hollywood as a major center of population, employment, retail services, and entertainment; and to perpetuate its image as the international center of the motion picture industry.
- Make provision for the housing required to satisfy the varying needs and desires of all economic segments of the Community, maximizing the opportunity for individual choice.

The proposed project protects the surrounding residential neighborhoods from encroachment by higher density residential uses by allowing for the development of a 151-unit (including 17 units reserved for Very Low Income Households), mixed-use residential building within a commercially zoned property near the center of Hollywood. The project increases the housing stock and satisfies the needs and desires of all economic segments of the community by maximizing the opportunity for individual housing choice with the provision of affordable units.

The **Framework Element** for the General Plan (Framework Element) was adopted by the City of Los Angeles in December 1996 and re-adopted in August 2001. The Framework Element provides guidance regarding policy issues for the entire City of Los Angeles, including the project site. The Framework Element also sets forth a Citywide comprehensive long-range growth strategy and defines Citywide policies regarding such issues as land use, housing, urban form, neighborhood design, open space, economic development, transportation, infrastructure, and public services. The Framework Element includes the following goals, objectives and policies relevant to the instant request:

Goal 3A: A physically balanced distribution of land uses that contributes towards and facilitates the City's long-term fiscal and economic viability, revitalization of economically depressed areas, conservation of existing residential neighborhoods, equitable distribution of public resources, conservation of natural resources, provision of adequate infrastructure and public services, reduction of traffic congestion and improvement of air quality, enhancement of recreation and open space opportunities, assurance of environmental justice and a healthful living environment, and achievement of the vision for a more liveable city.

Objective 3.1: Accommodate a diversity of uses that support the needs of the City's existing and future residents, businesses, and visitors.

Policy 3.1.4: Accommodate new development in accordance with land use and density provisions of the General Plan Framework Long-Range Land Use Diagram.

Objective 3.2: Provide for the spatial distribution of development that promotes an improved quality of life by facilitating a reduction of vehicular trips, vehicle miles traveled, and air pollution.

Policy 3.2.1: Provide a pattern of development consisting of distinct districts, centers, boulevards, and neighborhoods that are differentiated by their functional role, scale, and character. This shall be accomplished by considering factors such as the existing concentrations of use, community-oriented activity centers that currently or potentially service adjacent neighborhoods, and existing or potential public transit corridors and stations.

Policy 3.2.2: Establish, through the Framework Long-Range Land Use Diagram, community plans, and other implementing tools, patterns and types of development that improve the integration of housing with commercial uses and the integration of public services and various densities of residential development within neighborhoods at appropriate locations.

Objective 3.4: Encourage new multi-family residential, retail commercial, and office development in the City's neighborhood districts, community, regional, and downtown centers as well as along primary transit corridors/boulevards, while at the same time conserving existing neighborhoods and related districts.

Policy 3.4.1: Conserve existing stable residential neighborhoods and lower - intensity commercial districts and encourage the majority of new commercial and mixed-use (integrated commercial and residential) development to be located (a) in a network of neighborhood districts, community, regional, and downtown centers, (b) in proximity to rail and bus transit stations and corridors, and (c) along the City's major boulevards, referred to as districts, centers, and mixed-use boulevards, in accordance with the Framework Long-Range Land Use Diagram.

The proposed project will result in the development of a mixed-use residential building that will provide 151 dwelling units, including 17 units reserved for Very Low Income Households, thereby contributing toward and facilitating the City's long-term housing demands and vision for a more liveable city.

The project site is located within 1,250 feet from the intersection of Gower Street & Santa Monica Boulevard which qualifies as a Major Transit Stop and is served by numerous bus lines, primarily along Vine Street that are operated by the Los Angeles Metropolitan Transportation Authority (Metro) including Metro Lines 210 (Vine/Lexington) and 4 (Santa Monica/Vine). The numerous transit options in the area will allow future residents to reduce their single-occupancy vehicular trips.

The project site is currently occupied by vacant commercial uses and a surface parking lot. The development of the site will enable the City to conserve nearby existing stable residential neighborhoods and lower-intensity commercial districts by allowing controlled growth away from such neighborhoods and districts. Therefore, the proposed 151-unit residential building is consistent with the Distribution of Land Use goals, objectives and policies of the General Plan Framework Element.

The proposed mixed-use residential development increases the current housing stock with a residential building that will provide 151 units as well as ground floor commercial uses that will help supply the diverse economic and physical needs of residents in the Hollywood Community Plan area. The project will also enhance the appearance of the surrounding neighborhood as it implements good urban design practices and aligns with the Citywide Design Guidelines such as landscaping that is visible from the street, commercial ground floor uses and street trees. The project's architecture will enhance the visual appearance of the community and it has been designed and conditioned to enhance the public realm with conditions regulating landscaping and street trees and provide a safe environment for pedestrians by limiting the project to two (2) driveways. The driveway along Vine Street will have a width of 26 feet and five (5) inches and the driveway along Lexington Avenue will have a width of 32 feet. Therefore, the project is consistent with the Hollywood Community Plan.

The **Housing Element** of the General Plan (2021-2019) is the City's blueprint for meeting housing and growth challenges. It identifies the City's housing conditions and needs, reiterates goals, objectives, and policies that are the foundation of the City's housing and growth strategy, and provides the array of programs the City has committed to implement to create sustainable, mixed-income neighborhoods across the City. The Housing Element includes the following objectives and policies relevant to the instant request:

Goal 1: A City where housing production results in an ample supply of housing to create more equitable and affordable options that meet existing and projected needs.

Objective 1.1: Forecast and plan for existing and projected housing needs over time with the intention of furthering Citywide Housing Priorities.

Policy 1.1.2: Plan for appropriate land use designations and density to accommodate an ample supply of housing units by type, cost, and size within the City to meet housing needs, according to Citywide Housing Priorities and the City's General Plan.

Policy 1.1.6: Allocate citywide housing targets across Community Plan areas in a way that seeks to address patterns of racial and economic segregation, promote jobs/ housing balance, provide ample housing opportunities, and affirmatively further fair housing

Objective 1.2: Facilitate the production of housing, especially projects that include Affordable Housing and/or meet Citywide Housing Priorities.

Policy 1.2.2: Facilitate the construction of a range of different housing types that addresses the particular needs of the city's diverse households

Objective 1.3: Promote a more equitable distribution of affordable housing opportunities throughout the city, with a focus on increasing Affordable Housing in Higher Opportunity Areas and in ways that further Citywide Housing Priorities.

Policy 1.3.1: Prioritize housing capacity, resources, policies and incentives to include Affordable Housing in residential development, particularly near transit, jobs, and in Higher Opportunity Areas.

Goal 2: A City that preserves and enhances the quality of housing and provides greater housing stability for households of all income levels.

Objective 2.3: Preserve, conserve and improve the quality of housing.

Goal 3: A City in which housing creates healthy, livable, sustainable, and resilient communities that improve the lives of all Angelenos.

Objective 3.1: Use design to create a sense of place, promote health, foster community belonging, and promote racially and socially inclusive neighborhoods.

Policy 3.1.5: Develop and implement environmentally sustainable urban design standards and pedestrian-centered improvements in development of a project and within the public and private realm such as shade trees, parkways and comfortable sidewalks.

Policy 3.1.6: Establish plans and development standards that promote positive health outcomes for the most vulnerable communities and populations.

Policy 3.1.7: Promote complete neighborhoods by planning for housing that includes open space, and other amenities.

Objective 3.2: Promote environmentally sustainable buildings and land use patterns that support a mix of uses, housing for various income levels and provide access to jobs, amenities, services and transportation options.

Policy 3.2.1: Promote the integration of housing with other compatible land uses at both the building and neighborhood level.

Policy 3.2.2: Promote new multi-family housing, particularly Affordable and mixed-income housing, in areas near transit, jobs and Higher Opportunity Areas, in order to facilitate a better jobs-housing

The proposed project implements the Housing Element by increasing the housing supply consistent with the Community Commercial land use designation. The subject site consists of vacant commercial uses and surface parking lot. The approval of the request permits 151 units with 17 units set aside for Very Low Income Households. As such, the project would achieve the production of new housing opportunities, meeting the needs of the city, while ensuring a range of different housing types (studio, one- and two-bedroom rental units) that address the needs of the city's households. Therefore, the project is consistent with the Housing Element goals, objectives and policies of the General Plan.

The **Mobility Element** of the General Plan (Mobility Plan 2035) will not be affected by the recommended action herein. Vine Street, adjoining the Property to the west, is a designated Avenue II, dedicated to approximately 92.5 feet in width at this location with a 50-foot half roadway. Vine Street is required to have a 86-foot total public right-of-way dedication, or a 43-foot half roadway. Lexington Street, adjoining the Property to the south, is a designated Local Street - Standard, dedicated to approximately 60 feet in width at this location. Lexington Street is required to have a 60-foot total public right-of-way dedication, or a 30-foot half roadway.

The project as designed will support the development of these Networks and meets the following policy objectives of Mobility Plan 2035:

Policy 2.3: Recognize walking as a component of every trip and ensure high-quality pedestrian access in all site planning and public right-of-way modifications to provide a safe and comfortable walking environment.

Vehicular access to the site is provided by two ingress/egress driveways located along Vine Street and Lexington Avenue with access to the two parking levels (at grade and above grade). Pedestrian access to the building is also provided from Vine Street and Lexington Avenue.

Policy 3.1: Recognize all modes of travel, including pedestrian, bicycle, transit, and vehicular modes - including goods movement - as integral components of the City's transportation system.

Policy 3.3: Promote equitable land use decisions that result in fewer vehicle trips by providing greater proximity and access to jobs, destinations, and other neighborhood services.

Policy 3.7: Improve transit access and service to major regional destinations, job centers, and inter-modal facilities.

Policy 3.8: Provide bicyclists with convenient, secure and well-maintained bicycle parking facilities.

The project site is located within 0.25 miles of a Major Transit Stop, which is defined in Section 21064.3 of the Public Resources Code (PRC) as an existing, under construction, or planned rail station or intersection of two or more bus routes with service intervals of 15 minutes or less during the morning and afternoon commuter peak periods. Therefore, the subject site is located within a Transit Priority Area (TPA), which is defined in Section 21099(a) of the PRC as an area within 0.50 miles of a major transit stop that is existing or planned. The subject site is located within 1,250 feet from the intersection of Gower Street & Santa Monica Boulevard

which qualifies as a Major Transit Stop. Additionally, the Project Site is served by numerous bus lines, primarily along Vine Street that are operated by the Los Angeles County Metropolitan Transportation Authority (Metro) and the LADOT Downtown Area Short Hop (DASH). The proposed project is located within close proximity to public transit which will reduce vehicular trips to and from the project, vehicle miles traveled, and will contribute to the improvement of the air quality.

In addition, the project will provide a total of 80 parking spaces in two (2) levels of above grade parking. The project will also provide bicycle parking including 103 long term and 12 short term for a total of 115 bicycle parking spaces.

Policy 5.4 Continue to encourage the adoption of low and zero emission fuel sources, new mobility technologies, and supporting infrastructure.

As conditioned, all electric vehicle charging spaces (EV Spaces) and electric vehicle charging stations (EVCS) shall comply with the regulations outlined in Section 99.04.106 of Article 9, Chapter IX of the LAMC to immediately accommodate electric vehicles within the parking areas.

Therefore, the project is consistent with Mobility Plan 2035 goals, objectives and policies of the General Plan.

The **Air Quality Element** of the General Plan will be implemented by the recommended action herein. The Air Quality Element sets forth the goals, objectives and policies which will guide the City in the implementation of its air quality improvement programs and strategies. The Air Quality Element recognizes that air quality strategies must be integrated into land use decisions and represent the City's effort to achieve consistency with regional Air Quality, Growth Management, Mobility and Congestion Management Plans. The Air Quality Element includes the following Goal and Objective relevant to the instant request:

Goal 5 Energy efficiency through land use and transportation planning, the use of renewable resources and less polluting fuels, and the implementation of conservation measures including passive methods such as site orientation and tree planting.

Objective 5.1 It is the objective of the City of Los Angeles to increase energy efficiency of City facilities and private developments.

As conditioned, the project shall provide a solar-ready roof in compliance with the Los Angeles Municipal Green Building Code, Section 99.04.211.1. Therefore, the project is in conformance with the goals and policies of the Air Quality Element.

Therefore, the project is in substantial conformance with the purposes, intent and provisions of the General Plan and does not conflict with any applicable regulations or standards.

11. The project consists of an arrangement of buildings and structures (including height, bulk and setbacks), off-street parking facilities, loading areas, lighting, landscaping, trash collection, and other such pertinent improvements that is or will be compatible with existing and future development on adjacent properties and neighboring properties.

The Property is comprised of five parcels, measuring approximately 40,787 square feet. The property site is located in an urbanized neighborhood bound by Vine Street to the west and Lexington Avenue to the south. The Property fronts approximately 198 feet along Vine Street,

and 173 feet and six (6) inches feet along Lexington Avenue. The site is currently improved with two commercial buildings and a surface parking lot.

The subject property is zoned C2-1D within the Hollywood Community Plan with a Highway Oriented Commercial land use designation. The surrounding area consists of multi-story medium residential housing developments and commercial uses. Properties to the north, abutting the subject property, are zoned C2-1D with a land use designation of Highway Oriented Commercial and developed with a two-story medical facility (Hollywood Mental Health Center). Properties to the east, abutting the subject property, are zoned RD1-5-1XL with a land use designation of Low Medium II Residential and developed with two and three-story medium residential buildings. Properties to the south, across Lexington Avenue, are zoned C2-1D and RD1-5-1XL with land use designations Highway Oriented Commercial and Low Medium II Residential and developed with a fast food restaurant and two-story apartment building. Properties to the west, across Vine Street, are zoned C2-1D with a land use designation of Highway Oriented Commercial and developed with a church (St. John Armenian Church) as well as a vacant dirt lot located at the northwest corner of Lexington Avenue and Vine Street.

The proposed project includes the demolition of existing structures for the construction of a new seven-story mixed-use residential building containing 151 dwelling units with 17 units set aside for Very Low Income Households. The building will reach a height of 87 feet and have a Floor Area Ratio (FAR) of 3.5:1 with a total of 143,295 square feet of floor area. The project includes 3,690 square feet of commercial ground floor uses and 87 parking spaces (80 residential parking spaces and seven commercial parking spaces) within two (2) levels of parking (one ground level and one above grade). The project will also provide bicycle parking including 103 long term and 12 short term for a total of 115 bicycle parking spaces.

The Project's unit mix includes 16 studios, 95 one-bedroom units, and 40 two-bedroom units. Floors two through seven each propose a combination of studio, one-bedroom, and two-bedroom units oriented around a central open to the air courtyard.

Vehicular access to the site is provided by two (2) ingress/egress driveways with one located along Vine Street and one on Lexington Avenue. Pedestrian access to the building is also located off of Vine Street and Lexington Avenue. There are two (2) separate residential lobbies with access from the street located along Vine Street and Lexington Avenue. Access to the commercial uses is provided via storefront entrances facing the street.

Height

The project is zoned C2-1D. The Height District 1 allows unlimited height and stories in the C2 Zone. The proposed height of 87 feet is allowed by-right and is in compliance with the permitted height requirements under the designated zone. The building height is compatible with the existing development in the immediate surrounding area and the zoning for the surrounding area. Therefore, in conjunction with the density bonus, conditional use, and site plan review requests, and consideration of other development in the area, the project is consistent with the surrounding area.

Bulk

The subject property is zoned C2-1D. Height District 1 in commercial zones has a maximum base Floor Area Ratio (FAR) of 1.5:1. However, the "D" Limitation on the Property restricts the FAR to 0.5:1. Pursuant to Density Bonus provisions of LAMC Section 12.22-A,25 the applicant is requesting an Off-Menu incentive to allow a FAR increase from 0.5:1 to 3.5:1 to allow 143,295 square feet in floor area. As such, the project complies with the required FAR.

The bulk of the subject project is consistent with the existing development in the immediate surrounding area and with the underlying C2-1D Zone. Therefore, in conjunction with the density bonus, conditional use, and site plan review requests, and consideration of other development in the area, the project is consistent with the surrounding area.

Setbacks

The subject property is zoned C2-1D, which requires a 20 foot rear yard. Pursuant to the Density Bonus provisions of LAMC Section 12.22-A,25, the applicant is requesting an Off-Menu incentive to permit a 10 foot northerly rear yard setback in lieu of the otherwise required 20 foot rear yard setback.

Additionally, the C2-1D zone requires the project to have a 10 foot side yard. Per LAMC Section 12.22-A,25(f), the applicant has requested a second Off-Menu incentive to allow a reduction in side yard setbacks along Vine Street to allow zero feet in lieu of the otherwise required 10 feet side yard setback.

The project has been granted a reduction in the required rear and side yard setbacks as permitted through the Density Bonus Off-Menu incentives and LAMC. As such, the project complies with the required setbacks.

Furthermore, the project will comply with the setback requirements for the easterly side yard which requires a 10 foot setback and the front yard setback on Lexington Avenue which requires a zero yard setback. As such, the project is in compliance with the C2-1D Zone.

The setbacks of the subject project are consistent with the existing development in the immediate surrounding area and with the underlying C2-1D Zone. Therefore, in conjunction with the density bonus, conditional use, and site plan review requests, and consideration of other development in the area, the project is consistent with the surrounding area.

Parking

As an Eligible Housing Development, the project is eligible for Assembly Bill 2345 to allow parking at a ratio of 0.5 parking spaces per residential unit. Pursuant to AB 2345, the project is required to provide 76 parking spaces for the proposed 151 residential units. The project provides 80 residential parking spaces and thus complies with the required parking provision. The project is also providing all required commercial parking spaces (seven commercial parking spaces) and all required bicycle parking (103 long term and 12 short term).

Parking is provided within two levels of above grade parking. Vehicular access is provided by two (2) driveways, one (1) driveway is located along Vine Street and the second driveway is located along Lexington Avenue. Both driveways are located at the far end of both Vine Street and Lexington Avenue, and therefore they are not interrupting the commercial uses, lobby amenities, and pedestrian plaza along the facade of the project. Therefore, the parking will be compatible with the existing and future developments in the area.

Lighting

Lighting is required to be provided per LAMC requirements. The project proposes security lighting will be provided to illuminate the building, entrances, walkways and parking areas. As conditioned, the project is required to provide outdoor lighting with shielding, so that the light source cannot be seen from adjacent residential properties. Therefore, the lighting will be compatible with the existing and future developments in the neighborhood.

On-Site Landscaping

The project consists of 151 total dwelling units including six 16 studio, 95 one-bedroom, and 40 two-bedroom units. Floors two through seven are oriented around a central open to the air courtyard.

The project provides a total of 19,065 square feet of open space, including indoor and outdoor amenities for residents of which 5,961 square feet of space will be landscaped, which exceeds the minimum required 2,248 square feet of landscaping for the outdoor common open space areas. A total of 38 new on-site trees to be accommodated throughout the project, meeting the LAMC requirement of one tree per 4 dwelling units.

The project has been conditioned so that all open areas not used for buildings, driveways, parking areas, recreational facilities or walks will be attractively landscaped and maintained in accordance with a landscape plan, including an automatic irrigation plan, prepared by a licensed landscape architect. The planting of any required trees and street trees will be selected and installed per the Bureau of Street Services, Urban Forestry Divisions' requirements. Therefore, the on-site landscaping will be compatible with the existing and future developments in the neighborhood.

Loading/Trash Area

The development is not required to provide a loading area pursuant to LAMC Section 12.21-C.6. Nonetheless, the project will provide a loading parking space and drop off zone within the at grade parking level. Tenants moving in or out of the building will be able to park moving trucks in the loading zone located at the ground floor parking level.

The project will include on-site trash collection for both refuse and recyclable materials, in conformance with the LAMC. Compliance with these regulations will allow the project to be compatible with existing and future development. Additionally, the service area for trash collection is to be located in the parking garage at the ground level. Therefore, as proposed and conditioned, the project is compatible with existing and future development on neighboring properties.

As described above and as depicted within the plans and elevations submitted with the instant application, the project is a seven-story mixed-use residential development, with parking on-site for residents and commercial parking spaces, lighting, landscaping, trash collection, and other pertinent improvements, that is compatible with existing and future development in the surrounding area.

12. Any residential project provides recreational and service amenities to improve habitability for its residents and minimize impacts on neighboring properties.

The project consists of 151 total dwelling units including 16 studio, 95 one-bedroom, and 40 two-bedroom units, therefore pursuant to LAMC the project is required to provide 16,100 square feet of open space and exceeds this requirement by providing 19,065 square feet of open space. The project provides a 1,200 square foot publicly accessible pedestrian plaza along Lexington Avenue. Open space accessible to residents includes a 5,970 square foot courtyard on the third floor, as well as two open-air roof decks on the seventh floor containing 1,200 square feet and 620 square feet. The project also includes 6,050 square feet of private deck space and 4,025 square feet of indoor amenity space.

The project's floor area will include 3,660 square feet of lobby and leasing space, a 1,220 square foot fitness room, a 1,100 square foot club room, 5,970 square feet of podium open courtyard, 1,200 square feet of roof deck space and 4,015 square feet of other amenities.

The project will also provide a 1,200 square foot publicly accessible pedestrian plaza along Lexington Avenue to complement the commercial uses at the ground level and integrate the project at the street level.

As such, the project provides recreational and service amenities to improve habitability for its residents and minimize impacts on neighboring properties.

Environmental Findings

- 13. Class 32 CEQA Exemption.** The proposed project qualifies for a Class 32 Categorical Exemption because it conforms to the definition of "In-fill Projects". The project can be characterized as in-fill development within urban areas for the purpose of qualifying for Class 32 Categorical Exemption as a result of meeting five established conditions and if it is not subject to an Exception that would disqualify it. The Categorical Exception document dated November 30, 2021 and attached to the subject case file provides the full analysis and justification for project conformance with the definition of a Class 32 Categorical Exemption.
- 14. Flood Insurance.** The National Flood Insurance Program rate maps, which are a part of the Flood Hazard Management Specific Plan adopted by the City Council by Ordinance No. 172,081, have been reviewed and it has been determined that this project is located outside of a flood zone.

PUBLIC HEARING AND COMMUNICATIONS

Public Hearing

A public hearing for Case No. CPC-2022-7074-CU-DB-SPR-HCA was held by the Hearing Officer via teleconference on February 7, 2023, at approximately 1:00 p.m.

1. Attendees

The hearing was attended by approximately 10 people, including representatives of the applicant, local residents, and a representative from the Supporter Alliance for Environmental Protection Responsibility (SAFER).

2. Testimony

The public testimony given for the project was focused predominantly on two topics: members of the public were concerned with the current site conditions and the groups Supporters Alliance for Environmental Responsibility (SAFER) and the Carpenters Association stated environmental concerns regarding the CEQA analysis. Members of the public commented that the Neighborhood Council's support of the project was not unanimous. A member of the public requested a condition to require the applicant to keep the street clean or some type of active management. Another member of the public was concerned for the current state of the site and described that there is an "active encampment." The SAFER representative commented that the project does not meet CEQA requirements, specifically air quality requirements and materials that cause cancer. The SAFER representative requested that the hearing officer recommend denial of the project. Lastly, a member of the local community and Carpenters' Association expressed that they would be impacted by the project and that the project should hire the carpenters that work in the area to help reduce air pollution.

Following public testimony, the applicant's team responded to comments. The applicant's team confirmed that a robust CEQA analysis was conducted for the proposed project and that the project meets CEQA Guidelines. The applicant's representative Dana Sayles made herself available to neighboring residents who were concerned about the timing of construction. Ms. Sayles also explained that she was working with LAPD on the present encampment issue. Matthew Stroy from the applicant's team commented that the project was working with non-profit organizations that were interested in utilizing the vacant site in order to activate it.

The hearing officer concluded the hearing with planning staff Urban Design Studio comments as mentioned in the Professional Volunteer Program section in the report above and also informed the public of the May 11, 2023 City Planning Commission meeting date for the subject proposed project. The hearing officer also informed the public on how to become an interested party.

Written Testimony

Planning staff received written testimony from the Supporters Alliance for Environmental Responsibility SAFER and the Southwest Carpenters SWMSRCC (included in the staff report as Exhibit E), as well as a response letter from the applicant's CEQA consultant (Exhibit F).

Exhibit A – Plans

1200 VINE ST.



ARCHITECTURE

A0-0	TITLE SHEET
A0-1	VICINITY MAP
A0-2	EXISTING CONTEXT
A0-3	PROJECT DATA
A0-4	SITE SURVEY
A1-0	SITE PLAN
A1-2	OPEN SPACE EXHIBIT
A1-3	FAR CALCULATION
A1-4	CBC AREA CALCULATION
A1-5	SCHOOL FEE AREA CALC.
A2-0	BUILDING ELEVATIONS
A3-0	BUILDING PLANS
A4-0	BUILDING SECTIONS
A5-0	UNIT PLANS
A6-0	CONCEPTUAL PERSPECTIVES
A9-0	BICYCLE PARKING SPECS

LANDSCAPE

L0-1	LANDSCAPE DATA
L1-1	LANDSCAPE PLAN - L1
L1-2	LANDSCAPE PLAN - L3
L1-3	LANDSCAPE PLAN - L7
L2-1	HARDSCAPE + PLANT PALETTE

PROJECT NARRATIVE

1200 VINE IS A MIXED-USE PROJECT, APPLYING FOR AB2345 DENSITY BONUS, PROVIDING 134 MARKET-RATE UNITS, 17 AFFORDABLE UNITS, AND APPROX. 3,700 SQFT OF COMMERCIAL SPACE. THE PROJECT ALSO INCLUDES 87 TOTAL PARKING SPACES, OVER 19,000 SF OF COMMON & PRIVATE OPEN SPACE, AND A PLETHORA OF COMMON RESIDENT AMENITY SPACES SUCH AS A CLUB LOUNGE, FITNESS, CO-WORKING, & 2 ROOF DECKS. THE PROJECT IS A 7-STORY BUILDING WITH 5 LEVELS OF TYPE IIIA CONSTRUCTION OVER 2 LEVELS OF TYPE I PODIUM.

APPLICANT:

GRUBB PROPERTIES
CONTACT: MEGAN WATSON
LOS ANGELES, CA
T: 405.973.5229
MWATSON@GRUBBPROPERTIES.COM

ARCHITECT:

KTGY ARCHITECTURE + PLANNING
CONTACT: MICHAEL MILITELLO
433 S. SPRING ST.
SUITE 100
LOS ANGELES, CA 90066
T: 310.439.3928
MMILITELLO@KTGY.COM

LANDSCAPE ARCHITECT:

BORDER
CONTACT: DUANE BORDER
724 SOUTH SPRING STREET
SUITE 701
LOS ANGELES, CA 90014
T: 310.701.8460
DUANE@BORDER-LA.COM

ENTITLEMENT CONSULTANT:

THREE6IXTY
CONTACT: DANA A. SAYLES
11287 W. WASHINGTON BLVD
CULVER CITY, CA 90230
T: 310.204.3500
DANA@THREE6IXTY.NET

INTERIOR DESIGNER:

505DESIGN
CONTACT: BRIAN LUNGH
1360 WALNUT STREET
SUITE 102
BOULDER, CO 80302
T: 720.565.0505
BLUNGH@505DESIGN.COM



Architecture + Planning
888.456.5849
ktgy.com

Grubb Properties
4601 Park Road, Suite 450
Charlotte, NC 28209

1200 VINE STREET
LOS ANGELES, CA # 2021-1034

CONCEPTUAL DESIGN
APRIL 11, 2023

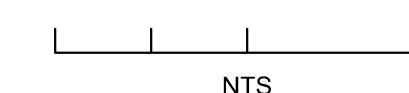

TITLE SHEET
TABLE OF CONTENTS

A0-0

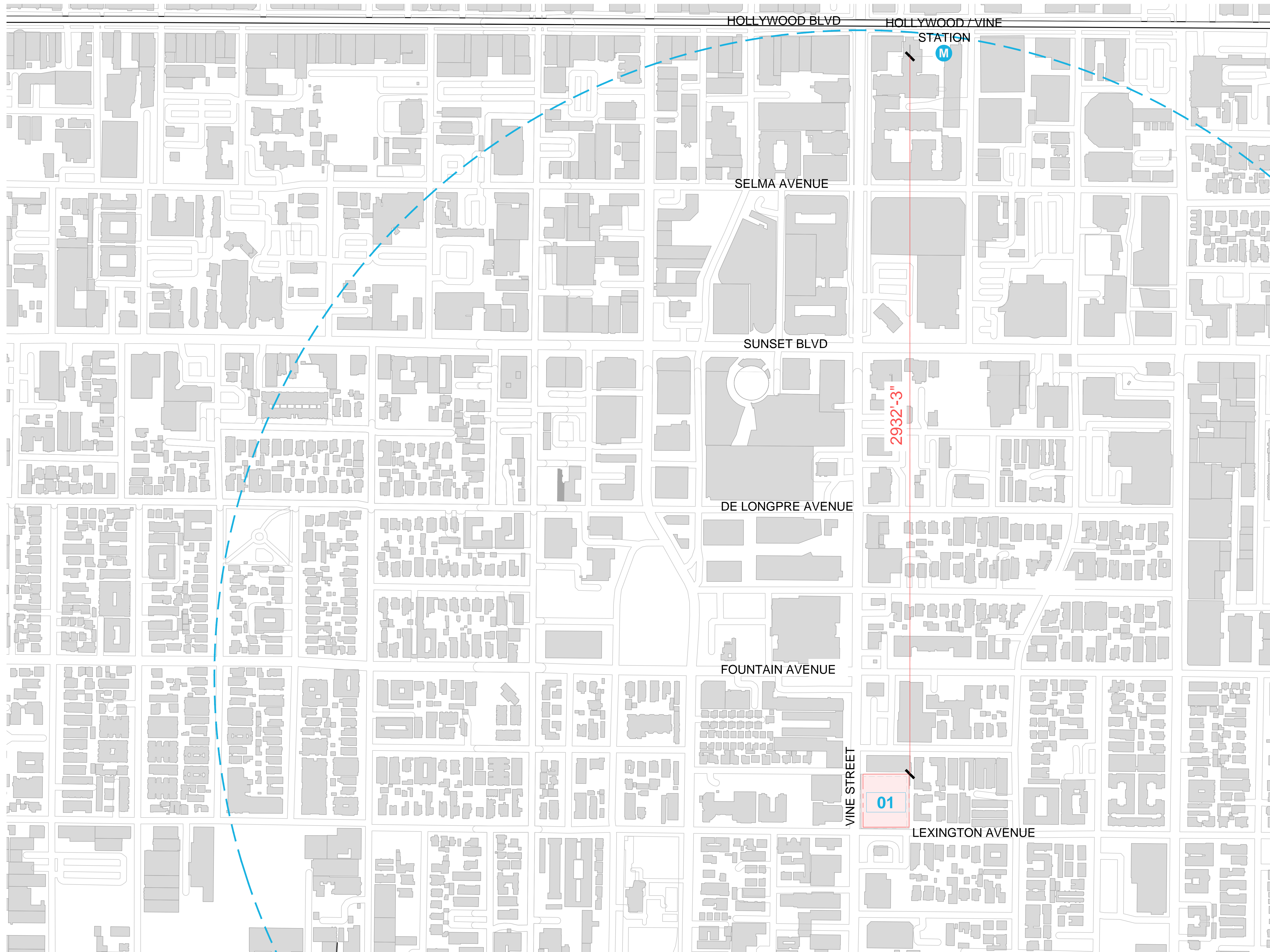

SYMBOLS LEGEND

- PROJECT SITE
- 2,640 FEET (0.5 M) RADIUS
- M METRO STATION

CALLOUT LEGEND

- 01 PROJECT SITE



Architecture + Planning
888.456.5849
ktgy.com

Grubb Properties
4601 Park Road, Suite 450
Charlotte, NC 28209

1200 VINE STREET
LOS ANGELES, CA # 2021-1034

CONCEPTUAL DESIGN
APRIL 11, 2023

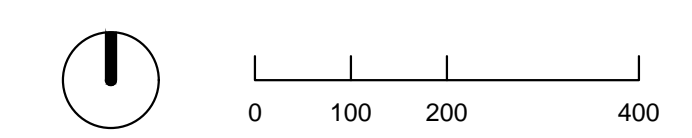

VICINITY MAP
PROJECT VICINITY SUMMARY

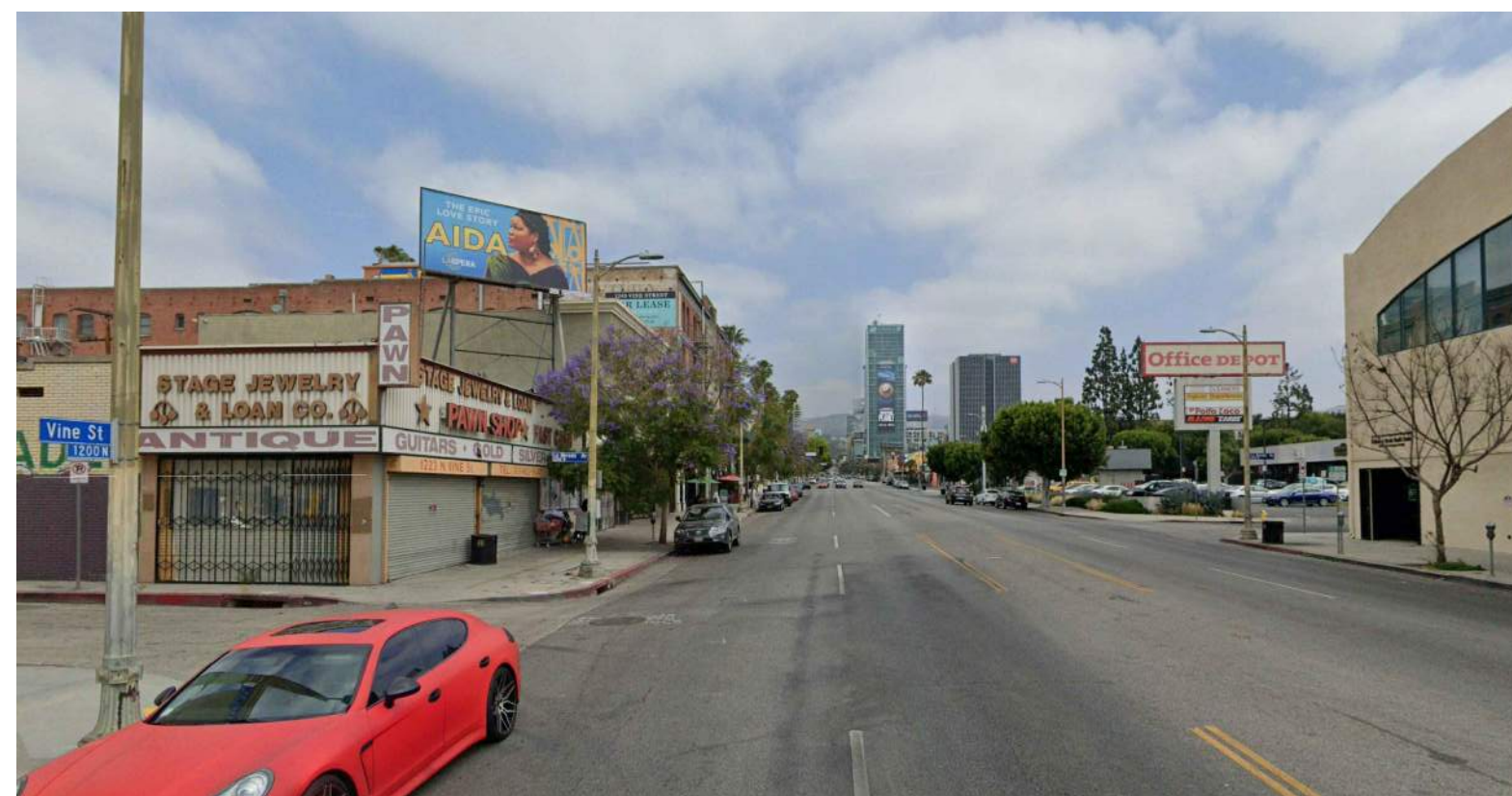

[1]



[5]

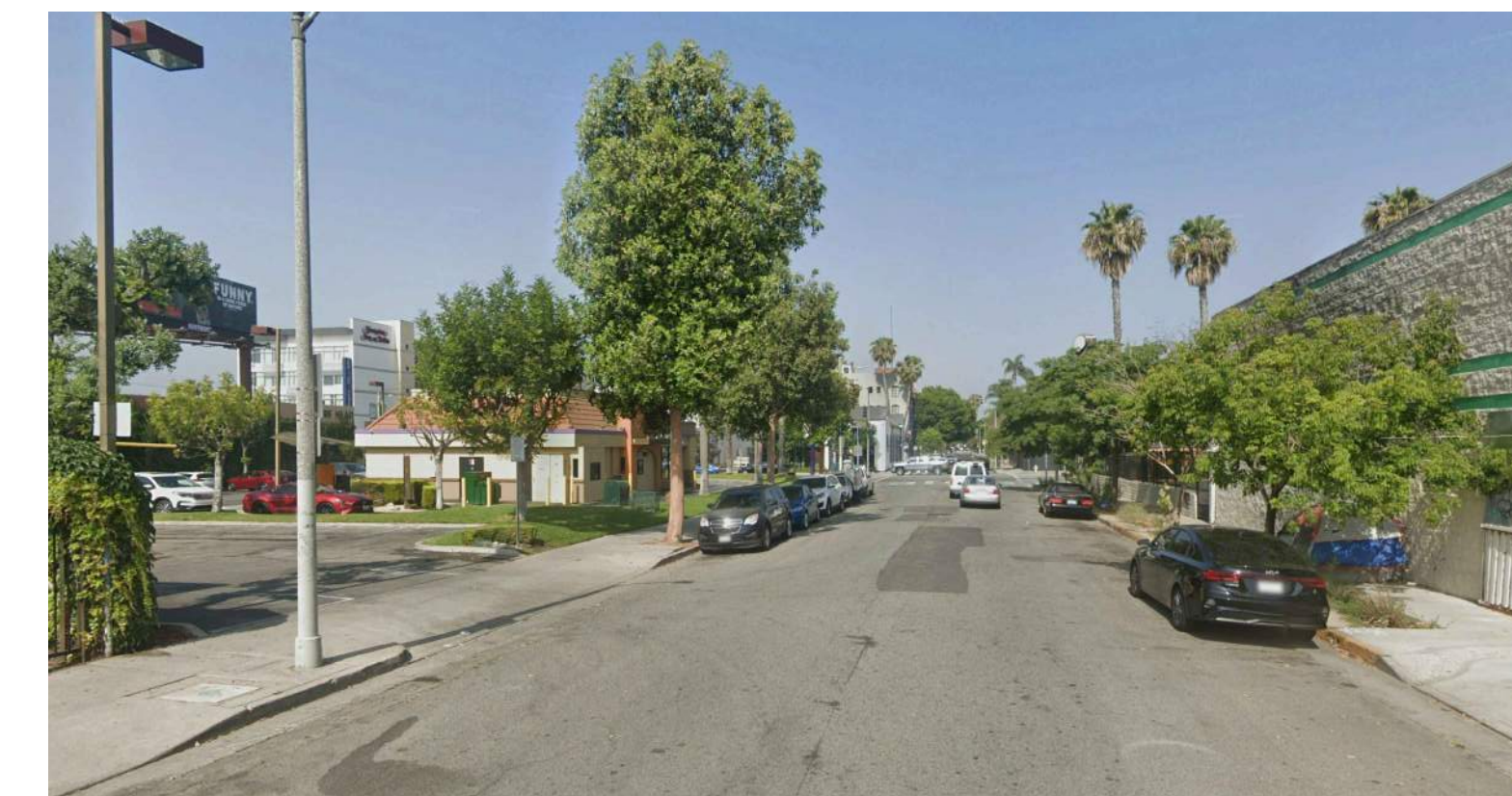

[7]



[2]

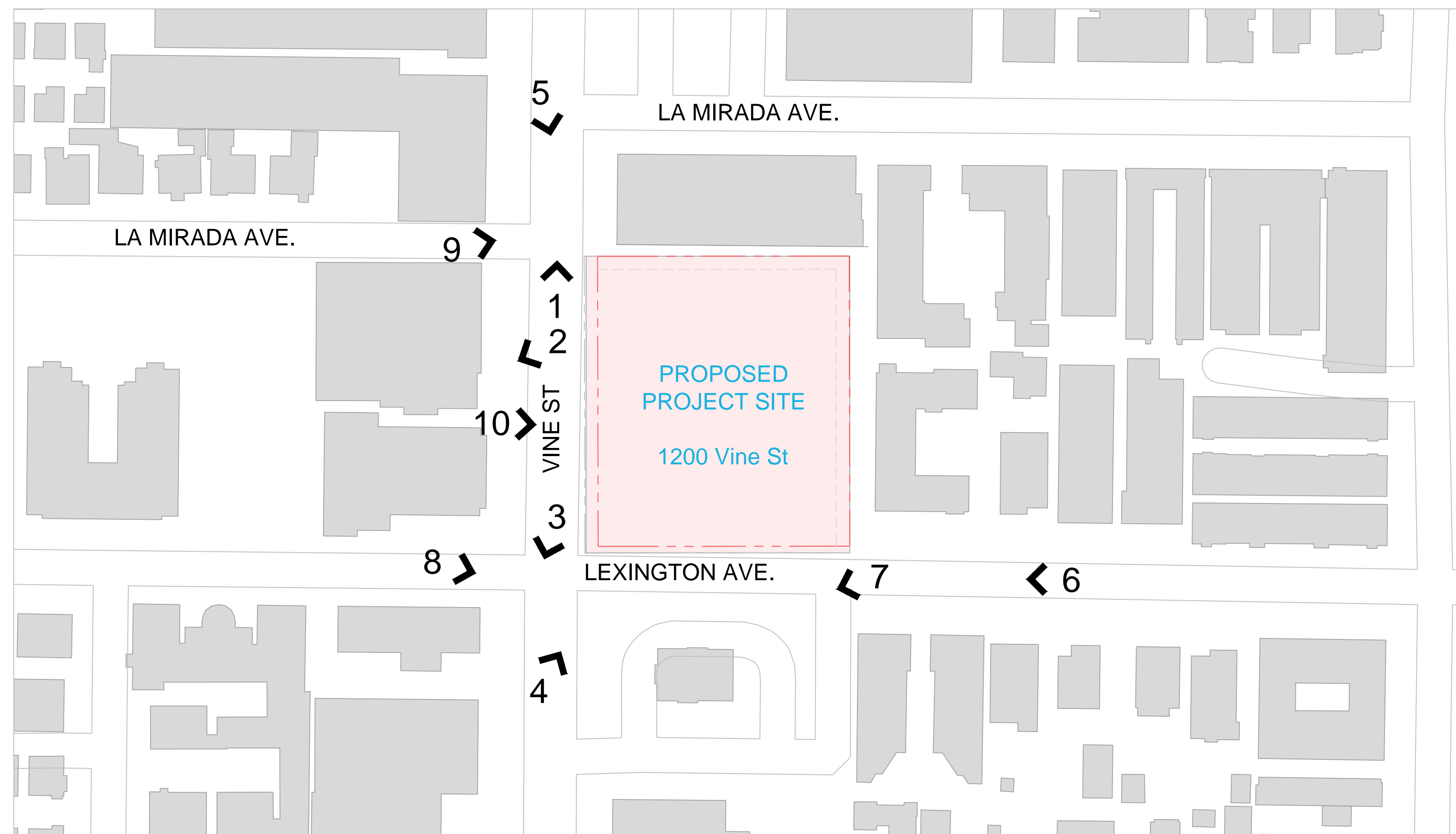

[8]



[3]



[9]



[4]



[6]

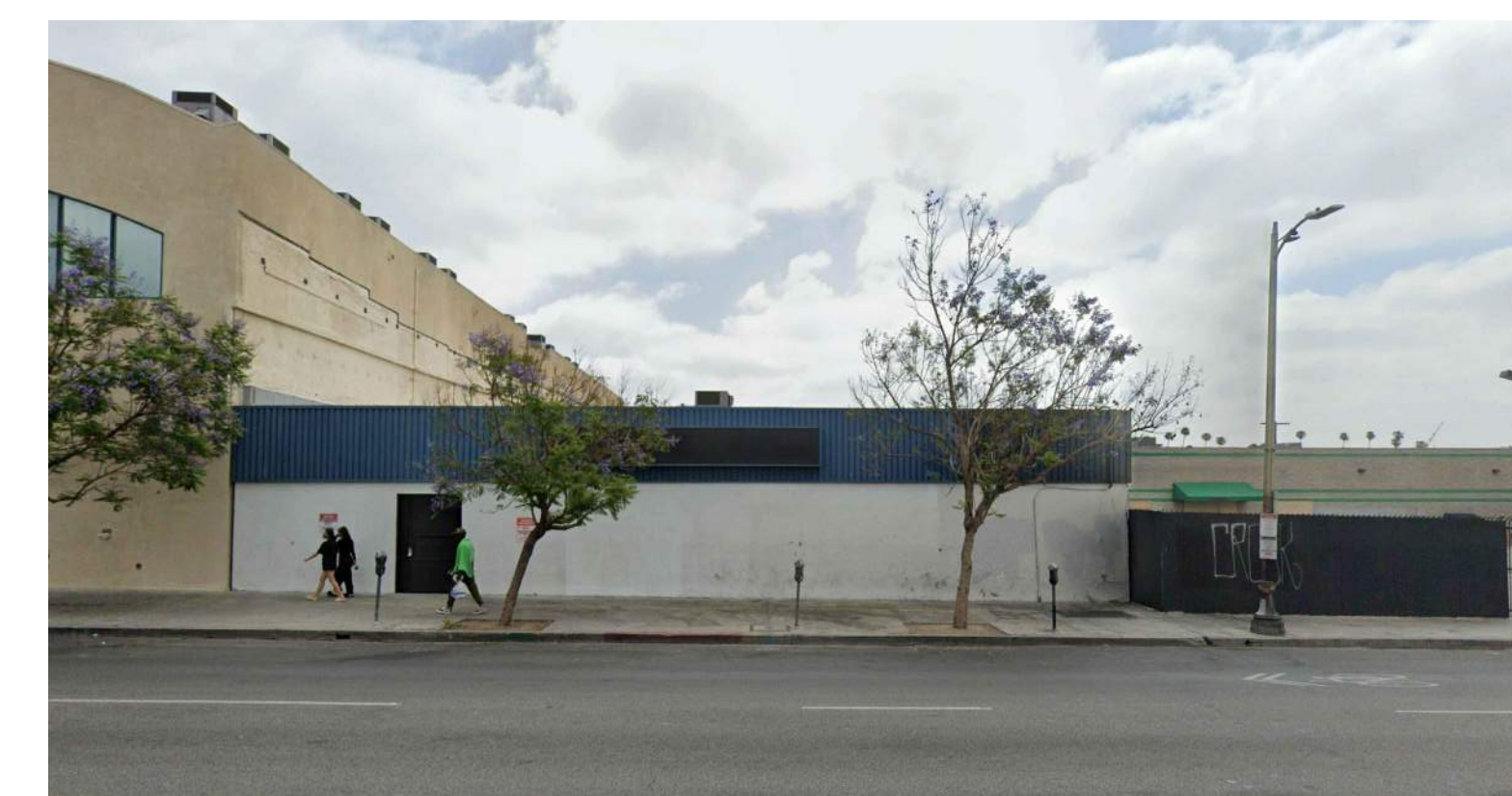

[10]



Architecture + Planning
888.456.5849
ktgy.com

Grubb Properties
4601 Park Road, Suite 450
Charlotte, NC 28209

1200 VINE STREET
LOS ANGELES, CA # 2021-1034

CONCEPTUAL DESIGN
APRIL 11, 2023

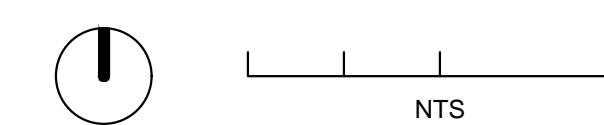

EXISTING CONTEXT

A0-2

PROJECT ZONING		
PROJECT NAME	1200 VINE ST	
PROJECT ADDRESS	1200-1218 N. VINE ST 6245-6247 W. LEXINGTON AVE. Los Angeles, CA 90027	
LAND USE	Highway Oriented Commercial	
ASSESSOR PARCEL #	5534-002-023 & 18	
ZONING	[Q] C2-2D	
LEGAL DESCRIPTION	<p>Refer to the Site Survey on sheet A0-4: "THE LAND REFERRED TO HEREIN BELOW IS SITUATED IN THE CITY OF LOS ANGELES, IN THE COUNTY OF LOS ANGELES, STATE OF CALIFORNIA, AND IS DESCRIBED AS FOLLOWS: PARCEL 1: THAT PORTION OF BLOCK 12 OF COLEGROVE, IN THE CITY OF LOS ANGELES, COUNTY OF LOS ANGELES, STATE OF CALIFORNIA, AS PER MAP RECORDED IN BOOK 53 PAGE 10 OF MISCELLANEOUS RECORDS, IN THE OFFICE OF COUNTY RECORDER OF SAID COUNTY, DESCRIBED AS FOLLOWS: BEGINNING AT THE INTERSECTION OF THE NORTH LINE OF LEXINGTON AVENUE (FORMERLY EMILITA AVENUE) WITH THE EAST LINE OF VINE STREET; THENCE NORTHERLY ALONG SAID EASE LINE OF VINE STREET 150 FEET; THENCE EAST PARALLEL WITH SAID NORTH LINE OF LEXINGTON AVENUE 198 FEET; THENCE SOUTHERLY PARALLEL WITH SAID EAST LINE OF VINE STREET 150 FEET TO THE NORTH LINE OF SAID LEXINGTON AVENUE; THENCE WESTERLY ALONG SAID NORTHERLY LINE TO THE POINT OF BEGINNING.</p> <p>PARCEL 2: THAT PORTION OF BLOCK 12 OF COLEGROVE, IN THE CITY OF LOS ANGELES, COUNTY OF LOS ANGELES, STATE OF CALIFORNIA, AS PER MAP RECORDED IN BOOK 53 PAGE 10 OF MISCELLANEOUS RECORDS OF SAID COUNTY, DESCRIBED AS PARCELS NO. 2 AND NO. 3 IN DEED TO CITY OF LOS ANGELES RECORDED IN BOOK 7822, PAGE 44 OF OFFICIAL RECORDS, IN THE OFFICE OF THE COUNTY RECORDER OF SAID COUNTY."</p>	
COMBINED SITE AREA	40,786	0.936 AC
SETBACKS		
	REQUIRED	PROPOSED
FRONT (Lexington)	com. 0' _ Res. 0'	com. 0' _ Res. 0'
SIDE (Vine)	com. 0' _ Res. 0'	com. 0' _ Res. 0'
SIDE (Abutting Prop.)	com. 0' _ Res. 10'	com. 0' _ Res. 10'
REAR (Abutting Prop.)	com. 0' _ Res. 20'	com. 0' _ Res. 10'

PROJECT SUMMARY & DATA		
LOT AREA	40,786 SF	0.936 AC
DENSITY		
C2-1D ZONE (BASE) 1/400SF 102 UNITS		DB AB-2345 47.5% INCREASE 151 UNITS 16% VLI UNITS - 17 UNITS
PROPOSED DENSITY	161.3 DU/AC	
FAR		
PROPOSED FAR	138,765 SF	3.40 :1
PROGRAM	RETAIL	3,690 SF
	LEASING	3,660 SF
	FITNESS	1,220 SF
	CLUB ROOMS	1,100 SF
	OTHER AMENITY	4,015 SF
	RESIDENTIAL NRSF	102,876 SF
PROPOSED MIX		
STUDIO	16 UNITS	11% AVE. 412 SF
1-BED	95 UNITS	63% AVE. 575 SF
2-BED	40 UNITS	26% AVE. 1,040 SF
TOTAL	151 UNITS	100% AVE. 681 SF
HEIGHT		
ALLOWABLE	UNLIMITED	
PROPOSED	87'-0" _ 7 STORIES	
PARKING		
REQUIRED	83 SPACES	
PROPOSED	87 SPACES	
OPEN SPACE		
REQUIRED	16,100 SF	
PROPOSED	19,065 SF	

FAR TABLE		
LOT SIZE: 40,786 SQFT		
	FAR	SQFT PERMITTED
C2-1D ZONE	.5 :1	20,393 SF
PROPOSED	3.40 :1	138,765 SF

INCENTIVES			
	BASE ZONING (C2-1D ZONE)	DENSITY BONUS AB 2345	PROVIDED
FAR	0.5:1 20,393 SF	3.0:1 122,358 SF	3.40:1 138,765 SF
SETBACKS	FRONT: COM. 0' _ RES. 0' SIDE (Vine): COM. 0' _ RES. 10' SIDE: COM. 0' _ RES. 10' REAR: COM. 0' _ RES. 20'	FRONT: COM. 0' _ RES. 0' SIDE (Vine): COM. 0' _ RES. 10' SIDE: COM. 0' _ RES. 10' REAR: COM. 0' _ RES. 20'	FRONT: COM. 0' _ RES. 0' SIDE (Vine): COM. 0' _ RES. 0' SIDE: COM. 0' _ RES. 10' REAR: COM. 0' _ RES. 10' (50% REDUCTION IN THE REAR SETBACK)

PARKING REQUIRED						
REQUIRED PARKING	RESIDENTIAL					
	UNIT COUNT		AB 2345		Included in the total count	
STUDIO UNITS	16	10.6%	0.5 PER UNIT	8	ADA REQ'D	EV READY
ONE BEDROOM UNITS	95	62.9%	0.5 PER UNIT	48	2% of total standrad stalls + 2% of EV Ready stalls	30% of total, inc. 10% EVCS
TWO BEDROOM UNITS	40	26.5%	0.5 PER UNIT	20		
	151 UNITS		TOTAL	76 SPACES	2 SPACES	23 SPACES
REQUIRED PARKING	COMMERCIAL					
	GROUND FLOOR RETAIL	3,690 SF	2 PER 1,000 SF	10% REDUCTION	7 SPACES	1 SPACES
TOTAL			AB 2345:	83 SPACES	3 SPACES	26 SPACES

PARKING PROVIDED						
PROVIDED PARKING	RESIDENTIAL					
	COMPACT	STANDARD	EV READY	EV READY ADA	ADA	TOTAL
1st FLOOR	3	17	15	0	1	36
2nd FLOOR	6	27	9	1	1	44
TOTAL OF EACH STALL TYPE	9	44	24	1	2	
TOTAL PROVIDED	80 SPACES					0.53 SPACE/UNIT

PROVIDED PARKING	COMMERCIAL					
	COMPACT	STANDARD	EV READY	EV READY ADA	ADA	TOTAL
1st FLOOR	0	3	3	1	0	7
2nd FLOOR	0	0	0	0	0	0
TOTAL OF EACH STALL TYPE	0	3	3	1	0	
TOTAL PROVIDED	7 SPACES					1 SPACE / 530 SF

OPEN SPACE			
REQUIRED	OPEN SPACE _ PER R4 ZONE		
STUDIO UNITS	16	100 PER UNIT	1,600
ONE BEDROOM UNITS	95	100 PER UNIT	9,500
TWO BEDROOM UNITS	40	125 PER UNIT	5,000
	151 UNITS	REQUIRED OPEN SPACE	16,100 SF

PROVIDED	OPEN SPACE
PRIVATE DECKS (50sf max.)	6,050 SF
OUTDOOR PLAZA - L1	1,200 SF
PODIUM COURTYARD - L3	5,970 SF
ROOF DECK A - L7	1,200 SF
ROOF DECK B - L7	620 SF
INDOOR AMENITIES (max. 25% of total req.)	4,025 SF
TOTAL	19,065 SF

BIKE PARKING			
LONG-TERM			
DWELLING UNITS	RATIO	DU	TOTAL
1-25 DU		1	25
26-100 DU	0.67	75	50.0
101-200 DU	0.5	51	25.5
COMMERCIAL	RATIO / SQFT	SQFT	TOTAL
	2000	3,690 SF	1.845
TOTAL REQUIRED			102.3
TOTAL PROPOSED			103

SHORT-TERM			
DWELLING UNITS	RATIO	DU	TOTAL
1-25 DU	0.10	25	2.5
26-100 DU	0.07	75	5.0
101-200 DU	0.05	51	2.6
COMMERCIAL	RATIO / SQFT	SQFT	TOTAL
	2000	3,690 SF	1.845
TOTAL REQUIRED			11.9
TOTAL PROPOSED			12



Architecture + Planning
888.456.5849
ktgy.com

Grubb Properties
4601 Park Road, Suite 450
Charlotte, NC 28209

1200 VINE STREET
LOS ANGELES, CA # 2021-1034

CONCEPTUAL DESIGN
APRIL 11, 2023

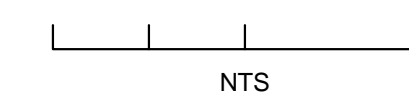

PROJECT DATA

A0-3

FLOOR AREA SUMMARY

FLOOR / LEVEL	APARTMENT UNITS	RESIDENTIAL UNIT AREA	COMMON AREAS / CIRCULATION	AMENITY/ LOBBY / RETAIL AREA	BALC. AREA (INCL. IN FAR)	TOTAL FLOOR AREA	GARAGE / MECH AREA	GROSS BUILDING AREA
Level 1	0 UNITS	0 SF	1,380 SF	9,040 SF	0 SF	10,420 SF	22,262 SF	32,682 SF
Level 2	7 UNITS	5,389 SF	2,135 SF	2,140 SF	72 SF	9,736 SF	20,585 SF	30,321 SF
Level 3	27 UNITS	18,091 SF	3,308 SF	2,320 SF	466 SF	24,185 SF	0 SF	24,185 SF
Level 4	30 UNITS	20,564 SF	3,088 SF	0 SF	533 SF	24,185 SF	0 SF	24,185 SF
Level 5	30 UNITS	20,564 SF	3,088 SF	0 SF	533 SF	24,185 SF	0 SF	24,185 SF
Level 6	30 UNITS	20,564 SF	3,088 SF	0 SF	533 SF	24,185 SF	0 SF	24,185 SF
Level 7	27 UNITS	17,704 SF	2,800 SF	1,365 SF	0 SF	21,869 SF	0 SF	21,869 SF
Total	151 UNITS	102,876 SF	18,887 SF	14,865 SF	2,137 SF	138,765 SF	42,847 SF	181,612 SF

UNIT DATA								
UNITS	S1	A1	A2	A3	B1	B3-angled	B3	TOTALS
UNIT SQFT	412	496	585	660	952	1,130	1,145	
BALCONY SQFT	60	60	70	50	90	143	85	
Levels 1	0	0	0	0	0	0	0	0
Levels 2	0	2	2	0	1	1	1	7
Levels 3	4	5	7	4	4	1	2	27
Levels 4	3	5	10	4	4	2	2	30
Levels 5	3	5	10	4	4	2	2	30
Levels 6	3	5	10	4	4	2	2	30
Levels 7	3	5	9	4	4	1	1	27
TOTALS	16	27	48	20	21	9	10	151 UNITS
	10.6%	17.9%	31.8%	13.2%	13.9%	6.0%	6.6%	
RENTABLE AREA	6,592	13,392	28,080	13,200	19,992	10,170	11,450	102,876 SQFT
	STUDIO	1 BEDROOM		2 BEDROOM				
TOTAL UNITS	16	95		40				151 UNITS
UNIT MIX	10.6%	62.9%		26.5%				
AVG SQFT	412	575		1,040				681 SQFT



Architecture + Planning
888.456.5849
ktgy.com

Grubb Properties
4601 Park Road, Suite 450
Charlotte, NC 28209

1200 VINE STREET
LOS ANGELES, CA # 2021-1034

CONCEPTUAL DESIGN
APRIL 11, 2023

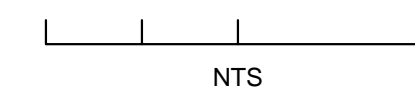

PROJECT DATA

A0-3A

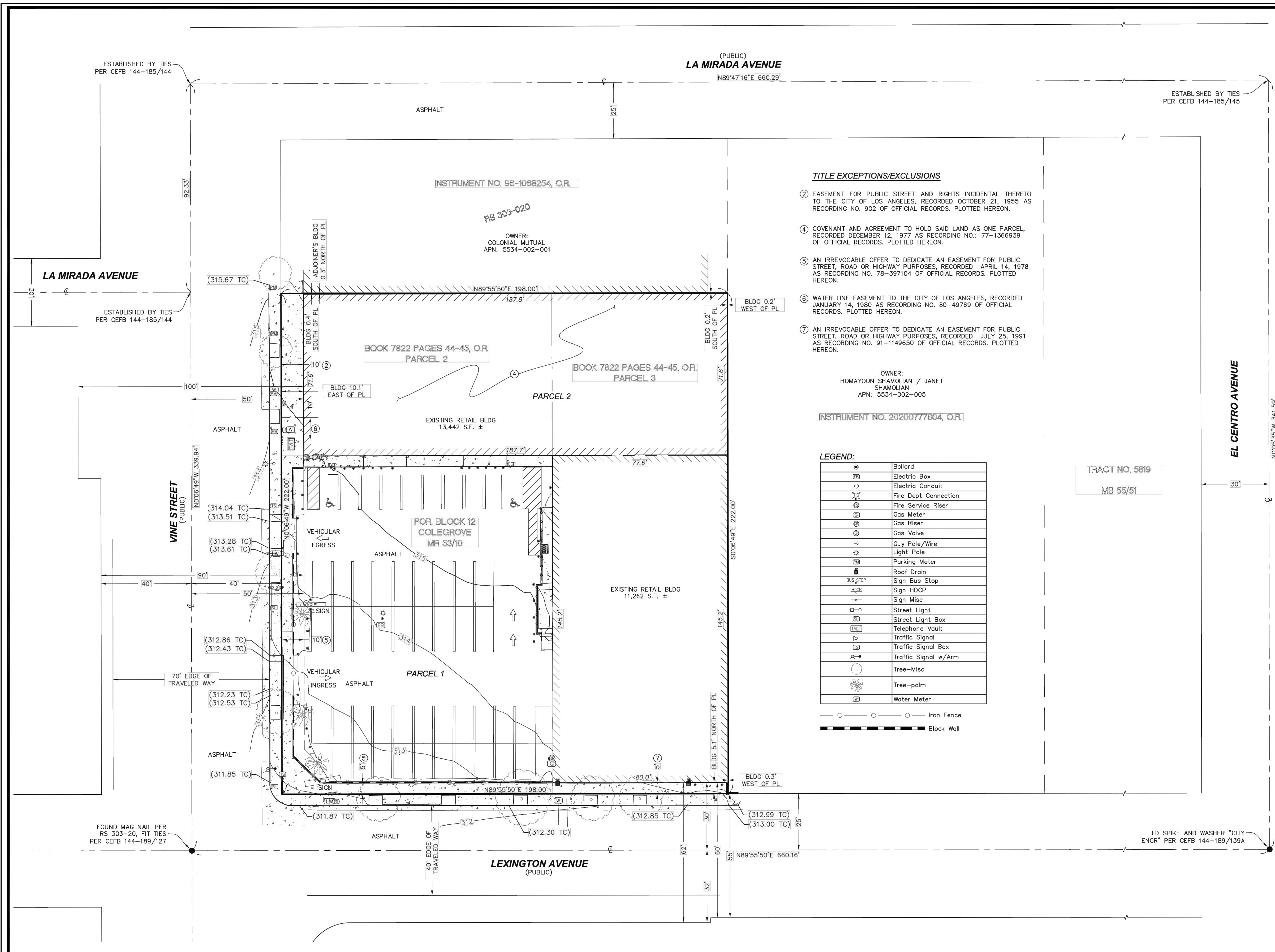

TITLE EXCEPTIONS/EXCLUSIONS

- ② EASEMENT FOR PUBLIC STREET AND RIGHTS INCIDENTAL THERETO TO THE CITY OF LOS ANGELES, RECORDED OCTOBER 21, 1955 AS RECORDING NO. 902 OF OFFICIAL RECORDS. PLOTTED HEREON.
- ④ COVENANT AND AGREEMENT TO HOLD SAID LAND AS ONE PARCEL, RECORDED DECEMBER 12, 1977 AS RECORDING NO.: 77-1366939 OF OFFICIAL RECORDS, PLOTTED HEREON.
- ⑤ AN IRREVOCABLE OFFER TO DEDICATE AN EASEMENT FOR PUBLIC STREET, ROAD OR HIGHWAY PURPOSES, RECORDED APRIL 14, 1978 AS RECORDING NO. 78-397104 OF OFFICIAL RECORDS. PLOTTED HEREON.
- ⑥ WATER LINE EASEMENT TO THE CITY OF LOS ANGELES, RECORDED JANUARY 14, 1980 AS RECORDING NO. 80-49769 OF OFFICIAL RECORDS. PLOTTED HEREON.
- ⑦ AN IRREVOCABLE OFFER TO DEDICATE AN EASEMENT FOR PUBLIC STREET, ROAD OR HIGHWAY PURPOSES, RECORDED JULY 25, 1991 AS RECORDING NO. 91-1149650 OF OFFICIAL RECORDS. PLOTTED HEREON.

OWNER:
HOMAYOON SHAMOLIAN / JANET SHAMOLIAN
APN: 5534-002-005

INSTRUMENT NO. 2020077804, O.R.

LEGEND:

●	Bollard
⊞	Electric Box
○	Electric Conduit
⚡	Fire Dept Connection
⊞	Fire Service Riser
⊞	Gas Meter
⊞	Gas Riser
⊞	Gas Valve
→	Guy Pole/Wire
⊞	Light Pole
⊞	Parking Meter
⊞	Roof Drain
⊞	Sign Bus Stop
⊞	Sign HDCP
⊞	Sign Misc
⊞	Street Light
⊞	Street Light Box
⊞	Telephone Vault
⊞	Traffic Signal
⊞	Traffic Signal Box
⊞	Traffic Signal w/Arm
⊞	Tree-Misc
⊞	Tree-palm
⊞	Water Meter

○ — Iron Fence
— — Block Wall

Revisions			
No.	Description	By	Date
1	CLIENT COMMENTS (REVISION TO EXC. ITEM 4)	JPG	10/13/2020

BASIS OF BEARINGS:
THE BASIS OF BEARINGS FOR THIS SURVEY IS THE CENTERLINE OF LEXINGTON AVENUE PER RS 303-20, I.E. N89°55'50"E.

BASIS OF ELEVATIONS:
THE BASIS OF ELEVATIONS FOR THIS SURVEY IS THE CITY OF LOS ANGELES BENCHMARK 12-13650, WIRE SPIKE IN W CURB VINE ST. 9FT N. OF LEXINGTON AVE N END. CB. EL = 311.692, NAVD 88.

ALTA/NSPS LAND TITLE SURVEY
PORTION BLOCK 12
COLEGROVE, M.R. 53/10
LOS ANGELES, CA

Drawn By: JPG
Checked By:

Project No. 20-121
Date: Sheet 1 of 1

PROJECT NAME:
VINE STREET

CERTIFICATION

TO MIG REAL ESTATE AND/OR ITS ASSIGNS AND SUCCESSORS AND CHICAGO TITLE INSURANCE COMPANY:
THIS IS TO CERTIFY THAT THIS MAP OR PLAT AND THE SURVEY ON WHICH IT IS BASED WERE MADE IN ACCORDANCE WITH THE 2016 MINIMUM STANDARD DETAIL REQUIREMENTS FOR ALTA/NSPS LAND TITLE SURVEYS, JOINTLY ESTABLISHED AND ADOPTED BY ALTA AND NSPS, AND INCLUDES ITEMS 1, 2, 3, 4, 5, 6A, 7A, 7B1, 8, 9, 10, 11, 13, 14, 16, 17 & 20 OF TABLE A THEREOF. THE FIELD WORK WAS COMPLETED ON 09/16/2020.

DATE OF PLAT OR MAP: 09/24/2020
DATE OF LAST REVISION: 10/13/2020

JOHN P. GERVAIS
PLS 8674



SURVEYOR'S NOTES

THIS SURVEY WAS MADE ON THE GROUND UNDER MY SUPERVISION.
INFORMATION SHOWN HEREON IS BASED ON CHICAGO TITLE INSURANCE COMPANY ORDER# 00129357-021-PS4-JC, DATED AS OF JULY 31, 2020, AS WELL AS A COPY OF EACH INSTRUMENT LISTED THEREIN, AND THE SUBJECT LAND AND EACH PARCEL THEREOF DESCRIBED IN THIS SURVEY IS THE SAME LAND AS DESCRIBED IN THE TITLE COMMENT INDICATED THEREIN.
THE SUBJECT PROPERTY HAS DIRECT PHYSICAL ACCESS TO VINE STREET AND LEXINGTON AVENUE, BOTH PUBLICLY DEDICATED AND MAINTAINED ROADS.

TABLE "A" ITEMS

- 2. PROPERTY ADDRESS: 1212-1218 VINE ST., LOS ANGELES, CA PER TITLE REPORT.
- 3. PROPERTY IS IN ZONE X: 0.2% ANNUAL CHANCE FLOOD HAZARD, PER FEMA MAP 06037C1605F, EFFECTIVE ON 09/26/2008.
- 4. GROSS AREA = 43,956 S.F. / 1.01 AC. ±
- 5. VERTICAL RELIEF SHOWN HEREON.
- 6(a). ZONING: C2-10
A ZONING REPORT OR LETTER WAS NOT PROVIDED BY THE CLIENT. IT IS THE RESPONSIBILITY OF THE INSURED TO VERIFY THE ZONING INFORMATION.
- 7(a)(b). EXTERIOR DIMENSIONS OF ALL BUILDINGS & SQUARE FOOTAGE OF EXTERIOR BUILDING AT GROUND LEVEL SHOWN HEREON.
- 8. SUBSTANTIAL FEATURES OBSERVED IN THE PROCESS OF CONDUCTING THE SURVEY ARE SHOWN HEREON.
- 9. PARKING: 28 REGULAR, 10 TANDEM, 2 ACCESSIBLE. TOTAL = 50 STALLS.
- 10. N/A
- 11. LOCATION OF UTILITIES EXISTING ON OR SERVING THE SURVEYED PROPERTY AS DETERMINED BY OBSERVED EVIDENCE ONLY.
- 13. ADJACENT OWNERS SHOWN HEREON.
- 14. DISTANCE TO NEAREST INTERSECTION SHOWN HEREON. (SUBJECT PROPERTY IS ADJACENT TO THE NEAREST INTERSECTION).
- 16. THERE IS NO OBSERVABLE EVIDENCE OF EARTH MOVING WORK, BUILDING CONSTRUCTION OR BUILDING ADDITIONS WITHIN RECENT MONTHS.
- 17. SURVEYOR IS NOT AWARE OF ANY PROPOSED CHANGES IN STREET RIGHT OF WAY LINES. THERE IS NO EVIDENCE OF RECENT STREET OR SIDEWALK CONSTRUCTION OR REPAIRS OBSERVED IN THE PROCESS OF CONDUCTING THE FIELDWORK.

LEGAL DESCRIPTION

THE LAND REFERRED TO HEREIN BELOW IS SITUATED IN THE CITY OF LOS ANGELES, IN THE COUNTY OF LOS ANGELES, STATE OF CALIFORNIA, AND IS DESCRIBED AS FOLLOWS:
PARCEL 1:
THAT PORTION OF BLOCK 12 OF COLEGROVE, IN THE CITY OF LOS ANGELES, COUNTY OF LOS ANGELES, STATE OF CALIFORNIA, AS PER MAP RECORDED IN BOOK 53 PAGE 10 OF MISCELLANEOUS RECORDS, IN THE OFFICE OF THE COUNTY RECORDER OF SAID COUNTY, DESCRIBED AS FOLLOWS: BEGINNING AT THE INTERSECTION OF THE NORTH LINE OF LEXINGTON AVENUE (FORMERLY EMILITA AVENUE) WITH THE EAST LINE OF VINE STREET; THENCE NORTHERLY ALONG SAID EAST LINE OF VINE STREET 150 FEET; THENCE EAST PARALLEL WITH SAID NORTH LINE OF LEXINGTON AVENUE 198 FEET; THENCE SOUTHERLY PARALLEL WITH SAID EAST LINE OF VINE STREET 150 FEET TO THE NORTH LINE OF SAID LEXINGTON AVENUE; THENCE WESTERLY ALONG SAID NORTHERLY LINE TO THE POINT OF BEGINNING.
PARCEL 2:
THAT PORTION OF BLOCK 12 OF COLEGROVE, IN THE CITY OF LOS ANGELES, COUNTY OF LOS ANGELES, STATE OF CALIFORNIA, AS PER MAP RECORDED IN BOOK 53, PAGE 10 OF MISCELLANEOUS RECORDS, OF SAID COUNTY, DESCRIBED AS PARCELS NO. 2, AND NO. 3 IN DEED TO CITY OF LOS ANGELES, RECORDED IN BOOK 7822, PAGE 44 OF OFFICIAL RECORDS, IN THE OFFICE OF THE COUNTY RECORDER OF SAID COUNTY.
APN: 5534-002-023 & 018

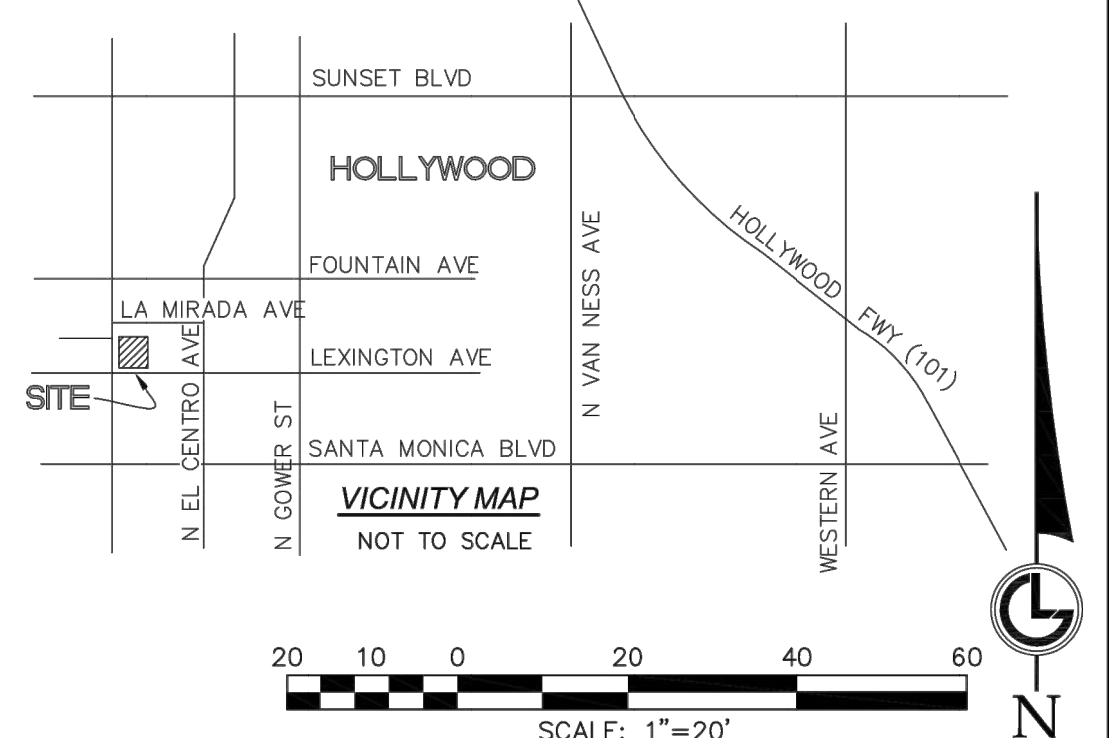

Architecture + Planning
888.456.5849
ktgy.com

Grubb Properties
4601 Park Road, Suite 450
Charlotte, NC 28209

1200 VINE STREET
LOS ANGELES, CA # 2021-1034

CONCEPTUAL DESIGN
APRIL 11, 2023

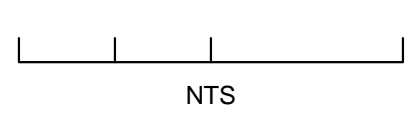

SITE SURVEY

A0-4

LG LAND SURVEYING, INC.
"Quality Service You Can Count On"
30355 CALLEJO FELIZ TER
VALLEY CENTER, CA 92682
p: 619-535-1172
f: 619-618-1972
www.lglstnc.com

PROJECT SUMMARY

1200 VINE STREET
LOS ANGELES, CA

ZONING: [Q] C2-2D

AREA: 0.936 ACRES (40,787 SF)

UNITS: 151 DU

DENSITY: 161.3 DU/AC

LA MIRADA AVENUE

COMMERCIAL FRONTAGE = 97.8'
BUILDING FRONTAGE = 198' - 26.4' (GARAGE OPENING) = 171.6'
97.8'/171.6' = 57% > 35% MIN. FOR MIXED USE



10-FOOT WIDE DEDICATION TO FUTURE RIGHT-OF-WAY EXPANSION (2,180 SF)
5-FOOT WIDE DEDICATION TO FUTURE RIGHT-OF-WAY EXPANSION (960 SF)

COMMERCIAL FRONTAGE = 46.75'
BUILDING FRONTAGE = 173.5' - 47' (GARAGE OPENING & UTILITIES) = 126.5'
46.75'/126.5' = 36.9% > 35% MIN. FOR MIXED USE



Architecture + Planning
888.456.5849
ktgy.com

Grubb Properties
4601 Park Road, Suite 450
Charlotte, NC 28209

1200 VINE STREET
LOS ANGELES, CA # 2021-1034

CONCEPTUAL DESIGN
APRIL 11, 2023



SITE PLAN
PROJECT SUMMARY

A1-0

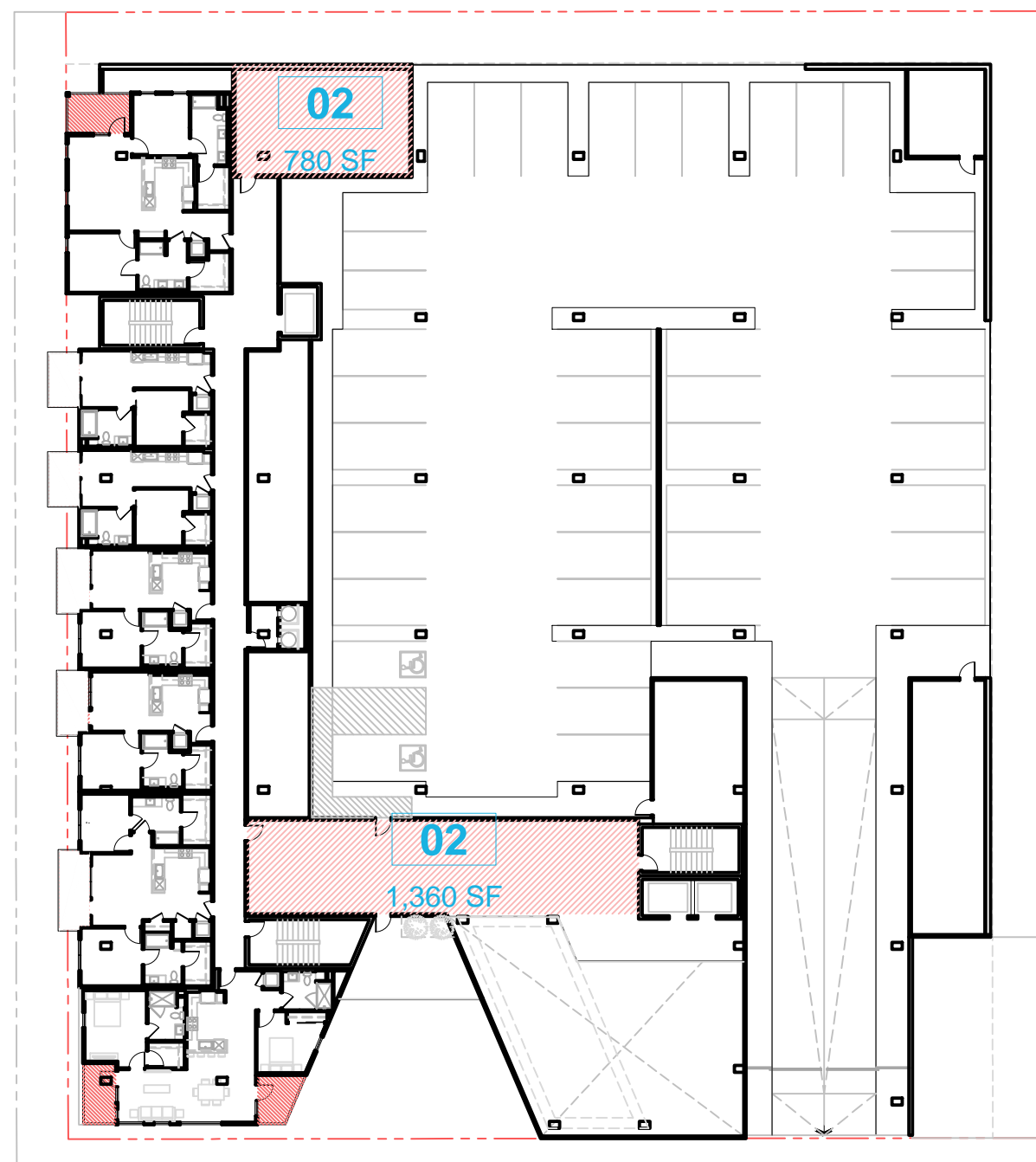

LEVEL 02

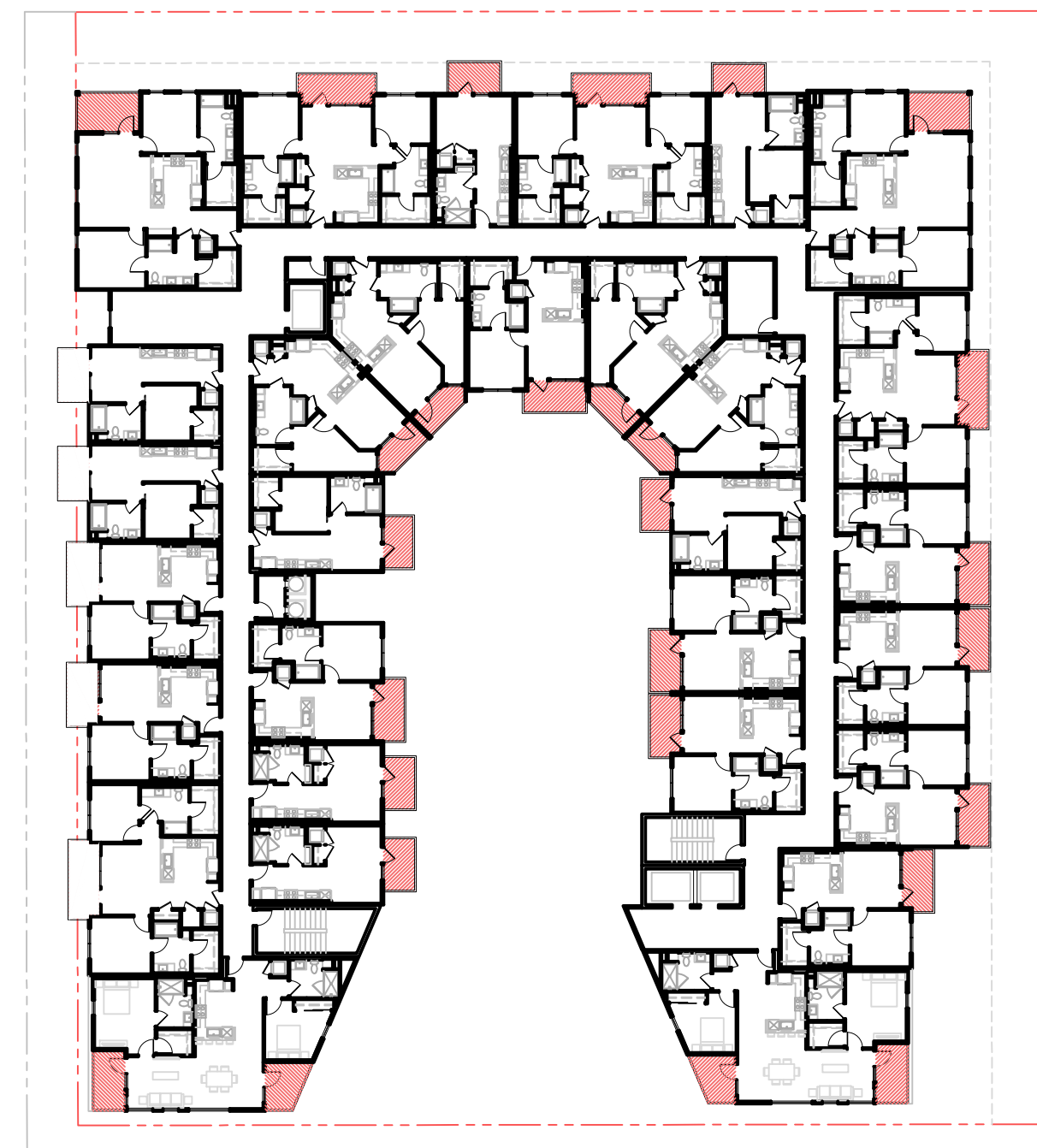

LEVEL 04-06

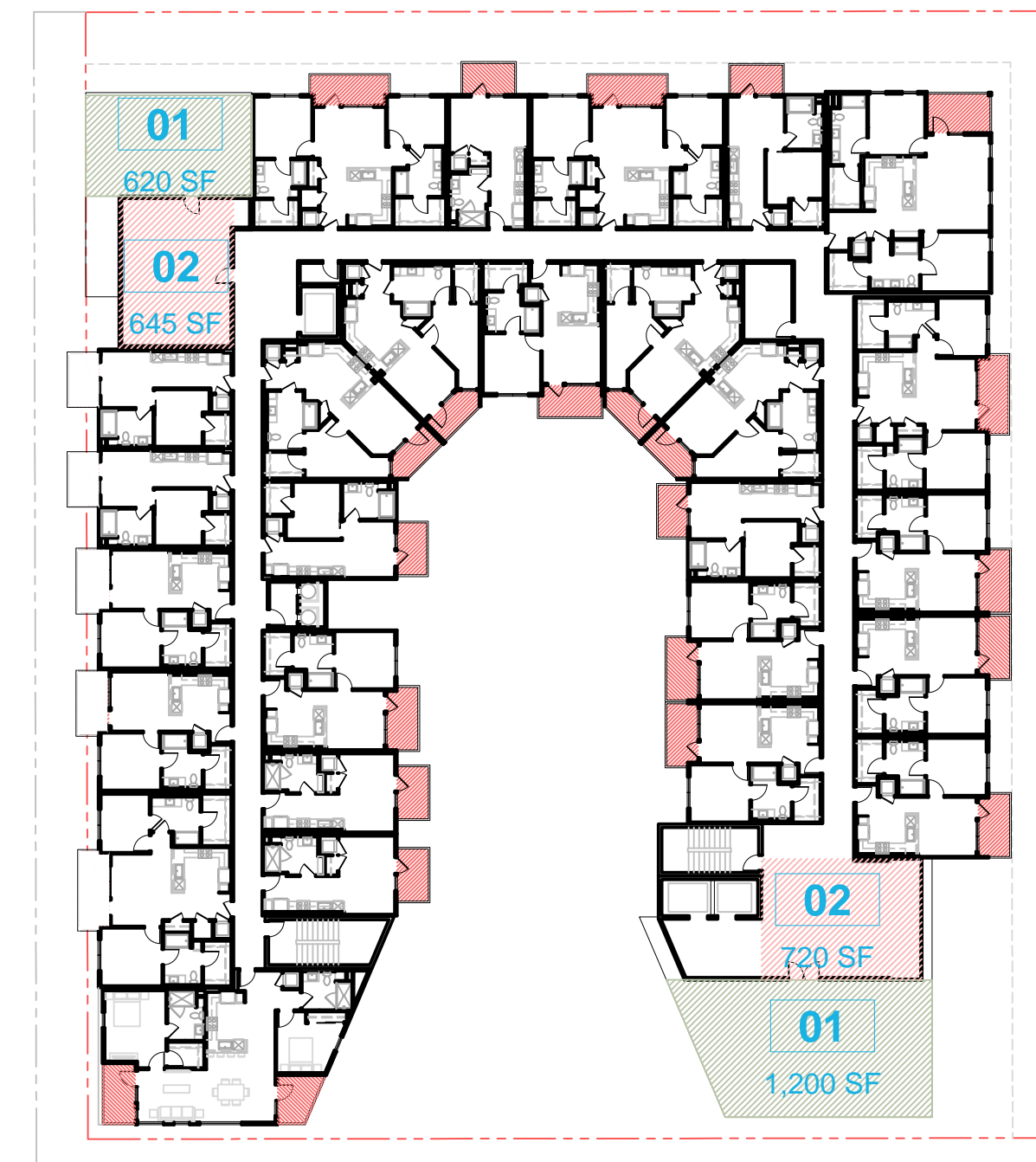

LEVEL 07

COLOR LEGEND

- 1. OUTDOOR COMMON OPEN SPACE
- 2. INDOOR COMMON OPEN SPACE
- 3. PRIVATE OPEN SPACE
 - BALCONIES WITH 6' MIN DIM IN LENGTH AND WIDTH
 - SEE A5-0 UNIT PLAN SHEETS FOR BALCONY DIMS

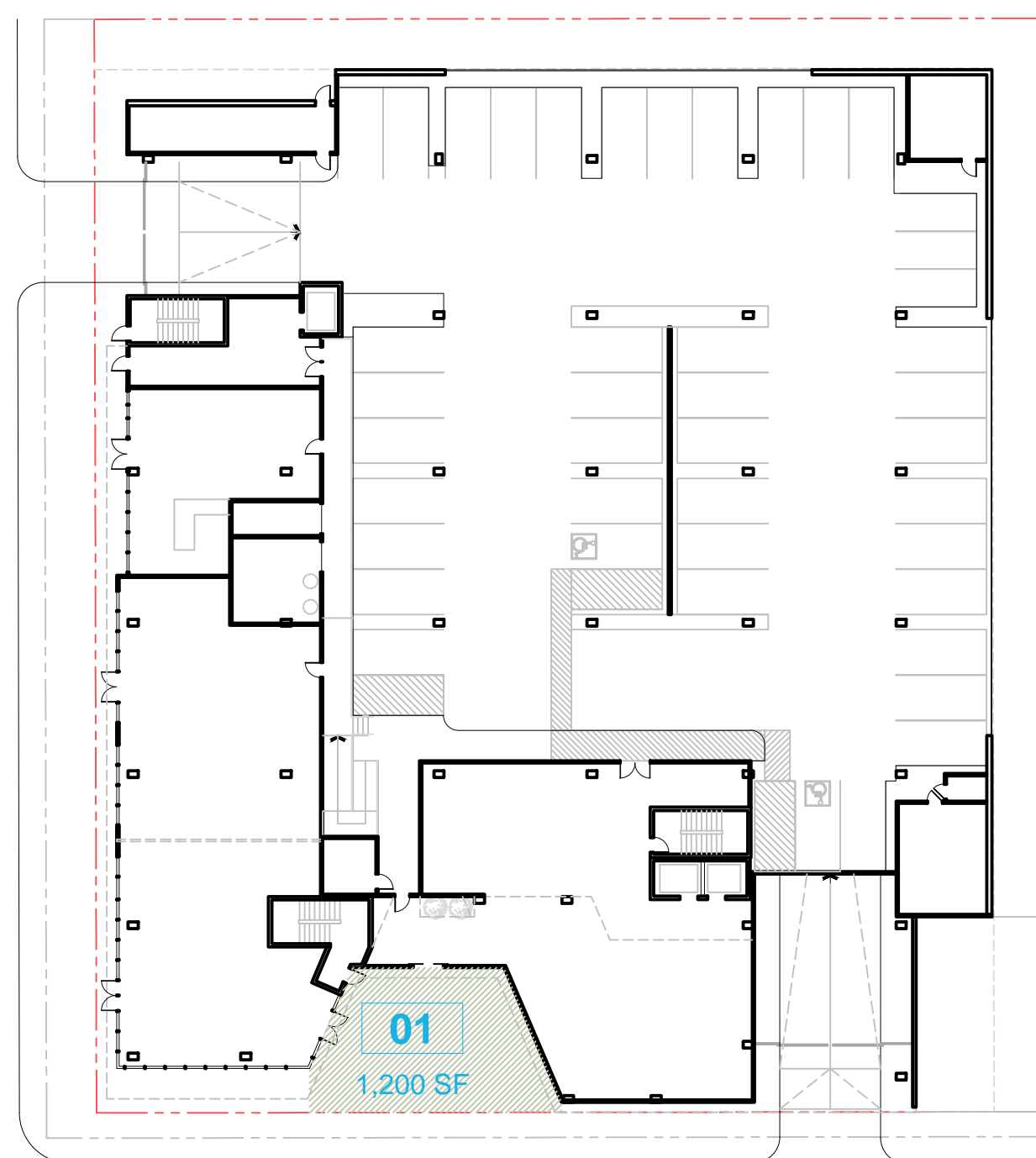

LEVEL 01

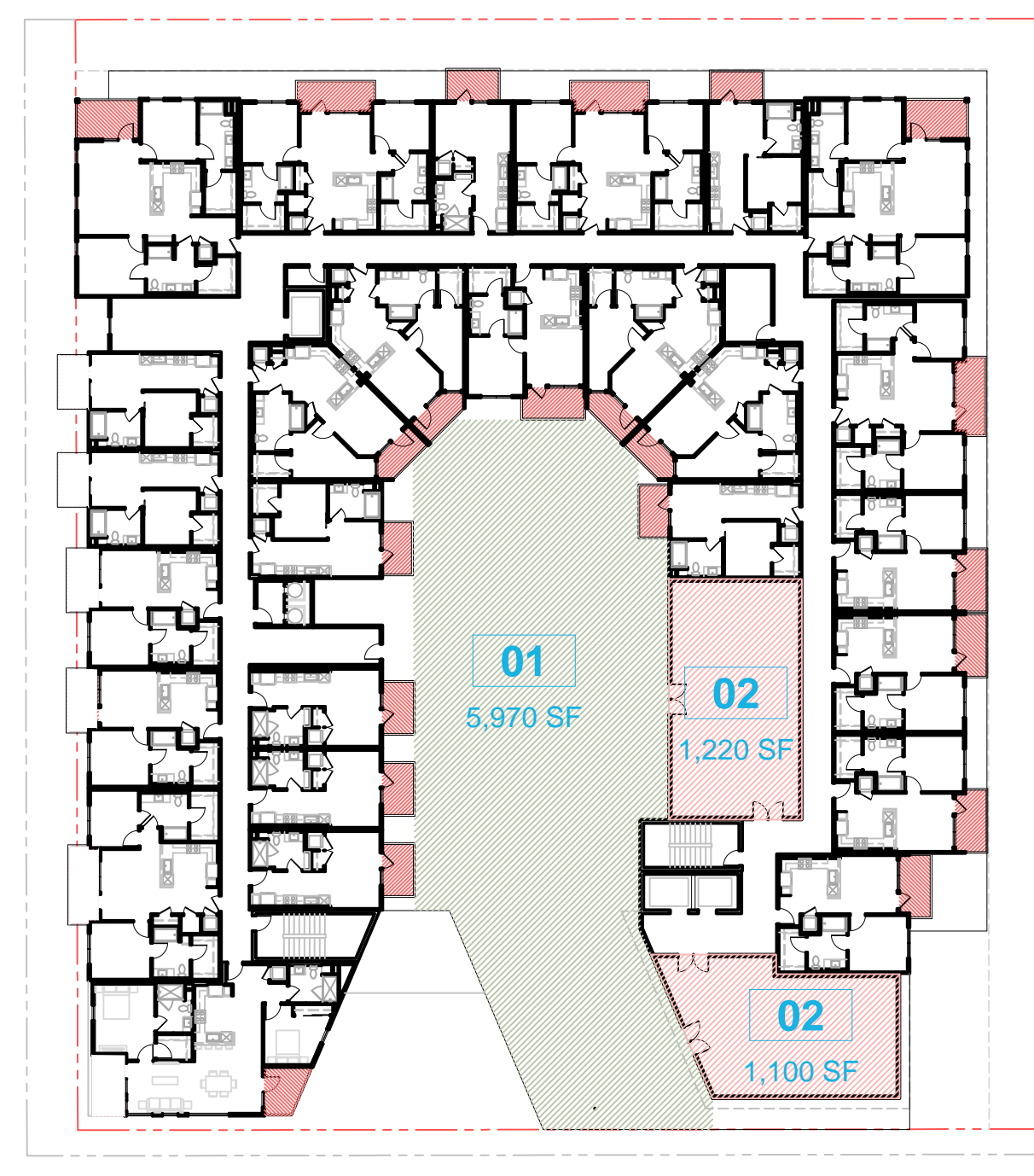

LEVEL 03

OPEN SPACE			
REQUIRED	OPEN SPACE _ PER R4 ZONE		
STUDIO UNITS	16	100 PER UNIT	1,600
ONE BEDROOM UNITS	95	100 PER UNIT	9,500
TWO BEDROOM UNITS	40	125 PER UNIT	5,000
	151 UNITS	REQUIRED OPEN SPACE	16,100 SF

PROVIDED	OPEN SPACE
PRIVATE DECKS (50sf max.)	6,050 SF
OUTDOOR PLAZA - L1	1,200 SF
PODIUM COURTYARD - L3	5,970 SF
ROOF DECK A - L7	1,200 SF
ROOF DECK B - L7	620 SF
INDOOR AMENITIES (max. 25% of total req.)	4,025 SF
TOTAL	19,065 SF



Architecture + Planning
888.456.5849
ktgy.com

Grubb Properties
4601 Park Road, Suite 450
Charlotte, NC 28209

1200 VINE STREET
LOS ANGELES, CA # 2021-1034

CONCEPTUAL DESIGN
APRIL 11, 2023

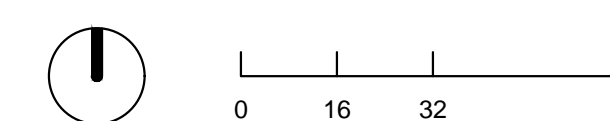

OPEN SPACE EXHIBIT

A1-2

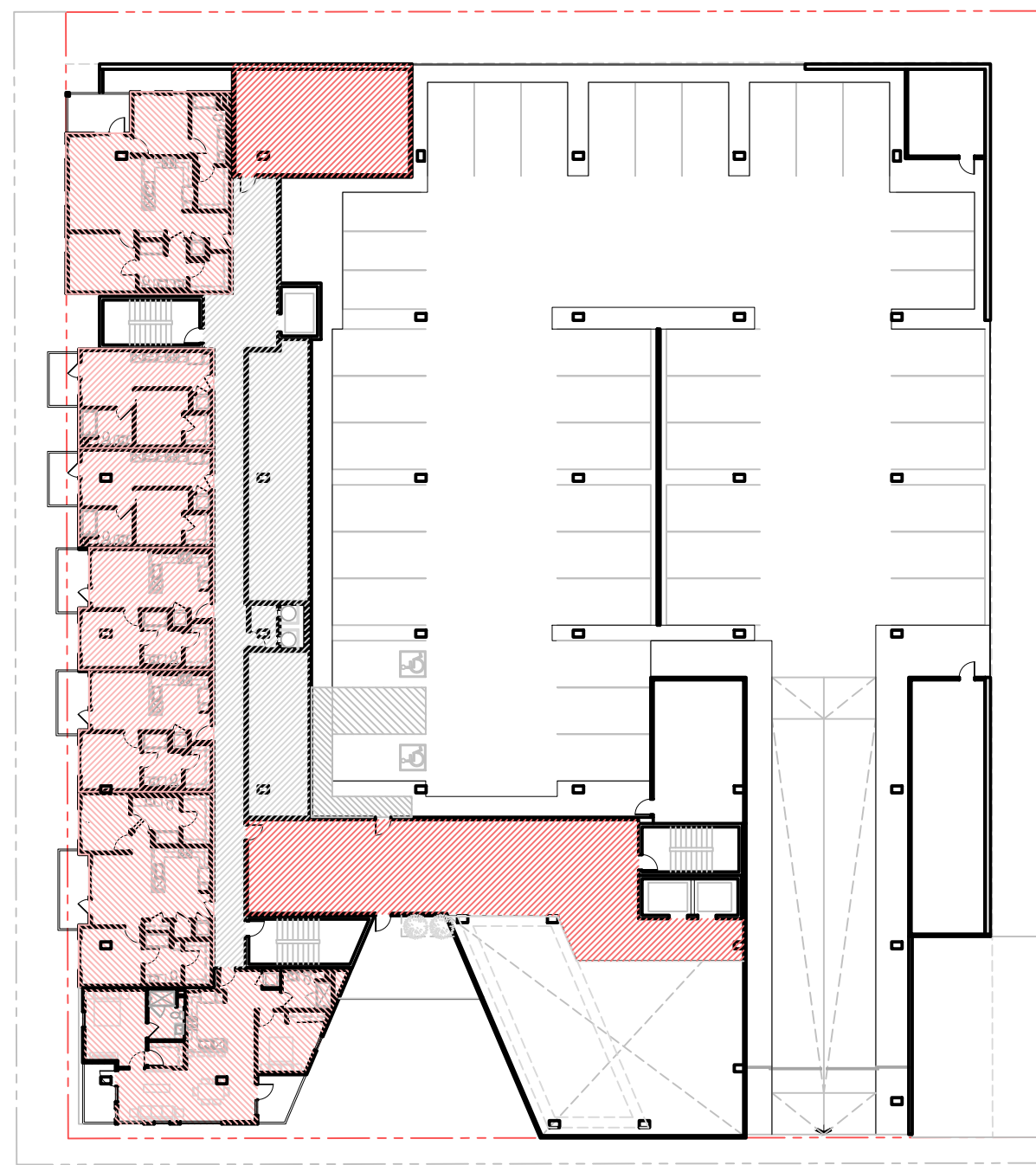

LEVEL 02

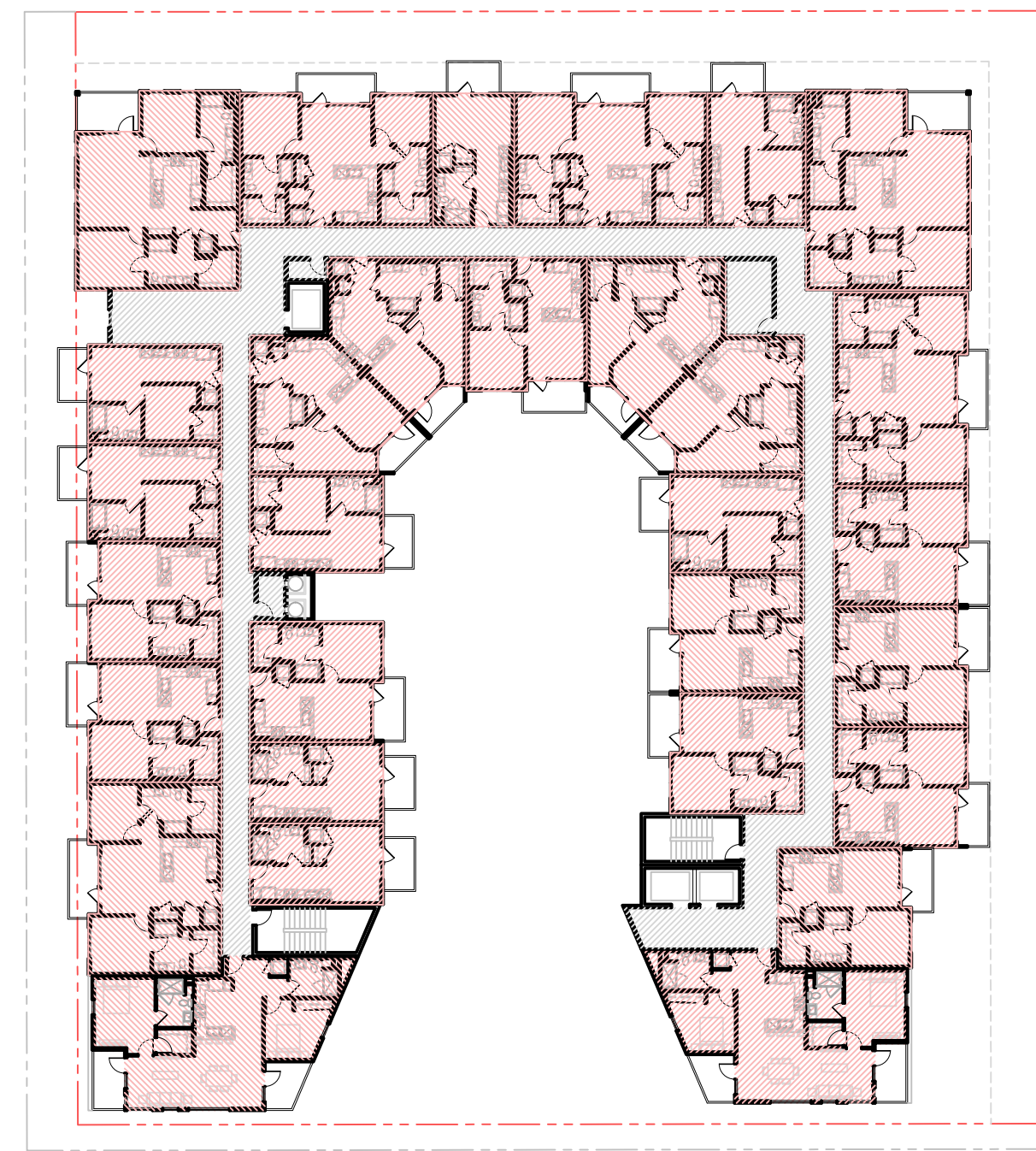

LEVEL 04-06

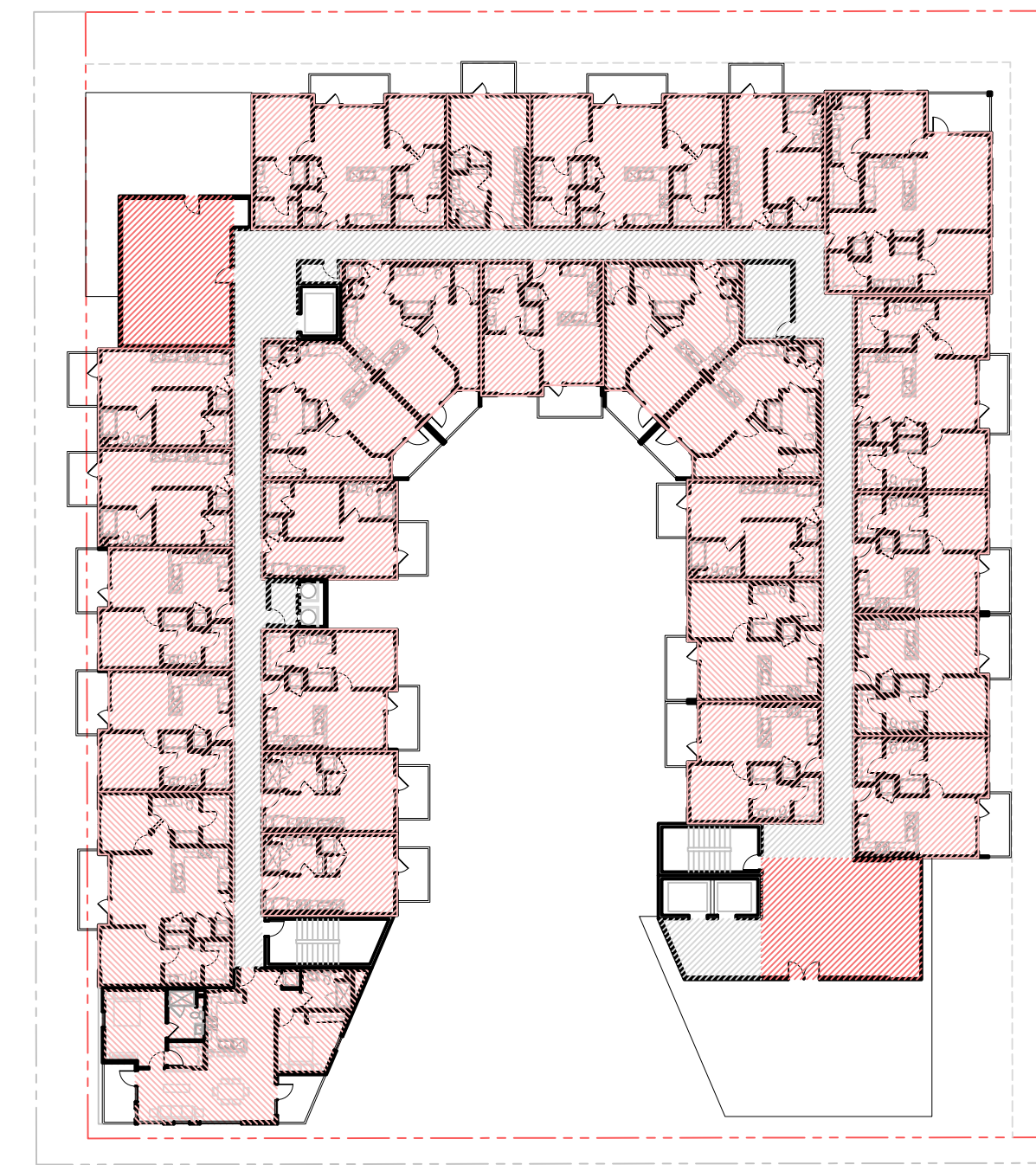

LEVEL 07

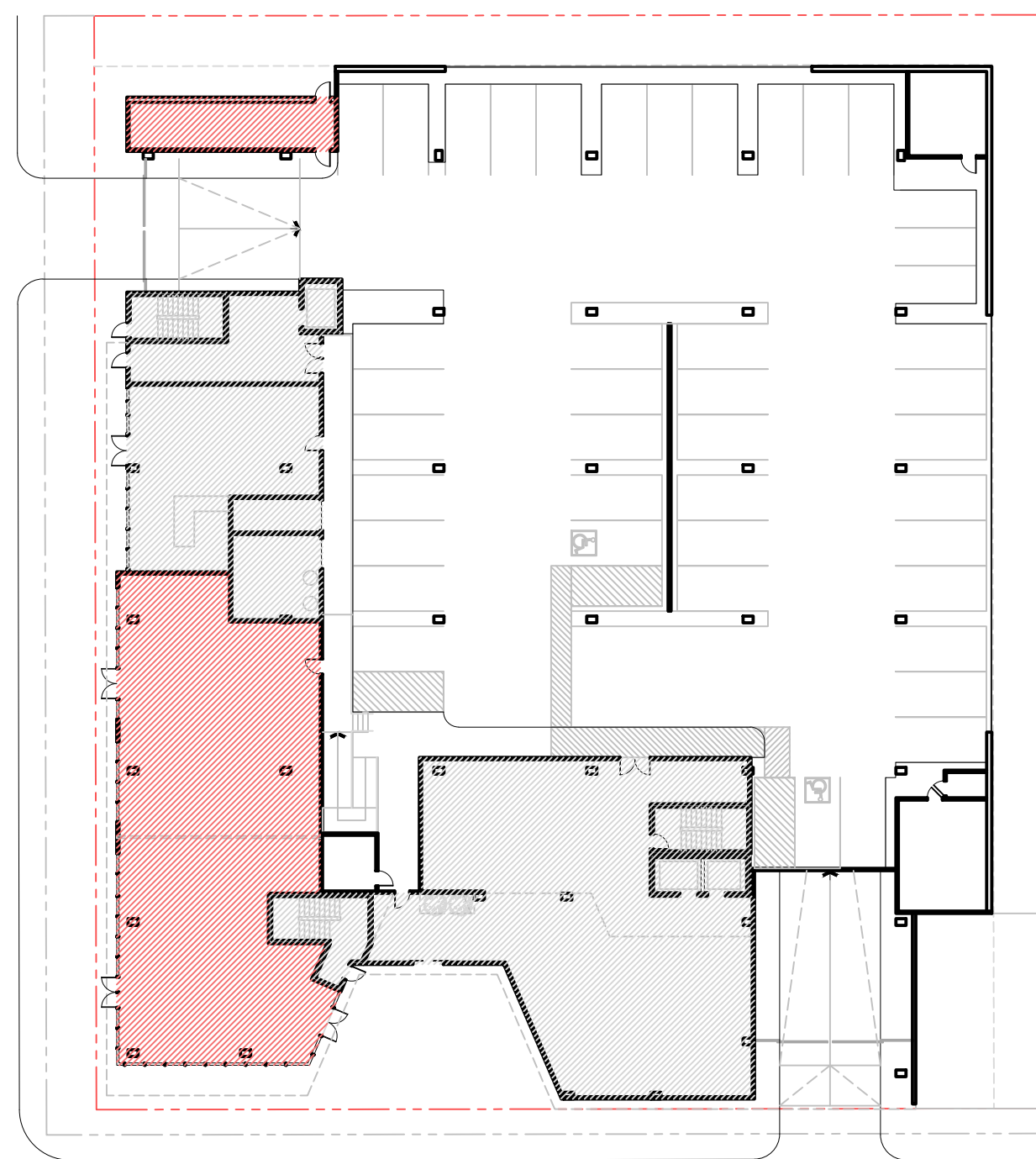

LEVEL 01

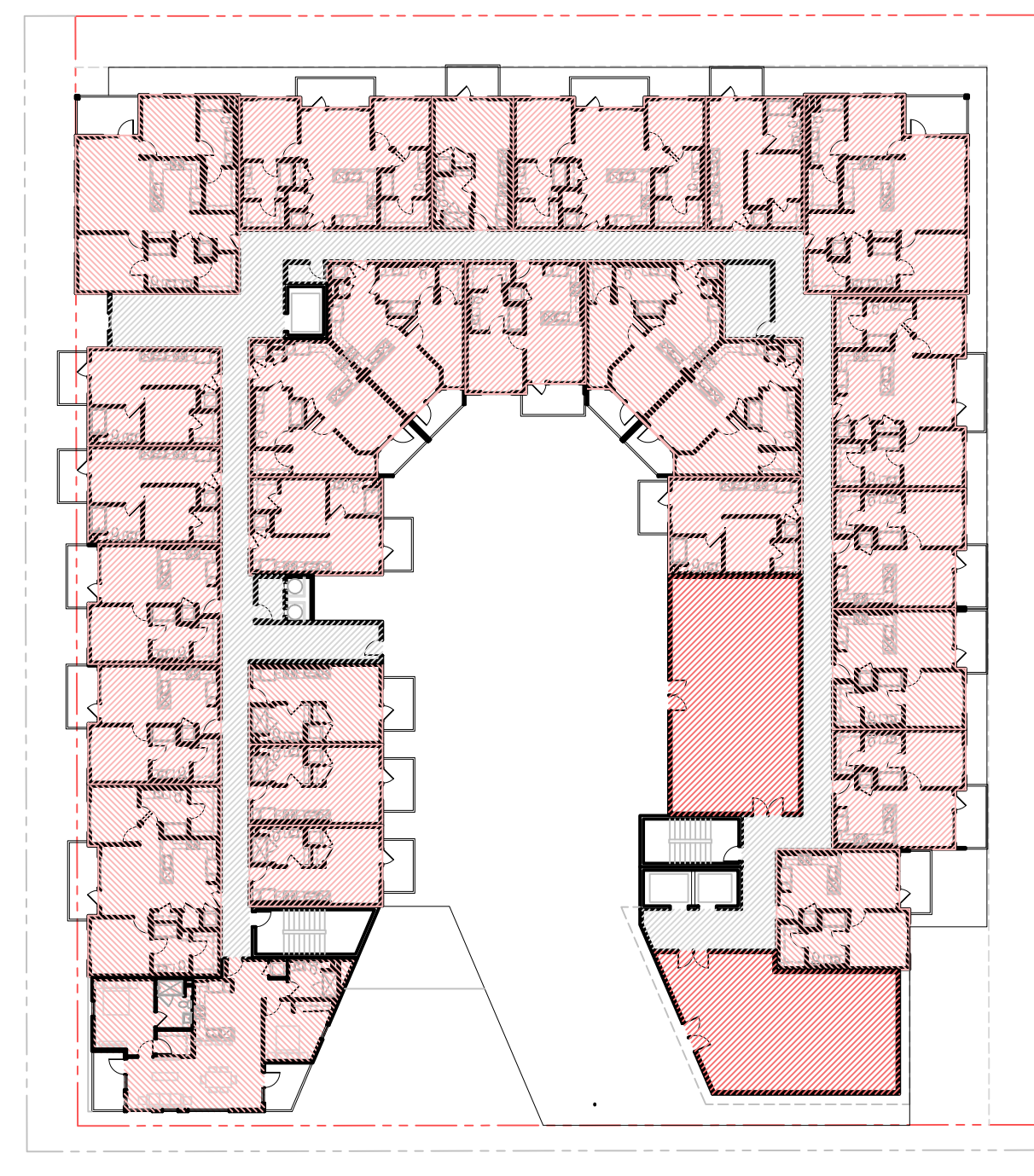

LEVEL 03

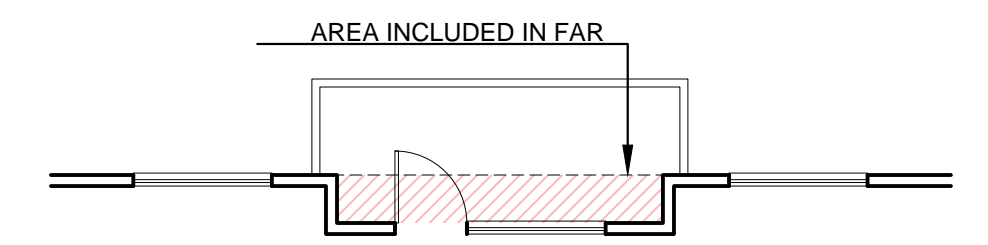

**PARTIAL BALCONY AREAS COVERED ON 3 SIDES ARE INCLUDED IN THE FAR CALCULATION

COLOR LEGEND

- 1. AMENITY SPACE
- 2. RESIDENTIAL
- 3. COMMON SPACE

FAR TABLE		
LOT SIZE: 40,786 SQFT		
	FAR	SQFT PERMITTED
C2-1D ZONE	.5 :1	20,393 SF
PROPOSED	3.40 :1	138,765 SF

FLOOR AREA SUMMARY								
FLOOR / LEVEL	APARTMENT UNITS	RESIDENTIAL UNIT AREA	COMMON AREAS / CIRCULATION	AMENITY/ LOBBY / RETAIL AREA	BALC. AREA (INCL. IN FAR)	TOTAL FLOOR AREA	GARAGE / MECH AREA	GROSS BUILDING AREA
Level 1	0 UNITS	0 SF	1,380 SF	9,040 SF	0 SF	10,420 SF	22,262 SF	32,682 SF
Level 2	7 UNITS	5,389 SF	2,135 SF	2,140 SF	72 SF	9,736 SF	20,585 SF	30,321 SF
Level 3	27 UNITS	18,091 SF	3,308 SF	2,320 SF	466 SF	24,185 SF	0 SF	24,185 SF
Level 4	30 UNITS	20,564 SF	3,088 SF	0 SF	533 SF	24,185 SF	0 SF	24,185 SF
Level 5	30 UNITS	20,564 SF	3,088 SF	0 SF	533 SF	24,185 SF	0 SF	24,185 SF
Level 6	30 UNITS	20,564 SF	3,088 SF	0 SF	533 SF	24,185 SF	0 SF	24,185 SF
Level 7	27 UNITS	17,704 SF	2,800 SF	1,365 SF	0 SF	21,869 SF	0 SF	21,869 SF
Total	151 UNITS	102,876 SF	18,887 SF	14,865 SF	2,137 SF	138,765 SF	42,847 SF	181,612 SF



Architecture + Planning
888.456.5849
ktgy.com

Grubb Properties
4601 Park Road, Suite 450
Charlotte, NC 28209

1200 VINE STREET
LOS ANGELES, CA # 2021-1034

CONCEPTUAL DESIGN
APRIL 11, 2023

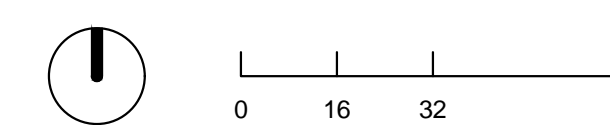

FAR EXHIBIT

A1-3

BUILDING AREA

LEVEL 1 (GRADE)

- RETAIL:	3,690 SF
- AMENITY:	5,350 SF
- CIRCULATION:	960 SF
- SERVICE:	1,282 SF
- PARKING:	21,400 SF

TOTAL: 32,682 SF

LEVEL 2

- RESIDENTIAL:	5,389 SF
- AMENITY:	2,140 SF
- CIRCULATION:	1,130 SF
- SERVICE:	2,447 SF
- PARKING:	19,143 SF

TOTAL: 30,321 SF

LEVEL 3 (PODIUM)

- RESIDENTIAL:	18,091 SF
- AMENITY:	2,320 SF
- CIRCULATION:	3,096 SF
- SERVICE:	212 SF

TOTAL: 24,185 SF

LEVEL 4-6

- RESIDENTIAL:	20,564 SF
- CIRCULATION:	2,876 SF
- SERVICE:	212 SF

TOTAL: 24,185 SF

LEVEL 7

- RESIDENTIAL:	17,704 SF
- AMENITY:	1,365 SF
- CIRCULATION:	2,588 SF
- SERVICE:	212 SF

TOTAL: 24,185 SF

BUILDING AREA TOTAL: 181,612 SF

COLOR LEGEND

- 1. RESIDENTIAL AREA
- 2. RETAIL AREA
- 3. AMENITY AREA
- 4. CIRCULATION & COMMON AREAS
- 5. PARKING AREA
- 6. SERVICE AREA

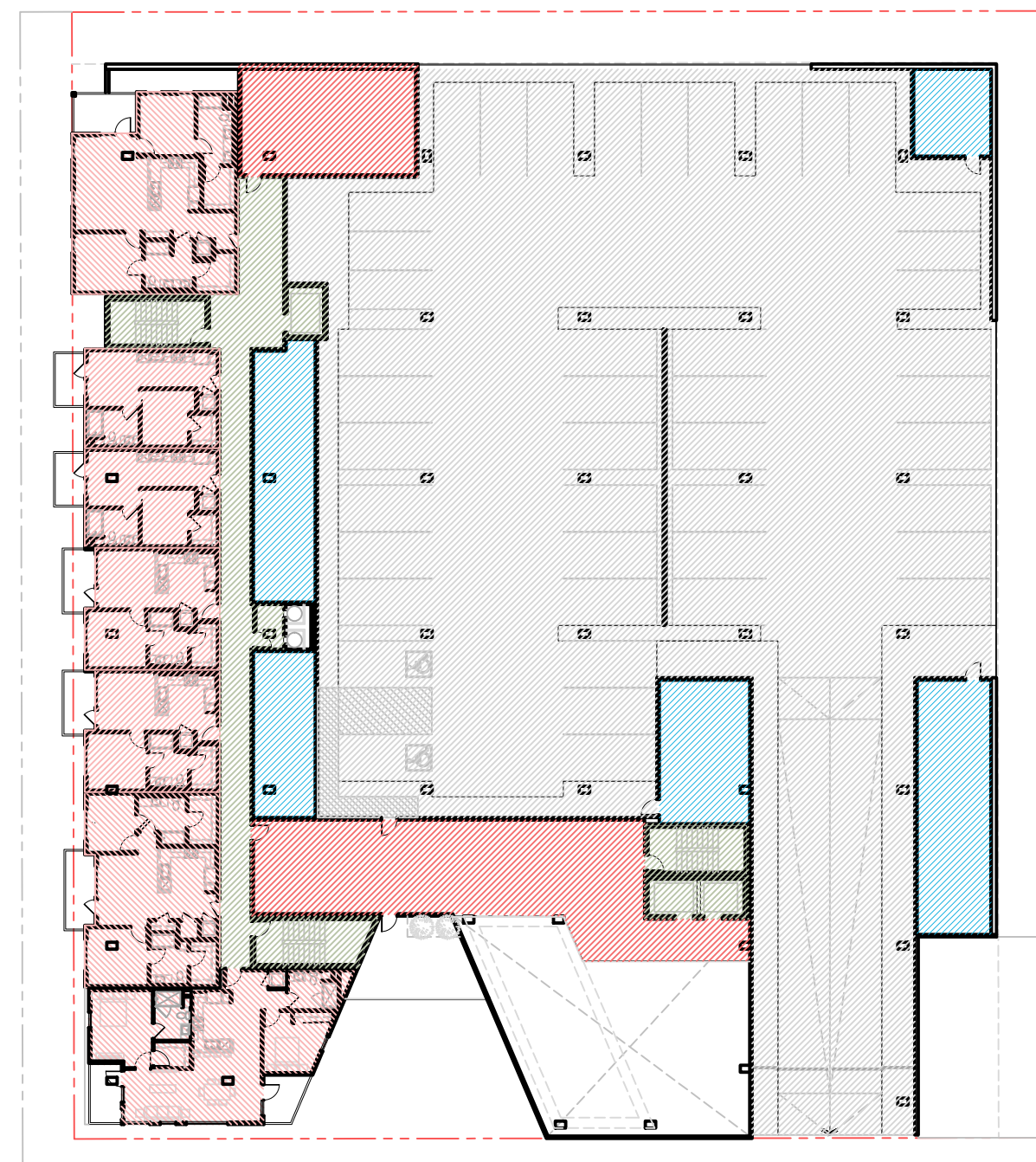

LEVEL 02

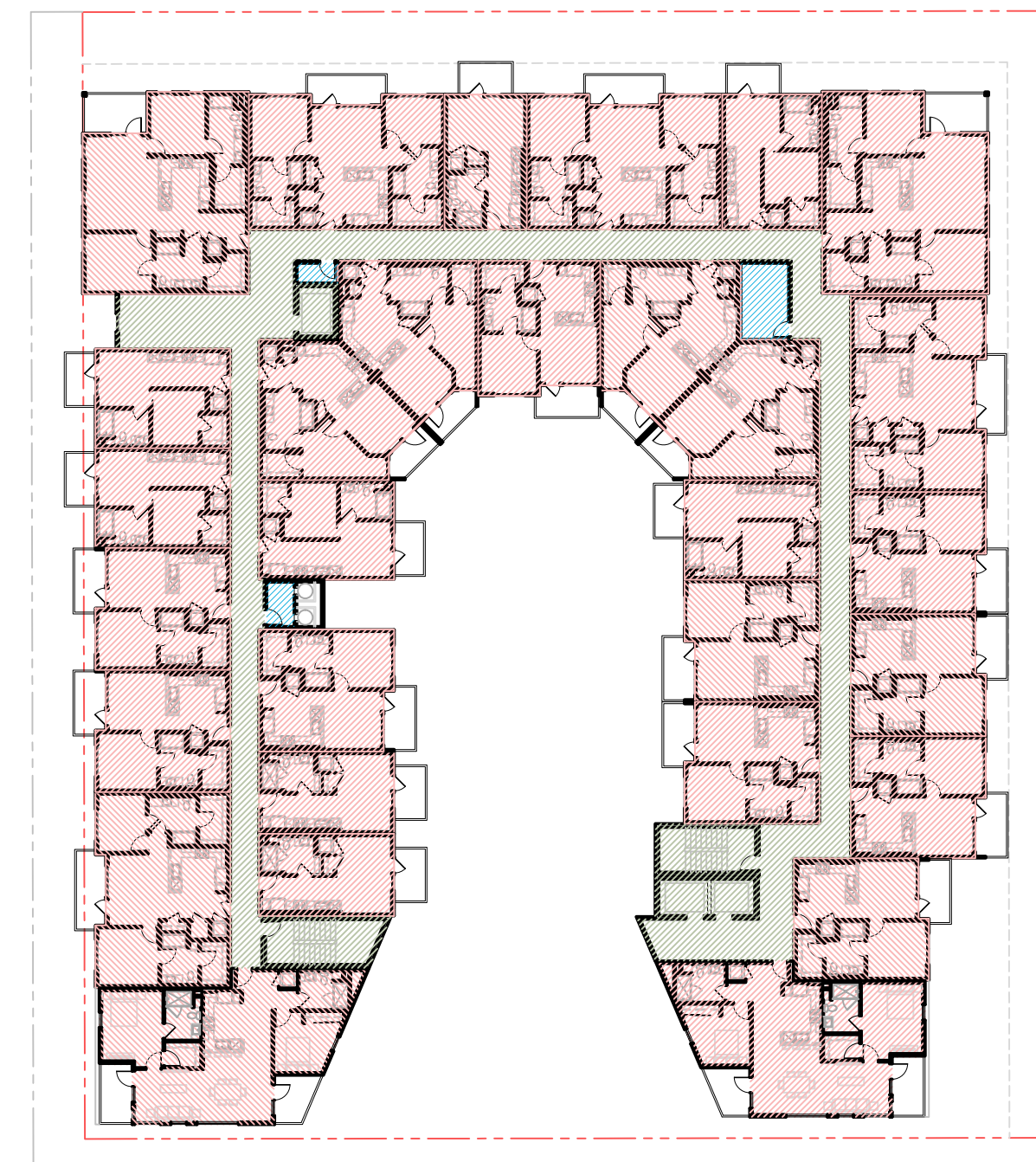

LEVEL 04-06

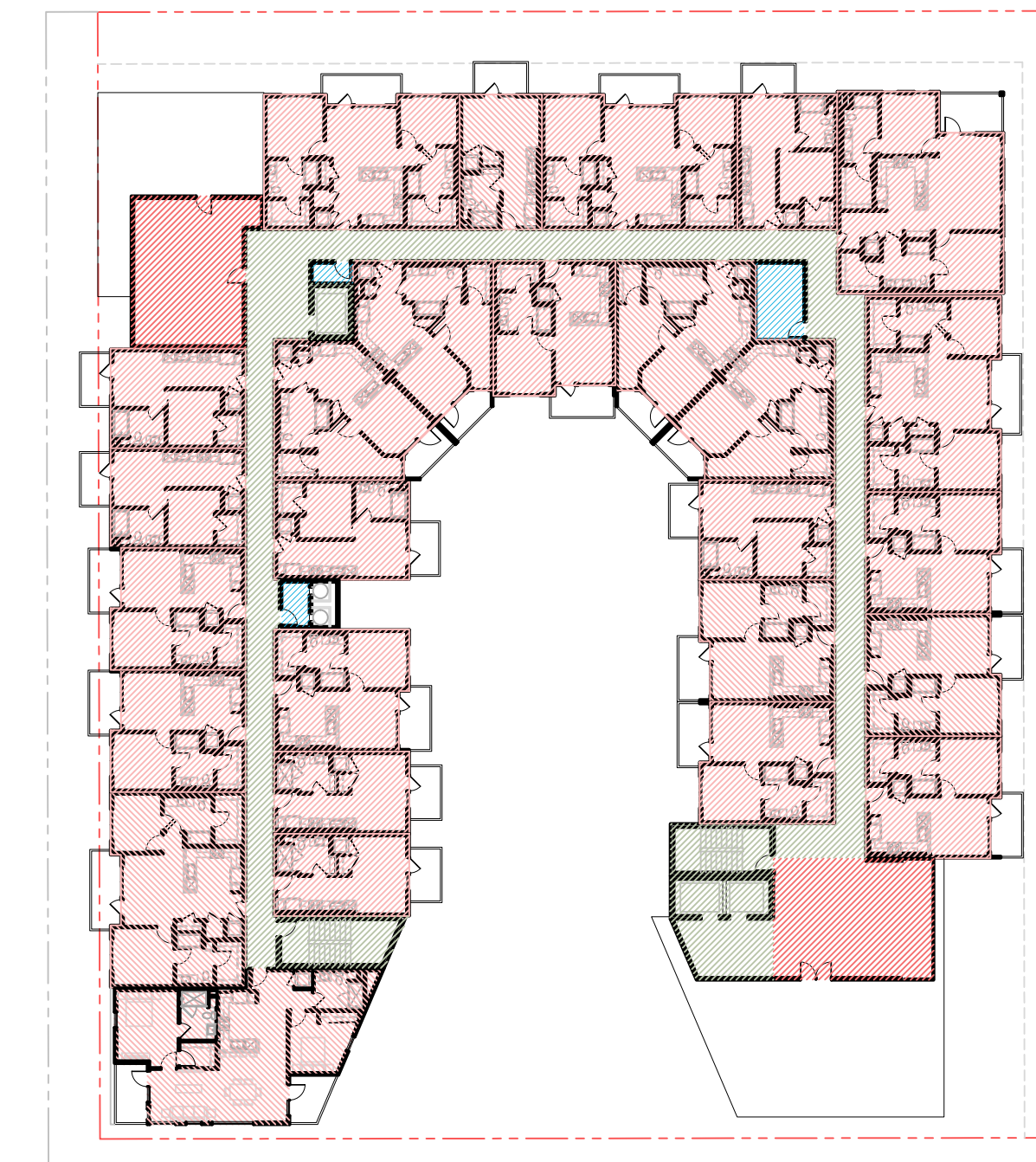

LEVEL 07



LEVEL 01

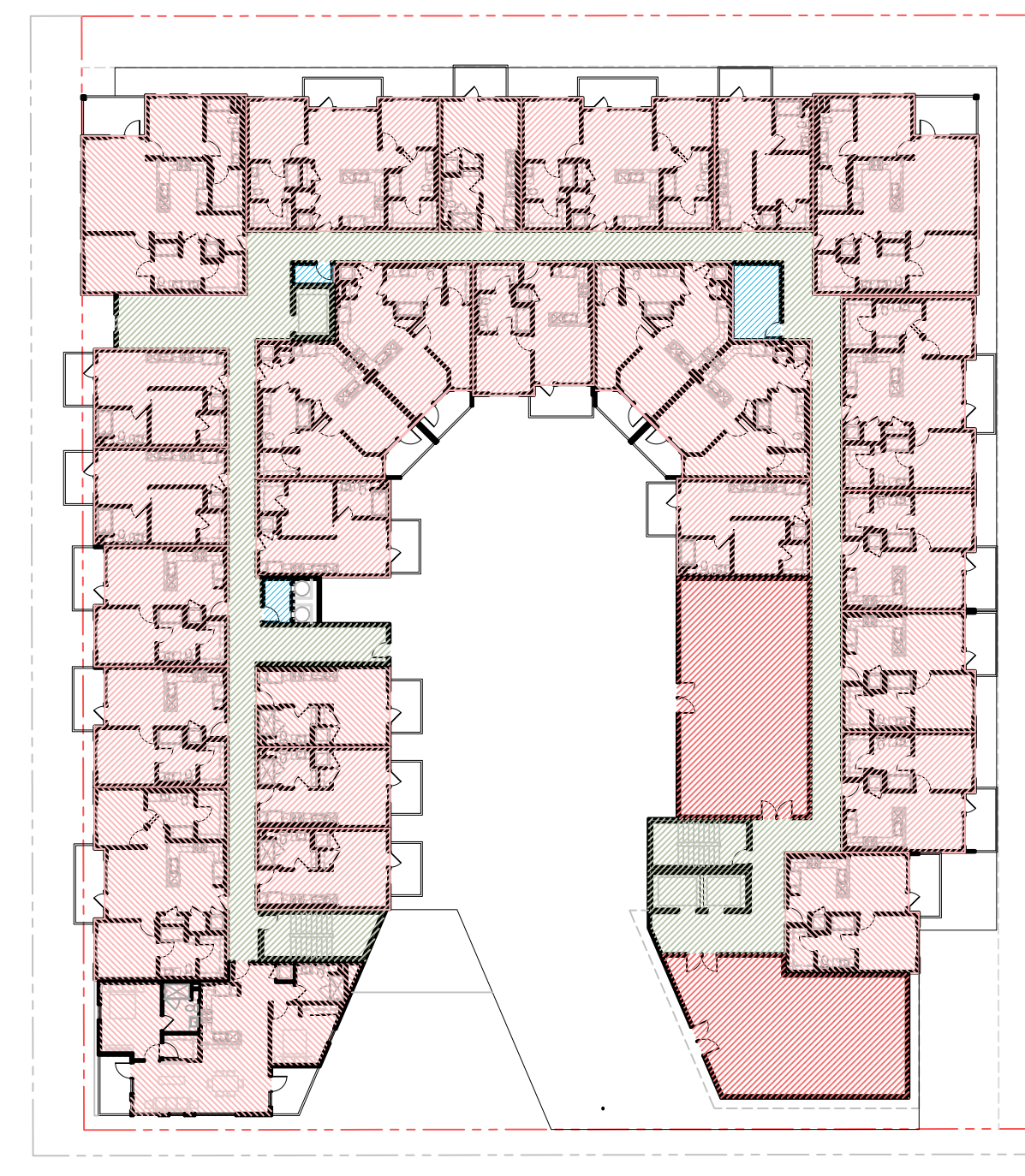

LEVEL 03

BUILDING AREA

RESIDENTIAL AREA	177,727 SF
COMMERCIAL AREA	3,885 SF

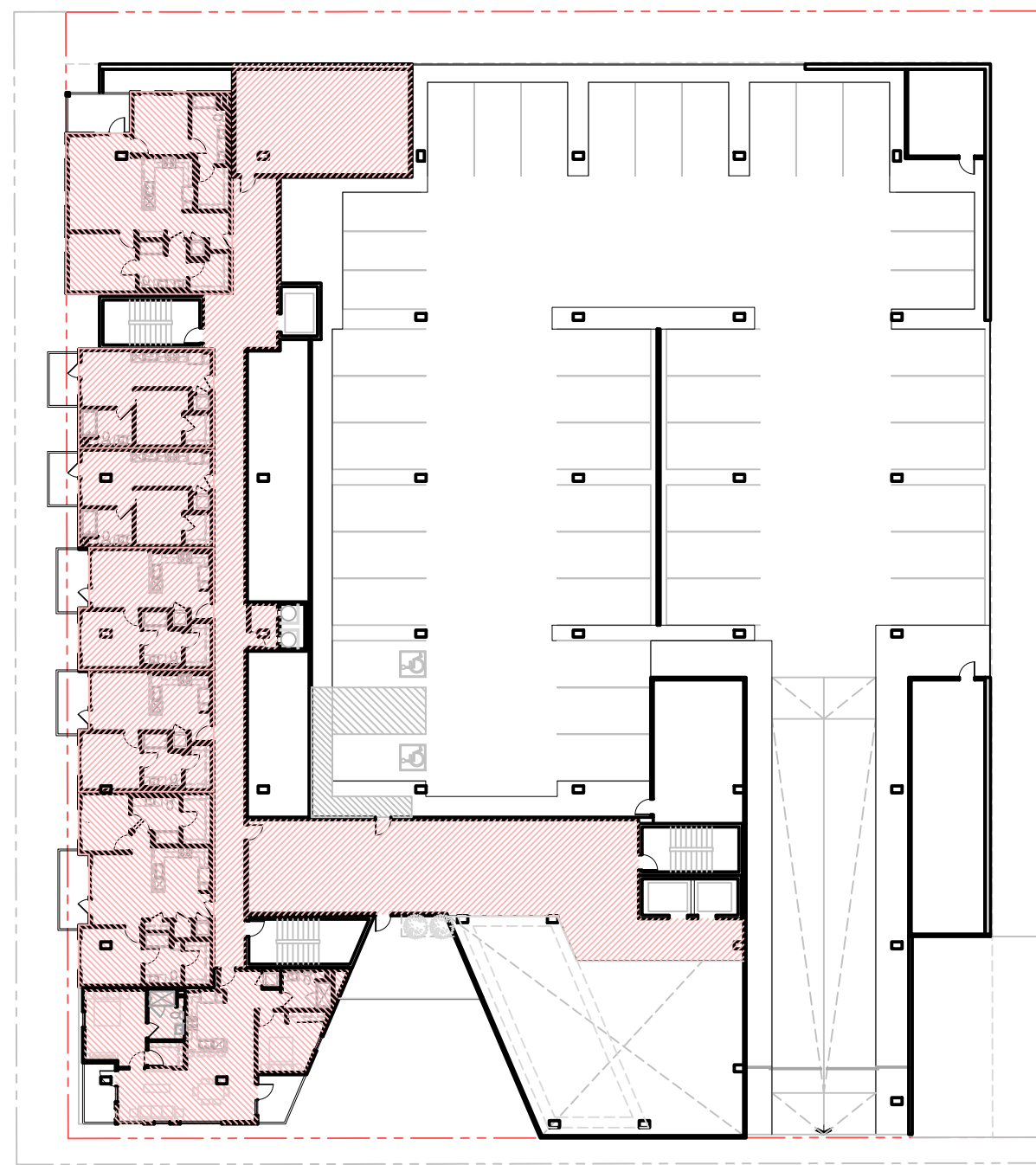

LEVEL 02

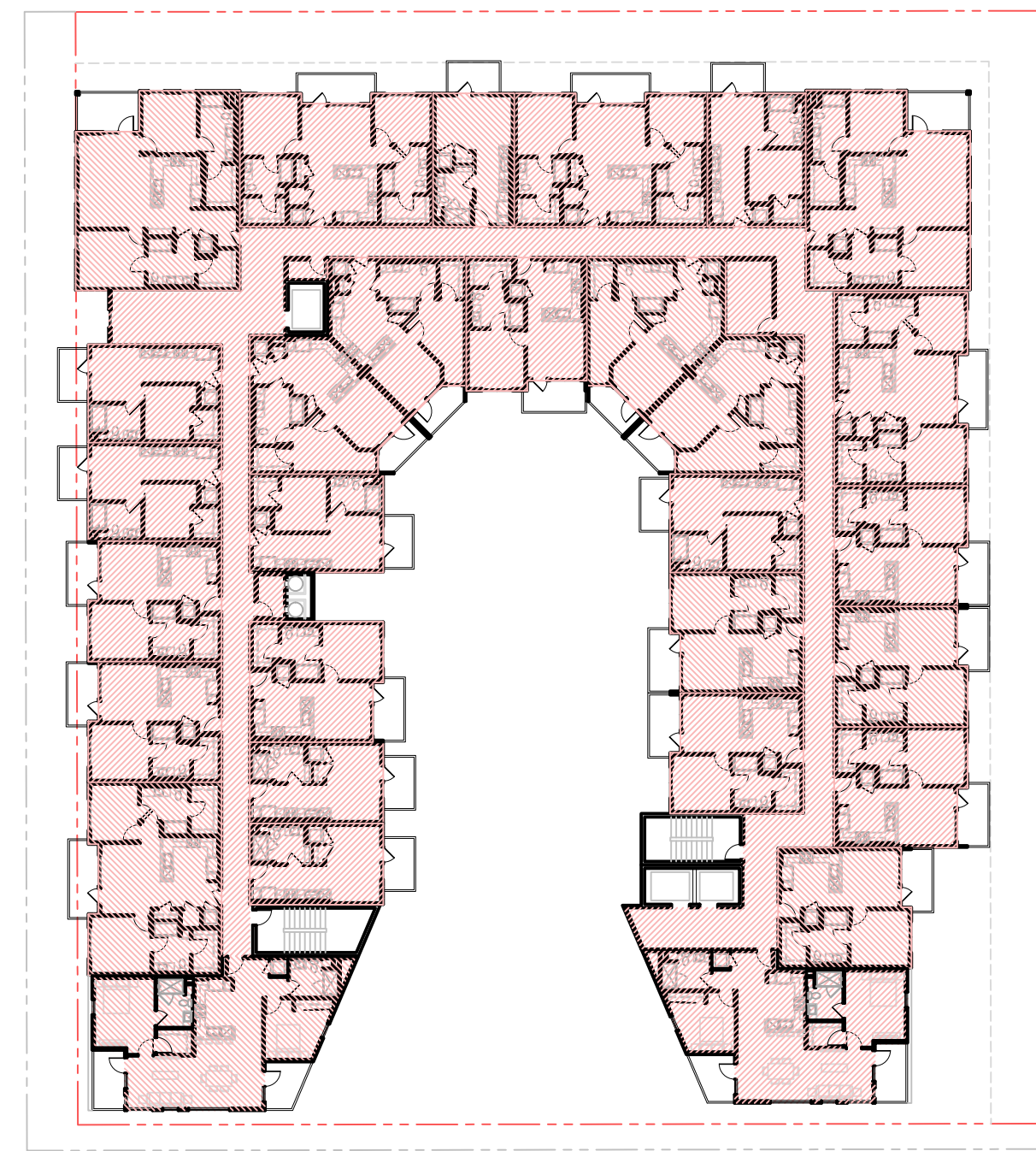

LEVEL 04-06

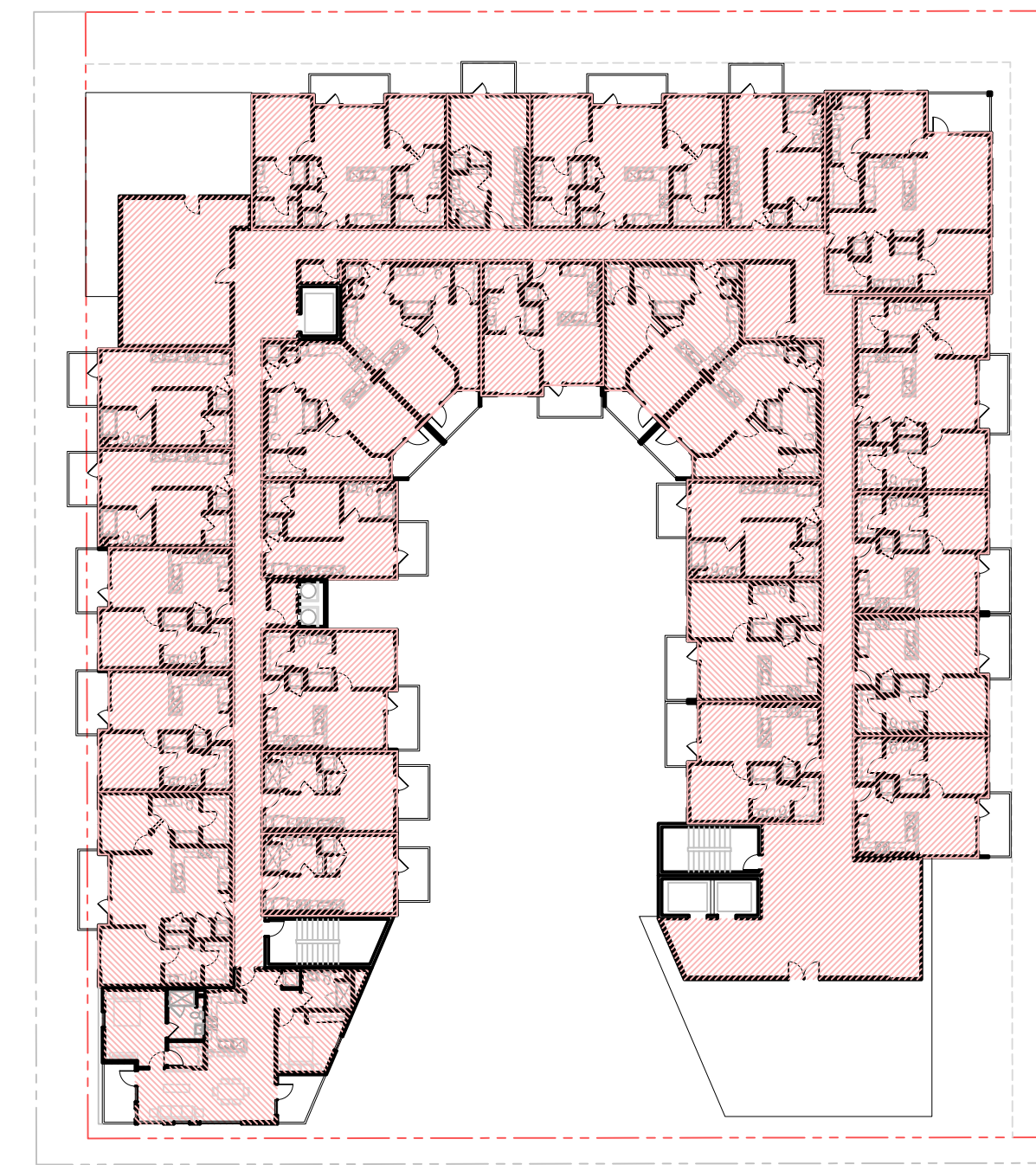

LEVEL 07

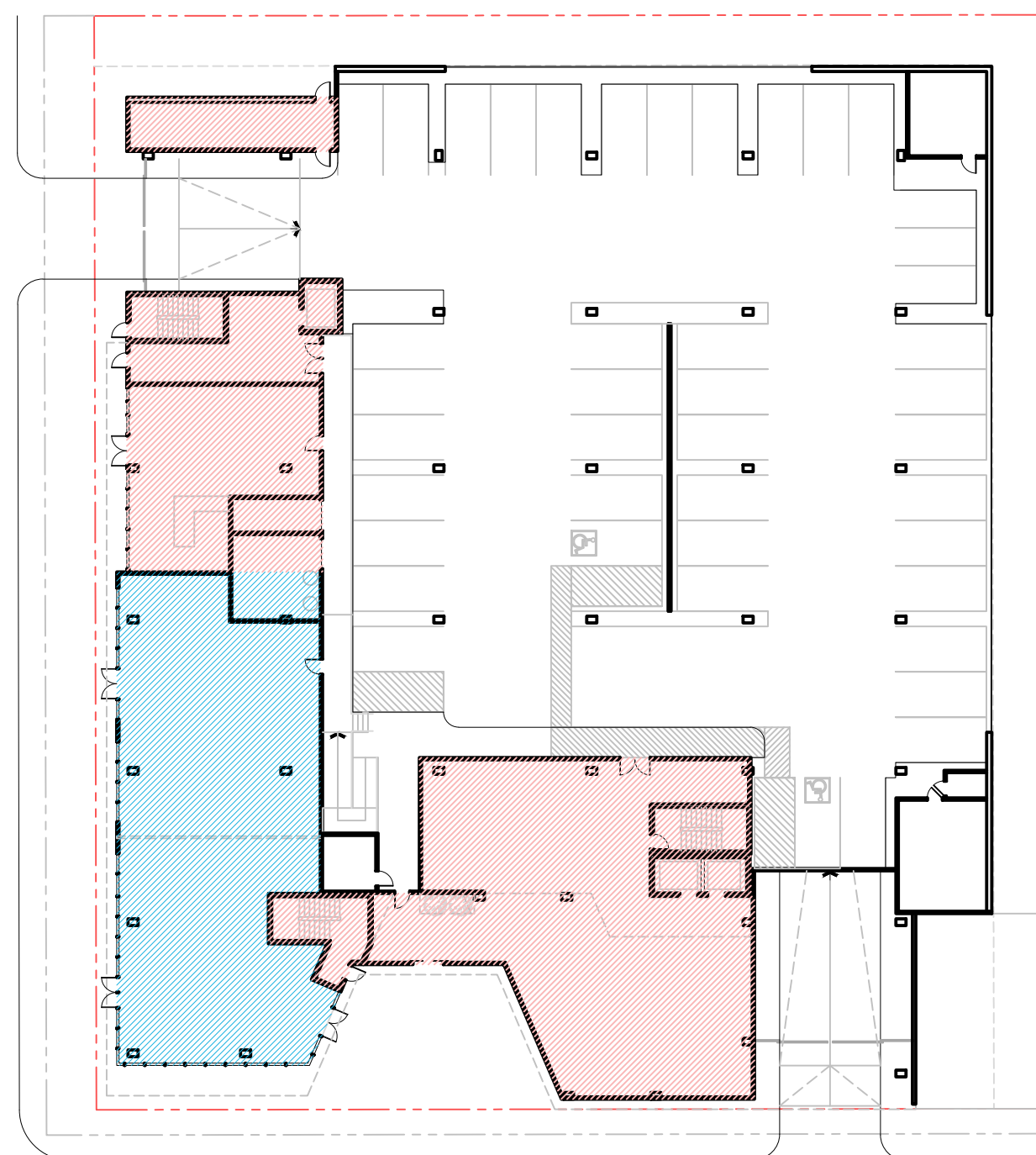

LEVEL 01

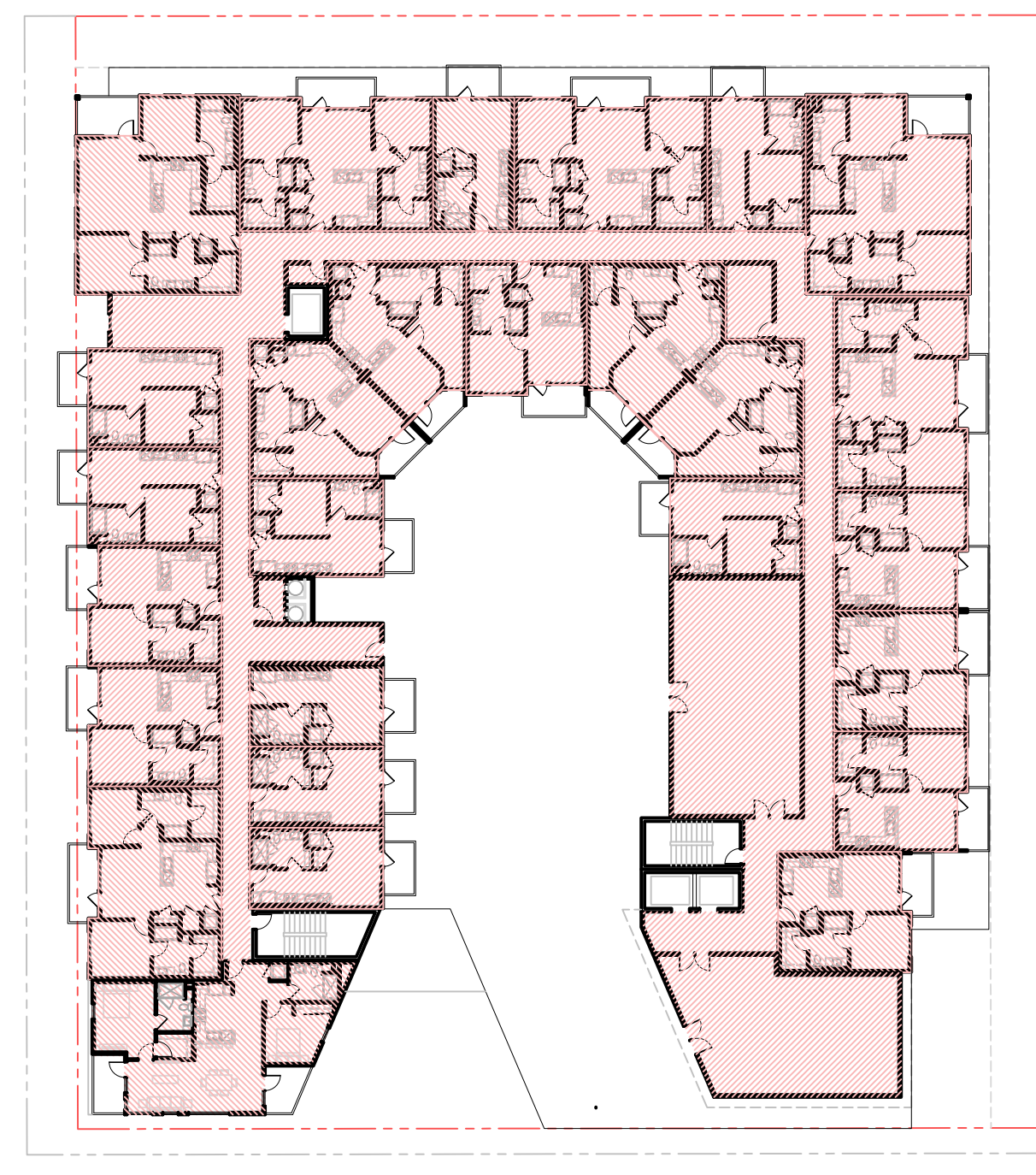

LEVEL 03

COLOR LEGEND

- 1. RESIDENTIAL AREA
- 2. COMMERCIAL AREA



Architecture + Planning
888.456.5849
ktgy.com

Grubb Properties
4601 Park Road, Suite 450
Charlotte, NC 28209

1200 VINE STREET
LOS ANGELES, CA # 2021-1034

CONCEPTUAL DESIGN
APRIL 11, 2023

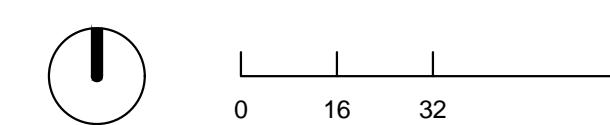

LAUSD FEE BREAKDOWN

A1-5

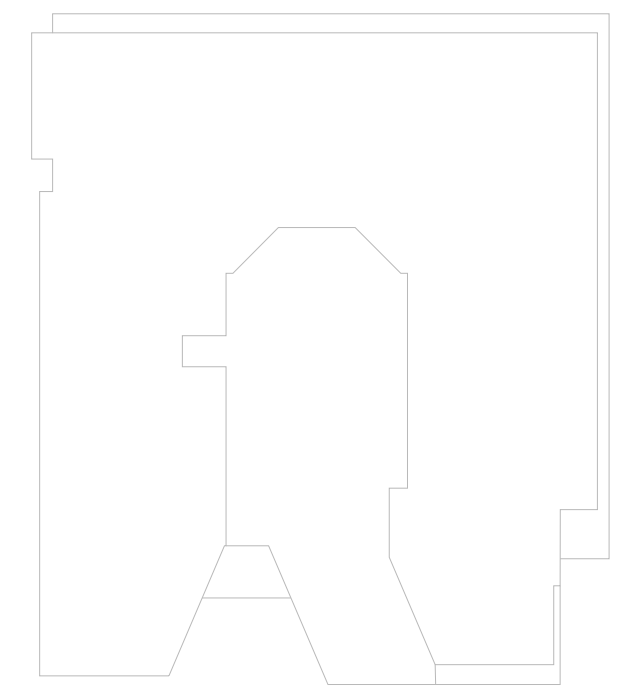

A

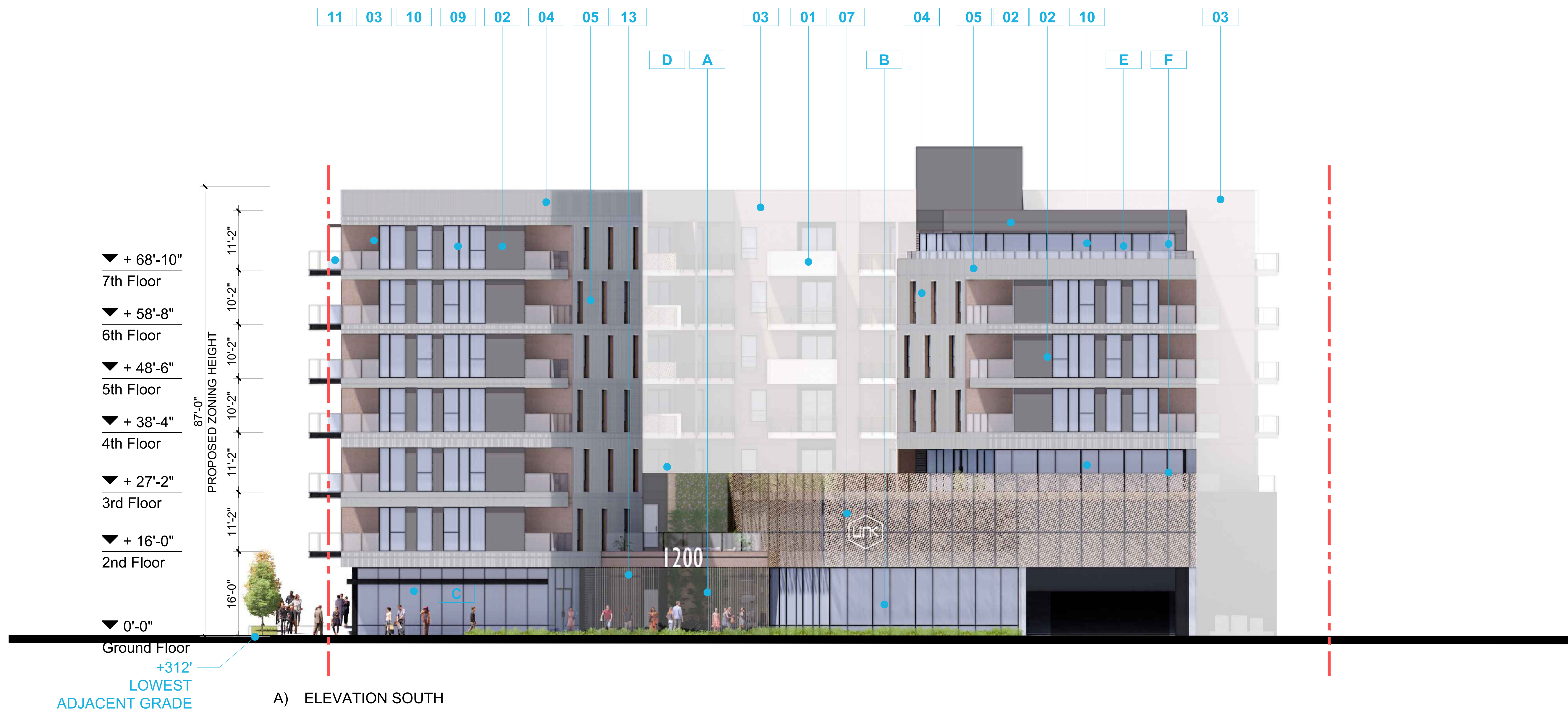

A) ELEVATION SOUTH

SPACE CALLOUT LEGEND

- A MAIN ENTRY
- B LOBBY
- C RETAIL
- D COURTYARD
- E ROOF DECK
- F INDOOR AMENITY

MATERIAL CALLOUT LEGEND

- 01 STUCCO BODY 01
- 02 STUCCO BODY 02
- 03 STUCCO BODY 03
- 04 FIBER-CEMENT PANEL 01
- 05 FIBER-CEMENT PANEL 02
- 07 BOK MODERN PERF. METAL PANEL
- 08 NATURAL STONE TILE
- 09 DARK VINYL WINDOWS
- 10 DARK BRONZE STOREFRONT
- 11 GLASS GUARDRAILS
- 12 PERF. METAL GUARDRAILS / SCREEN
- 13 ALUMINUM LOUVRES



Architecture + Planning
888.456.5849
ktgy.com

Grubb Properties
4601 Park Road, Suite 450
Charlotte, NC 28209

1200 VINE STREET
LOS ANGELES, CA # 2021-1034

CONCEPTUAL DESIGN
APRIL 11, 2023

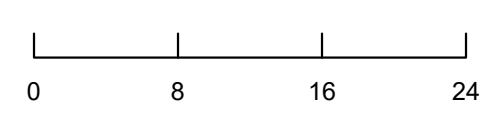

BUILDING ELEVATIONS
SOUTH

A2-0

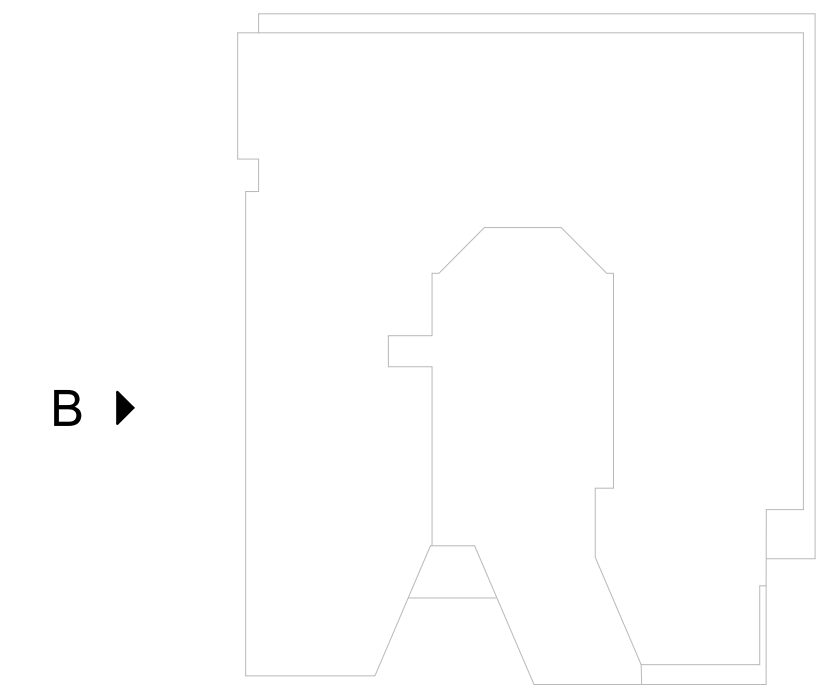

SPACE CALLOUT LEGEND

- A MAIN ENTRY
- B LOBBY
- C RETAIL
- D COURTYARD
- E ROOF DECK
- F INDOOR AMENITY

MATERIAL CALLOUT LEGEND

- 01 STUCCO BODY 01
- 02 STUCCO BODY 02
- 03 STUCCO BODY 03
- 04 FIBER-CEMENT PANEL 01
- 05 FIBER-CEMENT PANEL 02
- 07 BOK MODERN PERF. METAL PANEL
- 08 NATURAL STONE TILE
- 09 DARK VINYL WINDOWS
- 10 DARK BRONZE STOREFRONT
- 11 GLASS GUARDRAILS
- 12 PERF. METAL GUARDRAILS / SCREEN
- 13 ALUMINUM LOUVRES



Architecture + Planning
888.456.5849
ktgy.com

Grubb Properties
4601 Park Road, Suite 450
Charlotte, NC 28209

1200 VINE STREET
LOS ANGELES, CA # 2021-1034

CONCEPTUAL DESIGN
APRIL 11, 2023

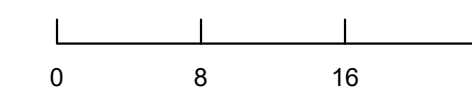

BUILDING ELEVATIONS
WEST

A2-1

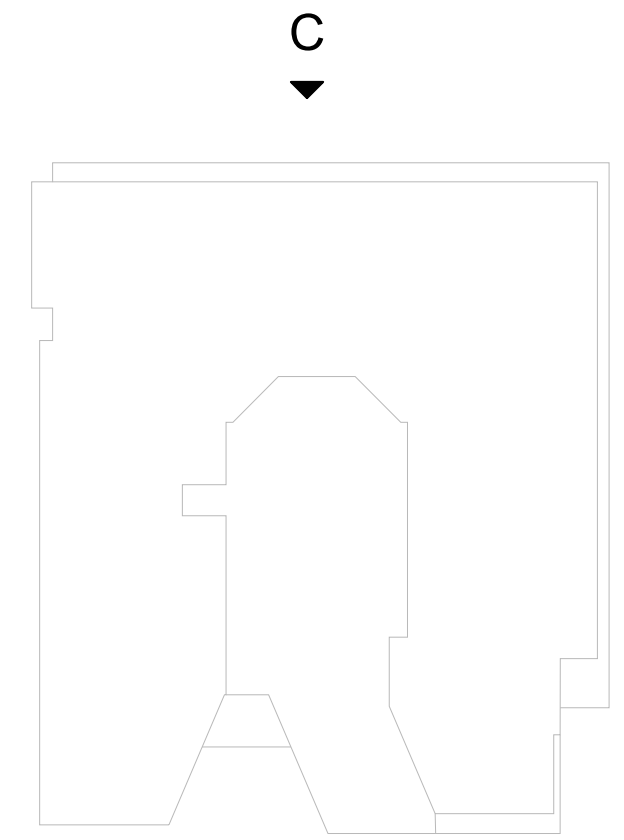

SPACE CALLOUT LEGEND

- A MAIN ENTRY
- B LOBBY
- C RETAIL
- D COURTYARD
- E ROOF DECK
- F INDOOR AMENITY

MATERIAL CALLOUT LEGEND

- 01 STUCCO BODY 01
- 02 STUCCO BODY 02
- 03 STUCCO BODY 03
- 04 FIBER-CEMENT PANEL 01
- 05 FIBER-CEMENT PANEL 02
- 07 BOK MODERN PERF. METAL PANEL
- 08 NATURAL STONE TILE
- 09 DARK VINYL WINDOWS
- 10 DARK BRONZE STOREFRONT
- 11 GLASS GUARDRAILS
- 12 PERF. METAL GUARDRAILS / SCREEN
- 13 ALUMINUM LOUVRES



Architecture + Planning
888.456.5849
ktgy.com

Grubb Properties
4601 Park Road, Suite 450
Charlotte, NC 28209

1200 VINE STREET
LOS ANGELES, CA # 2021-1034

CONCEPTUAL DESIGN
APRIL 11, 2023

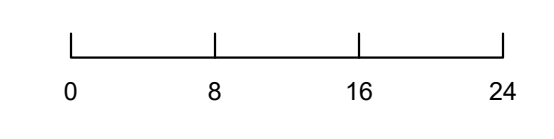

BUILDING ELEVATIONS
NORTH

A2-2

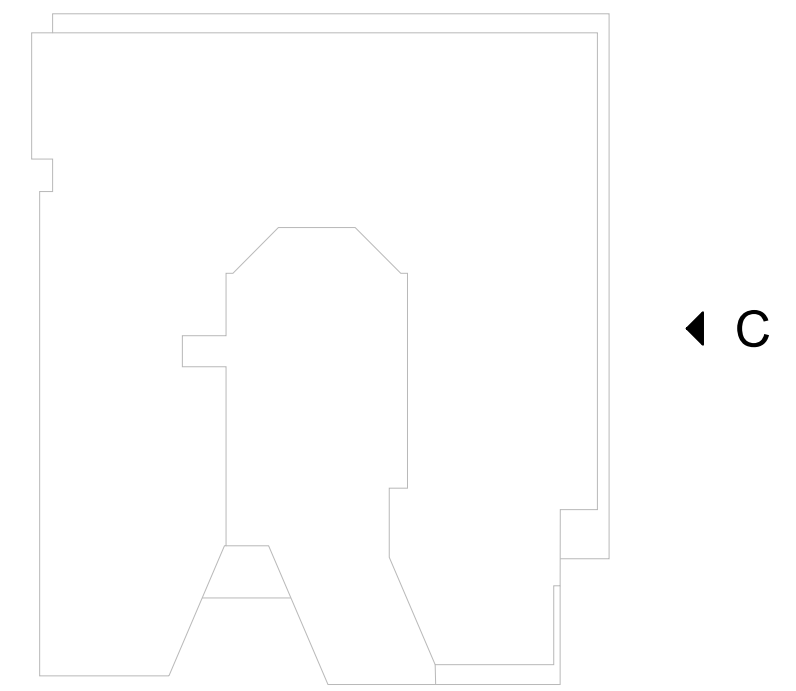

D) ELEVATION EAST

SPACE CALLOUT LEGEND

- A MAIN ENTRY
- B LOBBY
- C RETAIL
- D COURTYARD
- E ROOF DECK
- F INDOOR AMENITY

MATERIAL CALLOUT LEGEND

- 01 STUCCO BODY 01
- 02 STUCCO BODY 02
- 03 STUCCO BODY 03
- 04 FIBER-CEMENT PANEL 01
- 05 FIBER-CEMENT PANEL 02
- 07 BOK MODERN PERF. METAL PANEL
- 08 NATURAL STONE TILE
- 09 DARK VINYL WINDOWS
- 10 DARK BRONZE STOREFRONT
- 11 GLASS GUARDRAILS
- 12 PERF. METAL GUARDRAILS / SCREEN
- 13 ALUMINUM LOUVRES



Architecture + Planning
888.456.5849
ktgy.com

Grubb Properties
4601 Park Road, Suite 450
Charlotte, NC 28209

1200 VINE STREET
LOS ANGELES, CA # 2021-1034

CONCEPTUAL DESIGN
APRIL 11, 2023

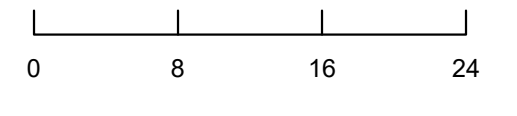

BUILDING ELEVATIONS
EAST

A2-3

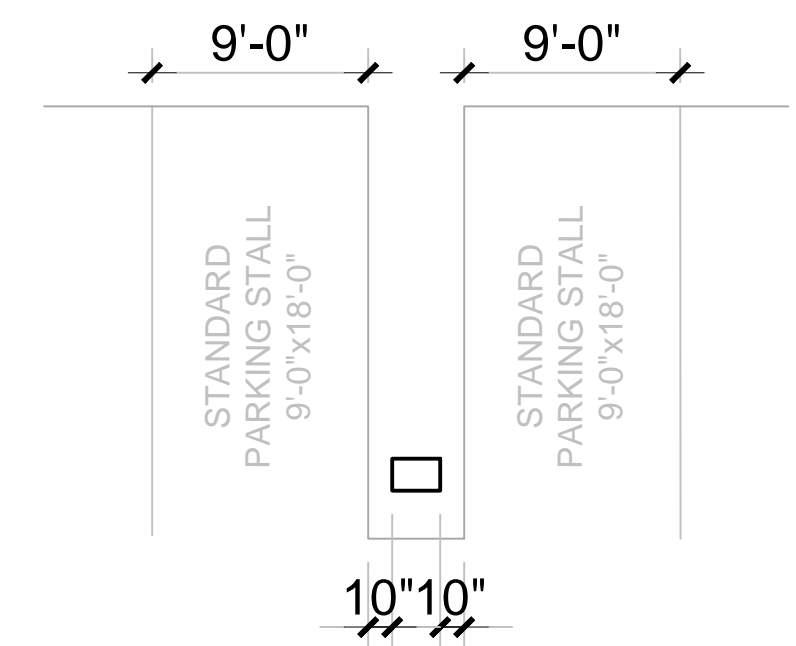

TYPICAL 10" CLEARANCE FROM PARKING STALL TO STRUCTURAL COLUMN

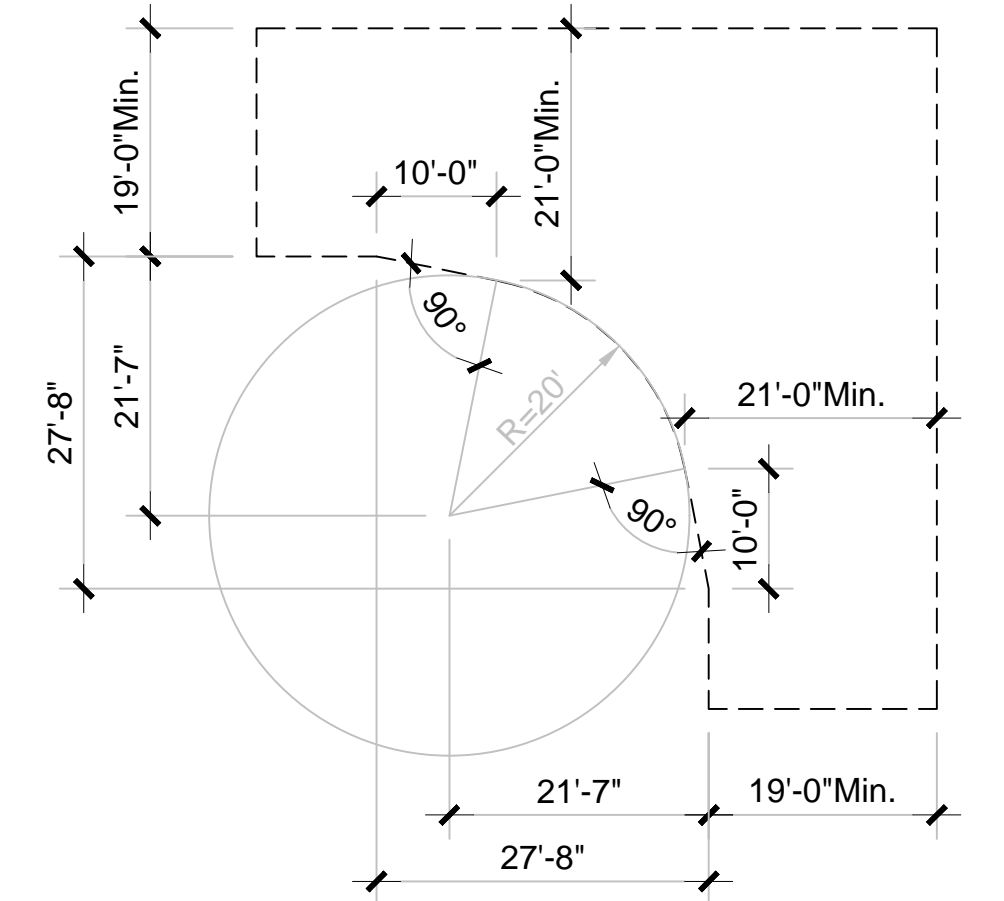

2-WAY TURNING RADIUS

PARKING PROVIDED								
RESIDENTIAL								
PARKING STALL TYPE	COMPACT	STANDARD	EVSE	EV CAPABLE	EV READY	EV READY ADA	ADA	TOTAL
1st FLOOR	3	16	2	5	9	1	0	36
COMMERCIAL								
PARKING STALL TYPE	COMPACT	STANDARD	EVSE	EV CAPABLE	EV READY	EV READY ADA	ADA	TOTAL
1st FLOOR	0	3	1	1	1	1	0	7



Architecture + Planning
888.456.5849
ktgy.com

Grubb Properties
4601 Park Road, Suite 450
Charlotte, NC 28209

1200 VINE STREET
LOS ANGELES, CA # 2021-1034

CONCEPTUAL DESIGN
APRIL 11, 2023



BUILDING PLAN
LEVEL 1

A3-0

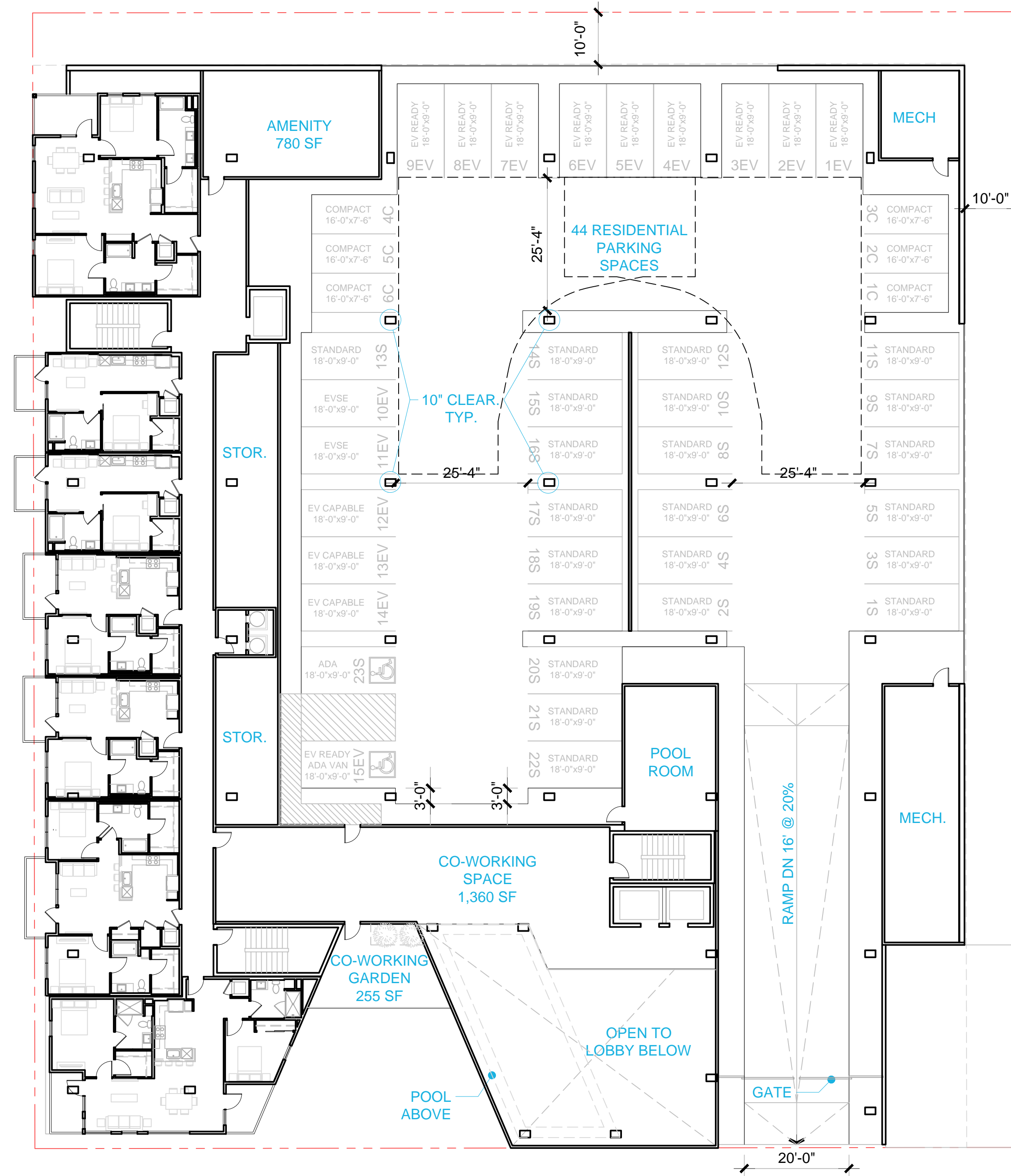

VINE STREET

LEXINGTON AVENUE

PARKING PROVIDED									
RESIDENTIAL									
PARKING STALL TYPE	COMPACT	STANDARD	EVSE	EV CAPABLE	EV READY	EV READY ADA	ADA	ADA	TOTAL
2nd FLOOR	6	22	2	3	9	1	1		44
COMMERCIAL									
PARKING STALL TYPE	COMPACT	STANDARD	EVSE	EV CAPABLE	EV READY	EV READY ADA	ADA	ADA	TOTAL
2nd FLOOR	0	0	0	0	0	0	0	0	0



Architecture + Planning
888.456.5849
ktgy.com

Grubb Properties
4601 Park Road, Suite 450
Charlotte, NC 28209

1200 VINE STREET
LOS ANGELES, CA # 2021-1034

CONCEPTUAL DESIGN
APRIL 11, 2023

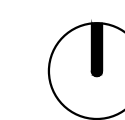

0 8 16 32

BUILDING PLAN
LEVEL 2

A3-1

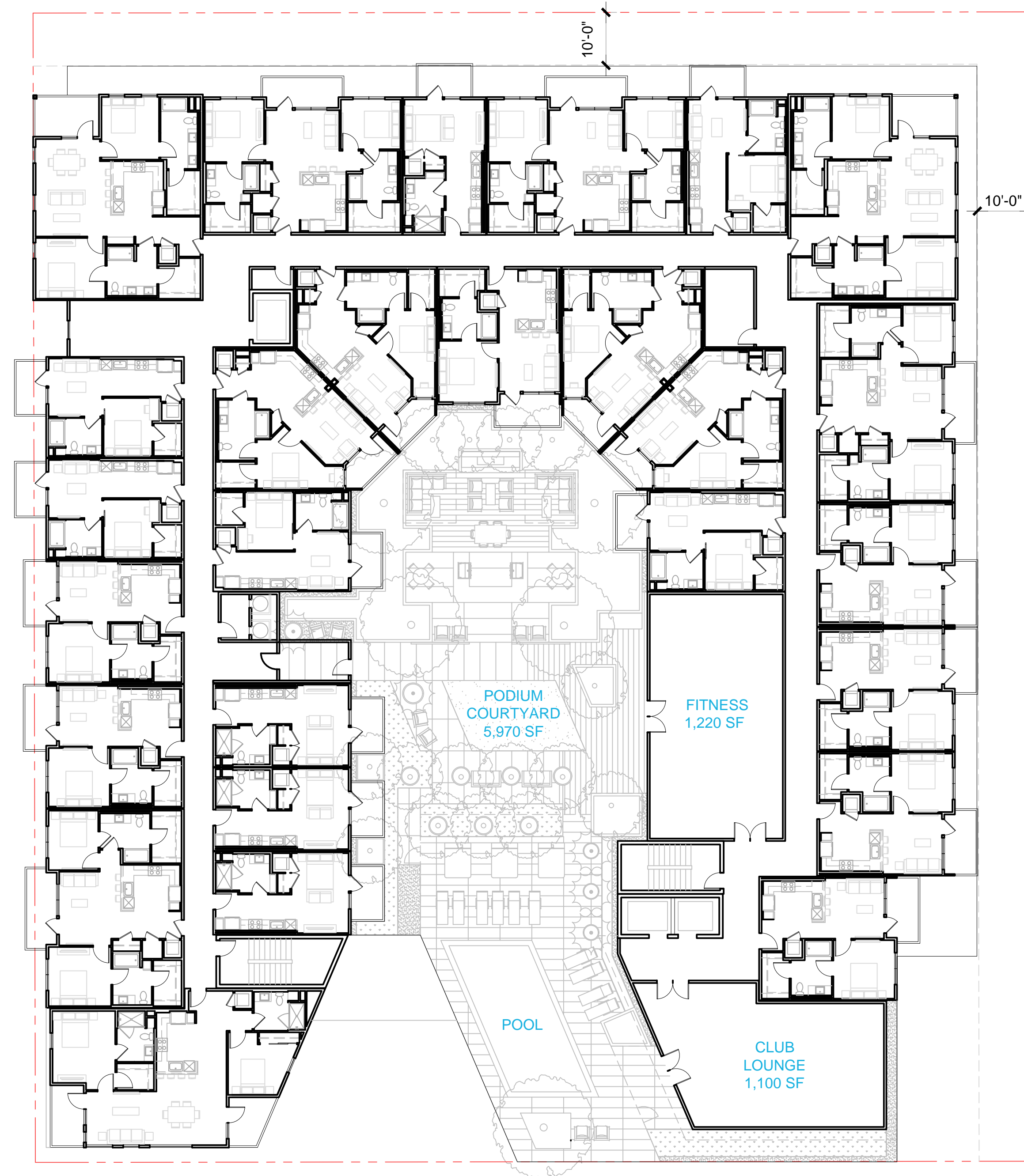

Architecture + Planning
888.456.5849
ktgy.com

Grubb Properties
4601 Park Road, Suite 450
Charlotte, NC 28209

1200 VINE STREET
LOS ANGELES, CA # 2021-1034

CONCEPTUAL DESIGN
APRIL 11, 2023

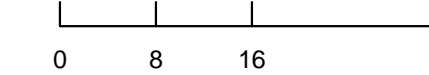
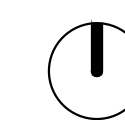

BUILDING PLAN
LEVEL 3

A3-2

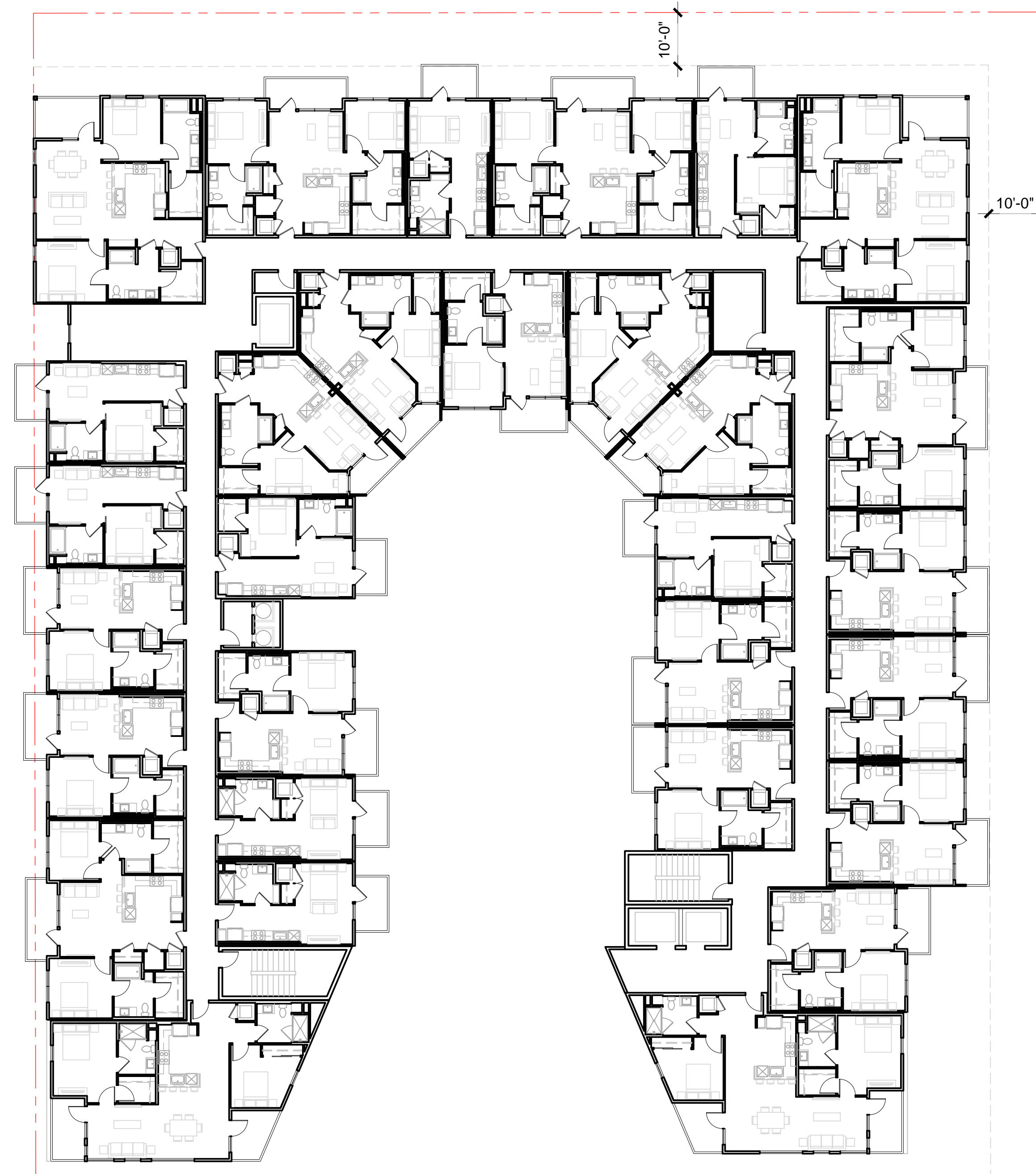

Architecture + Planning
888.456.5849
ktgy.com

Grubb Properties
4601 Park Road, Suite 450
Charlotte, NC 28209

1200 VINE STREET
LOS ANGELES, CA # 2021-1034

CONCEPTUAL DESIGN
APRIL 11, 2023

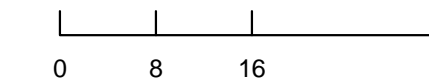
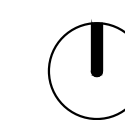

BUILDING PLAN
LEVEL 4-6

A3-3

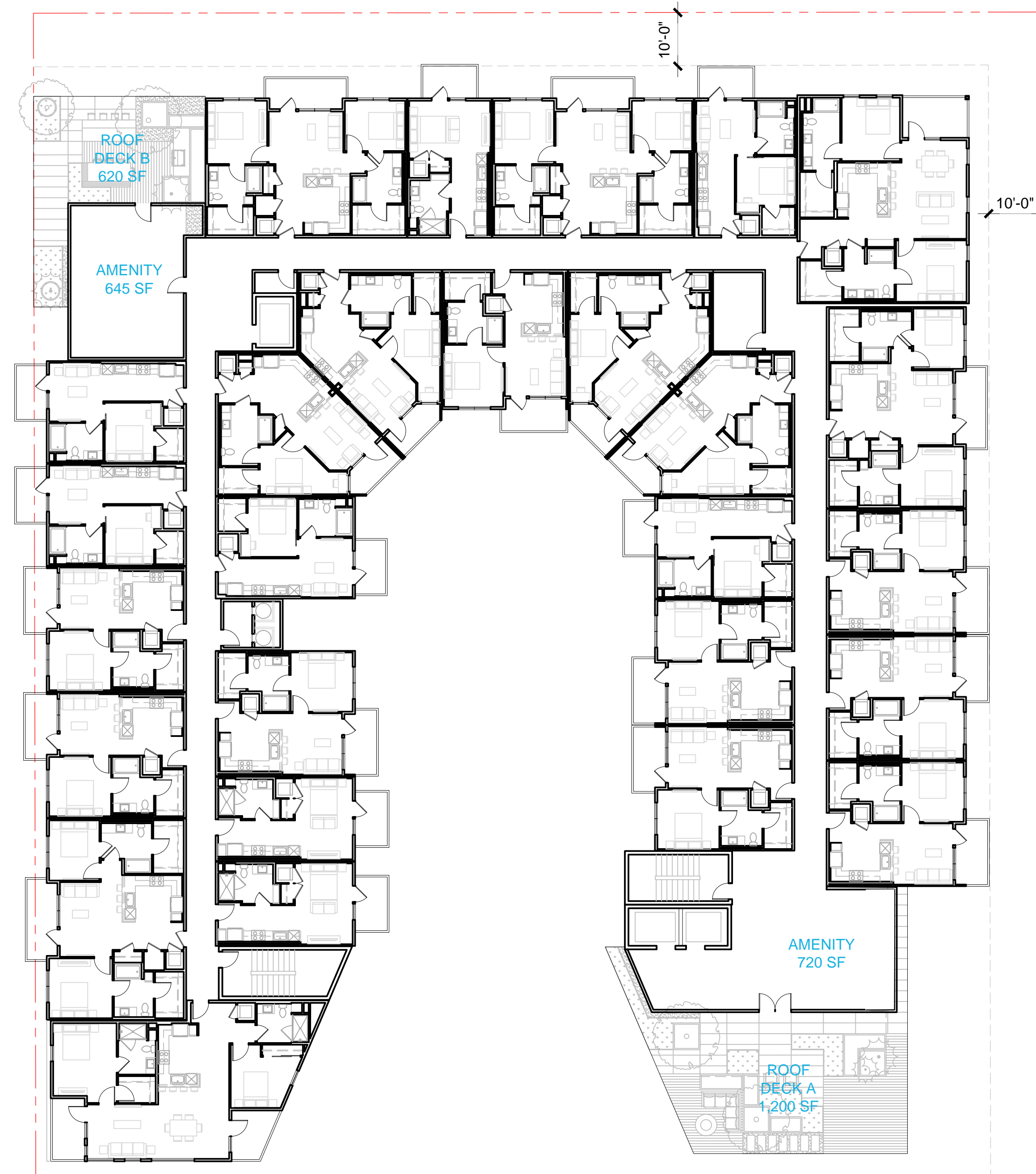

Architecture + Planning
888.456.5849
ktgy.com

Grubb Properties
4601 Park Road, Suite 450
Charlotte, NC 28209

1200 VINE STREET
LOS ANGELES, CA # 2021-1034

CONCEPTUAL DESIGN
APRIL 11, 2023

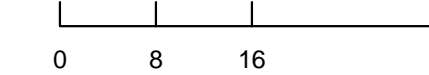
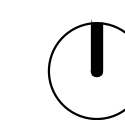

BUILDING PLAN
LEVEL 7

A3-4

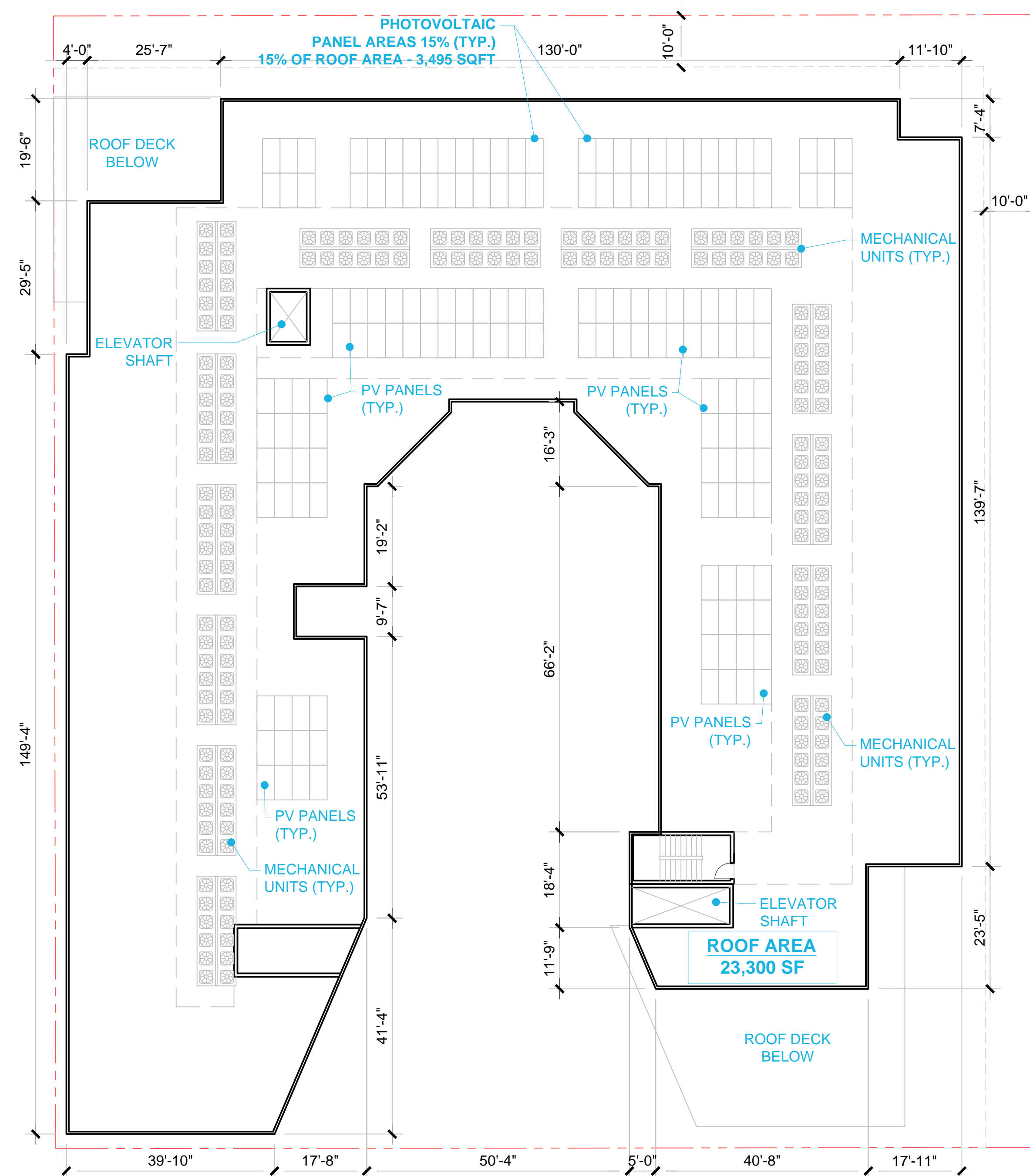

PHOTOVOLTAIC REQUIREMENT
15% OF THE ROOF AREA

ROOF AREA - 23,300 SQFT
_15% OF ROOF AREA A - 3,495 SQFT

TOTAL PHOTOVOLTAIC AREA ON ROOF
15% - 3,495 SQFT



Architecture + Planning
888.456.5849
ktgy.com

Grubb Properties
4601 Park Road, Suite 450
Charlotte, NC 28209

1200 VINE STREET
LOS ANGELES, CA # 2021-1034

CONCEPTUAL DESIGN
APRIL 11, 2023



BUILDING ROOF PLAN

A3-5

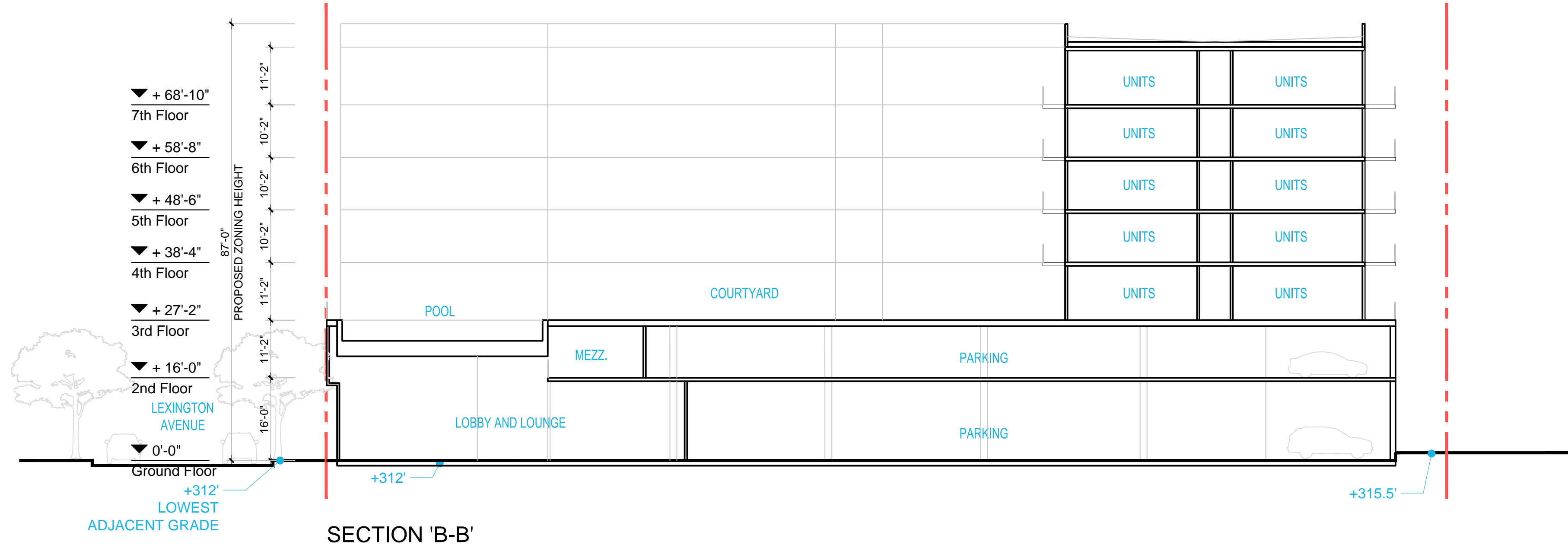
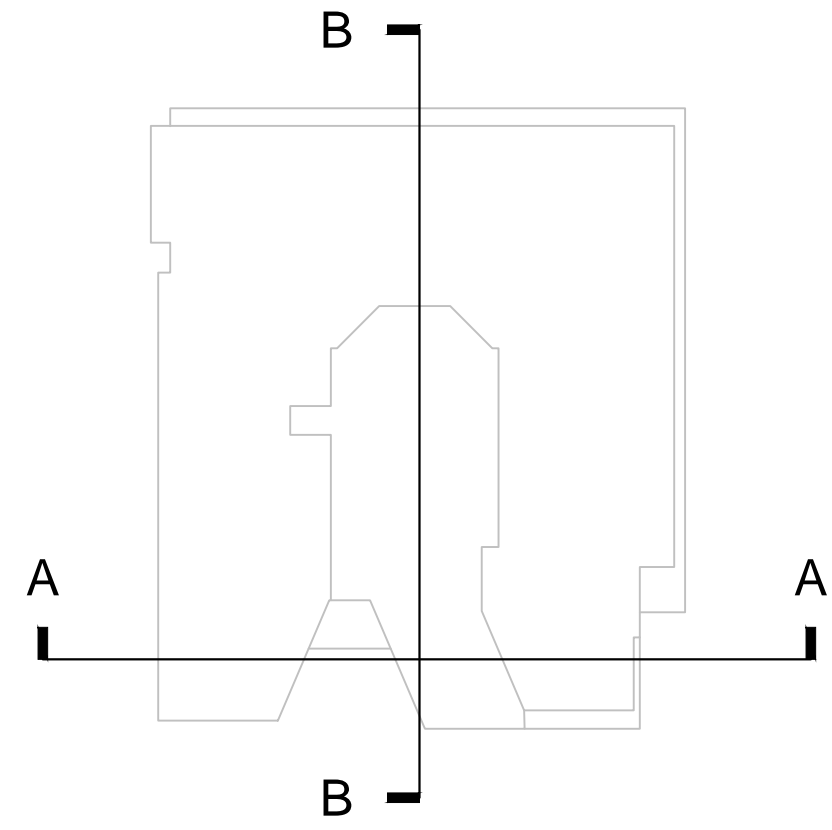
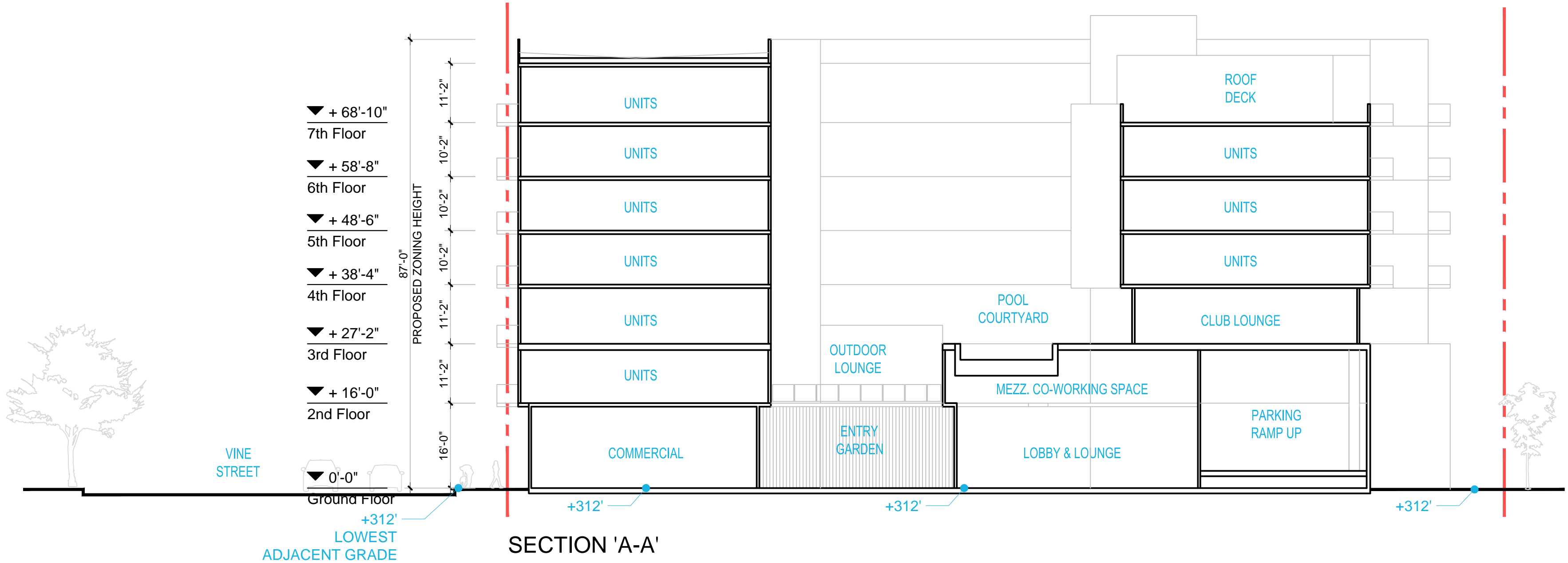

Architecture + Planning
888.456.5849
ktgy.com

Grubb Properties
4601 Park Road, Suite 450
Charlotte, NC 28209

1200 VINE STREET
LOS ANGELES, CA # 2021-1034

CONCEPTUAL DESIGN
APRIL 11, 2023

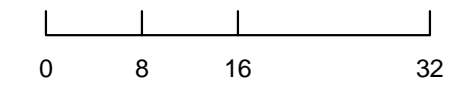

BUILDING SECTIONS
SECTION A-A & B-B

A4-0



SOUTH ELEVATION

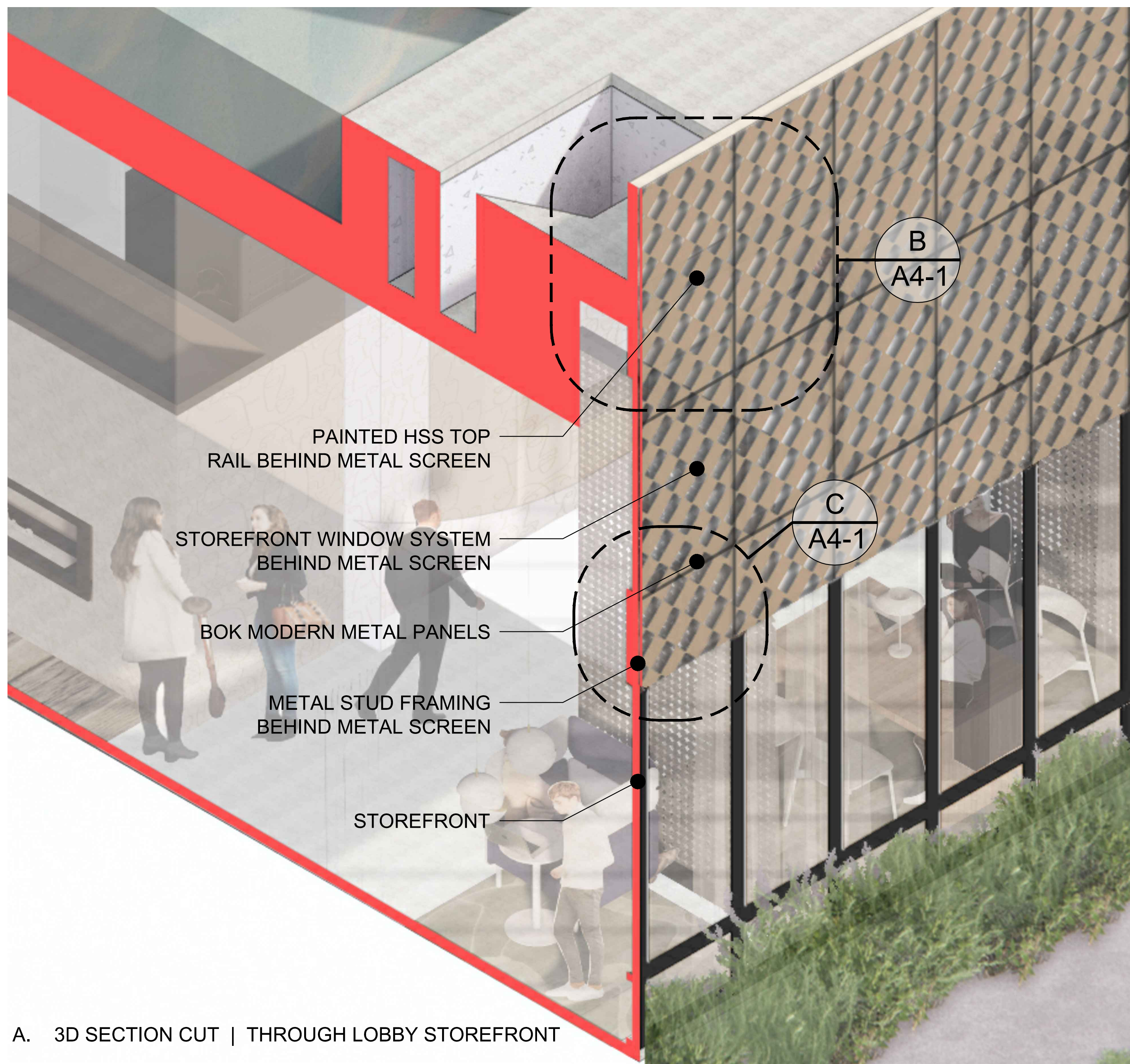
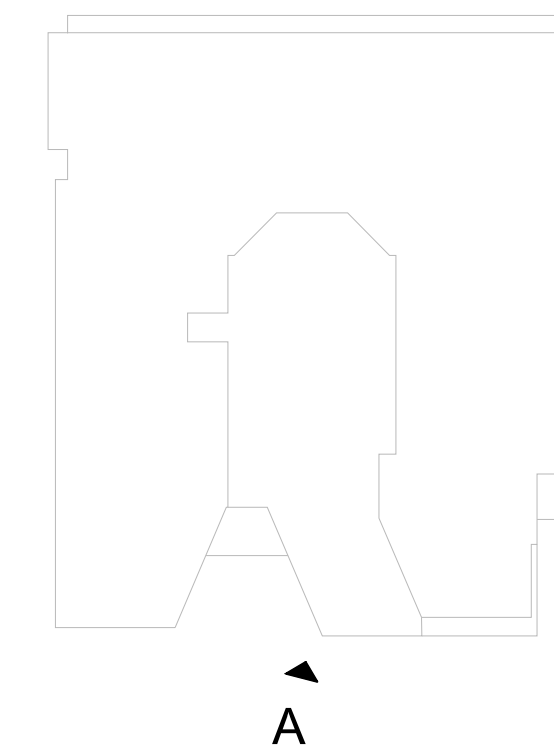

A. 3D SECTION CUT | THROUGH LOBBY STOREFRONT

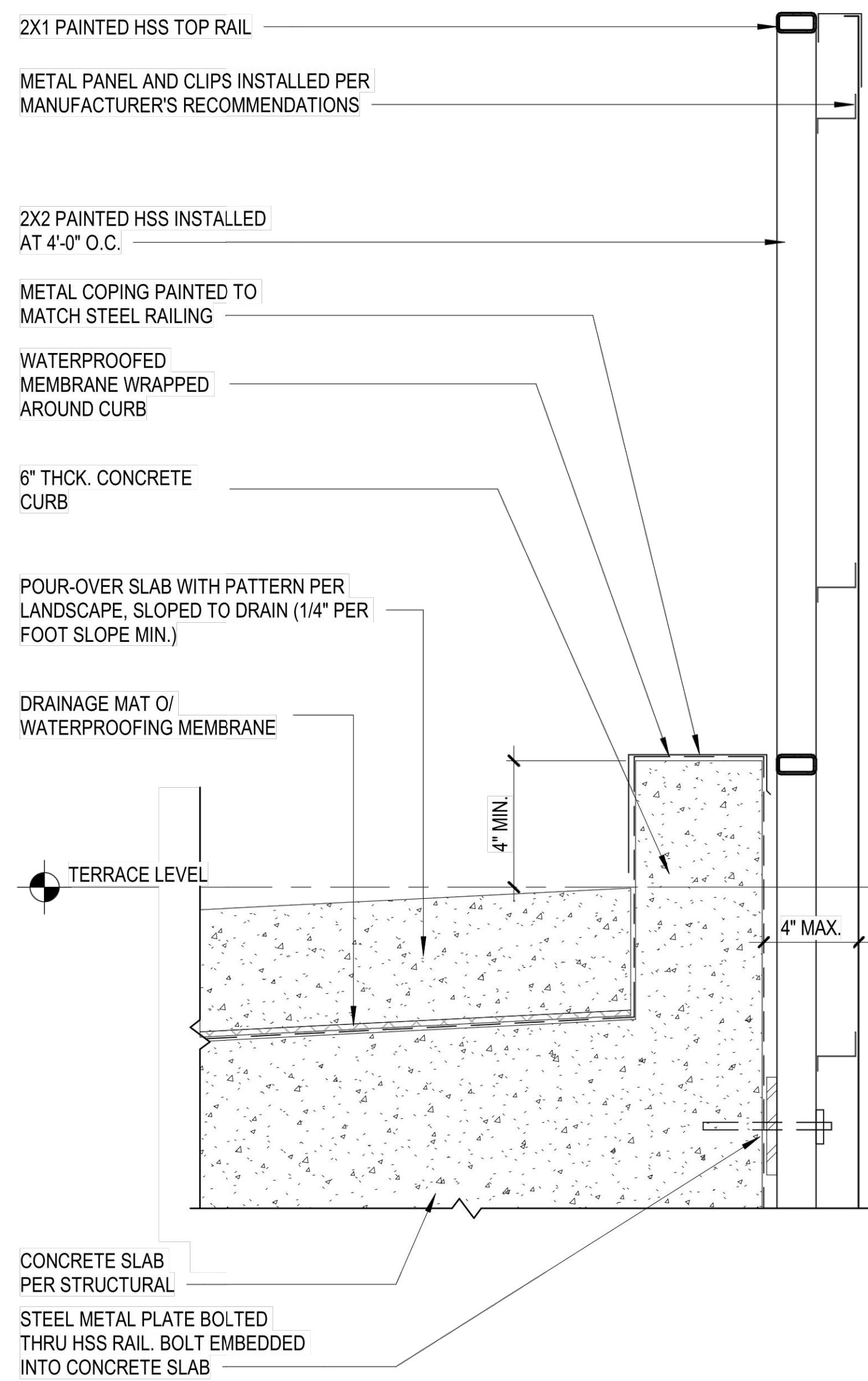

B. EXTERIOR METAL SCREEN AT TERRACE

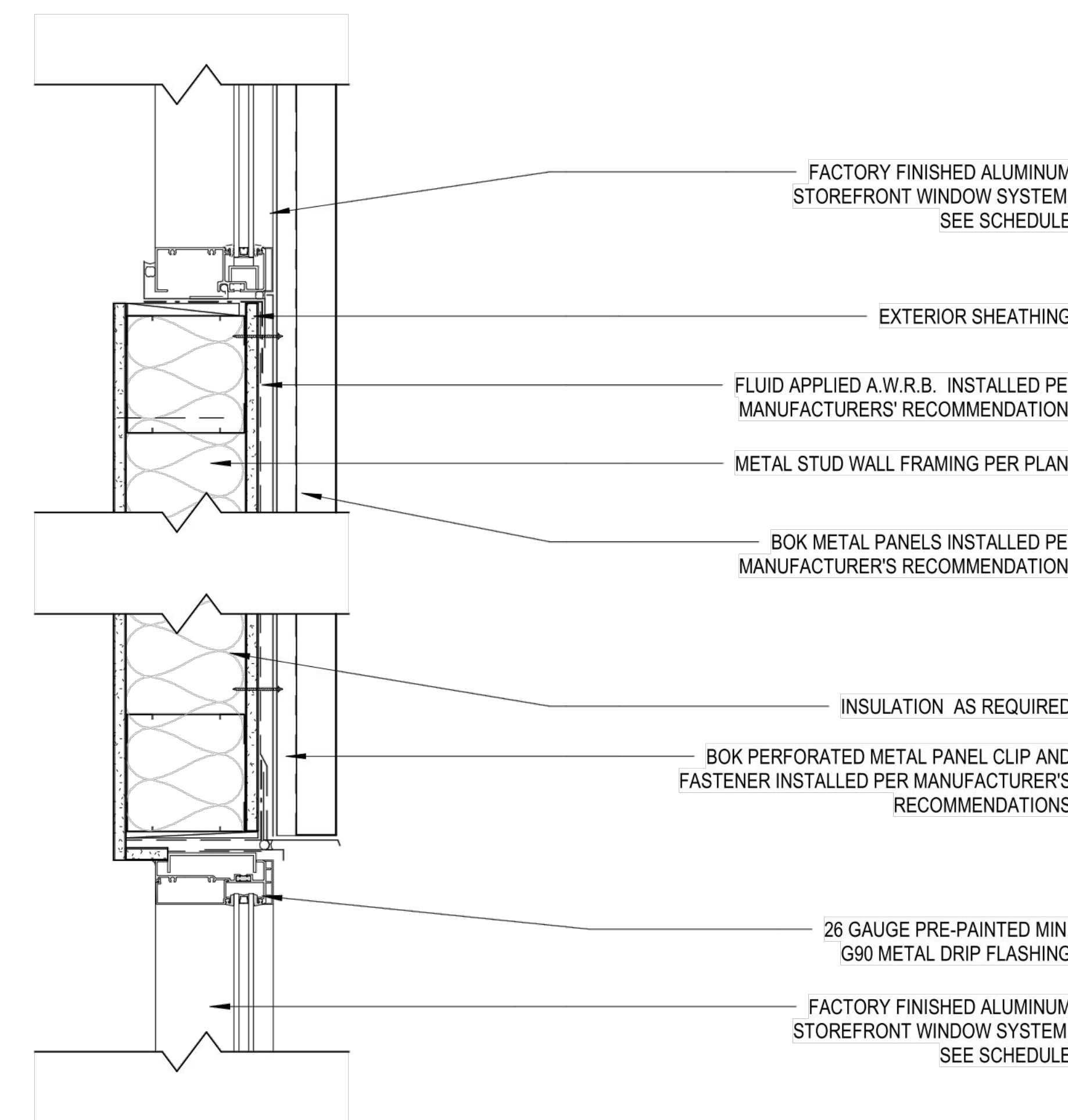

C. EXTERIOR METAL SCREEN AT STOREFRONT



Architecture + Planning
888.456.5849
ktgy.com

Grubb Properties
4601 Park Road, Suite 450
Charlotte, NC 28209

1200 VINE STREET
LOS ANGELES, CA # 2021-1034

CONCEPTUAL DESIGN
APRIL 11, 2023

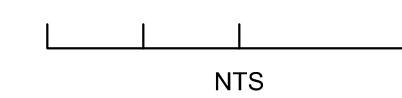

STOREFRONT & METAL SCREEN
SOUTH ELEVATION

A4-1

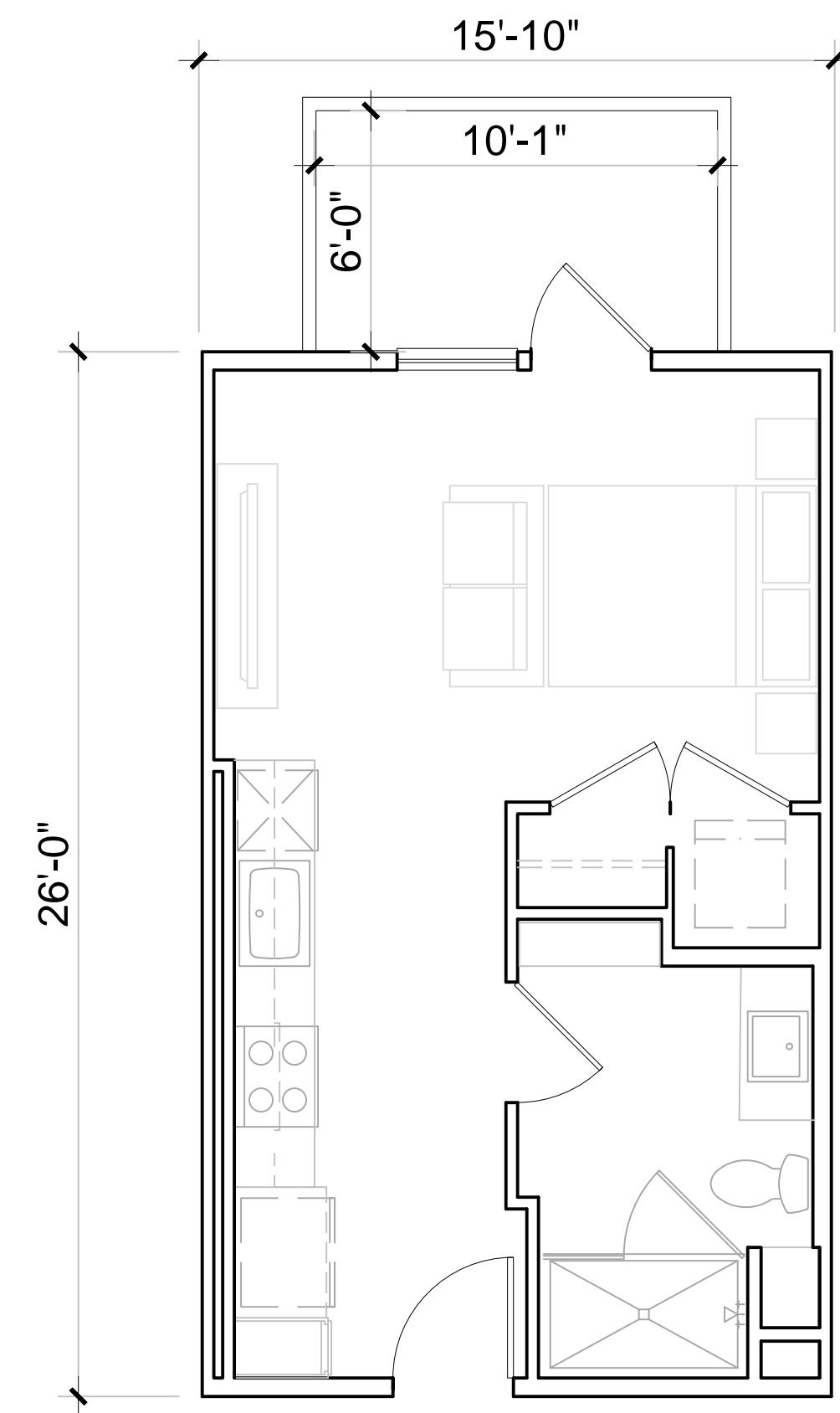

PLAN S1
STUDIO
1 BATH
412 SF

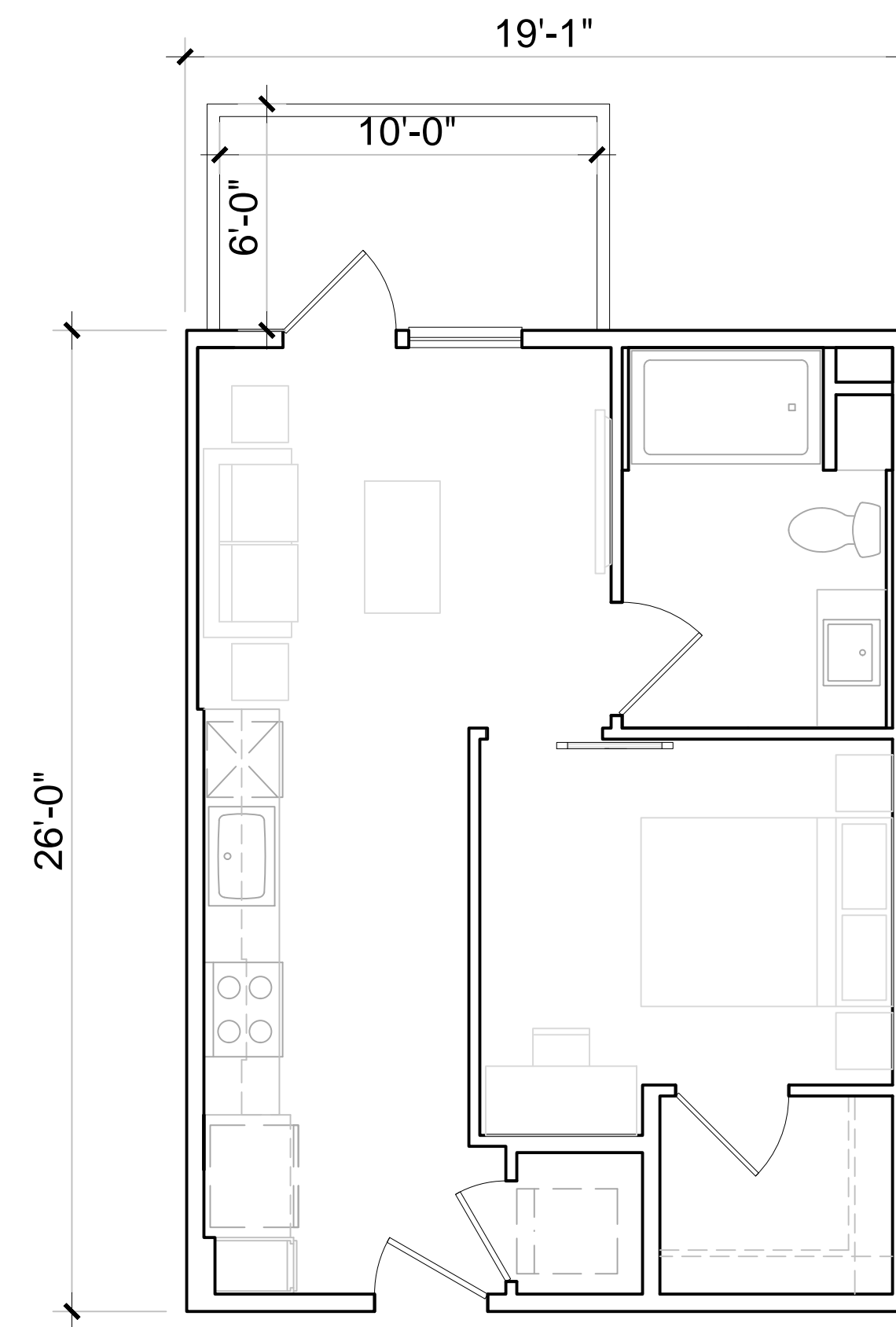

PLAN A1
1 BEDROOM
1 BATH
496 SF

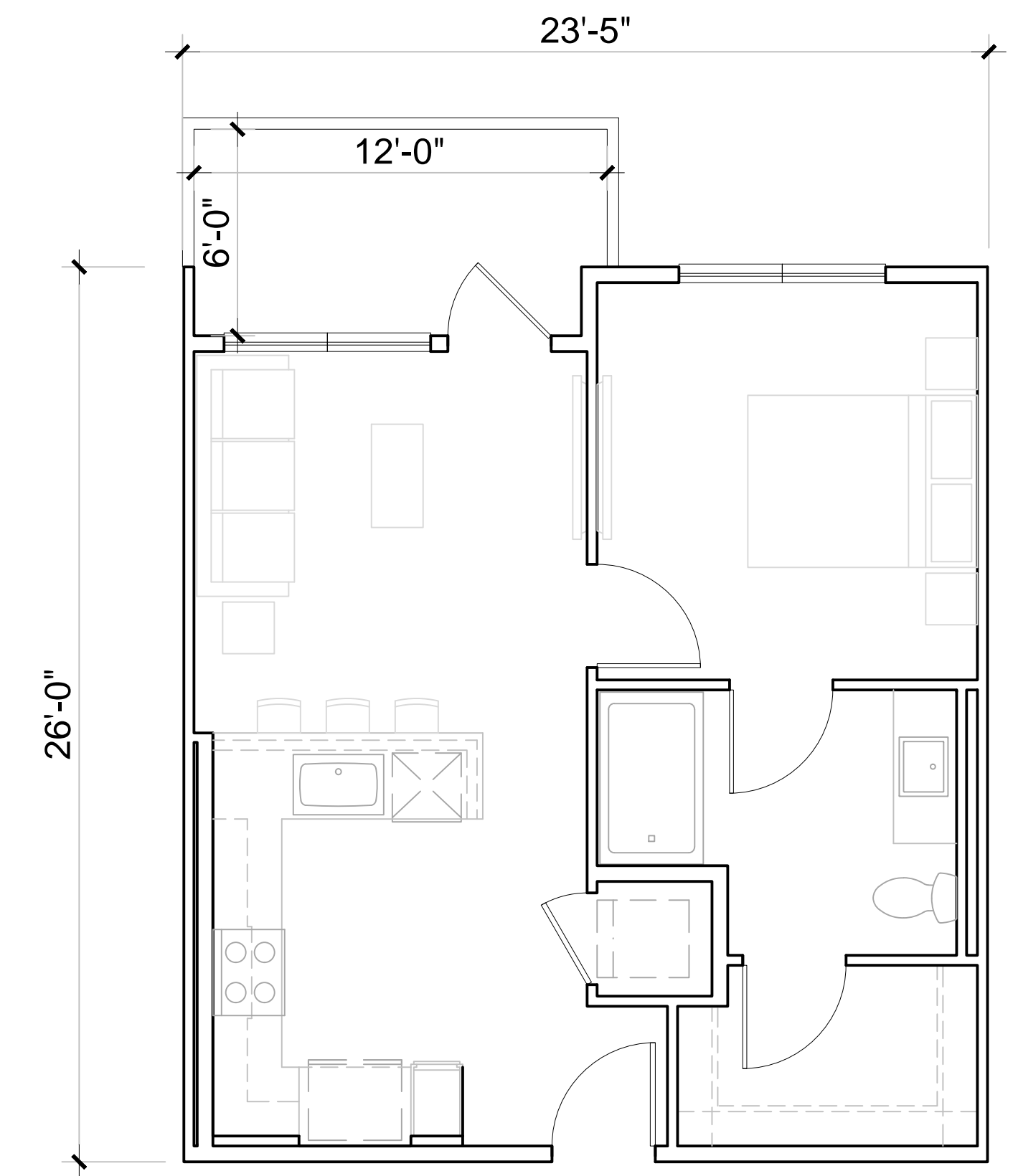

PLAN A2
1 BEDROOM
1 BATH
585 SF



Architecture + Planning
888.456.5849
ktgy.com

Grubb Properties
4601 Park Road, Suite 450
Charlotte, NC 28209

1200 VINE STREET
LOS ANGELES, CA # 2021-1034

CONCEPTUAL DESIGN
APRIL 11, 2023

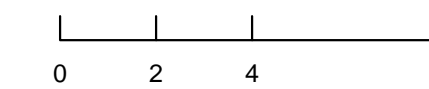

UNIT PLANS
STUDIOS AND 1-BEDROOM

A5-0

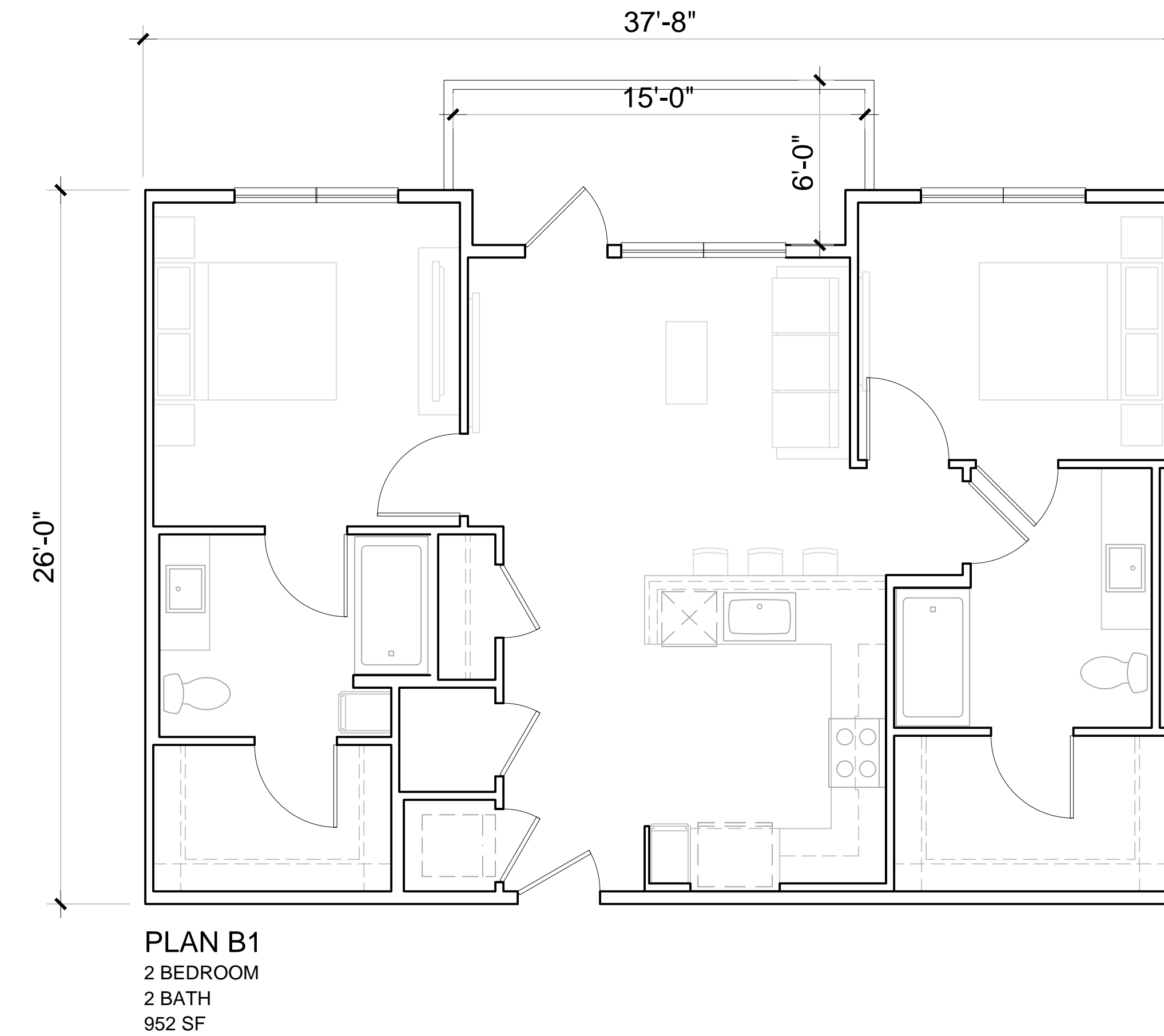
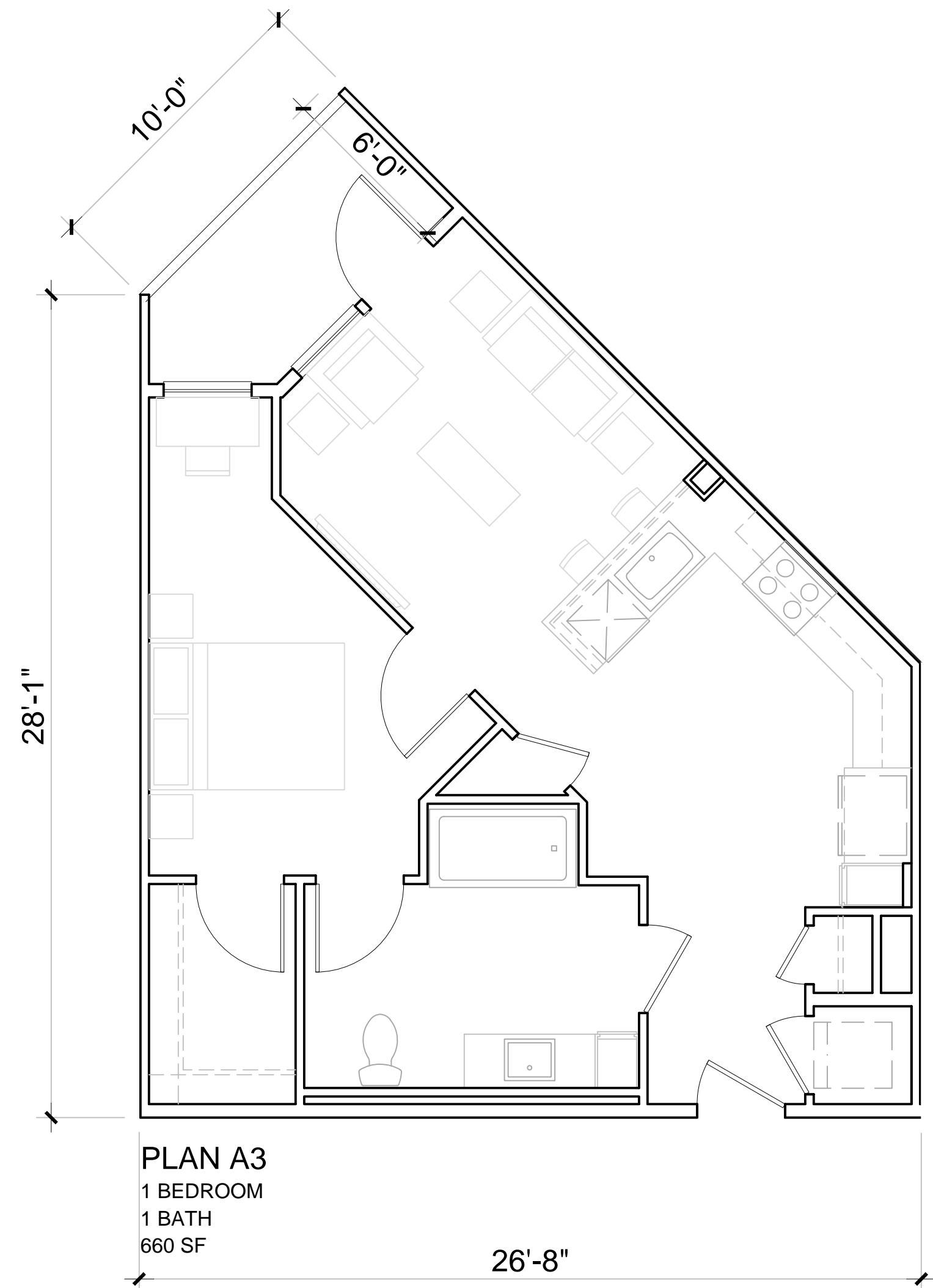

Architecture + Planning
 888.456.5849
 ktgy.com

Grubb Properties
 4601 Park Road, Suite 450
 Charlotte, NC 28209

1200 VINE STREET
 LOS ANGELES, CA # 2021-1034

CONCEPTUAL DESIGN
 APRIL 11, 2023

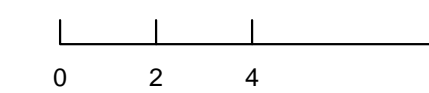

UNIT PLANS
 1-BEDROOMS AND 2-BEDROOM

A5-1

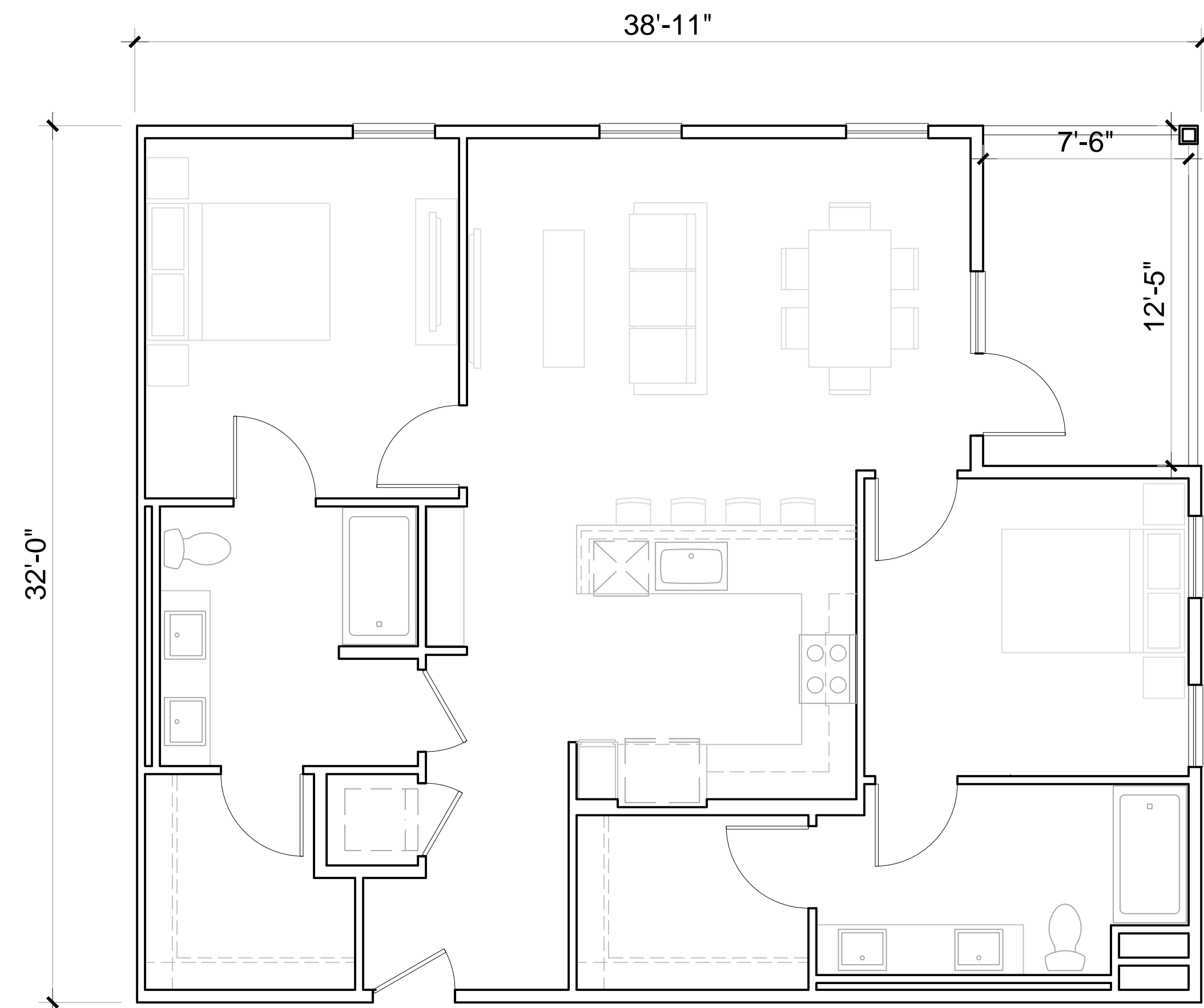

PLAN B3
 2 BEDROOM
 2 BATH
 1,145 SF

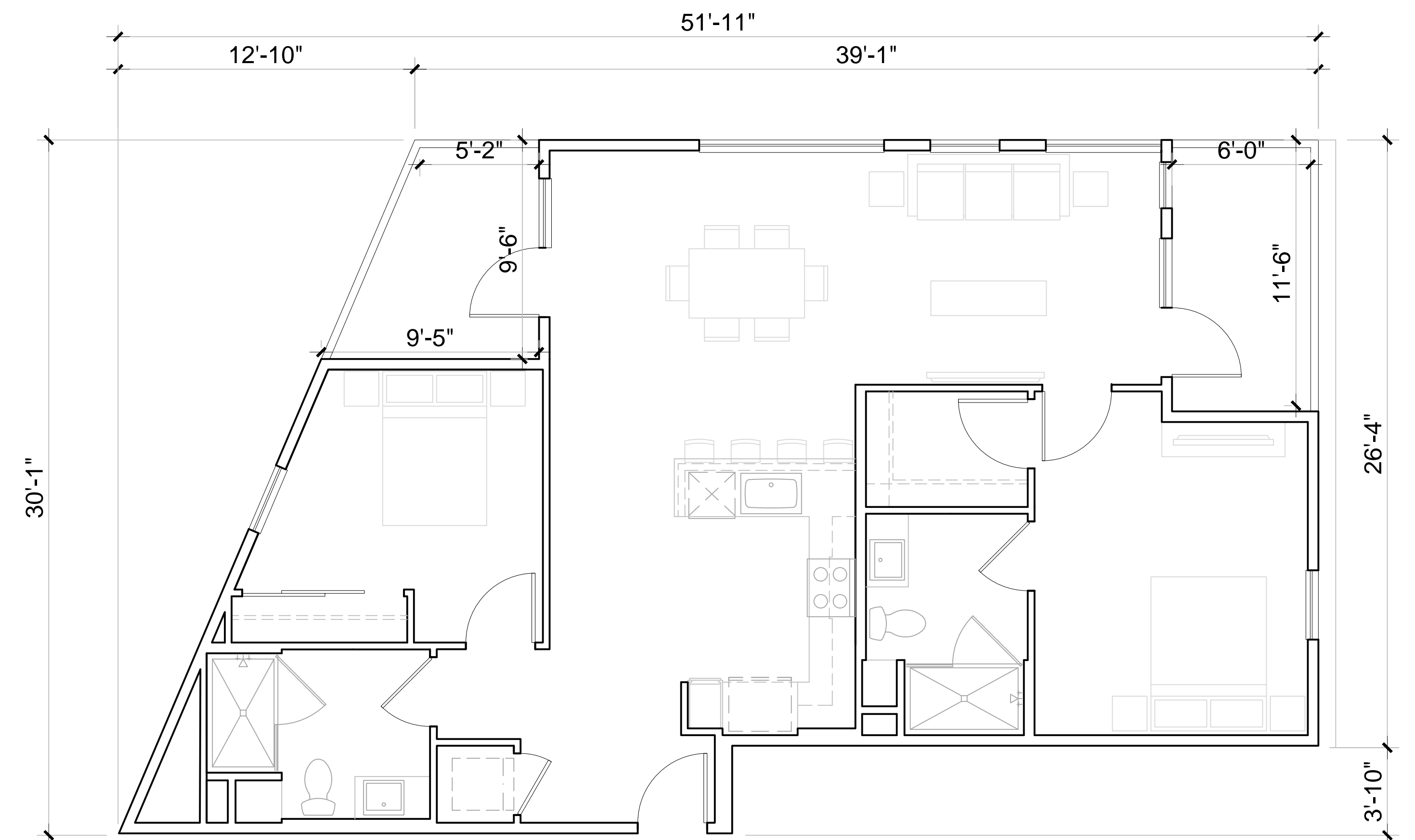

PLAN B3-ALT
 2 BEDROOM
 2 BATH
 1,130 SF



Architecture + Planning
888.456.5849
ktgy.com

Grubb Properties
4601 Park Road, Suite 450
Charlotte, NC 28209

1200 VINE STREET
LOS ANGELES, CA # 2021-1034

CONCEPTUAL DESIGN
APRIL 11, 2023

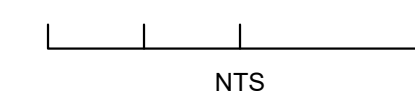

CONCEPTUAL PERSPECTIVES

A6-0



Architecture + Planning
888.456.5849
ktgy.com

Grubb Properties
4601 Park Road, Suite 450
Charlotte, NC 28209

1200 VINE STREET
LOS ANGELES, CA # 2021-1034

CONCEPTUAL DESIGN
APRIL 11, 2023

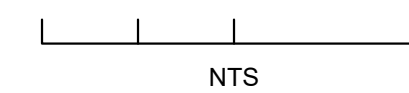

CONCEPTUAL PERSPECTIVES

A6-1



Architecture + Planning
888.456.5849
ktgy.com

Grubb Properties
4601 Park Road, Suite 450
Charlotte, NC 28209

1200 VINE STREET
LOS ANGELES, CA # 2021-1034

CONCEPTUAL DESIGN
APRIL 11, 2023

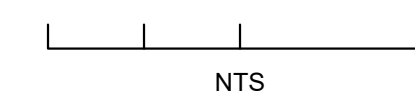

CONCEPTUAL PERSPECTIVES

A6-2



Architecture + Planning
888.456.5849
ktgy.com

Grubb Properties
4601 Park Road, Suite 450
Charlotte, NC 28209

1200 VINE STREET
LOS ANGELES, CA # 2021-1034

CONCEPTUAL DESIGN
APRIL 11, 2023

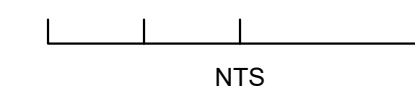

CONCEPTUAL PERSPECTIVES

A6-3



Architecture + Planning
888.456.5849
ktgy.com

Grubb Properties
4601 Park Road, Suite 450
Charlotte, NC 28209

1200 VINE STREET
LOS ANGELES, CA # 2021-1034

CONCEPTUAL DESIGN
APRIL 11, 2023

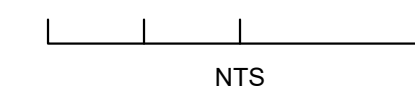

CONCEPTUAL PERSPECTIVES

A6-4

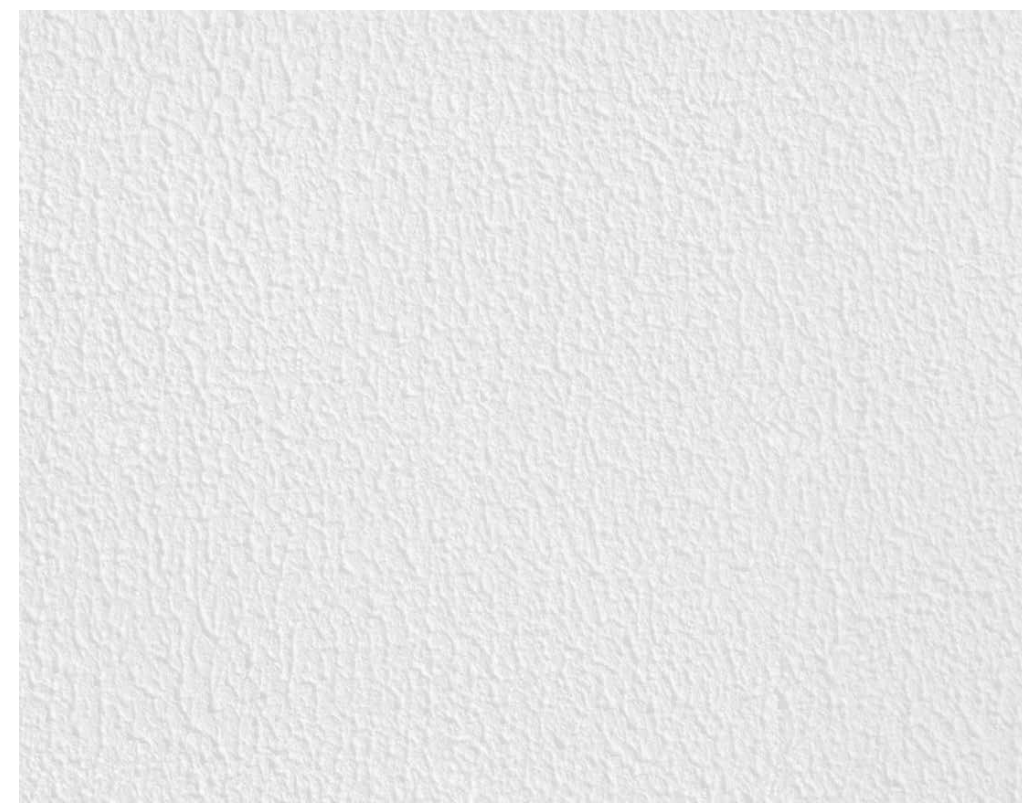

01_STUCCO BODY 01
20/30 FINISH



02_STUCCO BODY 02
SMOOTH FINISH



03_STUCCO BODY 03
20/30 FINISH

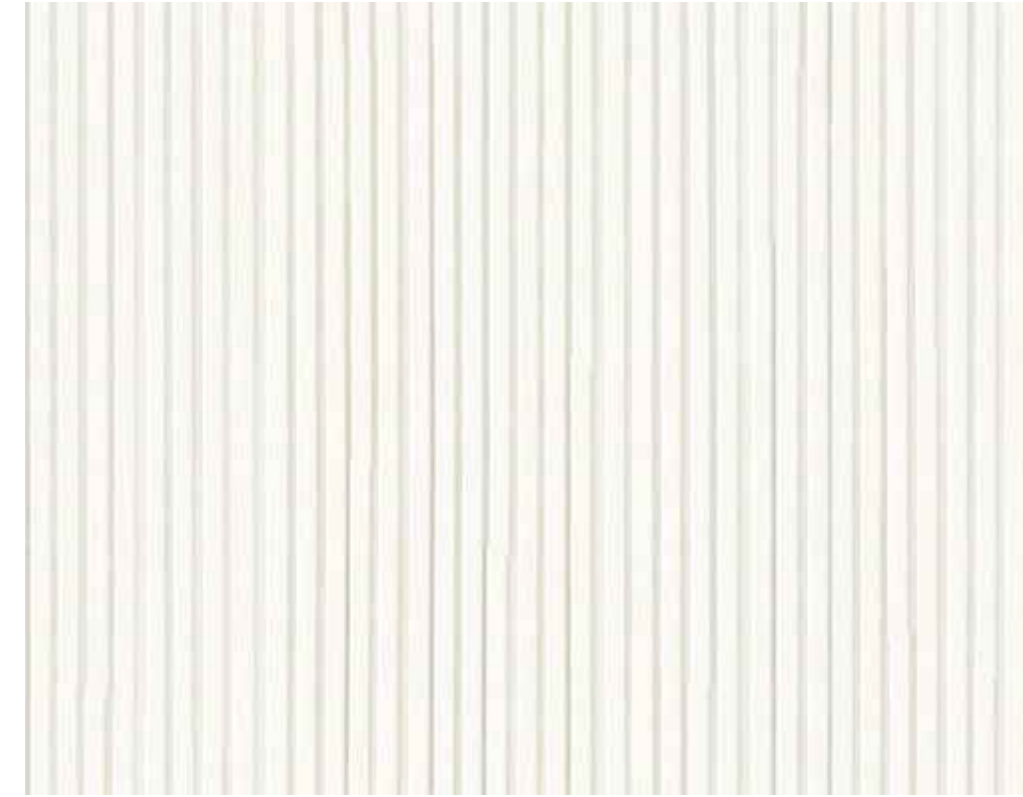

04_FIBER-CEMENT PANEL 01
CERACLAD_MODERN STRIPE

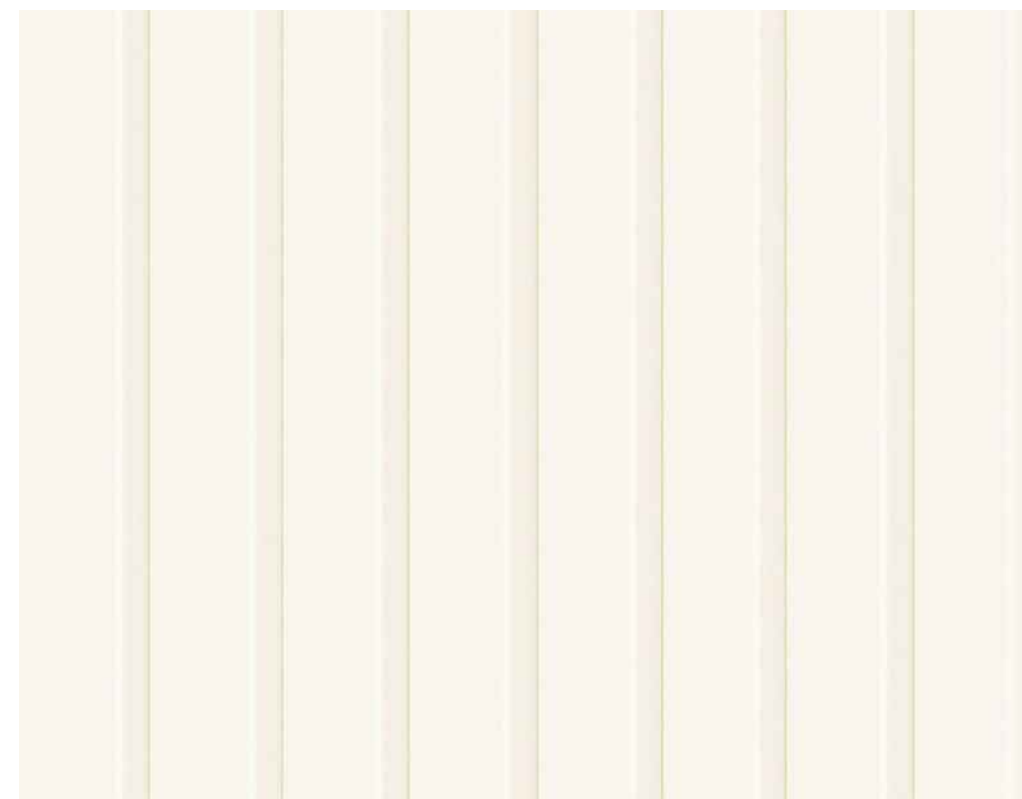

05_FIBER-CEMENT PANEL 02
CERACLAD_8-REVEAL

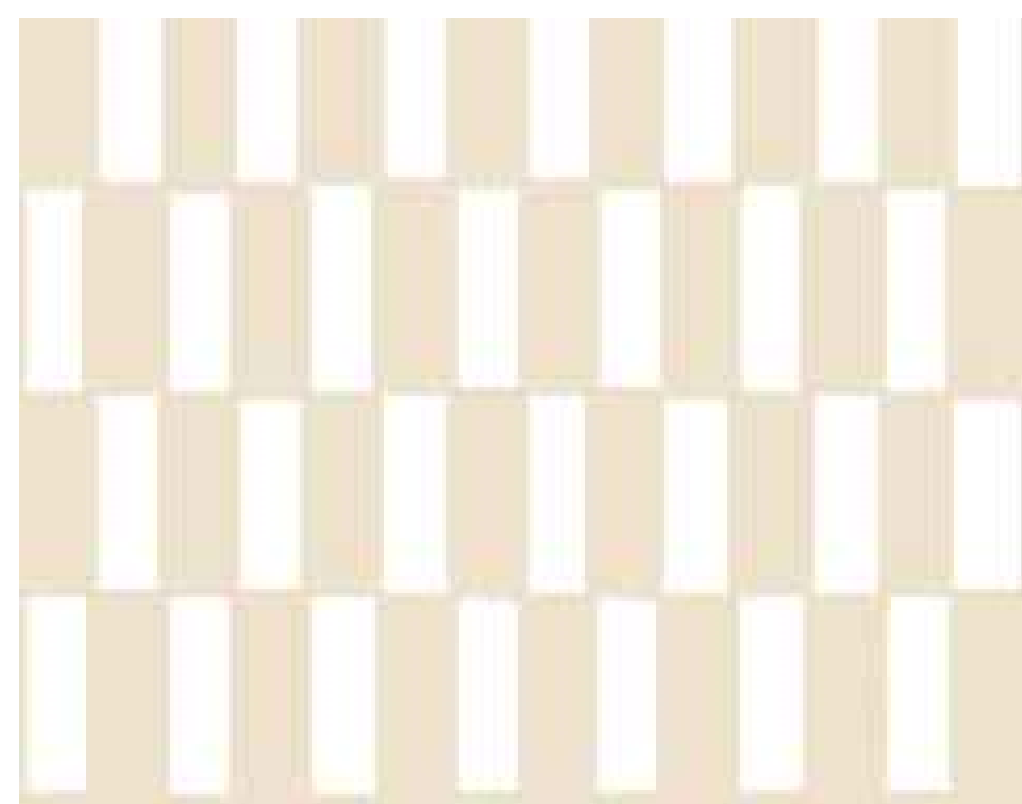

07_BOK MODERN METAL PANEL



08_NATURAL STONE TILE

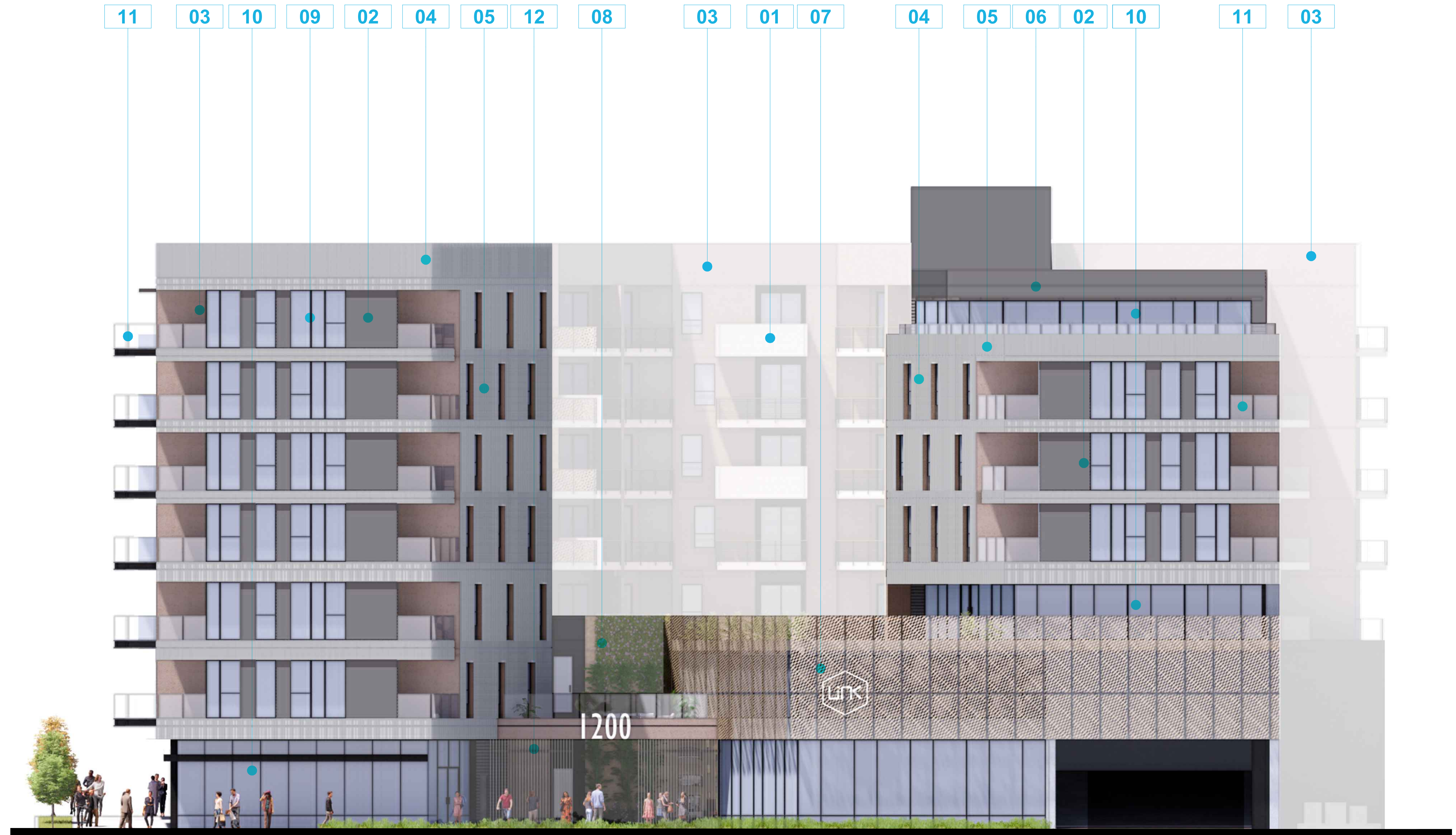

A | SOUTH ELEVATION

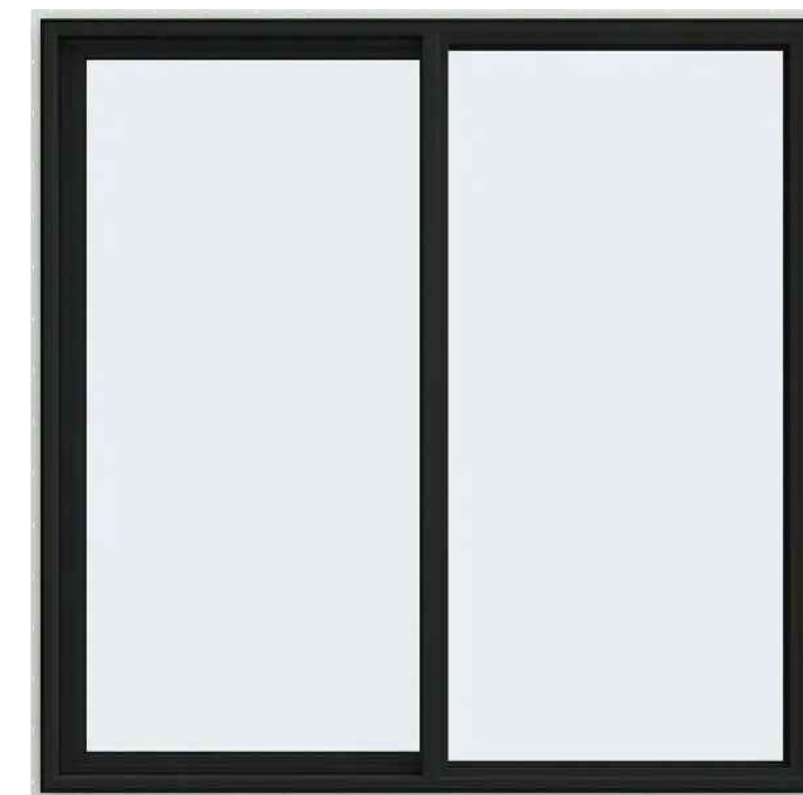

09_VINYL WINDOWS



10_DARK BRONZE STOREFRONT

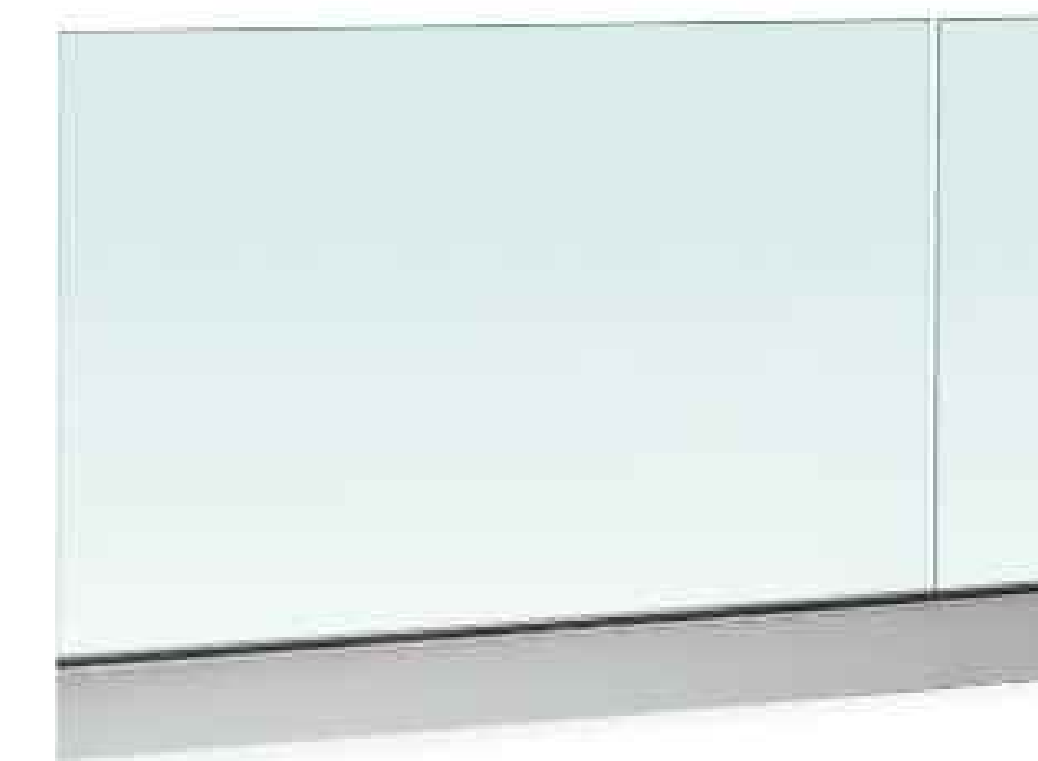

11_GLASS GUARDRAILS



13_VERTICAL ALUMINUM LOUVRES



Architecture + Planning
888.456.5849
ktgy.com

Grubb Properties
4601 Park Road, Suite 450
Charlotte, NC 28209

1200 VINE STREET
LOS ANGELES, CA # 2021-1034

CONCEPTUAL DESIGN
APRIL 11, 2023

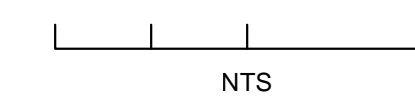

COLOR AND MATERIALS

A8-0



Dero Duplex

The Dero Duplex doubles the capacity of your bike parking area with secure, efficient, and orderly storage. Its staggered design means that bikes enter and exit easily without entanglement. Sturdy trays with high sides keep bikes from slipping off while loading or unloading and also make the Duplex compatible with most standard u-locks.

Patent D768,545

©2021

GUIDE SPECIFICATIONS FOR THE DUPLEX BIKE RACK SECTION 129313 BIKE RACKS

These specifications were current at the time of publication but are subject to change at any time without notice. Please confirm the accuracy of these specifications with the manufacturer and/or distributor prior to installation.

PART 1 GENERAL

1.1 Summary

This section includes specifications for the Duplex Bike Rack.

Modular system.

1.2 Quality Assurance

Installer Qualifications: An experienced installer who has completed installation of bicycle racks similar in material, design, and extent to that indicated for this project and whose work has resulted in construction with a record of successful in-service performance.

Manufacturer Qualifications: A firm experienced in manufacturing bicycle racks similar to those required for this project and with a record of successful in-service performance.

Source Limitations: Obtain each color, finish, shape and type of bicycle rack from a single source with resources to provide components of consistent quality in appearance and physical properties.

Product Options: Drawings indicate size, shape and dimensional requirements of bicycle racks and are based on the specific system indicated.

1.3 Submittals

Product Data: Include physical characteristics such as shape, dimensions, bicycle, material parking capacity and finish for each bicycle rack.

Shop Drawings: Show installation details for each bicycle rack.

Samples for Verification: Submit finish samples for review and verification.

Maintenance Data: For each bicycle rack.

Include recommended methods for repairing damage to the finish.

1.4 Delivery, Storage and Handling

A. Upon delivery, before signing for shipment, inspect for any damages and notate on the B.O.L.

B. Store bicycle racks in original undamaged packages and containers until ready for installation. Handle bicycle racks with sufficient care to prevent any scratches or damage to the finish.

1.5 Warranty

A. Bicycle racks carry a one-year manufacturer's limited warranty against defects in materials and workmanship. The one-year warranty period begins the date the product is shipped from the manufacturer.

PART 2 PRODUCTS

2.1 Acceptable Manufacturers

Provide bicycle racks manufactured by DERO BIKE RACK CO., 5522 Lakeland Avenue N., Minneapolis, MN 55429, 1-888-337-6729. Fax: 612-331-2731 Website: www.dero.com

2.2 Materials

Main frame tube: 2" 11g square tube

Connector plates: 1/4" plate

Bike trays: 11g plate

Installation Method. Each connector plate accepts 3/8" wedge anchors.

2.3 Finishes

A. Finish: A hot-dipped galvanized finish is standard. Over 250 high quality TGIC powder-coated colors are available from Dero Bike Rack Co.

2.4 Duplex Bike Rack

A. Setbacks

Please see setback diagrams.

PART 3 EXECUTION

3.1 Ordering Information

A. When ordering or specifying this rack, make sure the product type, finish and fastener type (if applicable) are included. Contact your Dero representative for a current price list or to place an order.

3.2 Freight

Call 1-888-337-6729 for freight quotes.



Dero Duplex

Submittal Sheet

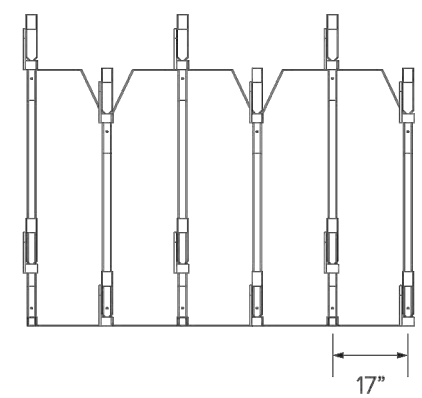
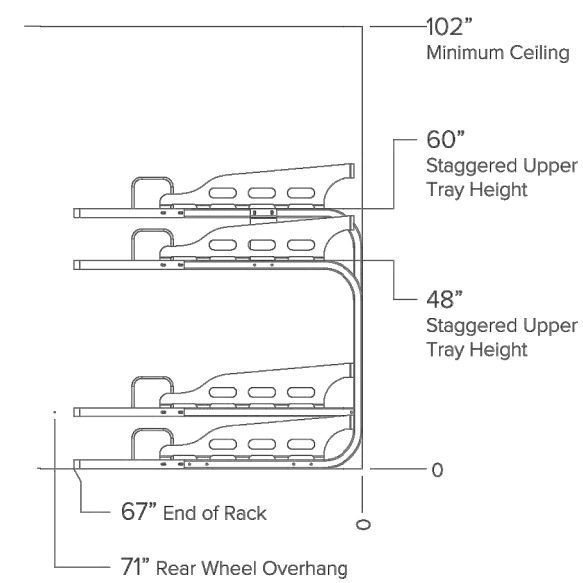

CAPACITY	Varies per configuration Minimum 6 bike system required for stability
MATERIALS	Main frame tube: 2" 11g square tube Connector plates: 1/4" plate Bike trays: 11g plate
FINISHES	<input type="checkbox"/> Galvanized An after fabrication hot dipped galvanized finish is our standard option. <input type="checkbox"/> Powder Coat Our powder coat finish assures a high level of adhesion and durability by following these steps: 1. Sandblast 2. Epoxy primer electrostatically applied 3. Final thick TGIC polyester powder coat <input type="checkbox"/> Stainless 304 grade stainless steel material with external surfaces polished to a satin finish. All surfaces passivated.
MOUNT OPTIONS	Surface only Each connector plate accepts 3/8" wedge anchors.

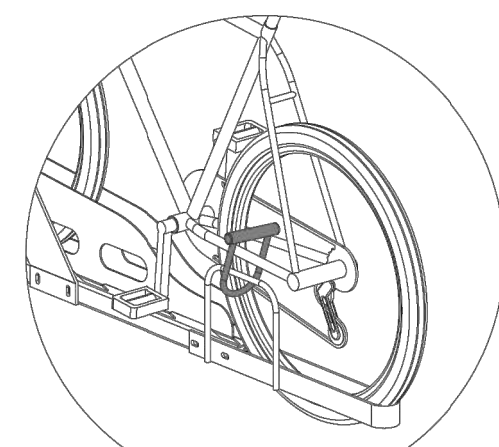

U-lock compatible



Dero Duplex

Setbacks Single Sided

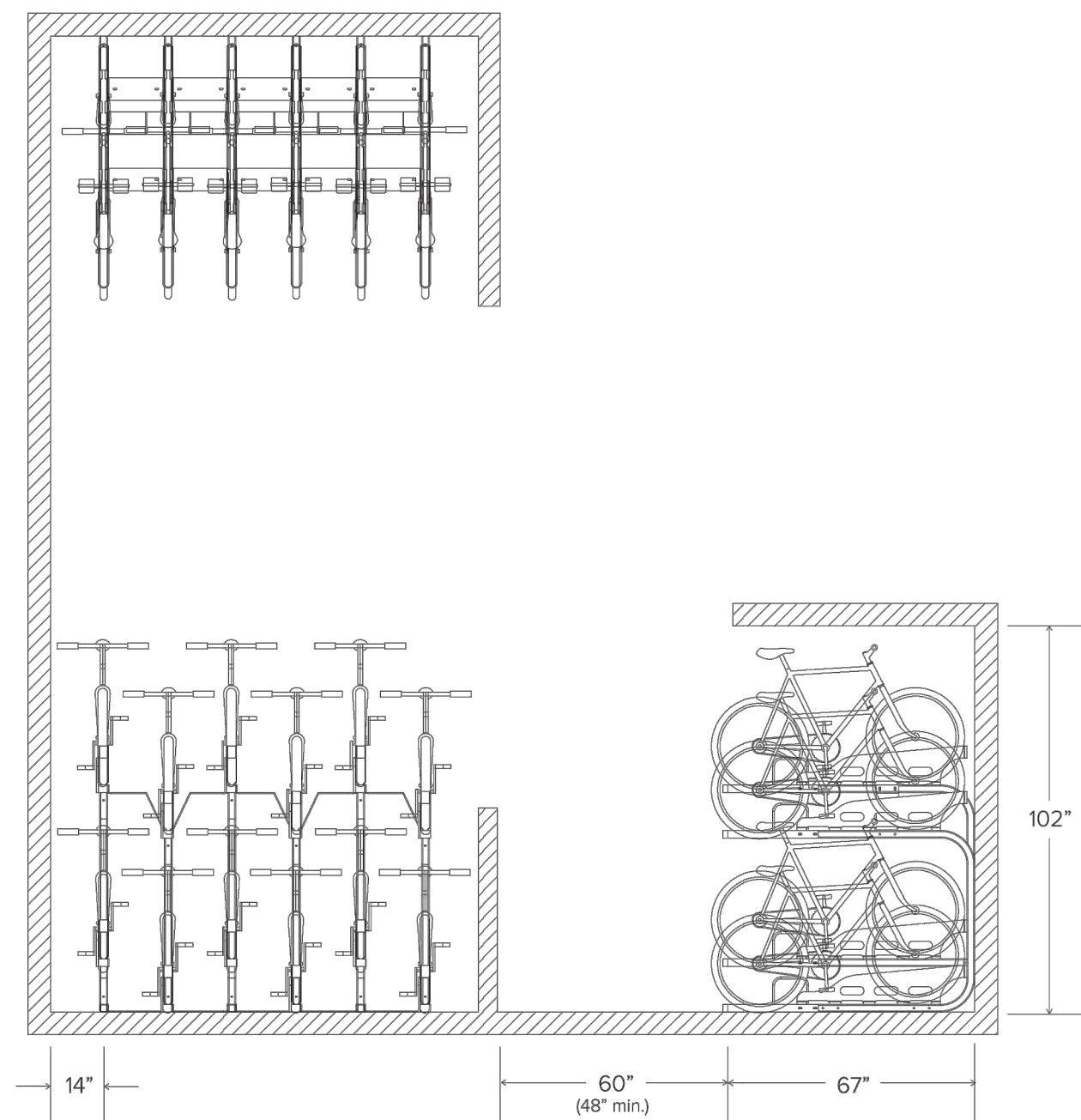

Architecture + Planning
888.456.5849
ktgy.com

Grubb Properties
4601 Park Road, Suite 450
Charlotte, NC 28209

1200 VINE STREET
LOS ANGELES, CA # 2021-1034

©2021

CONCEPTUAL DESIGN
APRIL 11, 2023

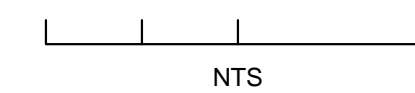

BICYCLE PARKING SPECS

A9-0

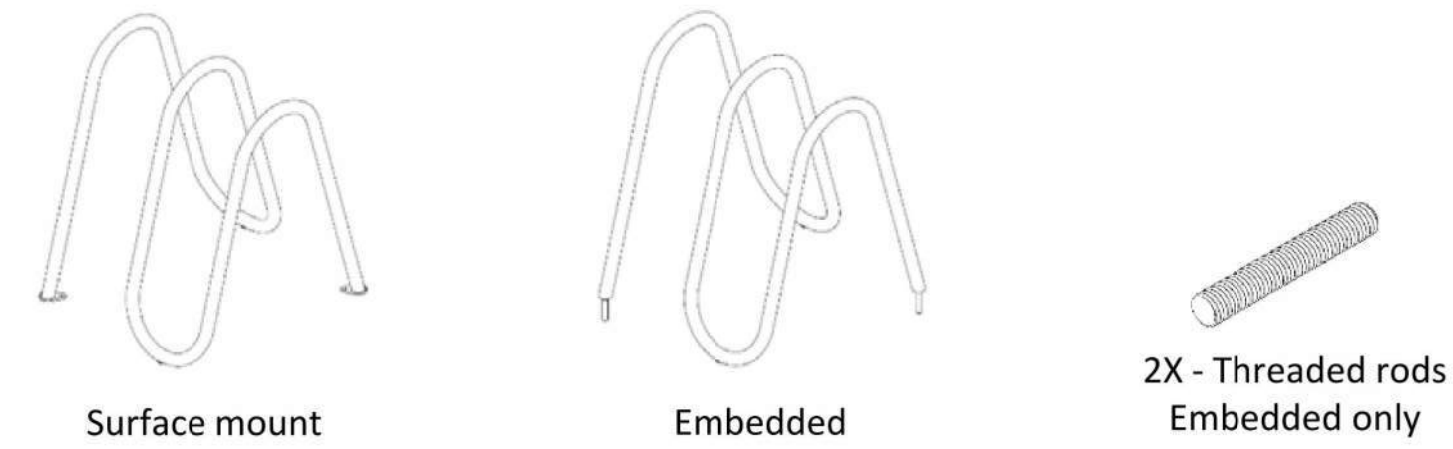

Included components:

- (2) 5/8-11 x 4" threaded rods with Loctite for embedded unit

Tools required:

- Surface mount unit ships fully assembled
- Surface mount option: (2) non-corrosive anchor bolts required per unit, maximum size $\varnothing 3/8"$ x 2-1/2" to 3" length
- Hammer drill with masonry bits
- For embedded mount option: chemical anchoring adhesive (Hilti HIT RE 500 or equivalent)

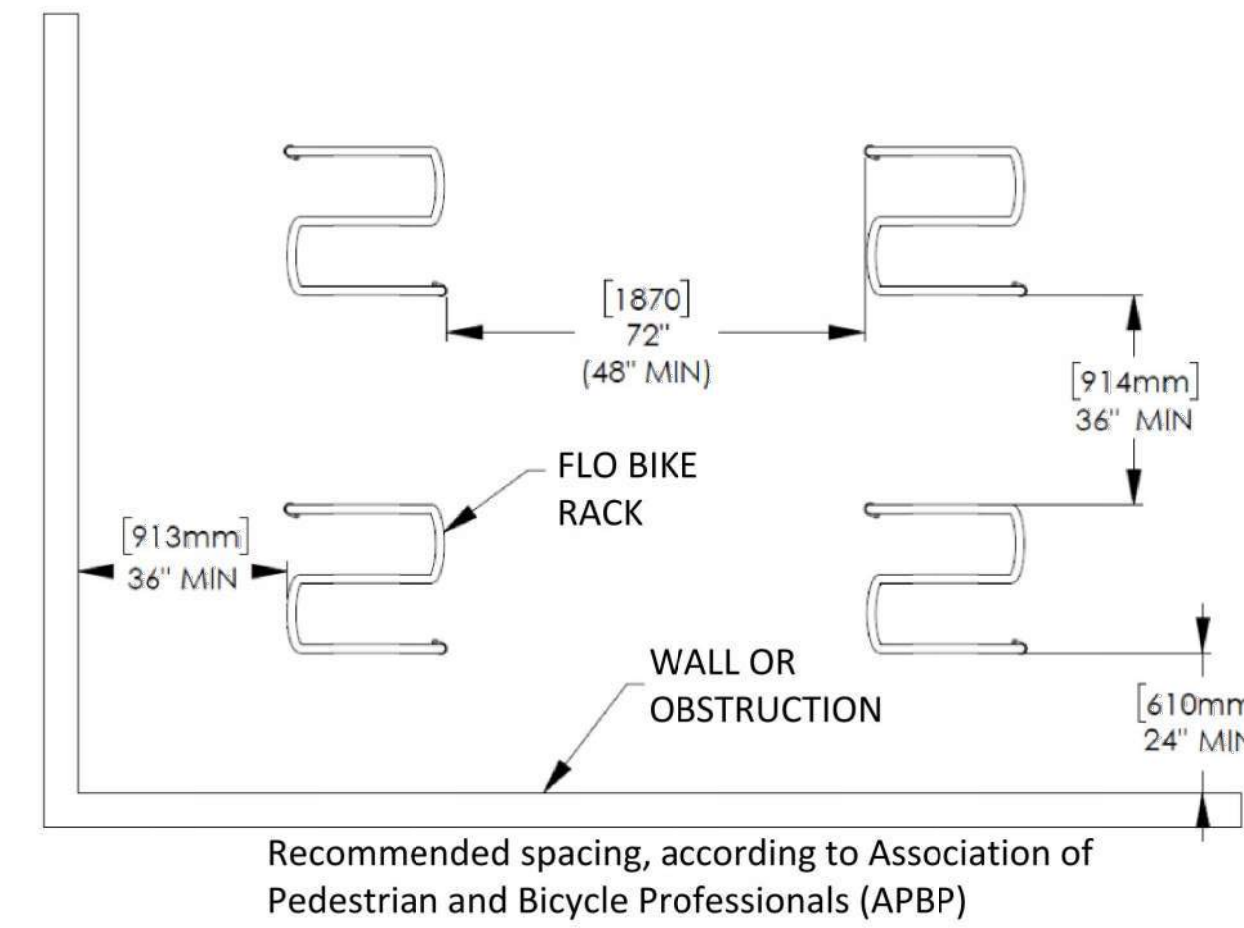

HANDLE WITH CARE! Flo's finish can be scuffed by contact with tools, concrete, or other abrasive surfaces. Protect the finish from damage during installation. Use touch-up paint to repair any powder coat finish abrasions.

EMBEDDED INSTALLATION:

1. Install thread patch ends of threaded rods into the bike rack legs.
2. Set unit in position and mark hole locations.
3. Move unit and drill 7/8" diameter (minimum) holes 3-1/2" deep.
4. Set unit in position to make sure that Nylon glides make contact with the surface. Threaded rods should not be resting on the bottom of the drilled hole.
5. Move unit. Clear holes of debris.
6. Fill holes with chemical anchoring adhesive.
7. Set unit in position.
8. Wipe away excess adhesive.

SURFACE MOUNT INSTALLATION:

1. Set unit in place and mark holes.
2. Move the unit and drill the holes.
3. Install the anchors and bike rack according to the anchor manufacturer's instructions. Be sure that both anchor plates make solid contact with the surface.

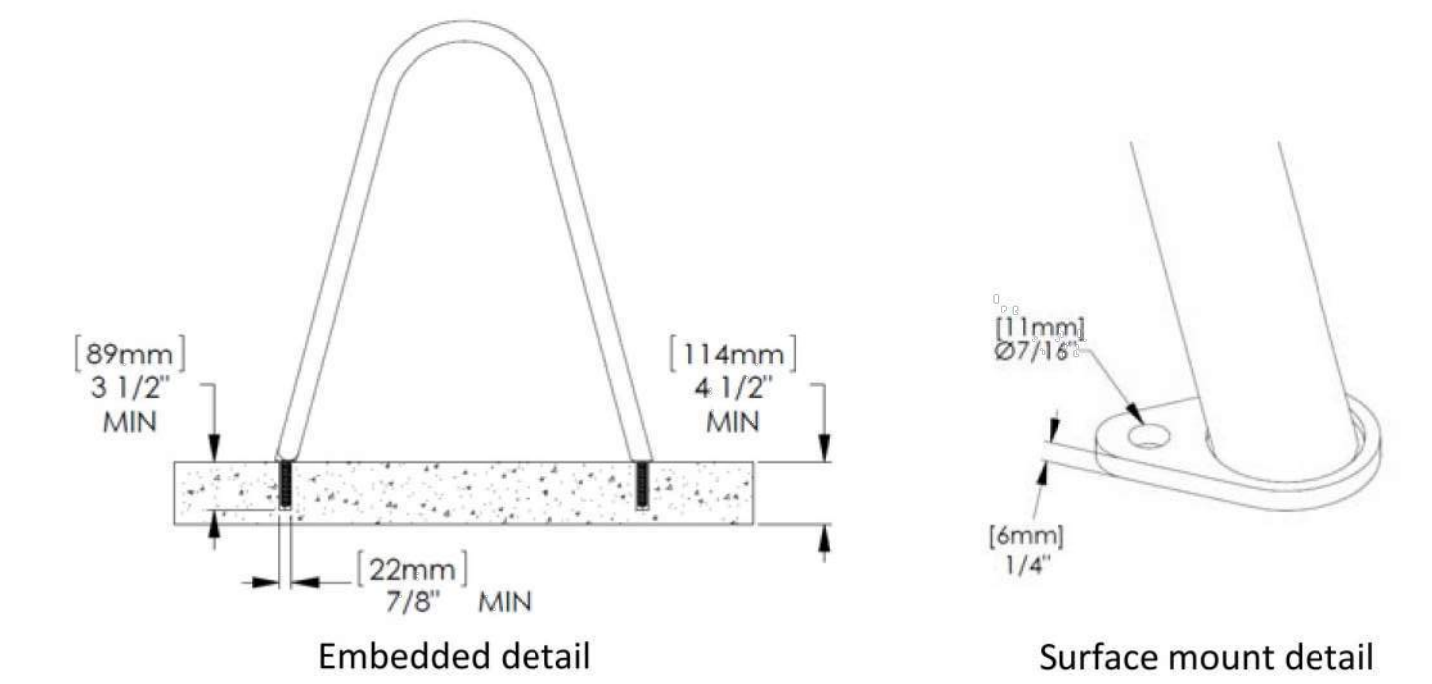

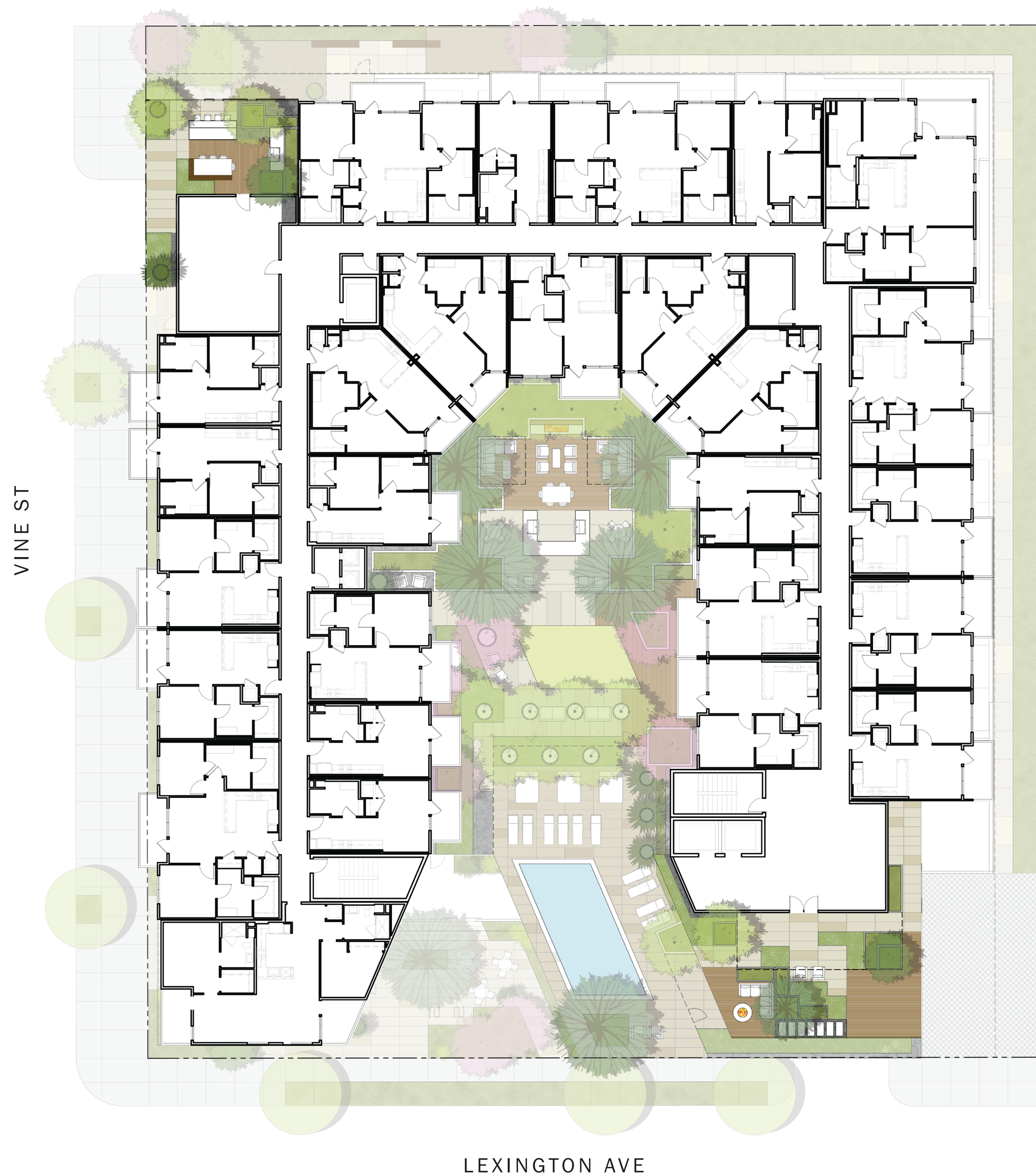

COMPOSITE LANDSCAPE PLAN

LANDSCAPE DATA

LANDSCAPE AREA	PROVIDED	HYDROZONE AREA	PROVIDED
Level 1	3213 SF	Very Low	895 SF
Level 3 Podium	2129 SF	Low	3875 SF
Level 7	619 SF	Moderate	1191 SF
Total	5961 SF	Total	5961 SF

EXTERIOR COMMON OPEN SPACE	PROVIDED	REQUIRED LANDSCAPE (25%)	PROPOSED LANDSCAPE
Level 1 Plaza	1200 SF	300 SF	394 SF
Level 3 Podium Courtyard	5970 SF	1493 SF	2129 SF
Level 7 Roof Deck A	1200 SF	300 SF	355 SF
Level 7 Roof Deck B	620 SF	155 SF	264 SF
Total	8990 SF	2248 SF	3142 SF

TREE COUNT	PROVIDED	REQUIRED
Level 1	9	TOTAL UNITS: 151 REQUIRED: (1) 24" BOX MIN. PER 4 UNITS
Level 3 Podium	23	
Level 7	6	
Total	38	38



Architecture + Planning
888.456.5849
ktgy.com



Grubb
4601 Park Road, Suite 450
Charlotte, NC 28209

1200 VINE STREET
LOS ANGELES, CA #2021-1034

CONCEPTUAL DESIGN
APRIL 11, 2023

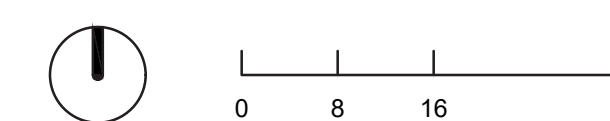

LANDSCAPE DATA

L0-1

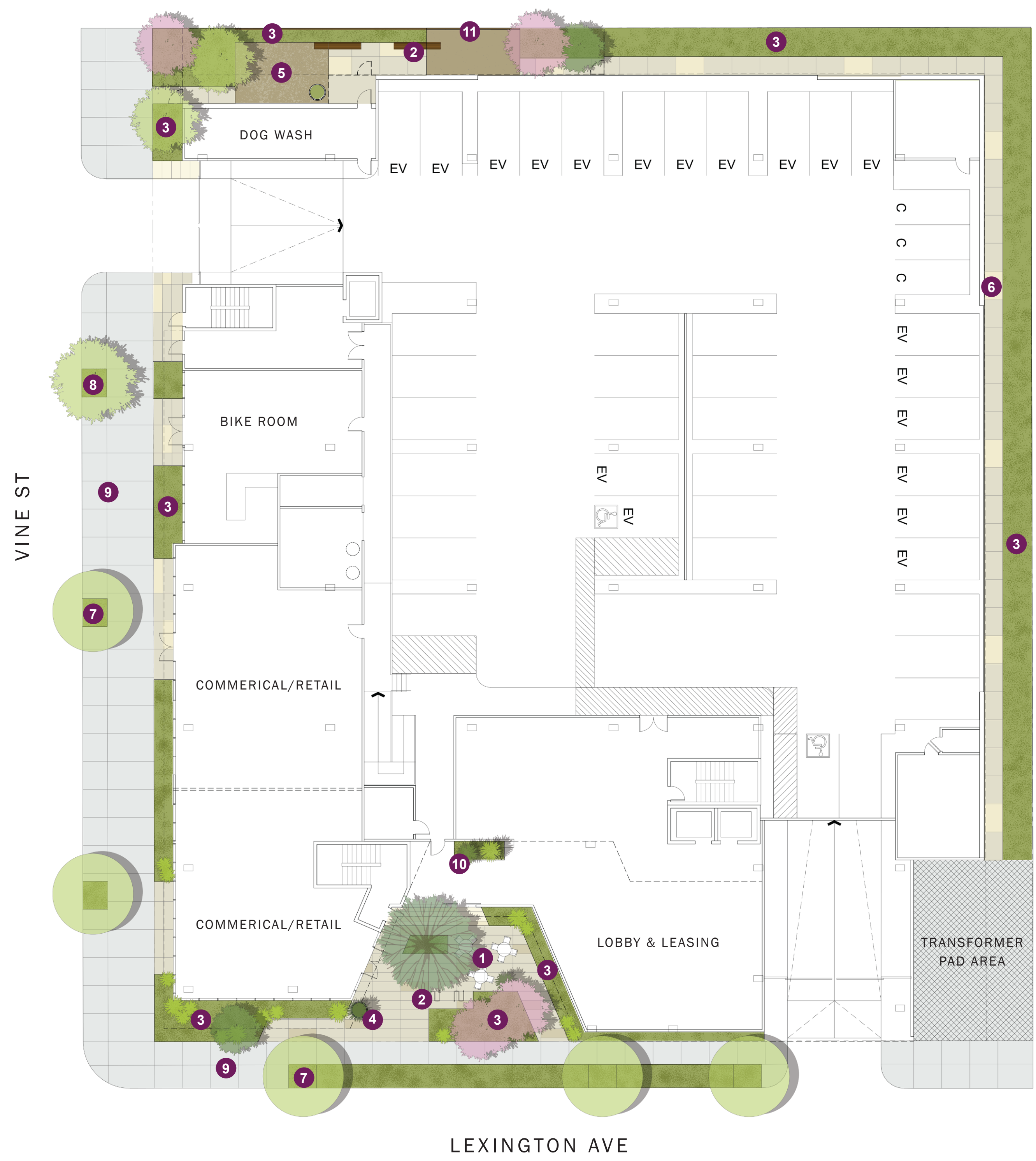

LEGEND

- 1 Entry Plaza
- 2 Bike Parking (6 spaces)
- 3 Planting Area
- 4 Decorative Pottery
- 5 Dog Run
- 6 Maintenance Path
- 7 Existing Street Trees
- 8 Proposed Street Tree
- 9 Streetscape per City Standards
- 10 Inner Garden Planting
- 11 Wood Screen with Vines



Architecture + Planning
888.456.5849
ktgy.com



Grubb
4601 Park Road, Suite 450
Charlotte, NC 28209

1200 VINE STREET
LOS ANGELES, CA #2021-1034

CONCEPTUAL DESIGN
APRIL 11, 2023



LANDSCAPE PLAN
LEVEL 1

L1-1

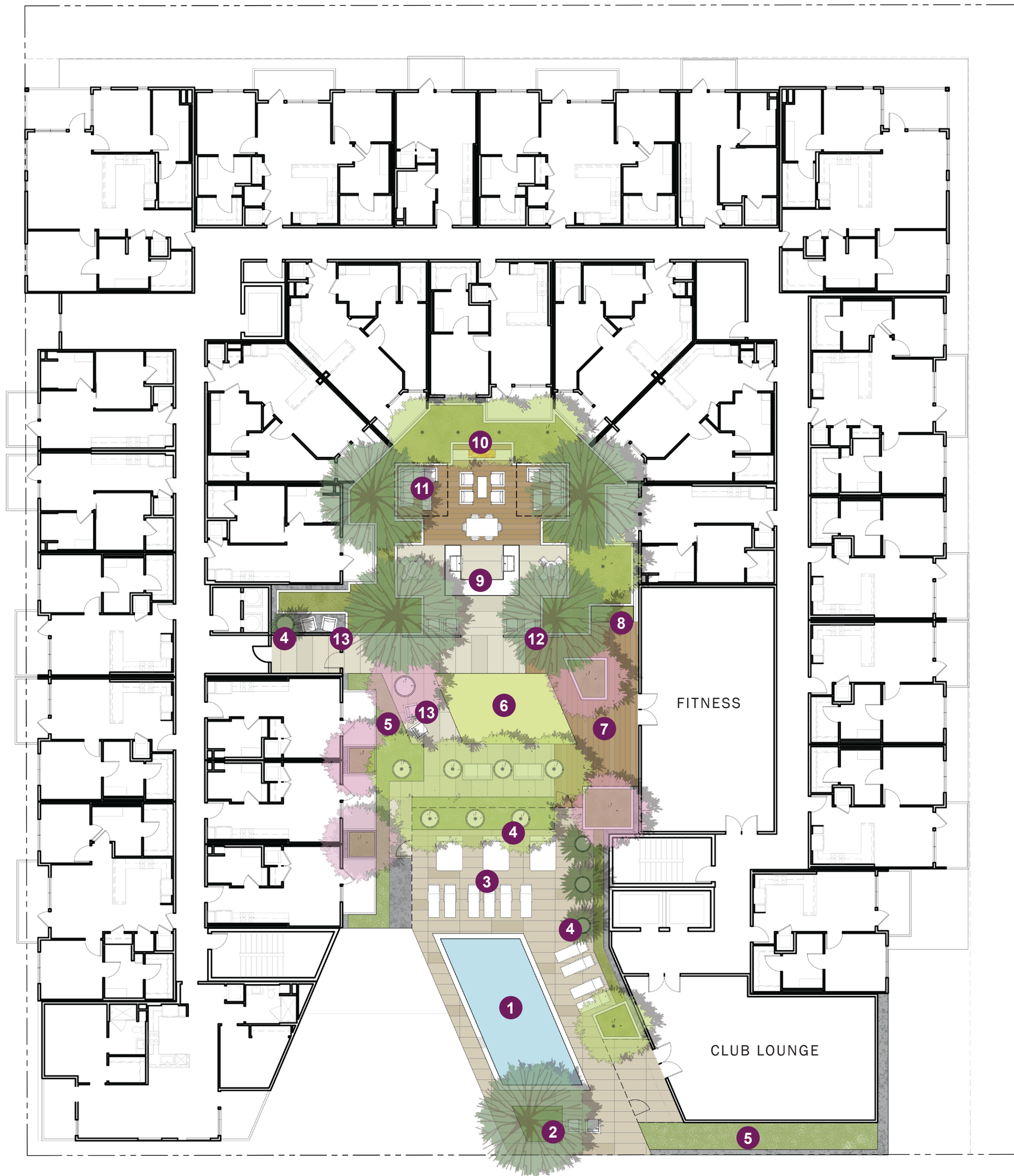

LEGEND

- ① Pool
- ② Flush Planter
- ③ Pool Deck
- ④ Decorative Pottery
- ⑤ Live Roof Planting
- ⑥ Lawn
- ⑦ Fitness Spillout Space
- ⑧ Juice Bar/Countertop
- ⑨ Outdoor Kitchen
- ⑩ Fire Feature
- ⑪ Cabana Rooms
- ⑫ Garden Screens
- ⑬ Seating Gardens



Architecture + Planning
888.456.5849
ktgy.com

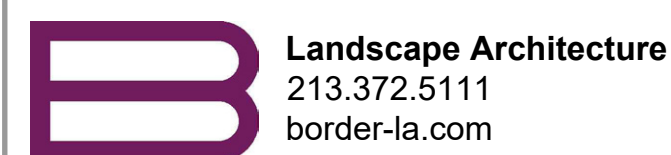

Grubb
4601 Park Road, Suite 450
Charlotte, NC 28209

1200 VINE STREET
LOS ANGELES, CA #2021-1034

CONCEPTUAL DESIGN
APRIL 11, 2023



LANDSCAPE PLAN
LEVEL 3

L1-2



LEGEND

- 1 Fiberglass Planters
- 2 Live Roof Planting
- 3 Yoga/Sun Deck
- 4 Fire Feature
- 5 Stepping Stones
- 6 Trellis
- 7 Amenity Room Terrace
- 8 Outdoor Kitchen
- 9 Decorative Gravel
- 10 Countertop w/ Bar Seating
- 11 Decorative Pottery



Architecture + Planning
888.456.5849
ktgy.com

B Landscape Architecture
213.372.5111
border-la.com

Grubb
4601 Park Road, Suite 450
Charlotte, NC 28209

1200 VINE STREET
LOS ANGELES, CA #2021-1034

CONCEPTUAL DESIGN
APRIL 11, 2023



LANDSCAPE PLAN
LEVEL 7

L1-3

**Exhibit B –
Environmental Documents
(ENV-2022-7048-CE)**



Categorical Exemption

1200 Vine Project

Environmental Case Number: ENV-2022-7048-CE

Related Case Number: CPC-2022-7047-CU-DB-SPR-HCA

Project Location: 1200, 1204, 1214, 1218 N. Vine Street and 6245, 6247 W. Lexington Avenue, Los Angeles, CA 90038

Community Plan Area: Hollywood Community Plan

Council District: 13

Project Description: The Project Site is located on the northeast corner of Vine Street and Lexington Avenue, in the Hollywood Community Plan of the City of Los Angeles, 90038 in the County of Los Angeles. The Project Site contains two buildings with a total of 27,011 square feet. Both buildings are vacant. The Project would construct a new mixed-use 8-story building with 153 residential dwelling units and 7,000 square feet of ground floor commercial (assuming a high-turnover sit-down restaurant with 235 seats).

Discretionary entitlements required to implement the Project will include, but are not necessarily limited to, the following: **Density Bonus (DB)**, pursuant to LAMC Section 12.22 A.25(g)(3), approval of a Density Bonus Application for a project having 153 residential dwelling units, including 18 units reserved for Very Low Income households (17% of the base units, or 11 percent of the total number of units), with the following Off-Menu Incentives: **Off-Menu Incentive**, for an increase in the Floor Area Ratio (FAR) to 3.51:1 in lieu of the otherwise allowable maximum of 0.5:1 in the C2-1D Zone, as restricted by Ordinance Number 164,692; **Off-Menu Incentive**, for a decrease in the required rear yard to allow 10 feet in lieu of 20 feet required in the C2-1D Zone; and **Off-Menu Incentive**, for a decrease in the required side yard to allow 0 feet in lieu of 10 feet required in the C2-1D Zone. **Conditional Use permit (CU)**, pursuant to LAMC Section 12.24 U.26, for a Conditional Use permit to allow a 15 percent increase in density beyond the maximum 35 percent permitted in LAMC Section 12.22 A.25, for a total increase in density of 50% to provide a total of 153 residential dwelling units, setting aside 17% of its base density units for Very Low Income Households. **Site Plan Review (SPR)** pursuant to LAMC Section 16.05, for a development project that results in an increase of 50 or more dwelling units and/or guest rooms. **Class 32 Categorical Exemption**, pursuant to the State of California Environmental Quality Act and CEQA Guidelines, Section 15300. Other discretionary and ministerial permits and approvals that may be deemed necessary, including, but not limited to, temporary street closure permits, grading permits, haul route approval and permits, excavation permits, foundation permits, building permits, and sign permits.

PREPARED FOR:

The City of Los Angeles
Department of Los Angeles City
Planning

PREPARED BY:

CAJA Environmental Services, LLC
9410 Topanga Canyon Blvd., Suite 101,
Chatsworth, CA 91311

APPLICANT:

Vine Street Los Angeles Apartments,
LLC
4601 Park Road, Suite 450,
Charlotte, NC 28209

January 2023

Table of Contents

<u>Section</u>	<u>Page</u>
1 Project Description.....	1-1
2 Environmental Analysis	2-1
1 Regulatory Framework.....	2-1
2 CCR Section 15332(a): General Plan Consistency	2-3
3 CCR Section 15332(b): Within City Limits and Less than 5 Acres	2-20
4 CCR Section 15332(c): No Value for Endangered Species.....	2-21
5 CCR Section 15332(d): Traffic.....	2-24
6 CCR Section 15332(d): Noise.....	2-30
7 CCR Section 15332(d): Air Quality	2-48
8 CCR Section 15332(d): Water Quality	2-82
9 CCR Section 15332(e): Public Services and Utilities.....	2-93
10 CCR Section 15300.2(a): Location	2-110
11 CCR Section 15300.2(b): Cumulative Impact.....	2-111
12 CCR Section 15300.2(c): Significant Effect	2-125
13 CCR Section 15300.2(d): Scenic Highways	2-127
14 CCR Section 15300.2(e): Hazardous Waste Sites	2-128
15 CCR Section 15300.2(f): Historical Resources.....	2-129

<u>Figures</u>	<u>Page</u>
1-1 Regional Map.....	1-5
1-2 Aerial Map.....	1-6
1-3 Site Plan	1-12
6-1 Noise Measurement Locations	2-37
6-2 Construction Noise Sound Contours	2-41
11-1 Related Projects Map	2-112
11-2 Construction Noise Contours from Cumulative Development	2-116

<u>Tables</u>	<u>Page</u>
1-1 Public Transit.....	1-8
1-2 Project Site	1-9
1-3 Existing Buildings.....	1-10
1-4 Density.....	1-11
1-5 Floor Area	1-13
1-6 Setbacks	1-14
1-7 Open Space.....	1-15
1-8 Vehicle Parking.....	1-17

1-9	Electric Vehicle Parking	1-18
1-10	Bicycle Parking	1-18
1-11	Construction Schedule.....	1-20
2-1	General Plan Consistency Analysis.....	2-6
2-2	Community Plan Consistency Analysis	2-16
5-1	Trip Generator Estimates.....	2-26
5-2	VMT Analysis Summary	2-28
6-1	A-Weighted Decibel Scale	2-30
6-2	State of California Noise/Land Use Compatibility Matrix	2-33
6-3	Existing Noise Levels.....	2-38
6-4	Construction Schedule Assumptions	2-40
6-5	Construction Noise Impacts at Off-Site Sensitive Receptors	2-42
6-6	Construction Vehicle Trips.....	2-43
6-7	Parking Garage-Related Impacts at Off-Site Sensitive Receptors	2-45
7-1	State and National Ambient Air Quality Standards	2-49
7-2	Ambient Air Quality Data	2-62
7-3	SCAQMD Emissions Thresholds.....	2-66
7-4	Project Consistency with City of Los Angeles Air Quality Element.....	2-71
7-5	Construction Schedule Assumptions	2-74
7-6	Estimated Daily Construction Emissions	2-76
7-7	Estimated Daily Operations Emissions.....	2-77
9-1	Fire Stations.....	2-95
9-2	Estimated Student Generation	2-98
9-3	Parks and Recreation Centers.....	2-99
9-4	Los Angeles Public Libraries	2-100
9-5	Project Estimated Wastewater Generation.....	2-102
9-6	Project Estimated Water Demand	2-104
9-7	Landfill Capacity	2-107
9-8	Project Demolition and Construction Waste Generation	2-108
9-9	Project Estimated Solid Waste Generation	2-108
11-1	Related Projects Land Uses	2-112
11-2	Cumulative Construction Noise Impacts at Off-Site Sensitive Receptors	2-116
11-3	Project + Related Projects Estimated Wastewater Generation	2-122
11-4	Project + Related Projects Estimated Water Demand.....	2-123
11-5	Project + Related Projects Estimated Solid Waste Generation	2-124

Appendices

- A-1 Plans, KTGy, July 26, 2022
- A-2 Landscape Plans, Border Landscape Architecture, September 16, 2022

B Tree Evaluation Report, Arborgate Consulting, June 21, 2022

C-1 Transportation Assessment, Gibson Transportation Consulting, November 1, 2022

C-2 Approval Letter, Los Angeles Department of Transportation, December 19, 2022

D Noise Technical Modeling, DKA Planning, October 2022

E Air Quality Technical Modeling, DKA Planning, October 2022

F Water Resources Technical Report, Fuscoe Engineering, October 25, 2022

G-1 Parks Response, Los Angeles Department of Recreation and Parks, September 22, 2022

G-2 Water and Wastewater Technical Report, Fuscoe Engineering, November 29, 2022

H-1 Geotechnical Engineering Investigation, Geotechnologies, Inc., December 9, 2021

H-2 Approval Letter, Los Angeles Department of Building and Safety, July 29, 2022

Section 1

Project Description

This section is based on the following items, which is included as **Appendix A** to this CE:

A-1 Plans, KTGy, July 26, 2022

A-2 Landscape Plans, Border Landscape Architecture, September 16, 2022

1 Project Information

Project Title: 1200 Vine Project

Document Type: Class 32 Categorical Exemption (CE) for new mixed-use in-fill development (the Project)

Environmental No.: ENV-2022-7048-CE

Related Case No.: CPC-2022-7047-CU-DB-SPR-HCA

Project Location: 1200, 1204, 1214, 1218 N. Vine Street and 6245, 6247 W. Lexington Avenue, Los Angeles, CA 90038 (Project Site or Site)

Lead Agency: City of Los Angeles, Los Angeles City Planning
200 N. Spring Street, Room 763, Los Angeles, CA 90012
Stephanie Escobar, Planning Assistant
213-978-1492, stephanie.escobar@lacity.org

Applicant: Vine Street Los Angeles Apartments, LLC
4601 Park Road, Suite 450, Charlotte, NC 28209

Prepared By: CAJA Environmental Services, LLC
9410 Topanga Canyon Boulevard, Suite 101, Chatsworth, CA 91311
Seth Wulkan, Project Manager
310-469-6704, seth@ceqa-nepa.com

2 Regulatory Setting

California Environmental Quality Act (CEQA) Guidelines, Article 19 (Categorical Exemptions):

15300. CATEGORICAL EXEMPTIONS

Section 21084 of the Public Resources Code requires these Guidelines to include a list of classes of projects which have been determined not to have a significant effect on the environment and which shall, therefore, be exempt from the provisions of CEQA.

In response to that mandate, the Secretary for Resources has found that the following classes of projects listed in this article do not have a significant effect on the environment, and they are

declared to be categorically exempt from the requirement for the preparation of environmental documents.

15300.2. EXCEPTIONS

(a) *Location.* Classes 3, 4, 5, 6, and 11 are qualified by consideration of where the project is to be located – a project that is ordinarily insignificant in its impact on the environment may in a particularly sensitive environment be significant. Therefore, these classes are considered to apply all instances, except where the project may impact on an environmental resource of hazardous or critical concern where designated, precisely mapped, and officially adopted pursuant to law by federal, state, or local agencies.

(b) *Cumulative Impact.* All exemptions for these classes are inapplicable when the cumulative impact of successive projects of the same type in the same place, over time is significant.

(c) *Significant Effect.* A categorical exemption shall not be used for an activity where there is a reasonable possibility that the activity will have a significant effect on the environment due to unusual circumstances.

(d) *Scenic Highways.* A categorical exemption shall not be used for a project which may result in damage to scenic resources, including but not limited to, trees, historic buildings, rock outcroppings, or similar resources, within a highway officially designated as a state scenic highway. This does not apply to improvements which are required as mitigation by an adopted negative declaration or certified EIR.

(e) *Hazardous Waste Sites.* A categorical exemption shall not be used for a project located on a site which is included on any list compiled pursuant to Section 65962.5 of the Government Code.

(f) *Historical Resources.* A categorical exemption shall not be used for a project which may cause a substantial adverse change in the significance of a historical resource.

15332. IN-FILL DEVELOPMENT PROJECTS

Class 32 consists of projects characterized as in-fill development meeting the conditions described in this section.

(a) *The project is consistent with the applicable general plan designation and all applicable general plan policies as well as with applicable zoning designation and regulations.*

(b) *The proposed development occurs within city limits on a project site of no more than five acres substantially surrounded by urban uses.*

(c) *The project site has no value as habitat for endangered, rare or threatened species.*

(d) *Approval of the project would not result in any significant effects relating to traffic, noise, air quality, or water quality.*

(e) *The site can be adequately served by all required utilities and public services.*

3 Environmental Setting

3.1 Project Location

The Project Site is located on the northeast corner of Vine Street and Lexington Avenue, in the Hollywood Community Plan of the City of Los Angeles (City), 90038 in the County of Los Angeles (County).

The Site is located approximately 4.75 miles northwest of Downtown Los Angeles and 11.5 miles northeast of the Pacific Ocean.

See **Figure 1-1, Regional Map**, for the location of the Project within the context of the City.

See **Figure 1-2, Aerial Map**, for an aerial view of the Site and the immediate surrounding area.

3.2 Surrounding Land Uses

The zoning of the Site and surrounding area is shown below.

North adjacent to the Site is a 2-story office building (currently occupied by Los Angeles County Department of Mental Health, Hollywood Mental Health Center, 1224 Vine Street). This area is zoned C2-1D.

South across Lexington Avenue is a fast food restaurant with drive-thru and surface parking lot (currently occupied by a Taco Bell, 6254 Lexington Avenue). This area is zoned C2-1D.

Southeast across Lexington Avenue are two 2-story residential buildings (6230, 6240 Lexington Avenue). This area is zoned RD1.5-1XL.

West across Vine Street is a 1-story banquet and event facility (currently occupied by the Taglyan Complex, 1201 Vine Street) and a vacant lot. This area is zoned C2-1D

Southwest across Vine Street and Lexington Avenue is a 2-story vacant commercial building (1161 Vine Street) and a 2-story school building and outdoor play area (currently occupied by the Early Head Start, 1147 Vine Street). This area is zoned C2-1D

East adjacent to the Site are two 2-story residential buildings (6232-6238 La Mirada Avenue and 6231-6239 Lexington Avenue). This area is zoned RD1.5-1XL.

The nearest residential uses:

- Multi-family buildings located at 6232-6238 La Mirada Avenue and 6231-6239 Lexington Avenue, 5 feet east of the Site.

The nearest schools:

- Early Head Start, 1147 Lexington Avenue, 160 feet southwest of the Site.
- Episcopal School of Los Angeles, 6235 Santa Monica Boulevard, 585 feet southwest of the

Site.

- Vine Street Elementary School, 955 Vine Street, 1,350 feet southwest of the Site.

The nearest historic resources:^{1,2}

- None

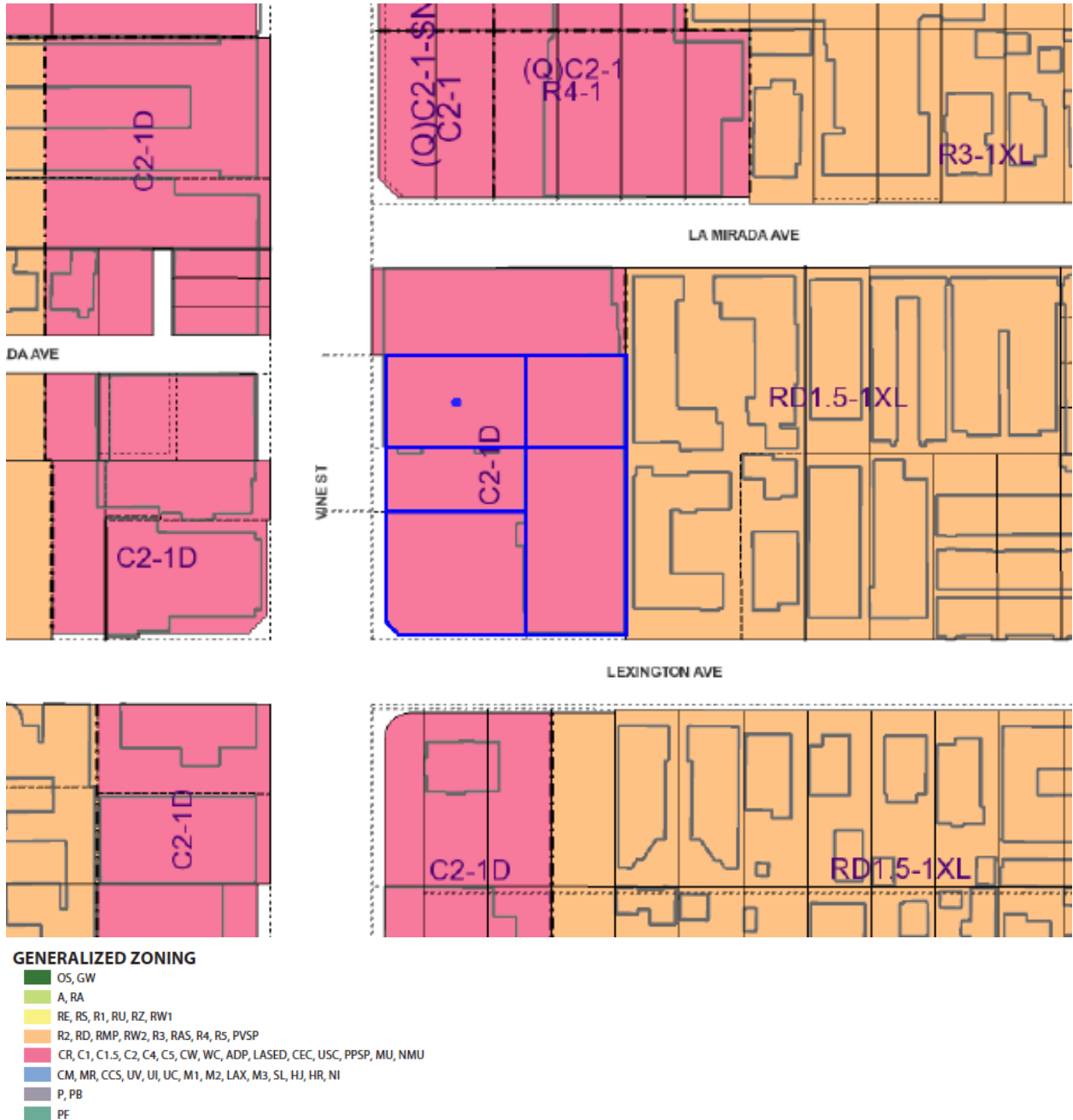

¹ NavigateLA, Historic-Cultural Monuments layer: <https://navigatea.lacity.org/navigatea>, and HistoricPlacesLA: <http://historicplacesla.org/map>, accessed July 8, 2022.

² SurveyLA: <https://planning.lacity.org/preservation-design/historic-resources-survey>

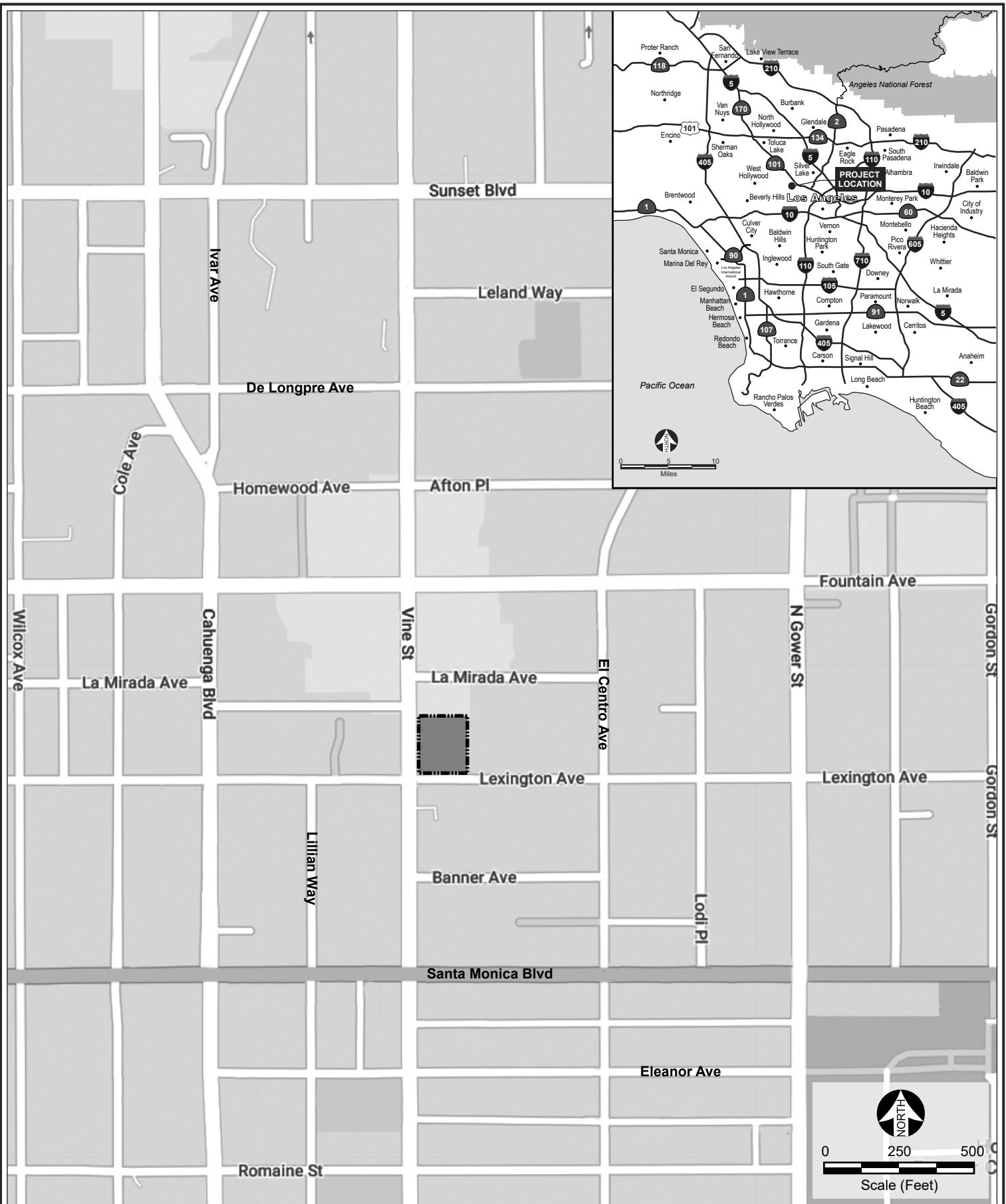

Legend

 Project Site

Source: Google Maps 2022.

Figure 1
Regional Location Map



Legend

 Project Site

Source: Google Maps 2022.

Figure 2
Aerial Map

3.3 Regional and Local Access

Regional access is provided by:

- US-101 (Hollywood) Freeway, 3,800 feet northeast of the Site

Local access is provided by:³

- Vine Street (Avenue II in the Mobility Plan 2035), adjacent west of the Site
- Lexington Avenue (Local Street Standard), adjacent south of the Site
- La Mirada Avenue (Local Street Standard), 80 feet north of the Site
- El Centro Avenue (Local Street Standard), 410 feet east of the Site
- Santa Monica Boulevard (Modified Avenue I), 665 feet south of the Site
- Fountain Avenue (Collector), 375 feet north of the Site
- Cahuenga Boulevard (Modified Avenue II), 675 feet west of the Site

3.4 Public Bicycle Facilities

There is a Metro Bike Share station, located at Vine Street and Fountain Avenue, 375 feet north of the Site.⁴

The following bicycle-friendly streets are nearby:⁵

- Vine Street, adjacent west of the Site
- Fountain Avenue, 375 feet north of the Site

3.5 Pedestrian Facilities

There are sidewalks along the Project Site's west side on Vine Street and south side on Lexington Avenue.

Striped crosswalks are provided at all legs of the nearest signalized intersection:

- Vine Street and Lexington Avenue, southwest of the Site

³ NavigateLA, Mobility Plan 2035: <https://navigate-la.org/navigate-la/>, accessed July 8, 2022.

⁴ Metro Bike Share: <https://bikeshare.metro.net/stations/>, accessed July 8, 2022.

⁵ According to LADOT's Bike Program, Bicycle Friendly Streets (BFS) facilities parallel major corridors and provide a calmer, safer alternative for bicyclists of all ages and skill levels. BFS are multi-modal streets, which means that they accommodate all neighborhood users from cars, to bikes, to pedestrians. <https://ladotbikeblog.wordpress.com/bfs/>

3.6 Public Transit

The Site is within a High Quality Transit Area (HQTA),⁶ which are areas within one-half mile of a high quality transit corridor, which is a corridor with fixed route bus service with service intervals no longer than 15 minutes during peak commute hours.⁷

Los Angeles County Metropolitan Transportation Authority (Metro)⁸ and Los Angeles Department of Transportation (LADOT)⁹ operates public transit in the area, as shown in **Table 1-1, Public Transit**.

**Table 1-1
Public Transit**

Line	Type	Direction	Stop	Distance to Site	Service (Peak Period Average Headways)
Metro					
210	Bus	North-south	Vine / Lexington	Adjacent west	10 minutes
4	Bus	East-west	Vine / Santa Monica	680 feet south	8 minutes
B (Red)	Subway	North-south	Hollywood / Vine	2,950 feet north	15 minutes
LADOT DASH					
Hollywood	Bus	East-west	Vine / Fountain	430 feet north	30 minutes
Hollywood / Wilshire	Bus	North-south	Gower / Lexington	1,060 feet east	30 minutes
Measurement from Site boundary to nearest station or stop point. Metro 210 schedule (October 23, 2022): https://www.metro.net/riding/schedules/?line=210-13167 Metro 4 schedule (October 23, 2022): https://www.metro.net/riding/schedules/?line=4-13167 Metro B schedule (December 11, 2022): https://www.metro.net/riding/schedules/?line=802 LADOT Hollywood (August 3, 2020): https://www.ladottransit.com/dash/routes/hollywood/hollywood.html LADOT H/W (July 31, 2021): https://www.ladottransit.com/dash/routes/hollywoodwilshire/hollywoodwilshire.html					

3.7 Planning and Zoning

Table 1-2, Project Site, lists the Site's APNs, zoning and General Plan land use designation:

- C2-1D (Commercial zone in Height District 1 with a Development Limitation) and Highway Oriented Commercial designation.¹⁰

The D Limitation is:¹¹

1. *The total floor area contained in all buildings on a lot shall not exceed one half (0.5)*

⁶ SCAG, HQTA 2016 based on the 2020-2045 RTP/SCS: <https://gisdata-scag.opendata.arcgis.com/datasets/high-quality-transit-areas-hqta-2016-scag-region?geometry=-121.570%2C33.364%2C-114.731%2C34.954>, accessed July 8, 2022.

⁷ SCAG, Connect SoCal, Active Transportation Technical Report, page 26: https://scag.ca.gov/sites/main/files/file-attachments/0903fconnectsocial_active-transportation.pdf?1606001530, accessed July 8, 2022.

⁸ Metro System Map, Westside/Central Map: <https://www.metro.net/riding/guide/system-maps/>, accessed July 8, 2022.

⁹ LADOT System Map: <https://www.ladottransit.com/dash/>, accessed June 20, 2022.

¹⁰ Los Angeles Zoning Summary: <https://planning.lacity.org/zoning/regulations-summary>

¹¹ Ordinance No. 164,692, May 16, 1989: <https://planning.lacity.org/pdiscaseinfo/document/ODMxMw0/6d0d2d25-0f15-4c7d-b0c2-0a119627b1eb/ord>

times the buildable area of the lot.

**Table 1-2
Project Site**

Address	Lot	APN	Size (sf)	Zone	Land Use
6245, 6247 W. Lexington Avenue	3	5534-002-023	11,309.9	C2-1D	Highway Oriented Commercial
1200, 1204 N. Vine Street	4		10,417.6		
None	5		5,509.0		
1214, 1218 N. Vine Street	6	5534-002-018	7,934.0		
None	8		5,616.0		
Source: Zone Information & Map Access System (ZIMAS): http://zimas.lacity.org , July 2022.					

The Project Site also is subject to the following zoning-related items:

- 2374 State Enterprise Zone: Los Angeles
- ZI-2433 Revised Hollywood Community Plan Injunction
- ZI-2498 Local Emergency Temporary Regulations - Time Limits and Parking Relief - LAMC 16.02.1
- ZI-2452 Transit Priority Area in the City of Los Angeles

The Project Site is located 665 feet north from a qualified Major Transit Stop at the intersection of Santa Monica Boulevard and Vine Street, which is served by Metro bus line 4 running east-west and Metro bus line 210 running north-south. As shown in **Table 1-1** above, both lines have an average service interval of 15 minutes or less.¹²

The Project Site is not within a Special Grading Area.¹³

The Project Site is not within a Methane Hazard Site.¹⁴

The Project Site is in the Hollywood Community Plan, which designates the site as Highway Oriented Commercial. The Hollywood Community Plan is undergoing a Community Plan Update (Update) and is currently in the adoption phase. The Update has been approved by the City Planning Commission which referred the Update to the City Council for adoption on August 19, 2021. The upcoming steps to complete adoption of the Update are receiving the recommendations for approval from the Los Angeles City Council's Planning and Land Use Management (PLUM) Committee, and then the final approval from the full City Council.¹⁵ Adoption is anticipated in 2023.

¹² Major Transit Stop is a site containing a rail station or the intersection of two or more bus routes with a service interval of 15 minutes or less during the morning and afternoon peak commute periods. The stations or bus routes may be existing, under construction or included in the most recent Southern California Association of Governments (SCAG) Regional Transportation Plan (RTP).

¹³ Zone Information & Map Access System (ZIMAS): <http://zimas.lacity.org>, June 20, 2022.

¹⁴ Zone Information & Map Access System (ZIMAS): <http://zimas.lacity.org>, June 20, 2022.

¹⁵ Hollywood Community Plan Update: <https://planning.lacity.org/plans-policies/community-plan-update/hollywood-community-plan-update#about>

3.8 Existing Conditions

The lot area is 40,786 square feet (0.936 acres).¹⁶ In the C2 zone, the buildable area equals the lot area.

The Project Site contains two one-story commercial buildings with a total of 27,011 square feet, as listed in **Table 1-3, Existing Buildings**.

Both buildings are vacant. They were formerly used for Goodwill Store and Dollar Store but have not been occupied for at least one year.

There is also an approximately 16,000 square foot¹⁷ surface parking lot, fencing and a pole sign.

The Project will remove all existing uses and demolish all existing buildings.

**Table 1-3
Existing Buildings**

Address	Use	Stories	Size (sf)
6245-6247 Lexington	Vacant	1	13,475
1214-118 Vine	Vacant	1	13,536
Total			27,011
Source: Zone Information & Map Access System (ZIMAS): http://zimas.lacity.org , July 2022.			

The Site is not listed in HistoricPlacesLA¹⁸ and not listed in SurveyLA.¹⁹

There are 9 street trees on the sidewalk (4 jacarandas on Vine Street and 5 pink trumpet trees on Lexington Avenue). There are 3 onsite palm trees on the southwest corner of the parking lot.²⁰ None of the trees constitute a protected tree²¹ or shrub.²²

4. Project Description

4.1 Project Overview

The Project would construct a new mixed-use 8-story building with 153 residential dwelling units

¹⁶ [Plans](#), KTGy, July 26, 2022.

¹⁷ Google Maps approximate area.

¹⁸ Los Angeles Historic Places: <http://historicplacesla.org/map>, accessed July 8, 2022.

¹⁹ SurveyLA: <https://planning.lacity.org/preservation-design/historic-resources-survey>, accessed July 8, 2022.

²⁰ [Tree Evaluation Report](#), Arborgate Consulting, June 21, 2022.

²¹ LAMC Section 46.01: "PROTECTED TREE" means any of the following Southern California native tree species which measures four inches or more in cumulative diameter, four and one-half feet above the ground level at the base of the tree: (a) Oak tree including Valley Oak (*Quercus lobata*) and California Live Oak (*Quercus agrifolia*), or any other tree of the oak genus indigenous to California but excluding the Scrub Oak (*Quercus dumosa*). (b) Southern California Black Walnut (*Juglans californica* var. *californica*) (c) Western Sycamore (*Platanus racemosa*) (d) California Bay (*Umbellularia californica*) This definition shall not include any tree grown or held for sale by a licensed nursery, or trees planted or grown as a part of a tree planting program.

²² Effective February 4, 2021 in Ordinance No 186,873, the City added Mexican elderberry and toyon shrubs to the list of protected species.

and 7,000 square feet of ground floor commercial (assuming a high-turnover sit-down restaurant²³ with 235 seats²⁴).

The Project would include 93 parking spaces as required by the Los Angeles Municipal Code (LAMC) and applicable Density Bonus incentives. Parking is located in two above grade levels wrapped with commercial use on the ground floor and residential units on the second floor.

The Project includes 21 studio units, 89 one-bedroom units, and 43 two-bedroom units.

The building will contain 5 levels of Type IIIA Wood (residential units on the fourth, fifth, sixth, seventh, and eighth levels) over 3 levels of Type IA Concrete (one ground floor level of parking and commercial use; parking and residential amenities on the second level; and residential units on the third level).

See **Figure 1-3, First Floor Plan**, for the ground level of the Project.

4.1.1 Density

See **Table 1-4** for the density calculation. Pursuant to the City’s General Plan and LAMC Sections 12.14 A.4, 12.13.5 A.1, and 12.11 C.4, the maximum residential density within the C2 zone is generally one dwelling unit for every 400 square feet of lot area.

The lot area is 40,786 square feet. The Project therefore provides a base density of 102 units per the LAMC.

The Project is requesting a Density Bonus off-menu incentive pursuant to LAMC Section 12.22.A.25 to allow an increase in number of dwelling units by 50%, or 51 units. This would allow a total of 153 units.

The Project proposes 153 units, of which 17% of the base units ($102 \times 17\% = 18$ units) would be reserved for Very Low Income (VLI) households. The remaining 135 units will be market-rate.

**Table 1-4
Density**

Zone	Site Area	LAMC Density		Density Bonus		Provided
		Rate	Base	Incentive	Max	
C2	40,786 sf	1 unit / 400 sf	102 units	+50% (+51)	153 units	153 units
Plans, KTG, July 26, 2022.						

²³ [Transportation Assessment](#), Gibson Transportation Consulting, November 2, 2022.

²⁴ Assumes 50% of Restaurant Space Will be Usable Seating Area and 15 Square Feet per Seat.

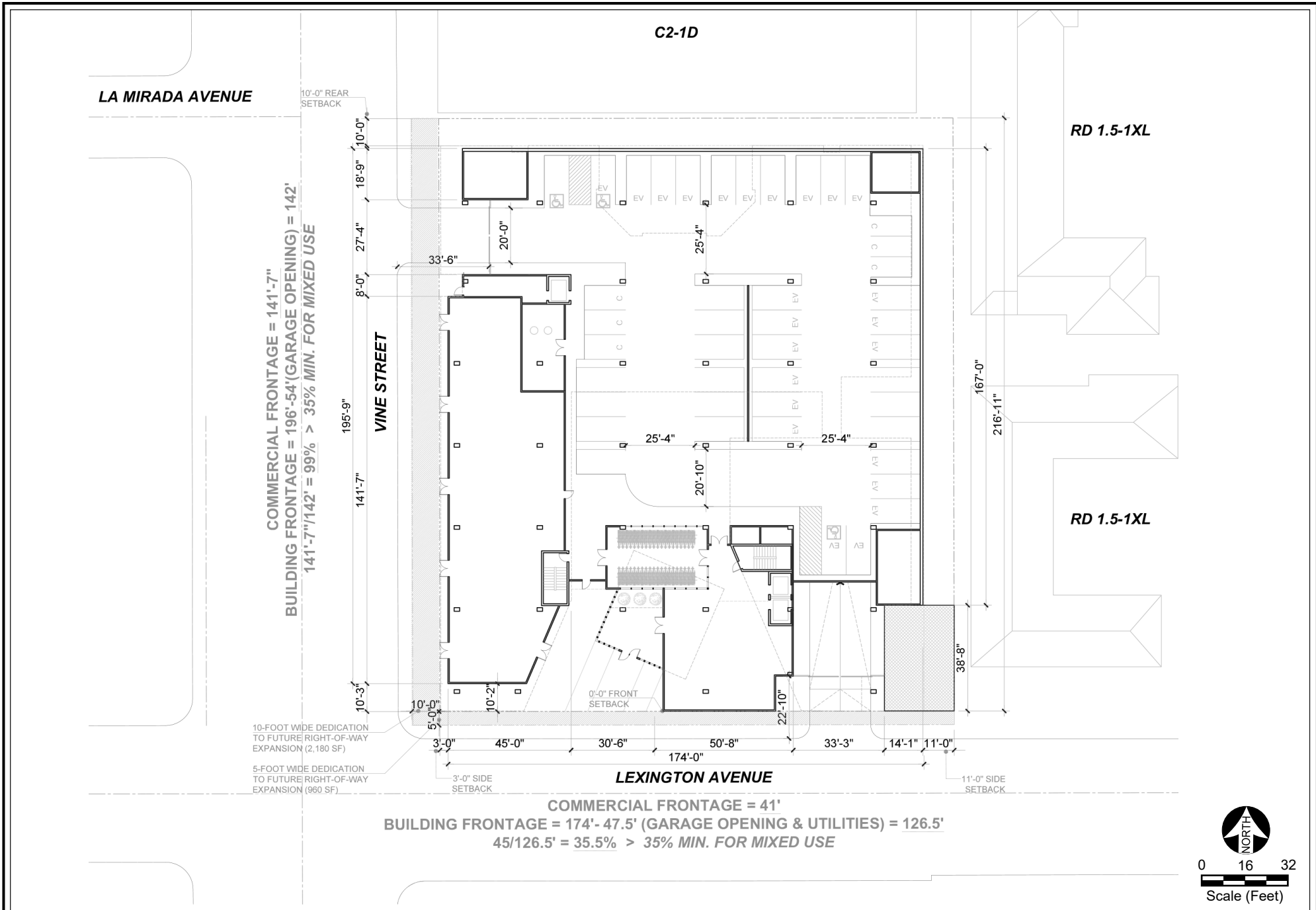

4.1.2 Floor Area

See **Table 1-5** for the floor area and floor area ratio (FAR). Per LAMC Section 12.03, Buildable Area includes, “All that portion of a lot located within the proper zone for the proposed main building, excluding those portions of the lot which must be reserved for yard spaces, building line setback space, or which may only be used for accessory buildings or uses.”

Under the LAMC, the FAR is limited to 0.5:1 due to the D Limitation as restricted by Ordinance Number 164,692. With a buildable area of 40,786 square feet, the floor area is limited to 20,393 square feet.

The Project is requesting a Density Bonus off-menu incentive pursuant to LAMC Section 12.22.A.25 for an increase in the FAR to 3.51:1 in lieu of the otherwise allowable maximum of 0.5:1 in the C2-1 Zone, as restricted by Ordinance Number 164,692.

The Hollywood Community Plan update would alter the underlying zoning to add a “Q” condition raising the base FAR from 0.5:1 to 1.5:1 and placing the Site under the Hollywood Community Plan Implementation Overlay (CPIO) that will provide for substantial height and FAR for projects providing affordable units.

The Project would include 143,295 square feet of floor area and a 3.51:1 FAR. Of this total, 136,295 square feet is residential floor area and 7,000 square feet is commercial. The commercial floor area is located at the ground floor of the Project.

**Table 1-5
Floor Area**

Zone	Buildable Area	LAMC Base		Density Bonus		Provided	
		FAR	Floor Area	FAR	Floor Area	FAR	Floor Area
C2-1D	40,786 sf	0.5:1	20,393 sf	3.51:1	143,295	3.51:1	143,295
[Q]C2-2D-CPIO	40,786 sf	1.5:1	61,179 sf	3:1	122,358 sf	3.51:1	143,295
Plans, KTG, July 26, 2022.							

4.1.3 Height

Pursuant to LAMC Section 12.21.1.B.3(a), rooftop structures, equipment and improvements may exceed the maximum building height when authorized, provided the structure, equipment or improvement is screened from public view using non-reflective materials or otherwise made compatible with the overall design of the building.

Pursuant to LAMC Section 12.21.1.B.3, chimney, exhaust ducts, solar water heaters, or any roof structure housing stairways, elevators or ventilation fans may also exceed the building height limit by up to five feet, but are not required to provide a setback from the perimeter of the roof. Where height is limited to seventy-five (75) feet, roof structures for the housing of elevators and stairways may exceed the building height limit by up to twenty (20) feet in height.

The LAMC does not impose a maximum building height limit for height district 1 in the C2 zone.

The Project proposes a building of 8-stories with a total height of 88'-6" feet.

4.1.4 Setbacks

See **Table 1-6** for the setbacks. In the C2, C4, and C5 zones, no front yards are required. No side or rear yards are required for commercial uses.

The Project is requesting a Density Bonus off-menu incentive pursuant to LAMC Section 12.22.A.25 for a decrease in the required rear yard to allow 10 feet in lieu of 20 feet required in the C2-1D Zone and for a decrease in the required side yard along Vine Street to allow 0 feet in lieu of the otherwise required 10 feet required in the C2-1D Zone.

The Project includes 11 foot side (east side), 0 foot side (Vine Street), and 10 foot rear yards at the first residential levels.

**Table 1-6
Setbacks**

Location	Required per LAMC	Provided
Front (Lexington)	0 feet	0 feet
Side (Vine)	10 feet	0 feet
Side (east)	0 ft. (commercial) 11 ft. (residential)	11 ft. (residential)
Rear (abutting)	0 ft. (commercial) 20 ft. (residential)	10 ft. (residential)
Per Mixed Use Exemption From LAMC Section 12.22.A.18 Plans, KTG, July 26, 2022.		

4.2 Design and Architecture

See **Appendix A** of this CE for floor plans, elevations, sections, and renderings. The Project has been designed as an integrated single structure with articulation and variation consistent with applicable City design guidance. Parking spaces within the building (ground and upper levels) and residential units located within the building have been integrated into the overall architectural theme of the Project.

The building's ground level will incorporate pedestrian scale uses and design, with a street fronting commercial storefront along with the residential building entrance all with floor to ceiling glazing. In addition, the building's proposed design, architecturally differentiates the base of the building from the residential above by including horizontal breaks in material and colored elements.

The upper residential portions of the building incorporate varied articulation including recessed balconies.

The Project is designed with a façade that utilizes a variety of materials, including metal, cement panel and plastering, and glass in order to add visual interest through different textures and colors. This variation, along with insets and offsets, and street-facing residential window contrasted with storefront glazing at the ground floor, separates the residential portions of the building from the commercial, avoids a dull or repetitive façade, and contributes to neighborhood safety by activating the ground floor and putting more “eyes on the street.”

The building provides volume articulation with carved out sections that break down the massing and allow light and air into the building. The ground floor has glass openings that provide a pedestrian-friendly experience for Project residents and the public. Ground floor commercial activates the street.

The building’s southern-facing façade is indented/cut-away above the second level to provide an interior courtyard space and allow light and air to enter the interior-facing units. This third floor courtyard space would include a pool deck and open space.

The building provides façade treatments with balconies that highlight the residential nature of the building. All sides of the proposed building are articulated with colored elements, glass and metal, windows, and inset and offset architectural elements to create visual interest. Overall variation in building appearance is created with the use of various materials, windows of different widths, and balconies, the landscaped ground floor, and the transition of the first floor to upper levels.

Rooftop equipment will be set back from the roof parapet edge and appropriately screened from public view.

The Project is designed to minimize the visual impact of building mechanics and maintenance areas. Electrical rooms, storage rooms, and trash and recycling areas, are located within the building and are not visible from surrounding public streets and public view.

The Project Site is located in an urbanized and fully developed portion of the City. The built environment is characterized by a variety of architectural styles, age of buildings, type of developments, and size.

4.3 Open Space

Table 1-7, Open Space, provides the amount of required open space under the LAMC and the open space proposed to be provided by the Project.

The Project would provide 21,569 square feet through courtyards, pool deck, indoor amenities, roof decks, and balconies.

**Table 1-7
Open Space**

Use	Quantity	Rate	Total (sf)
Required			
< 3 habitable rooms	21 units	100 sf / unit	2,100
= 3 habitable rooms	89 units	125 sf / unit	8,900
> 3 habitable rooms	43 units	175 sf / unit	5,375
Total			16,375
Provided			
Common and open to the sky	Outdoor Deck Level 1		1,700
	Outdoor Deck Level 3		6,255
	Roof Deck 1		870
	Roof Deck 2		1,000
	Subtotal		9,825
Common and indoor	Lobby Level 1		564

	Mezzanine Level 2	800
	Lounge Level 3	1,000
	Fitness Level 3	1,000
	Club Room Level 8	730
	Subtotal	4,094
Private	Balconies (153 x 50 sf)	7,650
	Total	21,569
<p>Per LAMC 12.21.G.2</p> <p>Habitable Room - An enclosed subdivision in a residential building commonly used for living purposes, but not including any lobby, hall, closet, storage space, water closet, bath, toilet, slop sink, general utility room or service porch. A recess from a room or an alcove (other than a dining area) having 50 square feet or more of floor area and so located that it could be partitioned off to form a habitable room, shall be considered a habitable room.</p> <p>For the purpose of applying the open space requirements of Section 12.21 G., a kitchen as defined herein shall not be considered a habitable room.</p> <p>A studio and 1-bedroom units have less than 3 habitable rooms. A 2-bedroom has 3 habitable rooms.</p> <p><u>Plans</u>, KTGy, July 26, 2022.</p>		

4.4 Landscaping

Per LAMC Section 12.21.G.a.3, A minimum of 25 percent of the common open space area shall be planted with ground cover, shrubs or trees. At least one 24-inch box tree for every four dwelling units shall be provided on site and may include street trees in the parkway.

The Project is required to provide 25 percent of its 9,825 square feet of outdoor common open space as landscaping, or 2,456 square feet. The Project would provide 3,142 square feet of landscaped common open space.²⁵

There are a total of 9 street trees along the sidewalk of Vine Street and Lexington Avenue. Up to 9 trees would be removed for the proposed driveways. Any tree removal will comply with the City's Tree Replacement Program (including Urban Forestry Division, Bureau of Street Services for the street trees). The City may require a replacement ratio of 2:1. Therefore, the removal of 9 trees would require 18 trees.

The Project would be required to provide at least 39 trees (153 units / 4). The Project would provide 39 trees on the ground level, Level 3 podium, and level 7:²⁶

The Project would comply with LAMC requirements for trees and landscaping.

4.5 Access and Circulation

There are three existing curb cuts at the Site, one along Lexington Avenue at the southeast corner of the Site, and two along Vine Street.

²⁵ Landscape Plans, Border Landscape Architecture, September 16, 2022.

²⁶ Landscape Plans, Border Landscape Architecture, September 16, 2022.

The southern curb cut on Vine Street would be closed. The other two curb cuts on Vine Street and Lexington Avenue will be slightly shifted to accommodate the new building.

The curb cut on Vine Street would provide two-way access (ingress and egress) to the ground level parking. The curb cut on Lexington Avenue would provide two-way access (ingress and egress) to the second level parking.

The residential use would be accessed from a residential lobby on Lexington Avenue.

The commercial use would be accessed from Vine Street.

4.6 Vehicle Parking

Table 1-8, Vehicle Parking, provides the amount of required and provided vehicle parking.

The Project is requesting parking in accordance with AB 2345 standards (Government Code Section 65915) which requires no more than 0.5 parking spaces per dwelling unit.

Additionally, the Project is in a Los Angeles State Enterprise Zone which requires 2 parking spaces for each 1,000 square feet of non-residential / retail / commercial / restaurant space.

The Project is required to provide 78 residential spaces and 14 commercial spaces for a total of 92 spaces.

The Project proposes to provide a total of 93 parking spaces (78 residential and 15 commercial spaces) in two levels (ground and level 2).

**Table 1-8
Vehicle Parking**

Use	Quantity	Required		Provided
		Rate	Amount	
Residential	21 studio	0.5 space / unit	11	78
	89 1-bedroom	0.5 space / unit	45	
	43 2-bedroom	0.5 space / unit	22	
		Subtotal	78	
Commercial	7,000 sf	1 space / 500 sf	14	15
Total			92	93
Per LAMC 12.22 A.4. Plans, KTG, July 26, 2022.				

4.6.1 Electric Vehicle Parking

According to LAMC Section 99.04.106.4.2, where multi-family dwelling units and other "R" occupancies are constructed on a building site, and parking is available, 30% of the total number of parking spaces provided, but in no case less than one space, shall be electric vehicle charging spaces (EV spaces) capable of supporting future electric vehicle supply equipment (EVSE). According to LAMC Section 99.04.106.4.4, the number of EVCS shall be 10% of the total number

of parking spaces provided for all new multi-family dwelling units, other "R" occupancies, hotels and motels.

Calculations for the required number of EV spaces and electric vehicle charging stations (EVCS) shall be rounded up to the nearest whole number. The number of EVCS can be counted towards the total number of EV spaces required for the building required per Subsections 99.04.106.4.2 and 99.04.106.4.3.1.

LAMC Section 99.05.106.5.3.3 applies to nonresidential uses and has the same 30% EVSE requirements.

LAMC Section 99.05.106.5.3.6 applies to nonresidential uses and has the same 10% EVCS requirements.

Table 1-9, Electric Vehicle Parking, provides the amount of required and provided electric vehicle parking. The Project would provide 29 EVSE spaces, of which 10 would have EVCS.

**Table 1-9
Electric Vehicle Parking**

Parking Provided	Required		Provided	
	EVSE (30%)	EVCS (10%)	EVSE	EVCS
78 residential	24	8	25	8
15 commercial	4	2	4	2
Total	28	10	29	10
EVSE - electric vehicle supply equipment. EVCS – electric vehicle charging stations. Plans, KTG Y, July 26, 2022.				

4.7 Bicycle Parking

Table 1-10, Bicycle Parking, provides the amount of required and provided bicycle parking. The Project would provide 120 bicycle parking spaces (14 short-term and 106 long-term). The long-term bicycle parking stalls will be located at the ground level.

LAMC 12.21.A.16(a) requires new projects to provide bicycle parking spaces. Short-term bicycle parking shall consist of bicycle racks that support the bicycle frame at two points. Long-term bicycle parking shall be secured from the general public and enclosed on all sides and protect bicycles from inclement weather.

**Table 1-10
Bicycle Parking**

Use	Quantity	Short-Term Spaces			Long-Term Spaces		
		Rate	Required	Provided	Rate	Required	Provided
Residential	1-25 units	1 / 10 unit	2.5	10	1 / 1 unit	25	102
	26-100 units	1 / 15 units	5.0		1 / 1.5 units	50	
	101-200 units	1 / 20 units	2.7		1 / 2 units	26.5	
	201+ units	1 / 40 units	0		1 / 4 units	0	
Commercial	7,000 sf	1 / 2,000 sf	3.5	4	1 / 2,000 sf	3.5	4

Total		13.7	14		105	106
LAMC Table 12.21 A.16 (a)(1)(i) and Ordinance No. 185,480. A minimum of two short-term bicycle parking spaces shall be provided in all cases. Per LAMC Section 12.21.A.16(b): When the application of these regulations results in the requirement of a fractional bicycle space, any fraction up to and included on-half may be disregarded, and any fraction over one-half shall be construed as requiring one bicycle parking space. Therefore the 2.5 spaces rounds down to 2 spaces. Plans, KTG, July 26, 2022.						

4.8 Lighting and Signage

Project signage would include building identification, wayfinding, and security markings. Signage would be similar to other signage in the Project's vicinity.

Exterior lighting would be shielded to reduce glare and eliminate light being cast into the night sky. Security lighting would be integrated into the overall architecture and landscaping.

The Project would also comply with LAMC lighting regulations that include approval of street lighting plans by the Bureau of Street Lighting; limited light intensity from signage to no more than three foot-candles above ambient lighting; and limited exterior lighting to no more than two foot-candles of lighting intensity or direct glare onto specified sensitive uses, under the terms of the LAMC Section 93.0117(b).

4.9 Site Security

The Project would provide a passive security program to ensure the safety of its residents, employees, and visitors. Security features to assist in crime prevention efforts and to reduce the demand for police protection services would include secured building access/design to residential areas; lighting of building entryways and areas; and possible video surveillance. The security program would include controlling access; monitoring entrances and exits of buildings; monitoring fire/life/safety systems; and security lighting.

4.10 Sustainability Features

The Project will comply with the applicable Los Angeles Green Building Code (LAGBC, 2023 version effective January 1, 2023)²⁷ and the applicable California Green Building Standards Code (CalGreen, 2022 version effective January 1, 2023).²⁸ The applicability is determined when the Project is submitted and accepted by plan check.

All building systems would meet applicable Title 24 Energy Standards. These standards would reduce energy and water usage and waste and, thereby, reduce associated greenhouse gas emissions and help minimize the impact on natural resources and infrastructure. The sustainability features to be incorporated into the Project would include, but not be limited to, WaterSense-labeled plumbing fixtures and Energy Star-labeled appliances, reduction of indoor

²⁷ City of Los Angeles Department of Building and Safety, Green Building, available at <http://ladbs.org/forms-publications/forms/green-building>, accessed on November 7, 2022.

²⁸ California Building Codes: <https://www.dgs.ca.gov/BSC/CALGreen>, accessed on November 7, 2022.

and outdoor water use, weather-based controller and drip irrigation systems, and water-efficient landscape design. In addition, the landscaping on the outdoor decks would serve to help reduce solar heat gain and facilitate possible stormwater retention on-site.

The Project would recycle and reuse building and construction materials to the maximum extent feasible.

The Project would provide EV spaces.

The Project's infill location would promote the concentration of development in an urban location with extensive infrastructure and access to public transit facilities. The Project's proximity to public transportation would reduce vehicle miles traveled for residents and visitors.

4.10.1 Solar Ready Roof

The 2019 Building Energy Efficiency Standards took effect on January 1, 2020. Low-rise multi-family buildings that do not have a photovoltaic system installed shall comply with the requirements of CCR Title 24, Part 6, Section 110.10(b) through 110.10(d).

LAMC Section 99.05.211.1 (Solar Ready Buildings) states that Projects must comply with California Energy Code Section 110.10. There are 2 exceptions: Additions having less than 2,000 square feet of new roof area and alterations.

The solar zone shall be located on the roof or overhang of the building or on the roof or overhang of another structure located within 250 feet of the building or on covered parking installed with the building project, and shall have a total area no less than 15 percent of the total roof area of the building excluding any skylight area. The solar zone requirement is applicable to the entire building, including mixed occupancy.

The roof area is 21,780 square feet. The Project is required to provide 15 percent of its roof area, or 3,267 square feet, for solar zone area. The Project would provide 3,267 square feet of solar zone.²⁹

4.11 Anticipated Construction Schedule

The estimated construction schedule is shown in **Table 1-11, Construction Schedule**.

**Table 1-11
Construction Schedule**

Phase	Schedule	Duration
Demolition	January 2, 2024 – March 29, 2024	62 days (3 months)
Grading and Excavation	April 1, 2024 – May 31, 2024	43 days (2 months)
Trenching	June 1, 2024 – July 15, 2024	30 days (1.5 months)
Construction	June 1, 2024 – July 31, 2026	535 days (26 months)
Architectural Coatings	March 2, 2026 – November 30, 2026	186 days (9 months)
<u>Demolition</u> involves removing buildings or structures.		

²⁹ Plans, KTGy, July 26, 2022.

Site Preparation involves clearing vegetation (grubbing and tree/stump removal) and removing stones and other unwanted material or debris prior to grading.

Grading involves the cut and fill of land to ensure that the proper base and slope is created for the foundation.

Trenching is associated with underground utilities.

Building Construction involves the construction of the foundation, structures and buildings.)

Paving involves the laying of concrete or asphalt such as in parking lots, roads, driveways, or sidewalks.

Architectural Coating involves the application of coatings to both the interior and exterior of buildings or structures, the painting of parking lot or parking garage striping, associated signage and curbs, and the painting of the walls or other components such as stair railings inside parking structures.

Construction schedule, including start, end, and duration dates are estimates only.

Some overlap of phasing may occur.

The analysis assumes that construction would start in 2024. In practice, construction could begin at a later time. However, using an earlier start date represents a worst-case scenario for the analysis of construction emissions, because equipment and vehicle emission factors for later years would be slightly less due to more stringent standards for in-use off-road equipment and heavy-duty trucks, as well as fleet turnover replacing older equipment and vehicles in later years.

Construction is proposed to finish in late 2026 and the Project would undergo a standard process to obtain its certification of occupancy and would begin leasing. The operational year 2027 relates to future traffic operations and assumes a fully leased building for maximum trip and VMT purposes.

Estimates provided by the Applicant, July 2022.

The estimated operational year is 2027.³⁰

The Project will demolish 27,011 square feet of existing buildings and approximately 16,000 square feet of surface parking lot asphalt.

For a conservative assumption, the Project will excavate at a depth of approximately 6 feet for, foundation elements, and grading of soils.³¹

0 cubic yards of fill will be imported to the Site. The amount of materials exported will be up to approximately 10,000 cubic yards (accounting for swell/expansion amount).³²

The haul route would be approximately 30 miles one-way, or 60 miles roundtrip, and could include the following:

- Full trucks: Exit Site on Lexington Avenue and travel south on Vine Street to east on Santa Monica Boulevard to south on US-101 to I-10 East, to the CA-60 East, to the I-605 North to exit Live Oak Avenue to Arrow Highway, to Vincent Avenue, to Azusa Landfill (1211 Gladstone Street, Azusa, CA 91702).
- Empty trucks would travel in the reverse to the Site and exit US-101 on Santa Monica Boulevard.

³⁰ Transportation Assessment, Gibson Transportation Consulting, November 2, 2022.

³¹ Plans, KTG, June 2, 2022.

³² Estimates provided by the Applicant, July 2022. Assumes 8,439 cy with a soil swell percent of 18.5% = 10,000 cy.

Truck routes are expected to utilize the most convenient access to freeway ramps. The truck routes would comply with the approved truck routes designated within the City and/or adjacent jurisdictions. Trucks traveling to and from the Project Site must travel along the designated routes.

4.12 Discretionary Requests

Discretionary entitlements required to implement the Project will include, but are not necessarily limited to, the following:³³

- **Density Bonus (DB)**, pursuant to LAMC Section 12.22 A.25(g)(3), approval of a Density Bonus Application for a project having 153 residential dwelling units, including 18 units reserved for Very Low Income households (17% of the base units, or 11 percent of the total number of units), with the following Off-Menu Incentives:
 - **Off-Menu Incentive**, for an increase in the Floor Area Ratio (FAR) to 3.51:1 in lieu of the otherwise allowable maximum of 0.5:1 in the C2-1D Zone, as restricted by Ordinance Number 164,692;
 - **Off-Menu Incentive**, for a decrease in the required rear yard to allow 10 feet in lieu of 20 feet required in the C2-1D Zone; and
 - **Off-Menu Incentive**, for a decrease in the required side yard to allow 0 feet in lieu of 10 feet required in the C2-1D Zone.
- **Conditional Use permit (CU)**, pursuant to LAMC Section 12.24 U.26, for a Conditional Use permit to allow a 15 percent increase in density beyond the maximum 35 percent permitted in LAMC Section 12.22 A.25, for a total increase in density of 50% to provide a total of 153 residential dwelling units, setting aside 17% of its base density units for Very Low Income Households.

Site Plan Review (SPR) pursuant to LAMC Section 16.05, for a development project that results in an increase of 50 or more dwelling units and/or guest rooms.

Class 32 Categorical Exemption, pursuant to the State of California Environmental Quality Act and CEQA Guidelines, Section 15300.

Other discretionary and ministerial permits and approvals that may be deemed necessary, including, but not limited to, temporary street closure permits, grading permits, haul route approval and permits, excavation permits, foundation permits, building permits, and sign permits.

³³ [Findings and Supplemental Information, Attachment A](#), filed September 2022.

Section 2

Environmental Analysis

1 Regulatory Framework

Title 14 of the California Code of Regulations, Chapter 3 (Guidelines for Implementation of the California Environmental Quality Act (CEQA), Article 19 (Categorical Exemptions), Section 15300 (Categorical Exemptions) includes a list of classes of projects which have been determined not to have a significant effect on the environment and which shall, therefore, be exempt from the provisions of CEQA.

The Project is categorically exempt from CEQA under the Class 32 exemption, as set forth in Section 15332, Article 19, Chapter 3, Title 14 of the California Code of Regulations (CCR). The Class 32 exemption promotes infill development within urbanized areas by exempting qualifying urban in-fill projects that are consistent with the local general plan and zoning requirements and can be served with existing utilities and public services. The Class 32 exemption does not apply to projects that would result in significant traffic, noise, air quality, or water quality impacts. Application of this exemption, as with all categorical exemptions, is limited by the regulatory exceptions identified in Section 15300.2, listed below. Each area of qualification and/or exception is discussed in detail in this CE.

Section 15332. In-Fill Development Projects.

Class 32 consists of projects characterized as in-fill development meeting the conditions described in this section.

(a) The project is consistent with the applicable general plan designation and all applicable general plan policies as well as with applicable zoning designation and regulations.

(b) The proposed development occurs within city limits on a project site of no more than five acres substantially surrounded by urban uses.

(c) The project site has no value as habitat for endangered, rare or threatened species.

(d) Approval of the project would not result in any significant effects relating to traffic, noise, air quality, or water quality.

(e) The site can be adequately served by all required utilities and public services.

Section 15300.2. Exceptions

(a) Location. Classes 3, 4, 5, 6, and 11 are qualified by consideration of where the project is to be located - a project that is ordinarily insignificant in its impact on the environment may in a particularly sensitive environment be significant. Therefore, these classes are considered to apply [to] all instances, except where the project may impact on an environmental resource of hazardous or critical concern where designated, precisely mapped, and officially adopted pursuant to law by federal, state, or local agencies.

(b) Cumulative Impact. All exemptions for these classes are inapplicable when the cumulative impact of successive projects of the same type in the same place, over time is significant.

(c) Significant Effect. A categorical exemption shall not be used for an activity where there is a reasonable possibility that the activity will have a significant effect on the environment due to unusual circumstances.

(d) Scenic Highways. A categorical exemption shall not be used for a project which may result in damage to scenic resources, including but not limited to, trees, historic buildings, rock outcroppings, or similar resources, within a highway officially designated as a state scenic highway. This does not apply to improvements which are required as mitigation by an adopted negative declaration or certified EIR.

(e) Hazardous Waste Sites. A categorical exemption shall not be used for a project located on a site which is included on any list compiled pursuant to Section 65962.5 of the Government Code.

(f) Historical Resources. A categorical exemption shall not be used for a project which may cause a substantial adverse change in the significance of a historical resource.

2 Discussion of CCR Section 15332(a)

The project is consistent with the applicable general plan designation and all applicable general plan policies as well as with applicable zoning designation and regulations.

In order to qualify for a Class 32 exemption, a project must be found to be consistent with the applicable general plan designation and all applicable general plan policies as well as with applicable zoning designation and regulations.

2.1 General Plan

The General Plan consists of seven State-mandated elements: Land Use, Mobility, Noise, Safety, Housing, Open Space, and Conservation; and elements addressing Air Quality, Infrastructure Systems, Public Facilities and Services, Health and Wellness, as well as the Citywide General Plan Framework Element. The Framework Element establishes the overall policy and direction for the City's entire General Plan. It provides a citywide context and a comprehensive long-range strategy to guide the comprehensive update of the General Plan's other mandated and optional elements. The Framework Element establishes the fundamental and over-arching goals, objectives and policies for the City and its Community Plans and Specific Plans.

2.1.1 Land Use

In Los Angeles, the Land Use element of the General Plan is made up of the City's 35 Community Plans. The Project would demonstrate consistency with the Land Use Element through consistency with the Community Plan (discussed below).

2.1.2 Mobility Element

The goals of the Transportation Chapter of the Framework Element are to provide adequate accessibility to commerce, work opportunities, and essential services, and to maintain acceptable levels of mobility for all those who live, work, travel, or move goods in the City. The Transportation Chapter includes proposals for major transportation improvements to enhance the movement of goods and to provide greater access to major intermodal facilities, such as the ports and airports. As discussed in the Transportation Chapter of the Framework Element, the goals, objectives, policies, and related implementation programs of the Transportation Chapter are set forth in the Transportation Element of the General Plan adopted by the City in September 1999.

As an update to the Transportation Element, the City Council initially adopted Mobility Plan 2035 in August 2015. The Mobility Plan 2035 was readopted in January 2016 and amended in September 2016.¹ Mobility Plan 2035 incorporates "complete streets" principles and lays the policy foundation for how the City's residents interact with their streets. Mobility Plan 2035 includes five main goals that define the City's high-level mobility priorities: (1) Safety First; (2) World Class Infrastructure; (3) Access for All Angelenos; (4) Collaboration, Communication, and Informed Choices; and (5) Clean Environments and Healthy Communities. Each of the goals contains objectives and policies to support the achievement of those goals. Accordingly, the goals

¹ City of Los Angeles, Department of City Planning, Mobility Plan 2035, adopted September 2016.

of the Transportation Chapter of the Framework Element are now implemented through Mobility Plan 2035.

2.1.3 Noise Element

The Noise Element includes programs and noise mitigation guidelines, but also recognizes that many noise sources are beyond the City’s jurisdictional control. The Noise Element is implemented by the City’s noise ordinances, against which the Project’s noise impacts are analyzed herein.

2.1.4 Safety Element

Adopted in November 2021, the Safety Element offers a high-level overview of how the City plans for disasters. California Government Code specifies General Plan requirements that pertain to safety, which can be addressed in the Safety Element or the Local Hazard Mitigation Plan. The Local Hazard Mitigation Plan (LHMP) guides the City in reducing risks from disasters to people, property, economy and environment.²

The Safety Element of the General Plan provides a contextual framework for understanding the relationship between hazard mitigation, response to a natural disaster and initial recovery from a natural disaster. Chapters I and III of the Safety Element outline the scope of the City Emergency Operations Organization (EEO)’s on-going efforts to use experiences and new information to improve the City’s hazard program. Chapter II outlines the City’s historic commitment to improving its prevention of controllable disasters, mitigation of impacts associated with disasters and response to disaster events.

Goals and policies of the Safety Element, relate to hazard mitigation by the City, including emergency response (multi-hazard), and disaster recovery (multi-hazard). The goals and objectives of the Safety Element provide a guideline for the City’s service systems and do not relate to actions of the private developer. As such, these goals and objectives are not evaluated. However, regulations arising out of the objectives of the Safety Element are reflected in the Building and Safety Code and the Fire Code provision with which the Project must comply in order to obtain building permits and a certificate of occupancy.

2.1.5 Housing Element

Adopted in November 2021, the Housing Element 2021–2029 of the City’s General Plan identifies five primary goals that will guide the Element:³

- Goal 1: A City where housing production results in an ample supply of housing to create more equitable and affordable portions that meet existing and projected needs.
- Goal 2: A City that preserves and enhances the quality of housing and provides greater housing stability for households of all income levels.

² City of Los Angeles, Department of City Planning, Safety Element, adopted November 2021.

³ Los Angeles, Housing Element 2021-2029, adopted November 2021: <https://planning.lacity.org/plans-policies/housing-element-update#adopted-plan>

- Goals 3: A City in which housing creates healthy, livable, sustainable, and resilient communities that improve the lives of all Angelenos.
- Goal 4: A City that fosters racially and socially inclusive neighborhoods and corrects the harms of historic racial, ethnic, and social discrimination of the past and present.
- Goal 5: A City that is committed to preventing and ending homelessness.

The Regional Housing Needs Assessment (RHNA) is the State required process that seeks to ensure cities and counties are planning for enough housing to accommodate all economic segments of the community. For this current 2021-2029 Housing Element 6th cycle, the regional Southern California Association of Governments (SCAG) issued a target of 456,643 housing units for the entire City of Los Angeles, of which 184,721 units (40%) are designated for very low-and low-income households.

On February 22, 2022, the California Department of Housing and Community Development (HCD) rejected the 2021 Housing Element⁴, telling the City that it must re-zone more quickly to comply with stricter state laws that are aimed at more development across California. Under the state's ruling, the city must rezone for 255,000 new homes by mid-October, instead of over the next three years.

Los Angeles City Planning and the Los Angeles Housing Department worked together to address feedback received from HCD and prepare revisions (targeted amendments) to programs to address the new Affirmatively Furthering Fair Housing (AFFH) requirements. On June 14, 2022, the Los Angeles City Council adopted the targeted amendments to the 2021-2029 Housing Element (Council File No. 21-1230-S1).

The amended Housing Element was provided to HCD immediately after its adoption for review and certification.⁵ On June 29, 2022, HCD confirmed that the amended Housing Element is in full compliance with State Housing Element Law.⁶

2.1.6 Open Space Element

The Open Space and Conservation Chapter of the Framework Element contains goals, objectives, and policies to guide the provision, management, and conservation of public open space resources; address the outdoor recreational needs of the City's residents; and guide amendments to the General Plan Open Space Element and Conservation Element.

2.1.7 Conservation Element

The City of Los Angeles General Plan includes a Conservation Element. Section 5 of the Conservation Element recognizes the City's responsibility for identifying and protecting its cultural and historical heritage. The Conservation Element established an objective to protect important

⁴ California Department of Housing and Community Development, https://planning.lacity.org/odocument/f058cf1b-ce3a-4e10-ad07-9972e24585e2/HCD_comment_Letter.pdf

⁵ Los Angeles, Housing Element 2021-2029, news: <https://planning.lacity.org/plans-policies/community-plan-update/housing-element-news/city-council-adopts-targeted-amendments>

⁶ California Department of Housing and Community Development: <https://planning.lacity.org/odocument/c30f832f-9f91-47ff-bcc0-69f33b197a11/LACityAdoptedIN062922.pdf>

cultural and historical sites and resources for historical, cultural, research, and community educational purposes and a corresponding policy to continue to protect historic and cultural sites and/or resources potentially affected by proposed land development, demolition, or property modification activities.⁷

2.1.8 Consistency Analysis

Table 2-1, General Plan, lists the goals for land use that apply to developers in collaboration with local government. As shown, the Project will be consistent with the applicable (developer-controlled or focused) goals of the General Plan for each land use. The Project’s residential and commercial uses are consistent with the goals of the General Plan Framework. Therefore, there would be no significant impacts due to consistency with land use designations in the General Plan.

The Framework Element is a strategy for long-term growth which sets a citywide context to guide the update of the Community Plan and Citywide Elements. The Framework Element is a comprehensive, long range document containing purposes, policies and programs for the development of the City of Los Angeles. The Citywide General Plan Framework text defines policies related to growth and includes policies for land use, housing, urban form/neighborhood design, open space/conservation, economic development, transportation, and infrastructure/public services.

**Table 2-1
General Plan Framework, Mobility, Housing, Conservation, Health and Wellness, and
Infrastructure and Public Services and Element Consistency Analysis**

Goal, Objectives, Policies	Discussion
Framework Element Land Use Chapter	
Multi-Family Residential	
GOAL 3C. Multifamily neighborhoods that enhance the quality of life for the City's existing and future residents.	Consistent. The Project Site is in an urbanized area with street frontage on Vine Street (designated a Avenue II in the 2035 Mobility Plan), with full infrastructure to accommodate the proposed use.
Objective 3.4. Encourage new multi-family residential, retail commercial, and office development in the City's neighborhood districts, community, regional, and downtown centers as well as along primary transit corridors/boulevards, while at the same time conserving existing neighborhoods and related districts.	Consistent. The Project with 153 dwelling units, including 18 units set aside for Very Low Income households, conforms to permitted density with the requested Density Bonus. The Project will expand the existing multifamily neighborhood and enhance the quality of life for the City's existing and future residents by providing a range of residential units, including units set aside for Very Low Income households, within a modern and quality designed development which will include on-site amenities to serve the Project residents as well as ground-floor commercial uses which will serve the neighborhood.

⁷ City of Los Angeles Conservation Element of the General Plan, adopted September 26, 2001, p. II-9.

<p>Objective 3.7. Provide for the stability and enhancement of multi-family residential neighborhoods and allow for growth in areas where there is sufficient public infrastructure and services and the residents' quality of life can be maintained or improved.</p> <p>Policies. 3.7.1 Accommodate the development of multi-family residential units in areas designated in the community plans in accordance with Table 3-1 and Zoning Ordinance densities indicated in Table 3-3, with the density permitted for each parcel to be identified in the community plans.⁸</p>	<p>Consistent. The Project Site is located within close proximity of public transit. The Project Site has a General Plan land use designation of Highway Oriented Commercial, which corresponds with the C2-zoning of the Project Site (among other zones) which is equivalent to the High Medium land use designation indicated in Tables 3-1 and 3-3. Table 3-1 and Table 3-3 note that the “High Medium” Multi-Family Residential Land Use Designation corresponds to the R4 Zone. The Project Site is in the C2 Zone, which permits multi-family residential at the High Medium (R4) density (a density of 56-109 dwelling units per net acre, per Table 3-3).</p>
<p>Housing</p> <p>GOAL 4A. An equitable distribution of housing opportunities by type and cost accessible to all residents of the City.</p>	<p>Consistent. The Project will provide 153 apartment units, including 18 units set aside for Very Low Income households. This will supplement the existing housing stock in the Hollywood Community Plan area with diversity and contribute to the affordable housing supply. The Property is located within an established mixed-use center in Los Angeles and is designated for Highway Serving Commercial uses by the existing Hollywood Community Plan. As Los Angeles moves towards greater transit network connectivity, the Property is well suited not only for its original land use designated related to highway serving uses, but to serve the broader Hollywood community with numerous connections to other areas throughout Los Angeles from both bus and rail transit options.</p>
<p>Housing</p>	
<p>Objective 4.1. Plan the capacity for and develop incentives to encourage production of an adequate supply of housing units of various types within each City sub region to meet the projected housing needs by income level of the future population to the year 2010.</p>	<p>Consistent. The Project will provide 153 apartment units, including 18 units set aside for Very Low Income households. This will supplement the existing housing stock in the Hollywood Community Plan area with diversity and contribute to the affordable housing supply.</p>
<p>Objective 4.2. Encourage the location of new multi-family housing development to occur in proximity to transit stations, along some transit corridors, and within some high activity areas with adequate transitions and buffers between higher-density developments and surrounding lower-density residential neighborhoods.</p>	<p>Consistent. The Project is located 0.4 miles from the Metro B Line stop at Sunset and Vine, with connections to the entire Metro Rail system at 7th Street Metro Center and Union Station. In addition, the Project also has a stop for the Metro Bus Route 210 immediately in front of the Site, as well as to the LADOT Hollywood Clockwise and Hollywood/Wilshire routes within two-blocks of the Site. In addition, 0.4 miles to the north at Sunset Boulevard and Vine Street the Property is connected to Metro Bus Routes 2 and 4. All of these transit routes connect the Property to east and west Los Angeles, the San</p>

⁸ Table 3-1 and Table 3-3 note that the “High Medium” Multi-Family Residential Land Use Designation corresponds to the R4 Zone. The Project Site is in the C2 Zone, which permits multi-family residential at the High Medium (R4) density (a density of 56-109 dwelling units per net acre, per Table 3-3).

	<p>Fernando Valley, and south Los Angeles and southern cities.</p> <p>Furthermore, the Project Site is in close proximity to the Hollywood Pool and Recreation Center, Vine Street Early Education Center, and De Longpre Park. Therefore, the Project is consistent with the General Plan as it supports the addition of residential units near commercial districts with transit options.</p> <p>The Project will create a new desirable place in which the community can live, work and visit, which is also well-served by various public transit options.</p>
Objective 4.3. Conserve scale and character of residential neighborhoods.	Consistent. The building is appropriately scaled and designed to integrate into the mixed-use neighborhood of Hollywood.
Mobility Element	
Policy 2.3. Recognize walking as a component of every trip, and ensure high quality pedestrian access in all site planning and public right-of-way modifications to provide a safe and comfortable walking environment.	Consistent. The Project would be located within a commercial corridor that is characterized by a high degree of pedestrian activity. The Project would further promote pedestrian activity by developing a mixed use residential and commercial use in proximity to public transit options, with streetscape improvements such as street trees and landscaping.
Policy 3.1. Recognize all modes of travel, including pedestrian, bicycle, transit, and vehicular modes - including goods movement – as integral components of the City’s transportation system.	<p>Consistent. The Project would promote this policy by providing adequate vehicular access, improving pedestrian access, and providing bicycle facilities.</p> <p>The Project includes 14 short-term and 106 long-term bicycle parking spaces, per LAMC requirements.</p>
Policy 3.2. Accommodate the needs of people with disabilities when modifying or installing infrastructure in the public right-of-way.	Consistent. The Project would be designed to provide accessibility and accommodate the needs of people with disabilities as required by the American with Disabilities Act (ADA) and the City’s applicable related building code regulations.
Policy 3.3. Promote equitable land use decisions that result in fewer vehicle trips by providing greater proximity and access to jobs, destinations, and other neighborhood services.	Consistent. The Project would promote equitable land use decisions that result in fewer vehicle trips by providing a new mixed-use residential and commercial development in close proximity to public transit options, and jobs.
Policy 3.4. Provide all residents, workers and visitors with affordable, efficient, convenient, and attractive transit services.	Consistent. The Project would be located in an area well-served by public transit provided by Metro, including bus lines 210 and 4 and LADOT DASH Hollywood. The Metro rail B line is 2,950 feet north of the Site.
Policy 3.5. Support “first-mile, last-mile solutions” such as multi-modal transportation services, organizations, and activities in the areas around transit stations and major bus stops (transit stops) to maximize multi-modal connectivity and access for transit riders.	Consistent. The Project would activate the area around major transit stops with housing and commercial use.

<p>Policy 3.7. Improve transit access and service to major regional destinations, job centers, and inter-modal facilities.</p>	<p>Consistent. The Project would be located in an area well-served by public transit provided by Metro, including bus lines 210 and 4 and LADOT DASH Hollywood. The Metro rail B line is 2,950 feet north of the Site.</p>
<p>Policy 3.8. Provide bicyclists with convenient, secure and well maintained bicycle parking facilities.</p>	<p>Consistent. The Project provides bicycle parking spaces in accordance with LAMC requirements. The Project includes 14 short-term and 106 long-term bicycle parking spaces, per LAMC requirements.</p>
<p>Policy 3.9. Discourage the vacation of public rights-of-way</p>	<p>Consistent. The Project would not vacate any public rights-of-way, all associated public rights-of-way would be maintained as part of the Project.</p> <p>A Los Angeles Bureau of Engineering (BOE) Planning Case Referral Form (PCRF) was requested on June 12, 2022 to determine any potential highway dedications on the public streets adjoining the Site. No dedication on Vine Street or Lexington Avenue has been requested by BOE.</p>
<p>Policy 3.10. Discourage the use of cul-de-sacs that do not provide access for active transportation options.</p>	<p>Consistent. The Project would not include the development of a cul-de-sac. Vine Street and Lexington Avenue are through streets.</p>
<p>Policy 4.8. Encourage greater utilization of Transportation Demand Management (TDM) strategies to reduce dependence on single-occupancy vehicles.</p>	<p>Consistent. If the Project is estimated to generate a net increase of 250 or more daily vehicle trips and requires discretionary action, a transportation assessment for a Project is required.⁹</p> <p>LADOT's VMT calculator, Version 1.3, was used to determine if the project would exceed any of the Transportation Impact Assessment criteria which would require further transportation impact analysis.</p> <p>The Project would generate 1,025 daily vehicle trips, which exceeds LADOT's transportation assessment guidelines screening criteria and a vehicle miles traveled analysis (VMT) is required.</p> <p>For the purposes of this analysis, the VMT evaluation accounted for a reduced parking supply from baseline LAMC requirements and the inclusion of short-term and long-term bicycle parking per LAMC requirements.</p> <p>The VMT Calculator estimates that the Project would generate 1,320 total household VMT. Thus, based on the population assumptions, the Project would generate an average household VMT per capita of 3.7, which would not exceed the significance thresholds for the Central APC (6.0 household VMT</p>

⁹ LADOT, [Transportation Assessment Guidelines](#), August 2022.

	<p>per capita). Therefore, the Project would not result in a significant household VMT impact.¹⁰</p>
<p>Policy 4.13. Balance on-street and off-street parking supply with other transportation and land use objectives.</p>	<p>Consistent. The Mobility Plan 2035 recognizes that an oversupply of parking can undermine broader regional goals of creating vibrant public spaces and a robust multimodal mobility system and that parking consumes a vast amount of space in the urban environment, which otherwise could be put to valuable alternative uses. Additionally, the Mobility Plan observes that large parking lots create significant environmental impacts, detract from neighborhoods’ visual quality, and discourage walking by increasing the distances between services and facilities. Adequate parking would be provided on-site in accordance with LAMC requirements, including bicycle facilities. Furthermore, the Project would be located in an area well-served by public transit, which would reduce parking demand.</p>
<p>Policy 5.2. Support ways to reduce vehicle miles traveled (VMT) per capita.</p>	<p>Consistent. The Project would include mixed-use residential and commercial uses located in a commercial corridor characterized by a high degree of pedestrian activity. The Project would provide greater proximity to neighborhood services, jobs, and residences and would be well-served by existing public transportation. Therefore, the Project would support VMT reductions.</p> <p>LADOT concluded that the Project would not result in a significant VMT impact.¹¹</p>
<p>Policy 5.4. Continue to encourage the adoption of low and zero emission fuel sources, new mobility technologies, and supporting infrastructure.</p>	<p>Consistent. While this policy applies to large-scale goals relative to fuel sources, technologies and infrastructure, the Project would facilitate the use of alternative-fuel, low-emitting, and fuel-efficient vehicles by providing parking spaces that are capable of supporting future installation of electric vehicle supply equipment (EVSE), per the applicable LAMC Section 99.04.106.8.</p> <p>The Project would provide 29 EVSE spaces, of which 10 would have EVCS.</p>
<p>Policy 5.5. Maximize opportunities to capture and infiltrate stormwater within the City’s public right-of-ways.</p>	<p>Consistent. During construction, the Project would incorporate a Stormwater Pollution Prevention Plan (SWPPP) that includes the implementation of best management practices (BMPs) and other erosion control measures to minimize the discharge of pollutants in stormwater runoff in accordance with the state’s General Industrial Stormwater Permit. In addition, during operation, the Project would include</p>

¹⁰ [Transportation Assessment](#), Gibson Transportation Consulting, November 2, 2022.

¹¹ [Approval Letter](#), Los Angeles Department of Transportation, December 19, 2022.

	BMPs to collect, detain, treat, and discharge runoff on-site before discharging into the municipal storm drain system as part of the City’s Low Impact Development (LID) ordinance.
Housing Element (2021-2029)	
Objective 1.1. Forecast and plan for existing and projected housing needs over time with the intention of furthering Citywide Housing Priorities.	Consistent. The Project would develop a variety of floor plan layouts and bedroom types, including 153 new multi-family residential units with 18 affordable VLI units. The 153 units include 21 studio units, 89 1-bedroom units, and 43 2-bedroom units. The Project would contribute to the total number of dwelling units as deemed necessary in the Regional Housing Needs Assessment.
Objective 1.2. Facilitate the production of housing, especially projects that include Affordable Housing and/or meet Citywide Housing Priorities.	Consistent. The Project would not involve the removal of any existing housing and would add 153 new multi-family residential units including 18 units set aside for Very Low Income households .
Objective 3.1. Use design to create a sense of place, promote health, foster community belonging, and promote racially and socially inclusive neighborhoods.	Consistent. The mixed-use Project has been developed to provide an appropriate and high-quality design that is compatible with existing development in the community. As such, the Project would promote a livable neighborhood with a mix of housing types in a well-designed building.
Objective 3.2. Promote environmentally sustainable buildings and land use patterns that support a mix of uses, housing for various income levels and provide access to jobs, amenities, services and transportation options.	Consistent. The Project would comply with the Los Angeles Green Building Code (LAGBC). Further, pursuant to the California’s CALGreen Building Standards, the Project Applicant would be required to recycle/divert construction waste generated on the Project Site in accordance with the LAMC. The EV parking requirement reduces dependency on fossil fuels. The Project would provide 29 EVSE spaces, of which 10 would have EVCS. As such, the Project would contribute to the promotion of development of sustainable buildings to minimize the adverse effects on the environment and the use of non-renewable resources. The Project Site is an infill site located within walking distance to transit options. As such, the Project would contribute to the promotion of a sustainable community.
Objective 4.1. Ensure that housing opportunities are accessible to all residents without discrimination on the basis of race, color, ancestry, sex, national origin, color, religion, sexual orientation, gender identity, marital status, immigration status, family status, age, intellectual, developmental, and physical disability, source of	Consistent. The Project would comply with all federal, state, and local laws regarding equal housing without discrimination on the basis of race, ancestry, sex, national origin, color, religion, sexual orientation, marital status, familial status, age, disability (including HIV/AIDS), and student status.

<p>income and student status or other arbitrary reason.</p>	
<p>Conservation Element</p>	
<p>15.1 Objective: Protect and reinforce natural and scenic vistas as irreplaceable resources and for the aesthetic enjoyment of present and future generations.</p>	<p>Consistent. The Project Site and surrounding area are characterized by dense urban development. Due to existing buildings in the area, views are generally obstructed, and no scenic vistas exist. Therefore, the Project would not have any adverse effect on a scenic vista for the enjoyment of present and future generations.</p>
<p>15.1 Policy: Continue to encourage and/or require property owners to develop their properties in a manner that will, to the greatest extent practical, retain significant existing land forms (e.g., ridge lines, bluffs, unique geologic features) and unique scenic features (historic, ocean, mountains, unique natural features) and/or make possible public view or other access to unique features or scenic views.</p>	<p>Consistent. The Project Site does not contain any significant existing land forms (e.g., ridge lines, bluffs, unique geologic features) or unique scenic features (historic, ocean, mountains, unique natural features). The Project Site is located in an urbanized portion of the City and topographically relatively flat. The Project Site is not a part of a scenic resource and would not obstruct any scenic views.</p>
<p>Health and Wellness Element</p>	
<p>1.5 Improve Angelenos’ health and well-being by incorporating a health perspective into land use, design, policy, and zoning decisions through existing tools, practices, and programs.</p>	<p>Consistent. The Project would provide housing opportunities to the community within walking distance to existing bus lines, helping to reduce dependence on vehicles and the air pollutants generated by vehicular traffic. In addition, the Project would be located within and near the job centers of Los Angeles.</p>
<p>2.2 Promote a healthy built environment by encouraging the design and rehabilitation of buildings and sites for healthy living and working conditions, including promoting enhanced pedestrian-oriented circulation, lighting, attractive and open stairs, healthy building materials and universal accessibility using existing tools, practices, and programs.</p>	<p>Consistent. The Project would promote pedestrian activity, with a residential and commercial development.</p> <p>The Project would be designed to encourage pedestrian activity. Use of bicycles to and from the Project Site would be encouraged as part of the Project by the provision of ample and safe bicycle parking. The number, type of spaces, and dimensions would be provided based on LAMC Sections 12.21-A,16 and 12.21-A,4(c). The bicycle spaces would be provided in a readily accessible location(s). Appropriate lighting would be provided to increase safety and provide theft protection during nighttime parking.</p>
<p>2.3 Strive to eliminate barriers for individuals with permanent and temporary disabilities to access health care and health resources.</p>	<p>Consistent. Design of the Project would comply with all existing federal, state, and local regulations, including the Americans with Disabilities Act (ADA) and the state and City building codes to eliminate barriers for individuals with permanent and temporary disabilities.</p>
<p>2.11 Lay the foundation for healthy communities and healthy living by promoting infrastructure improvements that support active transportation with safe, attractive, and comfortable facilities that</p>	<p>Consistent. See Policy 1.5 above regarding how the Project’s mix of uses and location near transit would support healthy communities and healthy living.</p>

meet community needs; prioritize implementation in communities with the greatest infrastructure deficiencies that threaten the health, safety, and well-being of the most vulnerable users.	
3.8 Support public, private, and nonprofit partners in the ongoing development of new and innovative active spaces and strategies to increase the number of Angelenos who engage in physical activity across ages and level of abilities.	Consistent. The Project meets the LAMC requirement. This includes an outdoor decks, indoor amenities, and balconies.
5.1 Reduce air pollution from stationary and mobile sources; protect human health and welfare and promote improved respiratory health.	Consistent. The Project would facilitate the use of alternative-fuel, low-emitting, and fuel-efficient vehicles by providing parking spaces that are capable of supporting future installation of electric vehicle supply equipment (EVSE), per the applicable LAMC Section 99.04.106.8. See Policy 1.5 above regarding how the Project's uses and location near transit would support healthy communities and healthy living.
5.3 Reduce exposure to second-hand smoke by promoting smoke-free environments and market and support public, private, and nonprofit cessation programs and services.	Consistent. The Project would reduce exposure to second-hand smoke in accordance with applicable law, such as prohibition on smoking in rental residential units (California Civil Code Section 1947.5).
5.4 Protect communities' health and well-being from exposure to noxious activities (for example, oil and gas extraction) that emit odors, noise, toxic, hazardous, or contaminant substances, materials, vapors, and others.	Consistent. The Project's regional and local, construction emissions and operational emissions would be less than significant (see the air quality analysis below). The Project would comply with existing regulations pertaining to hazardous materials to ensure that no significant impacts related to upset and accident conditions related to hazardous materials would occur as a result of the Project. Finally, the Project does not include facilities that would use hazardous materials, such as a dry cleaner, industrial manufacturing processes, or automotive repair facilities. The Project would not result in any impacts related to odors.
5.7 Promote land use policies that reduce per capita greenhouse gas emissions, result in improved air quality and decreased air pollution, especially for children, seniors and others susceptible to respiratory diseases.	Consistent. The Project would comply with Section 2485 in CCR Title 13, which requires trucks and vehicles in loading and unloading queues to have their engines turned off after five minutes when not in use, in order to reduce vehicle emissions.
Infrastructure and Public Services Chapter	
Policy 9.3.1: Reduce the amount of hazardous substances and the total amount of flow entering the wastewater system.	Consistent. The Project would support this City policy through compliance with City grading permit regulations (Chapter IX, Division 70 of the LAMC), which requires the preparation of an erosion control plan, to reduce the effects of sedimentation and erosion. The Project would also be required to comply with the City's LID Ordinance (Ordinance No. 181,899), which promotes the use of natural infiltration systems, evapotranspiration, and the reuse of

	<p>stormwater. Thus, Best Management Practices (BMPs) would be implemented to collect, detain, treat, and discharge runoff on-site before discharging into the municipal storm drain system.</p> <p>The treatment method proposed for the Project Site is the implementation of High Efficiency Biofiltration Systems (flow-through planters) to manage stormwater runoff in accordance with current LID requirements. Thus, the Project would reduce the amount of hazardous substances and total amount of flow entering the wastewater system.</p>
<p>Objective 9.6: Pursue effective and efficient approaches to reducing stormwater runoff and protecting water quality.</p>	<p>Consistent. See Policy 9.3.1. above under Infrastructure and Public Services Chapter.</p>
<p>Objective 9.10: Ensure that water supply, storage, and delivery systems are adequate to support planned development.</p>	<p>Consistent. Based on LADWP’s demand projections provided in its 2020 Urban Water Management Plan (UWMP)¹², LADWP would be able to meet the water demand of the Project, as well as the existing and planned future water demands of its service area. As the Project’s water demand is accounted for in the City’s future projected demands (the 2020-2045 RTP includes growth throughout the Los Angeles subregion and informs the LADWP 2020 UWMP), the Project would not require the construction or expansion of new water treatment facilities that could cause a significant environmental effect.</p> <p>In general, projects that conform to SCAG’s 2020-2045 RTP demographic projections and are in the City’s service area are considered to have been included in LADWP’s water supply planning efforts in the UWMP. In terms of the City’s overall water supply condition, the water requirement for any project that is consistent with the City’s General Plan has been taken into account in the planned growth of the water system. Furthermore, the Project would not exceed the available capacity within the distribution infrastructure that would serve the Project Site.</p>
<p>Goal 9P: Appropriate lighting required to: (1) provide for nighttime vision, visibility, and safety needs on streets, sidewalks, parking lots, transportation, recreation, security, ornamental, and other outdoor locations; (2) provide appropriate and desirable regulation of architectural and information lighting such as building façade lighting or advertising lighting; and</p>	<p>Consistent. The Project would introduce new sources of artificial light to the Project Site, including low-level exterior lights for security and way-finding purposes, as well as general accent lighting.</p> <p>The Project would not include electronic lighting or signs with flashing or strobe lights. All exterior lighting would be shielded or directed toward the areas to be</p>

¹² LADWP 2020 Urban Water Management Plan, page ES-6: https://www.ladwp.com/ladwp/faces/ladwp/aboutus/a-water/a-w-sourcesofsupply/a-w-sos-uwmpLn.jsessionid=0LnWhxdVj2Jjg2Vm6Xrr4rmqyLL9GtlpLdJBQxVQgdb53TnwhJRB!-1106340359?_afLoop=151440072116797&_afWindowMode=0&_afWindowId=null#%40%3F_afWindowId%3Dnull%26_afLoop%3D151440072116797%26_afWindowMode%3D0%26_adf.ctrl-state%3Dw319yjmek_4

(3) protect and preserve the nighttime environment, views, driver visibility, and otherwise minimize or prevent light pollution, light trespass, and glare.	lit to limit spill-over onto off-site uses. The Project would comply with the City's lighting and signage ordinances and would have signage approved by LADBS.
<p>General Plan, Chapter 3-Land Use: https://planning.lacity.org/cwd/framwk/chapters/03/03207.htm City of Los Angeles, Conservation Element of the General Plan, March 2001. Housing Element: http://planning.lacity.org/HousingInitiatives/HousingElement/Text/Ch6.pdf City of Los Angeles, Health and Wellness Element of the General Plan, March 2015. General Plan, http://cityplanning.lacity.org/cwd/framwk/fwhome0.htm Note: This table includes only the policies that are applicable to the Project.</p>	

2.2 Hollywood Community Plan

The Community Plan is one of 35 community plans geographically established for different areas of the City to implement the policies of the General Plan Framework Element and comprise the Land Use Element. The specific purpose of the Community Plan is to promote an arrangement of land use, circulation, and services that encourages and contributes to the economic, social and physical health, safety, welfare, and convenience of the community within the larger framework of the City. In addition, the Community Plan serves to guide the development of the community to meet existing and anticipated needs and conditions, as well as to balance growth and stability, enable economic stability and growth, responsibly manage land development and other trends, and to protect investment.

The Project Site is located within the Hollywood Community Plan (adopted on December 13, 1988)¹³, which designates the Site as Highway Oriented Commercial land use. The Project Site is zoned C2-1D.

The Project Site is in the Hollywood Community Plan, which designates the site as Highway Oriented Commercial. The Hollywood Community Plan is undergoing a Community Plan Update (Update) and is currently in the adoption phase. The Update has been approved by the City Planning Commission which referred the Update to the City Council for adoption on August 19, 2021. The upcoming steps to complete adoption of the Update are receiving the recommendations for approval from the Los Angeles City Council's Planning and Land Use Management (PLUM) Committee, and then the final approval from the full City Council.¹⁴ Adoption is anticipated in 2023.

The Community Plan is the Land Use Element of the City's General Plan. The Community Plan also contains policies and objectives to guide development and uses planned within the City. As addressed above, not every goal, policy, or objective is of the Community Plan applicable to the Project or the Project Site, a demonstration of consistency with the General Plan requires a finding of general harmony with the plan. The Community Plan is intended to promote an arrangement of land use, circulation, and services that will encourage and contribute to the economic, social and physical health, safety, welfare, and convenience of the community within the larger framework of the City; guide the development of the Community Plan area to meet existing and

¹³ <https://planning.lacity.org/plans-policies/community-plan-area/hollywood>

¹⁴ Hollywood Community Plan Update: <https://planning.lacity.org/plans-policies/community-plan-update/hollywood-community-plan-update#about>

anticipated needs and conditions; to balance growth and stability; regulate land development and other trends; and protect investment.

Table 2-2, Community Plan, sets forth the Community Plan objectives for residential and commercial land use and discusses the Project’s consistency and applicability with each objective. The Project would not conflict with any of the objectives of the Community Plan.

The Hollywood Community Plan does not outline goals and policies as is traditionally the case for community plans throughout the City but instead includes a list of Objectives.

**Table 2-2
Hollywood Community Plan Consistency Analysis**

Objectives	Discussion
Objective 1: To further the development of Hollywood as a major center of population, employment, retail services, and entertainment; and to perpetuate its image as the international center of the motion picture industry.	Consistent. The Project proposes a mixed use development of 153 dwelling units and 7,000 square feet of commercial space, including 18 units set-aside for Very Low Income households. As such, the Project is providing needed multi-family residential development, appropriate housing along a mixed-use boulevard, increasing the choice of housing type for the area, and offering commercial/retail opportunities.
Objective 2: To make provision for the housing required to satisfy the varying needs and desires of all economic segments of the Community, maximizing the opportunity for individual choice.	Consistent. The Project’s Very Low Income units will increase access to housing in the community for lower income people and families. The Project contains a range of units from studio to two-bedroom units, as well as 18 units for Very Low Income households, which will ensure a mixed-income project to meet varying needs and maximize housing choices. The Project will help to alleviate the ongoing housing crisis in Los Angeles and will address the critical demand for affordable housing in the City without displacing existing residential tenants.
Objective 4.a: Allocating and distributing commercial lands for retail, service, and office facilities in quantities and patterns based on accepted planning principles and standards.	Consistent. The Project will locate high-quality commercial and residential uses in proximity to transit, and enhance the built environment with redevelopment of underutilized commercial space into a mixed use vibrant community.
https://planning.lacity.org/plans-policies/community-plan-area/hollywood	

2.3 Zoning Regulations

2.3.1 Local Emergency Temporary Regulations – Time Limits and Parking Relief

On July 1, 2021, pursuant to Ordinance 187,096, supplemental Local Emergency Temporary Regulations became effective (LAMC Section 16.02.1). Concurrently, as required by the

Ordinance, a Resolution was adopted by the City Council to activate these supplemental Temporary Regulations for a period of one year from the end of the Local Emergency declaration issued on March 4, 2020. Currently, the Local Emergency declaration is still valid and ongoing, and no end date for it or the Temporary Regulations established under this Ordinance has been determined. The extension of time limits applies to most CUPs and quasi-judicial actions. This does not apply to the Project.

The automobile parking requirements applies to change of use, outdoor dining, valet parking, and offsite parking. This does not apply to the Project.

2.3.2 State Enterprise Zone: Los Angeles

The Site is within an Enterprise Zone/Employment and Economic Incentive Program Area (EZ). The Federal, State and City governments provide economic incentives to stimulate local investment and employment through tax and regulation relief and improvement of public services. EZ special provisions applicable to plan check include parking standards and height. The Los Angeles State Enterprise Zone provides reduced parking requirements of 2 spaces for every 1,000 square feet of business, retail, restaurant, bar and related uses (LAMC Section 12.21.A.4(x)(3)6.).

The Project's commercial uses will utilize the Enterprise Zone's reduced parking requirement of 2 spaces for every 1,000 square feet.

2.3.3 Transit Priority Area in the City of Los Angeles

On September 2013, the Governor signed into law Senate Bill (SB) 743, which instituted changes to the California Environmental Quality Act (CEQA) when evaluating environmental impacts to projects located in areas served by transit. While the thrust of SB 743 addressed a major overhaul on how transportation impacts are evaluated under CEQA, it also limited the extent to which aesthetics and parking are defined as impacts under CEQA. Specifically, Section 21099 (d)(1) of the Public Resources Code (PRC) states that a project's aesthetic and parking impacts shall not be considered a significant impact on the environment if:

1. The project is a residential, mixed-use residential, or employment center project, and
2. The project is located on an infill site within a transit priority area.¹⁵

The Project contains multiple uses, including residential and commercial. The Project Site is an infill site, which is defined in pertinent part as a lot located within an urban area that has been previously developed.¹⁶ The Project Site is within a transit priority area, which is defined in pertinent part as an area within one-half mile of an existing major transit stop.¹⁷

¹⁵ <http://zimas.lacity.org/documents/zoneinfo/ZI2452.pdf>.

¹⁶ California Public Resources Code Section 21099(a)(4).

¹⁷ California Public Resources Code Section 21099(a)(7).

As a TPA, projects are entitled to certain exemptions under CEQA, as well as parking reductions of 0.5 spaces per unit for the provision of on-site affordable housing, as recently amended by State Assembly Bill AB 2345.

2.4 Zoning Code

The Project Site is zoned C2-1D, and is designated for Highway Oriented Commercial land uses by the Hollywood Community Plan. Height District 1 in commercial zones has no limit on height or stories¹⁸, with a maximum base Floor Area Ratio (FAR) of 1.5:1.

However, the D limitation on the Project Site allows up to 3:1 FAR but restricts the FAR of the commercial portion to 0.5:1.

The C2-2D zone permits both commercial and residential uses. The corresponding zones for the Highway Oriented Commercial land use designation include C1, C2, P, RAS3, and RAS4.¹⁹

Residential uses are permitted at one dwelling unit per 400 square feet of lot area.

The Project proposes to use Off-Menu Density Bonus incentives. The Project is eligible for the requested Off-Menu Incentives by dedicating 17% of the base density for Very Low-Income households, resulting in the provision of 18 of its total 153 units reserved for affordable households. The City has previously determined that potential incentives may be requested by an applicant in order to provide for affordable housing costs as defined in California Health and Safety Code Section 50052.5 or Section 50053.

In order to achieve cost reductions that allow for the provision of the 18 deed restricted affordable very low income units, the Applicant is requesting a Density Bonus approval with three (3) Off-Menu Incentives for:

- 1) FAR increase for a maximum of 3.51:1 in lieu of 3.0:1 and 0.5:1;
- 2) a reduction in the rear yard to provide 10 feet in lieu of the 20 feet otherwise required; and
- 3) a reduction in the side yard to provide 0 feet in lieu of the 10 feet otherwise required.

These incentives are necessary in order to incorporate the highest-quality new housing in this neighborhood and to provide 18 residential units (17% of the base density) dedicated to Very Low Income households.

The increase in FAR resulting in 3.51:1 is more appropriate for such a prominent location in Hollywood. The restriction to 0.5:1 is due to the “D” Condition, which is typical of commercial boulevards in Los Angeles, but is now outdated. A 3.51:1 FAR is suitable for a site of this size in such a prominent activity center, and to provide the substantial affordable housing component in this Project, with 18 affordable units. Granting the subject request for the increase in FAR will allow for the provision of additional market rate units that will offset the cost of the inclusion of

¹⁸ Commercial only uses limited to 45 feet pursuant to Commercial Corner development standards, mixed-use project are exempt and unlimited by height and stories.

¹⁹ General Plan Land Use Map: <https://planning.lacity.org/plans-policies/community-plan-area/hollywood>

restricted affordable units. Additionally, the increase in allowable Floor Area would allow for the construction of units in varying sizes and inclusion of multi-bedroom units to accommodate larger households, thus more marketable to a wider population. Without this requested increase, the FAR restriction would limit the Project to a 0.5:1 FAR, and prohibit the Applicant from providing a mixed-income housing project with such a substantial set-aside for Very Low Income Households. The underlying 0.5:1 FAR limitation is also prohibitive to a property granted unlimited height, thus preventing appropriate utilization of the Property for residential development consistent with R4 zoning standards. Therefore, this incentive for an increase of FAR is necessary to provide the building envelope and floor area needed for the Applicant to produce the cost reductions necessary to accommodate the Project's 18 units dedicated to Very Low Income households.

Granting the request for a decrease in this rear yard will allow for an expanded building envelope and the provision of additional market rate units which will offset the cost of the inclusion of restricted affordable units. Additionally, the decrease in the required rear yard will allow for a building footprint that is consistent with other buildings in the area, and make the provision of additional affordable units feasible by enabling parking on the first and second level as opposed to in costly subterranean levels that would render the provision of affordable units financially infeasible. The rear-yard decrease is thus necessary to provide the additional units which creates cost reductions enabling the Applicant to construct a housing project with 17% of the base density set aside for Very Low Income households. Additionally, the decrease in yard will allow the Project to accommodate street activating commercial uses and parking at the first and second floors that ensure the Project will be compatible with the surrounding community, and make the Project economically feasible in the long-term.

Granting the request for a decrease in this side yard will allow for an expanded building envelope which maximizes space along the street frontage. The maximization of this space will allow for the provision of market rate units that offset the cost of restricted affordable units. The configuration of the building to allow a 0 foot yard will ensure that commercial space is appropriately oriented toward the street, enhancing the marketability of market rate units and ensuring the economic viability of the Project. This will in turn allow the developer to provide such a substantial set-aside of affordable units. Additionally as noted above, an increase in the building footprint will make the provision of additional affordable units feasible by enabling parking on the first and second level as opposed to in costly subterranean levels that would render the provision of affordable units financially infeasible. The side-yard decrease is thus necessary to provide additional market rate units which creates cost reductions for the project, enabling the Applicant to construct a housing project with 17% of the base density set aside for Very Low Income households.

2.5 Conclusion

For all the foregoing reasons, the Project would be consistent with the applicable goals, policies, and objectives of the City's general land use plans and zoning for the Project Site.

The Project is consistent with the applicable general plan designation and all applicable general plan policies as well as with applicable zoning designation and regulations, and therefore, the Project would comply with CCR Section 15332(a).

3 Discussion of CCR Section 15332(b)

The proposed development occurs within city limits on a project site of no more than five acres substantially surrounded by urban uses.

The Project Site is located in an urbanized area of the City of Los Angeles. Urban land uses directly abut and surround the Project Site on all sides. The Project Site is bounded as follows:

North adjacent to the Site is a 2-story office building (currently occupied by Los Angeles County Department of Mental Health, Hollywood Mental Health Center, 1224 Vine Street). This area is zoned C2-1D.

South across Lexington Avenue is a fast food restaurant with drive-thru and surface parking lot (currently occupied by a Taco Bell, 6254 Lexington Avenue). This area is zoned C2-1D.

Southeast across Lexington Avenue are two 2-story residential buildings (6230, 6240 Lexington Avenue). This area is zoned RD1.5-1XL.

West across Vine Street is a 1-story banquet and event facility (currently occupied by the Taglyan Complex, 1201 Vine Street) and a vacant lot. This area is zoned C2-1D.

Southwest across Vine Street and Lexington Avenue is a 2-story vacant commercial building (1161 Vine Street) and a 2-story school building and outdoor play area (currently occupied by the Early Head Start, 1147 Vine Street). This area is zoned C2-1D.

East adjacent to the Site are two 2-story residential buildings (6232-6238 La Mirada Avenue and 6231-6239 Lexington Avenue). This area is zoned RD1.5-1XL.

As defined by CEQA Section 21071: *“Urbanized area” means either of the following: (a) An incorporated city that meets either of the following criteria: (1) Has a population of at least 100,000 persons. (2) Has a population of less than 100,000 persons if the population of that city and not more than two contiguous incorporated cities combined equals at least 100,000 persons.*

The Project Site measures 0.936 acres, which is less than five acres. The Project Site is located within the City of Los Angeles. Therefore, the development occurs within the City limits, is of no more than five acres, and is substantially surrounded by urban uses.

Therefore, the Project would comply with CCR Section 15332(b).

4 Discussion of CCR Section 15332(c)

The project site has no value as habitat for endangered, rare or threatened species.

This section is based on the following item, included as **Appendix B** of this CE:

B Tree Evaluation Report, Arborgate Consulting, June 21, 2022

4.1 Trees

There are 9 street trees on the sidewalk (4 jacarandas on Vine Street and 5 pink trumpet trees on Lexington Avenue). There are 3 onsite palm trees on the southwest corner of the parking lot.²⁰ None of the trees constitute a protected tree²¹ or shrub.²²

4.2 Habitat for Species

The Project Site is completely surrounded by urban uses. The Project Site contains two 1-story vacant commercial buildings and a surface parking lot.

The Project Site has been subject to substantial disturbance associated with the original construction of the building and ongoing regular maintenance of the landscaping and nearby surrounding areas are entirely developed. As such, the Project Site does not exhibit potential to support endangered, rare, or threatened plant species.

The Project Site is disturbed, relative to the presence of natural habitats, and surrounding areas are entirely developed; therefore, the Site does not provide potential habitat for endangered, rare, or threatened animal species. Some examples of these disturbances that deter animals include complete absence of native habitats or vegetation, substantial vehicle traffic, artificial lighting, regular vegetation maintenance, domesticated and feral dogs and cats, and pest management.

The California Natural Diversity Database (CNDDDB) identifies the following special-status community terrestrial habitats as occurring within the USGS Hollywood quadrangle²³: California Walnut Woodland, Southern Coast Live Oak Riparian Forest, Southern Cottonwood Willow Riparian Forest and Southern Sycamore Alder Riparian Woodland.²⁴

No special status community terrestrial habitats are present on the Project Site and there is no

²⁰ Tree Evaluation Report, Arborgate Consulting, June 21, 2022.

²¹ LAMC Section 46.01: "PROTECTED TREE" means any of the following Southern California native tree species which measures four inches or more in cumulative diameter, four and one-half feet above the ground level at the base of the tree: (a) Oak tree including Valley Oak (*Quercus lobata*) and California Live Oak (*Quercus agrifolia*), or any other tree of the oak genus indigenous to California but excluding the Scrub Oak (*Quercus dumosa*). (b) Southern California Black Walnut (*Juglans californica* var. *californica*) (c) Western Sycamore (*Platanus racemosa*) (d) California Bay (*Umbellularia californica*) This definition shall not include any tree grown or held for sale by a licensed nursery, or trees planted or grown as a part of a tree planting program.

²² Effective February 4, 2021 in Ordinance No 186,873, the City added Mexican elderberry and toyon shrubs to the list of protected species.

²³ US Geological Survey, Topographic Maps, Hollywood Quadrangle, 2022: <https://apps.nationalmap.gov/viewer/>

²⁴ California Department of Fish and Wildlife, BIOS Map: <https://wildlife.ca.gov/Data/CNDDDB/Maps-and-Data#43018410-cnddb-quickview-tool>

potential to occur.

4.3 Migratory Birds

Migratory nongame native bird species are protected by international treaty under the Federal Migratory Bird Treaty Act (MBTA) of 1918 (50 CFR Section 10.13). Sections 3503, 3503.5 and 3513 of the California Fish and Game Code prohibit take of all birds and their active nests including raptors and other migratory nongame birds (as listed under the Federal MBTA).

The City's Bureau of Street Services, Urban Forestry Division complies with the MBTA for tree pruning and tree removal.

The Project would comply with the regulations of the CDFW²⁵ and USFWS.²⁶

4.4 Wetlands and Riparian Areas

No federally protected wetlands (e.g., estuarine and marine deepwater, estuarine and marine, freshwater pond, lake, riverine) occur on or in the immediate vicinity of the Project Site.²⁷ The nearest wetland habitat is the Hollywood Forever Cemetery Lake, which classified as Freshwater Pond and located approximately 2,900 feet southeast of the Project Site.²⁸

No riparian or other sensitive habitat areas are located on or adjacent to the Project Site.²⁹

Due to the highly urbanized nature of the Project Site and surrounding area, the lack of a major water body, and the lack of trees (only palms), the Project Site is not a habitat for native resident or migratory species or contain native nurseries.

There are no City or County significant ecological areas on or around the Project Site.³⁰ There are no California Natural Community Conservation Plans (CNCCP) in the area. The only CNCCP in LA County is in the City of Rancho Palos Verdes.³¹

There are no Habitat Conservation Plans near the Site.³²

²⁵ <http://www.leginfo.ca.gov/html/fgctableofcontents.html>, accessed October 12, 2022.

²⁶ <https://www.fws.gov/birds/policies-and-regulations/laws-legislations/migratory-bird-treaty-act.php>, accessed October 12, 2022.

²⁷ USFWS, National Wetlands Inventory, Wetlands Mapper, website: <http://www.fws.gov/wetlands/Data/Mapper.html>, accessed October 12, 2022.

²⁸ USFWS, National Wetlands Inventory, Wetlands Layer: <http://www.fws.gov/wetlands/Data/Mapper.html>, accessed October 12, 2022.

²⁹ USFWS, National Wetlands Inventory, Wetlands Mapper, website: <http://www.fws.gov/wetlands/Data/Mapper.html>, accessed October 12, 2022.

³⁰ Navigate LA, Significant Ecological Areas layer: <http://navigatela.lacity.org/navigatela/>, accessed July 18, 2021.

³¹ California Natural Community Conservation Plans, April 2019, <https://nrm.dfg.ca.gov/FileHandler.ashx?DocumentID=68626&inline>, accessed October 12, 2022.

³² USFWS, Habitat Conservation Plans: <https://ecos.fws.gov/ecp0/conservationPlan/region/summary?region=8&type=HCP>, accessed October 12, 2022.

Thus, there exists no value for the Project Site as habitat for endangered, rare, or threatened species. Further, the Project Site is not located in an approved local, regional, or state habitat conservation plan.

4.5 Conclusion

The Project would not conflict with any local policies or ordinances protecting biological resources, or with the provisions of an adopted Habitat Conservation Plan. The Project Site has no value as habitat for endangered, rare, or threatened species.

Therefore, the Project would comply with CCR Section 15332(c).

5 Discussion of CCR Section 15332(d): Traffic

Approval of the project would not result in any significant effects relating to traffic, noise, air quality, or water quality.³³

This section is based on the following items, included as **Appendix C** of this CE:

C-1 Transportation Assessment, Gibson Transportation Consulting, November 2, 2022

C-2 Approval Letter, Los Angeles Department of Transportation, December 19, 2022

5.1 Construction

Pursuant to the LADOT guidance, construction impacts are considered part of the non-CEQA transportation analysis.³⁴ The discussion below is for informational purposes only.

Construction traffic would include worker trips and grading haul trips. Construction workers generally arrive at and depart from the worksite outside of peak traffic hours. The haul trips would occur during the permissible hauling hours identified by the Department of Building and Safety. Thus, it is not anticipated that construction traffic trips would contribute to a significant increase in the overall congestion in the Project Site vicinity. In addition, any truck trips would be limited to the length of time required for the Project's construction.

The grading phase would average approximately 45³⁵ haul trucks per day during the 45-day phase. Vine Street is a key part of the initial haul route for any soil exported from the Project Site Freeway, as trucks would then use Santa Monica Boulevard to access the Hollywood Freeway.

Project construction is not expected to create hazards for roadway travelers, bus riders, or parkers, so long as commonly practiced safety procedures for construction are followed. Such procedures and other measures (e.g., to address temporary traffic control, lane closures, sidewalk closures, etc.) would be incorporated into the Construction Management Plan.

Construction activities would be primarily contained within the Project Site boundaries. All construction equipment will be staged entirely on-site or delivered on an as needed basis. However, temporary closures of the public ROW (e.g., travel lanes, sidewalks) adjacent to the Project Site may be required during construction. Temporary traffic controls (e.g., use of directional signage, maintaining continuous and unobstructed pedestrian paths, and/or providing overhead covering) would be provided to direct traffic and/or pedestrians safely around any closures, as required in the Construction Management Plan.

The construction activities of the Project would require the temporary relocation of the Metro Local 210 stop located along Vine Street adjacent to the Project Site. The stop relocation would be

³³ Each of these topic areas (traffic, noise, air quality, and water quality) is discussed in its own section below.

³⁴ LADOT, Transportation Assessment Guidelines, August 2022. Project construction is categorized under Non-CEQA Transportation Analysis.

³⁵ 10,000 cubic yards export / 10 cy truck capacity / x 2 (for round trip) = 2,000 truck trips in total / 45 day = 45 truck trips per day

coordinated with Metro. Metro would be notified should the Project construction affect any other Metro facilities.

Parking is not permitted along Vine Street adjacent to the Project Site. It is, however, permitted along Lexington Avenue adjacent to the Project Site where construction activities may result in a temporary removal of up to five unmetered parking spaces. As such, coordination with LADOT would be included in the Construction Management Plan.

Typically, LADOT recommends that a construction work site traffic control plan be submitted to LADOT's Citywide Temporary Traffic Control Section or Permit Plan Review Section for review and approval prior to the start of any construction work. The plan should show the location of any roadway or sidewalk closures, traffic detours, haul routes, hours of operation, protective devices, warning signs and access to abutting properties. LADOT also recommends that all construction related truck traffic be restricted to off-peak hours to the extent feasible.

5.2 Operation

LADOT's Transportation Assessment Guidelines (August 2022) (TAG) provides screening criteria to determine whether traffic analysis is required under the California Environmental Quality Act (CEQA). CEQA analysis is based on vehicle miles traveled (VMT) that could be generated by the Project. The TAG states that a development project requires preparation of a transportation assessment if it is estimated to generate a net increase of 250 or more daily vehicle trips and requires discretionary action by the City. The Project would require a discretionary action. The Project trip generation was estimated to determine whether the other half of the criteria is satisfied.

The TAG allows the use of LADOT's VMT Calculator tool (version 1.3, released July 2020) to estimate daily trips for the purpose of screening a development project. The VMT Calculator is programmed with trip generation rates from Trip Generation Manual, 9th Edition (Institute of Transportation Engineers [ITE], 2012). It also applies various adjustment factors based on the Project's proximity to transit, surrounding density of development, etc. It considers trips generated by the proposed uses and discounts trips generated by existing or recently operating uses that would be removed from the Project Site.

Table 5-1 summarizes daily trip generation for the Project. This includes the Project; no credit is being applied for any existing uses, as the uses to be removed are vacant. As shown, the Project would generate 1,025 net trips without any TDM strategies. Therefore, based on the City threshold of 250 trips, a transportation assessment would be required for the Project.

5.2.1 Methodology

Two categories of transportation analysis are required by the City as detailed in the Transportation Assessment Guidelines (LADOT, August 2022) (TAG). The first category relates to potential transportation impacts under the California Environmental Quality Act (CEQA). Should a project exceed thresholds identified in the TAG, its impact would be considered significant under CEQA and would require implementation of feasible mitigation measures to reduce the impact below the threshold of significance. The CEQA thresholds identified in the TAG are consistent with City thresholds and with State of California (State) CEQA guidance. The second category is non-CEQA impacts.

- T-1 Conflicting with Plans, Programs, Ordinances or Policies
- T-2.1 Causing Substantial Vehicle Miles Traveled (VMT)
- T-2.2 Substantially Inducing Additional Automobile Travel Analysis
- T-3 Substantially Increasing Hazards Due to a Geometric Design Feature or Incompatible Use

**Table 5-1
Trip Generation Estimates**

Land Use	Size	Daily Vehicle Trips
Existing Uses (removed)		
Vacant ¹	-	-
Proposed Project		
Multi-Family Housing (Mid-Rise)	135 units	1,025
Multi-Family Housing (Affordable)	178 units	
High-Turnover Sit-Down Restaurant	7,000 sf	
Net total		1,025
¹ It should be noted that, to provide a more conservative analysis, no trip generation reductions were applied for the removal of existing uses at the Project Site. Affordable Housing trip generation rates from Los Angeles Department of Transportation (LADOT) Transportation Guidelines, Table 3.3-2: Trip Generation Rates for Affordable Housing Projects, August 2022. Trip generation rates "Inside TPA Area" were utilized. Utilizing the City of Los Angeles' VMT Calculator Tool (version 1.3). Transportation Assessment, Gibson Transportation Consulting, November 2, 2022.		

5.2.2 Conflict with Plans, Programs, Ordinances or Policies

To guide the City's Mobility Plan 2035, the City adopted programs, plans, ordinances, and policies that establish the transportation planning framework for all travel modes, including vehicular, transit, bicycle, and pedestrian facilities. Land development projects shall be evaluated for conformance with these City adopted transportation plans, programs, and policies.

The Project location and site access is consistent with the goals of the Mobility Plan as the Project would be designed to provide safe access for all users. The Project would support the policies of the Mobility Plan as it would promote a balanced transportation system by locating affordable housing in proximity to transit, jobs, and local retail uses. The Project would meet the goals of the Mobility Plan and would not interfere with the applicable policies of the Mobility Plan. Thus, the Project would be consistent with the Mobility Plan.

The Project supports healthy lifestyles by reducing single-occupant vehicle trips by virtue of its location near to abundant high-quality and high-frequency transit options and its provision of bicycle parking per the LAMC. The Project does not interfere with any other policies recommended by the plan. Therefore, the Project is consistent with Plan for a Healthy Los Angeles.

LAMC Section 12.21.A.16 details the bicycle parking requirements for new developments. In accordance with the requirements of the LAMC, the Project would provide a total 120 bicycle parking spaces, including 14 short-term and 106 long-term bicycle parking spaces.

LAMC Section 12.26J, the adopted TDM Ordinance (1993), establishes TDM requirements for projects with at least 25,000 sf of non-residential gross floor area. The Project does not include non-residential floor area in excess of 25,000 sf and, therefore, the TDM Ordinance does not apply.

LAMC Section 12.37 pertains to development or expansion of buildings along Highways and Collector Streets and applies to streets designated Boulevard I, Boulevard II, Avenue I, Avenue II, and Avenue III in the Mobility Plan. Vine Street is a designated Avenue II in the Mobility Plan, and the Project would provide a 10-foot dedication for future ROW expansion. Thus, the Project would be consistent with the requirements of LAMC Section 12.37.

The primary goal of Vision Zero is to eliminate traffic deaths in the City by 2025. Vision Zero identifies the HIN, a network of streets where strategic investments will have the biggest impact in reducing death and severe injury. Annually developed Action Plans emphasize creating safe streets for all users, developing a culture of safety, adopting policy measures to promote safety, and using data to inform the most effective solutions.

Adjacent to the Project Site, Vine Street has been identified as part of the High Injury Network, but has not been identified as a Priority Corridor. Therefore, no Vision Zero improvements are currently planned adjacent to the Project Site. Nevertheless, the Project would not preclude future Vision Zero safety improvements by the City. Thus, the Project does not conflict with Vision Zero.

Citywide Design Guidelines (LADCP Urban Design Studio, October 2019) identifies urban design principles to guide architects and developers in designing high-quality projects that meet the City's functional, aesthetic, and policy objectives and help foster a sense of community. Citywide Design Guidelines is organized around six design objectives. City of Los Angeles Urban Design Principles (LADCP, 2011) aims to improve mobility in the City through travel mode choices.

The Project would provide affordable housing in proximity to a broad range of land uses and transit options within walking distance, which would encourage pedestrian activity. The Project would be integrated within the surrounding area by providing improved sidewalks and landscaping. Pedestrian connections would be provided via separate entrances from vehicle entrances. In addition, loading activities would occur on-site. Therefore, the Project would align with Citywide Design Guidelines to provide a safe, comfortable, and accessible experience for all transportation modes.

Therefore, the Project does not have a significant transportation impact under CEQA Threshold T-1.1 (Conflicting with Plans, Programs, Ordinances or Policies).

5.2.2 Cause Substantial Vehicle Miles Traveled

As shown in **Table 5-2**, the VMT Calculator estimates that the Project would generate 695 proposed daily VMT. Utilizing the City's VMT Calculator Tool (V1.3), the VMT analysis for the Project was prepared. The Project's proposed land uses along with the existing land use were input into the City's VMT Calculator Tool.

The VMT Calculator was used to evaluate Project VMT and compare it to the VMT impact criteria. It should be noted that as part of the Project design, measures would be implemented to reduce the number of single occupancy vehicle trips to the Project Site. For the purposes of this analysis,

the VMT evaluation accounted for a reduced parking supply from baseline LAMC requirements and the inclusion of short-term and long-term bicycle parking per LAMC requirements.

As shown in **Table 5-2**, the VMT Calculator estimates that the Project would generate 1,320 total household VMT. Thus, based on the population assumptions, the Project would generate an average household VMT per capita of 3.7, which would not exceed the significance thresholds for the Central APC (6.0 household VMT per capita). Therefore, the Project would not result in a significant household VMT impact, and no mitigation measures would be required.

Therefore, the Project does not have a significant transportation impact under CEQA Threshold T-2.1 (Causing Substantial VMT).

Table 5-2
VMT Analysis Summary

Daily Vehicle Trips	Daily VMT	Household VMT			Work VMT		
		Per Capita	Threshold	Impact?	Per Capita	Threshold	Impact?
892	5,297	3.7	6.0	No	-	7.6	No
<p>VMT results based on the City of Los Angeles VMT Calculator Version 1.3 (July 2020). The maximum allowable VMT reduction is based on the Project's designated TBZ as determined in Transportation Demand Management Strategies in LA VMT Calculator (LADOT, November 2019) and Quantifying Greenhouse Gas Mitigation Measures (California Air Pollution Control Officers Association, 2010). Per the TAG, retail and restaurant uses totaling less than 50,000 sf would be considered local-serving and would have a negligible impact on regional VMT. Therefore, the VMT impact of the Project's commercial component would be considered less-than-significant. Reduced parking supply and the provision of bike parking per LAMC are included as Project design features. Based on home-based production trips only (see Appendix D, Report 4). <u>Transportation Assessment</u>, Gibson Transportation Consulting, November 2, 2022.</p>							

5.2.3 Substantially Inducing Additional Automobile Travel Analysis

The Project does not include additional through traffic lanes on existing or new highways, general purpose lanes, high-occupancy vehicle lanes, peak period lanes, auxiliary lanes, or lanes through grade-separated interchanges. Accordingly, neither the Project nor any improvements associated with it are considered a transportation project. Therefore, Threshold T-2.2 does not apply to the Project and no further evaluation is required.

5.2.4 Substantially Increasing Hazards Due to a Geometric Design Feature of Incompatible Use

Vehicular access to the Project Site would be provided via one commercial driveway on Vine Street, a designated Avenue II, with right-turn-only ingress/egress and one full access residential driveway on Lexington Avenue, a designated Local Street. Both driveways would be designed in accordance with City standards. Adequate queuing areas would also be provided at the driveways internal to the Project Site to limit any potential spillover into the public streets. Therefore, as detailed above, the vehicular access and internal circulation plan for the Project would be designed to minimize vehicular conflicts, and safety impacts to the abutting street system are not anticipated.

Pedestrian and bicycle access to the Project would be provided via commercial entrances along Vine Street and a residential lobby along Lexington Avenue. Vine Street has been identified as part of Vision Zero's HIN (High Injury Network) and the Mobility Plan's PED (Pedestrian Enhanced District) and BLN (Bicycle Lane Network). Vine Street also has Class III bicycle sharrows.

The driveways would be designed to provide safe pedestrian and bicycle crossings and, therefore, would not pose any safety hazards.

Therefore, the Project does not have a significant transportation impact under CEQA Threshold T-3 (Substantially Increasing Hazards Due to a Geometric Design Feature).

5.3 Conclusion

LADOT confirms that the Project would not have a significant transportation impact.³⁶

For all the foregoing reasons, the Project would not have a significant traffic impact and satisfies the requirement in CCR Section 15332(d) related to traffic.

³⁶ [Approval Letter](#), Los Angeles Department of Transportation, December 19, 2022.

6 Discussion of CCR Section 15332(d): Noise

Approval of the project would not result in any significant effects relating to traffic, noise, air quality, or water quality.³⁷

This section is based on the following item, included as **Appendix D** of this CE:

D Noise Technical Modeling, DKA Planning, October 2022

6.1 Fundamentals of Noise

6.1.1 Characteristics of Sound

Sound can be described in terms of its loudness (amplitude) and frequency (pitch). The standard unit of measurement for sound is the decibel (i.e., dB). Because the human ear is not equally sensitive to sound at all frequencies, the A-weighted scale (dBA) is used to reflect the normal hearing sensitivity range. On this scale, the range of human hearing extends from 3 to 140 dBA. **Table 6-1** provides examples of A-weighted noise levels from common sources.

Table 6-1
A-Weighted Decibel Scale

Typical A-Weighted Sound Levels	Sound Level (dBA L_{eq})
Near Jet Engine	130
Rock and Roll Band	110
Jet flyover at 1,000 feet	100
Power Motor	90
Food Blender	80
Living Room Music	70
Human Voice at 3 feet	60
Residential Air Conditioner at 50 feet	50
Bird Calls	40
Quiet Living Room	30
Average Whisper	20
Rustling Leaves	10
Source: Cowan, James P., Handbook of Environmental Acoustics, 1993. These noise levels are approximations intended for general reference and informational use.	

6.1.2 Noise Definitions

This noise analysis discusses sound levels in terms of equivalent noise level (L_{eq}), maximum noise level (L_{max}) and the Community Noise Equivalent Level (CNEL).

³⁷ Each of these topic areas (traffic, noise, air quality, and water quality) is discussed in its own section.

- **Equivalent Noise Level (L_{eq}):** L_{eq} represents the average noise level on an energy basis for a specific time period. Average noise level is based on the energy content (acoustic energy) of sound. For example, the L_{eq} for one hour is the energy average noise level during that hour. L_{eq} can be thought of as a continuous noise level of a certain period equivalent in energy content to a fluctuating noise level of that same period.
- **Maximum Noise Level (L_{max}):** L_{max} represents the maximum instantaneous noise level measured during a given time period.
- **Community Noise Equivalent Level (CNEL):** CNEL is an adjusted noise measurement scale of average sound level during a 24-hour period. Due to increased noise sensitivities during evening and night hours, human reaction to sound between 7:00 P.M. and 10:00 P.M. is as if it were actually 5 dBA higher than had it occurred between 7:00 A.M. and 7:00 P.M. From 10:00 P.M. to 7:00 A.M., humans perceive sound as if it were 10 dBA higher. To account for these sensitivities, CNEL figures are obtained by adding an additional 5 dBA to evening noise levels between 7:00 P.M. and 10:00 P.M. and 10 dBA to nighttime noise levels between 10:00 P.M. and 7:00 A.M. As such, 24-hour CNEL figures are always higher than their corresponding actual 24-hour averages.

6.1.3 Effects of Noise

The degree to which noise can impact an environment ranges from levels that interfere with speech and sleep to levels that can cause adverse health effects. Most human response to noise is subjective. Factors that influence individual responses include the intensity, frequency, and pattern of noise; the amount of background noise present; and the nature of work or human activity exposed to intruding noise.

According to the National Institute of Health (NIH), extended or repeated exposure to sounds above 85 dB can cause hearing loss. Sounds less than 75 dBA, even after continuous exposure, are unlikely to cause hearing loss.³⁸ The World Health Organization (WHO) reports that adults should not be exposed to sudden “impulse” noise events of 140 dB or greater. For children, this limit is 120 dB.³⁹

Exposure to elevated nighttime noise levels can disrupt sleep, leading to increased levels of fatigue and decreased work or school performance. For the preservation of healthy sleeping environments, the WHO recommends that continuous interior noise levels not exceed 30 dBA, L_{eq} and that individual noise events of 45 dBA or higher be limited.⁴⁰ Assuming a conservative exterior to interior sound reduction of 15 dBA, continuous exterior noise levels should therefore not exceed 45 dBA L_{eq} . Individual exterior events of 60 dBA or higher should also be limited. Some epidemiological studies have shown a weak association between long-term exposure to noise levels of 65 to 70 dBA, L_{eq} and cardiovascular effects, including ischaemic heart disease and hypertension. However, at this time, the relationship is largely inconclusive.

³⁸ National Institute of Health, National Institute on Deafness and Other Communication, www.nidcd.nih.gov/health/noise-induced-hearing-loss.

³⁹ World Health Organization, Guidelines for Community Noise, 1999.

⁴⁰ World Health Organization, Guidelines for Community Noise, 1999.

People with normal hearing sensitivity can recognize small perceptible changes in sound levels of approximately 3 dBA while changes of 5 dBA can be readily noticeable. Sound level increases of 10 dBA or greater are perceived as a doubling in loudness and can provoke a community response.⁴¹ However, few people are highly annoyed by noise levels below 55 dBA L_{eq} .⁴²

Noise Attenuation. Noise levels decrease as the distance from noise sources to receivers increases. For each doubling of distance, noise from stationary sources can decrease by about 6 dBA over hard surfaces (e.g., reflective surfaces such as parking lots) and 7.5 dBA over soft surfaces (e.g., absorptive surfaces such as soft dirt and grass). For example, if a point source produces a noise level of 89 dBA at a reference distance of 50 feet and over an asphalt surface, its noise level would be approximately 83 dBA at a distance of 100 feet, 77 dBA at 200 feet, etc. Noises generated by mobile sources such as roadways decrease by about 3 dBA over hard surfaces and 4.5 dBA over soft surfaces for each doubling of distance. It should be noted that because decibels are logarithmic units, they cannot be added or subtracted. For example, two cars each producing 60 dBA of noise would not produce a combined 120 dBA.

Noise is most audible when traveling by direct line of sight, an unobstructed visual path between noise source and receptor. Barriers that break line of sight between sources and receivers, such as walls and buildings, can greatly reduce source noise levels by allowing noise to reach receivers by diffraction only. As a result, sound barriers can generally reduce noise levels by up to 15 dBA.⁴³ The effectiveness of barriers can be greatly reduced when they are not high or long enough to completely break line of sight from sources to receivers.

6.2 Regulatory Framework

6.2.1 Federal

Currently, no federal noise standards regulate environmental noise associated with short-term construction activities or long-term operations of development projects. As such, temporary and long-term noise impacts produced by the Project would be largely regulated or evaluated by State and City of Los Angeles standards designed to protect public well-being and health.

6.2.2 State

6.2.2.1 2017 General Plan Guidelines

The State's 2017 General Plan Guidelines establish county and city standards for acceptable exterior noise levels based on land use. These standards are incorporated into land use planning processes to prevent or reduce noise and land use incompatibilities. **Table 6-2** illustrates State compatibility considerations between various land uses and exterior noise levels.

California Government Code Section 65302 also requires each county and city to prepare and adopt a comprehensive long-range general plan for its physical development. Section 65302(f) requires a noise element to be included in the general plan. This noise element must identify and

⁴¹ Federal Transit Administration, Transit Noise and Vibration Impact Assessment, 2018.

⁴² World Health Organization, Guidelines for Community Noise, 1999.

⁴³ California Department of Transportation, Technical Noise Supplement to the Traffic Noise Analysis Protocol, September 2013.

appraise noise problems in the community, recognize Office of Noise Control guidelines, and analyze and quantify current and projected noise levels.

The State has also established noise insulation standards for new multi-family residential units, hotels, and motels that are subject to relatively high levels of noise from transportation. The noise insulation standards, collectively referred to as the California Noise Insulation Standards (Title 24, California Code of Regulations) set forth an interior standard of 45 dBA CNEL for habitable rooms. The standards require an acoustical analysis which indicates that dwelling units meet this interior standard where such units are proposed in areas subject to exterior noise levels greater than 60 dBA CNEL. Local jurisdictions typically enforce the California Noise Insulation Standards through the building permit application process.

**Table 6-2
State of California Noise/Land Use Compatibility Matrix**

Land Use Compatibility	Community Noise Exposure (dBA, CNEL)							
	<	55	60	65	70	75	80	>
Residential – Low Density Single-Family, Duplex Mobile Homes	NA							
		CA						
					NU			
Residential – Multi-Family	NA							
		CA						
					NU			
Transient Lodging – Motels, Hotels	NA							
		CA						
					NU			
Schools, Libraries, Churches, Hospitals, Nursing Homes	NA							
		CA						
					NU			
		CA						
Sports Arenas, Outdoor Spectator Sports								
	CA							
					NU			
Playgrounds, Neighborhood Parks	NA							
					NU			
Golf Courses, Riding Stables, Water Recreation, Cemeteries	NA							
					NU			
Office Buildings, Business Commercial and Professional	NA							
					CA			
							NU	
Industrial, Manufacturing, Utilities, Agriculture	NA							
					CA			
							NU	

NA = Normally Acceptable - Specified land use is satisfactory, based upon the assumption that any buildings involved are of normal conventional construction without any special noise insulation requirements.

CA = Conditionally Acceptable - New construction or development should be undertaken only after a detailed analysis of the noise reduction requirements is made and needed noise insulation features included in the design. Conventional construction, but with closed windows and fresh air supply system or air conditioning will normally suffice.

NU = Normally Unacceptable - New construction or development should generally be discouraged. If new construction or development does proceed, a detailed analysis of the noise reduction requirements must be made and needed noise insulation features included in the design.

CU = Clearly Unacceptable - New construction or development should generally not be undertaken.

Source: CA Office of Planning and Research, General Plan Guidelines - Noise Element Guidelines (Appendix D), Figure 2, 2017.

6.2.3 County

6.2.3.1 County Airport Land Use Commission Comprehensive Land Use Plan

In Los Angeles County, the Regional Planning Commission has the responsibility for acting as the Airport Land Use Commission and for coordinating the airport planning of public agencies within the County. The Airport Land Use Commission coordinates planning for the areas surrounding public use airports. The Comprehensive Land Use Plan provides for the orderly expansion of Los Angeles County's public use airports and the areas surrounding them. It is intended to provide for the adoption of land use measures that will minimize the public's exposure to excessive noise and safety hazards. In formulating the Comprehensive Land Use Plan, the Los Angeles County Airport Land Use Commission has established provisions for safety, noise insulation, and the regulation of building height within areas adjacent to each of the public airports in the County.

6.2.4 City of Los Angeles

6.2.4.1 General Plan Noise Element

The City of Los Angeles General Plan includes a Noise Element that includes policies and standards in order to guide the control of noise to protect residents, workers, and visitors. Its primary goal is to regulate long-term noise impacts to preserve acceptable noise environments for all types of land uses. There are also references to programs applicable to construction projects that call for protection of noise sensitive uses and use of best practices to minimize short-term noise impacts. However, the Noise Element contains no quantitative or other thresholds of significance for evaluating a project's noise impacts. Instead, it adopts the State's guidance on noise and land use compatibility, shown in **Table 6-2** above, "to help guide determination of appropriate land use and mitigation measures vis-à-vis existing or anticipated ambient noise levels."

It also includes the following objective and policy that are relevant for the Project:

Objective 2 (Non-airport): *Reduce or eliminate non-airport related intrusive noise, especially relative to noise sensitive uses.*

Policy 2.2: *Enforce and/or implement applicable city, state, and federal regulations intended to mitigate proposed noise producing activities, reduce intrusive noise and alleviate noise that is deemed a public nuisance.*

6.2.4.2 Los Angeles Municipal Code

The City of Los Angeles Municipal Code (LAMC) contains regulations that would regulate noise from the Project's temporary construction activities.

Section 41.40(a) would prohibit specific Project construction activities from occurring between the hours of 9:00 P.M. and 7:00 A.M., Monday through Friday. Subdivision (c) would further prohibit such activities from occurring before 8:00 A.M. or after 6:00 P.M. on any Saturday or national holiday, or at any time on any Sunday. These restrictions serve to limit specific Project construction activities to Monday through Friday 7:00 A.M. to 9:00 P.M., and 8:00 A.M. to 6:00 P.M. on Saturdays or national holidays.

Section 112.05 of the LAMC establishes noise limits for powered equipment and hand tools operated in a residential zone or within 500 feet of any residential zone. Of particular importance to construction activities is subdivision (a), which institutes a maximum noise limit of 75 dBA as measured at a distance of 50 feet from the activity for the types of construction vehicles and equipment that would likely be used in the construction of the Project. However, the LAMC notes that these limitations would not necessarily apply if it can be proven that the Project's compliance would be technically infeasible despite the use of noise-reducing means or methods.

In addition, the LAMC regulates long-term operations of land uses, including but not limited to the following regulations.

Section 111.02 discusses the measurement procedure and criteria regarding the sound level of "offending" noise sources. A noise source causing a 5 dBA increase over the existing average ambient noise levels of an adjacent property is considered to create a noise violation. However, Section 111.02(b) provides a 5 dBA allowance for noise sources lasting more than five but less than 15 minutes in any 1-hour period, and a 10 dBA allowance for noise sources causing noise lasting 5 minutes or less in any 1-hour period. In accordance with these regulations, a noise level increase from certain city-regulated noise sources of five dBA over the existing or presumed ambient noise level at an adjacent property is considered a violation.

Section 112.01 of the LAMC would prohibit any amplified noises, especially those from outdoor sources (e.g., outdoor speakers, stereo systems) from exceeding the ambient noise levels of adjacent properties by more than 5 dBA. Any amplified noises would also be prohibited from being audible at any distance greater than 150 feet from the Project's property line, as the Project is located within 500 feet of residential zones.

Section 112.02 would prevent Project heating, ventilation, and air conditioning (HVAC) systems and other mechanical equipment from elevating ambient noise levels at neighboring residences by more than 5 dBA.

The LAMC also provides regulations regarding vehicle-related noise, including Sections 114.02, 114.03, and 114.06. Section 114.02 prohibits the operation of any motor driven vehicles upon any property within the City in a manner that would cause the noise level on the premises of any

occupied residential property to exceed the ambient noise level by more than 5 dBA. Section 114.03 prohibits loading and unloading causing any impulsive sound, raucous or unnecessary noise within 200 feet of any residential building between the hours of 10 P.M. and 7 A.M. Section 114.06 requires vehicle theft alarm systems to be silenced within five minutes.

6.3 Existing Conditions

6.3.1 Noise-Sensitive Receptors

The City considers the following noise-sensitive uses: residences, transient lodgings (hotels), schools, libraries, churches, hospitals, nursing homes, auditoriums, concert halls, amphitheaters, playgrounds, and parks. The Project Site is located on the Vine Street commercial corridor in the Hollywood neighborhood. Sensitive receptors within 0.25 miles of the Project Site include, but are not limited to, the following representative sampling:

- Mental Health Center, 1224 Vine Street, directly north of the Project Site.
- Residences, 6232-6238 La Mirada Avenue, five feet east of the Project Site.
- Residences, 6231-6239 Lexington Avenue, five feet east of the Project Site.
- Residences, 6236-6240 Lexington Avenue, 80 feet south of the Project Site.
- Taglyan Complex special event center, 1201 Vine Street, 90 feet west of the Project Site.
- Early Head Start School, 1147 Vine Street, 160 feet southwest of the Project Site.
- Hotel (residential rentals), 6326 Lexington Avenue, 230 feet west of the Project Site.
- Hampton Inn & Suites Hotel, 1133 Vine Street; 300 feet southwest of the Project Site.
- Episcopal School of Los Angeles, 6235 Santa Monica Boulevard, 585 feet southwest of the Project Site.
- Vine Street Elementary School, 955 Vine Street, 1,350 feet southwest of the Project Site.

6.3.2 Existing Ambient Noise Levels

The Project Site is occupied by two buildings totaling 27,011 square feet and a 16,000 square-foot surface parking lot. As both buildings are vacant, there is no noise generated at the Project Site. Traffic is the primary source of noise near the Project Site, largely from the operation of vehicles with internal combustion engines and frictional contact with the ground and air. This includes traffic on Vine Street, which carries 2,552 north- and south-bound vehicles at Lexington Avenue in the A.M. peak hour.⁴⁴

⁴⁴ Gibson Transportation Consulting, Inc. [Transportation Assessment](#) for the 1200 Vine Street Project; November 2, 2022.

In September 2022, DKA Planning took short-term noise measurements near the Project site to determine the ambient noise conditions of the neighborhood near sensitive receptors.⁴⁵ As shown in **Table 6-3**, noise levels along roadways near the Project Site ranged from 57.6 to 68.1 dBA L_{eq}, which was generally consistent with the traffic volumes on Lexington Avenue and Vine Street, respectively.

Figure 6-1 illustrates where ambient noise levels were measured near the Project Site to establish the noise environment and their relationship to the applicable sensitive receptor(s). 24-hour CNEL noise levels are generally considered “Normally Acceptable” and “Conditionally Acceptable” for the types of land uses near the Project Site.

Figure 6-1
Noise Monitoring Locations

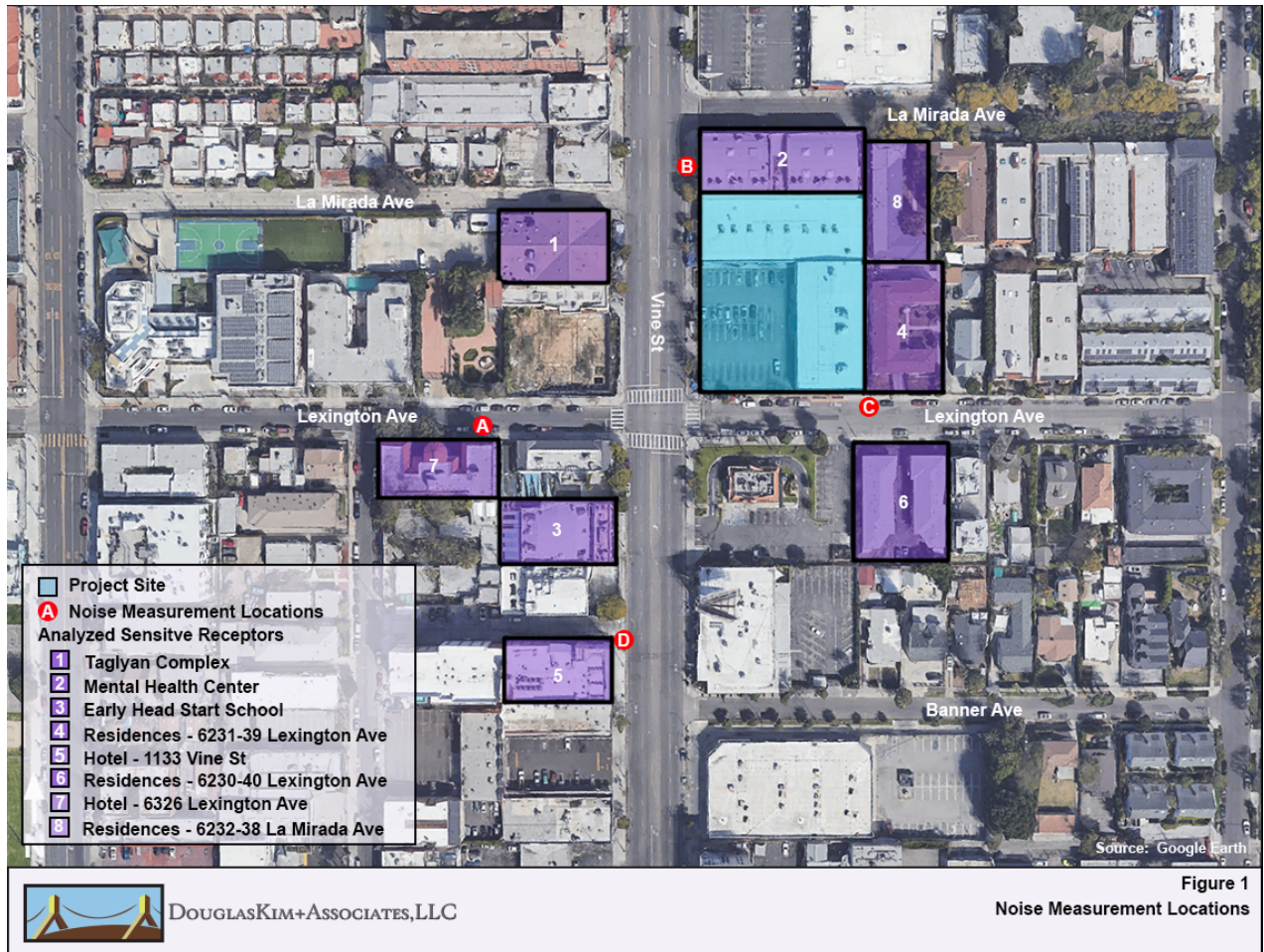

⁴⁵ Noise measurements were taken using a Quest Technologies Sound Examiner SE-400 Meter. The Sound Examiner meter complies with the American National Standards Institute (ANSI) and International Electrotechnical Commission (IEC) for general environmental measurement instrumentation. The meter was equipped with an omni-directional microphone, calibrated before the day’s measurements, and set at approximately five feet above the ground.

**Table 6-3
Existing Noise Levels**

Noise Measurement Locations	Primary Noise Source	Sound Levels		Nearest Sensitive Receptor(s)	Noise / Land Use Compatibility ^b
		dBA (L _{eq})	dBA (CNEL) ^a		
A. 6326 Lexington Ave.	Traffic on Lexington Ave.	57.6	55.6	Hotel, 6326 Lexington Ave.	Normally Acceptable
B. 1224 Vine St.	Traffic on Vine St.	68.1	66.1	Mental Health Center; Taglyan Complex	Conditionally Acceptable
C. 6239 Lexington Ave.	Traffic on Lexington Ave.	59.5	57.5	Residences, 6231-39, 6236-40 Lexington Ave; 6232-38 La Mirada Ave.	Normally Acceptable
D. Hampton Inn & Suites	Traffic on Vine St.	66.7	64.7	Early Head Start School; Hotel, 1133 Vine St.	Conditionally Acceptable

^a Estimated based on short-term (15-minute) noise measurement using Federal Transit Administration procedures from 2016 Transit Noise and Vibration Impact Assessment Manual, Appendix E, Option 4.
^b Pursuant to California Office of Planning and Research “General Plan Guidelines, Noise Element Guidelines, 2017. When noise measurements apply to two or more land use categories, the more noise-sensitive land use category is used. See Table 6-2 above for definition of compatibility designations.
Source: DKA Planning, 2022.

6.4 Methodology

6.4.1 On-Site Construction Activities

Construction noise levels at nearby sensitive receptors were modeled employing the ISO 9613-2 sound attenuation methodologies using the SoundPLAN Essential model (version 5.1). This software package considers reference equipment noise levels, noise management techniques, distance to receptors, and any attenuating features to predict noise levels from sources like construction equipment. The distance from construction equipment noise sources (e.g., engines and tailpipes) assume that vehicles would not be capable of operating directly where the Project’s property line abuts adjacent structures. These vehicles would retain some setback to preserve maneuverability, in addition to operating at reduced power and intensity to maintain precision at these locations.

6.4.2 Off-Site Construction Activities

The Project’s off-site construction noise impact from haul trucks was analyzed by considering the Project’s estimated haul truck usage with existing traffic and roadway noise levels along the Project’s anticipated haul route. Because it takes a doubling of traffic volumes on a roadway to generate the increased sound energy it takes to elevate ambient noise levels by 3 dBA,⁴⁶ the analysis focused on whether truck traffic would double traffic volumes on key roadways to be used for hauling soils to and/or from the Project Site during construction activities. Because haul trucks generate more noise than traditional passenger vehicles, a 19.1 passenger car equivalency (PCE) was used to convert haul truck trips to a reference level conversion to an equivalent number

⁴⁶ Federal Transit Administration, Transit Noise and Vibration Impact Assessment Manual, September 2018.

of passenger vehicles.⁴⁷ It should be noted that because an official haul route has not been approved as of the preparation of this analysis, assumptions were made about logical routes that would minimize haul truck traffic on local streets in favor of major arterials that can access regional-serving freeways.

Similarly, off-site noise impacts from vendors and employees that access the construction site were also analyzed. The analysis focused on whether truck traffic would double traffic volumes on key roadways to be used for hauling soils during construction activities.

6.4.3 On-Site Operational Noise Sources

The Project's potential to result in significant noise impacts from on-site operational noise sources was evaluated by identifying sources of on-site noise sources and considering the impact that they could produce given the nature of the source (i.e., loudness and whether noise would be produced during daytime or more-sensitive nighttime hours), distances to nearby sensitive receptors, surrounding ambient noise levels, the presence of similar noise sources in the vicinity, and maximum allowable noise levels permitted by the LAMC.

6.4.4 Off-Site Operational Project Traffic Noise Sources

The Project's off-site noise impact from Project-related traffic was evaluated based its potential to increase traffic volumes on local roadways that serve the Project site. Because it takes a doubling of traffic volumes on a roadway to generate the increased sound energy it takes to elevate ambient noise levels by 3 dBA, the analysis focused on whether auto trips generated by the Project would double traffic volumes on key roadways to be used to access the Project Site.

6.5 Thresholds of Significance

6.5.1 State CEQA Guidelines

In accordance with CEQA Guidelines Section 15332(d), approval of the project would not result in any significant effects relating to noise.

6.5.2 Construction Noise Threshold

Based on guidelines from the City of Los Angeles City Department of Planning, the on-site construction noise impact would be considered significant if:

- Construction activities lasting more than one day would exceed existing ambient exterior sound levels by 10 dBA (hourly L_{eq}) or more at a noise-sensitive use;
- Construction activities lasting more than 10 days in a three-month period would exceed existing ambient exterior noise levels by 5 dBA (hourly L_{eq}) or more at a noise-sensitive use; or

⁴⁷ Caltrans, Technical Noise Supplement Table 3-3, 2013.

- Construction activities of any duration would exceed the ambient noise level by 5 dBA (hourly L_{eq}) at a noise-sensitive use between the hours of 9:00 P.M. and 7:00 A.M. Monday through Friday, before 8:00 A.M. or after 6:00 P.M. on Saturday, or at any time on Sunday.

6.5.3 Operational Noise Thresholds

In addition to applicable City standards and guidelines that would regulate or otherwise moderate the Project's operational noise impacts, the following criteria are adopted to assess the impact of the Project's operational noise sources:

- Project operations would cause ambient noise levels at off-site locations to increase by 3 dBA CNEL or more to or within “normally unacceptable” or “clearly unacceptable” noise/land use compatibility categories, as defined by the State's 2017 General Plan Guidelines.
- Project operations would cause any 5 dBA or greater noise increase.⁴⁸

6.6 Analysis of Project Impacts

6.6.1 Construction

6.6.1.1 On-Site Construction Activities

Construction would generate noise during the construction process that would span 35 months of demolition, grading, utilities trenching, building construction, and application of architectural coatings, as shown in **Table 6-4**. During all construction phases, noise-generating activities could occur at the Project Site between 7:00 A.M. and 9:00 P.M. Monday through Friday, in accordance with LAMC Section 41.40(a). On Saturdays, construction would be permitted to occur between 8:00 A.M. and 6:00 P.M.

Table 6-4
Construction Schedule Assumptions

Phase	Duration	Notes
Demolition	Months 1-3	Removal of 27,011 square feet of building floor area and 16,000 square feet of asphalt/concrete parking lot hauled 30 miles to landfill in 10-cubic yard capacity trucks.
Grading	Months 4-5	Approximately 10,000 cubic yards of soil (including swell factors for topsoil and dry clay) hauled 30 miles to landfill in 10-cubic yard capacity trucks. ⁴⁹
Trenching	Months 6-7 (6 weeks)	Trenching for utilities, including gas, water, electricity, and telecommunications.
Building Construction	Months 6-31	Footings and Foundation work (e.g., pouring concrete pads), framing, welding; installing mechanical, electrical, and

⁴⁸ As a 3 dBA increase represents a slightly noticeable change in noise level, this threshold considers any increase in ambient noise levels to or within a land use's “normally unacceptable” or “clearly unacceptable” noise/land use compatibility categories to be significant so long as the noise level increase can be considered barely perceptible. In instances where the noise level increase would not necessarily result in “normally unacceptable” or “clearly unacceptable” noise/land use compatibility, a readily noticeable 5 dBA increase is still to be significant. Increases less than 3 dBA are unlikely to result in noticeably louder ambient noise conditions and would therefore be less than significant.

⁴⁹ Estimates provided by the Applicant, July 2022. Assumes 8,439 cy with a soil swell percent of 18.5% = 10,000 cy.

**Table 6-4
Construction Schedule Assumptions**

Phase	Duration	Notes
		plumbing, floor assembly, cabinetry and carpentry, elevator installations, low voltage systems, trash management.
Architectural Coatings	Months 27-35	Application of interior and exterior coatings and sealants.

Source: DKA Planning, 2022.

Noise levels would generally peak during the demolition and grading phases, when diesel-fueled heavy-duty equipment (e.g., excavators, dozers) are needed to move large amounts of debris and dirt, respectively. This equipment is mobile in nature and does not always operate at in a steady-state mode full load, but rather powers up and down depending on the duty cycle needed to conduct work. As such, equipment is occasionally idle during which time no noise is generated. Mobile equipment will often operate away from off-site receptors, continuously moving around.

During other phases of construction (e.g., demolition, site preparation, building construction, architectural coatings), noise impacts are generally lesser because they are less reliant on using heavy equipment with internal combustion engines. Smaller equipment (e.g., forklifts, generators, powered hand tools, pneumatic equipment) would generally be utilized. Off-site secondary noises would be generated by construction worker vehicles, vendor deliveries, and haul trucks. **Figure 6-2** illustrates how noise would propagate from the construction site during the demolition and grading phase.

**Figure 6-2
Construction Noise Sound Contours**



Because the Project’s construction phase would occur for more than three months, the applicable City threshold of significance for the Project’s construction noise impacts is an increase of 5 dBA over existing ambient noise levels. As shown in **Table 6-5**, when considering ambient noise levels, the use of multiple pieces of powered equipment simultaneously would increase ambient noise negligibly. This assumes the use of best practices techniques required by the City’s Building and Safety code, such as temporary sound barriers. These construction noise levels would not exceed the City’s significance threshold of 5 dBA. Therefore, the Project’s on-site construction noise impact would be less than significant.

**Table 6-5
Construction Noise Impacts at Off-Site Sensitive Receptors**

Receptor	Maximum Construction Noise Level (dBA L _{eq})	Existing Ambient Noise Level (dBA L _{eq})	New Ambient Noise Level (dBA L _{eq})	Increase (dBA L _{eq})	Potentially Significant ?
1. Taglyan Complex	64.0	68.1	69.5	1.4	No
2. Mental Health Center	58.5	68.1	68.6	0.5	No
3. Early Head Start School	58.6	66.7	67.3	0.6	No
4. Residences – 6231-39 Lexington Ave.	61.4	59.5	63.6	4.1	No
5. Hotel – 1133 Vine St.	53.8	66.7	66.9	0.2	No
6. Residences – 6230-40 Lexington Ave.	60.9	59.5	63.3	3.8	No
7. Hotel – 6326 Lexington Ave.	56.9	57.6	60.3	2.7	No
8. Residences – 6232-38 La Mirada Ave.	49.2	59.5	59.9	0.4	No
Source: DKA Planning, 2022.					

6.6.1.2 Off-Site Construction Activities

The Project would also generate noise at off-site locations from haul trucks moving debris and soil from the Project Site during demolition and grading activities, respectively; vendor and contractor trips; and worker commute trips. Construction activities would generate up to an estimated 193 peak hourly PCE vehicle trips, as summarized in **Table 6-6**, during the building construction phase, assuming all workers travel to the worksite at the same time and that all worker trips, vendor trips, and haul trips use the same route to travel to and from the Project Site. This includes converting noise from heavy-duty truck trips to an equivalent number of passenger vehicle trips. This would represent about 7.6 percent of traffic volumes on Vine Street, which carries about 2,552 vehicles at Lexington Avenue in the morning peak hour of traffic.⁵⁰ Because workers, haulers, and vendors will likely use more than one route to travel to and from the Project Site, this conservative assessment of traffic volumes overstates the likely traffic volumes from construction activities at this intersection.

Vine Street is a key part of the initial haul route for any soil exported from the Project Site Freeway, as trucks would then use Santa Monica Boulevard to access the Hollywood Freeway. Because the Project’s construction-related trips would not cause a doubling in traffic volumes (i.e., 100

⁵⁰ Gibson Transportation Consulting, Inc. Transportation Assessment for the 1200 Vine Street Project; November 2, 2022.

percent increase) on Vine Street, the Project's construction-related traffic would not increase existing noise levels by 3 dBA or more. Therefore, the Project's noise impacts from construction-related traffic would be less than significant.

**Table 6-6
Construction Vehicle Trips (Maximum Hourly)**

Construction Phase	Worker Trips ^a	Vendor Trips	Haul Trips	Total (PCE)	Percent of Peak A.M. Hour Trips on Vine St. ^e
Demolition	10	0	36 ^b	46	1.8
Grading	8	0	121 ^c	129	5.0
Trenching	5	0	0	5	0.2
Building Construction	129	64 ^d	0	193	7.6
Architectural Coating	27	0	0	27	1.0

^a Assumes all worker trips occur in the peak hour of construction activity.
^b The project would generate 852 haul trips over a 64-day period with seven-hour work days. Because haul trucks emit more noise than passenger vehicles, a 19.1 passenger car equivalency (PCE) was used to convert haul truck trips to a passenger car equivalent.
^c The project would generate 2,000 haul trips over a 45-day period with seven-hour work days. Assumes a 19.1 PCE.
^d This phase would generate about 24 vendor truck trips daily over a seven-hour work day. Assumes a blend of vehicle types and a 9.55 PCE.
^e Percent of existing traffic volumes on Vine Street at Lexington Avenue.
Source: DKA Planning, 2022

6.6.2 Operation

6.6.2.1 On-Site Operational Noise Sources

During long-term operations, the Project would produce noise from both on- and off-site sources. As discussed below, the Project would not result in an exposure of persons to or a generation of noise levels in excess of standards established in the local general plan or noise ordinance, or applicable standards of other agencies. The Project would also not increase surrounding noise levels by more than 5 dBA CNEL, the minimum threshold of significance based on the noise/land use category of sensitive receptors near the Project Site. As a result, the Project's on-site operational noise impacts would be considered less than significant.

Mechanical Equipment. The Project would operate mechanical equipment throughout the roof that would generate incremental long-term noise impacts. HVAC equipment in the form of large rooftop units (RTUs) suitable for cooling large volumes of a building would be located on the rooftop, approximately 85 feet above grade. This equipment would include a number of sound sources, including compressors, condenser fans, supply fans, return fans, and exhaust fans that could generate a sound pressure level of up to 81.9 dBA at one foot.⁵¹

However, noise impacts from rooftop mechanical equipment on nearby sensitive receptors would be negligible for several reasons. First, there would be no line-of-sight from these rooftop units to

⁵¹ City of Pomona, Pomona Ranch Plaza WalMart Expansion Project, Table 4.4-5; August 2014. Source was cluster of mechanical rooftop condensers including two Krack MXE-04 four-fan units and one MXE-02 two-fan unit. Reference noise level based on 30 minutes per hour of activity.

the sensitive receptors. Because the residences adjacent to the Project Site are generally one- to two-stories in height, there would be no sound path from the HVAC equipment to residences and other receptors that would be up to 60 to 70 feet lower than the roof of the Project. Second, the presence of the Project's roof edge creates an effective noise barrier that further reduces noise levels from rooftop HVAC units by 8 dBA or more.⁵² A 3'-6" parapet would further shield sensitive receptors near the Project Site. These design elements would be helpful in managing noise, as equipment often operates continuously throughout the day and occasionally during the day, evenings, and weekends. Finally, the RTUs are set back substantially from the edges of those roofs, allowing for more attenuation of any noise. These units are set back almost 30 feet from the west edge of the roof, 20 feet from the north edge, and 25'6" from the east edge. When combined with the ten and eleven-foot building setbacks, respectively, these RTUs would be negligible additions to the noise environment at nearby receptors.

As a result, noise from HVAC units would negligibly elevate ambient noise levels, far less than the 5 dBA CNEL threshold of significance for operational impacts. Compliance with LAMC Section 112.02 would further limit the impact of HVAC equipment on noise levels at adjacent properties.

All other mechanical equipment would be fully enclosed within the structure, shielded from outside sources. This includes three mechanical equipment rooms and an electrical equipment rooms on the first and second floors of the above-ground parking garage. In addition, elevator equipment (including hydraulic pump, switches, and controllers) would be located on the ground floor of the parking garage structure.

Given the integration of these mechanical equipment facilities into the design of the structure, there would be no external noise impacts from these operational facilities and these operational noise impacts would be considered less than significant.

Auto-Related Activities. The majority of vehicle-related noise impacts at the Project Site would come from vehicles entering and exiting the development from a driveway off Vine Street for commercial workers and visitors and Lexington Avenue for residents and visitors. During the peak P.M. hour, approximately 54 vehicles would generate noise in and out of the residents' garage via the driveway off Lexington Avenue, with up to 54 vehicles using the garage in the peak A.M. hour.⁵³ Vehicles accessing the commercial garage would generate about 41 vehicle trips from the driveway off Vine Street in the peak P.M. hour and 43 net trips in the A.M. peak hour.

Two sensitive receptors near the Project Site would generally have a direct line of sight to the development's two driveways. This includes the Taglyan Complex approximately 100 feet west of the Vine Street driveway and the 6236-6240 Lexington Avenue apartments about 80 feet south of the Lexington Avenue driveway. As shown in **Table 6-7**, the average vehicle use of the garage during daytime hours (average of 4.5 vehicles per hour between 8:00 A.M. and 7:00 P.M.) and nighttime hours (an average of 1.5 vehicles hourly from 7:00 P.M. to 8:00 A.M.) would elevate ambient noise levels by less than 0.1 dBA CNEL, well below the 5 dBA threshold of significance for operational sources of noise.

⁵² Gibson Transportation Consulting, Inc. Transportation Assessment for the 1200 Vine Street Project; November 2, 2022.

⁵³ Gibson Transportation Consulting, Inc. Transportation Assessment for the 1200 Vine Street Project; November 2, 2022.

Parking garage-related noise impacts for other receptors would also be negligible given their more remote locations and/or the lack of a line of sight from the garage. Parking garage noise would include tire friction as vehicles navigate to and from parking spaces, doors slamming, car alarms, and minor engine acceleration. Most of these sources are instantaneous (e.g., car alarm chirp, door slam) while others may last a few seconds. As such, the Project’s parking garage activities would not have a significant impact on the surrounding noise environment.

**Table 6-7
Parking Garage-Related Impacts at Off-Site Sensitive Receptors**

Receptor	Maximum Noise Level (dBA CNEL)	Existing Ambient Noise Level (dBA CNEL)	New Ambient Noise Level (dBA CNEL)	Increase (dBA CNEL)	Significant ?
Taglyan Complex	36.2	66.1	66.1	<0.1	No
Residences, 6236-6240 Lexington Ave.	38.7	55.6	55.6	<0.1	No
Source: DKA Planning, 2022, using FTA Noise Impact Assessment Spreadsheet. Assumes a 50/50 split between ADT for each garage entrance based on peak hour trip generation estimates.					

Outdoor Uses. Noise associated with everyday residential and commercial activities would largely be contained internally within the Project. This includes the commercial retail space fronting Vine Street and various uses supporting the residences (e.g., pool room, co-work space, club lounges, fitness rooms), all integrated within the development itself. However, there are outdoor activities that could generate noise, including human conversation, trash collection, landscape maintenance, and commercial loading. These are discussed below:

- Human conversation. There are three outdoor spaces that could generate noise from passive activities like human conversation and socializing, including:
 - Ground-level outdoor plaza (1,700 square feet) facing Lexington Avenue near Vine Street.
 - Roof deck on the 8th floor (1,100 square feet) at the northwest corner of the development facing Vine Street.
 - Roof deck on the 8th floor (1,200 square feet) at the southeast corner of the development facing Lexington Avenue.

All these areas would be used for passive socializing and recreation. There would be intermittent activities that would produce negligible impacts from human speech, based on the Lombard effect. This phenomenon recognizes that voice noise levels in face-to-face conversations generally increase proportionally to background ambient noise levels, but only up to approximately 67 dBA at a reference distance of one meter. Specifically, vocal intensity increases about 0.38 dB for every 1.0 dB increase in noise levels above 55 dB, meaning people talk slightly above ambient noise levels in order to communicate.⁵⁴

⁵⁴ Acoustical Society of America, Volume 134; Evidence that the Lombard effect is frequency-specific in humans, Stowe and Golob, July 2013.

Each of these outdoor areas would have negligible impacts on the local noise environment. The ground-level plaza is oriented Vine Street and any noise affecting residences along Lexington Avenue would be shielded by the leasing office and lobby of the development to the east. The 8th floor roof deck at the northwest corner of the development would face both Vine Street where the Taglyan Complex would be 100 feet west and the mental health building to the north where there are no windows or openings facing the development. The 8th floor roof deck at the southeast corner of the development would be nearly 74 feet above the street level, where it would be about 54 feet above the apartments across Lexington Avenue.

As such, when combined with the nature of human conversation (Lombard effect), these three outdoor areas would produce intermittent noise from socializing that would not result in significant noise impacts and would not elevate noise levels at nearby sensitive receptors over a 24-hour period by 5 dBA CNEL or more.

- Trash collection. On-site trash and recyclable materials for the residents and merchants would be managed from a waste collection area on the ground floor of the parking garage. Haul trucks would likely access solid waste from Vine Street, where solid waste activities would include use of trash compactors and hydraulics associated with the refuse trucks themselves. Noise levels of approximately 71 dBA L_{eq} and 66 dBA L_{eq} could be generated by collection trucks and trash compactors, respectively, at 50 feet of distance.⁵⁵ Intermittent solid waste management activities would operate during the day. Trash collection activities would not substantially elevate 24-hour noise levels at off-site locations by 5 dBA CNEL or more.
- Landscape maintenance. Noise from gas-powered leaf blowers, lawnmowers, and other landscape equipment can generate substantial bursts of noise during regular maintenance. For example, gas powered leaf blowers and other equipment with two-stroke engines can generate 100 dBA L_{eq} and cause nuisance or potential noise impacts for nearby receptors.⁵⁶ Any intermittent landscape equipment would operate during the day and would represent a negligible impact that would not increase 24-hour noise levels at off-site locations by 5 dBA CNEL or more.⁵⁷
- Commercial loading. On-site loading and unloading activities would be managed in the ground floor of the parking garage which vehicles would access from the Vine Street driveway. This internal drop-off zone is obscured from any off-site sensitive receptors by the development itself. As a result, there would be negligible noise impacts on off-site receptors and impacts would not increase CNEL noise levels at off-site locations. Further, LAMC Section 114.03 would regulate loading and unloading activities between 10:00 P.M. and 7:00 A.M.

Based on an assessment of these on-site sources, the impact of on-site operational noise sources would be considered less than significant.

⁵⁵ RK Engineering Group, Inc. Wal-Mart/Sam's Club reference noise level, 2003.

⁵⁶ Erica Walker et al, Harvard School of Public Health; Characteristics of Lawn and Garden Equipment Sound; 2017

⁵⁷ While AB 1346 (Berman, 2021) bans the sale of new gas-powered leaf blowers by 2024, existing equipment can continue to operate indefinitely.

6.6.2.2 Off-Site Operational Noise Sources

The majority of the Project’s operational noise impacts would be off-site from vehicles traveling to and from the development. The Project could add up to 892 vehicle trips to the local roadway network on a peak weekday at the start of operations in 2027. During the peak P.M. hour, approximately 54 vehicles would generate noise in and out of the residents’ garage via the driveway off Lexington Avenue, with up to 54 vehicles using the garage in the peak A.M. hour.⁵⁸ Vehicles accessing the commercial garage would generate about 41 vehicle trips from the driveway off Vine Street in the peak P.M. hour and 43 trips in the A.M. peak hour. Even if all vehicles accessing the development were to use Vine Street, this would represent about 3.8 percent of traffic volumes on Vine Street, which carries about 2,552 vehicles at Lexington Avenue in the morning peak hour of traffic.⁵⁹

Because it takes a doubling of traffic volumes (i.e., 100 percent) to increase ambient noise levels by 3 dBA L_{eq} , the Project’s traffic would neither increase ambient noise levels 3 dBA or more into “normally unacceptable” or “clearly unacceptable” noise/land use compatibility categories, nor increase ambient noise levels 5 dBA or more. Twenty-four hour CNEL impacts would similarly be minimal, far below criterion for significant operational noise impacts, which begin at 3 dBA. As such, this impact would be considered less than significant.

6.7 Airport Noise

The Project Site is located about 7.2 miles south of the Hollywood Burbank Airport, 8.5 miles northeast of the Santa Monica Airport, and 10.5 miles east of Los Angeles International Airport. Because the Project would not be located within the vicinity of a private airstrip or within two miles of a public airport, the Project would not expose local workers or residents in the area to excessive noise levels. This would be considered a less than significant impact.

6.8 Conclusion

For all the foregoing reasons, the Project would not have a significant impact related to noise and, therefore, would comply with CCR Section 15332(d).

⁵⁸ Gibson Transportation Consulting, Inc. Transportation Assessment for the 1200 Vine Street Project; November 2, 2022.

⁵⁹ Gibson Transportation Consulting, Inc. Transportation Assessment for the 1200 Vine Street Project; November 2, 2022.

7 Discussion of CCR Section 15332(d): Air Quality

Approval of the project would not result in any significant effects relating to traffic, noise, air quality, or water quality.⁶⁰

This section is based on the following item, included as **Appendix E** of this CE:

E Air Quality Technical Modeling, DKA Planning, October 2022

7.1 Regulatory Framework

7.1.1 Federal

7.1.1.1 Clean Air Act

The Federal Clean Air Act (CAA) was first enacted in 1955 and has been amended numerous times in subsequent years, with the most recent amendments in 1990. At the federal level, the United States Environmental Protection Agency (USEPA) is responsible for implementation of some portions of the CAA (e.g., certain mobile source and other requirements). Other portions of the CAA (e.g., stationary source requirements) are implemented by state and local agencies. In California, the CCAA is administered by the California Air Resources Board (CARB) at the state level and by the air quality management districts and air pollution control districts at the regional and local levels.

The 1990 amendments to the CAA identify specific emission reduction goals for areas not meeting the National Ambient Air Quality Standards (NAAQS). These amendments require both a demonstration of reasonable further progress toward attainment and incorporation of additional sanctions for failure to attain or to meet interim milestones. The sections of the CAA which are most applicable to the Project include Title I (Nonattainment Provisions) and Title II (Mobile Source Provisions).

NAAQS have been established for seven major air pollutants: CO (carbon monoxide), NO₂ (nitrogen dioxide), O₃ (ozone), PM_{2.5} (particulate matter, 2.5 microns), PM₁₀ (particulate matter, 10 microns), SO₂ (sulfur dioxide), and Pb (lead).

The CAA requires USEPA to designate areas as attainment, nonattainment, or maintenance (previously nonattainment and currently attainment) for each criteria pollutant based on whether the NAAQS have been achieved. Title I provisions are implemented for the purpose of attaining NAAQS. The federal standards are summarized in **Table 7-1**. USEPA has classified the Los Angeles County portion of the South Coast Air Basin (Basin) as a nonattainment area for O₃, PM_{2.5}, and Pb.

⁶⁰ Each of these topic areas (traffic, noise, air quality, and water quality) is discussed in its own section.

Table 7-1
State and National Ambient Air Quality Standards and Attainment Status for LA County

Pollutant	Averaging Period	California		Federal	
		Standards	Attainment Status	Standards	Attainment Status
Ozone (O ₃)	1-hour	0.09 ppm (180 µg/m ³)	Non-attainment	--	--
	8-hour	0.070 ppm (137 µg/m ³)	N/A ¹	0.070 ppm (137 µg/m ³)	Non-attainment
Respirable Particulate Matter (PM ₁₀)	24-hour	50 µg/m ³	Non-attainment	150 µg/m ³	Maintenance
	Annual Arithmetic Mean	20 µg/m ³	Non-attainment	--	--
Fine Particulate Matter (PM _{2.5})	24-hour	--	--	35 µg/m ³	Non-attainment
	Annual Arithmetic Mean	12 µg/m ³	Non-attainment	12 µg/m ³	Non-attainment
Carbon Monoxide (CO)	1-hour	20 ppm (23 µg /m ³)	Attainment	35 ppm (40 µg /m ³)	Maintenance
	8-hour	9.0 ppm (10 µg /m ³)	Attainment	9 ppm (10 µg /m ³)	Maintenance
Nitrogen Dioxide (NO ₂)	1-hour	0.18 ppm (338 µg/m ³)	Attainment	100 ppb (188 µg/m ³)	Maintenance
	Annual Arithmetic Mean	0.030 ppm (57 µg/m ³)	Attainment	53 ppb (100 µg/m ³)	Maintenance
Sulfur Dioxide (SO ₂)	1-hour	0.25 ppm (655 µg/m ³)	Attainment	75 ppb (196 µg/m ³)	Attainment
	24-hour	0.04 ppm (105 µg/m ³)	Attainment	--	--
Lead (Pb)	30-day average	1.5 µg/m ³	Attainment	--	--
	Calendar Quarter	--	--	0.15 µg/m ³	Non-attainment
Visibility Reducing Particles	8-hour	Extinction of 0.07 per kilometer	N/A	No Federal Standards	
Sulfates (SO ₄)	24-hour	25 µg/m ³	Attainment	No Federal Standards	
Hydrogen Sulfide (H ₂ S)	1-hour	0.03 ppm (42 µg/m ³)	Unclassified	No Federal Standards	
Vinyl Chloride	24-hour	0.01 ppm (26 µg/m ³)	N/A	No Federal Standards	

¹N/A = not available

Source: CARB, Ambient Air Quality Standards, and attainment status, 2021

<https://ww2.arb.ca.gov/resources/documents/maps-state-and-federal-area-designations>

CAA Title II pertains to mobile sources, such as cars, trucks, buses, and planes. Reformulated gasoline and automobile pollution control devices are examples of the mechanisms the USEPA uses to regulate mobile air emission sources. The provisions of Title II have resulted in tailpipe emission standards for vehicles, which have been strengthened in recent years to improve air quality. For example, the standards for NO_x emissions have been lowered substantially and the specification requirements for cleaner burning gasoline are more stringent.

The USEPA regulates emission sources that are under the exclusive authority of the federal government, such as aircraft, ships, and certain types of locomotives. USEPA has jurisdiction over emission sources outside state waters (e.g., beyond the outer continental shelf) and establishes various emission standards, including those for vehicles sold in states other than California. Automobiles sold in California must meet stricter emission standards established by CARB. USEPA adopted multiple tiers of emission standards to reduce emissions from non-road diesel engines (e.g., diesel-powered construction equipment) by integrating engine and fuel controls as a system to gain the greatest emission reductions.

The first federal standards (Tier 1) for new non-road (or off-road) diesel engines were adopted in 1994 for engines over 50 horsepower, to be phased-in from 1996 to 2000. On August 27, 1998, USEPA introduced Tier 1 standards for equipment under 37 kW (50 horsepower) and increasingly more stringent Tier 2 and Tier 3 standards for all equipment with phase-in schedules from 2000 to 2008. The Tier 1 through 3 standards were met through advanced engine design, with no or only limited use of exhaust gas after-treatment (oxidation catalysts). Tier 3 standards for NO_x and hydrocarbon are similar in stringency to the 2004 standards for highway engines. However, Tier 3 standards for particulate matter were never adopted.

On May 11, 2004, USEPA signed the final rule introducing Tier 4 emission standards, which were phased-in between 2008 and 2015. The Tier 4 standards require that emissions of particulate matter and NO_x be further reduced by about 90 percent. Such emission reductions are achieved through the use of control technologies—including advanced exhaust gas after-treatment.

7.1.2 State

7.1.2.1 California Clean Air Act

In addition to being subject to the requirements of CAA, air quality in California is also governed by more stringent regulations under the California Clean Air Act (CCAA). In California, CCAA is administered by CARB at the state level and by the air quality management districts and air pollution control districts at the regional and local levels. CARB, which became part of the California Environmental Protection Agency in 1991, is responsible for meeting the state requirements of the CAA, administering the CCAA, and establishing the California Ambient Air Quality Standards (CAAQS). The CCAA, as amended in 1992, requires all air districts in the State to endeavor to achieve and maintain the CAAQS. CAAQS are generally more stringent than the corresponding federal standards and incorporate additional standards for sulfates, hydrogen sulfide, vinyl chloride, and visibility-reducing particles.

CARB regulates mobile air pollution sources, such as motor vehicles. CARB is responsible for setting emission standards for vehicles sold in California and for other emission sources, such as consumer products and certain off-road equipment. CARB established passenger vehicle fuel

specifications in March 1996. CARB oversees the functions of local air pollution control districts and air quality management districts, which, in turn, administer air quality activities at the regional and county levels. The State standards are summarized in **Table 7-1**.

The CCAA requires CARB to designate areas within California as either attainment or nonattainment for each criteria pollutant based on whether the CAAQS thresholds have been achieved. Under the CCAA, areas are designated as nonattainment for a pollutant if air quality data shows that a state standard for the pollutant was violated at least once during the previous three calendar years. Exceedances that are affected by highly irregular or infrequent events are not considered violations of a state standard and are not used as a basis for designating areas as nonattainment. Under the CCAA, the non-desert Los Angeles County portion of the Basin is designated as a nonattainment area for O₃, PM₁₀, and PM_{2.5}.

7.1.2.2 Toxic Air Contaminant Identification and Control Act

The public's exposure to toxic air contaminants (TACs) is a significant public health issue in California. CARB's statewide comprehensive air toxics program was established in the early 1980s. The Toxic Air Contaminant Identification and Control Act created California's program to reduce exposure to air toxics. Under the Toxic Air Contaminant Identification and Control Act, CARB is required to use certain criteria in the prioritization for the identification and control of air toxics. In selecting substances for review, CARB must consider criteria relating to "the risk of harm to public health, amount or potential amount of emissions, manner of, and exposure to, usage of the substance in California, persistence in the atmosphere, and ambient concentrations in the community" [Health and Safety Code Section 39666(f)].

The Toxic Air Contaminant Identification and Control Act also requires CARB to use available information gathered from the Air Toxics "Hot Spots" Information and Assessment Act program to include in the prioritization of compounds. CARB identified particulate emissions from diesel-fueled engines (diesel PM) TACs in August 1998. Following the identification process, CARB was required by law to determine if there is a need for further control, which led to the risk management phase of the program.

For the risk management phase, CARB formed the Diesel Advisory Committee to assist in the development of a risk management guidance document and a risk reduction plan. With the assistance of the Diesel Advisory Committee and its subcommittees, CARB developed the Risk Reduction Plan to Reduce Particulate Matter Emissions from Diesel-Fueled Engines and Vehicles and the Risk Management Guidance for the Permitting of New Stationary Diesel-Fueled Engines. The Board approved these documents on September 28, 2000, paving the way for the next step in the regulatory process: the control measure phase. During the control measure phase, specific Statewide regulations designed to further reduce diesel particulate matter (PM) emissions from diesel-fueled engines and vehicles have and continue to be evaluated and developed. The goal of each regulation is to make diesel engines as clean as possible by establishing state-of-the-art technology requirements or emission standards to reduce diesel PM emissions. Breathing Hydrogen Sulfide (H₂S) at levels above the state standard could result in exposure to a disagreeable rotten eggs odor. The State does not regulate other odors.

7.1.2.3 California Air Toxics Program

The California Air Toxics Program was established in 1983, when the California Legislature adopted Assembly Bill (AB) 1807 to establish a two-step process of risk identification and risk management to address potential health effects from exposure to toxic substances in the air.⁶¹ In the risk identification step, CARB and the Office of Environmental Health Hazard Assessment (OEHHA) determine if a substance should be formally identified, or “listed,” as a TAC in California. Since inception of the program, a number of such substances have been listed, including benzene, chloroform, formaldehyde, and particulate emissions from diesel-fueled engines, among others.⁶² In 1993, the California Legislature amended the program to identify the 189 federal hazardous air pollutants as TACs.

In the risk management step, CARB reviews emission sources of an identified TAC to determine whether regulatory action is needed to reduce risk. Based on results of that review, CARB has promulgated a number of airborne toxic control measures (ATCMs), both for mobile and stationary sources. In 2004, CARB adopted an ATCM to limit heavy-duty diesel motor vehicle idling in order to reduce public exposure to diesel PM and other TACs. The measure applies to diesel-fueled commercial vehicles with gross vehicle weight ratings greater than 10,000 pounds that are licensed to operate on highways, regardless of where they are registered. This measure does not allow diesel-fueled commercial vehicles to idle for more than five minutes at any given time.

In addition to limiting exhaust from idling trucks, CARB adopted regulations on July 26, 2007 for off-road diesel construction equipment such as bulldozers, loaders, backhoes, and forklifts, as well as many other self-propelled off-road diesel vehicles to reduce emissions by installation of diesel particulate filters and encouraging the replacement of older, dirtier engines with newer emission-controlled models. Implementation is staggered based on fleet size, with the largest operators having begun compliance in 2014.⁶³

7.1.2.4 Assembly Bill 2588 Air Toxics “Hot Spots” Program

The AB 1807 program is supplemented by the AB 2588 Air Toxics “Hot Spots” program, which was established by the California Legislature in 1987. Under this program, facilities are required to report their air toxics emissions, assess health risks, and notify nearby residents and workers of significant risks if present. In 1992, the AB 2588 program was amended by Senate Bill (SB) 1731 to require facilities that pose a significant health risk to the community to reduce their risk through implementation of a risk management plan.

7.1.2.5 Air Quality and Land Use Handbook: A Community Health Perspective

CARB published the *Air Quality and Land Use Handbook* (CARB Handbook) on April 28, 2005 to serve as a general guide for considering health effects associated with siting sensitive receptors proximate to sources of TAC emissions. The recommendations provided therein are voluntary and do not constitute a requirement or mandate for either land use agencies or local air districts.

⁶¹ CARB, California Air Toxics Program, <https://ww2.arb.ca.gov/our-work/topics/airborne-toxics>

⁶² CARB, Toxic Air Contaminant Identification List, <https://ww2.arb.ca.gov/resources/documents/carb-identified-toxic-air-contaminants>

⁶³ CARB, In-Use Off-Road Diesel-Fueled Fleets Regulation, <https://ww2.arb.ca.gov/our-work/programs/use-road-diesel-fueled-fleets-regulation>

The goal of the guidance document is to protect sensitive receptors, such as children, the elderly, acutely ill, and chronically ill persons, from exposure to TAC emissions. Some examples of CARB's siting recommendations include the following: (1) avoid siting sensitive receptors within 500 feet of a freeway, urban road with 100,000 vehicles per day, or rural roads with 50,000 vehicles per day; (2) avoid siting sensitive receptors within 1,000 feet of a distribution center (that accommodates more than 100 trucks per day, more than 40 trucks with operating transport refrigeration units per day, or where transport refrigeration unit operations exceed 300 hours per week); and (3) avoid siting sensitive receptors within 300 feet of any dry cleaning operation using perchloroethylene and within 500 feet of operations with two or more machines.

7.1.2.6 California Code of Regulations

The California Code of Regulations (CCR) is the official compilation and publication of regulations adopted, amended or repealed by the state agencies pursuant to the Administrative Procedure Act. The CCR includes regulations that pertain to air quality emissions. Specifically, Section 2485 in CCR Title 13 states that the idling of all diesel-fueled commercial vehicles (weighing over 10,000 pounds) used during construction shall be limited to five minutes at any location. In addition, Section 93115 in CCR Title 17 states that operation of any stationary, diesel-fueled, compression-ignition engines shall meet specified fuel and fuel additive requirements and emission standards.

7.1.3 Regional

7.1.3.1 South Coast Air Quality Management District

The SCAQMD was created in 1977 to coordinate air quality planning efforts throughout Southern California. SCAQMD is the agency principally responsible for comprehensive air pollution control in the region. Specifically, SCAQMD is responsible for monitoring air quality, as well as planning, implementing, and enforcing programs designed to attain and maintain the CAAQS and NAAQS in the district. SCAQMD has jurisdiction over an area of 10,743 square miles consisting of Orange County; the non-desert portions of Los Angeles, Riverside, and San Bernardino counties; and the Riverside County portion of the Salton Sea Air Basin and Mojave Desert Air Basin. The Basin portion of SCAQMD's jurisdiction covers an area of 6,745 square miles. The Basin includes all of Orange County and the non-desert portions of Los Angeles (including the Project Area), Riverside, and San Bernardino counties. The Basin is bounded by the Pacific Ocean to the west; the San Gabriel, San Bernardino and San Jacinto Mountains to the north and east; and the San Diego County line to the south.

Programs that were developed by SCAQMD to attain and maintain the CAAQS and NAAQS include air quality rules and regulations that regulate stationary sources, area sources, point sources, and certain mobile source emissions. SCAQMD is also responsible for establishing stationary source permitting requirements and for ensuring that new, modified, or relocated stationary sources do not create net emission increases. All projects in the SCAQMD jurisdiction are subject to SCAQMD rules and regulations, including, but not limited to the following:

- Rule 401 Visible Emissions – This rule prohibits an air discharge that results in a plume that is as dark or darker than what is designated as No. 1 Ringelmann Chart by the United States Bureau of Mines for an aggregate of three minutes in any one hour.

- Rule 402 Nuisance – This rule prohibits the discharge of “such quantities of air contaminants or other material which cause injury, detriment, nuisance, or annoyance to any considerable number of people or the public, or which endanger the comfort, repose, health or safety of any such persons or the public, or which cause, or have a natural tendency to cause, injury or damage to business or property.”
- Rule 403 Fugitive Dust – This rule requires that future projects reduce the amount of particulate matter entrained in the ambient air as a result of fugitive dust sources by requiring actions to prevent, reduce, or mitigate fugitive dust emissions from any active operation, open storage pile, or disturbed surface area.

7.1.3.2 Air Quality Management Plan

SCAQMD adopted the 2022 Air Quality Management Plan (AQMP) on December 2, 2022, updating the region’s air quality attainment plan to address the “extreme” ozone non-attainment status for the Basin and the severe ozone non-attainment for the Coachella Valley Basin by laying a path for attainment by 2037. This includes reducing NOx emissions by 67 percent more than required by adopted rules and regulations in 2037. The AQMP calls on strengthening many stationary source controls and addressing new sources like wildfires, but still concludes that the region will not meet air quality standards without a significant shift to zero emission technologies and significant federal action. The 2022 AQMP relies on the growth assumptions in SCAG’s 2020-2045 RTP/SCS.

7.1.3.3 Multiple Air Toxics Exposure Study V

To date, the most comprehensive study on air toxics in the Basin is the Multiple Air Toxics Exposure Study V, released in August 2021.⁶⁴ The report included refinements in aircraft and recreational boating emissions and diesel conversion factors. The report finds a Basin average cancer risk of 455 in a million (population-weighted, multi-pathway), which represents a decrease of 54 percent compared to the number in MATES IV (2012) (page ES-13). The monitoring program measured more than 30 air pollutants, including both gases and particulates. The monitoring study was accompanied by a computer modeling study in which the SCAQMD estimated the risk of cancer from breathing toxic air pollution throughout the region based on emissions and weather data. About 88 percent of the risk is attributed to emissions associated with mobile sources, with the remainder attributed to toxics emitted from stationary sources, which include large industrial operations, such as refineries and metal processing facilities, as well as smaller businesses such as gas stations and chrome plating facilities (page ES-12). The results indicate that diesel PM is the largest contributor to air toxics risk, accounting on average for about 50 percent of the total risk (Figure ES-2).

7.1.3.4 Southern California Association of Governments (SCAG)

SCAG is the regional planning agency for Los Angeles, Orange, Ventura, Riverside, San Bernardino, and Imperial Counties, and addresses regional issues relating to transportation, the economy, community development and the environment. SCAG coordinates with various air

⁶⁴ South Coast Air Quality Management District, MATES-V Study. <https://www.aqmd.gov/home/air-quality/air-quality-studies/health-studies/mates-v>

quality and transportation stakeholders in Southern California to ensure compliance with the federal and state air quality requirements, including the Transportation Conformity Rule and other applicable federal, state, and air district laws and regulations. As the federally designated Metropolitan Planning Organization (MPO) for the six-county Southern California region, SCAG is required by law to ensure that transportation activities “conform” to, and are supportive of, the goals of regional and state air quality plans to attain the NAAQS. In addition, SCAG is a co-producer, with the SCAQMD, of the transportation strategy and transportation control measure sections of the AQMP for the Air Basin.

SCAG adopted the 2016–2040 Regional Transportation Plan/Sustainable Communities Strategy (RTP/SCS) on April 7, 2016.^{65,66} The 2016–2040 RTP/SCS reaffirms the land use policies that were incorporated into SCAG’s prior 2012–2035 RTP/SCS. These foundational policies, which guided the development of the plan’s land use strategies, include the following:

- Identify regional strategic areas for infill and investment;
- Structure the plan on a three-tiered system of centers development;
- Develop “Complete Communities”;
- Develop nodes on a corridor;
- Plan for additional housing and jobs near transit;
- Plan for changing demand in types of housing;
- Continue to protect stable, existing single-family areas;
- Ensure adequate access to open space and preservation of habitat; and
- Incorporate local input and feedback on future growth.

The 2016–2040 RTP/SCS recognizes that transportation investments and future land use patterns are inextricably linked, and continued recognition of this close relationship will help the region make choices that sustain existing resources and expand efficiency, mobility, and accessibility for people across the region. In particular, the 2016–2040 RTP/SCS draws a closer connection between where people live and work, and it offers a blueprint for how Southern California can grow more sustainably. The 2016–2040 RTP/SCS also includes strategies focused on compact infill development and economic growth by building the infrastructure the region needs to promote the smooth flow of goods and easier access to jobs, services, educational facilities, healthcare and more.

On September 3, 2020, SCAG’s Regional Council adopted the 2020-2045 RTP/SCS. The 2020-2045 RTP/SCS was determined to conform to the federally-mandated state implementation plan (SIP), for the attainment and maintenance of NAAQS standards. On October 30, 2020, CARB also accepted SCAG’s determination that the SCS met the applicable state greenhouse gas

⁶⁵ SCAG, Final 2016–2040 RTP/SCS.

⁶⁶ CARB, Executive Order G-16-066, SCAG 2016 SCS ARB Acceptance of GHG Quantification Determination, June 2016.

emissions targets. The 2020-2045 RTP/SCS will be incorporated into the forthcoming 2022 AQMP.

The RTP/SCS update addressed the continuing transportation and air quality challenges of adding 3.7 million additional residents, 1.6 additional households, and 1.6 million additional jobs between 2016 and 2045. The Plan calls for \$639 billion in transportation investments and reducing VMT by 19 percent per capita from 2005 to 2035. The updated plan accommodates 21.3 percent regional growth in population from 2016 (3,933,800) to 2045 (4,771,300) and a 15.6 percent growth in jobs from 2016 (1,848,300) to 2045 (2,135,900). The regional plan projects several benefits:

- Decreasing drive-along work commutes by three percent
- Reducing per capita VMT by five percent and vehicle hours traveled per capita by nine percent
- Increasing transit commuting by two percent
- Reducing travel delay per capita by 26 percent
- Creating 264,500 new jobs annually
- Reducing greenfield development by 29 percent by focusing on smart growth
- Locating six more percent household growth in High Quality Transit Areas (HQTAs), which concentrate roadway repair investments, leverage transit and active transportation investments, reduce regional life cycle infrastructure costs, improve accessibility, create local jobs, and have the potential to improve public health and housing affordability.
- Locating 15 percent more jobs in HQTAs
- Reducing PM_{2.5} emissions by 4.1 percent
- Reducing GHG emissions by 19 percent by 2035

7.1.3 Local

7.1.3.1 City of Los Angeles General Plan Air Quality Element

The Air Quality Element of the City's General Plan was adopted on November 24, 1992, and sets forth the goals, objectives, and policies, which guide the City in the implementation of its air quality improvement programs and strategies. The Air Quality Element acknowledges the interrelationships among transportation and land use planning in meeting the City's mobility and air quality goals. The Air Quality Element includes six key goals:

Goal 1: Good air quality in an environment of continued population growth and healthy economic structure.

Goal 2: Less reliance on single-occupant vehicles with fewer commute and non-work trips.

Goal 3: Efficient management of transportation facilities and system infrastructure using cost-effective system management and innovative demand management techniques.

Goal 4: Minimize impacts of existing land use patterns and future land use development on air quality by addressing the relationship between land use, transportation, and air quality.

Goal 5: Energy efficiency through land use and transportation planning, the use of renewable resources and less-polluting fuels and the implementation of conservation measures including passive measures such as site orientation and tree planting.

Goal 6: Citizen awareness of the linkages between personal behavior and air pollution and participation in efforts to reduce air pollution.

7.1.3.2 Clean Up Green Up Ordinance

The City of Los Angeles adopted a Clean Up Green Up Ordinance (Ordinance Number 184,245) on April 13, 2016, which among other provisions, includes provisions related to ventilation system filter efficiency in mechanically ventilated buildings. This ordinance added Sections 95.314.3 and 99.04.504.6 to the Los Angeles Municipal Code (LAMC) and amended Section 99.05.504.5.3 to implement building standards and requirements to address cumulative health impacts resulting from incompatible land use patterns.

7.1.3.3 California Environmental Quality Act

In accordance with CEQA requirements, the City assesses the air quality impacts of new development projects, requires mitigation of potentially significant air quality impacts by conditioning discretionary permits, and monitors and enforces implementation of such mitigation. The City uses the SCAQMD's *CEQA Air Quality Handbook* and SCAQMD's supplemental online guidance/information for the environmental review of plans and development proposals within its jurisdiction.

7.1.3.4 Land Use Compatibility

In November 2012, the Los Angeles City Planning Commission (CPC) issued an advisory notice (Zoning Information 2427) regarding the siting of sensitive land uses within 1,000 feet of freeways. The CPC deemed 1,000 feet to be a conservative distance to evaluate projects that house populations considered to be more at-risk from the negative effects of air pollution caused by freeway proximity. The CPC advised that applicants of projects requiring discretionary approval, located within 1,000 feet of a freeway and contemplating residential units and other sensitive uses (e.g., hospitals, schools, retirement homes) perform a Health Risk Assessment (HRA).

The Project Site is 3,800 feet west of the southbound mainline of the Hollywood Freeway (US-101).

The City of Los Angeles adopted a Clean Up Green Up Ordinance (Ordinance Number 184,245) on April 13, 2016, which among other provisions, includes provisions related to ventilation system filter efficiency in mechanically ventilated buildings located within specified distances from a freeway. This ordinance added Sections 95.314.3 and 99.04.504.6 to the Los Angeles Municipal

Code (LAMC) and amended Section 99.05.504.5.3 to implement building standards and requirements to address cumulative health impacts resulting from incompatible land use patterns.

On April 12, 2018, the City updated its guidance on siting land uses near freeways, resulting in an updated Advisory Notice effective September 17, 2018 requiring all proposed projects within 1,000 feet of a freeway adhere to the Citywide Design Guidelines, including those that address freeway proximity. It also recommended that projects consider avoiding location of sensitive uses like schools, day care facilities, and senior care centers in such projects, locate open space areas as far from the freeway as possible when the size of the site permits, locate non-habitable uses (e.g., parking structures) nearest the freeway, and screen project sites with substantial vegetation and/or a wall barrier. The Advisory Notice also informs project applicants of the regulatory requirements of the Clean Up Green Up Ordinance. Requirements for preparing HRAs were removed.

7.2 Existing Conditions

7.2.1 Pollutants and Effects

7.2.1.1 State and Federal Criteria Pollutants

Air quality is defined by ambient air concentrations of seven specific pollutants identified by the USEPA to be of concern with respect to health and welfare of the general public. These specific pollutants, known as “criteria air pollutants,” are defined as pollutants for which the federal and State governments have established ambient air quality standards, or criteria, for outdoor concentrations to protect public health. Criteria air pollutants include carbon monoxide (CO), ground-level ozone (O₃), nitrogen oxides (NO_x), sulfur oxides (SO_x), particulate matter ten microns or less in diameter (PM₁₀), particulate matter 2.5 microns or less in diameter (PM_{2.5}), and lead (Pb). The following descriptions of each criteria air pollutant and their health effects are based on information provided by the SCAQMD.⁶⁷

Carbon Monoxide (CO). CO is primarily emitted from combustion processes and motor vehicles due to incomplete combustion of fuel. Elevated concentrations of CO weaken the heart’s contractions and lower the amount of oxygen carried by the blood. It is especially dangerous for people with chronic heart disease. Inhalation of CO can cause nausea, dizziness, and headaches at moderate concentrations and can be fatal at high concentrations.

Ozone (O₃). O₃ is a gas that is formed when volatile organic compounds (VOCs) and nitrogen oxides (NO_x)—both byproducts of internal combustion engine exhaust—undergo slow photochemical reactions in the presence of sunlight. O₃ concentrations are generally highest during the summer months when direct sunlight, light wind, and warm temperature conditions are favorable. An elevated level of O₃ irritates the lungs and breathing passages, causing coughing and pain in the chest and throat, thereby increasing susceptibility to respiratory infections and reducing the ability to exercise. Effects are more severe in people with asthma and other

⁶⁷ SCAQMD, Final Program Environmental Impact Report for the 2016 AQMP, <https://www.aqmd.gov/home/air-quality/clean-air-plans/air-quality-mgt-plan/final-2016-aqmp>.

respiratory ailments. Long-term exposure may lead to scarring of lung tissue and may lower lung efficiency.

Nitrogen Dioxide (NO₂). NO₂ is a byproduct of fuel combustion and major sources include power plants, large industrial facilities, and motor vehicles. The principal form of nitrogen oxide produced by combustion is nitric oxide (NO), which reacts quickly to form NO₂, creating the mixture of NO and NO₂ commonly called NO_x. NO₂ absorbs blue light and results in a brownish-red cast to the atmosphere and reduced visibility. NO₂ also contributes to the formation of PM₁₀. Nitrogen oxides irritate the nose and throat, and increase one's susceptibility to respiratory infections, especially in people with asthma. The principal concern of NO_x is as a precursor to the formation of ozone.

Sulfur Dioxide (SO₂). Sulfur oxides (SO_x) are compounds of sulfur and oxygen molecules. SO₂ is the pre-dominant form found in the lower atmosphere and is a product of burning sulfur or burning materials that contain sulfur. Major sources of SO₂ include power plants, large industrial facilities, diesel vehicles, and oil-burning residential heaters. Emissions of sulfur dioxide aggravate lung diseases, especially bronchitis. It also constricts the breathing passages, especially in asthmatics and people involved in moderate to heavy exercise. SO₂ potentially causes wheezing, shortness of breath, and coughing. High levels of particulates appear to worsen the effect of sulfur dioxide, and long-term exposures to both pollutants leads to higher rates of respiratory illness.

Particulate Matter (PM₁₀ and PM_{2.5}). The human body naturally prevents the entry of larger particles into the body. However, small particles, with an aerodynamic diameter equal to or less than 10 microns (PM₁₀), and even smaller particles with an aerodynamic diameter equal to or less than 2.5 microns (PM_{2.5}), can enter the body and become trapped in the nose, throat, and upper respiratory tract. These small particulates can potentially aggravate existing heart and lung diseases, change the body's defenses against inhaled materials, and damage lung tissue. The elderly, children, and those with chronic lung or heart disease are most sensitive to PM₁₀ and PM_{2.5}. Lung impairment can persist for two to three weeks after exposure to high levels of particulate matter. Some types of particulates can become toxic after inhalation due to the presence of certain chemicals and their reaction with internal body fluids.

Lead (Pb). Lead is emitted from industrial facilities and from the sanding or removal of old lead-based paint. Smelting or processing the metal is the primary source of lead emissions, which is primarily a regional pollutant. Lead affects the brain and other parts of the body's nervous system. Exposure to lead in very young children impairs the development of the nervous system, kidneys, and blood forming processes in the body.

7.2.1.2 State-only Criteria Pollutants

Visibility-Reducing Particles. Deterioration of visibility is one of the most obvious manifestations of air pollution and plays a major role in the public's perception of air quality. Visibility reduction from air pollution is often due to the presence of sulfur and NO_x, as well as PM.

Sulfates (SO₄²⁻). Sulfates are the fully oxidized ionic form of sulfur. Sulfates occur in combination with metal and/or hydrogen ions. In California, emissions of sulfur compounds occur primarily from the combustion of petroleum-derived fuels (e.g., gasoline and diesel fuel) that contain sulfur. This sulfur is oxidized during the combustion process and subsequently converted to sulfate

compounds in the atmosphere. Effects of sulfate exposure at levels above the standard include a decrease in ventilatory function, aggravation of asthmatic symptoms, and an increased risk of cardio-pulmonary disease. Sulfates are particularly effective in degrading visibility, and, due to fact that they are usually acidic, can harm ecosystems and damage materials and property.

Hydrogen Sulfide (H₂S). H₂S is a colorless gas with the odor of rotten eggs. It is formed during bacterial decomposition of sulfur-containing organic substances. Also, it can be present in sewer gas and some natural gas and can be emitted as the result of geothermal energy exploitation. Breathing H₂S at levels above the state standard could result in exposure to a very disagreeable odor.

Vinyl Chloride. Vinyl chloride is a colorless, flammable gas at ambient temperature and pressure. It is also highly toxic and is classified as a known carcinogen by the American Conference of Governmental Industrial Hygienists and the International Agency for Research on Cancer. At room temperature, vinyl chloride is a gas with a sickly-sweet odor that is easily condensed. However, it is stored at cooler temperatures as a liquid. Due to the hazardous nature of vinyl chloride to human health, there are no end products that use vinyl chloride in its monomer form. Vinyl chloride is a chemical intermediate, not a final product. It is an important industrial chemical chiefly used to produce polyvinyl chloride (PVC). The process involves vinyl chloride liquid fed to polymerization reactors where it is converted from a monomer to a polymer PVC. The final product of the polymerization process is PVC in either a flake or pellet form. Billions of pounds of PVC are sold on the global market each year. From its flake or pellet form, PVC is sold to companies that heat and mold the PVC into end products such as PVC pipe and bottles. Vinyl chloride emissions are historically associated primarily with landfills.

7.2.2 Toxic Air Contaminants

TACs refer to a diverse group of “non-criteria” air pollutants that can affect human health but have not had ambient air quality standards established for them. This is not because they are fundamentally different from the pollutants discussed above but because their effects tend to be local rather than regional. TACs are classified as carcinogenic and noncarcinogenic, where carcinogenic TACs can cause cancer and noncarcinogenic TAC can cause acute and chronic impacts to different target organ systems (e.g., eyes, respiratory, reproductive, developmental, nervous, and cardiovascular). CARB and OEHHA determine if a substance should be formally identified, or “listed,” as a TAC in California. A complete list of these substances is maintained on CARB’s website.⁶⁸

Diesel particulate matter (DPM), which is emitted in the exhaust from diesel engines, was listed by the state as a TAC in 1998. DPM has historically been used as a surrogate measure of exposure for all diesel exhaust emissions. DPM consists of fine particles (fine particles have a diameter less than 2.5 micrometer (µm)), including a subgroup of ultrafine particles (ultrafine particles have a diameter less than 0.1 µm). Collectively, these particles have a large surface area which makes them an excellent medium for absorbing organics. The visible emissions in diesel exhaust include carbon particles or “soot.” Diesel exhaust also contains a variety of harmful gases and cancer-causing substances.

⁶⁸ CARB, Toxic Air Contaminant Identification List, www.arb.ca.gov/toxics/id/taclist.htm.

Exposure to DPM may be a health hazard, particularly to children whose lungs are still developing and the elderly who may have other serious health problems. DPM levels and resultant potential health effects may be higher in close proximity to heavily traveled roadways with substantial truck traffic or near industrial facilities. According to CARB, DPM exposure may lead to the following adverse health effects: (1) aggravated asthma; (2) chronic bronchitis; (3) increased respiratory and cardiovascular hospitalizations; (4) decreased lung function in children; (5) lung cancer; and (6) premature deaths for people with heart or lung disease.^{69,70}

7.2.4 Project Site

The Project Site is located within the South Coast Air Basin (the Basin); named so because of its geographical formation is that of a basin, with the surrounding mountains trapping the air and its pollutants in the valleys or basins below. The 6,745-square-mile Basin includes all of Orange County and the non-desert portions of Los Angeles, Riverside, and San Bernardino Counties. It is bounded by the Pacific Ocean to the west; the San Gabriel, San Bernardino and San Jacinto Mountains to the north and east; and the San Diego County line to the south.

Ambient pollution concentrations recorded in Los Angeles County portion of the Basin are among the highest in the four counties comprising the Basin. USEPA has classified Los Angeles County as nonattainment areas for O₃, PM_{2.5}, and lead. This classification denotes that the Basin does not meet the NAAQS for these pollutants. In addition, under the CCAA, the Los Angeles County portion of the Basin is designated as a nonattainment area for O₃, PM₁₀, and PM_{2.5}. The air quality within the Basin is primarily influenced by a wide range of emissions sources, such as dense population centers, heavy vehicular traffic, industry, and meteorology.

Air pollutant emissions are generated in the local vicinity by stationary and area-wide sources, such as commercial activity, space and water heating, landscaping maintenance, consumer products, and mobile sources primarily consisting of automobile traffic.

7.2.4.1 Air Pollution Climatology⁷¹

The topography and climate of Southern California combine to make the Basin an area of high air pollution potential. During the summer months, a warm air mass frequently descends over the cool, moist marine layer produced by the interaction between the ocean's surface and the lowest layer of the atmosphere. The warm upper layer forms a cap over the cooler surface layer which inhibits the pollutants from dispersing upward. Light winds during the summer further limit ventilation. Additionally, abundant sunlight triggers photochemical reactions which produce O₃ and the majority of particulate matter.

7.2.4.2 Air Monitoring Data

The SCAQMD monitors air quality conditions at 38 source receptor areas (SRA) throughout the Basin. The Project Site is located in SCAQMD's Central Los Angeles receptor area. Historical data from the area was used to characterize existing conditions in the vicinity of the Project area.

⁶⁹ CARB, Overview: Diesel Exhaust and Health, www.arb.ca.gov/research/diesel/diesel-health.htm.

⁷⁰ CARB, Fact Sheet: Diesel Particulate Matter Health Risk Assessment Study for the West Oakland Community: Preliminary Summary of Results, March 2008.

⁷¹ AQMD, Final Program Environmental Impact Report for the 2012 AQMP, December 7, 2012.

Table 7-2 shows pollutant levels, State and federal standards, and the number of exceedances recorded in the area from 2018 through 2020. The one-hour State standard for O₃ was exceeded 16 times during this three-year period, including fourteen times in 2020. The federal standard was exceeded 28 times in that same period. In addition, the daily State standard for PM₁₀ was exceeded 58 times, with a substantial reduction in exceedances in 2019. The daily federal standard for PM_{2.5} was exceeded six times. CO and NO₂ levels did not exceed the CAAQS from 2018 to 2020 for 1-hour (and 8-hour for CO).

**Table 7-2
Ambient Air Quality Data**

Pollutants and State and Federal Standards	Maximum Concentrations and Frequencies of Exceedance Standards		
	2018	2019	2020
Ozone (O₃)			
Maximum 1-hour Concentration (ppm)	0.098	0.080	0.185
Days > 0.09 ppm (State 1-hour standard)	2	0	14
Days > 0.070 ppm (Federal 8-hour standard)	4	2	22
Carbon Monoxide (CO₂)			
Maximum 1-hour Concentration (ppm)	2.0	2.0	1.9
Days > 20 ppm (State 1-hour standard)	0	0	0
Maximum 8-hour Concentration (ppm)	1.7	1.6	1.5
Days > 9.0 ppm (State 8-hour standard)	0	0	0
Nitrogen Dioxide (NO₂)			
Maximum 1-hour Concentration (ppm)	0.0701	0.0697	0.0618
Days > 0.18 ppm (State 1-hour standard)	0	0	0
PM₁₀			
Maximum 24-hour Concentration (µg/m ³)	81	62	77
Days > 50 µg/m ³ (State 24-hour standard)	31	3	24
PM_{2.5}			
Maximum 24-hour Concentration (µg/m ³)	49.2	43.5	47.3
Days > 35 µg/m ³ (Federal 24-hour standard)	3	1	2
Sulfur Dioxide (SO₂)			
Maximum 24-hour Concentration (ppb)	17.9	10.0	3.8
Days > 0.04 ppm (State 24-hour standard)	0	0	0
ppm = parts by volume per million of air. µg/m ³ = micrograms per cubic meter. N/A = not available at this monitoring station. Source: SCAQMD annual monitoring data at Central LA subregion (http://www.aqmd.gov/home/air-quality/air-quality-data-studies/historical-data-by-year) accessed September 28, 2022.			

7.2.4.3 Existing Health Risk in the Surrounding Area

Based on the MATES-V model, the calculated cancer risk in the Project area (zip code 90038) is approximately 541 in a million.⁷² The cancer risk in this area is predominately related to nearby

⁷² South Coast Air Quality Management District, Multiple Air Toxics Exposure Study in the South Coast Air Basin (MATES-V), MATES V Interactive Carcinogenicity Map, 2021,

sources of diesel particulate matter (e.g., diesel trucks and traffic on the Hollywood Freeway 3,800 feet to the south). In general, the risk at the Project Site is higher than 78 percent of the population across the South Coast Air Basin.

The Office of Environmental Health Hazard Assessment, on behalf of the California Environmental Protection Agency (CalEPA), provides a screening tool called CalEnviroScreen that can be used to help identify California communities disproportionately burdened by multiple sources of pollution. According to CalEnviroScreen, the Project Site (Census tract 6037190801) is located in the 95th percentile, which means the Project Site has an overall environmental pollution burden higher than at least 95 percent of other communities within California.⁷³

7.2.4.4 Sensitive Receptors

Some land uses are considered more sensitive to changes in air quality than others, depending on the population groups and the activities involved. The California Air Resources Board (CARB) has identified the following groups who are most likely to be affected by air pollution: children less than 14 years of age, the elderly over 65 years of age, athletes, and people with cardiovascular and chronic respiratory diseases. According to the SCAQMD, sensitive receptors include residences, schools, playgrounds, childcare centers, athletic facilities, long-term health care facilities, rehabilitation centers, convalescent centers, and retirement homes.

The Project Site is located on the Vine Street commercial corridor in the Hollywood neighborhood. Sensitive receptors within 0.25 miles of the Project Site include, but are not limited to, the following representative sampling:

- Mental Health Center, 1224 Vine Street, directly north of the Project Site.
- Residences, 6232-6238 La Mirada Avenue, five feet east of the Project Site.
- Residences, 6231-6239 Lexington Avenue, five feet east of the Project Site.
- Residences, 6236-6240 Lexington Avenue, 80 feet south of the Project Site.
- Taglyan Complex special event center, 1201 Vine Street, 90 feet west of the Project Site.
- Early Head Start School, 1147 Vine Street, 160 feet southwest of the Project Site.
- Hotel (residential rentals), 6326 Lexington Avenue, 230 feet west of the Project Site.
- Hampton Inn & Suites Hotel, 1133 Vine Street; 300 feet southwest of the Project Site.
- Episcopal School of Los Angeles, 6235 Santa Monica Boulevard, 585 feet southwest of the Project Site.

https://experience.arcgis.com/experience/79d3b6304912414bb21ebdde80100b23/page/home/?data_id=dataSource_105-a5ba9580e3aa43508a793fac819a5a4d%3A26&views=view_39%2Cview_1, accessed October 5, 2022.

⁷³ Office of Environmental Health Hazard Assessment, <https://oehha.ca.gov/calenviroscreen/report/calenviroscreen-40>, accessed October 5, 2022.

- Vine Street Elementary School, 955 Vine Street, 1,350 feet southwest of the Project Site.

7.2.4.5 Existing Project Site Emissions

The Project Site is occupied by two buildings totaling 27,011 square feet and a 16,000 square-foot surface parking lot. As both buildings are vacant, there are no emissions of criteria pollutants produced on the Project Site.

7.3 Methodology

The air quality analysis conducted for the Project is consistent with the methods described in the SCAQMD CEQA Air Quality Handbook (1993 edition), as well as the updates to the CEQA Air Quality Handbook, as provided on the SCAQMD website. The SCAQMD recommends the use of the California Emissions Estimator Model (CalEEMod, version 2022.1) as a tool for quantifying emissions of air pollutants that will be generated by constructing and operating development projects. The analyses focuses on the potential change in air quality conditions due to Project implementation. Air pollutant emissions would result from both construction and operation of the Project. Specific methodologies used to evaluate these emissions are discussed below.

7.3.1 Construction

Sources of air pollutant emissions associated with construction activities include heavy-duty off-road diesel equipment and vehicular traffic to and from the Project construction site. Project-specific information was provided describing the schedule of construction activities and the equipment inventory required from the Applicant. Details pertaining to the schedule and equipment can be found in the **Appendix E** to this analysis.

The CalEEMod model provides default values for daily equipment usage rates and worker trip lengths, as well as emission factors for heavy-duty equipment, passenger vehicles, and haul trucks that have been derived by the CARB. Maximum daily emissions were quantified for each construction activity based on the number of equipment and daily hours of use, in addition to vehicle trips to and from the Project Site.

The SCAQMD recommends that air pollutant emissions be assessed for both regional scale and localized impacts. The regional emissions analysis includes both on-site and off-site sources of emissions, while the localized emissions analysis focuses only on sources of emissions that would be located on the Project Site.

Localized impacts were analyzed in accordance with the SCAQMD Localized Significance Threshold (LST) methodology.⁷⁴ The localized effects from on-site portion of daily emissions were evaluated at sensitive receptor locations potentially impacted by the Project according to the SCAQMD's localized significance thresholds (LST) methodology, which uses on-site mass emission look-up tables and Project-specific modeling, where appropriate.⁷⁵ SCAQMD provides LSTs applicable to the following criteria pollutants: NO_x, CO, PM₁₀, and PM_{2.5}. SCAQMD does not provide an LST for SO₂ since land use development projects typically result in negligible

⁷⁴ South Coast Air Quality Management District, Final Localized Significance Methodology, revised July 2008.

⁷⁵ South Coast Air Quality Management District, LST Methodology Appendix C-Mass Rate LST Look-Up Table, October 2009.

construction and long-term operation emissions of this pollutant. Since VOCs are not a criteria pollutant, there is no ambient standard or SCAQMD LST for VOCs. Due to the role VOCs play in O₃ formation, it is classified as a precursor pollutant, and only a regional emissions threshold has been established.

LSTs represent the maximum emissions from a project that are not expected to cause or contribute to an exceedance of the most stringent applicable federal or state ambient air quality standard and are developed based on the ambient concentrations of that pollutant for each source receptor area and distance to the nearest sensitive receptor. The mass rate look-up tables were developed for each source receptor area and can be used to determine whether or not a project may generate significant adverse localized air quality impacts. SCAQMD provides LST mass rate look-up tables for projects with active construction areas that are less than or equal to five acres. If the project exceeds the LST look-up values, then the SCAQMD recommends that project-specific air quality modeling must be performed.

In accordance with SCAQMD guidance, maximum daily emissions of NO_x, CO, PM₁₀, and PM_{2.5} from on-site sources during each construction activity were compared to LST values for a one-acre site having sensitive receptors within 25 meters (82 feet).⁷⁶

This is appropriate given the 0.936-acre site and the proximity of sensitive receptors immediately north and east of the Project Site.

The Basin is divided into 38 SRAs, each with its own set of maximum allowable LST values for on-site emissions sources during construction and operations based on locally monitored air quality. Maximum on-site emissions resulting from construction activities were quantified and assessed against the applicable LST values.

The significance criteria and analysis methodologies in the SCAQMD's CEQA Air Quality Handbook were used in evaluating impacts in the context of the CEQA significance criteria listed below. The SCAQMD localized significance thresholds (LSTs) for NO₂, CO, and PM₁₀ were initially published in June 2003 and revised in July 2008.⁷⁷ The LSTs for PM_{2.5} were established in October 2006.⁷⁸ Updated LSTs were published on the SCAQMD website on October 21, 2009.⁷⁹ **Table 7-3** presents the significance criteria for both construction and operational emissions.

⁷⁶ South Coast Air Quality Management District, Fact Sheet for Applying CalEEMod to Localized Significance Thresholds, 2008.

⁷⁷ South Coast Air Quality Management District, Fact Sheet for Applying CalEEMod to Localized Significance Thresholds, 2008.

⁷⁸ South Coast Air Quality Management District, Final – Methodology to Calculate Particulate Matter (PM) 2.5 and PM 2.5 Significance Thresholds, October 2006.

⁷⁹ South Coast Air Quality Management District, Final Localized Significance Threshold Methodology Appendix C – Mass Rate LST Look-Up Tables, October 21, 2009.

**Table 7-3
SCAQMD Emissions Thresholds**

Criteria Pollutant	Construction Emissions		Operation Emissions	
	Regional	Localized /a/	Regional	Localized /a/
Volatile Organic Compounds (VOC)	75	--	55	--
Nitrogen Oxides (NO _x)	100	74	55	74
Carbon Monoxide (CO)	550	680	550	680
Sulfur Oxides (SO _x)	150	--	150	--
Respirable Particulates (PM ₁₀)	150	5	150	2
Fine Particulates (PM _{2.5})	55	3	55	1

/a/ Localized significance thresholds assumed a 1-acre and 25-meter (82-foot) receptor distance in the Central LA source receptor area. The SCAQMD has not developed LST values for VOC or SO_x. Pursuant to SCAQMD guidance, sensitive receptors closer than 25 meters to a construction site are to use the LSTs for receptors at 25 meters (SCAQMD Final Localized Significance Threshold Methodology, June 2008).

Source: SCAQMD, South Coast AQMD Air Quality Significance Thresholds, 2019

7.3.2 Operation

CalEEMod also generates estimates of daily and annual emissions of air pollutants resulting from future operation of a project. Operational emissions of air pollutants are produced by mobile sources (vehicular travel) and stationary sources (utilities demand). The Project Site is serviced by the Los Angeles Department of Water and Power (LADWP), for which CalEEMod has derived default emissions factors for electricity and natural gas usage that are applied to the size and land use type of the Project in question. CalEEMod also generates estimated operational emissions associated water use, wastewater generation, and solid waste disposal.

Similar to construction, SCAQMD's CalEEMod software was used for the evaluation of Project emissions during operation. CalEEMod was used to calculate on-road fugitive dust, architectural coatings, landscape equipment, energy use, mobile source, and stationary source emissions. To determine if a significant air quality impact would occur, the net increase in regional and local operational emissions generated by the Project was compared against the SCAQMD's significance thresholds.⁸⁰

7.3.3 Toxic Air Contaminants Impacts

Potential TAC impacts are evaluated by conducting a qualitative analysis consistent with the CARB Handbook followed by a more detailed analysis (i.e., dispersion modeling), as necessary. The qualitative analysis consists of reviewing the Project to identify any new or modified TAC emissions sources. If the qualitative evaluation does not rule out significant impacts from a new source, or modification of an existing TAC emissions source, a more detailed analysis is conducted.

⁸⁰ SCAQMD, SCAQMD Air Quality Significance Thresholds, revised March 2015. SCAQMD based these thresholds, in part on the federal Clean Air Act and, to enable defining "significant" for CEQA purposes, defined the setting as the South Coast Air Basin. (See SCAQMD, CEQA Air Quality Handbook, April 1993, pp. 6-1-6-2.).

7.4 Thresholds of Significance

7.4.1 State CEQA Guidelines

In accordance with CEQA Guidelines Section 15332(d), approval of the project would not result in any significant effects relating to air quality.

7.4.2 SCAQMD Thresholds

In addition, the following criteria set forth in the SCAQMD's *CEQA Air Quality Handbook* serve as quantitative air quality standards to be used to evaluate project impacts under the Appendix G Thresholds. Under these thresholds, a significant threshold would occur when:⁸¹

7.4.2.1 Construction

- Regional emissions from both direct and indirect sources would exceed any of the following SCAQMD prescribed threshold levels: (1) 100 pounds per day for NO_x; (2) 75 pounds a day for VOC; (3) 150 pounds per day for PM₁₀ or SO_x; (4) 55 pounds per day for PM_{2.5}; and (5) 550 pounds per day for CO.
- Maximum on-site daily localized emissions exceed the LST, resulting in predicted ambient concentrations in the vicinity of the Project Site greater than the most stringent ambient air quality standards for CO (20 ppm [23,000 µg/m³] over a 1-hour period or 9.0 ppm [10,350 µg/m³] averaged over an 8-hour period) and NO₂ (0.18 ppm [339 µg/m³] over a 1-hour period, 0.1 ppm [188 µg/m³] over a three-year average of the 98th percentile of the daily maximum 1-hour average, or 0.03 ppm [57 µg/m³] averaged over an annual period).
- Maximum on-site localized PM₁₀ or PM_{2.5} emissions during construction exceed the applicable LSTs, resulting in predicted ambient concentrations in the vicinity of the Project Site to exceed the incremental 24-hour threshold of 10.4 µg/m³ or 1.0 µg/m³ PM₁₀ averaged over an annual period.

7.4.2.2 Operation

The City bases the determination of significance of operational air quality impacts on criteria set forth in the SCAQMD's *CEQA Air Quality Handbook*.⁸² However, as discussed above, the City has chosen to use Appendix G as the thresholds of significance for this analysis. Accordingly, the following serve as quantitative air quality standards to be used to evaluate project impacts under the Appendix G thresholds. Under these thresholds, a significant threshold would occur when:

- Operational emissions exceed 10 tons per year of volatile organic gases or any of the following SCAQMD prescribed threshold levels: (1) 55 pounds a day for VOC;⁸³ (2) 55 pounds per day

⁸¹ SCAQMD, SCAQMD Air Quality Significance Thresholds, revised March 2015.

⁸² SCAQMD, SCAQMD Air Quality Significance Thresholds, revised March 2015.

⁸³ For purposes of this analysis, emissions of VOC and reactive organic compounds (ROG) are used interchangeably since ROG represents approximately 99.9 percent of VOC emissions.

for NO_x; (3) 550 pounds per day for CO; (4) 150 pounds per day for SO_x; (5) 150 pounds per day for PM₁₀; and (6) 55 pounds per day for PM_{2.5}.⁸⁴

- Maximum on-site daily localized emissions exceed the LST, resulting in predicted ambient concentrations in the vicinity of the Project Site greater than the most stringent ambient air quality standards for CO (20 parts per million (ppm) over a 1-hour period or 9.0 ppm averaged over an 8-hour period) and NO₂ (0.18 ppm over a 1-hour period, 0.1 ppm over a 3-year average of the 98th percentile of the daily maximum 1-hour average, or 0.03 ppm averaged over an annual period).⁸⁵
- Maximum on-site localized operational PM₁₀ and PM_{2.5} emissions exceed the incremental 24-hour threshold of 2.5 µg/m³ or 1.0 µg/m³ PM₁₀ averaged over an annual period.⁸⁶
- The Project causes or contributes to an exceedance of the California 1-hour or 8-hour CO standards of 20 or 9.0 ppm, respectively; or
- The Project creates an odor nuisance pursuant to SCAQMD Rule 402.

7.4.2.3 Toxic Air Contaminants

The following criteria set forth in the SCAQMD's *CEQA Air Quality Handbook* serve as quantitative air quality standards to be used to evaluate project impacts under Appendix G thresholds. Under these thresholds, a significant threshold would occur when:⁸⁷

- The Project results in the exposure of sensitive receptors to carcinogenic or toxic air contaminants that exceed the maximum incremental cancer risk of 10 in one million or an acute or chronic hazard index of 1.0.⁸⁸ For projects with a maximum incremental cancer risk between 1 in one million and 10 in one million, a project would result in a significant impact if the cancer burden exceeds 0.5 excess cancer cases.

7.5 Project Impacts

The Project will comply with the applicable Los Angeles Green Building Code (LAGBC, 2023 version effective January 1, 2023)⁸⁹ and the applicable California Green Building Standards Code (CalGreen, 2022 version effective January 1, 2023).⁹⁰ The applicability is determined when the Project is submitted and accepted by plan check. During construction, the Project will recycle and reuse building and construction materials to the maximum extent feasible.

⁸⁴ SCAQMD Air Quality Significance Thresholds, www.aqmd.gov/docs/default-source/ceqa/handbook/scaqmd-air-quality-significance-thresholds.pdf, last updated March 2015.

⁸⁵ SCAQMD, Final Localized Significance Threshold Methodology, revised July 2008.

⁸⁶ SCAQMD, Final—Methodology to Calculate Particulate Matter (PM) 2.5 and PM_{2.5} Significance Thresholds, October 2006.

⁸⁷ SCAQMD, *CEQA Air Quality Handbook*, April 1993, Chapter 6 (Determining the Air Quality Significance of a Project) and Chapter 10 (Assessing Toxic Air Pollutants).

⁸⁸ Hazard index is the ratio of a toxic air contaminant's concentration divided by its Reference Concentration, or safe exposure level. If the hazard index exceeds one, people are exposed to levels of TACs that may pose noncancer health risks.

⁸⁹ City of Los Angeles Department of Building and Safety, Green Building, available at <http://ladbs.org/forms-publications/forms/green-building>, accessed on November 7, 2022.

⁹⁰ California Building Codes: <https://www.dgs.ca.gov/BSC/CALGreen>, accessed on November 7, 2022.

Energy efficiency and sustainability features would include native plants and drip/subsurface irrigation systems, individual metering or sub metering for water use, leak detection systems, and electric vehicle charging capacity. In addition, the landscaping on the outdoor decks will serve to help reduce solar heat gain and facilitate possible stormwater retention on-site.

The Project's infill location would promote the concentration of development in an urban location with extensive infrastructure and access to public transit facilities. The Project's proximity to public transportation would reduce vehicle miles traveled for residents, workers, and visitors who want options to driving cars.

7.5.1 Consistency with Plans

7.5.1.1 Air Quality Management Plan

The air quality plan applicable to the Project area is the 2016 AQMP. The 2016 AQMP is the SCAQMD plan for improving regional air quality in the Basin. The 2016 AQMP is the current management plan for continued progression toward clean air and compliance with State and federal requirements. It includes a comprehensive strategy aimed at controlling pollution from all sources, including stationary sources, on- and off-road mobile sources and area sources. The 2016 AQMP also incorporates current scientific information and meteorological air quality models. It also updates the federally approved 8-hour O₃ control plan with new commitments for short-term NO_x and VOC reductions. The 2016 AQMP includes short-term control measures related to facility modernization, energy efficiency, good management practices, market incentives, and emissions growth management.

As demonstrated in the following analyses, the Project would not result in significant regional emissions. The 2016 AQMP adapts previously conducted regional air quality analyses to account for the recent unexpected drought conditions and presents a revised approach to demonstrated attainment of the 2006 24-hour PM_{2.5} NAAQS for the Basin. Directly applicable to the Project, the 2016 AQMP proposes robust NO_x reductions from residential appliances. The Project would be required to comply with all new and existing regulatory measures set forth by the SCAQMD. Implementation of the Project would not interfere with air pollution control measures listed in the 2016 AQMP.

The Project Site is classified as "Highway Oriented Commercial" in the General Plan Framework, a classification that allows multi-family housing and commercial uses such as that proposed by the Project. As such, the RTP/SCS' assumptions about growth in the City accommodate the projected population and jobs on the Project Site. As a result, the Project would be consistent with the growth assumptions in the City's General Plan.

Because the AQMP accommodates growth forecasts from local General Plans, the emissions associated with this Project are accounted for and mitigated in the region's air quality attainment plans. The air quality impacts of development on the Project Site are accommodated in the region's emissions inventory for the 2016 RTP/SCS and 2016 AQMP. Therefore, Project impacts with respect to AQMP consistency would be less than significant.

7.5.1.2 City of Los Angeles Policies

The Project Site would offer convenient access to public transit and opportunities for walking and biking (including the provision of bicycle parking), thereby facilitating a reduction in VMT. In addition, the Project would be consistent with the existing land use pattern in the vicinity that concentrates urban density along major arterials and near transit options based on the following:

- The Project Site is within a HQTAs, which reflects areas with rail transit service or bus service where lines have peak headways of less than 15 minutes.⁹¹
- The Project Site is located in a Transit Priority Area, which are locations within one-half mile of a major transit stop with bus or rail transit service with frequencies of 15 minutes or less.
- The Project Site is nearby a qualified Major Transit Stop, which is the intersection of Santa Monica Boulevard and Vine Street, (665 feet south of the Site).⁹²
- There is substantial public transit service in the area, including:
 - Metro Line 4 which provides east-west service along Santa Monica Boulevard with a bus stop at Vine Street 680 feet south of the Project Site.
 - Metro Line 210 which provides north-south service along Vine Street with a bus stop at Lexington Avenue directly in front of the Project Site.
 - LADOT DASH (Hollywood) shuttle service on Vine Street, with a bus stop at Fountain Avenue 430 north of the Project Site.
- The Project will provide 14 short- and 106 long-term bicycle parking spaces on-site.
- Metro operates a bikeshare station on Vine Street and Fountain Avenue, 375 feet north of the Project Site.

The City's General Plan Air Quality Element identifies 30 policies with specific strategies for advancing the City's clean air goals. As illustrated in **Table 7-4**, the Project is consistent with the applicable policies in the Air Quality Element, as the Project would implement sustainability features that would reduce vehicular trips, reduce VMT, and encourage the use of alternative modes of transportation. Therefore, the Project would result in a less than significant impact related to consistency with the Air Quality Element.

⁹¹ Southern California Association of Governments Data Portal https://scag.ca.gov/sites/main/files/file-attachments/0903fconnectsocial_active-transportation.pdf?1606001530,

⁹² Major Transit Stop is a site containing a rail station or the intersection of two or more bus routes with a service interval of 15 minutes or less during the morning and afternoon peak commute periods. The stations or bus routes may be existing, under construction or included in the most recent Southern California Association of Governments (SCAG) Regional Transportation Plan (RTP).

Table 7-4
Project Consistency with City of Los Angeles General Plan Air Quality Element

Strategy	Project Consistency
Policy 1.3.1. Minimize particulate emissions from construction sites.	Consistent. The Project would minimize particulate emissions during construction through best practices and/or SCAQMD rules (e.g., Rule 403, Fugitive Dust).
Policy 1.3.2. Minimize particulate emissions from unpaved roads and parking lots associated with vehicular traffic.	Consistent. The Project would minimize particulate emissions from unpaved facilities through best practices and/or SCAQMD rules.
Policy 2.1.1. Utilize compressed work weeks and flextime, telecommuting, carpooling, vanpooling, public transit, and improve walking/bicycling related facilities in order to reduce vehicle trips and/or VMT as an employer and encourage the private sector to do the same to reduce work trips and traffic congestion.	Consistent. The proposed development would provide access to transportation commute options for both workers in the commercial space or for residents. The Project Site is served by public transit options, including Metro Line 4 on Santa Monica Boulevard and Line 210 on Vine Street. LADOT DASH (Hollywood) provides circulator shuttle service at a bus stop on Vine Street. Employees can benefit from the 14 short- and 106 long-term bicycle parking spaces on-site for residents and workers. Metro operates a bikeshare station on Vine Street and Fountain Avenue, 375 north of the Project Site. A co-work center on the second floor promotes telecommuting that would reduce work-related vehicle trips.
Policy 2.1.2. Facilitate and encourage the use of telecommunications (i.e., telecommuting) in both the public and private sectors, in order to reduce work trips.	Consistent. Residents could use high-speed telecommunications services as an alternative to driving to work. A June 2020 study by the National Bureau of Economic Research found that 37 percent of jobs can be performed entirely from home (https://www.nber.org/papers/w26948). As such, the Project could help reduce commuting to work through telecommuting.
Policy 2.2.1. Discourage single-occupant vehicle use through a variety of measures such as market incentive strategies, mode-shift incentives, trip reduction plans and ridesharing subsidies.	Consistent. The Project would discourage single-occupant vehicle use because of the limited parking (93 spaces) for residents and merchants. Residents, workers, and visitors can use public transit, including Metro Line 4 on Santa Monica Boulevard and Line 210 on Vine Street. LADOT DASH (Hollywood) provides circulator shuttle service at a bus stop on Vine Street. Employees can benefit from the 14 short- and 106 long-term bicycle parking spaces on-site for residents and workers. Metro operates a bikeshare station on Vine Street and Fountain Avenue, 375 north of the Project Site. A co-work center on the second floor promotes telecommuting that would reduce work-related vehicle trips.
Policy 2.2.2. Encourage multi-occupant vehicle travel and discourage single-occupant vehicle travel by instituting parking management practices.	Consistent. The Project is requesting parking in accordance with AB 2345 standards (Government Code Section 65915) which requires no more than 0.5 parking spaces per dwelling unit. The

**Table 7-4
Project Consistency with City of Los Angeles General Plan Air Quality Element**

Strategy	Project Consistency
	development would provide transportation options to residents and workers as an option to driving.
Policy 2.2.3. Minimize the use of single-occupant vehicles associated with special events or in areas and times of high levels of pedestrian activities.	Not Applicable. The residential and commercial development would not host special events. The Project would not impede the advancement of this Citywide policy.
Policy 3.2.1. Manage traffic congestion during peak hours.	Consistent. The Project is a low traffic generator because of the nature of residential uses, which generate peak hour vehicle trips that are lower than commercial, retail, and restaurant uses. Further, the Project would also minimize traffic congestion based on its location near transit opportunities, which would encourage the use of alternative modes of transportation. Residents, workers, and visitors can use public transit, including Metro Line 4 on Santa Monica Boulevard and Line 210 on Vine Street. LADOT DASH (Hollywood) provides circulator shuttle service at a bus stop on Vine Street. Employees can benefit from the 14 short- and 106 long-term bicycle parking spaces on-site for residents and workers. Metro operates a bikeshare station on Vine Street and Fountain Avenue, 375 north of the Project Site. A co-work center on the second floor promotes telecommuting that would reduce work-related vehicle trips.
Policy 4.1.1. Coordinate with all appropriate regional agencies on the implementation of strategies for the integration of land use, transportation, and air quality policies.	Consistent. The Project is being entitled through the City of Los Angeles, which coordinates with SCAG, Metro, and other regional agencies on the coordination of land use, air quality, and transportation policies.
Policy 4.1.2. Ensure that project level review and approval of land use development remains at the local level.	Consistent. The Project would be entitled and environmentally cleared at the local level.
Policy 4.2.1. Revise the City's General Plan/Community Plans to achieve a more compact, efficient urban form and to promote more transit-oriented development and mixed-use development.	Not Applicable. This policy calls for City updates to its General Plan.
Policy 4.2.2. Improve accessibility for the City's residents to places of employment, shopping centers and other establishments.	Consistent. The Project would be a mixed-use, infill development that would provide residents with proximate access to jobs, shopping, and other uses.
Policy 4.2.3. Ensure that new development is compatible with pedestrians, bicycles, transit, and alternative fuel vehicles.	Consistent. The Project would promote public transit, active transportation, and alternative fuel vehicles for residents, workers, and visitors, who can use public transit, including Metro Line 4 on Santa Monica Boulevard and Line 210 on Vine Street. LADOT DASH (Hollywood) provides circulator shuttle service at a bus stop on Vine Street.

**Table 7-4
Project Consistency with City of Los Angeles General Plan Air Quality Element**

Strategy	Project Consistency
	Employees can benefit from the 14 short- and 106 long-term bicycle parking spaces on-site for residents and workers. Metro operates a bikeshare station on Vine Street and Fountain Avenue, 375 north of the Project Site. A co-work center on the second floor promotes telecommuting that would reduce work-related vehicle trips. The Project would also include 29 spaces with conduits and supplies for future charging stations, of which ten would have electric vehicle charging stations.
Policy 4.2.4. Require that air quality impacts be a consideration in the review and approval of all discretionary projects.	Consistent. The Project's air quality impacts are analyzed in this document, and as discussed herein, all impacts with respect to air quality would be less than significant.
Policy 4.2.5. Emphasize trip reduction, alternative transit and congestion management measures for discretionary projects.	Consistent. The Project would support use of alternative transportation modes. The Project Site is well-served by public transit, including Metro Line 4 on Santa Monica Boulevard and Line 210 on Vine Street. LADOT DASH (Hollywood) provides circulator shuttle service at a bus stop on Vine Street. Employees can benefit from the 14 short- and 106 long-term bicycle parking spaces on-site for residents and workers. Metro operates a bikeshare station on Vine Street and Fountain Avenue, 375 north of the Project Site. A co-work center on the second floor promotes telecommuting that would reduce work-related vehicle trips.
Policy 4.3.1. Revise the City's General Plan/Community Plans to ensure that new or relocated sensitive receptors are located to minimize significant health risks posed by air pollution sources.	Not Applicable. This policy calls for City updates to its General Plan.
Policy 4.3.2. Revise the City's General Plan/Community Plans to ensure that new or relocated major air pollution sources are located to minimize significant health risks to sensitive receptors.	Not Applicable. This policy calls for City updates to its General Plan.
Policy 5.1.1. Make improvements in Harbor and airport operations and facilities in order to reduce air emissions.	Not Applicable. This policy calls for cleaner operations of the City's water port and airport facilities.
Policy 5.1.2. Effect a reduction in energy consumption and shift to non-polluting sources of energy in its buildings and operations.	Not Applicable. This policy calls for cleaner operations of the City's buildings and operations.
Policy 5.1.3. Have the Department of Water and Power make improvements at its in-basin power plants in order to reduce air emissions.	Not Applicable. This policy calls for cleaner operations of the City's Water and Power energy plants.

**Table 7-4
Project Consistency with City of Los Angeles General Plan Air Quality Element**

Strategy	Project Consistency
Policy 5.1.4. Reduce energy consumption and associated air emissions by encouraging waste reduction and recycling.	Consistent. The Project would be consistent with this policy by complying with Title 24, CALGreen, and other requirements to reduce solid waste and energy consumption. This includes the City's March 2010 ordinance (Council File 09-3029) that requires all mixed construction and demolition waste be taken to City-certified waste processors.
Policy 5.2.1. Reduce emissions from its own vehicles by continuing scheduled maintenance, inspection and vehicle replacement programs; by adhering to the State of California's emissions testing and monitoring programs; by using alternative fuel vehicles wherever feasible, in accordance with regulatory agencies and City Council policies.	Not Applicable. This policy calls for the City to gradually reduce the fleet emissions inventory from its vehicles through use of alternative fuels, improved maintenance practices, and related operational improvements. The Project's support of electric vehicles will continue the State's conversion to zero emission fleets that do not required engine inspections.
Policy 5.3.1. Support the development and use of equipment powered by electric or low-emitting fuels.	Consistent. The Project would be designed to meet the applicable requirements of the States Green Building Standards Code and the City of Los Angeles' Green Building Code, both of which promote a shift from natural gas use toward electrification of buildings. The Project would also include 29 spaces with conduits and supplies for future charging stations, of which ten would have electric vehicle charging stations.
Policy 6.1.1. Raise awareness through public-information and education programs of the actions that individuals can take to reduce air emissions.	Not Applicable. This policy calls for the City to promote clean air awareness through its public awareness programs.
Source: DKA Planning, 2022.	

7.5.2 Emissions

7.5.2.1 Construction

Construction-related emissions were estimated using the SCAQMD's CalEEMod 2022.1 model and a projected construction schedule of approximately 35 months. **Table 7-5** summarizes the estimated construction schedule that was modeled for air quality impacts.

**Table 7-5
Construction Schedule Assumptions**

Phase	Duration	Notes
Demolition	Months 1-3	Removal of 27,011 square feet of building floor area and 16,000 square feet of asphalt/concrete parking lot hauled 30 miles to landfill in 10-cubic yard capacity trucks.

**Table 7-5
Construction Schedule Assumptions**

Grading	Months 4-5	Approximately 10,000 cubic yards of soil (including swell factors for topsoil and dry clay) hauled 30 miles to landfill in 10-cubic yard capacity trucks. ⁹³
Trenching	Month 6-7 (6 weeks)	Trenching for utilities, including gas, water, electricity, and telecommunications.
Building Construction	Months 6-31	Footings and Foundation work (e.g., pouring concrete pads), framing, welding; installing mechanical, electrical, and plumbing. Floor assembly, cabinetry and carpentry, elevator installations, low voltage systems, trash management.
Architectural Coatings	Months 27-35	Application of interior and exterior coatings and sealants.
Source: DKA Planning, 2022.		

The Project would be required to comply with the following regulations, as applicable:

- SCAQMD Rule 403, would reduce the amount of particulate matter entrained in ambient air as a result of anthropogenic fugitive dust sources by requiring actions to prevent, reduce or mitigate fugitive dust emissions.
- SCAQMD Rule 1113, which limits the VOC content of architectural coatings.
- SCAQMD Rule 402, which states that a person shall not discharge from any source whatsoever such quantities of air contaminants or other materials which cause injury, detriment, nuisance, or annoyance to any considerable number of persons or to the public, or which endanger the comfort, repose, health, or safety of any such persons or the public, or which cause, or have a natural tendency to cause, injury or damage to business or property.
- In accordance with Section 2485 in Title 13 of the California Code of Regulations, the idling of all diesel-fueled commercial vehicles (with gross vehicle weight over 10,000 pounds) during construction would be limited to five minutes at any location.
- In accordance with Section 93115 in Title 17 of the California Code of Regulations, operation of any stationary, diesel-fueled, compression-ignition engines would meet specific fuel and fuel additive requirements and emissions standards.

Construction activity creates air quality impacts through the use of heavy-duty construction equipment and through vehicle trips generated by construction workers traveling to and from the Project Site. NO_x emissions would primarily result from the use of construction equipment and truck trips.

Fugitive dust emissions would peak during grading activities, where approximately 10,000 cubic yards of soil (including swell factors) would be exported from the Project Site. All construction projects in the Basin must comply with SCAQMD Rule 403 for fugitive dust. Rule 403 control requirements include measures to prevent the generation of visible dust plumes. Measures

⁹³ Estimates provided by the Applicant, July 2022. Assumes 8,439 cy with a soil swell percent of 18.5% = 10,000 cy.

include, but are not limited to, applying water and/or soil binders to uncovered areas, reestablishing ground cover as quickly as possible, utilizing a wheel washing system or other control measures to remove bulk material from tires and vehicle undercarriages before vehicles exit the Project Site, and maintaining effective cover over exposed areas. Compliance with Rule 403 would reduce regional PM_{2.5} and PM₁₀ emissions associated with construction activities by approximately 61 percent.

During the building finishing phase, the application of architectural coatings (e.g., paints) would potentially release VOCs (regulated by SCAQMD Rule 1113). The assessment of construction air quality impacts considers each of these potential sources. Construction emissions can vary substantially from day to day, depending on the level of activity, the specific type of operation and, for dust, the prevailing weather conditions.

As shown in **Table 7-6**, construction of the Project would produce VOC, NO_x, CO, SO_x, PM₁₀ and PM_{2.5} emissions that do not exceed the SCAQMD's regional thresholds. As a result, construction of the Project would not contribute substantially to an existing violation of air quality standards for regional pollutants (e.g., ozone). This impact is less than significant.

Table 7-6
Estimated Daily Construction Emissions

Construction Phase Year	Daily Emissions (Pounds Per Day)					
	VOC	NO _x	CO	SO _x	PM ₁₀	PM _{2.5}
2024	1.5	17.0	19.2	<0.1	4.0	1.9
2025	1.1	6.6	16.3	<0.1	2.1	0.7
2026	5.9	7.2	18.4	<0.1	2.4	0.7
Maximum Regional Total	5.9	17.0	19.2	<0.1	4.0	1.9
Regional Threshold	75	100	550	150	150	55
Exceed Threshold?	No	No	No	No	No	No
Maximum Localized Total	5.4	11.4	10.7	<0.1	2.6	1.5
Localized Threshold	N/A	74	680	N/A	5	3
Exceed Threshold?	N/A	No	No	N/A	No	No
<p>The construction dates are used for the modeling of air quality emissions in the CalEEMod software. If construction activities commence later than what is assumed in the environmental analysis, the actual emissions would be lower than analyzed because of the increasing penetration of newer equipment with lower certified emission levels. Assumes implementation of SCAQMD Rule 403 (Fugitive Dust Emissions)</p> <p>Source: DKA Planning, 2022 based on CalEEMod 2022.1 model runs. LST analyses based on 1-acre site with 25-meter distances to receptors in Central LA source receptor area. Estimates reflect the peak summer or winter season, whichever is higher. Totals may not add up due to rounding. Modeling sheets included in the Technical Appendix.</p>						

In addition to maximum daily regional emissions, maximum localized (on-site) emissions were quantified for each construction activity. The localized construction air quality analysis was conducted using the methodology promulgated by the SCAQMD. Look-up tables provided by the

SCAQMD were used to determine localized construction emissions thresholds for the Project.⁹⁴ LSTs represent the maximum emissions from a project that are not expected to cause or contribute to an exceedance of the most stringent applicable federal or state ambient air quality standard and are based on the most recent background ambient air quality monitoring data (2018-2020) for the Project area.

Maximum on-site daily construction emissions for NO_x, CO, PM₁₀, and PM_{2.5} were calculated using CalEEMod and compared to the applicable SCAQMD LSTs for the Central Los Angeles SRA based on construction site acreage that is less than or equal to one acre. Potential impacts were evaluated at the closest off-site sensitive receptor, which are the mental health center directly north of the Project Site and the residences five feet to the east on La Mirada and Lexington Avenues. The closest receptor distance on the SCAQMD mass rate LST look-up tables is 25 meters.

As shown in **Table 7-6**, above, the Project would produce emissions that do not exceed the SCAQMD's recommended localized standards of significance for NO₂ and CO during the construction phase. Similarly, construction activities would not produce PM₁₀ and PM_{2.5} emissions that exceed localized thresholds recommended by the SCAQMD. These estimates assume the use of Best Available Control Measures (BACMs) that address fugitive dust emissions of PM₁₀ and PM_{2.5} through SCAQMD Rule 403. This would include watering portions of the site that are disturbed during grading activities and minimizing tracking of dirt onto local streets. Therefore, construction impacts on localized air quality is less than significant.

7.5.2.2 Operation

Operational emissions of criteria pollutants would come from area, energy, and mobile sources. Area sources include hearths, consumer products such as household cleaners, architectural coatings for routine maintenance, and landscaping equipment. Energy sources include electricity and natural gas use for space heating and water heating. The CalEEMod program generates estimates of emissions from energy use based on the land use type and size. The Project would also produce long-term air quality impacts to the region primarily from motor vehicles that access the Project Site. The Project could add up to 892 vehicle trips to the local roadway network on a weekday at the start of operations in 2027.⁹⁵

As shown in **Table 7-7**, the Project's emissions would not exceed the SCAQMD's regional or localized significance thresholds. Therefore, the operational impacts of the Project on regional and localized air quality are considered less than significant.

Table 7-7
Estimated Daily Operations Emissions

Emissions Source	Daily Emissions (Pounds Per Day)					
	VOC	NO _x	CO	SO _x	PM ₁₀	PM _{2.5}
Area Sources	4.4	0.1	10.6	<0.1	<0.1	<0.1
Energy Sources	<0.1	0.6	0.3	<0.1	<0.1	<0.1
Mobile Sources	2.6	1.6	17.9	<0.1	1.5	0.3

⁹⁴ South Coast Air Quality Management District, LST Methodology Appendix C-Mass Rate LST Look-up Table, revised October 2009.

⁹⁵ Gibson Transportation Consulting, Inc. Transportation Assessment for the 1200 Vine Street Project; November 2, 2022.

**Table 7-7
Estimated Daily Operations Emissions**

Net Regional Total	7.1	2.3	28.9	<0.1	1.6	0.3
Regional Significance Threshold	55	55	550	150	150	55
Exceed Threshold?	No	No	No	No	No	No
Net Localized Total	4.4	0.7	10.9	<0.1	<0.1	<0.1
Localized Significance Threshold	N/A	74	680	N/A	2	1
Exceed Threshold?	N/A	No	No	N/A	No	No
LST analyses based on 1-acre site with 25-meter distances to receptors in Central Los Angeles SRA Source: DKA Planning, 2022 based on CalEEMod 2022.1 model runs (included in the Technical Appendix). Totals reflect the summer season maximum and may not add up due to rounding.						

7.5.3 Sensitive Receptors

7.5.3.1 Construction

Construction of the Project could expose sensitive receptors to substantial pollutant concentrations if maximum daily emissions of regulated pollutants generated by sources located on and/or near the Project Site exceeded the applicable LST values presented in **Table 7-3**, or if construction activities generated significant emissions of TACs that could result in carcinogenic risks or non-carcinogenic hazards exceeding the SCAQMD Air Quality Significance Thresholds of 10 excess cancers per million or non-carcinogenic Hazard Index greater than 1.0, respectively. As discussed above, the LST values were derived by the SCAQMD for the criteria pollutants NO_x, CO, PM₁₀, and PM_{2.5} to prevent the occurrence of concentrations exceeding the air quality standards at sensitive receptor locations based on proximity and construction site size.

As shown in **Table 7-6**, during construction of the Project, maximum daily localized unmitigated emissions of NO₂, CO, PM₁₀, and PM_{2.5} from sources on the Project Site would remain below each of the respective LST values. Unmitigated maximum daily localized emissions would not exceed any of the localized standards for receptors that are within 25 meters of the Project's construction activities. Therefore, based on SCAQMD guidance, localized emissions of criteria pollutants would not have the potential to expose sensitive receptors to substantial concentrations that would present a public health concern.

The primary TAC that would be generated by construction activities is diesel PM, which would be released from the exhaust stacks of construction equipment. The construction emissions modeling conservatively assumed that all equipment present on the Project Site would be operating simultaneously throughout most of the day, while in all likelihood this would rarely be the case. Average daily emissions of diesel PM would be less than one pound per day throughout the course of Project construction. Therefore, the magnitude of daily diesel PM emissions, would not be sufficient to result in substantial pollutant concentrations at off-site locations nearby.

Furthermore, according to SCAQMD methodology, health risks from carcinogenic air toxics are usually described in terms of individual cancer risk. "Individual Cancer Risk" is the likelihood that a person exposed to concentrations of TACs over a 30-year period will contract cancer based on the use of standard risk-assessment methodology. The entire duration of construction activities associated with implementation of the Project is anticipated to be approximately 35 months, and the

magnitude of daily diesel PM emissions will vary over this time period. No residual emissions and corresponding individual cancer risk are anticipated after construction. Because there is such a short-term exposure period, construction TAC emissions would result in a less than significant impact. Therefore, construction of the Project would not expose sensitive receptors to substantial diesel PM concentrations, and this impact would be less than significant.

7.5.3.2 Operation

The Project Site would be redeveloped with multi-family residences and commercial uses, land uses that are not typically associated with TAC emissions. Typical sources of acutely and chronically hazardous TACs include industrial manufacturing processes (e.g., chrome plating, electrical manufacturing, petroleum refinery). The Project would not include these types of potential industrial manufacturing process sources. It is expected that quantities of hazardous TACs generated on-site (e.g., cleaning solvents, paints, landscape pesticides) for the types of proposed land uses would be below thresholds warranting further study under California Accidental Release Program.

When considering potential air quality impacts under CEQA, consideration is given to the location of sensitive receptors within close proximity of land uses that emit TACs. CARB has published and adopted the Air Quality and Land Use Handbook: A Community Health Perspective, which provides recommendations regarding the siting of new sensitive land uses near potential sources of air toxic emissions (e.g., freeways, distribution centers, rail yards, ports, refineries, chrome plating facilities, dry cleaners, and gasoline dispensing facilities).⁹⁶ The SCAQMD adopted similar recommendations in its Guidance Document for Addressing Air Quality Issues in General Plans and Local Planning.⁹⁷ Together, the CARB and SCAQMD guidelines recommend siting distances for both the development of sensitive land uses in proximity to TAC sources and the addition of new TAC sources in proximity to existing sensitive land uses.

The primary sources of potential air toxics associated with Project operations include DPM from delivery trucks (e.g., truck traffic on local streets and idling on adjacent streets) and to a lesser extent, facility operations (e.g., natural gas fired boilers). However, these activities, and the land uses associated with the Project, are not considered land uses that generate substantial TAC emissions. It should be noted that the SCAQMD recommends that health risk assessments (HRAs) be conducted for substantial individual sources of DPM (e.g., truck stops and warehouse distribution facilities that generate more than 100 trucks per day or more than 40 trucks with operating transport refrigeration units) and has provided guidance for analyzing mobile source diesel emissions.⁹⁸ Based on this guidance, the Project would not include these types of land uses and is not considered to be a substantial source of DPM warranting a refined HRA since daily truck trips to the Project Site would not exceed 100 trucks per day or more than 40 trucks with operating transport refrigeration units. In addition, the CARB-mandated airborne toxic control

⁹⁶ California Air Resources Board, Air Quality and Land Use Handbook, a Community Health Perspective, April 2005.

⁹⁷ South Coast Air Quality Management District, Guidance Document for Addressing Air Quality Issues in General Plans and Local Planning, May 6, 2005.

⁹⁸ South Coast Air Quality Management District, Health Risk Assessment Guidance for Analyzing Cancer Risks from Mobile Source Diesel Idling Emissions for CEQA Air Quality Analysis, 2002.

measures (ATCM) limits diesel-fueled commercial vehicles (delivery trucks) to idle for no more than five minutes at any given time, which would further limit diesel particulate emissions.

As the Project would not contain substantial TAC sources and is consistent with the CARB and SCAQMD guidelines, the Project would not result in the exposure of off-site sensitive receptors to carcinogenic or toxic air contaminants that exceed the maximum incremental cancer risk of 10 in one million or an acute or chronic hazard index of 1.0, and potential TAC impacts would be less than significant.

The Project would generate long-term emissions on-site from area and energy sources that would generate negligible pollutant concentrations of CO, NO₂, PM_{2.5}, or PM₁₀ at nearby sensitive receptors. While long-term operations of the Project would add traffic to local roads that produces off-site emissions, these would not result in exceedances of CO air quality standards at roadways in the area due to three key factors. First, CO hotspots are extremely rare and only occur in the presence of unusual atmospheric conditions and extremely cold conditions, neither of which applies to this Project area. Second, auto-related emissions of CO continue to decline because of advances in fuel combustion technology in the vehicle fleet. Finally, the Project would not contribute to the levels of congestion that would be needed to produce emissions concentrations needed to trigger a CO hotspot, as it would add 892 vehicle trips to the local roadway network on weekdays when the development could be fully leased and operational in 2027.⁹⁹ The majority of vehicle-related impacts at the Project Site would come from up to 97 and 95 vehicles entering and exiting the development during the peak A.M. and P.M. hours, respectively.¹⁰⁰ This would represent 3.8 percent of the 2,552 vehicles currently traveling north and south on Vine Street at Lexington Avenue in the A.M. peak hour.¹⁰¹ Assuming peak hour volumes represent ten percent of daily volumes, this intersection carries 25,520 daily vehicle trips, well below the traffic volumes that would be needed to generate CO exceedances of the ambient air quality standard.¹⁰²

Finally, the Project would not result in any substantial emissions of TACs during the construction or operations phase. During the construction phase, the primary air quality impacts would be associated with the combustion of diesel fuels, which produce exhaust-related particulate matter that is considered a toxic air contaminant by CARB based on chronic exposure to these emissions.¹⁰³ However, construction activities would not produce chronic, long-term exposure to diesel particulate matter. During long-term project operations, the Project does not include typical sources of acutely and chronically hazardous TACs such as industrial manufacturing processes and automotive repair facilities. As a result, the Project would not create substantial concentrations of TACs.

⁹⁹ Gibson Transportation Consulting, Inc. Transportation Assessment for the 1200 Vine Street Project; November 2, 2022.

¹⁰⁰ Gibson Transportation Consulting, Inc. Transportation Assessment for the 1200 Vine Street Project; November 2, 2022.

¹⁰¹ Gibson Transportation Consulting, Inc. Transportation Assessment for the 1200 Vine Street Project; November 2, 2022.

¹⁰² South Coast Air Quality Management District; 2003 AQMP. As discussed in the 2003 AQMP, the 1992 CO Plan included a CO hotspot analysis at four intersections in the peak A.M. and P.M. time periods, including Long Beach Boulevard and Imperial Highway (Lynwood), Wilshire Boulevard and Veteran Avenue (Westwood), Sunset Boulevard and Highland Avenue (Hollywood), and La Cienega Boulevard and Century Boulevard (Inglewood). The busiest intersection was Wilshire and Veteran, used by 100,000 vehicles per day. The 2003 AQMP estimated a 4.6 ppm one-hour concentration at this intersection, which meant that an exceedance (20 ppm) would not occur until daily traffic exceeded more than 400,000 vehicles per day.

¹⁰³ California Office of Environmental Health Hazard Assessment. Health Effects of Diesel Exhaust. [www.http://oehha.ca.gov/public_info/facts/dieselfacts.html](http://oehha.ca.gov/public_info/facts/dieselfacts.html)

In addition, the SCAQMD recommends that health risk assessments be conducted for substantial sources of diesel particulate emissions (e.g., truck stops and warehouse distribution facilities) and has provided guidance for analyzing mobile source diesel emissions.¹⁰⁴ The Project would not generate a substantial number of truck trips. Based on the limited activity of TAC sources, the Project would not warrant the need for a health risk assessment associated with on-site activities. Therefore, the Project's operational impacts on local sensitive receptors would be less than significant.

7.5.4 Odors

The Project would not result in activities that create objectionable odors. The Project is a residential and commercial development that would not include any activities typically associated with unpleasant odors and local nuisances (e.g., rendering facilities, dry cleaners). SCAQMD regulations that govern nuisances (i.e., Rule 402, Nuisances) would regulate any occasional odors. As a result, any odor impacts from the Project would be considered less than significant.

7.6 Conclusion

For all the foregoing reasons, the Project would not have a significant impact related to air quality, and, therefore, the Project would comply with CCR Section 15332(d).

¹⁰⁴ South Coast Air Quality Management District, Health Risk Assessment Guidance for Analyzing Cancer Risks from Mobile Source Diesel Emissions, December 2002.

8 Discussion of CCR Section 15332(d): Water Quality

Approval of the project would not result in any significant effects relating to traffic, noise, air quality, or water quality.¹⁰⁵

This section is based on the following item, included as **Appendix F** of this CE:

F Water Resources Technical Report, Fuscoe Engineering, October 25, 2022

8.1 Regulatory Framework

8.1.1 Surface Water Hydrology

8.1.1.1 County of Los Angeles Hydrology Manual

The Project Site is located within the Ballona Creek Watershed, which covers approximately 130 square miles. The Los Angeles County Flood Control District (LACFCD) is responsible for providing flood protection, water conservation, recreation, and aesthetic enhancement within this entire watershed. The Los Angeles County Flood Control District (LACFCD) is responsible for providing flood protection, water conservation, recreation and aesthetic enhancement within this entire watershed. The Los Angeles County Department of Public Works (LACDPW) developed a Hydrology Manual (January 2006), which establishes the LACDPW hydrologic design procedures based on historic rainfall and runoff data collected within the County.

8.1.1.2 Los Angeles Municipal Code

Any proposed drainage improvements within the street right-of-way or any other property owned by, to be owned by, or under control of the City requires approval through the B-Permit process (LAMC Section 62.105). Through the B-Permit process, storm drain installation plans which include any connections to the City's storm drain system from a property line to a catch basin or storm drainpipe, are subject to review and approval by the City of Los Angeles Department of Public Works, Bureau of Engineering.

8.1.2 Surface Water Quality

8.1.2.1 Clean Water Act

In 1972, the federal Clean Water Act (CWA) was established, which provided the regulatory framework for surface water quality protection. The United States Congress amended the CWA in 1987 to specifically regulate discharges to waters of the United States from public storm drain systems and storm water flows from industrial facilities, including construction sites, and require such discharges be regulated through permits under the National Pollutant Discharge Elimination System (NPDES).¹⁰⁶ CWA regulation calls for the implementation of Best Management Practices (BMPs) to reduce or prevent the discharge of pollutants from these activities to the Maximum

¹⁰⁵ Each of these topic areas (traffic, noise, air quality, and water quality) is discussed in its own section.

¹⁰⁶ CWA Section 402(p).

Extent Practicable (MEP) for urban runoff and meeting the Best Available Technology Economically Achievable (BAT) and Best Conventional Pollutant Control Technology (BCT) standards for construction storm water. Regulations and permits have been implemented at the federal, state, and local level to form a comprehensive regulatory framework to serve and protect the quality of the nation's surface water resources.

The CWA Federal Anti-Degradation Policy [40 Code of Federal Regulations (CFR) Section 131.12] requires states to develop statewide anti-degradation policies and identify methods for implementing them. Pursuant to the CFR, state anti-degradation policies and implementation methods shall, at a minimum, protect and maintain (1) existing in-stream water uses; (2) existing water quality, where the quality of the waters exceeds levels necessary to support existing beneficial uses, unless the state finds that allowing lower water quality is necessary to accommodate economic and social development in the area; and (3) water quality in waters considered an outstanding national resource.

8.1.2.2 Board Basin Plan for the Coastal Watersheds of Los Angeles and Ventura Counties

As required by the California Water Code (CWC), the LARWQCB has adopted a plan entitled "Water Quality Control Plan, Los Angeles Region: Basin Plan for the Coastal Watersheds of Los Angeles and Ventura Counties" (Basin Plan). Specifically, the Basin Plan designates beneficial uses for surface and groundwaters, sets narrative and numerical objectives that must be attained or maintained to protect the designated beneficial uses and conform to the state's antidegradation policy, and describes implementation programs to protect all waters in the Los Angeles Region. In addition, the Basin Plan incorporates (by reference) all applicable state and regional board plans and policies and other pertinent water quality policies and regulations. Those of other agencies are referenced in appropriate sections throughout the Basin Plan.

8.1.2.3 The General Permit for Construction Activities

SWRCB Order No. 2009-0009-DWQ known as the "Construction General Permit" was adopted on September 2, 2009 and was amended by Order No. 2010-0014-DWQ on February 14, 2011 and Order No 2012-0006-DWQ which became effective on July 17, 2012. This NPDES permit establishes a risk-based approach to stormwater control requirements for construction projects by identifying three project risk levels.

California mandates requirements for all construction activities disturbing more than one acre of land to develop and implement Stormwater Pollution Prevention Plans (SWPPPs). The SWPPP documents the selection and implementation of BMPs for a specific construction project, charging owners with stormwater quality management responsibilities. A construction site subject to the General Permit must prepare and implement a SWPPP that meets the requirements of the General Permit.

8.1.2.4 Los Angeles County Municipal Storm Water System (MS4) Permit

As described above, USEPA regulations require that MS4 permittees implement a program to monitor and control pollutants being discharged to the municipal system from both industrial and commercial projects that contribute a substantial pollutant load to the MS4. On December 13,

2001, the NPDES Permit or MS4 permit were adopted for municipal stormwater and urban runoff discharges within Los Angeles County, covering 84 cities and most of the unincorporated areas of Los Angeles County.

8.1.2.5 Los Angeles Municipal Code

Section 64.70 of LAMC sets forth the City's Stormwater and Urban Runoff Pollution Control Ordinance. The ordinance prohibits the discharge of the following items into any storm drain systems:

- Any liquids, solids, or gasses which by reason of their nature or quantity are flammable, reactive, explosive, corrosive, or radioactive, or by interaction with other materials could result in fire, explosion or injury.
- Any solid or viscous materials, which could cause obstruction to the flow or operation of the storm drain system.
- Any pollutant that injures or constitutes a hazard to human, animal, plant or fish life, or creates a public nuisance.
- Any noxious or malodorous liquid, gas, or solid in sufficient quantity, either singly or by interaction with other materials, which creates a public nuisance, hazard to life, or inhibits authorized entry of any person into the storm drain system.
- Any medical, infectious, toxic or hazardous material or waste.

Earthwork activities, including grading, are overseen by the Los Angeles Building Code, which is contained in LAMC, Chapter IX, Article 1. Section 91.7013 contains regulations pertaining to erosion control and drainage devices and Section 91.7014 provide requirements for flood, mudflow protection and general construction requirements.

8.1.2.6 Low Impact Development

LID is a stormwater strategy that is used to mitigate the impacts of runoff and stormwater pollution as close to its source as possible. Urban runoff discharged may contain pollutants such as trash and debris, bacteria and viruses, oil and grease, sediments, nutrients, metals, and toxic chemicals that can negatively affect the ocean, rivers, plant and animal life, and public health. LID encompasses a set of site design approaches and BMPs that are designed to address runoff and pollution at the source. These LID practices can effectively remove nutrients, bacteria, and metals, while reducing the volume and intensity of stormwater flows.

The Project is subject to runoff mitigation in a manner that captures or treats rainwater at its source, while utilizing natural resources. Stormwater runoff shall either be infiltrated, evapotranspired, captured and used, or treated through high removal efficiency BMPs, onsite, through stormwater management techniques that comply with provisions of the City of Los Angeles Planning and Land Development Handbook for Low Impact Development (May 2016). The LARWQCB has a BMP Hierarchy in which the project must follow when selecting the type or types of BMPs to be constructed on site. The following is the BMP Hierarchy, per Order No. R4-2012-0175 as amended by Order WQ 2015-0075 NPDES NO. CAS004001:

1. On-site infiltration,
2. On-site bioretention and/or harvest and use,
3. On-site biofiltration, off-site ground water replenishment, and/or off-site retrofit

8.1.2.7 Hydromodification

The Project is not required to implement hydrologic control measures as mitigation for hydromodification impacts. In addition, as described below, implementation of the Project will result in a reduction of peak flows and volumes as compared to existing conditions, thereby satisfying hydromodification requirements in addition to the receiving water exemption.

8.1.2.8 Ballona Creek Watershed Enhanced Watershed Management Program

The County of Los Angeles, the City of Los Angeles and all other cities in the Los Angeles Watershed are responsible for the implementation of watershed improvement plans or Enhanced Watershed Management Programs (EWMP) to improve water quality and assist in meeting the Total Maximum Daily Load (TMDL) milestones. An EWMP for the Los Angeles River Watershed (EWMP, June 2014), was prepared with the City of Los Angeles as the lead coordinating agency. The objective of the EWMP Plan is to determine the network of control measures (often referred to as best management practices [BMPs]) that will achieve required pollutant reductions while also providing multiple benefits to the community and leveraging sustainable green infrastructure practices.

The Project Site, located in the Ballona Creek Watershed, falls within the EWMP. The EWMP does not identify any regional BMP projects in the vicinity of the Project. Therefore, LID BMPs will be implemented at the individual parcels associated with the Project to meet the local MS4 Permit requirements.

8.1.3 Groundwater

8.1.3.1 California Groundwater Sustainability Act

On Sept. 16, 2014, California Governor Jerry Brown signed into law a three-bill legislative package, known as the Sustainable Groundwater Management Act of 2014 (SGMA). The SGMA provides a framework for sustainable management of groundwater supplies by local authorities, with a limited role for state intervention only if necessary, to protect the resource. The SGMA requires the formation of local groundwater sustainability agencies (GSAs) that must assess conditions in their local water basins and adopt locally based management plans. The act provides substantial time – 20 years – for GSAs to implement plans and achieve long-term groundwater sustainability. It protects existing surface water and groundwater rights and does not impact current drought response measures. The California Water Commission (CWC) requires a statewide prioritization of California's groundwater basins using the following eight criteria: 1. Overlying population; 2. Projected growth of overlying population; 3. Public supply wells; 4. Total wells; 5. Overlying irrigated acreage; 6. Reliance on groundwater as the primary source of water; 7. Impacts on the groundwater—including overdraft, subsidence, saline intrusion, and other water quality degradation; 8. Any other information determined to be relevant by the Department.

The Project Site is not located within a high priority California Statewide Groundwater Elevation Monitoring groundwater basin. It is located within the San Fernando Valley basin, which currently does not have any California Statewide Groundwater Elevation Monitoring System wells. The subbasin is under the Los Angeles GSA, but there are currently no GSPs which include this location.^{107, 108} GSAs responsible for high-and medium-priority basins must adopt groundwater sustainability plans within five to seven years. Plans must include a physical description of the basin, including groundwater levels, groundwater quality, subsidence, information on groundwater-surface water interaction, data on historical and projected water demands and supplies, monitoring and management provisions, and a description of how the plan will affect other plans, including city and county general plans. Plans will be evaluated every five years.

8.1.3.2 Basin Plan for Coastal Watersheds of Los Angeles and Ventura Counties

As required by the CWC, the LARWQCB has adopted a plan entitled “Water Quality Control Plan, Los Angeles Region: Basin Plan for the Coastal Watersheds of Los Angeles and Ventura Counties” (Basin Plan). Specifically, the Basin Plan designates beneficial uses for surface and groundwaters, sets narrative and numerical objectives that must be attained or maintained to protect the designated beneficial uses and conform to the state's anti-degradation policy, and describes implementation programs to protect all waters in the Los Angeles Region. In addition, the Basin Plan incorporates (by reference) all applicable state and regional board plans and policies and other pertinent water quality policies and regulations. Those of other agencies are referenced in appropriate sections throughout the Basin Plan. The Basin Plan is a resource for the LARWQCB and others who use water and/or discharge wastewater in the Los Angeles Region. Other agencies and organizations involved in environmental permitting and resource management activities also use the Basin Plan. Finally, the Basin Plan provides valuable information to the public about local water quality issues.

8.2 Environmental Setting

8.2.1 Surface Water Hydrology

Stormwater runoff is collected from the Project Site and conveyed through an offsite storm drain facility along Vine Street, with excess stormwater flowing further down to El Centro Avenue. Existing city records per NavigateLA, and per a Project Site visitation, indicate that there is one (1) existing 7-foot diameter storm drain in Vine St resides west of the Project. The storm drain on Vine Street is owned and maintained by the City of Los Angeles. This 84-inch (7-foot) main line in Vine Street flows in a southwesterly direction and discharges into Ballona Creek Reach 1.¹⁰⁹

There are two (2) existing catch basins at the southwest corner of the project site, the intersection between Vine Street and Lexington Avenue (one on each respective street). Excess flows from Vine Street and along Lexington Avenue discharge towards these catch basins. The two catch basins connect to the 84-inch storm drain pipe along Vine Street through a 12-inch storm drain pipe, which ultimately flow south. These drains eventually discharge into Ballona Creek Reach 1. All the stormwater runoff from the Project Site, which is within Ballona Creek watershed, is

¹⁰⁷ <https://sgma.water.ca.gov/portal/#gsa>

¹⁰⁸ <https://sgma.water.ca.gov/portal/#gsp>

¹⁰⁹ NavigateLA, Stormwater layer: <http://navigatepla.lacity.org/navigatepla/>

discharged into Ballona Creek Reach 1 which makes its way to the Ballona Creek Estuary and ultimately into the Pacific Ocean. Ballona Creek Reach 1 is approximately 2 miles long, spanning from Cochran Avenue to National Boulevard and covering areas above National Boulevard. It includes the Los Angeles neighborhoods of West Hollywood and portions of other cities of Los Angeles County.

There are no known existing storm drain deficiencies or capacity issues within the storm drains that collect runoff from the Project Site. The Stormwater Division has mentioned that if the project is reducing the stormwater runoff, the City of Los Angeles does not anticipate conflicts. There are no known existing storm drain deficiencies or capacity issues within the storm drains that collect runoff from the Project Site. If the Project is reducing the stormwater runoff, the City does not anticipate any conflicts.

According to the Federal Emergency Management Agency's (FEMA) Flood Insurance Rate Map (FIRM) No. 06037C1605F, dated September 26, 2008, the Project Site is located within Zone X outside of the 0.2% chance of flooding. Zone X depicts areas determined to be outside the 0.2% (500-year) annual chance floodplain. Therefore, the processing of a letter of map revision or conditional letter of map revision (LOMR/CLOMR) through FEMA will not be required for the Project.

8.2.2 Surface Water Quality

Within the urban environment of the Project, stormwater runoff occurs during and shortly after rain events. The volume of runoff depends on the intensity and duration of the storm event and the imperviousness of the drainage area. Typical urban pollutants associated with stormwater runoff following rain events includes sediment, trash, bacteria, metals, nutrients, and potentially organics and pesticides. The source of contaminants is wide ranging and includes all areas where rainfall occurs along with atmospheric deposition. Therefore, sources of contaminants within urban areas include roadways, building tops, parking lots, landscape areas and maintenance areas.

To reduce contaminant loads from entering the storm drain system, the City conducts routine street cleaning operations as well as periodic cleaning and maintenance of the catch basins to reduce stormwater pollution within the storm drain system. The City also installs catch basin screens to reduce trash from entering the catch basins.

Under existing conditions, the Project Site is commercial. Stormwater that leaves the Project Site enters into an existing catch basin or exits onto adjacent streets and remains untreated. Ultimately flows discharge into curbside inlets on southernly edge on Lexington Avenue or westerly edge of Vine Street, where it gets picked up by the public storm drain system. Anticipated pollutants consistent with parking lots, building areas and landscaping include total suspended solids (TSS), oil/grease, heavy metals, nutrients, pesticides and trash.

8.2.3 Groundwater

The Project Site is located within the Hollywood subbasin, which underlies along the northeastern part of the Los Angeles Coastal Plain Groundwater Basin. This subbasin reside in the Los Angeles GSA, which does not currently have a GSP for the basin. The subbasin is bounded on the north

by Santa Monica Mountains and the Hollywood fault, on the east by the Elysian Hills, on the west by the Inglewood fault zone, and on the south by the La Brea High, formed by an anticline that brings impermeable rocks close to the surface. Groundwater in the Hollywood Subbasin is mainly produced from Pleistocene age alluvial sands and gravels.¹¹⁰

According to the California Department of Water Resources, the annual precipitation throughout the Hollywood subbasin ranges from 12 to 14 inches with an average of around 13 inches. The Hollywood subbasin has a surface area of 10,500 acres and a groundwater storage capacity of approximately 200,000 acre/feet.¹¹¹ Historically, groundwater flow is generally westward through the subbasin toward the Inglewood fault. Recharge of the Hollywood Basin occurs primarily by percolation of precipitation and stream flow from the higher areas to the north. Subsurface inflow may take place to a limited extent from underflow through fractured rock of the Santa Monica Mountains and potentially from underflow around the La Brea High.

As noted in the Geotechnical Investigation (included as **Appendix H** to this CE) for the Project dated December 9, 2021, the California Geological Survey Seismic Hazard Evaluation Report 026 Plat 1.2 entitled “Historically Highest Ground Water Contours” indicates that the historically high groundwater level in the area is approximately 37 feet below the ground surface. Groundwater was encountered at depths between 20 and 21.5 feet below the ambient site grade in exploratory excavations. The closest neighboring active monitoring wells to the project site is Well Number 2671A with a groundwater depth of 22 feet and a water surface elevation of 261.60 feet (recorded 01.24.2022), located approximately 0.6 miles southeast of the project site. There is not a high potential for contaminated soils to be encountered, but if the contaminated soils are found within the excavation limits, contaminated soils would be collected within the excavated material, removed from the Project Site, and disposed of in accordance with all applicable regulatory requirements.

8.3 Project Impacts

8.3.1 Construction

8.3.1.1 Surface Water Hydrology and Quality

Implementation of the Project would result in construction activities that includes demolition of the existing building on-site and excavation of existing soils. Construction activities have the potential to temporarily alter the existing drainage patterns of the Project Site and also increase the permeability of the site based on increased pervious surface coverage during construction. Exposed pervious surfaces also have the potential for erosion, scour, and increased sediment and associated pollutants discharging from the Project Site during construction activities. The main pollutant of concern during construction is typically sediment and soil particles that discharge off-site due to wind, rain, and construction patterns.

The Project would be subject to the Construction General Permit and must prepare and implement a Stormwater Pollution Prevention Plan (SWPPP) that meets the requirements of the General

¹¹⁰ California’s Groundwater, Bulletin 118. Department of Water Resources. February 2004.

¹¹¹ California’s Groundwater, Bulletin 118. Department of Water Resources. February 2004.

Permit. In the event exceedances of receiving water quality objectives are observed, measures must be taken and documented within the SWPPP to improve discharge water quality and runoff effluent. This may include but not be limited to increasing the size of existing BMPs, adding more BMPs to the drainage area, additional filtering, and/or a reduction in active grading area.

Prior to commencement of construction activities, the General Permit requires the Project SWPPP to be prepared in accordance with the site-specific information including grading limits, BMPs for each phase, schedule and sediment risk analyses. In accordance with the General Permit, the construction SWPPP must be made available for review upon request, shall describe construction BMPs that address pollutant source reduction, and provide measures/controls necessary to mitigate potential pollutant sources. These measures/controls include, but are not limited to: erosion controls, sediment controls, tracking controls, non-storm water management, materials & waste management, and good housekeeping practices.

The applicant is not required by the City to provide a Notice of Intent, WDID issued from the SWRCB, or SWPPP to ensure the potential for soil erosion and construction are minimized, due to the Project disturbing less than one (1) acre of land. The phases of construction will define the maximum amount of soil disturbed, the appropriately sized sediment basins, and other control measures to accommodate all active soil disturbance areas and the appropriate monitoring and sampling plans.

Through compliance with the General Permit including implementation of BMPs appropriate for each major phase of construction, and compliance with applicable City grading regulations, construction of the Project would not cause flooding, substantially increase or decrease the amount of surface water in a water body, or result in a permanent, adverse change to flow direction. The construction of the Project would also not result in discharges that would cause: (1) pollution that would impact the quality of waters of the state to a degree which negatively impacts beneficial uses of the waters; (2) contamination of the quality of the waters of the state by waste to a degree which creates a hazard to the public health through poisoning or through the spread of diseases; or (3) nuisance that would be injurious to health, affect an entire community or neighborhood or any considerable number of persons, and occurs during or as a result of the treatment or disposal of wastes. Lastly, construction of the Project would not result in discharges that would cause regulatory impacts within Ballona Creek.

Therefore, the Project's construction impacts on surface water hydrology and quality would be less than significant.

8.3.1.2 Groundwater Hydrology and Quality

Construction of the Project is not anticipated to impact any water supply wells, as no water supply wells are located at or within half a mile downstream of the Project and the Project will not include the construction of any water supply wells. Construction of the Project is not anticipated to impact any water supply wells, as no active water supply wells are located at or within half a mile downstream of the Project and the Project will not include the construction of any water supply wells. Construction of the Project will include excavation depths of approximately 5 to 7 feet bgs in some of the elevated areas. Based on Geotechnical Investigation (included as **Appendix H** to this CE), the historical high groundwater level in the area is 37 feet bgs. Groundwater was encountered during exploration with boring samples explored between 20 feet and 21.5 feet below

grade. Since most of the structure will be above an elevation of 32 feet, it is not expected that groundwater would be encountered during construction that would require temporary or permanent dewatering operations.

In the event perched groundwater is encountered, the Project would be required to obtain a temporary dewatering permit from the City of Los Angeles. If dewatering were to occur on the site, the water quality must first be assessed, and the California State Warning Center (CSWC) should be contacted for assistance. Depending on the quality of water and with the CSWC's assistance, the dewatered water may be managed within this project site, discharged to a sanitary sewer, transported for off-site treatment, used at a separate facility, used on adjacent land, or additional BMPs may be required and the treated water would be discharged into a storm drain or nearing water body. Accordingly, construction of the Project will not adversely impact the rate or direction of flow of groundwater, and the Project potential impacts on groundwater hydrology during construction have been taken into consideration.

Short-term groundwater quality impacts regarding soils and shallow groundwater exposure to construction materials, wastes, and spilled materials will be accounted for and the site will deploy proper housekeeping measures. As previously noted above, construction of the Project will include excavation of approximately 5 to 7 feet bgs. The Project will also result in a net export of existing soil material. There is not a high potential for contaminated soils or groundwater to be encountered, but if contaminated soils are found within the excavation limits, contaminated soils would be collected within the excavated material, removed from the Project Site, and disposed of in accordance with all applicable regulatory requirements.

During on-site grading and building activities, minimal amounts of hazardous materials such as fuels, paints, solvents, and concrete additives could be used, and the presence of such materials provides an opportunity for hazardous materials to be released into groundwater. To protect groundwater resources, the Project will comply with applicable federal, state and local requirements related to the handling, storage, application and disposal of hazardous waste which will reduce the potential for construction activities of the Project to release contaminants into groundwater that could affect existing contamination, mobilize or increase the level of groundwater contamination, or cause a violation of regulatory water quality standards at an existing production well. Therefore, groundwater contamination through hazardous materials releases, and impacts on groundwater quality will be minimized by compliance with applicable regulations.

Therefore, the Project's construction impacts on groundwater hydrology and quality would be less than significant.

8.3.2 Operation

8.3.2.1 Surface Water Hydrology and Quality

Development of the Project would result in an increase in the landscaped areas throughout the Project Site and would increase the impervious surfaces from 99.1 percent to 85.3 percent. This increase in pervious surfaces would result in maintaining in stormwater runoff. Operation of the Project would not result in flooding, impact of the capacity of the existing storm drain system, or worsen an existing flood condition. In addition, the Project would not substantially reduce or

increase the amount of surface water in the local water body or result in a permanent adverse change in the drainage system. As flow are predicted to decrease, it is not anticipated that any deficiencies will be created or exacerbated by the Project on the existing open catch basins and the main 84-inch storm drain line on Vine Street. The capacity of the storm drain facilities, which the Project contributes to, will not be adversely impacted by the proposed change in flows. Therefore, operation of the Project should result in a less than significant effect on surface water hydrology.

The Project will comply with the City's LID Manual,¹¹² which requires that post-construction stormwater runoff from new developments be infiltrated, evapotranspired, captured and reused, and/or treated through a high efficiency BMP onsite for the 85th percentile storm event or 0.75"—whichever is greater. For the Project, the 85th percentile storm event is 0.98". The LID Manual states that BMPs shall be designed to manage and capture stormwater runoff. Infiltration systems are the first priority type of BMP improvements as they provide for percolation and infiltration of the stormwater into the ground, which not only reduces the volume of stormwater runoff entering the MS4 but also contributes to groundwater recharge in some areas.

The second priority BMP is capturing and reusing stormwater onsite for either landscape irrigation or toilet flushing. Projects that cannot infiltrate or harvest/reuse the water quality volume may implement biofiltration BMPs. Biofiltration BMPs shall be sized to adequately capture 1.5 times the volume not managed through infiltration and/or capture and reuse. The project will develop a LID plan to be submitted to the City as part of the final engineering of the project to satisfy water quality requirements of the Project Site. Infiltration will be implemented if feasible, otherwise capture and use will be assessed. If capture/use is infeasible, biotreatment BMPs will be implemented.

The existing Project Site has no known structural or LID BMPs to treat stormwater. Therefore, implementation of the LID features proposed as part of the Project would result in a significant improvement in surface water quality runoff as compared to existing conditions. Implementation of the proposed BMP system will result in the treatment of the entire required volume for the Project Site and the elimination of pollutant runoff up to the 85th percentile storm event.

Based on the proposed LID plan, operation of the Project would not result in discharges that would cause: an incremental increase in pollution which would alter the quality of the waters of the state (Ballona Creek) to a degree which unreasonably affects beneficial uses of the waters; (2) an incremental increase of contamination of the quality of the waters of the state by waste to a degree which creates a hazard to the public health through poisoning or through the spread of diseases; or (3) an incremental increase in the nuisance that would be injurious to health; affect an entire community or neighborhood, or any considerable numbers of persons; and occurs during or as a result of the treatment or disposal of wastes. Lastly, operation of the Project would not result in discharges that would cause regulatory standards to be violated in the Ballona Creek.

Therefore, the Project's operation impacts on surface water hydrology and quality would be less than significant.

¹¹² Planning and Land Development Handbook for Low Impact Development, Part B Planning Activities, 5th Edition; adopted by the City of Los Angeles, Board of Public Works on May 9, 2016.

8.3.2.2 Groundwater Hydrology and Quality

Under the proposed conditions, regional and local potable water levels and adjacent wells or well fields will not be impacted by the Project. The Project does not include any groundwater pumping and relies on the LADWP for water. In addition, the Project is not anticipated to adversely change the rate or direction of flow of groundwater. Implementation of the Project would also result in an increase in pervious areas over the existing conditions. The increase in pervious areas would improve the groundwater recharge capacity of the Project Site over existing conditions. Since the Project is anticipated to implement LID BMPs to treat the required volume of runoff, the Project shall improve the existing groundwater hydrology. The Project's LID BMP design is for capture and reuse, treated runoff is stored within a cistern, and if to be utilized within the 7-month wet season period (October to April). Therefore, operational effects to groundwater hydrology are considered less than significant.

The SWRCB's Geotracker website indicates there are no significant sources of soil or groundwater pollution within the project area. The proposed LID BMP systems are designed to safely convey stormwater runoff into the sub-surface soil without the threat of contaminant mobilization, and will assist in improving the groundwater quality.

Therefore, the Project's operation impacts on groundwater hydrology and quality would be less than significant.

8.4 Conclusion

For all the foregoing reasons, the Project would not have a significant impact related to water quality, and, therefore, the Project would comply with CCR Section 15332(d).

9 Discussion of CCR Section 15332(e)

The site can be adequately served by all required utilities and public services.¹¹³

This section is based on the following items, included as **Appendix G** of this CE:

G-1 Parks Response, Los Angeles Department of Recreation and Parks, September 22, 2022

G-2 Water and Wastewater Technical Report, Fuscoe Engineering, November 29, 2022

9.1 Fire Protection

Within the City of Los Angeles, fire prevention and suppression services and emergency medical services are provided by the Los Angeles Fire Department (LAFD). Project impacts regarding fire protection services are evaluated on a project-by-project basis. A project's land use, fire-related needs, and whether the project site meets the recommended response distance and fire safety requirements, as well as project design features that would reduce or increase the demand for fire protection and emergency medical services, are taken into consideration.

Beyond the standards set forth in the Los Angeles Fire Code, consideration is given to the project size and components, required fire-flow, response distance for engine and truck companies, fire hydrant sizing and placement standards, access, and potential to use or store hazardous materials. The evaluation of the Project's impact on fire protection services considers whether the development of the project would create the need for a new fire station or expansion, relocation, or consolidation of an existing facility to accommodate increased demand, the construction of which would cause significant environmental impacts.

The Project would comply with all applicable regulatory standards. In particular, the Project would comply with LAMC fire safety requirements, including those established in the Building Code (Chapter 9), the Fire Code (Chapter 7) and Section 57.507.3.1 of the LAMC regarding fire flow requirements.

LAMC Chapter V, Article 7, Section 57.512.1 provides that response distances, which are based on land use and fire flow requirements and range from 0.75 mile for an engine company to 2 miles for a truck company, shall comply with Section 57.507.3.3. Where a site's response distance is greater than permitted, all structures must have automatic fire sprinkler systems.

According to LAMC Section 57.512.1,¹¹⁴ response distances based on land use and fire-flow requirements shall comply with Table 57.507.3.3 (recreated below).¹¹⁵

¹¹³ Each of these topic areas (public services [fire, police, schools, parks, libraries] and utilities [wastewater, water, solid waste]) are discussed in their own section.

¹¹⁴ LAMC Section 57,512.1, [http://library.amlegal.com/nxt/gateway.dll/California/lamc/municipalcode/chaptervpublicsafetyandprotection/article7fireprotectionandpreventionfirec?f=templates\\$fn=default.htm\\$3.0\\$vid=amlegal:losangelescamc\\$sanc=JD57.512](http://library.amlegal.com/nxt/gateway.dll/California/lamc/municipalcode/chaptervpublicsafetyandprotection/article7fireprotectionandpreventionfirec?f=templates$fn=default.htm$3.0$vid=amlegal:losangelescamc$sanc=JD57.512).

¹¹⁵ LAMC Table 57,507.3.3, [http://library.amlegal.com/nxt/gateway.dll/California/lamc/municipalcode/chaptervpublicsafetyandprotection/article7fireprotectionandpreventionfirec?f=templates\\$fn=default.htm\\$3.0\\$vid=amlegal:losangelescamc\\$sanc=JD57.507.3.3](http://library.amlegal.com/nxt/gateway.dll/California/lamc/municipalcode/chaptervpublicsafetyandprotection/article7fireprotectionandpreventionfirec?f=templates$fn=default.htm$3.0$vid=amlegal:losangelescamc$sanc=JD57.507.3.3)

This Project would be a high density development. For a high density residential land use, the maximum response distance is 1.5 mile for an engine company and 2 miles for a truck company. The maximum response distances for both fire suppression companies (engine and truck) must be satisfied. According to LAMC Section 57.512.2¹¹⁶, where a response distance is greater than that shown in Table 57.507.3.3 (table recreated below), all structures shall be constructed with automatic fire sprinkler systems. Additional fire protection shall be provided as required by the Fire Chief per LAMC Section 57.512.2.

Table 57.507.3.3
Response Distances That If Exceeded Require The Installation Of An Automatic Fire Sprinklers System

* Land Use	Required Fire-Flow	Maximum Response Distance	
		Engine Co.	Truck Co.
Low Density Residential	2,000 gpm from three adjacent hydrants flowing simultaneously	1-1/2 miles	2 miles
High Density Residential and Commercial Neighborhood	4,000 gpm from four adjacent hydrants flowing simultaneously	1-1/2 miles	2 miles
Industrial and Commercial	6,000 to 9,000 gpm from four hydrants flowing simultaneously	1 mile	1-1/2 miles
High Density Industrial and Commercial or Industrial (Principal Business Districts or Centers)	12,000 gpm available to any block (where local conditions indicate that consideration must be given to simultaneous fires, an additional 2,000 to 8,000 gpm will be required)	3/4 mile	1 mile
gpm – gallons per minute Land use designations are contained in the community plan elements of the General Plan for the City of Los Angeles. The maximum response distances for both L.A.F.D. fire suppression companies (engine and truck) must be satisfied. LAMC Table 57.507.3.3.			

According to the City, the Project Site is first-served by Station No. 27¹¹⁷, located at 1327 Cole Avenue, approximately 0.36 miles driving distance away.

As shown in **Table 9-1**, Fire Station No. 27 has a task force (composed of a truck company and engine company).¹¹⁸ Therefore, the Project Site is located within the maximum distance identified by LAMC Section 57.512.1¹¹⁹ (i.e. within 1.5 mile for an engine and 2 miles for a truck).

¹¹⁶ LAMC Section 57.512.2, [http://library.amlegal.com/nxt/gateway.dll/California/lamc/municipalcode/chaptervpublicsafetyandprotection/article7fireprotectionandpreventionfire?f=templates\\$fn=default.htm\\$3.0\\$vid=amlegal:losangelescamc\\$anc=JD57.512.2](http://library.amlegal.com/nxt/gateway.dll/California/lamc/municipalcode/chaptervpublicsafetyandprotection/article7fireprotectionandpreventionfire?f=templates$fn=default.htm$3.0$vid=amlegal:losangelescamc$anc=JD57.512.2).

¹¹⁷ LAFD, Find Your Station: <https://www.lafd.org/fire-stations/station-results>

¹¹⁸ LAFD: <http://www.lafd.org/about/about-lafd/apparatus>.

¹¹⁹ LAMC Section 57.512.1, [http://library.amlegal.com/nxt/gateway.dll/California/lamc/municipalcode/chaptervpublicsafetyandprotection/article7fireprotectionandpreventionfire?f=templates\\$fn=default.htm\\$3.0\\$vid=amlegal:losangelescamc\\$anc=JD57.512](http://library.amlegal.com/nxt/gateway.dll/California/lamc/municipalcode/chaptervpublicsafetyandprotection/article7fireprotectionandpreventionfire?f=templates$fn=default.htm$3.0$vid=amlegal:losangelescamc$anc=JD57.512).

**Table 9-1
Fire Stations**

No.	Address	Distance	Equipment	Operational Response Time	Incident Counts
27	1327 Cole Avenue	0.36 mile	Task Force Paramedic Ambulance Rescue Ambulance Urban Search/Rescue Battalion Chief	EMS: 6:57 min Non-EMS: 6:11 min	EMS: 5,214 Non-EMS: 1,565
<p>Response Time: (January to September 2022) average time (turnout time + travel time) in the station area. Incident counts: (January to September 2022). Non-EMS is fire emergency. EMS is emergency medical service. http://lafd.org/sites/default/files/pdf_files/11-03-2014_AllStations.pdf Light Force: Truck company and single engine. Task Force: Truck company and two fire engines. LAFD June 2021 Fire Station Directory. Table: CAJA Environmental Services, October 2022.</p>					

The Project Site is in an urbanized area completely surrounded by development. The Project Site is not located in a Very High Fire Hazard Severity Zone¹²⁰ or in the wildlands fire hazard Mountain Fire District.¹²¹

LAMC Section 57.507.3.1 establishes fire water flow standards, which vary from 2,000 gallons per minute (gpm) in low-density residential areas to 12,000 gpm in high-density commercial or industrial areas, with a minimum residual water pressure of 20 pounds per square inch (psi) remaining in the water system. Site-specific fire flow requirements are determined by the LAFD based on land use, life hazard, occupancy, and fire hazard level.

LAMC Section 57.507.3.2 addresses land use-based requirements for fire hydrant spacing and type. Regardless of land use, every first story of a residential, commercial, or industrial building must be within 300 feet of an approved hydrant. The site-specific number and location of hydrants would be determined as part of LAFD's fire/life safety plan review for each development. Final fireflow demands, fire hydrant placement, and other fire protection equipment would be determined for the Project by LAFD during the plan check process. If the Project is determined to require one or more new hydrants during plan check in accordance with city standards, the Project would have to provide them.

The following fire hydrants are near the Project Site:¹²²

- Hydrant (ID 4463, size 2½ x 4D, 8-inch main), southeast corner of Vine Street and Lexington Avenue, south of the Site.

¹²⁰ ZIMAS search: <http://zimas.lacity.org/>.

¹²¹ Los Angeles Safety Element, Exhibit D, Selected Wildfire Hazard Areas in the City of Los Angeles: https://planning.lacity.org/odocument/31b07c9a-7eea-4694-9899-f00265b2dc0d/Safety_Element.pdf, accessed July 19, 2021.

¹²² Navigate LA, DWP (Fire Hydrants) Layer: <http://navigate.la.lacity.org/navigate/la/>

- Hydrant (ID 35764, size 4D, 10-inch main), northwest corner of Vine Street and Lexington Avenue, west of the Site.
- Hydrant (ID 35765, size 2 4D, 10-inch main), southwest corner of Vine Street and La Mirada Avenue, north of the Site.
- Hydrant (ID 42799, size 4D, 6-inch main), southwest corner of Vine Street and La Mirada Avenue, north of the Site.

If the Project is determined to require one or more new hydrants during plan check, the Project would have to provide them.

The existing fire hydrants will be tested to find if adequate for High Density Residential flows, running four (4) simultaneous hydrants with at least 4,000 total gpm. An Information of Fire Flow Availability report (IFFA) is also conducted by LADWP to determine that there is sufficient hydrant flow from existing or proposed hydrants fronting the project based on the existing infrastructure. Additionally, a LADWP Water Pressure application for Fire Service Pressure Flow Report (SAR) is done for the Project to achieve a preliminary analysis of the existing water mains in Vine Street and Lexington Avenue. The results of the SARs determine if the existing mains can convey water supply for both the proposed Project demand and fire services.

The FFAR was received on September 14, 2022. The existing hydrants were tested at 1,500 gpm each, resulting in residual pressures of 90 to 92 pounds per square inches (psi). The surrounding hydrants on Lexington Avenue, La Mirada Avenue, and Vine Street should serve adequate. The hydrants were analyzed with flows of 1,500 gpm each, resulting in residual pressures of 90 – 92 psi. The existing water mains and hydrants surrounding the Project will adequately service the minimum 4,000 gpm from four (4) hydrants running simultaneously.¹²³

In addition to fire hydrant testing, the water main that serves the Site was tested. For a 6-inch pipe, the fire service flow is 1,400 gpm. The Fire Service Pressure Flow report was received on September 16, 2022. The SAR applications confirm that the existing water main in Vine Street was found to be adequate for the proposed required flows of 1,400 gpm having a pressure of 88 psi, however, the existing 4-inch water main in Lexington Avenue would require upsizing to 6-inches to achieve a required flow of 1,400 gpm, if proposing a water connection on Lexington Avenue.

Section 35 of Article XIII of the California Constitution at Subdivision (a)(2) provides: “The protection of public safety is the first responsibility of local government and local officials have an obligation to give priority to the provision of adequate public safety services.” Section 35 of Article XIII of the California Constitution was adopted by the voters in 1993 under Proposition 172. Proposition 172 directed the proceeds of a 0.50-percent sales tax to be expended exclusively on local public safety services. California Government Code Sections 30051-30056 provide rules to implement Proposition 172. Public safety services include fire protection. Section 30056 mandates that cities are not allowed to spend less of their own financial resources on their combined public safety services in any given year compared to the 1992-93 fiscal year. Therefore, an agency is required to use Proposition 172 to supplement its local funds used on fire protection

¹²³ [Water and Wastewater Technical Report](#), Fuscoe Engineering, October 24, 2022, pages 7, 13.

services, as well as other public safety services. In *City of Hayward v. Board of Trustee of California State University* (2015) 242 Cal. App. 4th 833, the court found that Section 35 of Article XIII of the California Constitution requires local agencies to provide public safety services, including fire protection and emergency medical services, and that it is reasonable to conclude that the city will comply with that provision to ensure that public safety services are provided.¹²⁴

For all the foregoing reasons, the Project would be adequately served with respect to fire protection by the LAFD.

9.2 Police Protection

The Project Site is served by the City of Los Angeles Police Department's (LAPD) West Bureau, Hollywood Community Police Station, located at 1358 Wilcox Avenue.¹²⁵ The Community is 17.2 square miles in size, has approximately 300,000 residents, and has approximately 387 sworn officers.¹²⁶ The officer to resident ratio is 1:775.¹²⁷ The Station is approximately 0.25 mile driving distance from the Project Site.

The Project would add approximately 361 residents.¹²⁸ Assuming the same officer to resident ratio, the Project would represent approximately 0.46% of 1 officer.

This increase is negligible and represents less than 1% increase compared to the number of existing officers. The Project will contribute property tax revenue into the City's General Fund, which can be used to fund additional resources per the planning and deployment strategies of the LAPD.

During construction, the open sides on the Project Site would need to be secured to prevent trespass and theft of building materials. The Project Applicant would employ construction security features, such as fencing, which would serve to minimize the need for LAPD services. Temporary construction fencing would be placed along the periphery of the active construction areas to screen as much of the construction activity from view at the local street level and to keep unpermitted persons from entering the construction area.

The potential for crime can be reduced with site-specific designs and features. The Project would include standard security measures such as adequate security lighting, secure access to non-public areas and residential access points. Parking would be in a parking levels integrated into the building. The LAPD will require that the commanding officer of the Station be provided a diagram of each portion of the property showing access routes, and any additional information that might facilitate police response.

Section 35 of Article XIII of the California Constitution at Subdivision (a)(2) provides: "The protection of public safety is the first responsibility of local government and local officials have an

¹²⁴ *City of Hayward v. Board Trustee of California State University* (2015) 242 Cal. App. 4th 833, 847.

¹²⁵ LAPD, Hollywood Station: <https://www.lapdonline.org/lapd-contact/west-bureau/hollywood-community-police-station/>

¹²⁶ https://planning.lacity.org/eir/artisanhollywood/deir/files/App_H.pdf

¹²⁷ $300,000 \text{ persons} / 387 = 775$.

¹²⁸ LADOT population and employee numbers are shown on Table 1:

https://ladot.lacity.org/sites/default/files/documents/vmt_calculator_documentation-2020.05.18.pdf. As shown, multi-family residential is 2.25 persons per unit and affordable housing family is 3.14 persons per unit. $(135 \times 2.25) + (18 \times 3.14) = 361$.

obligation to give priority to the provision of adequate public safety services.” Section 35 of Article XIII of the California Constitution was adopted by voters in 1993 pursuant to Proposition 172. Proposition 172 directed the proceeds of a 0.50-percent sales tax to be expended exclusively on local public safety services. California Government Code Sections 30051-30056 provide rules to implement Proposition 172. Public safety services include fire protection. Section 30056 mandates that cities are not allowed to spend less of their own financial resources on their combined public safety services in any given year compared to the 1992-93 fiscal year. Therefore, an agency is required to use Proposition 172 to supplement its local funds used on fire protection services, as well as other public safety services. In *City of Hayward v. Board of Trustee of California State University* (2015) 242 Cal. App. 4th 833, the court found that Section 35 of Article XIII of the California Constitution requires local agencies to provide public safety services, including police protection, and that it is reasonable to conclude that the city will comply with Proposition 172 to ensure that public safety services are provided.¹²⁹

For all the foregoing reasons, the Project would be adequately served with respect to police protection by the LAPD.

9.3 Schools

The Project is served by the following Los Angeles Unified School District (LAUSD) schools:¹³⁰

- Hollywood Elementary (grades K-5), 1115 Tamarind Avenue
- Joseph Le Conte Middle (grades 6-8), 1316 Bronson Avenue
- Hollywood High (grades 9-12), 1521 Highland Avenue

The residential units directly generate students and the commercial use employees indirectly generate students through their families. As shown in **Table 9-2**, the Project would generate approximately 57 students. This is a conservative amount that does not take credit for the existing uses on the Site.

Table 9-2
Estimated Student Generation

Land Use	Project Amount	Student Generation			
		Elementary	Middle	High	Total
Multi-Family Dwelling Units	153 units	30	8	16	54
Commercial	7,000 sf	1	1	1	3
Total		31	9	17	57

LAUSD Developer Fee Justification Study, March 2022.

Table 3, LAUSD Student Generation Factors: 0.1953 elementary, 0.0538 middle; 0.1071 high school. Table 15, LAUSD Student Generation Factors per 1,000 sf: 0.467 for neighborhood shopping centers; 0.826 students for office.

Since the Study does not specify the grade levels of students that are generated from non-residential land uses, such students are assumed to be divided among the residential generation factors (i.e. approximately 55 percent for elementary, 15 percent for middle, and 30 percent for high school.

¹²⁹ City of Hayward v. Board Trustee of California State University (2015) 242 Cal. App. 4th 833, 847.

¹³⁰ LAUSD School Finder: <https://explorelausd.schoolmint.net/school-finder/home>

Table: CAJA Environmental Services, October 2022.

Pursuant to the California Government Code Section 65995¹³¹ and California Education Code Section 17620¹³², mandatory payment of the school fees established by LAUSD in accordance with existing rules and regulations regarding the calculation and payment of such fees would, by law, fully address and mitigate any potential direct and indirect impacts to schools as a result of the Project. Therefore, Project impacts to school services would be less than significant with compliance with regulatory requirements to pay school fees pursuant to the Government Code.

For all the foregoing reasons, the Project would be adequately served with respect to schools by the LAUSD.

9.4 Parks

The City of Los Angeles Department of Recreation and Parks (LADRP) manages all municipally owned and operated recreation and park facilities within the City. The Public Recreation Plan, a portion of the Service Element of the City's General Plan sets a goal of a parkland acres-to-population ratio of neighborhood and community parks of 4.0 (or 4 acres per 1,000 persons).

Table 9-3 lists the parks and recreation centers that are located near the Project Site.

Table 9-3
Parks and Recreation Centers

Name	Address	Distance to Site
Hollywood Recreation Center	1122 Cole Avenue	750 feet west
Gordon Street Dog Park	1534 Gordon Street	2,900 feet northeast
De Longpre Park	1350 Cherokee Avenue	2,450 feet northwest
NavigateLA with Recreation and Parks Department layer: http://navigatea.lacity.org/index01.cfm		

The Project would increase the number of residents and employees at the Project Site. However, employees do not typically frequent parks or recreation centers during work hours, but are more likely to use facilities near their homes during non-work hours. The Project would include common open space roof deck, and private open space balconies in compliance with the LAMC requirement. While Project residents would use the on-site open spaces and recreational facilities, it is reasonably foreseeable that Project residents would use nearby parks and recreation facilities.

According to the standards provided in the Public Recreation Plan, the 361 net new residents would require 1.44 acres to maintain the standard of four acres per 1,000 people. The City requires developers to dedicate parkland or pay applicable fees (such as dwelling unit construction tax) in lieu of parkland dedication.

¹³¹ California Government Code Section 65995, <https://leginfo.ca.gov/faces/codesdisplaySection.xhtml?lawCode=GOV§ionNum=65995>

¹³² California Education Code Section 17620, <https://leginfo.ca.gov/faces/codesdisplaySection.xhtml?lawCode=EDC§ionNum=17620>

In September 2016, the City adopted a Park Fee Ordinance (Ordinance), which became effective on January 11, 2017. The aim of the Ordinance is to increase the opportunities for park space creation and expand the Quimby fee program beyond those projects requiring a subdivision map to include a park linkage fee for all net new residential units. The Ordinance amends LAMC Sections 12.21, 12.33, 17.03, 17.12 and 17.58, deletes LAMC Sections 17.07 and 19.01, and adds LAMC Section 19.17. The Ordinance increases Quimby fees, provides a new impact fee for non-subdivision projects, eliminates the deferral of park fees for market rate projects that include residential units, increases the fee spending radii from the site from which the fee is collected, provides for early City consultation for subdivision projects or projects with over 50 units in order to identify means to dedicate land for park space, and updates the provisions for credits against park fees.

Thus, the Project would meet the LAMC’s requirement for the provision of usable open space. The Project would be required to pay the in-lieu fee prior to the issuance of a building permit.

While Project residents would use the on-site open spaces and recreational facilities, it is reasonably foreseeable that Project residents would use nearby parks and recreation facilities. However, with the provided on-site and open space and payment of applicable fees, the Project would be adequately served with respect to open space and recreation by area park and recreational facilities.

9.5 Other Public Facilities

The City of Los Angeles Public Library (LAPL) provides library services throughout the City through its Central Library, 8 regional branches, and 64 community branches. The LAPL collection has 7.1 million books, magazines, electronic media, 120 online databases, and 34,000 e-books and related media.¹³³

On February 8, 2007, The Board of Library Commissioners approved a new Branch Facilities Plan. This Plan includes Criteria for new Libraries, which recommends new size standards for the provision of LAPL facilities – 12,500 square feet for communities with less than 45,000 people, 14,500 square feet for community with more than 45,000 people, and up to 20,000 square feet for a Regional branch. It also recommends that when a community reaches a population of 90,000, an additional branch library should be considered for the area.

Table 9-4 describes the libraries that would serve the Project.

Table 9-4
Los Angeles Public Libraries

Name	Address	Size (sf)	Collection Size / Circulation	Service Population	Staff
Durant	7140 Sunset Boulevard	12,500	55,206 / 42,923	93,166	9.5
Hollywood	1623 Ivar Avenue	19,000	76,003 / 36,019	100,283	15
Fremont	6121 Melrose Avenue	7,361	37,072 / 46,770	11,518	9
Staffing is full-time equivalent. Current service is estimated from LA Times Mapping LA database and branch library community boundaries.					

¹³³ LAPL website: <https://www.lapl.org/sites/default/files/media/pdf/about/LAPLFY2017-18Backgrounder10022018.pdf>

Employees do not typically frequent libraries during work hours, but are more likely to use facilities near their homes during non-work hours.

The Project would not directly necessitate the need for a new library facility. This is because the LAPL has indicated that there are no planned improvements to add capacity through expansion. There are no plans for the development of any other new libraries to serve this community. The LAPL uses the most recent Census figures to determine if a branch should be constructed in a given area.

The analysis considers features (on-site library facilities, direct support to LAPL) that would reduce the demand for library services. It is likely that the residents of the Project would have individual access to internet service, which provides information and research capabilities that studies have shown reduce demand at physical library locations.^{134, 135, 136} Further, Measure L has provided funds to restore adequate services to the existing library system. In addition, Project residents could use any of the libraries in the area.

For all of these reasons, it is not anticipated that the Project would result in substantial adverse physical impacts associated with the provision of new or physically altered library facilities, or need for new or physically altered library facilities, the construction of which could cause significant environmental impacts, in order to maintain acceptable service ratios or other performance objectives for library services.

The Hollywood branch would be able to accommodate the Project's 361 residents. Therefore, the Project would be adequately served with respect to library services by the City's libraries.

9.6 Wastewater

The Project Site is located within the service area of the Hyperion Treatment Plant (HTP), which has been designed to treat 450 million gallons per day (mgd) to full secondary treatment. Full secondary treatment prevents virtually all particles suspended in effluent from being discharged into the Pacific Ocean and is consistent with the LARWQCB discharge policies for the Santa Monica Bay. The HTP currently treats an average daily flow of approximately 275 mgd.¹³⁷ Thus, there is approximately 175 mgd available capacity.

As shown on **Table 9-5**, the Project would generate a net total of approximately 53,670 gallons of wastewater per day (or 0.054 mgd). This total does not credit for removal of the existing uses (which are vacant). This total does not take any credit for any proposed sustainable and water conservation features of the Project. This is a worst-case, conservative approach.

¹³⁴ "To Read or Not To Read", see pg. 10: "Literary reading declined significantly in a period of rising Internet use": <https://www.arts.gov/sites/default/files/ToRead.pdf>.

¹³⁵ "How and Why Are Libraries Changing?" Denise A. Troll, Distinguished Fellow, Digital Library Federation: <http://old.diglib.org/use/whitepaper.htm>.

¹³⁶ "Use and Users of Electronic Library Resources: An Overview and Analysis of Recent Research Studies", Carol Tenopir: <http://www.clir.org/pubs/reports/pub120/contents.html>.

¹³⁷ <https://www.lacitysan.org/san/faces/wcnavexternalId/s-lsh-wwd-cw-p-hwrp?adf.ctrlstate=e9g2enwiy5&afrLoop=2223629005130851#!>

**Table 9-5
Project Estimated Wastewater Generation**

Land Use	Size	Rates ¹	Total (gpd)
Proposed Uses			
Residential – Studio	21 units	75 gallons / unit	1,575
Residential – 1-bedroom	89 units	110 gallons / unit	9,790
Residential – 2-bedroom	43 units	150 gallons / unit	6,450
Restaurant	235 seats ²	25 gallons / seat	5,875
Fitness	1,000 sf	650 gallons / 1,000 sf	650
Pool ³	1 pool	29,330 gallons	29,330
Proposed Total			53,670
<p>Note: sf = square feet; gpd = gallons per day ¹ Rates: Los Angeles Bureau of Sanitation, Sewage Generation Factor, effective date April 6, 2012. ² High-turnover Sit-down Restaurant. Assumes 50% of Restaurant Space Will be Usable Seating Area and 15 Square Feet per Seat. ³ The maximum daily pool water use is conservatively assumed to be filled in a single day and is therefore calculated to be the entire volume of the pool, in order to calculate the absolute maximum sewer demands that will be discharged to the public sewer system. <u>Water and Wastewater Technical Report</u>, Fuscoe Engineering, November 29, 2022.</p>			

There are currently four (4) existing sewer mains in the surrounding streets. Two (2) of these mains, a 12-inch and 8-inch, reside in Lexington Avenue and the other two (2), a 10-inch and 33-inch, reside in Vine Street. Beyond the limits of the Project site, the sewer mains on Vine Street continue to flow southerly while the sewer mains on Lexington Avenue flow westerly. Each of these sewer mains that are adjacent to the Project Site connect to a network of sewer lines that ultimately convey wastewater to the City's Hyperion Treatment Plant. Based on available record data from the City, there is currently one existing sewer laterals connecting from the City's public sewer system to the Project Site. The sewer lateral, marked as active, connects to the 8-inch main on Lexington Avenue.

A Sewer Capacity Availability Request (SCAR) was submitted to the Bureau of Sanitation (BOS) to determine whether the existing wastewater infrastructure can accommodate the Project location. Based on the approval of the SCAR, no wastewater service issues have been identified and the Project's wastewater infrastructure would be adequate. The sewer mains in Vine Street and Lexington Avenue will serve the Project, and sewage from the Project Site is conveyed to the City's Hyperion Treatment Plant. The BOS's most current Integrated Resources Plan (IRP) notes that the existing design capacity of the Hyperion Service Area is approximately 550 mgd (consisting of 450 mgd at the Hyperion Treatment Plant, 80 mgd at the Donald C. Tillman Water Reclamation Plant, and 20 mgd at the Los Angeles-Glendale Water Reclamation), and that the existing average daily flow for the system as of 2021 is approximately 275 mgd.

The Project's estimated wastewater generation increase of 0.054 mgd, comprises of less than 0.02 percent of the available capacity in the system and is within the system's remaining capacity of 275 mgd.¹³⁸

¹³⁸ Water and Wastewater Technical Report, Fuscoe Engineering, November 29, 2022.

Based on these forecasts, the Project's increase in wastewater generation would be adequately accommodated by the Hyperion Service Area. In addition, the BOS's analysis confirms that the Hyperion Water Reclamation Plant has sufficient capacity and regulatory allotment for the proposed Project. Thus, operation of the Project would have a less than significant impact on wastewater treatment facilities. Therefore, based on the approved SCAR for the Project and the available wastewater treatment capacity, the Project's wastewater infrastructure would be adequate. Due to this, impacts on wastewater infrastructure would be less than significant.

Therefore, the Project would be adequately served with respect to water treatment by the City's wastewater facilities.

9.7 Water Supply

The City receives water from five major sources: 1) the Eastern Sierra Nevada watershed, via the Los Angeles Aqueduct; 2) the Colorado River, via the Colorado River Aqueduct; 3) the Sacramento- San Joaquin Delta, via the State Water Project and the California Aqueduct; 4) local groundwater; and 5) recycled water. The amount of water obtained from these sources varies from year to year and is primarily dependent on weather conditions and demand. Los Angeles Department of Water and Power (LADWP) has adopted the 2015 Urban Water Management Plan to ensure that existing and projected water demand within its service area can be accommodated. According to the LADWP, for any project that is consistent with the City's General Plan, the projected water demand associated with that project is considered to be accounted for in the 2015 Urban Water Management Plan.

As was shown in the Land Use analysis of this Categorical Exemption, the Project would be consistent with the City's General Plan land use designation for the Project Site. Additionally, the Project Applicant would be required to comply with the water efficiency standards outlined in City Ordinance No. 180822¹³⁹ and in the LAGBC¹⁴⁰ to minimize water usage. Further, prior to issuance of a building permit, the Project Applicant would be required to consult with LADWP to determine Project-specific water supply service needs and all water conservation measures that shall be incorporated into the Project.

The 2020 UWMP was adopted in May 2021 and projects a demand of 642,600 AFY in 2025 (average weather year).¹⁴¹ The UWMP forecasts water demand by estimating baseline water consumption by use (single family, multi-family, commercial/government, industrial), then adjusting for projected changes in socioeconomic variables (including personal income, family size, conservation effects) and projected growth of different uses based on SCAG 2020-2045 RTP/SCS.¹⁴² The 2020-2045 RTP/SCS models local and regional population, housing supply and jobs using a model accounting for job availability by wage and sector and demographic trends (including household size, birth and death rates, migration patterns and life expectancy).¹⁴³

¹³⁹ <http://clkrep.lacity.org/onlinedocs/2009/09-0510ord180822.pdf>

¹⁴⁰ <http://www.ladbs.org/forms-publications/forms/green-building>

¹⁴¹ 2020 Urban Water Management Plan, Los Angeles, Exhibit ES-S.

¹⁴² 2020 Urban Water Management Plan, Los Angeles, page 1-5.

¹⁴³ SCAG, 2020-2045 RTP/SCS, Demographic and Growth Forecast, page 3.

Neither the UWMP forecasts, nor the 2020-2045 RTP/SCS include parcel-level zoning and land use designation as an input. The Project does not materially alter socioeconomic variables or projected growth by use. Any shortfall in LADWP controlled supplies (groundwater, recycled, conservation, LA aqueduct) is offset with MWD purchases to rise to the level of demand. The UWMP demonstrates adequate capacity currently and future capacity to accommodate City growth into which the Project will easily fit.

The LADWP owns and operates the Los Angeles Aqueduct Filtration Plant (LAAFP) located in the Sylmar community of the City. The LAAFP treats City water prior to distribution throughout LADWP’s Central Water Service Area. The designated treatment capacity of the LAAFP is 600 mgd, with an average plant flow of 550 mgd during the summer months and 450 mgd in the non-summer months. Thus, the facility has between approximately 50 to 150 mgd of remaining capacity depending on the season.

As shown on **Table 9-6**, the Project would demand a net total of approximately 53,670 gallons of water per day (or 0.054 mgd). This total does not take credit for removal of the existing uses (which are vacant). This total does not take any credit for any proposed sustainable and water conservation features of the Project. This is a worst-case, conservative approach.

Table 9-6
Project Estimated Water Demand

Land Use	Size	Rates ¹	Total (gpd)
Proposed Uses			
Residential – Studio	21 units	75 gallons / unit	1,575
Residential – 1-bedroom	89 units	110 gallons / unit	9,790
Residential – 2-bedroom	43 units	150 gallons / unit	6,450
Restaurant	235 seats ²	25 gallons / seat	5,875
Fitness	1,000 sf	650 gallons / 1,000 sf	650
Pool ³	1 pool	29,330 gallons	29,330
Proposed Total			53,670
Note: sf = square feet; gpd = gallons per day ¹ Wastewater generation is assumed to equal water consumption. Per the LADWP: “For estimating a project’s indoor water demand, we use applicable sewer generation factors (sgf).” Rates: Los Angeles Bureau of Sanitation, Sewage Generation Factor, effective date April 6, 2012. ² High-turnover Sit-down Restaurant. Assumes 50% of Restaurant Space Will be Usable Seating Area and 15 Square Feet per Seat. ³ The average daily pool water use is calculated using the volume of the pool and dividing that by 365, assuming that the pool is refilled once a year for maintenance. <u>Water and Wastewater Technical Report</u> , Fuscoe Engineering, November 29, 2022.			

With the remaining capacity of approximately 50 to 150 mgd, the LAAFP would have adequate capacity to serve the Project’s projected demand for treatment of 0.054 mgd.

Available record drawings provided by the City show there are current water meters connecting to the 10-inch water main along Vine Street, to the west of the Project Site, and the 4-in water line

on Lexington Avenue. The record drawings indicate the following existing water infrastructure: a 10-inch line on Vine Street, 4-inch line on Lexington Avenue.¹⁴⁴

To determine the ability to provide on-site water service to the Project, a Water Pressure – Flow Report (SAR) was submitted to LADWP to analyze if there is adequate water capacity within both the fire suppression system (i.e. building sprinkler system), and domestic water service. Two locations were analyzed for the capacity to provide water service simultaneously for the onsite domestic water service and fire suppression system. One location was the 10-inch water main on Vine Street and the other was the 4-inch water main on Lexington Avenue.

The SAR analysis received confirmed that there is sufficient water service capacity for the Project demand. Proposed water service can be connected from the existing 10-inch water main in Vine Street that has the capacity for water pipe infrastructure. The expected water demand of the project will require a 6-inch domestic water service and a 6-inch fire water service connection. The location on Lexington Avenue was not able to achieve 1,400 gpm, the maximum flow achieved was 800 gpm at a pressure of 58 psi.

However, per LADWP, the upsizing of the 4-inch pipe to a 6-inch pipe at this location would result in the capacity to achieve flows of 1,400 gpm, if proposing a water connection on Lexington Avenue. The upsizing would allow for there to be adequate water capacity to provide on-site water service to the Project.

Therefore, the Project will plan to connect into the main in Vine Street. The service laterals will be adequately sized to accommodate the on-site fire suppression system demand and domestic demand flowing simultaneously. The new water services will also include backflows and be metered separately per City requirements. Therefore, impacts on water infrastructure would be less than significant.

A Will Serve Letter was also requested to LADWP in order to confirm if the Project demand can be sufficiently supplied. The Will Serve Letter dated August 29, 2022 confirmed that the proposed Project Site can be supplied with water from the municipal system. Therefore, from the Will Serve Letter and SARs, the existing infrastructure can be determined to be adequate to serve the Project.

Therefore, the Project would be adequately served with respect to water supply and treatment by existing LADWP facilities.

9.8 Solid Waste

9.8.1 Environmental Setting

County landfills are categorized as either Class III or unclassified landfills. Non-hazardous municipal solid waste is disposed of in Class III landfills, while inert waste such as construction waste, yard trimmings, and earth-like waste are disposed of in unclassified landfills.¹⁴⁵ Ten Class

¹⁴⁴ [Water and Wastewater Technical Report](#), Fuscoe Engineering, October 4, 2022.

¹⁴⁵ Inert waste is waste which is neither chemically or biologically reactive and will not decompose. Examples of this are sand and concrete.

III landfills and one unclassified landfill with solid waste facility permits are currently operating within the County.¹⁴⁶

Based on the information provided in the 2020 Countywide Integrated Waste Management Plan Annual Report, the remaining disposal capacity for the County’s Class III landfills is estimated at approximately 142.67 million tons.¹⁴⁷

In 2020, approximately 6.019 million tons of solid waste were disposed of at the County’s Class III landfills, 0.244 million tons of inert waste at the County’s inert landfill, and 0.338 million tons at transformation facilities.¹⁴⁸

Of the remaining Class III landfill capacity in the County, approximately 74.13 million tons are available to the City.¹⁴⁹

As is the case with solid waste haulers, landfills operate in a free-enterprise system. Their operating funds and profits are obtained by collecting disposal fees from the haulers on a per ton basis. Landfill capacity is regulated primarily through the amount of solid waste that each particular facility is permitted to collect on a daily basis relative to its capacity.

The 2020 Annual Report indicates that the countywide cumulative need for Class III landfill disposal capacity, approximately 154.1 million tons in 2031, will exceed the 2020 remaining permitted Class III landfill capacity of 142.67 million tons.

The County’s unclassified landfill generally does not currently face capacity issues. The remaining disposal capacity for Azusa Land Reclamation is estimated at approximately 64.64 million tons. In 2020, approximately 0.244 million tons of inert waste (e.g., soil, concrete, asphalt, and other construction and demolition debris) were disposed of at this unclassified landfill. Given the remaining permitted capacity, this capacity would be exhausted in 25 years.¹⁵⁰ Thus, the unclassified landfill serving the County has adequate long-term capacity.

While the City’s Bureau of Sanitation (BOS) generally provides waste collection services to single-family and some small multi-family developments, private haulers permitted by the City provide waste collection services for most multi-family residential and commercial developments within

¹⁴⁶ County of Los Angeles, Department of Public Works; Los Angeles County Integrated Waste Management Plan 2020 Annual Report, October 2021, Appendix E-2 Table 4: <https://dpw.lacounty.gov/epd/swims/News/swims-more-links.aspx?id=4#>, accessed April 21, 2022.

¹⁴⁷ County of Los Angeles, Department of Public Works; Los Angeles County Integrated Waste Management Plan 2020 Annual Report, October 2021, Appendix E-2 Table 4: <https://dpw.lacounty.gov/epd/swims/News/swims-more-links.aspx?id=4#>, accessed April 21, 2022.

¹⁴⁸ County of Los Angeles, Department of Public Works; Los Angeles County Integrated Waste Management Plan 2020 Annual Report, October 2021, Appendix E-2 Table 4: <https://dpw.lacounty.gov/epd/swims/News/swims-more-links.aspx?id=4#>, accessed April 21, 2022.

¹⁴⁹ Total excludes Class III landfills not open to the City of Los Angeles for disposal (i.e., Scholl Canyon, Whittier, Burbank, Pebbly Beach, and San Clemente). In addition, total excludes the Calabasas Landfill, as its watershed does not include the Project Site. The Chiquita Canyon Landfill Expansion permits the facility to operate until it reaches 60 million tons, or after 30 years, whichever comes first. However, since the current volume of the facility’s watershed is unknown, the volume of waste that it would take to reach 60 million tons cannot be determined. As such, for a conservative analysis, the Chiquita Canyon Landfill Expansion is excluded from the total.

¹⁵⁰ County of Los Angeles, Department of Public Works; Los Angeles County Integrated Waste Management Plan 2020 Annual Report, October 2021, Appendix E-2 Table 4: <https://dpw.lacounty.gov/epd/swims/News/swims-more-links.aspx?id=4#>, accessed April 21, 2022.

the City. Solid waste transported by both public and private haulers is either recycled, reused, or transformed at a waste-to-energy facility, or disposed of at a landfill.

In 2018, the City disposed of approximately 3.3 million tons of solid waste at the County’s Class III landfills, approximately 1,968 tons at transformation facilities, and 214 million tons at the inert landfill.¹⁵¹ The 3.3 million tons of solid waste accounts for approximately 4.4 percent of the total remaining capacity (74.13 million tons) for the County’s Class III landfills open to the City.¹⁵²

The landfills that serve the City and the capacity of these landfills are shown on **Table 9-7**. As shown, the landfills have an approximate available daily intake of 11,839 tons.

Table 9-7
Landfill Capacity

Landfill Facility	2020 Average Daily Disposal (tons/day)	Maximum Daily Disposal (tons/day)	Remaining Daily Capacity (tons/day)	Remaining Capacity (million tons)	Remaining Life (years)
Class III Landfills (Open to the City)					
Antelope Valley	2,468	5,548	3,080	10.18	9
Lancaster	402	5,100	4,698	9.87	21
Sunshine Canyon	8,039	12,100	4,061	54.08	17
Total	10,909	22,748	11,839	74	
Inert Landfill (Open to the City)					
Azusa	1,032	8,000	6,968	64.64	25
County of Los Angeles, Department of Public Works; Los Angeles County Integrated Waste Management Plan 2020 Annual Report, October 2021, Appendix E-2 Table 4: https://dpw.lacounty.gov/epd/swims/News/swims-more-links.aspx?id=4# , accessed October 13, 2022.					

9.8.2 Project Impacts

9.8.2.1 Construction

As shown in **Table 9-8**, the Project would result in approximately 3,048 tons of construction and demolition waste, not accounting for any mandatory recycling. For a conservative approach, the modeling included the demolition of the existing building and asphalt.

Pursuant to the requirements of Senate Bill 1374¹⁵³, the Project would implement a construction waste management plan to recycle and/or salvage a minimum of 75 percent of non-hazardous demolition and construction debris. Materials that could be recycled or salvaged include asphalt, glass, and concrete. Debris not recycled could be accepted at the unclassified landfill (Azusa Land Reclamation) within Los Angeles County and within the Class III landfills open to the City.

Given the remaining permitted capacity the Azusa Land Reclamation facility, as well as the remaining capacity at the Class III landfills open to the City, the landfills serving the Project Site

¹⁵¹ These numbers represent waste disposal, not generation, and thus do not reflect the amount of solid waste that was diverted via source reduction and recycling programs within the City

¹⁵² 3.3 million tons ÷ 74.13 million tons x 100% = 4.4%.

¹⁵³ <https://www.calrecycle.ca.gov/lgcentral/library/canddmodel/instruction/sb1374>

would have sufficient capacity to accommodate the Project's construction solid waste disposal needs.

**Table 9-8
Project Estimated Demolition and Construction Waste Generation**

Building	Size	Rate	Total (tons)
Demolition Waste			
Residential	0 sf	127 pounds / sf	0
Non-residential	27,011 sf	158 pounds / sf	2,134
Asphalt	16,000 sf	75 pounds / sf	600
Construction Waste			
Residential	136,295 sf	4.39 pounds / sf	299
Non-residential	7,000 sf	4.34 pounds / sf	15
Total			3,048
Over the entire total schedule of construction. Numbers have been rounded. sf = square feet, 1 ton = 2,000 lbs U.S. Environmental Protection Agency, Report No. EPA530-R-09-002, Estimating 2003 Demolition and Materials Amounts, March 2009, Table 2-1, Table 2-2, Table 2-3, Table 2-4: https://www.epa.gov/smm/estimating-2003-building-related-construction-and-demolition-materials-amounts 1 cubic foot of asphalt weighs 150 pounds. The asphalt at the site is assumed to be 6 inches thick. Table: CAJA Environmental Services, October 2022.			

9.8.2.2 Operation

As shown on **Table 9-9**, the Project would generate a net total of approximately 348 tons per year of solid waste. This total does not take credit for removal of the existing uses (which are vacant).

**Table 9-9
Project Estimated Solid Waste Generation**

Land Use	Size	Rates	Total (Tons per year)
Residential	153 units	2.23 tons / unit	341
Restaurant	7,000 sf	0.91 tons / 1,000 sf	7
Total			348
Note: 1 ton = 2,000 pounds. Los Angeles Unified School District, 2022 Developer Fee Justification Study, March 2022, Table 14. Neighborhood Shopping Center land uses, which is 369 sf per employee. Standard Commercial Office land uses, which is 209 sf per employee. Residential solid waste factor (City of Los Angeles CEQA Thresholds Guide, 2006, page M.3-2) is based on a rate of 12.23 pounds per household per day (or 2.23 tons per household per year). Non-residential yearly solid waste generation factors from City of Los Angeles Bureau of Sanitation, City Waste Characterization and Quantification Study, Table 4, July 2002. https://www2.calrecycle.ca.gov/wastecharacterization/general/rates Table: CAJA Environmental Services, October 2022.			

The estimated solid waste is conservative because the waste generation factors used do not account for recycling or other waste diversion measures such as compliance with Assembly Bill 341, which requires California commercial enterprises and public entities that generate 4 cubic

yards or more per week of waste, and multi-family housing with five or more units, to adopt recycling practices.

Likewise, the analysis does not include implementation of the City's Zero Waste Plan, which is expected to result in a reduction of landfill disposal Citywide with a goal of reaching a Citywide recycling rate of 90 percent by the year 2025, 95% by 2035, and zero waste by 2030.¹⁵⁴

The estimated annual net increase in solid waste that would be generated by the Project represents approximately 0.0004 percent of the remaining capacity for the County's Class III landfills open to the City of Los Angeles.¹⁵⁵

Based on the above, the landfills that serve the Project Site have sufficient permitted capacity to accommodate the solid waste generated by the construction and operation of the Project. Therefore, the Project would be adequately served with respect to solid waste disposal by existing facilities.

9.9 Conclusion

For all the foregoing reasons, the Project and Project Site would be adequately served by all required utilities and public services, and, therefore, the Project would comply with CCR Section 15332(e).

¹⁵⁴ The recycLA program divides the City into 11 zones and designates a waste collection company for each zone. Source: LA Sanitation, recycLA, Your Plan, and City of Los Angeles, L.A.'s Green New Deal, Sustainable City pLAn 2019. <https://plan.lamayor.org/sites/default/files/pLAn2019final.pdf>, accessed August 2, 2021.

¹⁵⁵ $(348 \text{ tons per year} / 74.13 \text{ million tons per year}) \times 100 = \sim 0.0004\%$

10 Guideline 15300.2. Exceptions: (a) Location.

Under CEQA, Categorical Exemption Classes 3, 4, 5, 6, and 11 are qualified by consideration of where the project is to be located – a project that is ordinarily insignificant in its impact on the environment may in a particularly sensitive environment be significant. Therefore, these classes are considered to apply [to] all instances, except where the project may impact on an environmental resource of hazardous or critical concern where designated, precisely mapped, and officially adopted pursuant to law by federal, state, or local agencies.

The Project is seeking a Class 32 Exemption, not a Class 3, 4, 5, 6, or 11 exemption. Therefore, this exception to a categorical exemption for the Project does not apply.

11 Guideline 15300.2. Exceptions: (b) Cumulative Impact.

Under CEQA, all Categorical Exemptions for these classes are inapplicable when the cumulative impact of successive projects of the same type in the same place, over time is significant.

In order to evaluate cumulative impacts of successive projects, the Transportation Assessment identified 30 projects proposed, under construction, or recently built within a 0.5 mile radius (the Related Projects). **Table 11-1** summarizes the land uses for the Related Projects, including:

- 3,912 residential units
- 848 hotel rooms
- 73,695 square feet of retail
- 2,830,872 square feet of office (including event space and sound stages)
- 171,245 square feet of restaurant

All 30 of these Related Projects were evaluated in the Transportation Assessment to evaluate cumulative traffic impacts.

The following six Related Projects are all within 0.25 miles (1,320 feet) of the Project Site and are considered the nearest Related Projects, as shown in **Figure 11-1**:¹⁵⁶

- No. 6, 1310 Cole Avenue, 890 feet northwest of the Project Site. This Project is completed and operational as of October 2022. Therefore, there is no construction overlap.
- No. 9, 1341 Vine Street, 780 feet north of the Project Site. This Project is completed and operational as of October 2022. Therefore, there is no construction overlap.
- No. 18, 1400 Vine Street, 1,100 feet north of the Project Site.
- No. 28, 1235 Vine Street, 100 feet northwest of the Project Site.
- No. 29, 1149 Gower Street, 800 feet east of the Project Site.
- No. 30, 1360 Vine Street, 920 feet north of the Project Site.

The other Related Projects (Nos. 1-5, 7-8, 10-17, 19-27) are more than 0.25 miles from the Project Site and have intervening buildings and major roadways between them and the Project Site. These distances and intervening uses ensure that these project's localized impacts would not be likely to combine with the Project's impacts.

As noted above, two of these nearest Related Projects (Nos. 6 and 9) are already built and would not contribute to cumulative construction-related emissions in the local area. Further, each

¹⁵⁶ Transportation Assessment, Gibson Transportation Consulting, November 2, 2022.

Related Project would be subject to its own CEQA analysis to evaluate potential impacts and provide mitigation measures where appropriate.

Therefore, only the nearest Related Projects (Nos. 18, 28, 29, and 30) were considered for purposes of the noise cumulative construction noise analysis.

**Figure 11-1
Related Projects Map**

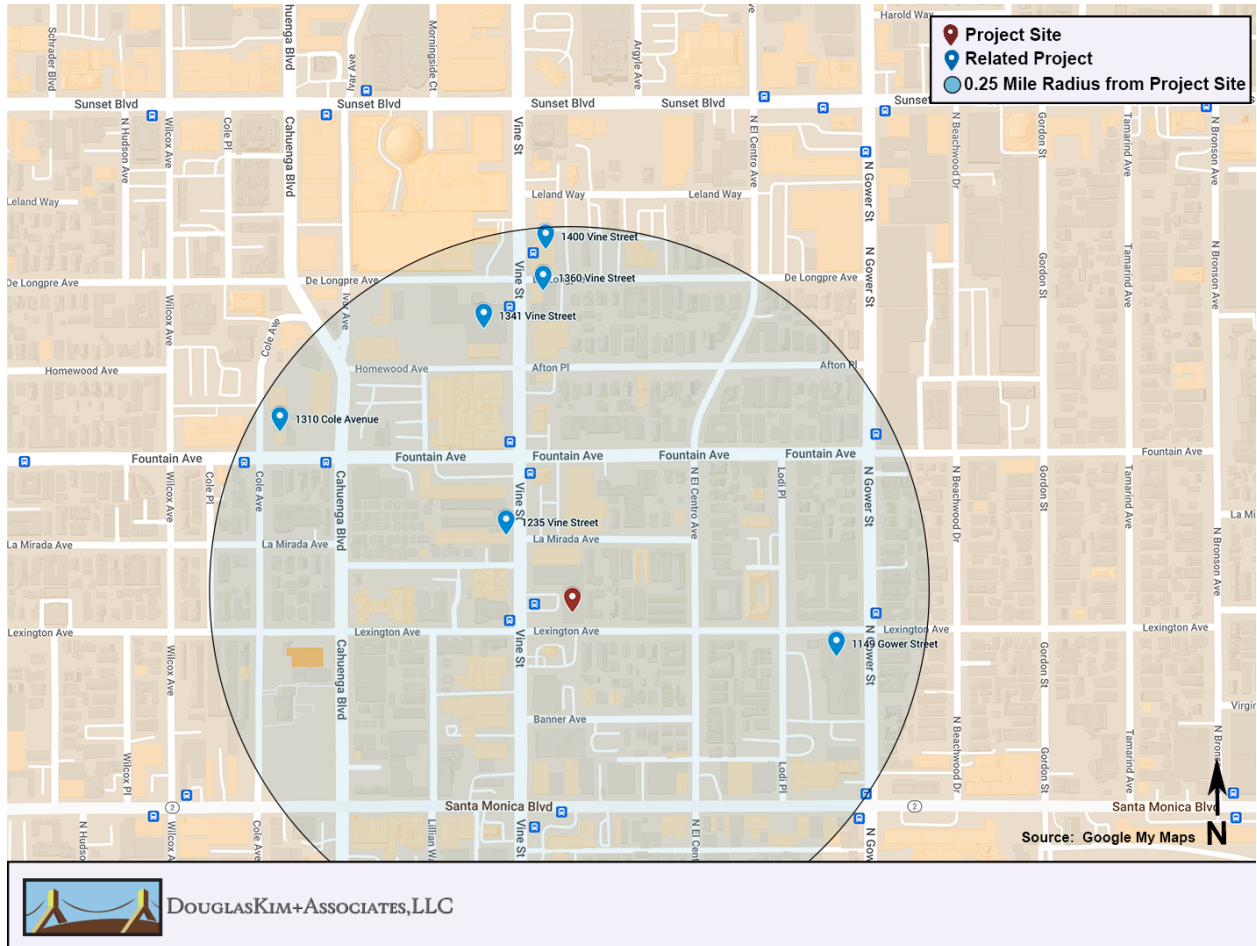

**Table 11-1
Related Projects Land Uses**

#	Address	Use	Quantity
1	956 N Seward St	office	126,980 sf
2	6201 W Sunset Bl	apartment commercial	731 units 24,000 sf
3	6250 W Sunset Bl	apartment retail	200 units 4,700 sf
4	1525 N Cahuenga Bl	hotel restaurant guest lounge restaurant	64 rooms 3,300 sf 1,200 sf 700 sf
5	901 N Vine St	apartment commercial	70 units 3,000 sf
6	1310 N Cole Ave	apartment	369 units

**Table 11-1
Related Projects Land Uses**

		office	2,570 sf
7	6409 W Sunset Bl	hotel retail	275 rooms 1,900 sf
8	6200 W Sunset Bl	apartment retail pharmacy restaurant	270 units 8,070 sf 2,300 sf 1,750 sf
9	1341 Vine St	apartment restaurant/office	200 units 301,854 sf
10	1541 N Wilcox Ave	hotel restaurant restaurant	200 rooms 5,125 sf 4,105 sf
11	1400 N Cahuenga Bl	hotel restaurant bar	220 rooms 2,723 sf 1,440 sf
12	6421 W Selma Ave	hotel restaurant	114 rooms 1,993 sf
13	6400 W Sunset Bl	apartment restaurant	200 units 7,000 sf
14	1546 N Argyle Ave	apartment restaurant retail	276 units 15,000 sf 9,000 sf
15	1545 N Wilcox Ave	event space restaurant	16,100 sf 14,800 sf
16	1438 N Gower St	office sound stage production support restaurant	828,339 sf 205,202 sf 65,319 sf 6,516 sf
17	5939 W Sunset Bl	apartment office restaurant retail	299 units 38,440 sf 3,700 sf 3,970 sf
18	1400 Vine St	Apartment restaurant	198 units 16,000 sf
19	6445 Sunset Bl	hotel restaurant	175 rooms 12,500 sf
20	6422 W Selma Ave	apartment	45 units
21	1520 N Cahuenga Bl	Apartment restaurant	270 units 6,805 sf
22	6450 W Sunset Bl	office restaurant	431,032 sf 12,386 sf
23	1125 N Gower St	apartment	155 units
24	6266 W Sunset Bl	Apartment restaurant	150 units 13,130 sf
25	1000 N Seward St	office restaurant retail	136,200 sf 12,200 sf 2,200 sf
26	6007 W Sunset Bl	apartment retail	110 units 14,555 sf

**Table 11-1
Related Projects Land Uses**

27	6601 W Romaine St	office	106,125 sf
28	1235 Vine St	office restaurant	109,190 sf 7,960 sf
29	1149 N Gower St	apartment	169 units
30	1360 N Vine St	Office restaurant restaurant	463,521 sf 11,914 sf 8,998 sf
Transportation Assessment, Gibson Transportation Consulting, November 2, 2022.			

11.1 Transportation

11.1.1 Plan Consistency

In addition to potential Project-specific impacts, the TAG requires that the Project be reviewed in combination with nearby Related Projects to determine if there may be a cumulatively significant impact resulting from inconsistency with a particular program, plan, policy, or ordinance. In accordance with the TAG, the cumulative analysis must include consideration of any Related Projects within 0.5 miles of the Project Site and any transportation system improvements in the vicinity.

Each of the Related Projects would be separately reviewed and approved by the City, including a check for their consistency with applicable policies. Collectively, the Project and the Related Projects add higher-density development in a high-quality transit area, which would increase pedestrian activity and reduce the need for single occupancy vehicles. Therefore, the Project, together with the Related Projects, would neither create inconsistencies nor result in cumulative impacts with respect to the identified programs, plans, policies, and ordinances.

11.1.2 VMT

The TAG provides that cumulative effects of development projects are determined based on the consistency with the air quality and GHG reduction goals of 2016–2040 Regional Transportation Plan / Sustainable Communities Strategy (Southern California Association of Governments, Adopted April 2016) (RTP/SCS) in terms of development location, density, and intensity. The RTP/SCS presents a long-term vision for the region’s transportation system through Year 2040 and balances the region’s future mobility and housing needs with economic, environmental, and public health goals. The TAG also explains that the RTP/SCS is the regional plan that demonstrates compliance with air quality conformity requirements and GHG reduction targets.

As such, projects that are consistent with this plan in terms of development location, density, and intensity are part of the regional solution for meeting air pollution and GHG goals. Projects that are deemed to be consistent would have a less than significant cumulative impact on VMT. Therefore, based on the conclusions above, the Project would not result in a significant cumulative VMT impact.

Moreover, as previously detailed, the Project is located within a TPA as defined by the City and a High-Quality Transit Area as defined by the RTP/SCS. The Project’s specific location in close

proximity to high-quality transit and other off-site retail, restaurant, commercial, and residential areas, along with its highly walkable environment, support the conclusion that the Project would achieve a VMT reduction greater than the average for the area, as concluded in the Project VMT analysis provided above.

Thus, the Project encourages a variety of transportation options and is consistent with the RTP/SCS goal of maximizing mobility and accessibility in the region. The Project would also contribute to the productivity and use of the regional transportation system by providing housing near transit and encourage active transportation by providing new bicycle parking infrastructure and active street frontages, consistent with RTP/SCS goals. Therefore, the Project would not result in a cumulative VMT impact.

11.1.3 Geometric Design Hazards

The TAG indicates that cumulative impacts for geometric design hazards require a review of Related Projects with access points proposed along the same block(s) as a Project in order to determine the combined impact and the Project's contribution. None of the Related Projects identified provides access along the same block as the Project. Thus, the Project and Related Projects would not result in a cumulative impact.

11.2 Noise

11.2.1 Construction

During construction of the Project, there could be other construction activity in the area that contributes to cumulative noise impacts at sensitive receptors. Noise from construction of development projects is localized and can affect noise-sensitive uses within 500 feet, based on the City's screening criteria. As such, noise from two construction sites within 1,000 feet of each other can contribute to cumulative noise impacts for receptors located between.

There are six related projects (Nos. 6, 9, 18, 28, 29, and 30) identified by the City of Los Angeles within 0.25 miles (1,320 feet) of the Project (**Figure 11-1**, above). As noted above, two of these Related Projects (Nos. 6 and 9) are already built and would not contribute to cumulative impacts in the local area. Therefore, this analysis includes the four remaining nearest Related Projects (Nos. 18, 28, 29, and 30).

As with the Project, any Related Projects would comply with the LAMC's restrictions, including restrictions on construction hours and noise from powered equipment. Noise associated with cumulative construction activities would be reduced to the degree reasonably and technically feasible for each individual Related Project through compliance with the noise ordinance.

As illustrated in **Table 11-2**, the cumulative noise impacts at the analyzed sensitive receptors would not be considered significant, as they would not exceed 5.0 dBA L_{eq} . The noise contours from these Related Project are illustrated in **Figure 11-2**. These cumulative noise levels at analyzed sensitive receptors are marginally higher than impacts from the Project alone, as more distant Related Projects have minimal impact on construction noise levels due to intervening structures that shield noise from more distant construction sites. Based on this, there would not

be cumulative noise impacts at any nearby sensitive uses located near the Project Site and Related Projects in the event of concurrent construction activities.

**Figure 11-2
Construction Noise Contours from Cumulative Development**



**Table 11-2
Cumulative Construction Noise Impacts at Off-Site Sensitive Receptors**

Receptor	Maximum Construction Noise Level (dBA Leq)	Existing Ambient Noise Level (dBA Leq)	New Ambient Noise Level (dBA Leq)	Increase (dBA Leq)	Potentially Significant ?
1. Taglyan Complex	64.3	68.1	69.6	1.5	No
2. Mental Health Center	63.0	68.1	69.3	1.2	No
3. Early Head Start School	58.9	66.7	67.4	0.7	No
4. Residences – 6231-39 Lexington Ave.	61.4	59.5	63.6	4.1	No
5. Hotel – 1133 Vine St.	54.7	66.7	67.0	0.3	No
6. Residences – 6230-40 Lexington Ave.	61.5	59.5	63.6	4.1	No
7. Hotel – 6326 Lexington Ave.	58.6	57.6	61.1	3.5	No
8. Residences – 6232-38 La Mirada Ave.	52.4	59.5	60.3	0.8	No

* Includes Project traffic on local driveway, outdoor mechanical equipment, outdoor noise sources. See Technical Appendix for inventory of sources.
 Source: DKA Planning, 2022.

Other concurrent construction activities from Related Projects can contribute to cumulative off-site impacts if haul trucks, vendor trucks, or worker trips for any Related Projects were to utilize the same roadways. Distributing trips to and from each Related Project construction site substantially reduces the potential that cumulative development could more than double traffic volumes on existing streets, which would be necessary to increase ambient noise levels by 3 dBA. The Project would contribute up to 193 PCE vehicles during a peak, would represent about 7.6 percent of traffic volumes on Vine Street, which carries about 2,552 vehicles at Lexington Avenue in the morning peak hour of traffic.¹⁵⁷

Any Related Projects would have to add 2,359 peak hour PCE vehicle trips to double volumes on Vine Street or any downstream roadways further from the Project Site. The four nearest Related Projects within 1,000 feet of the Project Site would not be capable of generating this much truck traffic, as they would have to average 590 peak hour PCE vehicle trips.

- No. 18, 1400 Vine Street is comparable in scale to the Project, with 198 apartments and 16,000 square feet of restaurants. As such, it is likely to generate a comparable amount of construction-related traffic (i.e., around 200 PCE vehicles in a peak hour).
- No. 28, 1235 Vine Street is comparable in scale to the Project, with 109,190 square feet of office and 7,900 square feet of restaurants (the Project has 136,295 square feet of residential floor area and 7,000 square feet of restaurant). As such, it is likely to generate a comparable amount of construction-related traffic (i.e., around 200 PCE vehicle in a peak hour).
- No. 29, 1149 Gower Street is comparable in scale to the Project, with 169 apartments. As such, it is likely to generate a comparable amount of construction-related traffic (i.e., around 200 PCE vehicle in a peak hour).
- No. 30, 1360 Vine Street is approximately 3.4 times the floor area as the Project (i.e., 463,521 square feet of office and 20,912 square feet of restaurant), it is unlikely to generate substantially more peak-hour PCE trips than the Project, as the construction duration is likely to be longer, thus moderating any peak-hour construction impacts.

As such, cumulative noise due to construction truck traffic from the Project and Related Projects do not have the potential to exceed the ambient noise levels along the haul route by 5 dBA. As such, cumulative off-site noise impacts from construction traffic would be less than significant.

11.2.2 Operation

The Project Site and Hollywood neighborhood has been developed with residential and commercial land uses that have previously generated, and will continue to generate, noise from a number of operational noise sources, including mechanical equipment (e.g., HVAC systems), outdoor activity areas, and vehicle travel. The four nearest Related Projects in the vicinity of the Project Site are residential or mixed-use in nature and would also generate stationary-source and mobile-source noise due to ongoing day-to-day operations. These types of uses generally do not

¹⁵⁷ Gibson Transportation Consulting, Inc. Transportation Assessment for the 1200 Vine Street Project; November 2, 2022.

involve use of noisy heavy-duty equipment such as compressors, diesel-fueled equipment, or other sources typically associated with excessive noise generation.

Noise from on-site mechanical equipment (e.g., HVAC units) and any other human activities from Related Projects would not be typically associated with excessive noise generation that could result in increases of 5 dBA or more in ambient noise levels at sensitive receptors when combined with operational noise from the Project. The presence of intervening multi-story buildings along Vine Street and the residential neighborhoods that flank it will generally shield noise impacts from one or more projects that may generate operational noise. Therefore, cumulative stationary source noise impacts associated with operation of the Project and Related Projects would be less than significant.

The Project would add up to 892 vehicle trips to the local roadway network on a peak weekday at the start of operations in 2027, including up to 95 peak hour P.M. and 97 peak hour A.M. vehicle trips. The four nearest Related Projects within 1,000 feet of the Project Site are projected to generate about 768 additional vehicle trips in the P.M. peak hour.¹⁵⁸ When combined with the Project, these five developments would add up to 863 P.M. peak hour vehicle trips onto local roadways, which would represent 33.8 percent of the 2,552 vehicles currently using Vine Street at Lexington Avenue in the P.M. peak hour.¹⁵⁹ Therefore, cumulative noise impacts due to off-site traffic would not increase ambient noise levels by 3 dBA to or within their respective “Normally Unacceptable” or “Clearly Unacceptable” noise categories, or by 5 dBA or greater overall. Additionally, the Project would not result in an exposure of persons to or a generation of noise levels in excess of standards established in the local general plan or noise ordinance, or applicable standards of other agencies.

11.3 Air Quality

SCAQMD recommends that any construction-related emissions and operational emissions from individual development projects that exceed the project-specific mass daily emissions thresholds identified above also be considered cumulatively considerable.¹⁶⁰ Individual projects that generate emissions not in excess of SCAQMD’s significance thresholds would not contribute considerably to any potential cumulative impact. SCAQMD neither recommends quantified analyses of the emissions generated by a set of cumulative development projects nor provides thresholds of significance to be used to assess the impacts associated with these emissions.

11.3.1 AQMP Consistency

Cumulative development is not expected to result in a significant impact in terms of conflicting with, or obstructing implementation of the 2016 AQMP. As discussed previously, growth considered to be consistent with the AQMP would not interfere with attainment because this growth is included in the projections utilized in the formulation of the AQMP. Consequently, as long as growth in the Basin is within the projections for growth identified in the 2016 RTP/SCS, implementation of the AQMP will not be obstructed by such growth. In addition, as discussed

¹⁵⁸ Gibson Transportation Consulting, Inc. Transportation Assessment for the 1200 Vine Street Project; November 2, 2022.

¹⁵⁹ Gibson Transportation Consulting, Inc. Transportation Assessment for the 1200 Vine Street Project; November 2, 2022.

¹⁶⁰ White Paper on Regulatory Options for Addressing Cumulative Impacts from Air Pollution Emissions, SCAQMD Board Meeting, September 5, 2003, Agenda No. 29, Appendix D, p. D-3.

previously, the population growth resulting from the Project would be consistent with the growth projections of the AQMP. Any Related Project would implement feasible air quality mitigation measures to reduce the criteria air pollutants, if required due to any significant emissions impacts. In addition, each Related Project would be evaluated for its consistency with the land use policies set forth in the AQMP. Therefore, the Project's contribution to the cumulative impact would not be cumulatively considerable and, therefore, would be less than significant.

11.3.2 Construction

SCAQMD recommends that any construction-related emissions and operational emissions from individual development projects that exceed the project-specific mass daily emissions thresholds identified above also be considered cumulatively considerable.¹⁶¹ Individual projects that generate emissions not in excess of SCAQMD's significance thresholds would not contribute considerably to any potential cumulative impact. SCAQMD neither recommends quantified analyses of the emissions generated by a set of cumulative development projects nor provides thresholds of significance to be used to assess the impacts associated with these emissions.

As summarized in **Table 7-6** above, the Project would not exceed the SCAQMD's mass emissions thresholds and would not contribute to any potential cumulative impact. If any Related Projects was projected to exceed LST thresholds (after mitigation), it could perform dispersion modeling to confirm whether health-based air quality standards would be violated. The SCAQMD's LST thresholds recognize the influence of a receptor's proximity, setting mass emissions thresholds for PM₁₀ and PM_{2.5} that generally double with every doubling of distance.

The Project would comply with regulatory requirements, including the SCAQMD Rule 403 requirements listed above. Based on SCAQMD guidance, individual construction projects that exceed the SCAQMD's recommended daily thresholds for project-specific impacts would cause a cumulatively considerable increase in emissions for those pollutants for which the Air Basin is in non-attainment. As shown above, construction-related daily emissions at the Project Site would not exceed any of the SCAQMD's regional or localized significance thresholds. Therefore, the Project's contribution to cumulative air quality impacts would not be cumulatively considerable and, therefore, would be less than significant.

Similar to the Project, the greatest potential for TAC emissions at each Related Projects would generally involve diesel particulate emissions associated with heavy equipment operations during grading and excavation activities. According to SCAQMD methodology, health effects from carcinogenic air toxics are usually described in terms of individual cancer risk. "Individual Cancer Risk" is the likelihood that a person exposed to concentrations of TACs over a 30-year period will contract cancer, based on the use of standard risk-assessment methodology. Construction activities are temporary and short-term events, thus construction activities at each Related Projects would not result in a long-term substantial source of TAC emissions.

Additionally, the SCAQMD CEQA guidance does not require a health risk assessment for short-term construction emissions. It is therefore not meaningful to evaluate long-term cancer impacts from construction activities, which occur over relatively short durations. As such, given the short-

¹⁶¹ White Paper on Regulatory Options for Addressing Cumulative Impacts from Air Pollution Emissions, SCAQMD Board Meeting, September 5, 2003, Agenda No. 29, Appendix D, p. D-3.

term nature of these activities, cumulative toxic emission impacts during construction would be less than significant.

11.3.3 Operation

As discussed above, the Project's operational air quality emissions and cumulative impacts would be less than significant. According to the SCAQMD, if an individual project results in air emissions of criteria pollutants that exceed the SCAQMD's recommended daily thresholds for project-specific impacts, then the project would also result in a cumulatively considerable net increase of these criteria pollutants. As operational emissions would not exceed any of the SCAQMD's regional or localized significance thresholds, the emissions of non-attainment pollutants and precursors generated by Project operations would not be cumulatively considerable.

With respect to TAC emissions, neither the Project nor any likely Related Projects (which are largely residential, retail/commercial in nature), would represent a substantial source of TAC emissions, which are typically associated with large-scale industrial, manufacturing, and transportation hub facilities. The Project and Related Projects would be consistent with the recommended screening level siting distances for TAC sources, as set forth in CARB's Land Use Guidelines, and the Project and Related Projects would not result in a cumulative impact requiring further evaluation.

However, any Related Projects could generate minimal TAC emissions related to the use of consumer products and landscape maintenance activities, among other things. Pursuant to AB 1807, which directs the CARB to identify substances as TACs and adopt airborne toxic control measures to control such substances, the SCAQMD has adopted numerous rules (primarily in Regulation XIV) that specifically address TAC emissions. These SCAQMD rules have resulted in and will continue to result in substantial Basin-wide TAC emissions reductions. As such, cumulative TAC emissions during long-term operations would be less than significant. Therefore, the Project would not result in any substantial sources of TACs that have been identified by the CARB's Land Use Guidelines, and thus, would not contribute to a cumulative impact

11.4 Water Quality

The Project Site and all Related Projects are located in an urbanized area where most of the surrounding properties are already developed. The existing storm drainage system serving this area has been designed to accommodate runoff from an urban built-out environment. When new construction occurs it generally does not lead to substantial additional runoff, since new developments are required to control the amount and quality of stormwater runoff coming from their respective sites.

Additionally, all new development in the City is required to comply with the City's LID Ordinance and incorporate appropriate stormwater pollution control measures into the design plans to ensure that water quality impacts are minimized. Therefore, the cumulative water quality impact of successive projects of the same type in the same place over time would not be significant.

11.5 Public Service

11.5.1 Fire Protection

The Project, in combination with all Related Projects, could increase the demand for fire protection services in the Project area. Specifically, there could be increased demands for additional LAFD staffing, equipment, and facilities over time. This need would be funded via existing mechanisms (e.g., property taxes, government funding, and developer fees) to which the Project and Related Projects would contribute. Similar to the Project, the Related Projects would be subject to the Fire Code and other applicable regulations of the LAMC including, but not limited to, automatic fire sprinkler systems for high-density buildings and/or residential projects located farther than 1.5 miles from the nearest LAFD Engine or Truck Company to compensate for additional response time, and other recommendations made by the LAFD to ensure fire protection safety. Through the process of compliance with existing regulations and LAMC, the ability of the LAFD to provide adequate facilities to accommodate future growth and maintain acceptable levels of service would be ensured. Therefore, the cumulative impact to fire protection from successive projects of the same type in the same place over time would not be significant.

11.5.2 Police Protection

The Project, in combination with all Related Projects, would increase the demand for police protection services in the Project area. Specifically, there would be an increased demand for additional LAPD staffing, equipment, and facilities over time. This need would be funded via existing mechanisms (e.g., sales taxes, government funding, and developer fees), to which the Project and Related Projects would contribute. Similar to the Project, the Related Projects would be subject to the review and oversight of the LAPD related to crime prevention features, and other applicable regulations of the LAMC. Through the process of compliance with existing regulations and LAMC, the ability of the LAPD to provide adequate facilities to accommodate future growth and maintain acceptable levels of service would be ensured. Therefore, the cumulative impact to police protection from successive projects of the same type in the same place over time would not be significant.

11.5.3 Schools

The Project, in combination with all Related Projects, is expected to result in a cumulative increase in the demand for school services. However, similar to the Project, the applicants of all the Related Projects would be required to pay the state mandated applicable school fees to the LAUSD to ensure that no significant impacts to school services would occur. Therefore, the cumulative impact to schools from successive projects of the same type in the same place over time would not be significant.

11.5.4 Parks

The Project, in combination with all Related Projects, could result in an increase in permanent residents residing in the Project area. Additional cumulative development would contribute to lowering the City's existing parkland to population ratio. However, employees generated by the commercial projects and the commercial portions of mixed-use projects on the Related Projects list would not typically enjoy long periods of time during the workday to visit parks and/or recreational facilities. Therefore these project-generated employees would not contribute to the

future demand on park and recreational facility services.

The applicants of Related Projects with residential components would be subject to the City's parkland fees (e.g., Quimby Fees and/or Park and Recreation fees for non-subdivision projects) and to minimum open space requirements, ensuring that any potential impacts to parks and recreational facilities would be less than significant. Therefore, the cumulative impact to parks from successive projects of the same type in the same place over time would not be significant.

11.5.5 Other Public Facilities

Given the geographic range of all Related Projects, they would be served by a variety of libraries.¹⁶² Development of the Related Projects would likely generate additional demands upon library services. However, there are no planned expansions or new libraries by the LAPL that would be considered a significant impact. As such, the demand for library services created by these residential projects could be accommodated, and impacts would be less than significant. Therefore, the cumulative impact to libraries from successive projects of the same type in the same place over time would not be significant.

11.6 Utilities

11.6.1 Wastewater

Implementation of the Project combined with all Related Projects will increase the generation for wastewater treatment, as shown in **Table 11-3**. The remaining treatment capacity of the HTP (175 mgd) will accommodate the wastewater treatment requirements of the Related Projects. The cumulative generation will create the need for 0.63 percent of the remaining capacity of the HTP, and not result in any significant impacts related to sewer treatment.

No new or upgraded treatment facilities will be required to serve the Project, and it is unlikely that any subsequent projects will significantly impact remaining capacity. Therefore, the cumulative wastewater impact from successive projects of the same type in the same place over time will not be significant.

Table 11-3
Project + Related Projects Estimated Wastewater Generation

Land Use	Total Size	Rate	Wastewater (gpd)
Residential	3,912 units	150 gallons / unit	586,800
Retail	73,695 sf	50 gallons / 1,000 sf	3,685
Office	2,830,872 sf	120 gallons / 1,000 sf	339,705
Hotel	848 rooms	120 gallons / room	101,760
Restaurant	171,245 sf	300 gallons / 1,000 sf	51,374
Related Projects Total			1,083,324
Project Total			53,670
Cumulative Total			1,136,994
gpd = gallons per day			
Los Angeles Bureau of Sanitation, Sewage Generation Factor, effective date April 6, 2012.			

¹⁶² LAPL Locations: <http://www.lapl.org/branches>

11.6.2 Water

Implementation of the Project combined with all Related Projects will result in a net increase in water consumption within LADWP's service area, as shown in **Table 11-4**. Similar to the Project, the water supply needs of those Related Projects that are consistent with the City's General Plan have been accounted for in the 2020 UWMP.¹⁶³ However, the applicants of all projects within LADWP's service area will be required to consult with LADWP to determine the specific water supply needs of each respective project, appropriate water conservation measures to minimize water usage, and LADWP's ability to serve each Related Projects.

Larger developments (e.g., residential projects with 500 or more units) will also be required to prepare and obtain approval of a Water Supply Assessment from LADWP.

In addition, the Project will use a small fraction of one percent of the remaining capacity of the LAAFP, and, therefore, will not result in any significant impacts related to water treatment. No new or upgraded treatment facilities will be required to serve the Project, and it is unlikely that any subsequent projects will significantly impact remaining capacity. As such, the cumulative water impact of successive projects of the same type in the same place over time will not be significant.

Table 11-4
Project + Related Projects Estimated Water Demand

Land Use	Total Size	Rate	Water (gpd)
Residential	3,912 units	150 gallons / unit	586,800
Retail	73,695 sf	50 gallons / 1,000 sf	3,685
Office	2,830,872 sf	120 gallons / 1,000 sf	339,705
Hotel	848 rooms	120 gallons / room	101,760
Restaurant	171,245 sf	300 gallons / 1,000 sf	51,374
Related Projects Total			1,083,324
Project Total			53,670
Cumulative Total			1,136,994
gpd = gallons per day			
Los Angeles Bureau of Sanitation, Sewage Generation Factor, effective date April 6, 2012.			

11.6.3 Solid Waste

Implementation of the Project combined with all Related Projects will increase the need for landfill capacity, as shown in **Table 11-5**. All development in the City is required to comply with the City's Curbside Recycling Program and the Construction and Demolition Waste Recycling Ordinance to minimize the amount of solid waste generated and the need for landfill capacity. As discussed previously, the landfills serving the Project area have more than adequate capacity to accommodate the Project. Therefore, cumulative solid waste impact from successive projects of the same type in the same place over time will not be significant.

¹⁶³ LADWP, UWMP, 2020, page II-20: https://www.ladwp.com/ladwp/faces/ladwp/aboutus/a-water/a-w-sourcesofsupply/a-w-sos-uwmpln;jsessionid=0LnVhxdVj2JJg2Vm6Xrr4rmqyLL9GtlpLdJBQxVQgdb53TnwhJRB!-1106340359?_afLoop=151440072116797&_afWindowMode=0&_afWindowId=null#%40%3F_afWindowId%3Dnull%26_afLoop%3D151440072116797%26_afWindowMode%3D0%26_adf.ctrl-state%3Dw319yjmek_4

**Table 11-5
Project + Related Projects Estimated Solid Waste Generation**

Land Use	Total Size	Rate	Solid Waste (tons/yr)
Residential	3,912 units	2.23 tons / unit	8,724
Retail	73,695 sf	0.91 / 1,000 sf	67
Office	2,830,872 sf	1.095 / 1,000 sf	3,100
Hotel	848 rooms	0.73 / room	619
Restaurant	171,245 sf	0.91 / 1,000 sf	156
Related Projects Total			12,666
Project Total			348
Cumulative Total			13,014
1 ton = 2,000 pounds; 1 year = 365 days https://www2.calrecycle.ca.gov/WasteCharacterization/General/Rates			

The Project's contribution to cumulative wastewater, water, and solid waste impacts will not be cumulatively considerable and, therefore, cumulative impacts will be less than significant.

11.7 Conclusion

Therefore, there are no cumulative significant impacts, and this exception does not apply to the Project.

12 Guideline 15300.2. Exceptions: (c) Significant Effect.

A categorical exemption shall not be used for an activity where there is a reasonable possibility that the activity will have a significant effect on the environment due to unusual circumstances.

This section is based on the following items, included as **Appendix H** of this CE:

H-1 Geotechnical Engineering Investigation, Geotechnologies, Inc., December 9, 2021

H-2 Approval Letter, Los Angeles Department of Building and Safety, July 29, 2022

12.1 Introduction

The Project would not have a significant effect on the environment and there are no unusual circumstances associated with the Project, the Project Site, or the vicinity. The Project Site is in an area that is highly urbanized, currently fully developed with commercial buildings and parking area, and flat. There are no unusual circumstances related to the development of the Project's uses at this location. The Project will be required to comply with all applicable regulatory measures.

The overall mass and scale of the building is compatible with the surrounding built environment. The traditional land use pattern of this section of Vine Street and Lexington Avenue include a mix of commercial uses such as retail strip malls, individual businesses, and some multi-story residential buildings. There are numerous multi-story buildings in the area ranging from two to eight stories. The newly constructed Jardin Residential Building located at 6390 De Longpre Avenue reaches 20 stories, and is complemented by other high-rise construction throughout this Hollywood neighborhood, including the 7-story residential building (Rise Hollywood, 1331 Cahuenga Boulevard) and 5-story office building (Netflix on Vine, 1341 Vine Street). The Project fits in with the context of neighboring buildings and with the pattern of new and proposed construction throughout Hollywood.

12.2 Unusual Circumstances

The Project proposes an infill development that is consistent with the existing zoning, General Plan land use designation, and all objectives of the Community Plan.

The Project Site is not located in a designated significant ecological area¹⁶⁴ or other overlay that would denote special circumstances.

12.3 Methane

The Site is not within a Methane Zone.¹⁶⁵

¹⁶⁴ NavigateLA, Special Areas layer: <https://navigatea.lacity.org/navigatea/>

¹⁶⁵ <http://zimas.lacity.org>, accessed October 13, 2022.

12.4 Oil and Gas Fields

The Site is not within the limits of the LA City oil field.¹⁶⁶ The closest mapped oil well is the Salt Lake Oil Field approximately 3,300 feet south of the Site.¹⁶⁷ According to a review of the California Department of Geological Energy Management (CalGEM) map, the nearest oil well is identified as API 0403720765, and located 725 feet northeast of the Site at 6220 Afton Place.¹⁶⁸

12.5 Geotechnical Considerations

According to the California Department of Conservation, the Project Site is:¹⁶⁹

- not within an earthquake fault zone
- not within a liquefaction zone
- not within a landslide zone

Further, the State of California Seismic Hazard Zone Map for the Hollywood Quadrangle indicates that the Site is not located within an area identified as having a potential for liquefaction. Also, according to the Los Angeles Safety Element, the Site is not located within an area identified as having a potential for liquefaction.

As a conservative measure, the Geotechnical Engineering Investigation conducted a site-specific liquefaction analysis. The site-specific liquefaction analysis, indicates that the site soils would not be prone to liquefaction during the ground motion expected during the design-based seismic event.¹⁷⁰

The Project will comply with design criteria provided in the Geotechnical Engineering Investigation including the Uniform Building Code Section 1804.5 (Liquefaction Potential and Soil Strength Loss). The Project will be completed in accordance with the provisions of the most current applicable building code and requirements of the LADBS. The Geotechnical Engineering Investigation was reviewed and approved by LADBS.¹⁷¹

12.6 Conclusion

There are no unusual circumstances that may result in any significant environmental effects, and this exception does not apply to the Project.

¹⁶⁶ Geotechnical, Oil/Gas Fields layer, <https://navigatela.lacity.org/navigatela/>, accessed October 13, 2022.

¹⁶⁷ California Department of Conservation Wellfinder map: <https://maps.conservation.ca.gov/doggr/wellfinder/#openModal/-118.35524/34.02773/14>, accessed October 13, 2022.

¹⁶⁸ California Department of Conservation Wellfinder map: <https://maps.conservation.ca.gov/doggr/wellfinder/#openModal/-118.36887/34.16208/15>, accessed October 13, 2022.

¹⁶⁹ California Department of Conservation: <https://maps.conservation.ca.gov/cgs/EQZApp/>, accessed October 13, 2022.

¹⁷⁰ Geotechnical Engineering Investigation, Geotechnologies, Inc., December 9, 2021.

¹⁷¹ Approval Letter, Los Angeles Department of Building and Safety, July 29, 2022.

13 Guideline 15300.2. Exceptions: (d) Scenic Highways.

A categorical exemption shall not be used for a project which may result in damage to scenic resources, including but not limited to, trees, historic buildings, rock outcroppings, or similar resources, within a highway officially designated as a state scenic highway. This does not apply to improvements which are required as mitigation by an adopted negative declaration or certified EIR.

This exception applies only to projects within a designated state scenic highway. The closest officially designated state scenic highways are:¹⁷²

- State Route 27, Topanga Canyon Boulevard, from Mulholland Highway to Pacific Coast Highway. This is 15 miles west of the Site.
- State Route 2, Angeles Crest Highway, from 3 miles north of I-210 in La Canada to the San Bernardino County Line. This is 12 miles northeast of the Site.

The Project Site is not located within or along a designated scenic highway, corridor, or parkway.¹⁷³ Vine Street is not designated scenic highways in the area around the Project Site.¹⁷⁴

Therefore, the Project would not damage a scenic resource within a scenic highway, and this exception does not apply to the Project.

¹⁷² Caltrans State Scenic Highways Map: <https://caltrans.maps.arcgis.com/apps/webappviewer/index.html?id=465dfd3d807c46cc8e8057116f1aaca>, accessed October 13, 2022.

¹⁷³ California Scenic Highway Mapping Systems: <http://www.dot.ca.gov/hq/LandArch/scenichighways/index.htm>

¹⁷⁴ Mobility Element 2035: https://planning.lacity.org/odocument/523f2a95-9d72-41d7-aba5-1972f84c1d36/Mobility_Plan_2035.pdf

14 Guideline 15300.2. Exceptions: (e) Hazardous Waste Sites.

A categorical exemption shall not be used for a project located on a site which is included on any list compiled pursuant to section 65962.5 of the government code.

14.1 Cortese List

In meeting the provisions in Government Code Section 65962.5, commonly referred to as the “Cortese List,” database resources that provide information regarding identified facilities or sites include EnviroStor, GeoTracker, and other lists compiled by the California Environmental Protection Agency.

According to EnviroStor, there are no cleanup sites, permitted sites, or SLICS (Spills, Leaks, Investigation, and Cleanup) on the Project Site.¹⁷⁵

According to GeoTracker, there are no other cleanup sites, land disposal sites, military sites WDR sites, permitted UST (Underground Storage Tanks) facilities, monitoring wells, or California Department of Toxic Substance Control (DTSC) cleanup sites or hazardous materials permits on the Project Site.¹⁷⁶

The Project Site has not been identified as a solid waste disposal site having hazardous waste levels outside of the Waste Management Unit.¹⁷⁷

There are no active Cease and Desist Orders or Cleanup and Abatement Orders from the California Water Resources Control Board associated with the Project Site.¹⁷⁸

The Project Site is not subject to corrective action pursuant to the Health and Safety Code, as it has not been identified as a hazardous waste facility.¹⁷⁹

14.2 Conclusion

The Project would not create a hazard to the public or the environment as a result of being listed on a list of hazardous materials sites compiled pursuant to Government Code Section 65962.5. Therefore, this exemption does not apply to the Project.

¹⁷⁵ California Department of Toxic Substance Control, EnviroStor, website: <http://www.envirostor.dtsc.ca.gov/public/>.

¹⁷⁶ California State Water Resources Control Board, GeoTracker, website: <http://geotracker.waterboards.ca.gov/map>.

¹⁷⁷ California Environmental Protection Agency, Cortese List Data Resources, Sites Identified with Waste Constituents Above Hazardous Waste Levels Outside the Waste Management Unit, website: <https://calepa.ca.gov/wp-content/uploads/sites/6/2016/10/SiteCleanup-CorteseList-CurrentList.pdf>

¹⁷⁸ California Environmental Protection Agency, Cortese List Data Resources, List of “Active” CDO and CAO from Water Board, website: <http://www.calepa.ca.gov/sitecleanup/corteselist/>.

¹⁷⁹ California Environmental Protection Agency, Cortese List Data Resources, Cortese List: Section 65962.5(a), website: <https://calepa.ca.gov/sitecleanup/corteselist/section-65962-5a/>

15 Guideline 15300.2. Exceptions: (f) Historical Resources.

A categorical exemption shall not be used for a project which may cause a substantial adverse change in the significance of a historical resource.

15.1 Existing Setting

The Site is not subject to a Historic Preservation Review,¹⁸⁰ not listed in HistoricPlacesLA,¹⁸¹ and not listed in SurveyLA.¹⁸²

15.2 Conclusion

The Project Site has not been listed or eligible for listing in the California Register, or in a local register of historical resources as defined in Public Resources Code Section 5020.1(k).

Therefore, this exception does not apply to the Project.

¹⁸⁰ <http://zimas.lacity.org>, accessed October 13, 2022.

¹⁸¹ The Los Angeles Historic Resources Inventory website, HistoricPlacesLA.org, is managed and maintained by the Los Angeles Office of Historic Resources (OHR). It includes properties designated as Los Angeles Historic-Cultural Monuments (HCM) or located within designated Historic Preservation Overlay Zones (HPOZ). <http://historicplacesla.org/map>, accessed October 13, 2022.

¹⁸² The findings of SurveyLA, the citywide historic resource survey of Los Angeles, are also included in HistoricPlacesLA.org as well as individual survey reports for each Community Plan Area (CPA). SurveyLA, Hollywood: <https://planning.lacity.org/preservation-design/survey-la-results-hollywood>, accessed October 13, 2022.



1200 VINE ST

CONCEPTUAL DESIGN PACKAGE

CONTENTS

A0-0	TITLE SHEET
A0-3	PROJECT DATA
A0-4	SITE SURVEY
A1-0	SITE PLAN
A1-2	OPEN SPACE EXHIBIT
A1-3	FAR CALCULATION
A3-0	BUILDING PLANS
A4-0	BUILDING SECTIONS
A5-0	UNIT PLANS
A6-0	CONCEPTUAL PERSPECTIVES

PROJECT LOCATION

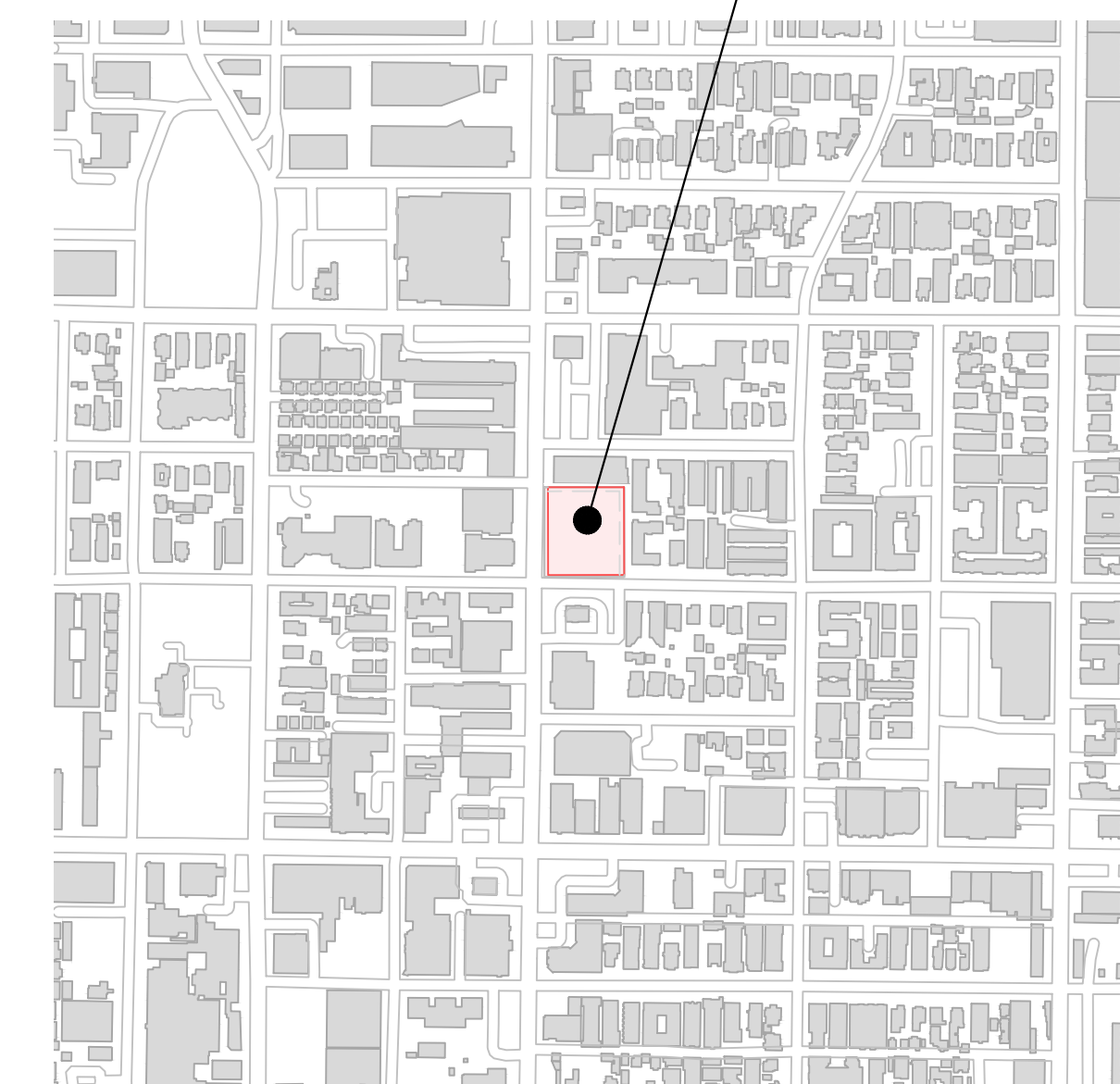

VICINITY MAP NTS



Architecture + Planning
888.456.5849
ktgy.com

Grubb
4601 Park Road, Suite 450
Charlotte, NC 28209

1200 VINE STREET
LOS ANGELES, CA # 2021-1034

CONCEPTUAL DESIGN
JULY 26, 2022

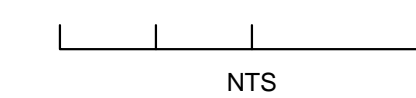

TITLE SHEET
TABLE OF CONTENTS

A0-0

PROJECT ZONING	
PROJECT NAME	1200 VINE ST
PROJECT ADDRESS	1200-1218 N. VINE ST 6245-6247 W. LEXINGTON AVE. Los Angeles, CA 90027
LAND USE	Highway Oriented Commercial
ASSESSOR PARCEL #	5534-002-023 & 18
ZONING	[Q] C2-2D-CPIO
COMMUNITY PLAN	HOLLYWOOD COMMUNITY PLAN - CPIO
LEGAL DESCRIPTION	Refer to the Site Survey on sheet A0-4: "THE LAND REFERRED TO HEREIN BELOW IS SITUATED IN THE CITY OF LOS ANGELES, IN THE COUNTY OF LOS ANGELES, STATE OF CALIFORNIA, AND IS DESCRIBED AS FOLLOWS: PARCEL 1: THAT PORTION OF BLOCK 12 OF COLEGROVE, IN THE CITY OF LOS ANGELES, COUNTY OF LOS ANGELES, STATE OF CALIFORNIA, AS PER MAP RECORDED IN BOOK 53 PAGE 10 OF MISCELLANEOUS RECORDS, IN THE OFFICE OF COUITY RECORDER OF SAID COUNTY. DESCRIBED AS FOLLOWS: BEGINNING AT THE INTERSECTION OF THE NORTH LINE OF LEXINGTON AVENUE (FORMERLY EMILTA AVENUE) WITH THE EAST LINE OF VINE STREET; THENCE NORTHERLY ALONG SAID EASE LINE OF VINE STREET 150 FEET; THENCE EAST PARALLEL WITH SAID NORTH LINE OF LEXINGTON AVENUE 198 FEET; THENCE SOUTHERLY PARALLEL WITH SAID EAST LINE OF VINE STREET 150 FEET TO THE NORTH LINE OF SAID LEXINGTON AVENUE; THENCE WESTERLY ALONG SAID NORTHERLY LINE TO THE POINT OF BEGINNING. PARCEL 2: THAT PORTION OF BLOCK 12 OF COLEGROVE, IN THE CITY OF LOS ANGELES, COUNTY OF LOS ANGELES, STATE OF CALIFORNIA, AS PER MAP RECORDED IN BOOK 53 PAGE 10 OF MISCELLANEOUS RECORDS OF SAID COUNTY. DESCRIBED AS PARCELS NO. 2 AND NO. 3 IN DEED TO CITY OF LOS ANGELES RECORDED IN BOOK 7822, PAGE44 OF OFFICIAL RECORDS, IN THE OFFICE OF THE COUNTY RECORDER OF SAID COUNTY.
COMBINED SITE AREA	40,786 0.936 AC
SETBACKS	
	REQUIRED PROPOSED
FRONT (Lexington)	com. 0' _ Res. 0' com. 0' _ Res. 0'
SIDE (Vine)	com. 0' _ Res. 0' com. 0' _ Res. 0'
SIDE (Abutting Prop.)	com. 0' _ Res. 11' com. 0' _ Res. 11'
REAR (Abutting Prop.)	com. 0' _ Res. 20' com. 0' _ Res. 10'

PROJECT SUMMARY & DATA			
LOT AREA	40,786 SF	0.936 AC	
DENSITY			
C2-1D ZONE (BASE) 1/400SF 102 UNITS	[Q] C2-2D-CPIO 1/275SF 148 UNITS	DB AB-2345 50% INCREASE 153 UNITS 17% VLI UNITS - 18 UNITS	
PROPOSED DENSITY	163.4 DU/AC		
FAR			
PROPOSED FAR	143,295 SF	3.51 :1	
PROGRAM	RETAIL	7,000 SF	
	LEASING	2,160 SF	
	FITNESS	1,000 SF	
	CLUB ROOMS	1,735 SF	
	RESIDENTIAL NRSF	104,533 SF	
PROPOSED MIX			
STUDIO	21 UNITS	14%	AVE. 435 SF
1-BED	89 UNITS	58%	AVE. 580 SF
2-BED	43 UNITS	28%	AVE. 1,018 SF
TOTAL	153 UNITS	100%	AVE. 683 SF
HEIGHT			
PERMITTED	UNLIMITED		
PROPOSED	88'-6" _ 8 STORIES		
PARKING			
REQUIRED	92 SPACES		
PROPOSED	93 SPACES		
OPEN SPACE			
REQUIRED	16,375 SF		
PROPOSED	21,569 SF		

FAR TABLE		
LOT SIZE: 40,786 SQFT		
	FAR	SQFT PERMITTED
C2-1D ZONE	.5 :1	20,393 SF
[Q]C2-2D-CPIO (BASE)	1.5 :1	61,179 SF
[Q]C2-2D-CPIO (BONUS)	3.0 :1	122,358 SF
PROPOSED	3.5 :1	143,295 SF

PARKING						
REQUIRED PARKING	RESIDENTIAL					
	UNIT COUNT		AB 2345		Included in the total count	
STUDIO UNITS	21	13.7%	0.5 PER UNIT	11	ADA REQ'D	EV READY
ONE BEDROOM UNITS	89	58.2%	0.5 PER UNIT	45	2% of total standrad stalls + 2% of EV Ready stalls	30% of total, inc. 10% EVCS
TWO BEDROOM UNITS	43	28.1%	0.5 PER UNIT	22		
	153 UNITS		TOTAL	78 SPACES	3 SPACES	24 SPACES
REQUIRED PARKING COMMERCIAL						
GROUND FLOOR RETAIL	7,000 SF	2 PER 1,000 SF	14 SPACES		2 SPACES	5 SPACES
TOTAL			AB 2345:	92 SPACES	5 SPACES	29 SPACES

PARKING						
PROVIDED PARKING	RESIDENTIAL					
	COMPACT	STANDARD	EV READY	EV READY ADA	ADA	TOTAL
1st FLOOR	3	3	19	0	1	26
2nd FLOOR	6	39	5	1	1	52
TOTAL OF EACH STALL TYPE	9	42	24	1	2	
TOTAL PROVIDED	78 SPACES					0.51 SPACE/UNIT

PROVIDED PARKING	COMMERCIAL					
	COMPACT	STANDARD	EV READY	EV READY ADA	ADA	TOTAL
1st FLOOR	3	7	3	1	1	15
2nd FLOOR	0	0	0	0	0	0
TOTAL OF EACH STALL TYPE	3	7	3	1	1	
TOTAL PROVIDED	15 SPACES					1 SPACE / 400 SF

OPEN SPACE			
REQUIRED	OPEN SPACE PER R4 ZONE		
STUDIO UNITS	21	100 PER UNIT	2,100
ONE BEDROOM UNITS	89	100 PER UNIT	8,900
TWO BEDROOM UNITS	43	125 PER UNIT	5,375
	153 UNITS	REQUIRED OPEN SPACE	16,375 SF

PROVIDED	OPEN SPACE
PRIVATE DECKS (50sf max.)	7,650 SF
OUTDOOR OPEN SPACE - L1	1,700 SF
CO-WORK DECK - L2	NA
PODIUM COURTYARD - L3	6,255 SF
ROOF DECK A - L8	870 SF
ROOF DECK B - L8	1,000 SF
INDOOR AMENITIES (max. 25% of total req.)	4,094 SF
TOTAL	21,569 SF

BIKE PARKING			
LONG-TERM			
DWELLING UNITS	RATIO	DU	TOTAL
1-25 DU	1	25	25.0
26-100 DU	0.67	75	50.0
101-200 DU	0.5	53	26.5
COMMERCIAL	RATIO / SQFT	SQFT	TOTAL
	2000	7000	3.5
TOTAL REQUIRED			105.0
TOTAL PROPOSED			106
SHORT-TERM			
DWELLING UNITS	RATIO	DU	TOTAL
1-25 DU	0.10	25	2.5
26-100 DU	0.07	75	5.0
101-200 DU	0.05	53	2.7
COMMERCIAL	RATIO / SQFT	SQFT	TOTAL
	2000	7000	3.5
TOTAL REQUIRED			13.7
TOTAL PROPOSED			14

INCENTIVES				
	BASE ZONING (C2-1D ZONE)	HOLLYWOOD CPU [Q] C2-2D-CPIO CORRIDOR 2 SUBAREA	DENSITY BONUS AB 2345	PROVIDED
FAR	0.5:1 20,393 SF	1.5:1 61,179 SF	3.0:1 122,358 SF	3.5:1 143,295 SF
SETBACKS	FRONT: COM. 0' _ RES. 0' SIDE: COM. 0' _ RES. 0' SIDE: COM. 0' _ RES. 11' REAR: COM. 0' _ RES. 20'	FRONT: COM. 0' _ RES. 0' SIDE: COM. 0' _ RES. 0' SIDE: COM. 0' _ RES. 5' REAR: COM. 0' _ RES. 5'	FRONT: COM. 0' _ RES. 0' SIDE: COM. 0' _ RES. 0' SIDE: COM. 0' _ RES. 11' REAR: COM. 0' _ RES. 20'	FRONT: COM. 0' _ RES. 0' SIDE: COM. 0' _ RES. 0' SIDE: COM. 0' _ RES. 11' REAR: COM. 0' _ RES. 10' (50% REDUSTION IN THE REAR SETBACK)



Architecture + Planning
888.456.5849
ktgy.com

Grubb
4601 Park Road, Suite 450
Charlotte, NC 28209

1200 VINE STREET
LOS ANGELES, CA # 2021-1034

CONCEPTUAL DESIGN
JULY 26, 2022

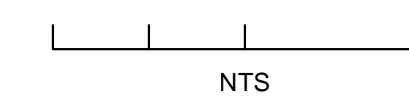

PROJECT DATA

A0-3

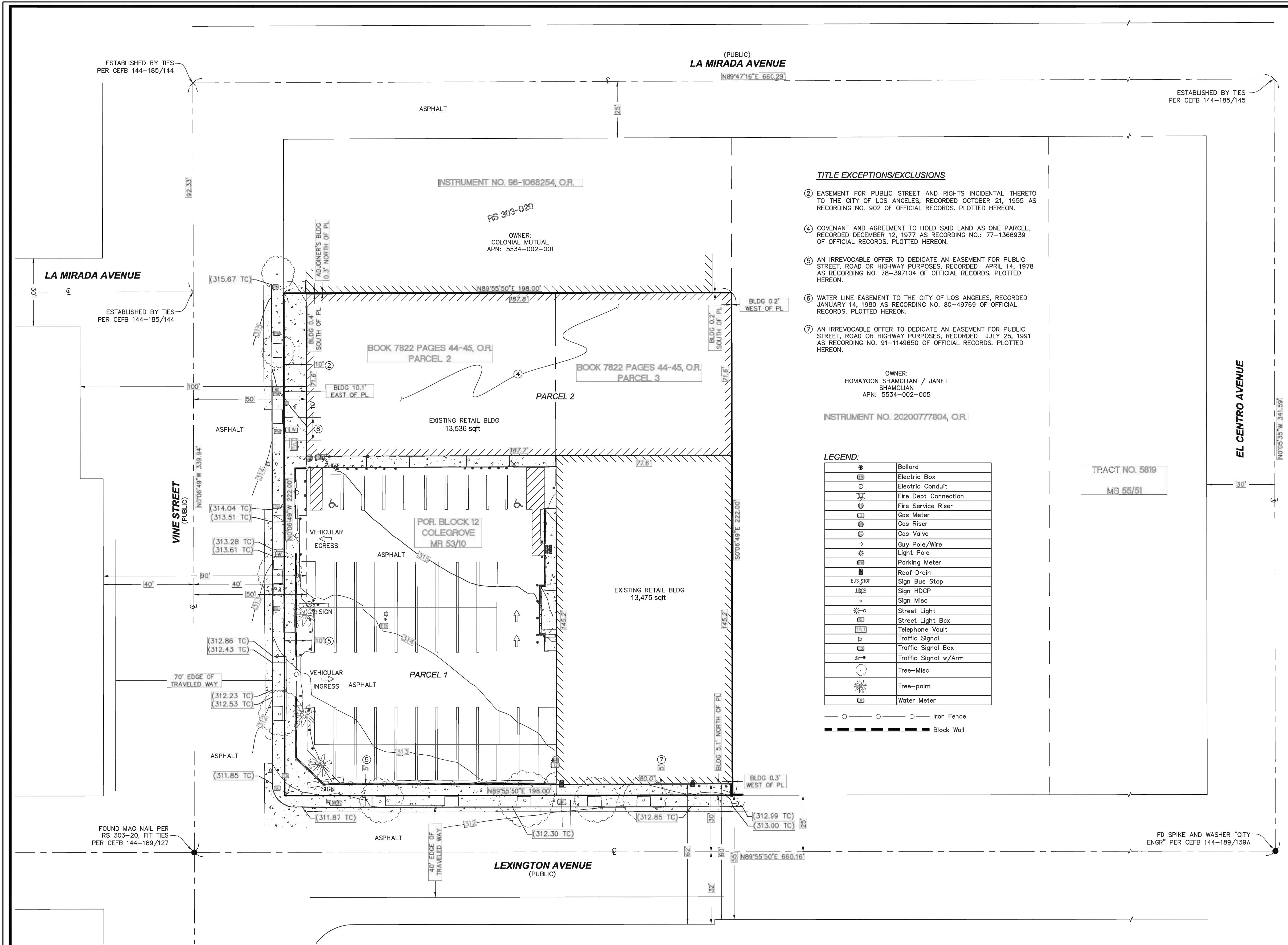

- TITLE EXCEPTIONS/EXCLUSIONS**
- EASEMENT FOR PUBLIC STREET AND RIGHTS INCIDENTAL THERETO TO THE CITY OF LOS ANGELES, RECORDED OCTOBER 21, 1955 AS RECORDING NO. 902 OF OFFICIAL RECORDS. PLOTTED HEREON.
 - COVENANT AND AGREEMENT TO HOLD SAID LAND AS ONE PARCEL, RECORDED DECEMBER 12, 1977 AS RECORDING NO.: 77-1366939 OF OFFICIAL RECORDS, PLOTTED HEREON.
 - AN IRREVOCABLE OFFER TO DEDICATE AN EASEMENT FOR PUBLIC STREET, ROAD OR HIGHWAY PURPOSES, RECORDED APRIL 14, 1978 AS RECORDING NO. 78-397104 OF OFFICIAL RECORDS. PLOTTED HEREON.
 - WATER LINE EASEMENT TO THE CITY OF LOS ANGELES, RECORDED JANUARY 14, 1980 AS RECORDING NO. 80-49769 OF OFFICIAL RECORDS. PLOTTED HEREON.
 - AN IRREVOCABLE OFFER TO DEDICATE AN EASEMENT FOR PUBLIC STREET, ROAD OR HIGHWAY PURPOSES, RECORDED JULY 25, 1991 AS RECORDING NO. 91-1149650 OF OFFICIAL RECORDS. PLOTTED HEREON.

OWNER:
HOMAYOON SHAMOLIAN / JANET SHAMOLIAN
APN: 5534-002-005

INSTRUMENT NO. 2020077804, O.R.

LEGEND:

●	Bollard
⊠	Electric Box
○	Electric Conduit
⊠	Fire Dept Connection
⊠	Fire Service Riser
⊠	Gas Meter
⊠	Gas Riser
⊠	Gas Valve
→	Guy Pole/Wire
⊠	Light Pole
⊠	Parking Meter
⊠	Roof Drain
⊠	Sign Bus Stop
⊠	Sign HDPC
⊠	Sign Misc
⊠	Street Light
⊠	Street Light Box
⊠	Telephone Vault
⊠	Traffic Signal
⊠	Traffic Signal Box
⊠	Traffic Signal w/Arm
⊠	Tree-Misc
⊠	Tree-palm
⊠	Water Meter

○ — Iron Fence
— — Block Wall

CERTIFICATION
TO MIG REAL ESTATE AND/OR ITS ASSIGNS AND SUCCESSORS AND CHICAGO TITLE INSURANCE COMPANY:
THIS IS TO CERTIFY THAT THIS MAP OR PLAT AND THE SURVEY ON WHICH IT IS BASED WERE MADE IN ACCORDANCE WITH THE 2016 MINIMUM STANDARD DETAIL REQUIREMENTS FOR ALTA/NSPS LAND TITLE SURVEYS, JOINTLY ESTABLISHED AND ADOPTED BY ALTA AND NSPS, AND INCLUDES ITEMS 1, 2, 3, 4, 5, 6A, 7A, 7B1, 8, 9, 10, 11, 13, 14, 16, 17 & 20 OF TABLE A THEREOF. THE FIELD WORK WAS COMPLETED ON 09/16/2020.
DATE OF PLAT OR MAP: 09/24/2020
DATE OF LAST REVISION: 10/13/2020



SURVEYOR'S NOTES
THIS SURVEY WAS MADE ON THE GROUND UNDER MY SUPERVISION.
INFORMATION SHOWN HEREON IS BASED ON CHICAGO TITLE INSURANCE COMPANY ORDER# 00128357-021-PS4-JC, DATED AS OF JULY 31, 2020, AS WELL AS A COPY OF EACH INSTRUMENT LISTED THEREIN, AND THE SUBJECT LAND AND EACH PARCEL THEREOF DESCRIBED IN THIS SURVEY IS THE SAME LAND AS DESCRIBED IN THE TITLE COMMENT INDICATED THEREIN.
THE SUBJECT PROPERTY HAS DIRECT PHYSICAL ACCESS TO VINE STREET AND LEXINGTON AVENUE, BOTH PUBLICLY DEDICATED AND MAINTAINED ROADS.

- TABLE "A" ITEMS**
- PROPERTY ADDRESS: 1212-1218 VINE ST., LOS ANGELES, CA PER TITLE REPORT.
 - PROPERTY IS IN ZONE X: 0.2% ANNUAL CHANCE FLOOD HAZARD, PER FEMA MAP 06037C1605F, EFFECTIVE ON 09/26/2008.
 - GROSS AREA = 43,956 S.F. / 1.01 AC. ±
 - VERTICAL RELIEF SHOWN HEREON.
 - ZONING: C2-10
 - A ZONING REPORT OR LETTER WAS NOT PROVIDED BY THE CLIENT. IT IS THE RESPONSIBILITY OF THE INSURED TO VERIFY THE ZONING INFORMATION.
 - EXTERIOR DIMENSIONS OF ALL BUILDINGS & SQUARE FOOTAGE OF EXTERIOR BUILDING AT GROUND LEVEL SHOWN HEREON.
 - SUBSTANTIAL FEATURES OBSERVED IN THE PROCESS OF CONDUCTING THE SURVEY ARE SHOWN HEREON.
 - PARKING: 28 REGULAR, 10 TANDEM, 2 ACCESSIBLE. TOTAL = 50 STALLS.
 - N/A
 - LOCATION OF UTILITIES EXISTING ON OR SERVING THE SURVEYED PROPERTY AS DETERMINED BY OBSERVED EVIDENCE ONLY.
 - ADJACENT OWNERS SHOWN HEREON.
 - DISTANCE TO NEAREST INTERSECTION SHOWN HEREON. (SUBJECT PROPERTY IS ADJACENT TO THE NEAREST INTERSECTION).
 - THERE IS NO OBSERVABLE EVIDENCE OF EARTH MOVING WORK, BUILDING CONSTRUCTION OR BUILDING ADDITIONS WITHIN RECENT MONTHS.
 - SURVEYOR IS NOT AWARE OF ANY PROPOSED CHANGES IN STREET RIGHT OF WAY LINES. THERE IS NO EVIDENCE OF RECENT STREET OR SIDEWALK CONSTRUCTION OR REPAIRS OBSERVED IN THE PROCESS OF CONDUCTING THE FIELDWORK.

LEGAL DESCRIPTION

THE LAND REFERRED TO HEREIN BELOW IS SITUATED IN THE CITY OF LOS ANGELES, IN THE COUNTY OF LOS ANGELES, STATE OF CALIFORNIA, AND IS DESCRIBED AS FOLLOWS:
PARCEL 1:
THAT PORTION OF BLOCK 12 OF COLEGROVE, IN THE CITY OF LOS ANGELES, COUNTY OF LOS ANGELES, STATE OF CALIFORNIA, AS PER MAP RECORDED IN BOOK 53 PAGE 10 OF MISCELLANEOUS RECORDS, IN THE OFFICE OF THE COUNTY RECORDER OF SAID COUNTY, DESCRIBED AS FOLLOWS: BEGINNING AT THE INTERSECTION OF THE NORTH LINE OF LEXINGTON AVENUE (FORMERLY EMILITA AVENUE) WITH THE EAST LINE OF VINE STREET; THENCE NORTHERLY ALONG SAID EAST LINE OF VINE STREET 150 FEET; THENCE EAST PARALLEL WITH SAID NORTH LINE OF LEXINGTON AVENUE 198 FEET; THENCE SOUTHERLY PARALLEL WITH SAID EAST LINE OF VINE STREET 150 FEET TO THE NORTH LINE OF SAID LEXINGTON AVENUE; THENCE WESTERLY ALONG SAID NORTHERLY LINE TO THE POINT OF BEGINNING.
PARCEL 2:
THAT PORTION OF BLOCK 12 OF COLEGROVE, IN THE CITY OF LOS ANGELES, COUNTY OF LOS ANGELES, STATE OF CALIFORNIA, AS PER MAP RECORDED IN BOOK 53, PAGE 10 OF MISCELLANEOUS RECORDS, OF SAID COUNTY, DESCRIBED AS PARCELS NO. 2 AND NO. 3 IN DEED TO CITY OF LOS ANGELES, RECORDED IN BOOK 7822, PAGE 44 OF OFFICIAL RECORDS, IN THE OFFICE OF THE COUNTY RECORDER OF SAID COUNTY. APN: 5534-002-023 & 018

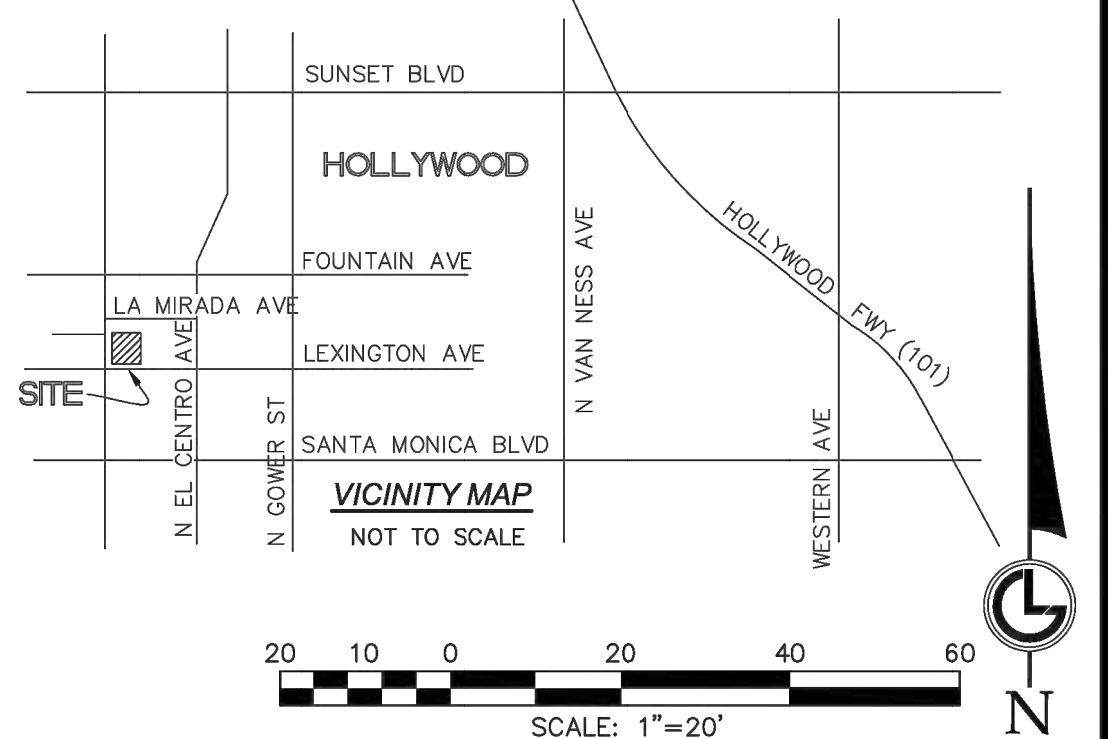

Revisions

No.	Description	By	Date
1	CLIENT COMMENTS (REVISION TO EXC. ITEM 4)	JPG	10/13/2020

BASIS OF BEARINGS:
THE BASIS OF BEARINGS FOR THIS SURVEY IS THE CENTERLINE OF LEXINGTON AVENUE PER RS 303-20, I.E. N89°55'50"E.

BASIS OF ELEVATIONS:
THE BASIS OF ELEVATIONS FOR THIS SURVEY IS THE CITY OF LOS ANGELES BENCHMARK 12-13650, WIRE SPIKE IN W. CURB VINE ST. 9FT. N. OF LEXINGTON AVE. N. END. CB. EL. = 311.692, NAVD. 88.

ALTA/NSPS LAND TITLE SURVEY
PORTION BLOCK 12
COLEGROVE, M.R. 53/10
LOS ANGELES, CA

Drawn By: JPG
Checked By:

Project No. 20-121
Date: Sheet 1 of 1

PROJECT NAME:
VINE STREET



Architecture + Planning
888.456.5849
ktgy.com

Grubb
4601 Park Road, Suite 450
Charlotte, NC 28209

1200 VINE STREET
LOS ANGELES, CA # 2021-1034

CONCEPTUAL DESIGN
JULY 26, 2022

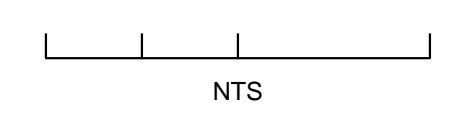

SITE SURVEY

A0-4



PROJECT SUMMARY
SCHEME A

1200 VINE STREET
LOS ANGELES, CA

ZONING: [Q] C2-2D-CPIO
HOLLYWOOD COMMUNITY PLAN -- TOC TIER 1

AREA: 0.93 ACRES (40,787 SF)
UNITS: 153 DU
DENSITY: 164.5 DU/AC

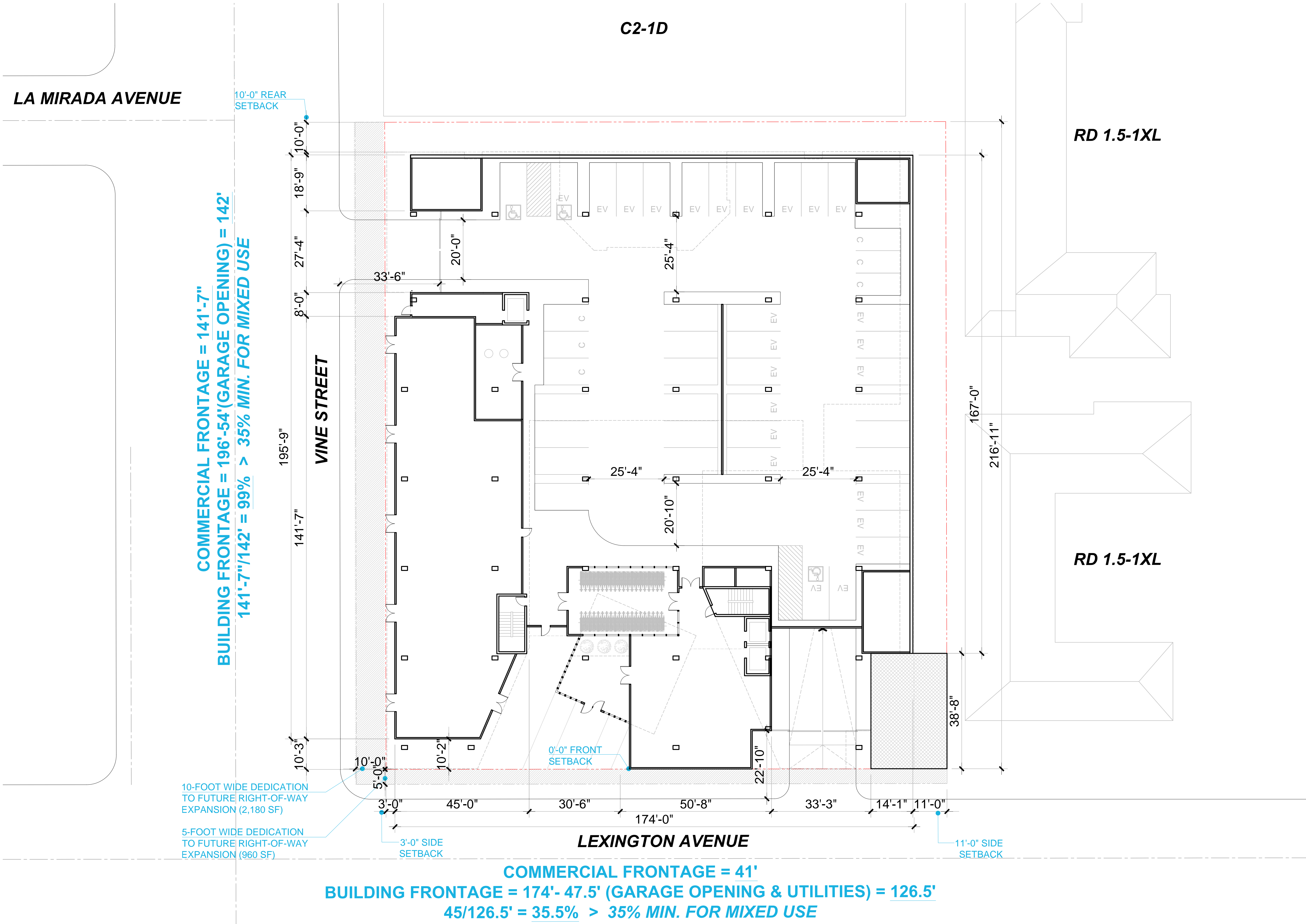

Architecture + Planning
888.456.5849
ktgy.com

Grubb
4601 Park Road, Suite 450
Charlotte, NC 28209

1200 VINE STREET
LOS ANGELES, CA # 2021-1034

CONCEPTUAL DESIGN
JULY 26, 2022



SITE PLAN
PROJECT SUMMARY

A1-0

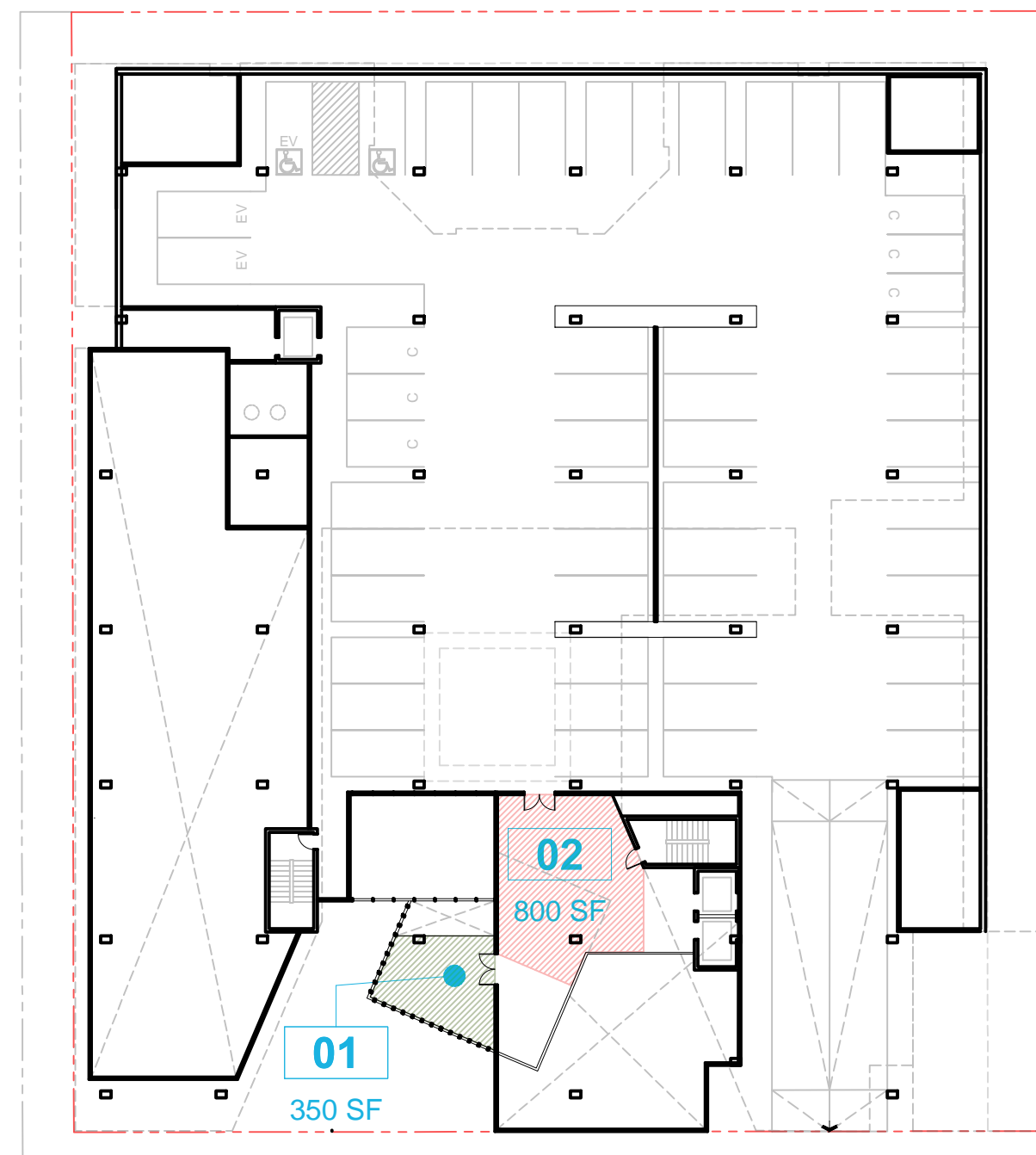

LEVEL 02

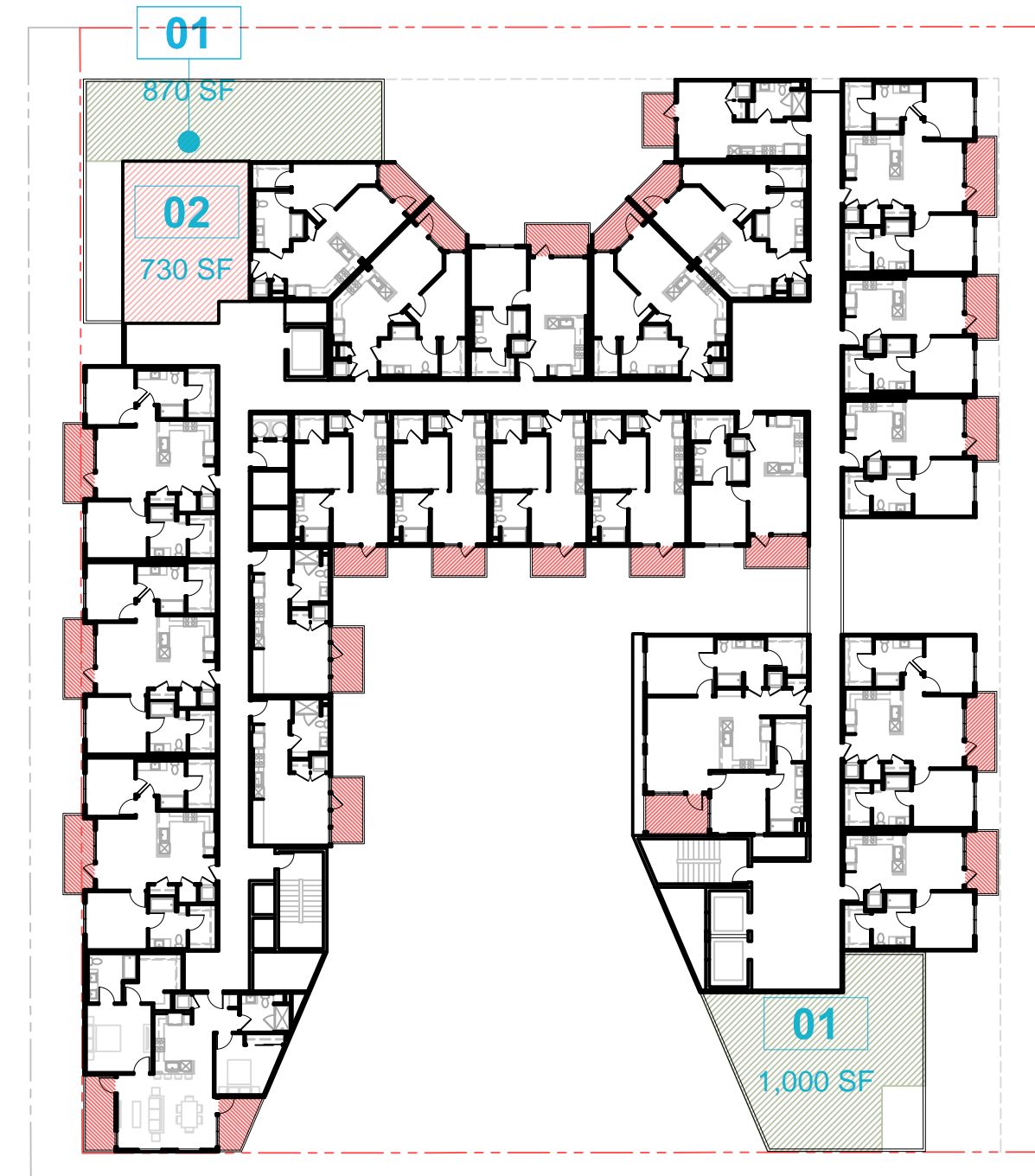

LEVEL 08

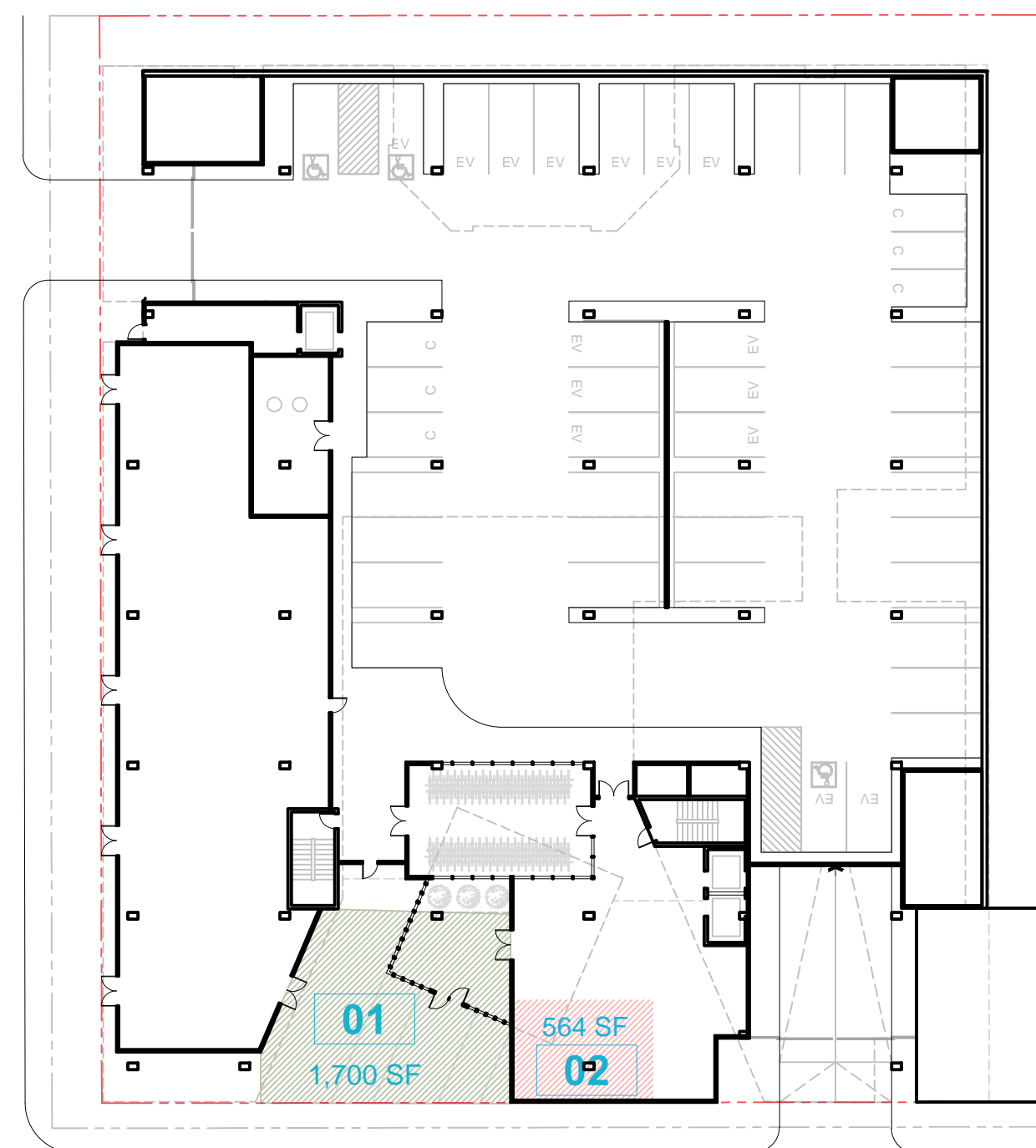

LEVEL 01

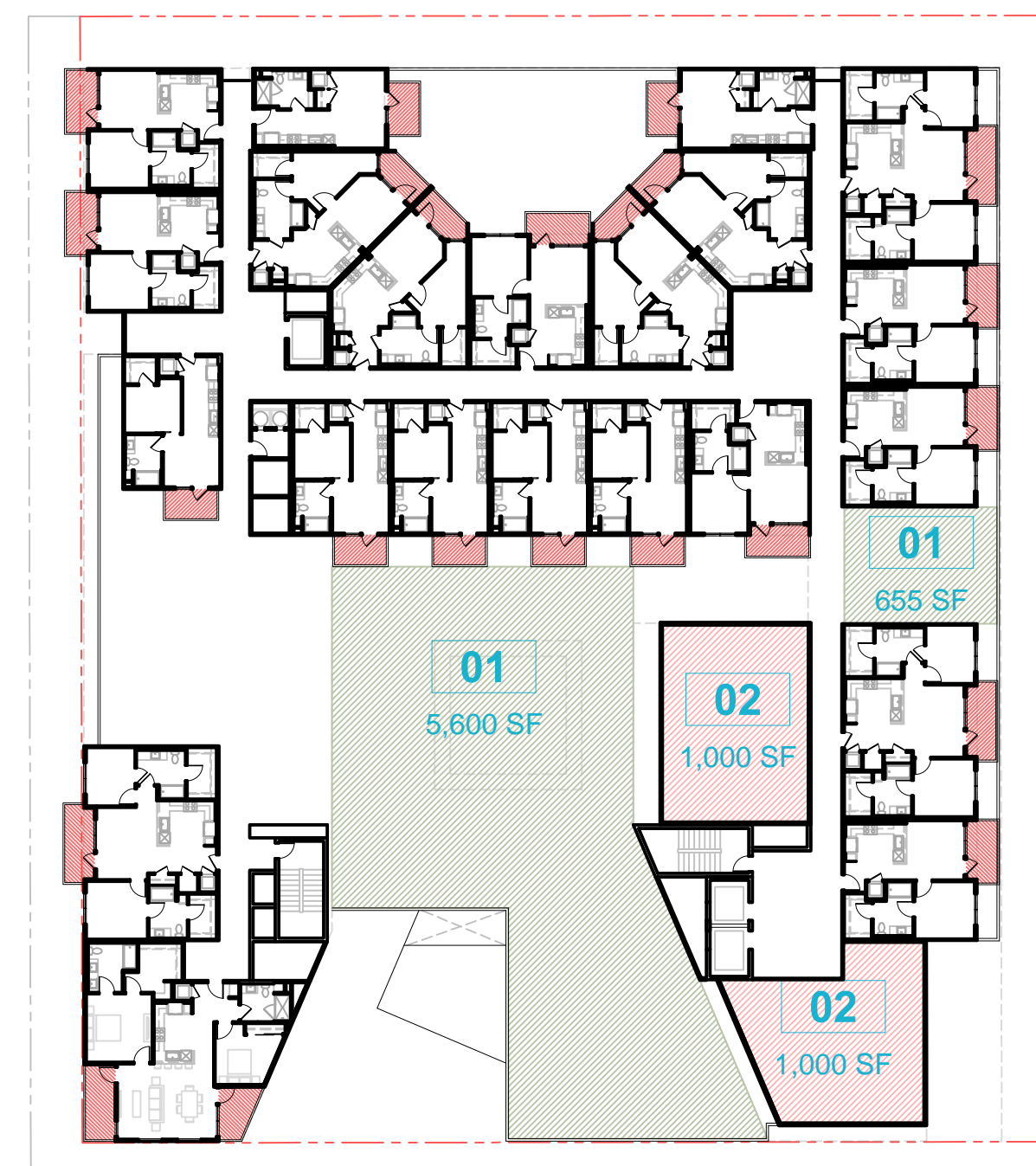

LEVEL 03

NOTES

- 1 TREE PER 4 DU REQUIRED
153 DU / 4 = 39 TREES REQUIRED
(REFER TO LANDSCAPE DRAWINGS FOR MORE INFO)

SYMBOLS

1. [Hatched Pattern] OUTDOOR COMMON OPEN SPACE
2. [Red Hatched Pattern] INDOOR COMMON OPEN SPACE
3. [Blue Hatched Pattern] PRIVATE OPEN SPACE
- BALCONIES WITH 6' MIN DIM IN LENGTH AND WIDTH
- SEE A5-0 UNIT PLAN SHEETS FOR BALCONY DIMS

OPEN SPACE			
REQUIRED	OPEN SPACE PER R4 ZONE		
STUDIO UNITS	21	100 PER UNIT	2,100
ONE BEDROOM UNITS	89	100 PER UNIT	8,900
TWO BEDROOM UNITS	43	125 PER UNIT	5,375
	153 UNITS	REQUIRED OPEN SPACE	16,375 SF

PROVIDED	OPEN SPACE
PRIVATE DECKS (50sf max.)	7,650 SF
OUTDOOR OPEN SPACE - L1	1,700 SF
CO-WORK DECK - L2	NA
PODIUM COURTYARD - L3	6,255 SF
ROOF DECK A - L8	870 SF
ROOF DECK B - L8	1,000 SF
INDOOR AMENITIES (max. 25% of total req.)	4,094 SF
TOTAL	21,569 SF



Architecture + Planning
888.456.5849
ktgy.com

Grubb
4601 Park Road, Suite 450
Charlotte, NC 28209

1200 VINE STREET
LOS ANGELES, CA # 2021-1034

CONCEPTUAL DESIGN
JULY 26, 2022

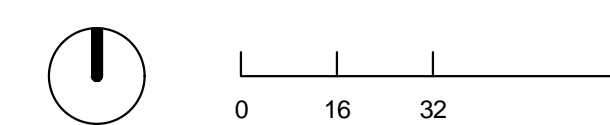

OPEN SPACE EXHIBIT

A1-2

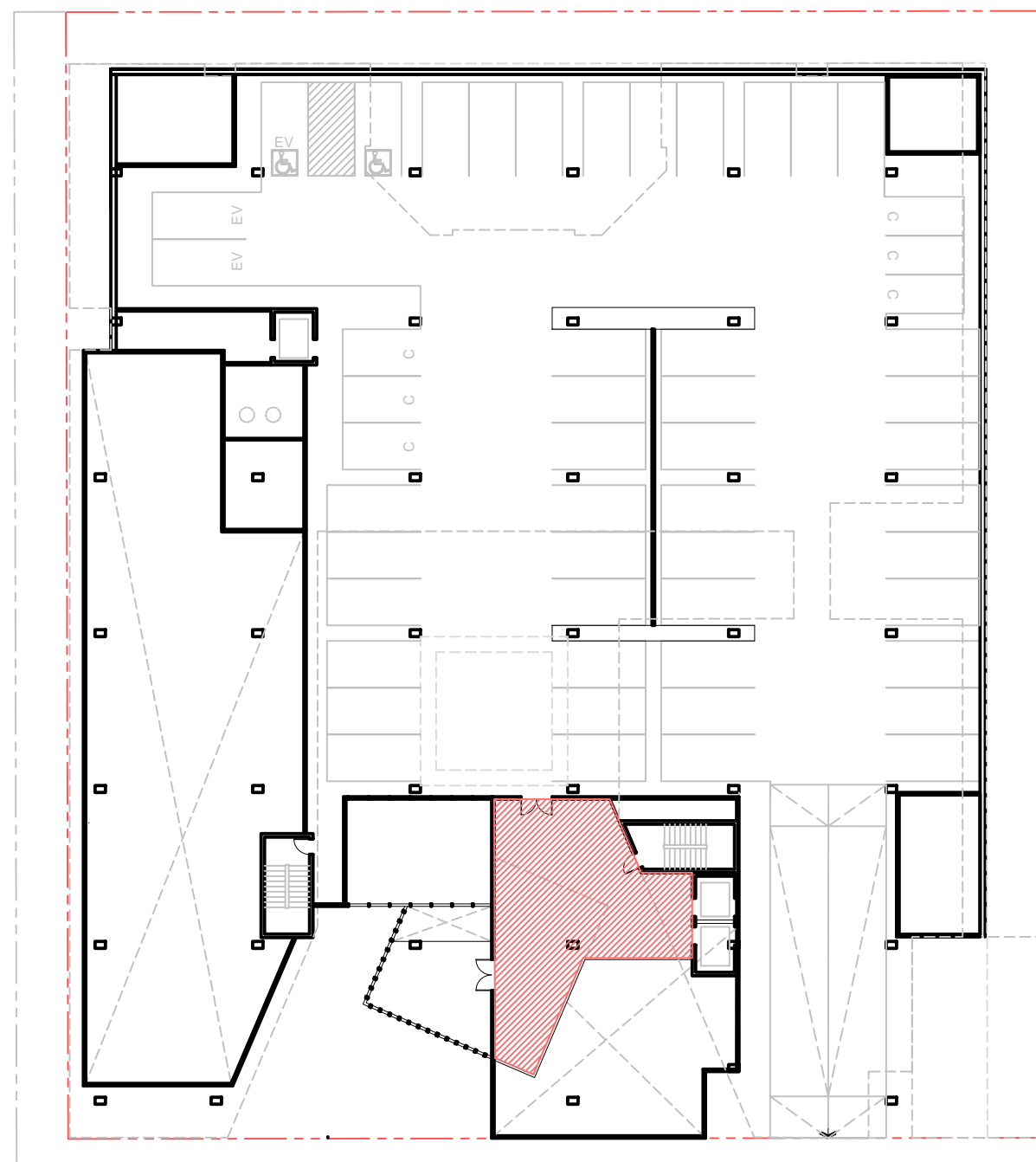

LEVEL 02



LEVEL 08

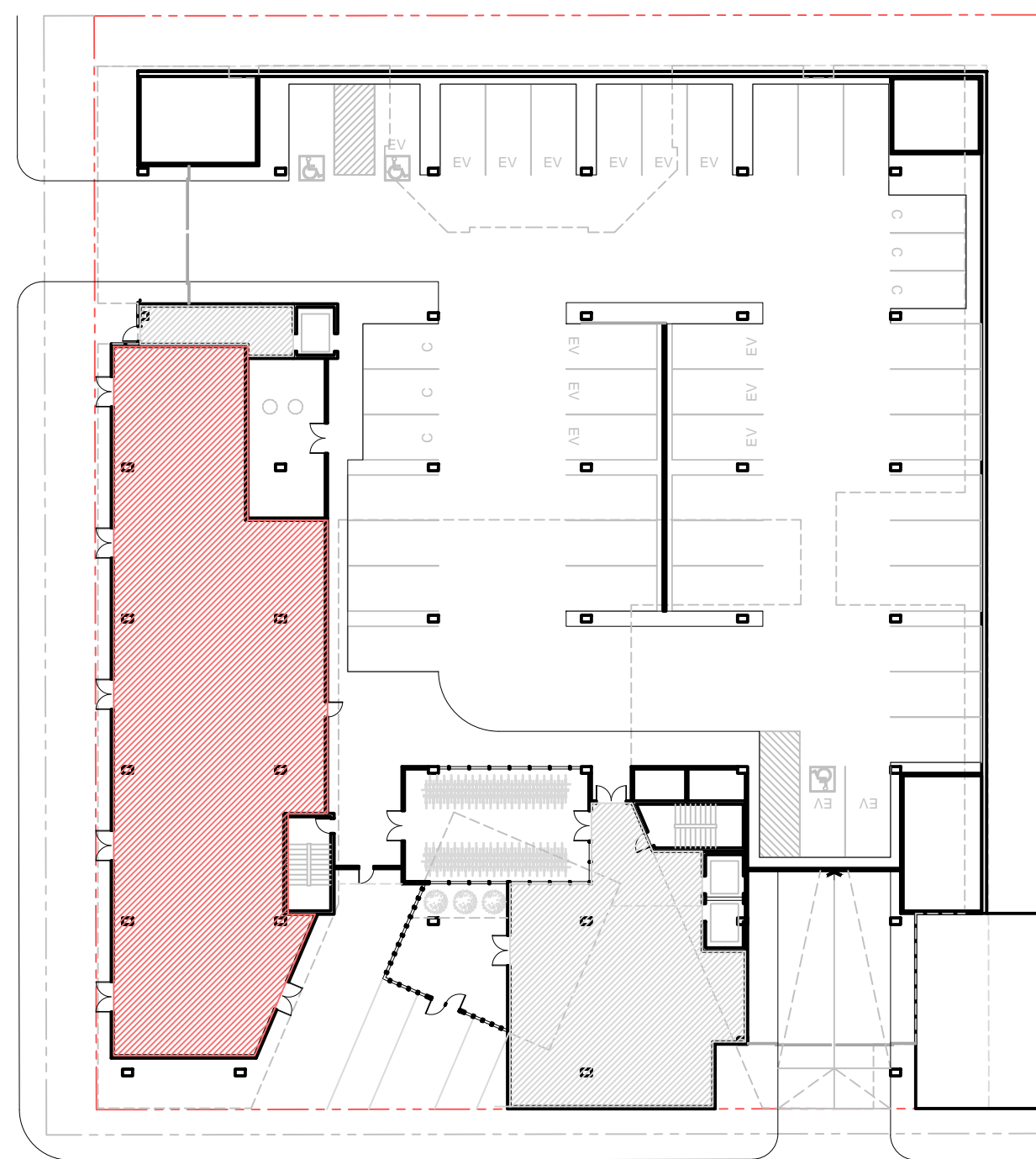

LEVEL 01

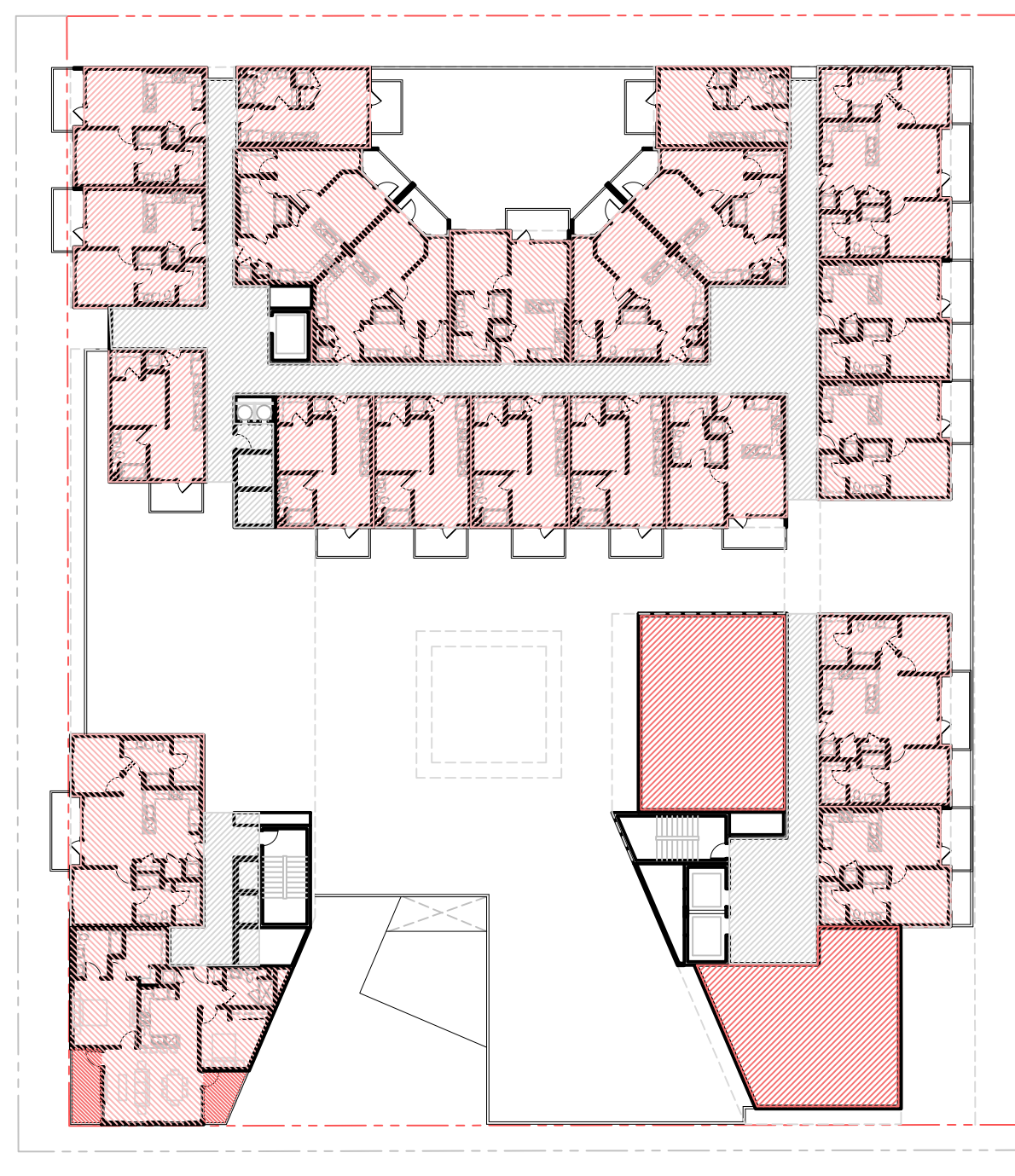

LEVEL 03

SYMBOLS

- 1. AMENITY SPACE
- 2. RESIDENTIAL
- 3. COMMON SPACE

FAR TABLE		
LOT SIZE: 40,786 SQFT		
	FAR	SQFT PERMITTED
C2-1D ZONE	.5:1	20,393 SF
[Q]C2-2D-CPIO (BASE)	1.5:1	61,179 SF
[Q]C2-2D-CPIO (BONUS)	3.0:1	122,358 SF
PROPOSED	3.5:1	143,295 SF

FLOOR AREA SUMMARY

FLOOR / LEVEL	APARTMENT UNITS	RESIDENTIAL UNIT AREA	COMMON AREAS / CIRCULATION	AMENITY / LOBBY / RETAIL AREA	BALC. AREA (INCL. IN FAR)	TOTAL FLOOR AREA	GARAGE / MECH AREA	GROSS BUILDING AREA
1st FLOOR	0 UNITS	0 SF	950 SF	9,975 SF	0 SF	10,110 SF	21,865 SF	31,975 SF
2nd FLOOR	0 UNITS	0 SF	101 SF	1,200 SF	0 SF	1,301 SF	23,170 SF	24,471 SF
3rd FLOOR	22 UNITS	14,033 SF	3,290 SF	2,000 SF	439 SF	19,762 SF	0 SF	19,762 SF
4th FLOOR	27 UNITS	18,644 SF	3,670 SF	0 SF	578 SF	22,892 SF	0 SF	22,892 SF
5th FLOOR	27 UNITS	18,644 SF	3,650 SF	0 SF	578 SF	22,872 SF	0 SF	22,872 SF
6th FLOOR	27 UNITS	18,644 SF	3,650 SF	0 SF	578 SF	22,872 SF	0 SF	22,872 SF
7th FLOOR	27 UNITS	18,644 SF	3,650 SF	0 SF	578 SF	22,872 SF	0 SF	22,872 SF
8th FLOOR	23 UNITS	15,924 SF	3,425 SF	735 SF	533 SF	20,617 SF	0 SF	20,617 SF
Total	153 UNITS	104,533 SF	22,386 SF	13,910 SF	3,281 SF	143,295 SF	45,035 SF	188,330 SF



Architecture + Planning
888.456.5849
ktgy.com

Grubb
4601 Park Road, Suite 450
Charlotte, NC 28209

1200 VINE STREET
LOS ANGELES, CA # 2021-1034

CONCEPTUAL DESIGN
JULY 26, 2022

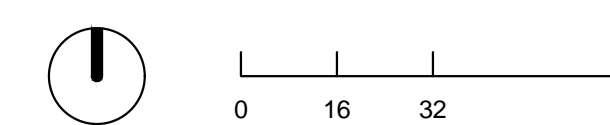

FAR EXHIBIT

A1-3

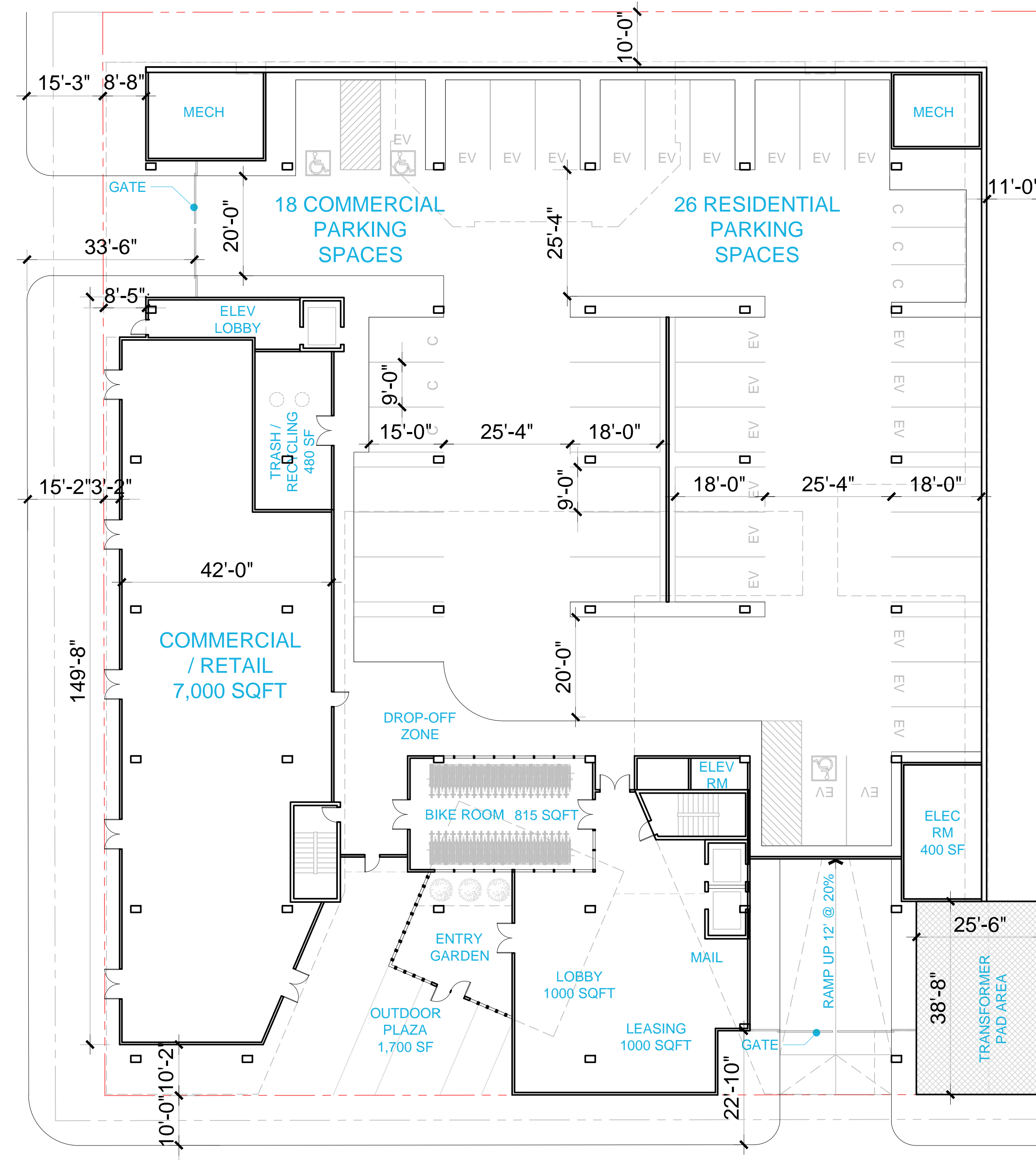

VINE STREET

LEXINGTON AVENUE



Architecture + Planning
888.456.5849
ktgy.com

Grubb
4601 Park Road, Suite 450
Charlotte, NC 28209

1200 VINE STREET
LOS ANGELES, CA # 2021-1034

CONCEPTUAL DESIGN
JULY 26, 2022

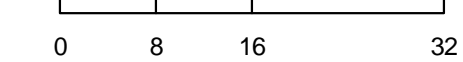
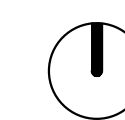

BUILDING PLAN
GROUND FLOOR

A3-0

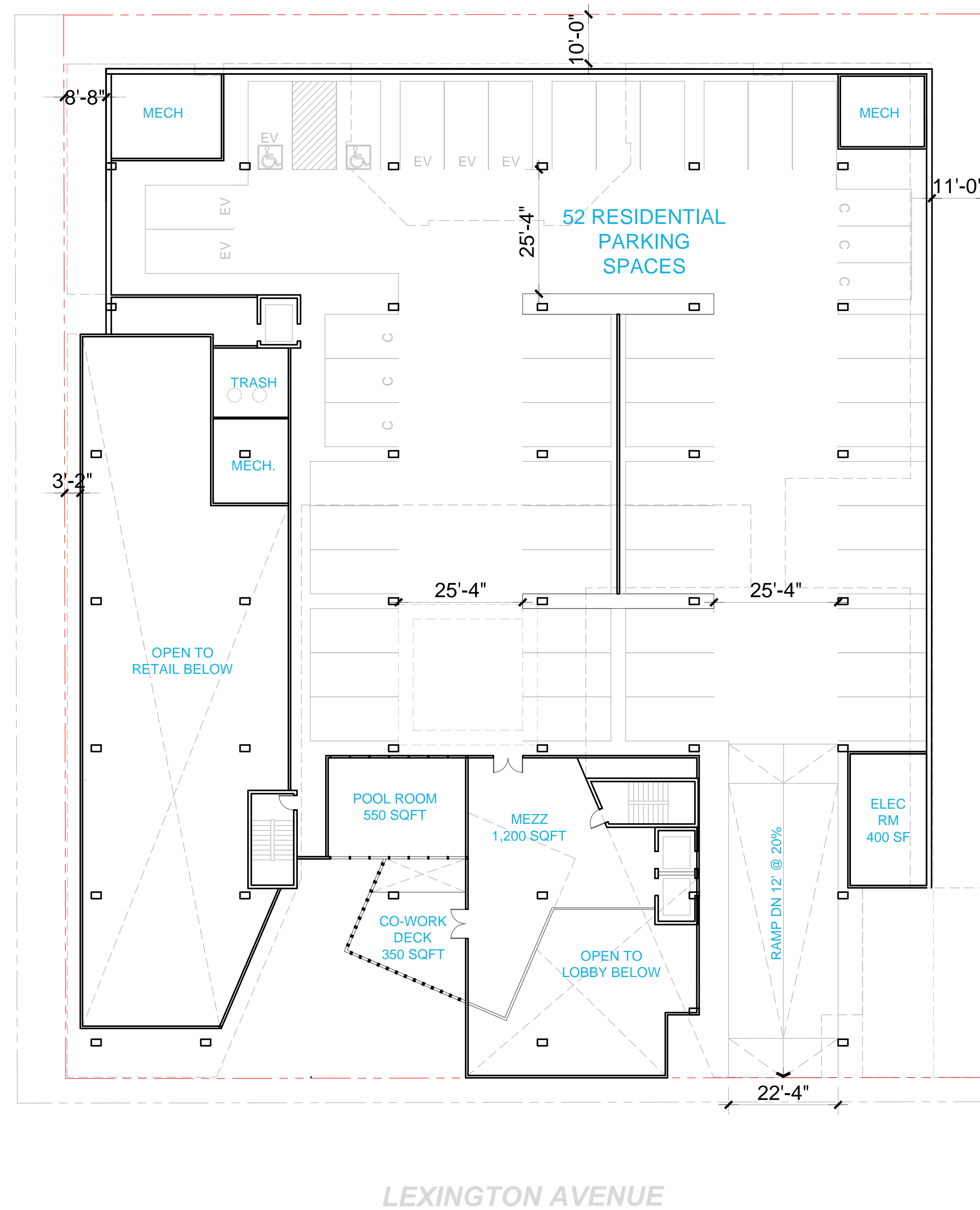

Architecture + Planning
888.456.5849
ktgy.com

Grubb
4601 Park Road, Suite 450
Charlotte, NC 28209

1200 VINE STREET
LOS ANGELES, CA # 2021-1034

CONCEPTUAL DESIGN
JULY 26, 2022

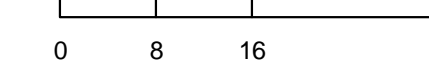
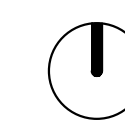

BUILDING PLAN
SECOND FLOOR

A3-1



Architecture + Planning
888.456.5849
ktgy.com

Grubb
4601 Park Road, Suite 450
Charlotte, NC 28209

1200 VINE STREET
LOS ANGELES, CA # 2021-1034

CONCEPTUAL DESIGN
JULY 26, 2022

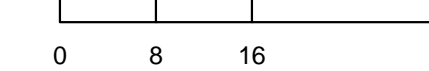
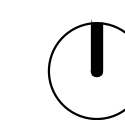

BUILDING PLAN
THIRD FLOOR

A3-2

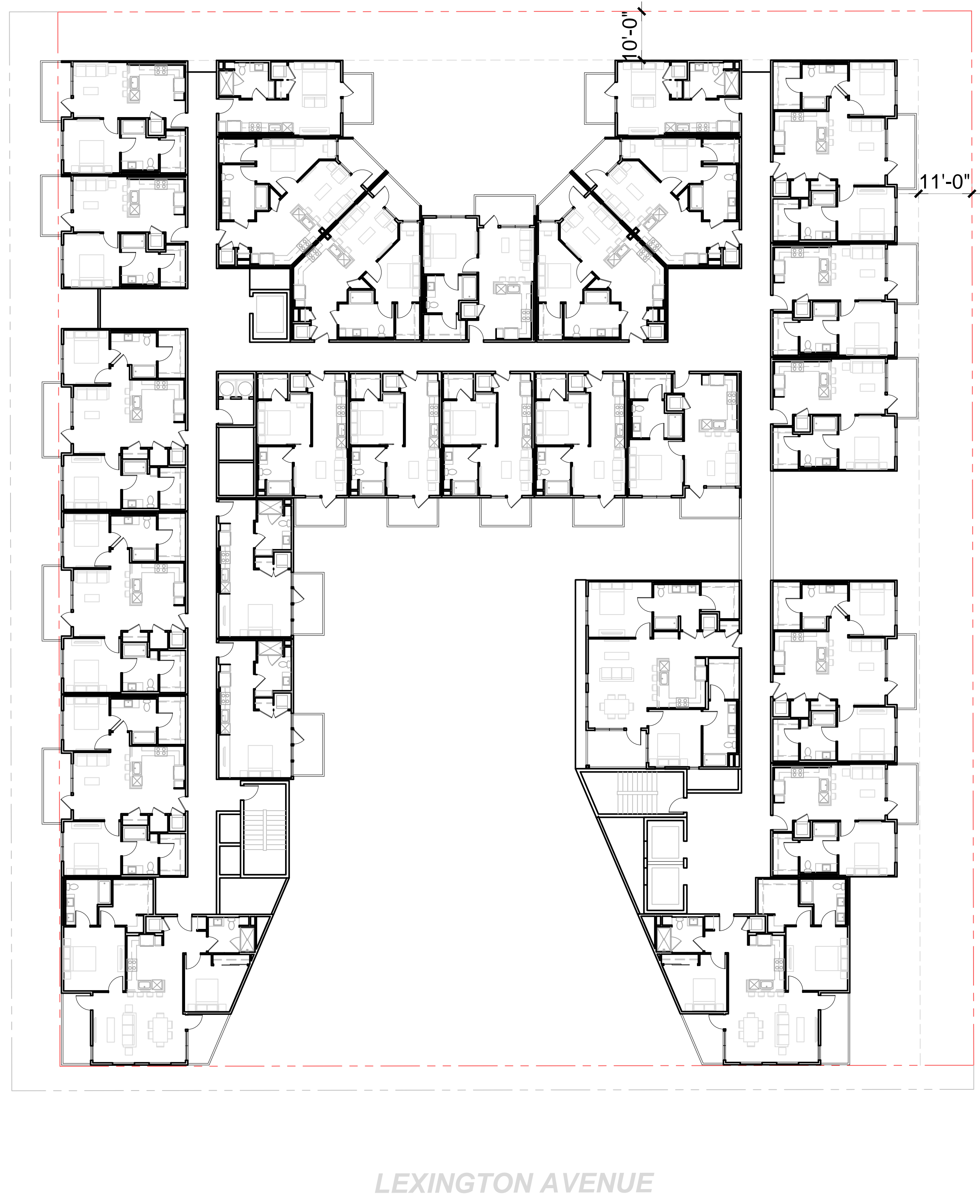

Architecture + Planning
888.456.5849
ktgy.com

Grubb
4601 Park Road, Suite 450
Charlotte, NC 28209

1200 VINE STREET
LOS ANGELES, CA # 2021-1034

CONCEPTUAL DESIGN
JULY 26, 2022

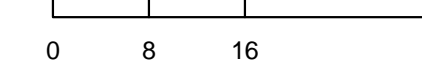
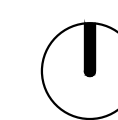

BUILDING PLAN
FOURTH-SEVENTH FLOOR

A3-3

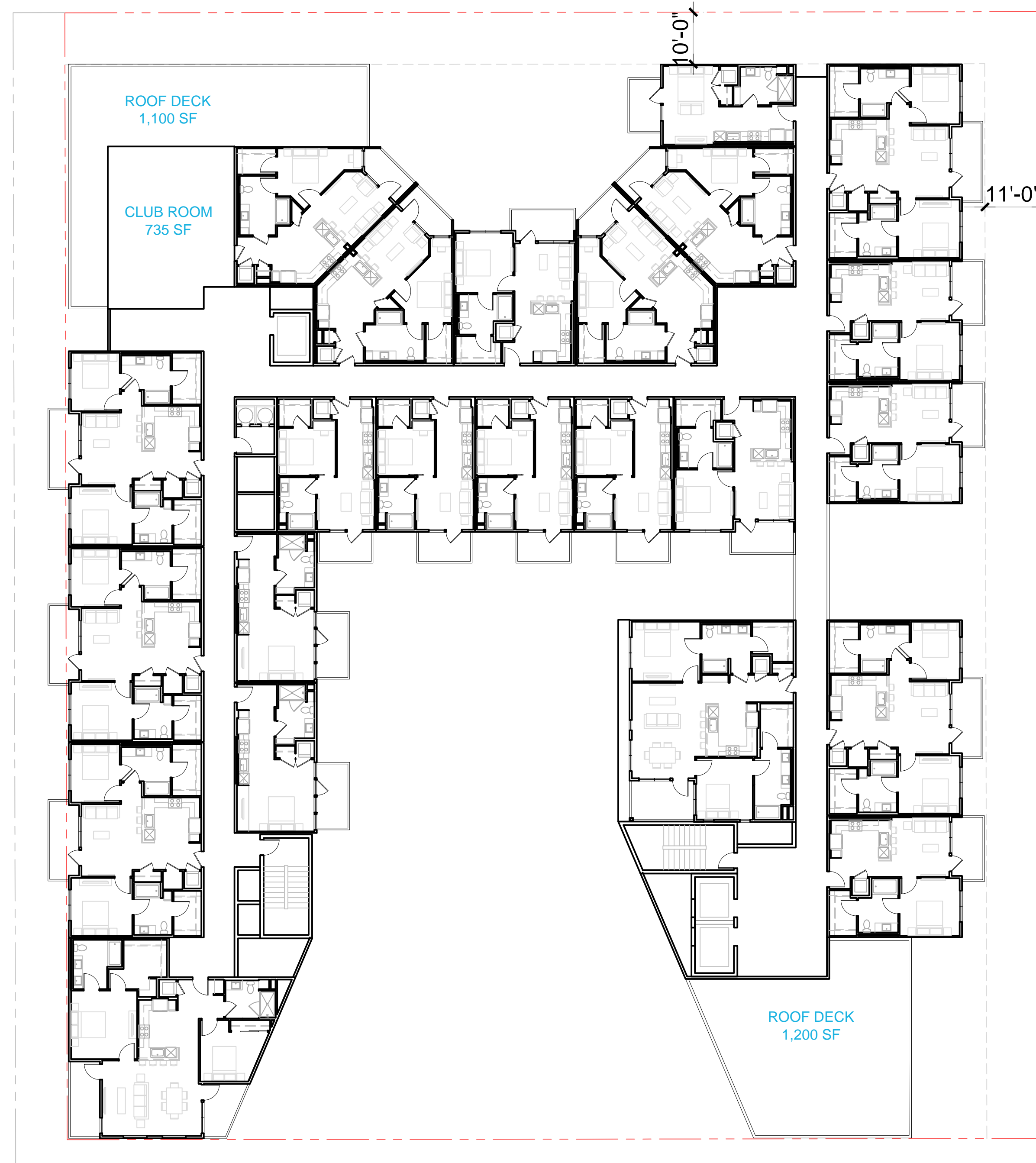

VINE STREET

LEXINGTON AVENUE



Architecture + Planning
888.456.5849
ktgy.com

Grubb
4601 Park Road, Suite 450
Charlotte, NC 28209

1200 VINE STREET
LOS ANGELES, CA # 2021-1034

CONCEPTUAL DESIGN
JULY 26, 2022

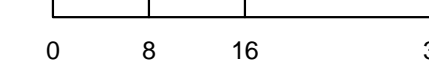
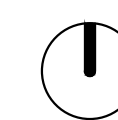

BUILDING PLAN
EIGHTH FLOOR

A3-4

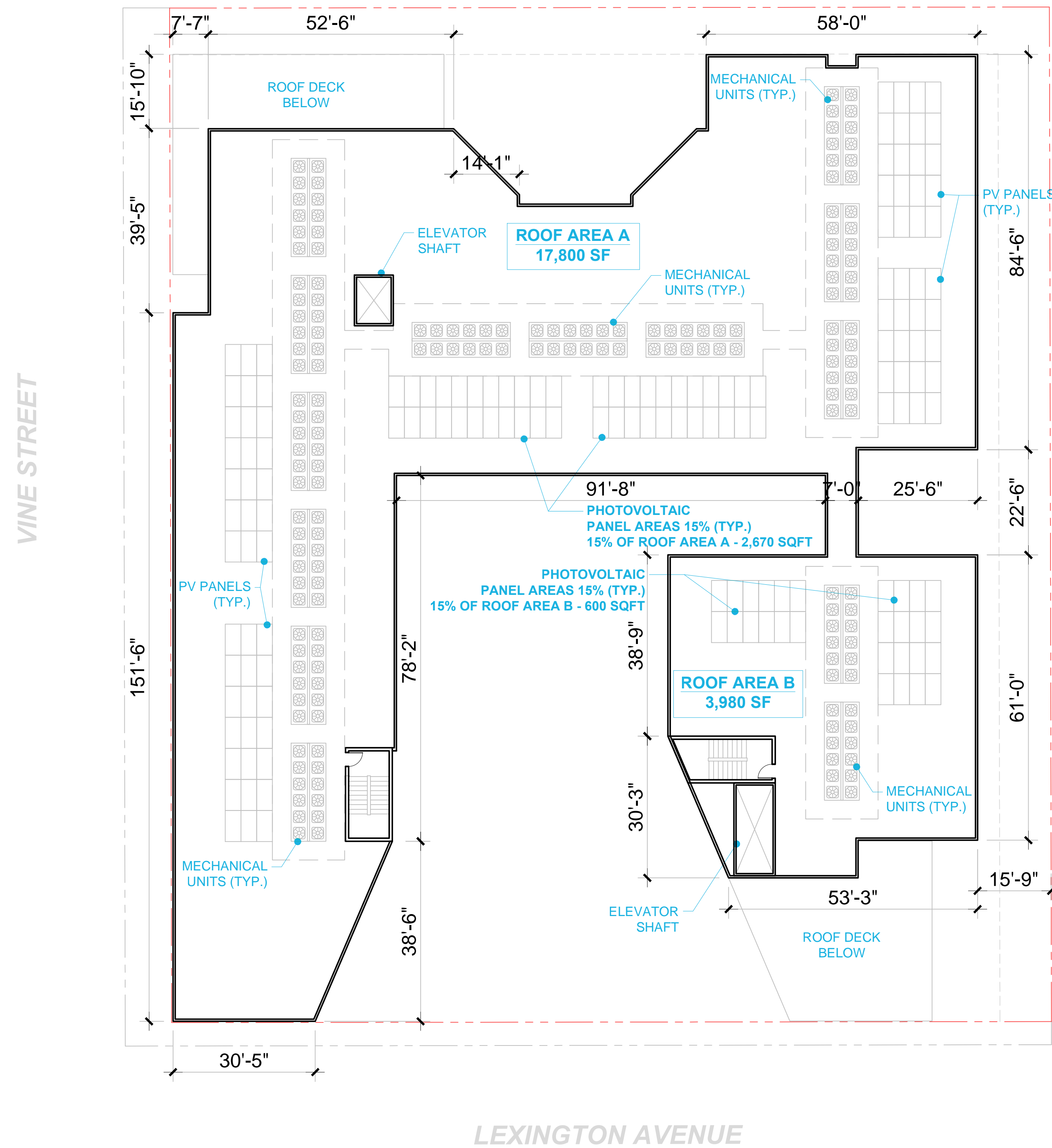

PHOTOVOLTAIC REQUIREMENT
15% OF THE ROOF AREA

ROOF AREA A - 17,800 SQFT
 _15% OF ROOF AREA A - 2,670 SQFT

ROOF AREA B - 3,980 SQFT
 _15% OF ROOF AREA B - 600 SQFT

TOTAL PHOTOVOLTAIC AREA ON ROOF
15% - 3,270 SQFT



Architecture + Planning
 888.456.5849
 ktgy.com

Grubb
 4601 Park Road, Suite 450
 Charlotte, NC 28209

1200 VINE STREET
 LOS ANGELES, CA # 2021-1034

CONCEPTUAL DESIGN
 JULY 26, 2022



BUILDING ROOF PLAN

A3-5

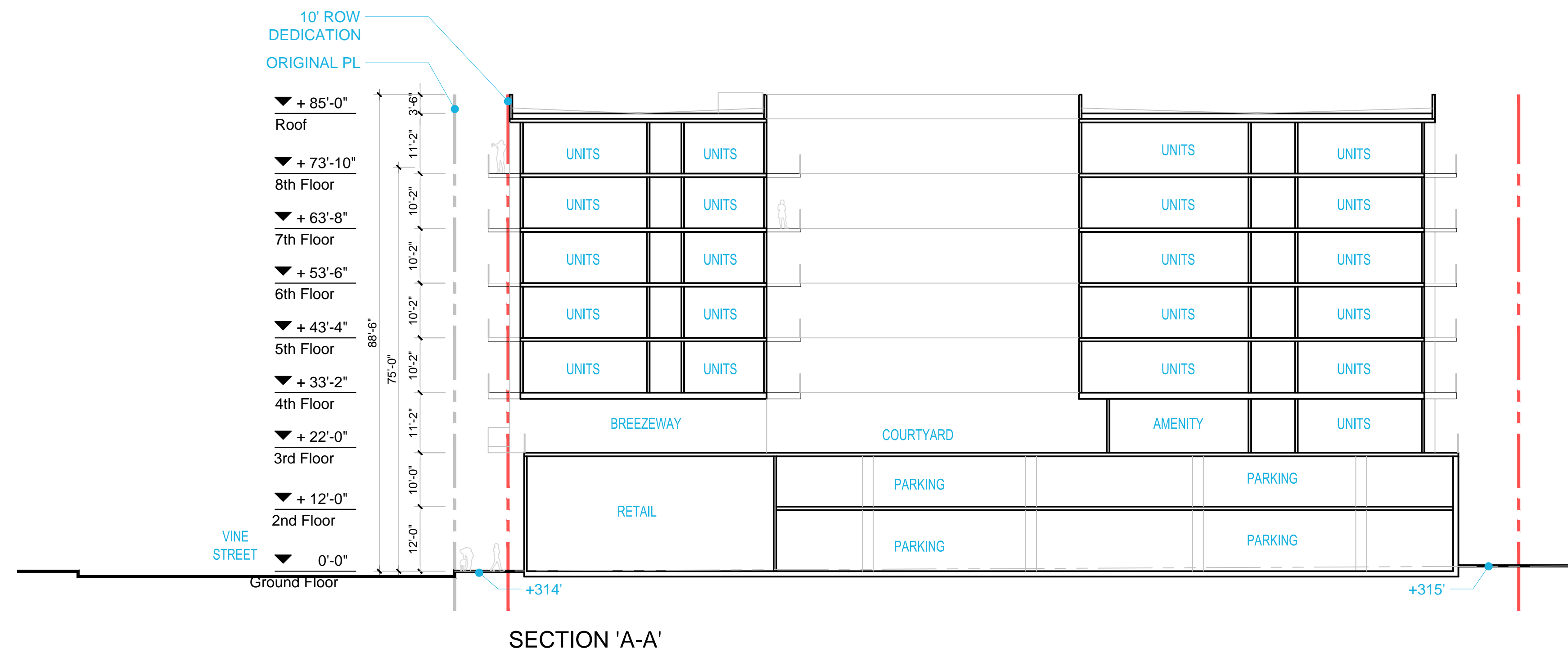
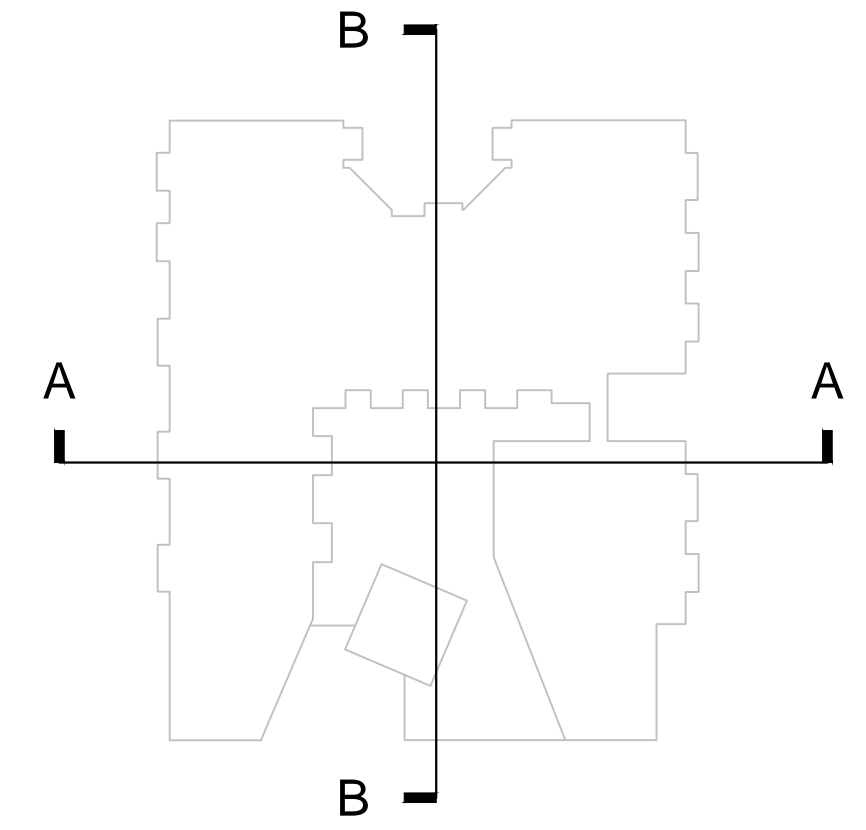

SECTION 'A-A'

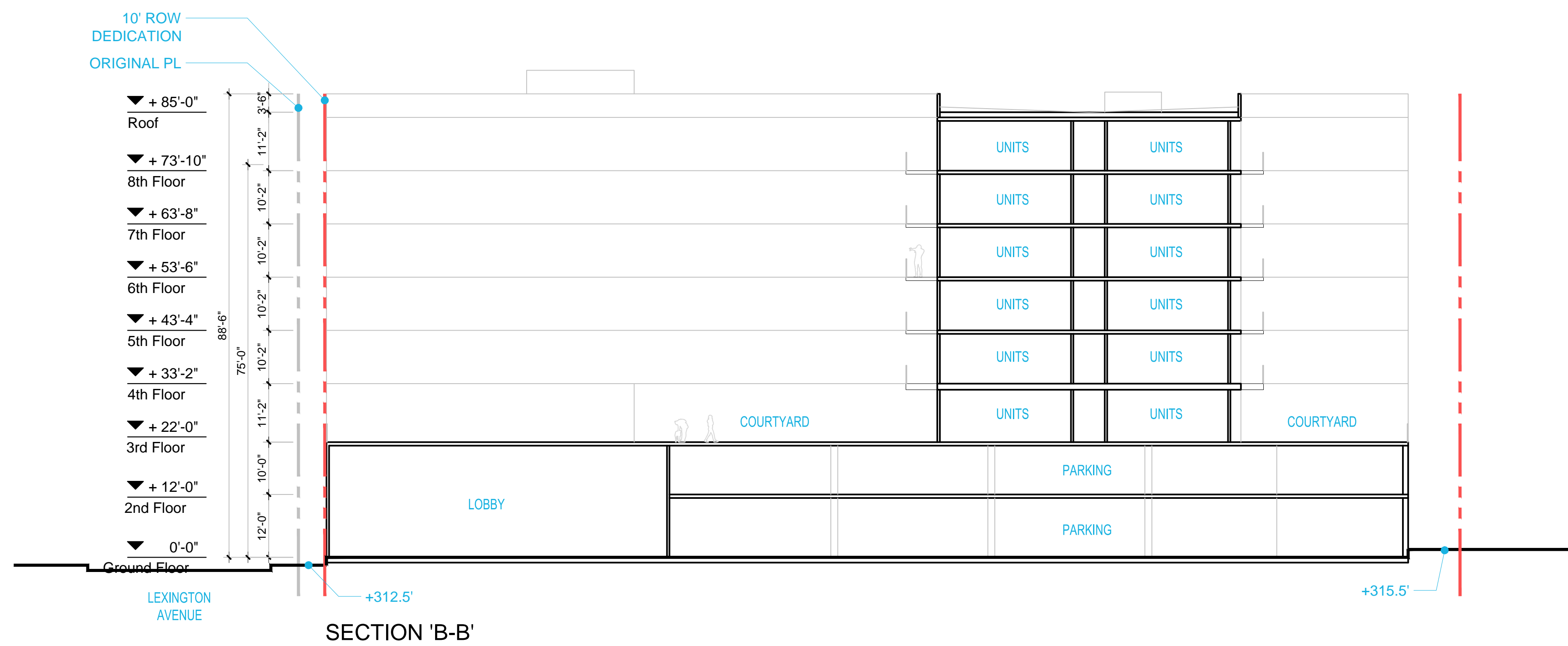

SECTION 'B-B'



Architecture + Planning
888.456.5849
ktgy.com

Grubb
4601 Park Road, Suite 450
Charlotte, NC 28209

1200 VINE STREET
LOS ANGELES, CA # 2021-1034

CONCEPTUAL DESIGN
JULY 26, 2022



BUILDING SECTIONS
SECTION A-A & B-B

A4-0

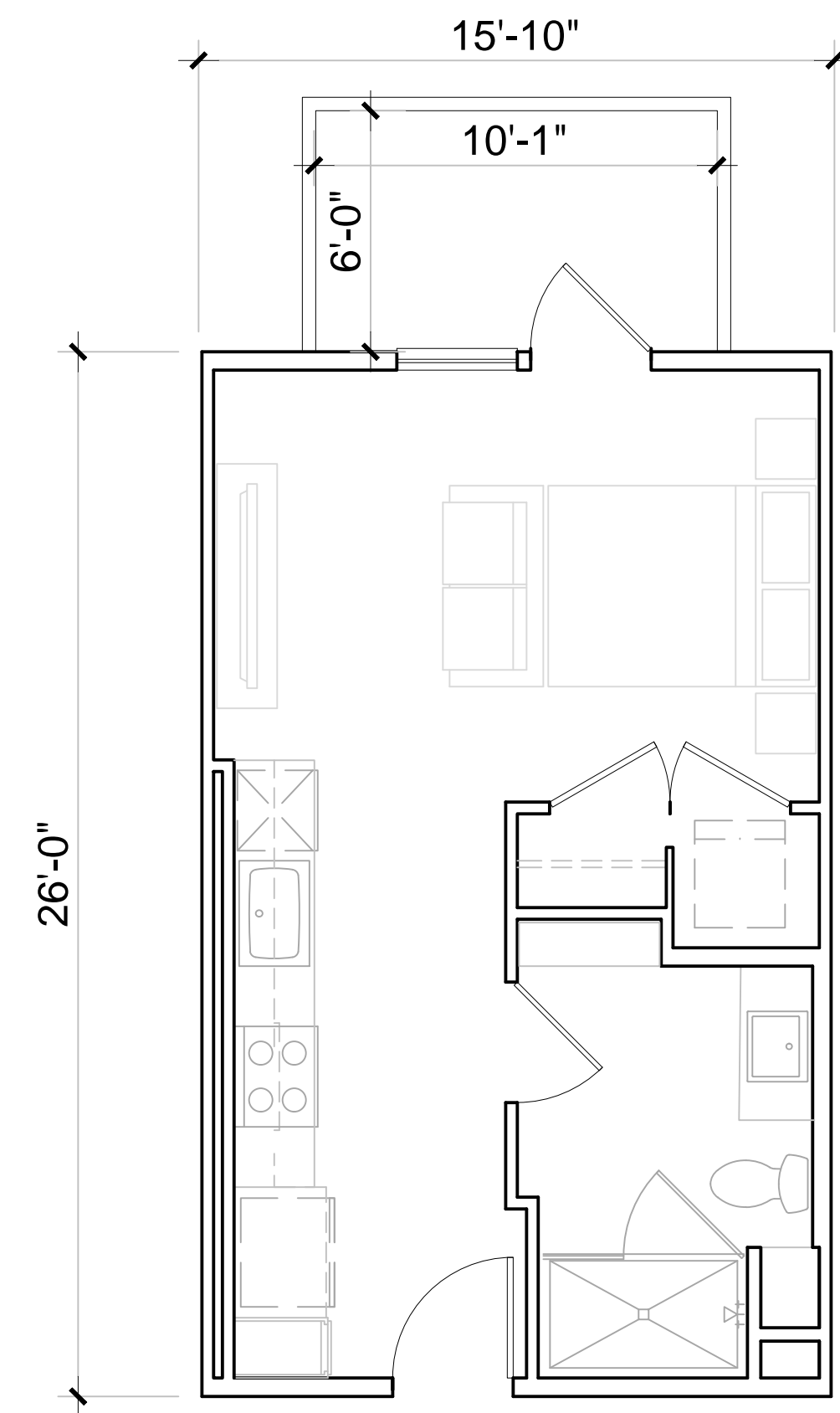

PLAN S1
STUDIO
1 BATH
412 SF

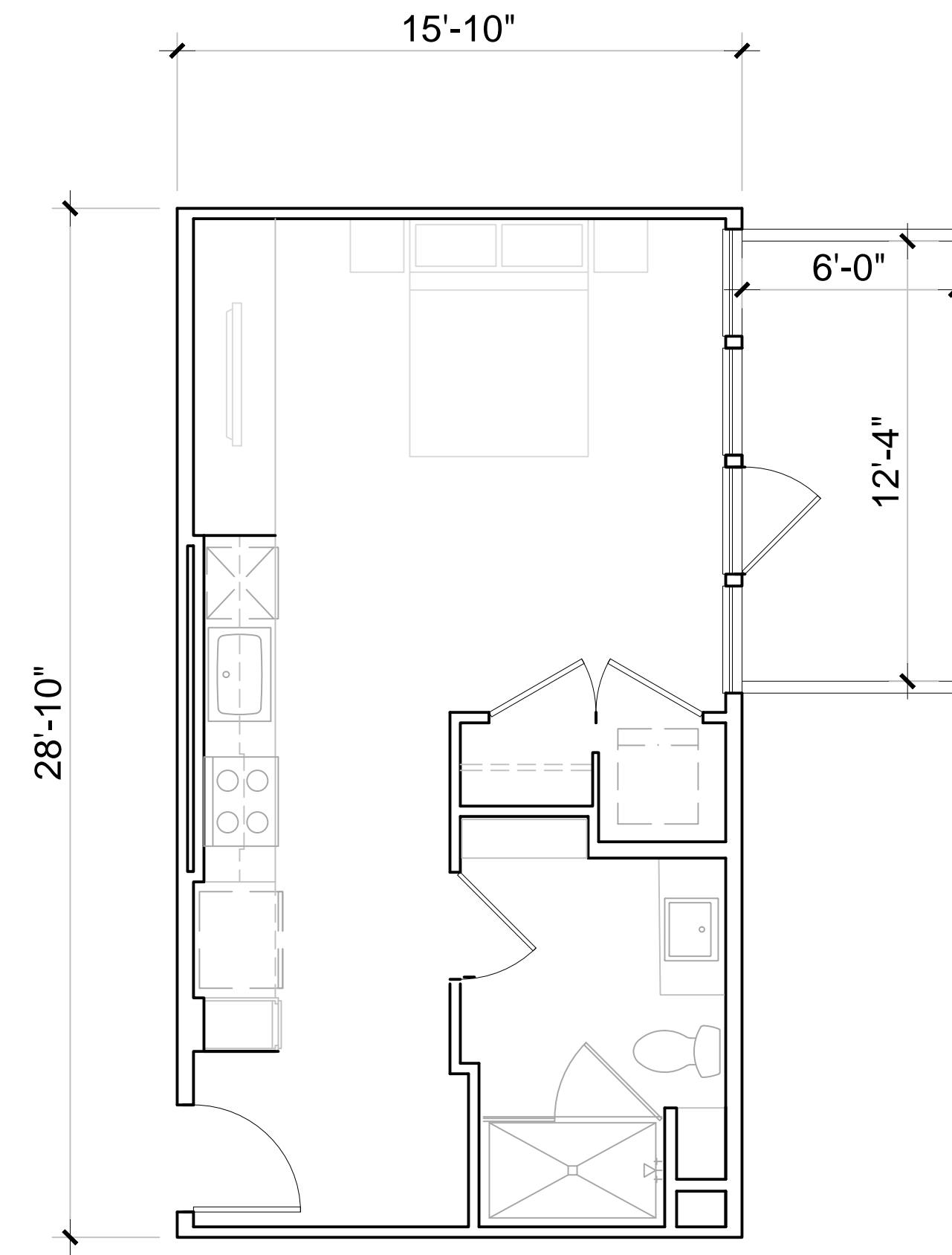

PLAN S1-ALT
STUDIO
1 BATH
460 SF

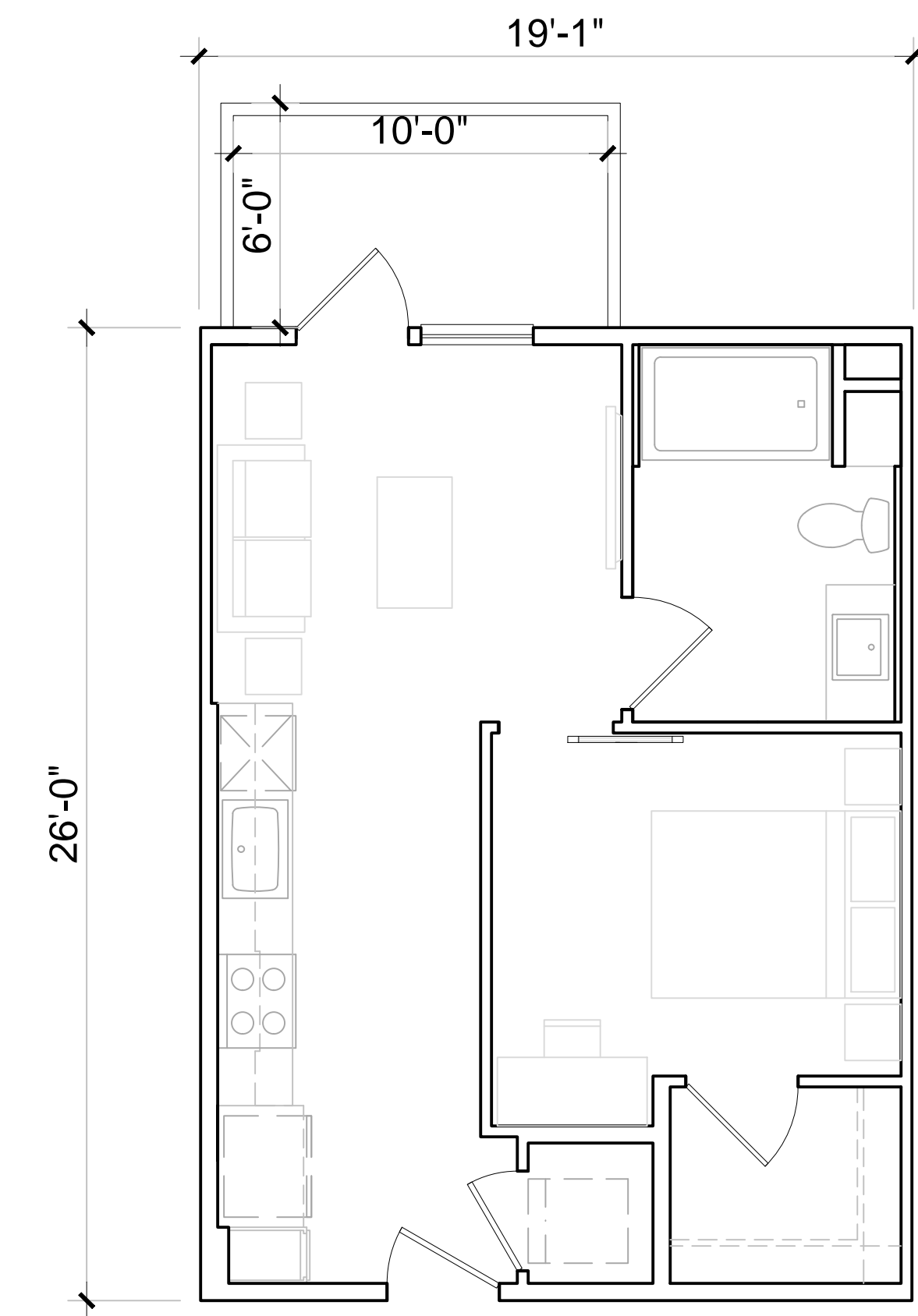

PLAN A1
1 BEDROOM
1 BATH
496 SF

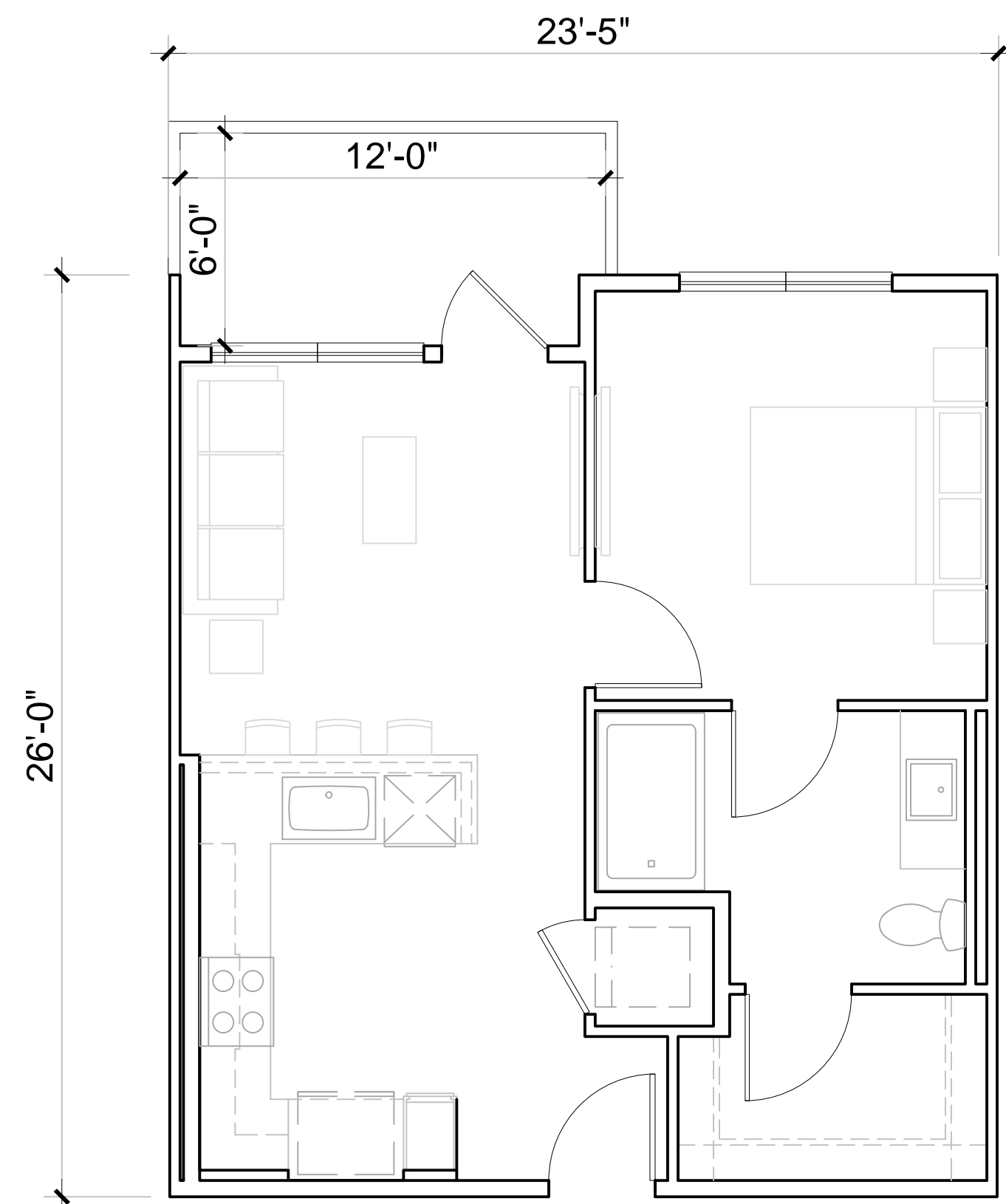

PLAN A2
1 BEDROOM
1 BATH
585 SF

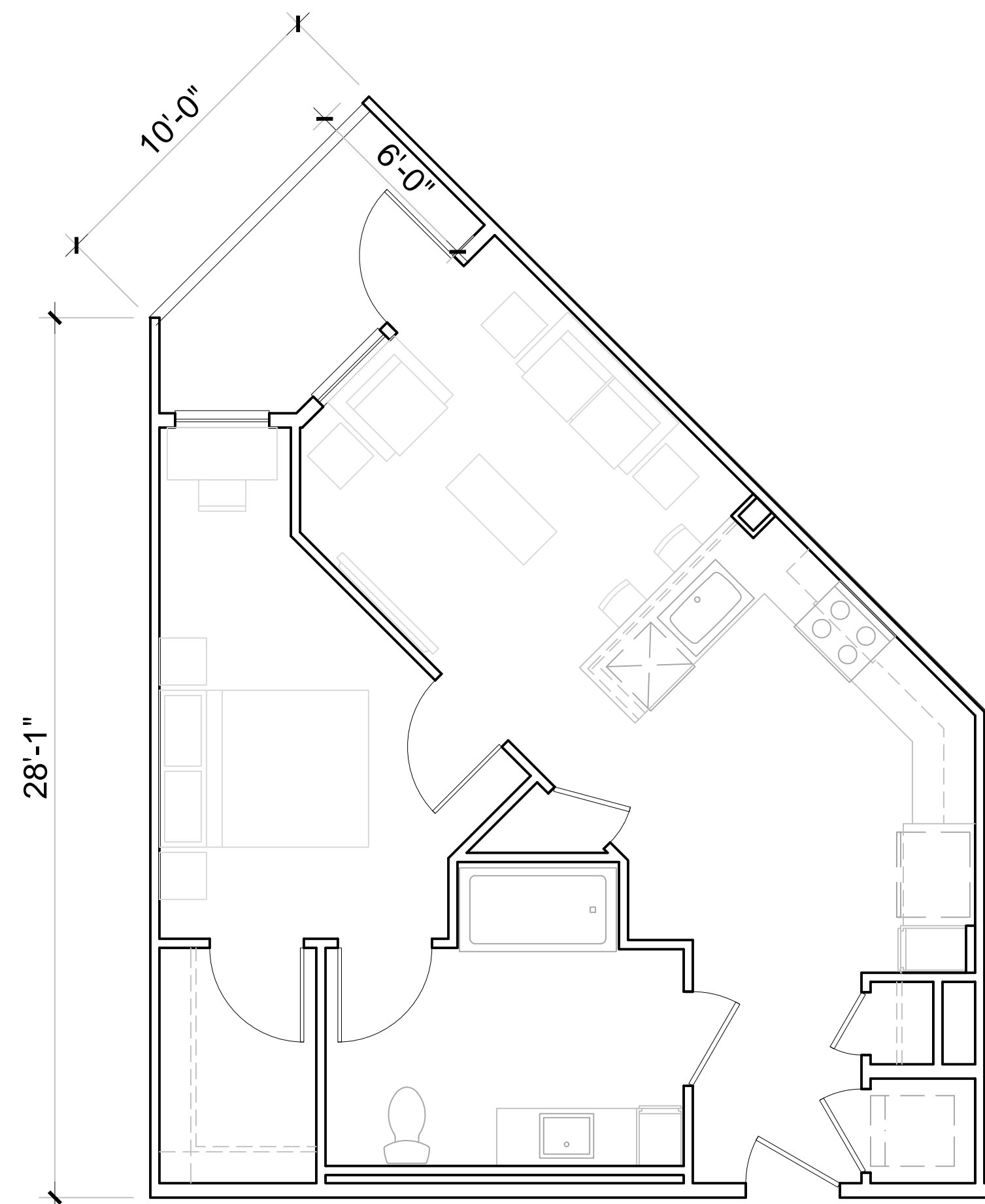

PLAN A3
1 BEDROOM
1 BATH
660 SF

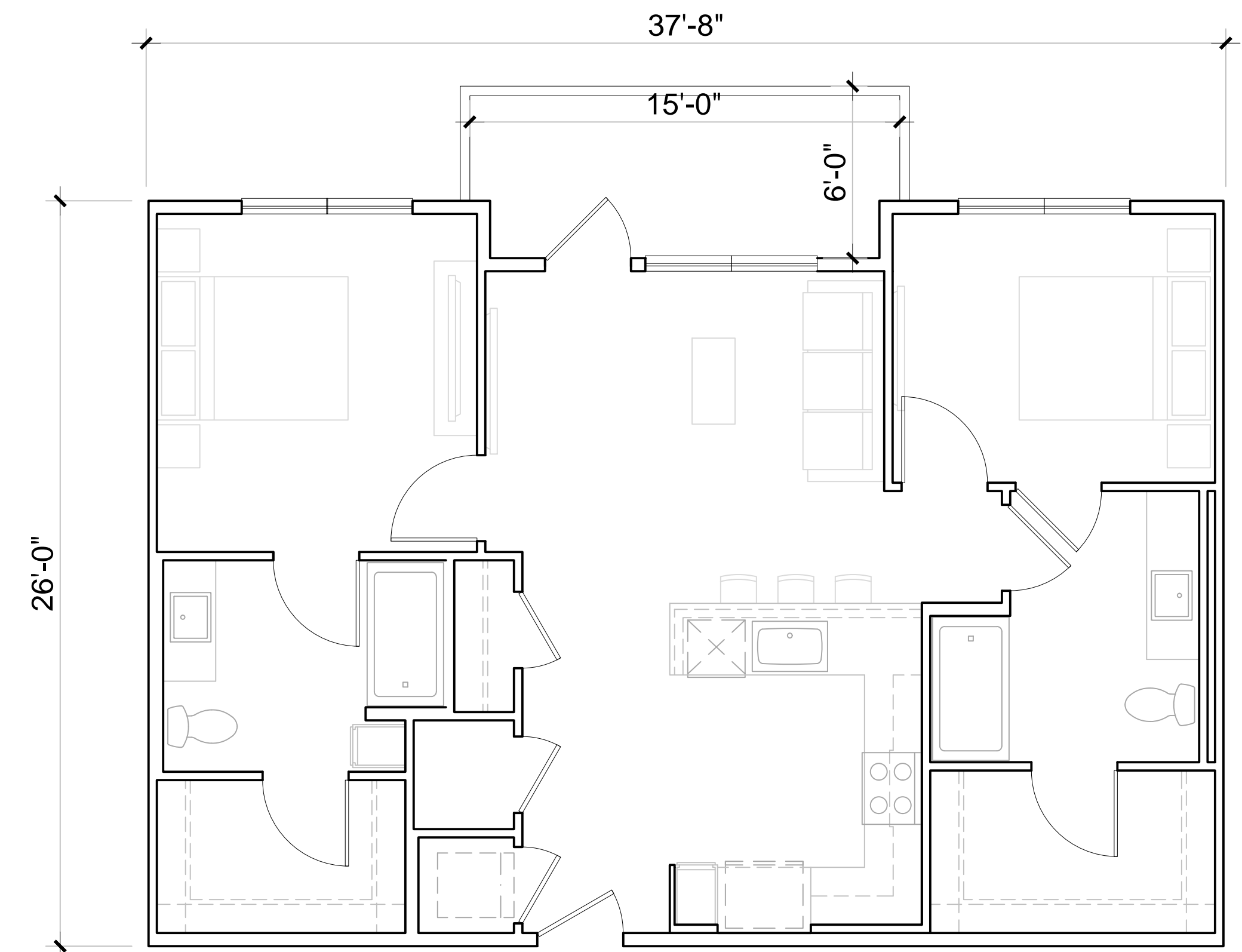

PLAN B1
2 BEDROOM
2 BATH
952 SF

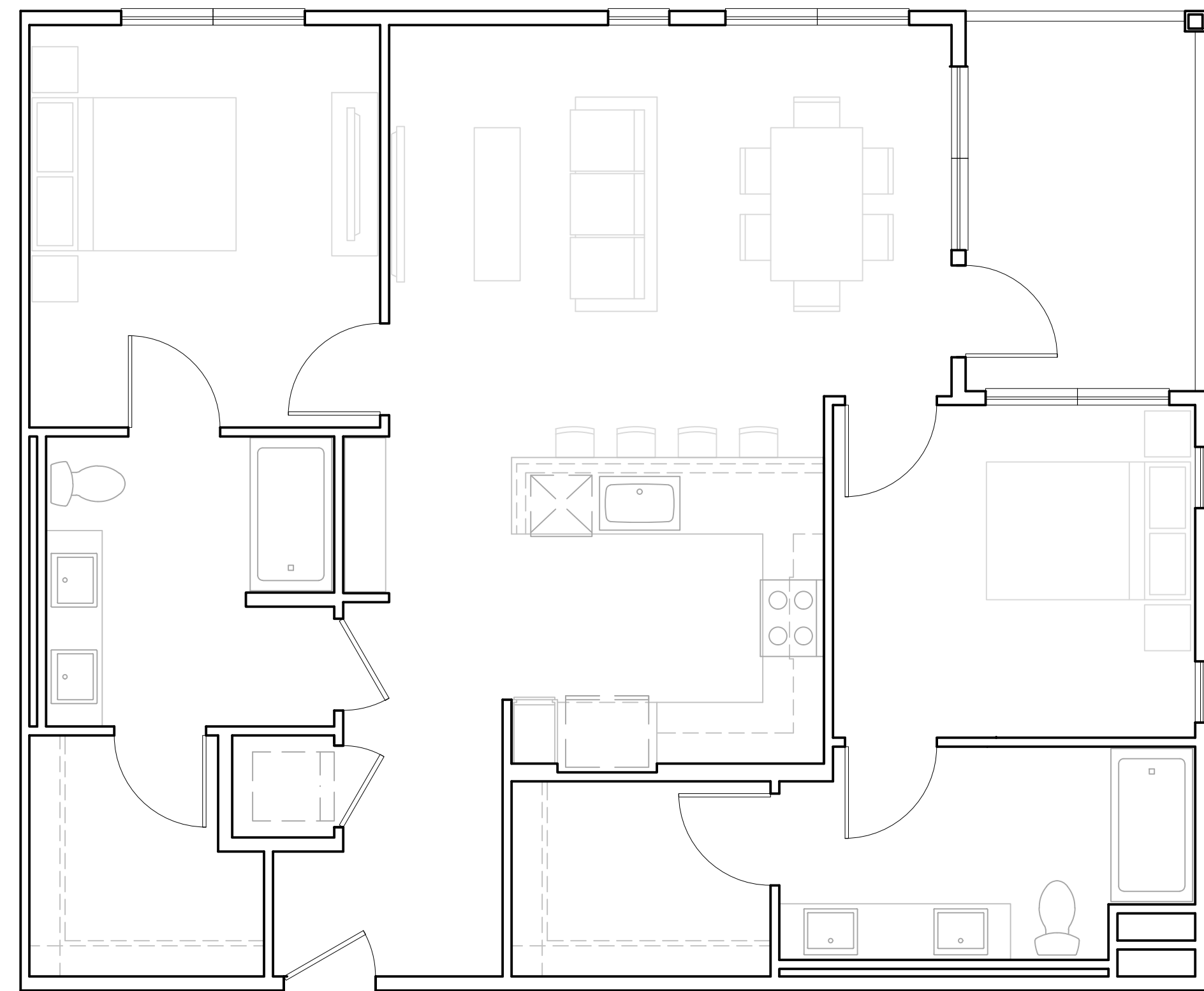

PLAN B3
 2 BEDROOM
 2 BATH
 1,145 SF

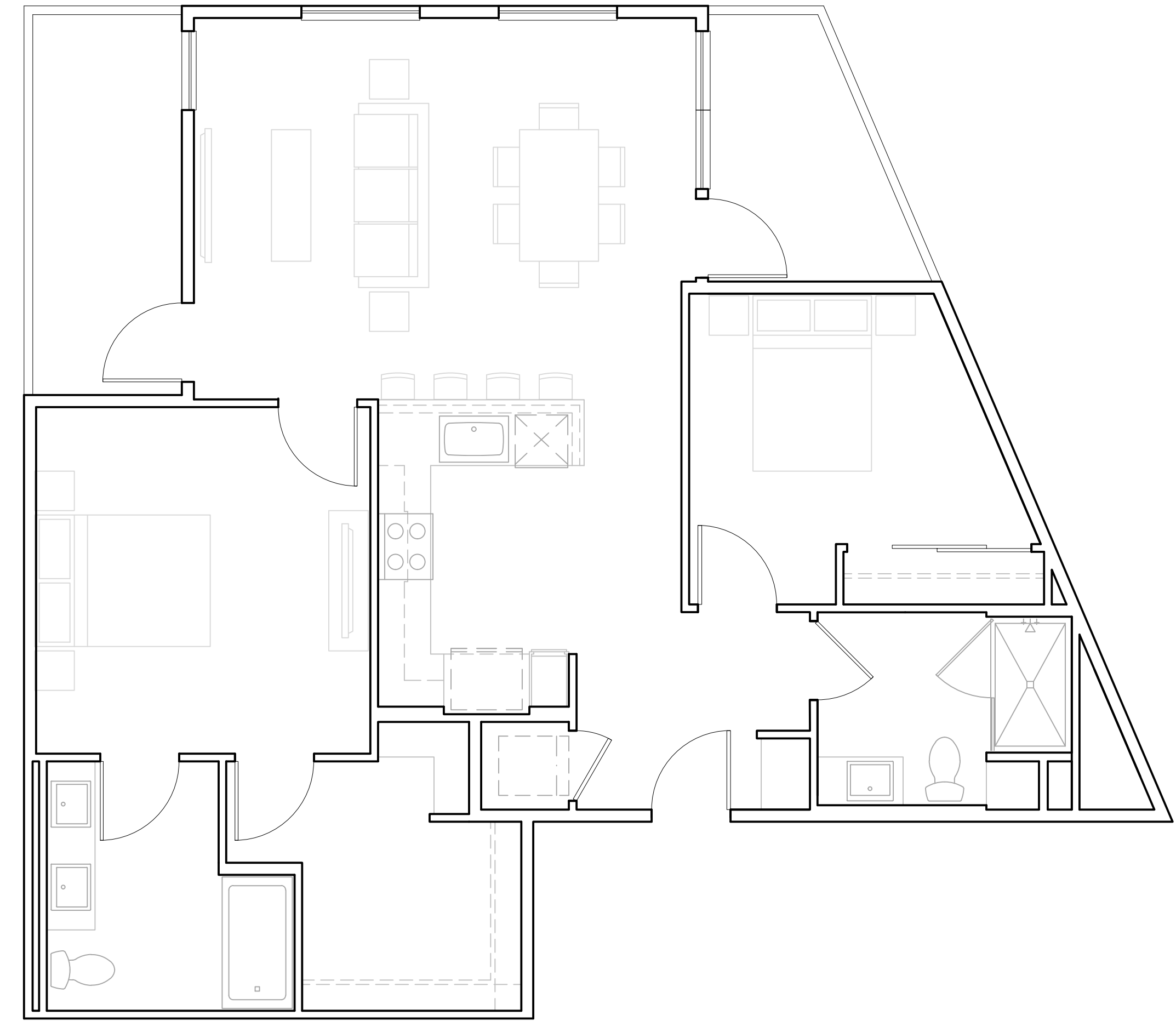

PLAN B3-ALT
 2 BEDROOM
 2 BATH
 1,138 SF



A. SOUTH-EAST AERIAL PERSPECTIVE



Architecture + Planning
888.456.5849
ktgy.com

Grubb
4601 Park Road, Suite 450
Charlotte, NC 28209

1200 VINE STREET
LOS ANGELES, CA # 2021-1034

CONCEPTUAL DESIGN
JULY 26, 2022

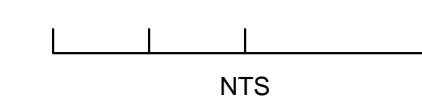

CONCEPTUAL PERSPECTIVES

A6-0



B. NORTH-WEST AERIAL PERSPECTIVE



Architecture + Planning
888.456.5849
ktgy.com

Grubb
4601 Park Road, Suite 450
Charlotte, NC 28209

1200 VINE STREET
LOS ANGELES, CA # 2021-1034

CONCEPTUAL DESIGN
JULY 26, 2022

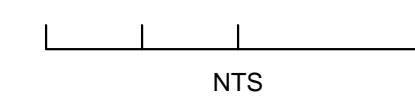

CONCEPTUAL PERSPECTIVES

A6-1



COMPOSITE LANDSCAPE PLAN

LANDSCAPE DATA

LANDSCAPE AREA	PROVIDED	HYDROZONE AREA	PROVIDED
Level 1	3213 SF	Very Low	895 SF
Level 3 Podium	2129 SF	Low	3875 SF
Level 7	619 SF	Moderate	1191 SF
Total	5961 SF	Total	5961 SF

EXTERIOR COMMON OPEN SPACE	PROVIDED	REQUIRED LANDSCAPE (25%)	PROPOSED LANDSCAPE
Level 1 Plaza	1200 SF	300 SF	394 SF
Level 3 Podium Courtyard	5970 SF	1493 SF	2129 SF
Level 7 Roof Deck A	1200 SF	300 SF	355 SF
Level 7 Roof Deck B	620 SF	155 SF	264 SF
Total	8990 SF	2248 SF	3142 SF

TREE COUNT	PROVIDED	REQUIRED
Level 1	5	TOTAL UNITS: 151 REQUIRED: (1) 24" BOX MIN. PER 4 UNITS
Level 3 Podium	25	
Level 7	8	
Total	38	38



LEGEND

- 1 Entry Plaza
- 2 Bench
- 3 Planters
- 4 Decorative Pottery
- 5 Dog Run
- 6 Maintenance Path
- 7 Existing Street Trees
- 8 Streetscape per City Standards
- 9 Inner Garden Planting
- 10 Wood Screen with Vines



Architecture + Planning
888.456.5849
ktgy.com

B Landscape Architecture
213.372.5111
border-la.com

Grubb
4601 Park Road, Suite 450
Charlotte, NC 28209

1200 VINE STREET
LOS ANGELES, CA #2021-1034

CONCEPTUAL DESIGN
SEPTEMBER 16, 2022



LANDSCAPE PLAN
LEVEL 1

L1-1



LEGEND

- ① Pool
- ② Flush Planter
- ③ Pool Deck
- ④ Decorative Pottery
- ⑤ Live Roof Planting
- ⑥ Lawn
- ⑦ Fitness Spillout Space
- ⑧ Juice Bar/Countertop
- ⑨ Outdoor Kitchen
- ⑩ Fire Feature
- ⑪ Cabana Rooms
- ⑫ Garden Screens
- ⑬ Seating Gardens



LEGEND

- 1 Fiberglass Planters
- 2 Live Roof Planting
- 3 Yoga/Sun Deck
- 4 Fire Feature
- 5 Stepping Stones
- 6 Trellis
- 7 Amenity Room Spillover Space
- 8 Outdoor Kitchen
- 9 Decorative Gravel
- 10 Countertop w/ Bar Seating
- 11 Decorative Pottery



Architecture + Planning
888.456.5849
ktgy.com

B Landscape Architecture
213.372.5111
border-la.com

Grubb
4601 Park Road, Suite 450
Charlotte, NC 28209

1200 VINE STREET
LOS ANGELES, CA #2021-1034

CONCEPTUAL DESIGN
SEPTEMBER 16, 2022



LANDSCAPE PLAN
LEVEL 7

L1-3

HARDSCAPE PALETTE

PAVING | GROUND LEVEL



Integral Color Concrete | Trademark
Color: Mesa Sand
Finish: Ecocast #5

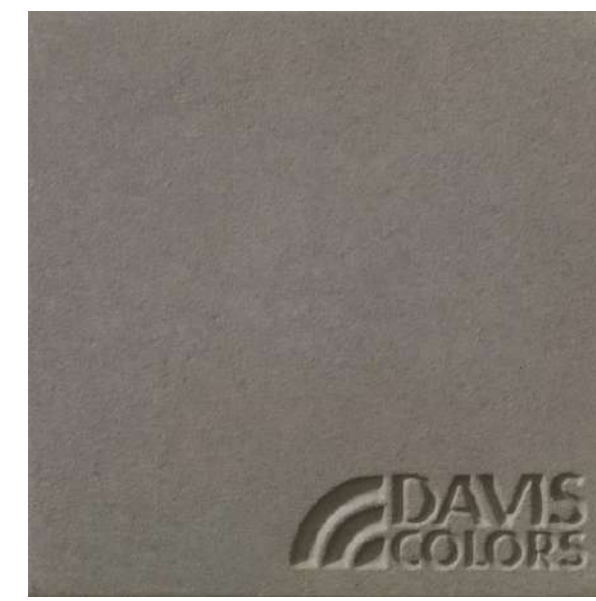

Integral Color Concrete | Davis
Color: Dune
Finish: Sandblast



Precast Concrete Paver | Stepstone
Color: Porcelain
Finish: Medium Sandblast w/Slag



Decomposed Granite | Southwest
Color: Desert Gold

PAVING | PODIUM AND ROOF LEVELS



Integral Color Concrete | Trademark
Color: Mesa Sand
Finish: Ecocast #5

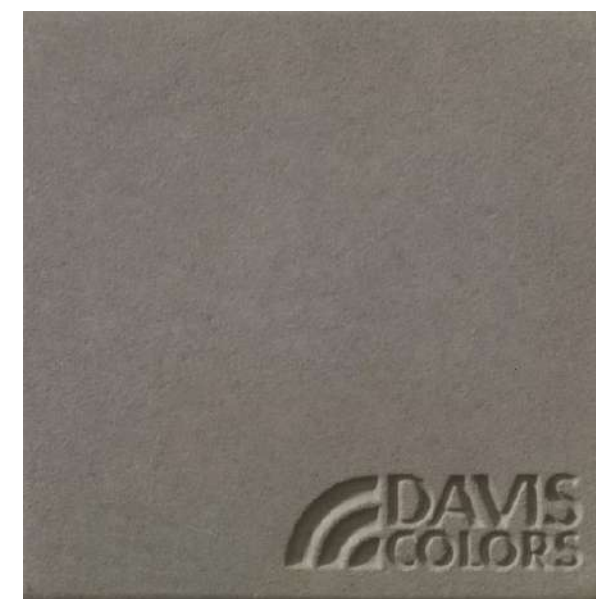

Integral Color Concrete | Davis
Color: Dune
Finish: Sandblast



Porcelain Tile | Belgard
Color: Jurupa - Camp
Finish: N/A



Porcelain Tile | Belgard
Color: Lagoon - Atmosphere
Finish: N/A

WALLS + POTTERY



CMU Planter | Orco
Color: Tan
Finish: Precision

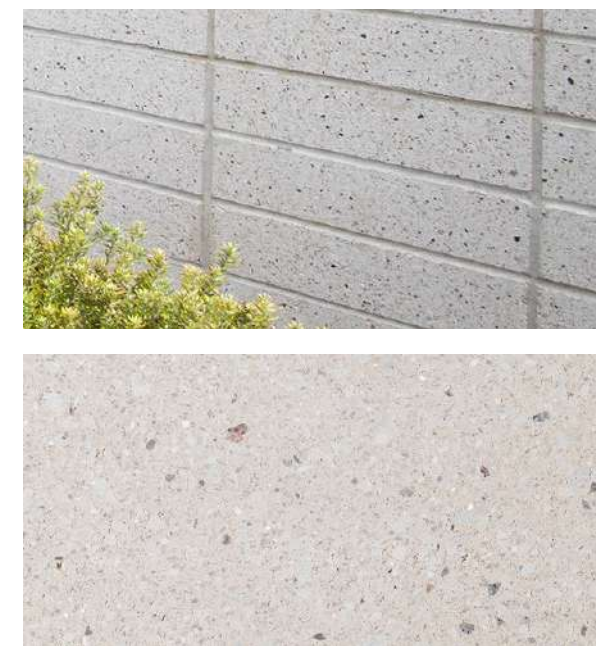

CMU Planter | Orco
Color: White
Finish: Burnished



Steel Planter
Color: Bronze
Finish: Matte



CMU to Steel Planter Connection



Fiberglass Pottery | Old Town Fiberglass
Color: Venetian and River Gold
Finish: Matte



Concrete Pottery | Kornegay
Color: Sandstone
Finish: Sandblast

PLANT PALETTE

TREES

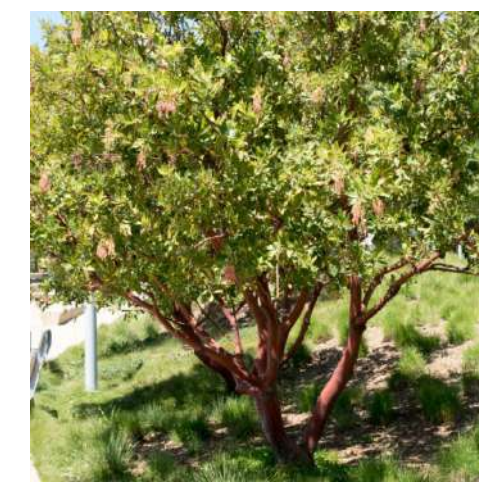

Arbutus 'Marina'
Strawberry Tree



Agonis flexuosa 'Burgundy'
Burgundy Peppermint Willow



Chilopsis linearis
Desert Willow



Dracaena draco
Dragon Tree



Ulmus parvifolia 'Drake'
Drake Elm

SHRUBS



Acacia cognata 'Cousin Itt'
Cousin Itt Acacia



Aloe vera
NCN



Dianella caerulea 'Cassa Blue'
Cassa Blue Flax Lily



Echium candicans
Pride of Madeira



Epilobium canum
California Fuchsia



Euphorbia characias 'Glacier'
Glacier Blue Spurge



Fejoia sellowiana
Pineapple Guava



Kalanchoe beharensis
Velvet Elephant Ear



Leonotis leonurus
Lion's Ear



Mahonia eurybracteata 'Soft Caress'
Soft Caress Mahonia



Miscanthus sinensis 'Adagio'
Adagio Maiden Grass



Olea europaea 'Little Ollie'
Little Ollie Olive



Salvia chamaedryoides
Germander Sage



Salvia clevelandii
Cleveland Sage



Westringia fruticosa 'Morning Light'
Morning Light Coast Rosemary



Yucca whipplei
Out Lord's Candle

PLANTING LEGEND

BOTANICAL NAME	COMMON NAME	SIZE (HxW)	WUCOLS
<i>Acacia baileyana</i>	Bailey Acacia	25' x 30'	Low
<i>Agonis flexuosa 'Burgundy'</i>	Burgundy Peppermint Willow	20' x 15'	Low
<i>Chilopsis linearis</i>	Desert Willow	20' x 15'	Very Low
<i>Phoenix dactylifera</i>	Date Palm	50' x 20'	Low
<i>Ulmus parvifolia 'Drake'</i>	Drake Elm	40' x 35'	Moderate
<i>Acacia cognata 'Cousin Itt'</i>	Cousin Itt Acacia	3' x 12'	Moderate
<i>Aloe vera</i>	NCN	2' x 2'	Low
<i>Dianella caerulea 'Cassa Blue'</i>	Cassa Blue Flax Lily	2' x 2'	Moderate
<i>Echium candicans</i>	Pride of Madeira	5' x 5'	Low
<i>Epilobium canum</i>	California Fuchsia	2' x 4'	Very Low
<i>Euphorbia characias 'Glacier Blue'</i>	Glacier Blue Spurge	2' x 2'	Very Low
<i>Fejoia sellowiana</i>	Pineapple Guava	10' x 10'	Low
<i>Kalanchoe beharensis</i>	Velvet Elephant Ear	10' x 6'	Low
<i>Leonotis leonurus</i>	Lion's Ear	5' x 5'	Low
<i>Mahonia eurybracteata 'Soft Caress'</i>	Soft Caress Mahonia	3' x 3'	Moderate
<i>Miscanthus sinensis 'Adagio'</i>	Adagio Maiden Grass	2' x 3'	Moderate
<i>Olea europaea 'Little Ollie'</i>	Little Ollie Olive	5' x 4'	Low
<i>Salvia chamaedryoides</i>	Germander Sage	2' x 4'	Low
<i>Salvia clevelandii</i>	Cleveland Sage	4' x 4'	Low
<i>Westringia fruticosa 'Morning Light'</i>	Morning Light Coast Rosemary	3' x 3'	Low
<i>Yucca whipplei</i>	Our Lord's Candle	2' x 3'	Very Low
<i>Bouteloua gracilis 'Blonde Ambition'</i>	Blonde Ambition Blue Grama	1' x 1'	Low
<i>Juniperus conferta 'Blue Pacific'</i>	Blue Pacific Shore Juniper	1' x 6'	Low
<i>Sedum reflexum 'Blue Spruce'</i>	Blue Spruce Creeping Sedum	6' x 18"	Low
<i>Sesleria autumnalis</i>	Autumn Moor Grass	1'x1'	Moderate

GRASSES + GROUND COVER



Bouteloua gracilis 'Blonde Ambition'
Blonde Ambition Blue Grama



Juniperus conferta 'Blue Pacific'
Blue Pacific Shore Juniper



Sedum reflexum 'Blue Spruce'
Blue Spruce Creeping Sedum



Sesleria autumnalis
Autumn Moor Grass

Consulting Arborist's Report

Tree Evaluation Report

For: 1200 Vine Street, Los Angeles, Apartments

Prepared for: 1200 Vine Street, Los Angeles Apartments, LLC
c/o Ms. Megan Watson
Grubb Properties
4601 Park Road, Suite 450
Charlotte, NC 28209

Prepared by: Arborgate Consulting, Inc.
Greg Applegate, ASCA, ASLA
1131 Lucinda Way
Tustin, CA 92780
714/ 731-6240

Dated: 6/21/2022

Table of Contents

INTRODUCTION	1
BACKGROUND.....	1
SCOPE OF WORK	1
TREE MAP.....	2
OBSERVATIONS	3
GENERAL FINDINGS	3
MATRIX OF FINDINGS.....	4
<i>Common abbreviations in the matrix above include:</i>	4
PHOTOGRAPHIC DOCUMENTATION	5
RECOMMENDATIONS	11
MATRIX OF RECOMMENDATIONS	11
TESTING & EVALUATION	12
VISUAL ANALYSIS OF TREE CONDITION	12
ASSUMPTIONS AND LIMITING CONDITIONS	13
APPENDIX	14
A. Resume	15
B. Glossary.....	16
DISCLAIMER	18
CERTIFICATION.....	19

Introduction

Background

Grubb Properties (Vine Street, Los Angeles Apartments) is planning to build an apartment complex at 1200 Vine Street, Los Angeles. The existing property there now is vacant and unused. The planned development will be a mixed-use project, with approximately 153 units and 8,000 square feet of commercial space. Three palms and nine street trees of reportable size are growing on this property. To properly grade, prepare the site, and build the proposed apartments will require the removal of the three palms.

Scope of Work

Arborgate Consulting was asked to submit a proposal for review and arboricultural evaluation of about 8 to 9 trees' and three palms' health and condition, professional opinions and report as appropriate for the City of Los Angeles, Urban Forestry Division. Each tree are to be photographed, measured and evaluated. Recommendations are to be provided for removal or retention and measures to preserve any suitable trees.

Tree Map

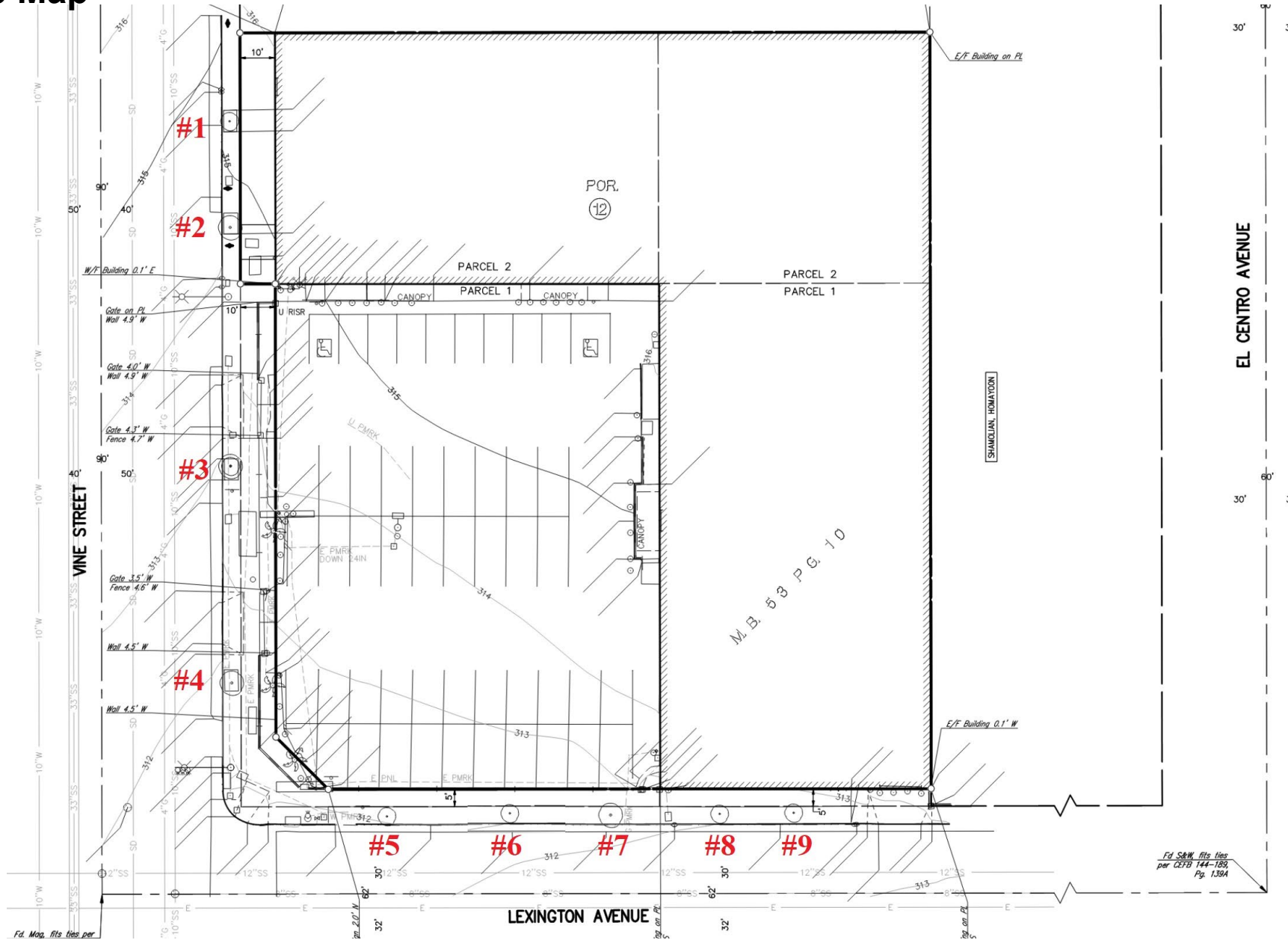

Observations

General Findings

The 1200 Vine Street Apartments will be located on the southeast corner of a busy street, Vine Street and Lexington. The site is relatively level. Most of the site soil is sterile and compacted due to decades of paving and structural cover. The only “trees” on site are three Mexican fan palms, in a planter at the front edge of the property in the southwest corner of the site. None of the seven observed trees are considered protected under the City's Protected Tree and Shrub Ordinance, but all of the real woody trees are City street trees, Jacarandas and pink trumpet trees.

The jacarandas on Vine are in declining health from north to south. All four have poor structure except the fourth one, which is marginally fair. Street people are even using the space inside the tree wells, but more so on the north end.

The pink trumpet trees are in declining health and structure from west to the east. The fourth one (#8) is totally dead and looks burned. The last one (#9) is half dead, and looks burned on the west side. Details are in the matrix below.

Constructing a 153.-unit residential building with 8000 square feet of commercial space will of necessity require the removal of everything now on the site, including the palm trees, and possibly a few street trees, at least the dead or near dead ones. The Mexican fan palms are not of sufficient value to transplant. All the street trees are relatively young, but considering the small, four-foot-wide sidewalk cutouts, they will need to be replaced in a few years.

Matrix of Findings

Tag	Species	Common name	DBH	Ht.	Wd	Health	Structure	Space	Location	Comments
1	Jacaranda mimosifolia	Jacaranda	7	15	16	B	D	4x6'	Vine St	T-bow CrS Xing brk TO
2	Jacaranda mimosifolia	Jacaranda	8	20	18	C	D	4x6'	Vine St	Cod SS mDb epi
3	Jacaranda mimosifolia	Jacaranda	4.8	16	18	D	D	4x6'	Vine St	Cod Xing Db TO epi S/W damage
4	Jacaranda mimosifolia	Jacaranda	7	18	24	B	C-	4x6'	Vine St	Cod inc epi
5	Handroanthus impetiginosus	Pink trumpet tree	7.2	25	25	A	B	4' pkwy	Lexington	Small break
6	Handroanthus impetiginosus	Pink trumpet tree	2.1	13	11	B	C-	4' pkwy	Lexington	Low epi, still staked
7	Handroanthus impetiginosus	Pink trumpet tree	7.8	24	30	B	C-	4' pkwy	Lexington	Cod inc TO
8	Handroanthus impetiginosus	Pink trumpet tree	4	18	24	F	F	4' pkwy	Lexington	Dead cod brk NoRF, burned
9	Handroanthus impetiginosus	Pink trumpet tree	6.2	18	20	D	D	4' pkwy	Lexington	1/2 dead & burned. Cod inc
10	Washingtonia robusta	Mexican fan palm	60'th	60'th	11	B	A	Planter	on site	good, small skirt
11	Washingtonia robusta	Mexican fan palm	60'th	60'th	11	B	A	Planter	on site	good, small skirt
12	Washingtonia robusta	Mexican fan palm	60'th	60'th	11	B	A	Planter	on site	good, small skirt

Common abbreviations in the matrix above include:

Brk = broken

Cod=codominant

Cr=crowding or crowded

Db = dieback

DBH – Diameter at breast height, i.e. 4.5'

Dk=decayed

epi = epicormic shoots

Gird = girdling

Hd = headed

Inc=included bark

NoRF = no root flare

Pkwy = parkway

SW=sidewalk

SS = sun-scald

T-bow = bowed trunk

TO – tear out

Ts = trunks

Xing = crossing branches

Photographic Documentation



#1 Jacaranda. Later there was a barbeque in the tree well.



#2 Jacaranda. The main crotch is weak.

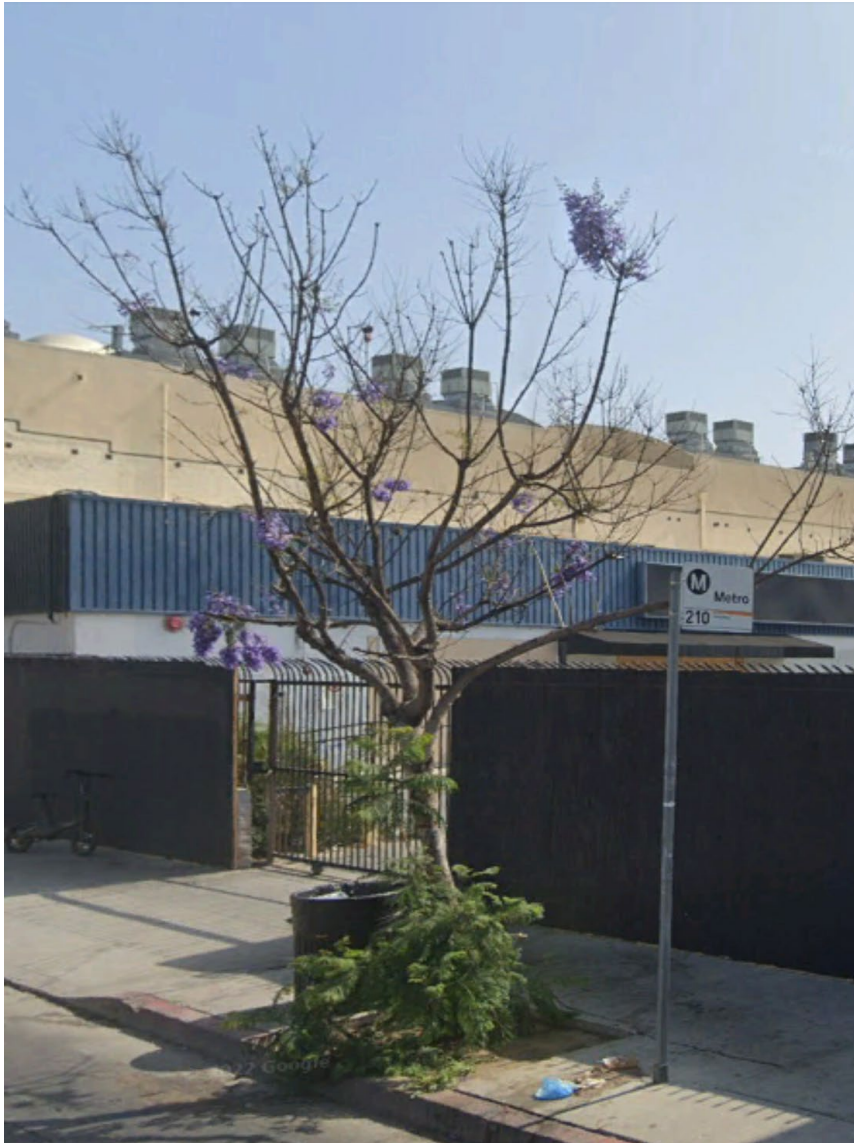

#3 Jacaranda. Note the crowded limbs and damaged trunk.



#4 Jacaranda. Awkward branching and the main crotch is weak



#5 Pink trumpet tree- is a good specimen, worthy of preservation.

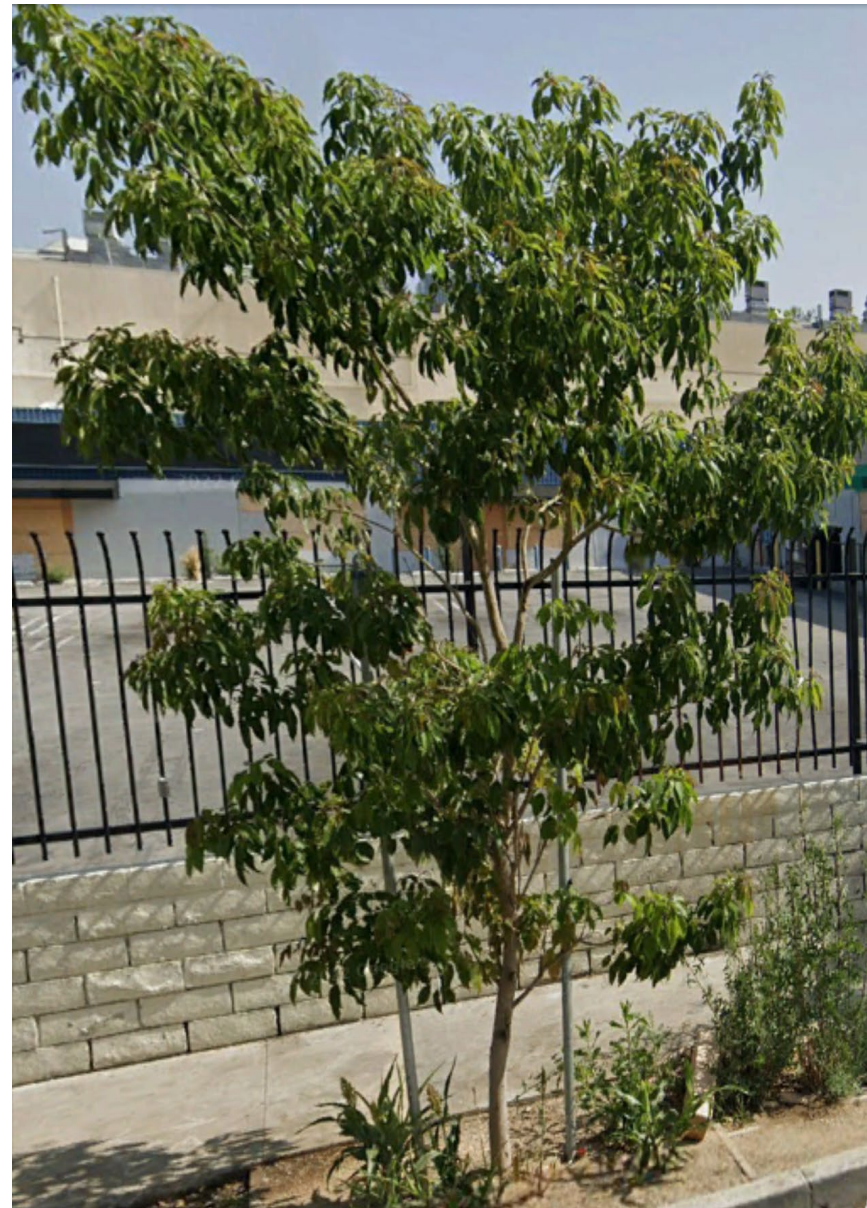

#6 Trumpet tree is not getting the training it needs.



#7 Pink trumpet tree is healthy, but codominant and a limb tore out.



#8 Pink trumpet tree-is dead. Bark is falling off and looks burned.



#9 Trumpet tree, this side is nearly dead. Note bark is peeling.



#10,11 and 12 Mexican fan palms (L-R)

Recommendations

Matrix of Recommendations

Tag	Species	Common name	DBH	Ht.	Wd.	Health	Structure	Recommendations
1	Jacaranda mimosifolia	Jacaranda	7	15	16	B	D	Remove and replace
2	Jacaranda mimosifolia	Jacaranda	8	20	18	C	D	Remove and replace
3	Jacaranda mimosifolia	Jacaranda	4.8	16	18	D	D	Remove and replace
4	Jacaranda mimosifolia	Jacaranda	7	18	24	B	C-	Protect in place
5	Handroanthus impetiginosus	Pink trumpet tree	7.2	25	25	A	B	Protect in place
6	Handroanthus impetiginosus	Pink trumpet tree	2.1	13	11	B	C-	Train up as standard
7	Handroanthus impetiginosus	Pink trumpet tree	7.8	24	30	B	C-	Protect in place
8	Handroanthus impetiginosus	Pink trumpet tree	4	18	24	F	F	Remove and replace
9	Handroanthus impetiginosus	Pink trumpet tree	6.2	18	20	D	D	Remove and replace
10	Washingtonia robusta	Mexican fan palm	60'th	60'th	11	B	A	Remove
11	Washingtonia robusta	Mexican fan palm	60'th	60'th	11	B	A	Remove
12	Washingtonia robusta	Mexican fan palm	60'th	60'th	11	B	A	Remove

Testing & Evaluation

Visual Analysis of Tree Condition

All the subject trees were evaluated for condition of the trunk, its lean, scaffold limbs, secondary branching, foliage density, and root crown condition. The root crown was examined, as far as it was visible, without excavation.

The health was evaluated on a visual basis. If there were no nutrient deficiency symptoms, the foliage was full and dense, there were few dead twigs or limbs, and there were no pest or disease symptoms, it was assumed that they were healthy. To the degree that symptoms or problems existed, the trees were rated for health on a five-point scale (A to F, F being dead).

The structural condition, i.e. trunk, scaffold limbs and branches were evaluated on a similar five point scale. Likewise, the best structural condition is termed “A“ or excellent. If there were only a couple minor problems or defects, the condition is called “B“ or good. If the structure was such that the tree was not in jeopardy, but it was not good, the condition is called “C “ or fair. If the tree was at risk of some sort of failure, but might be corrected, the structural condition is called “D“ or poor. “F” is dead or dangerous.

The trunk diameters were measured with calipers. The measurements were taken at 4.5 feet (DBH) to be in conformity with industry standards. If a tree branched low and the narrowest point of the trunk was below 4.5 feet, the diameter was measured there, i.e., at the narrowest point.

Assumptions and Limiting Conditions

1. Any legal description provided to this consultant is assumed to be correct. Any titles and ownerships to any property are assumed to be good and marketable. No responsibility is assumed for matters legal in nature.
2. It is assumed that any property is not in violation of any applicable codes, ordinances, statutes, or other governmental regulations.
3. Care has been taken to obtain as much information as possible from reliable sources. Data has been verified insofar as possible. However, the consultant can neither guarantee nor be responsible for the accuracy of information provided by others.
4. This consultant shall not be required to give testimony or attend court by reason of this report unless subsequent contractual arrangements are made, including payment of an additional fee for such services as described in the fee schedule or contract of engagement.
5. Unless required by law otherwise, possession of this report or a copy thereof does not imply right of publication or use for any purpose by any other than the person and project to whom it is addressed, without the prior expressed written or verbal consent of this consultant.
6. Unless required by law otherwise, neither all nor any part of this report or a copy thereof, shall be conveyed by anyone, including the client, to the public through advertising, public relations, news, sales or other media without the prior expressed written consent of this consultant - particularly as to the identity of the consultant, or any reference to any professional society or institute or to any initialed designation conferred upon this consultant as stated in his qualifications.
7. This report and any values expressed herein represent the opinion of this consultant, and this consultant's fee is in no way contingent upon the reporting of a stipulated result, the occurrence of a subsequent event, nor upon any finding to be reported.
8. Sketches, drawings, and photographs in this report, being intended as visual aids, are not necessarily to scale and should not be construed as engineering or architectural reports or surveys unless expressed otherwise. The reproduction of any information generated by architects, engineers, or other consultants on any sketches, drawings, or photographs is for the express purposes of coordination and ease of reference only. Inclusion of said information on any drawings or other documents does not constitute a representation by Greg Applegate as to the sufficiency or accuracy of said information.
9. Unless expressed otherwise: 1) information contained in this report covers only those items that were examined and reflects the condition of those items at the time of inspection; conditions change and monitoring is needed to stay abreast of these changes, and 2) the inspection is limited to visual examination of accessible items without dissection, excavation, probing, or coring.
10. This report is the completed work product. Any additional work, including, e.g. production of a site plan, addenda and revisions, monitoring, or inspection of tree protection measures, must be contracted separately.
11. Use of the report is dependent upon payment and non payment voids all legal use of the report. Ownership of any documents produced passes to the Client only when all fees have been paid.
12. Loss or alteration of any part of this report invalidates the entire report.

Appendix

A. Resume

B. Glossary

A. Resume

GREGORY W. APPEGATE, ASCA, ASLA emeritus

PROFESSIONAL REGISTRATIONS:

American Society of Consulting Arborists - Registered Consulting Arborist #365
American Society of Consulting Arborists – Tree & Plant Appraisal Qualified
International Society of Arboriculture - Tree Risk Assessment Qualified
International Society of Arboriculture - Certified Arborist # WE-180a

EXPERIENCE:

Mr. Applegate is an independent consulting arborist. He has been in the horticulture field since 1963, providing professional arboricultural consulting since 1984 within both private and public sectors. His expertise includes appraisal, tree preservation, diagnosis of tree growth problems, construction impact mitigation, environmental assessment, expert witness testimony, hazard evaluation, pruning programs, species selection and tree health monitoring.

Mr. Applegate has consulted for insurance companies, major developers, theme parks, homeowners, homeowners' associations, landscape architects, landscape contractors, property managers, attorneys and governmental bodies.

Notable projects on which he has consulted are: Disneyland, Disneyland Hotel, DisneySeas-Tokyo, Disney's Wild Animal Kingdom, the New Tomorrowland, Disney's California Adventure, Disney Hong Kong project, Knott's Berry Farm, J. Paul Getty Museum, Tustin Ranch, Newport Coast, Crystal Court, Newport Fashion Island Palms, Bixby Ranch Country Club, Playa Vista, Laguna Canyon Road and Myford Road for The Irvine Company, MTA Expo Line, MWD-California Lakes, Paseo Westpark Palms, Loyola-Marymount campus, Cal Tech, Cal State Long Beach, Pierce College, The Irvine Concourse, UCI, USC, UCLA, LA City College, LA Trade Tech, Riverside City College, Crafton Hills College, MTA projects, and the State of California review of the Landscape Architecture License exam (re: plant materials)

EDUCATION:

Bachelor of Science in Landscape Architecture, California State Polytechnic University, Pomona 1973
Arboricultural Consulting Academy (by ASCA) Arbor-Day Farm, Kansas City 1995
Continuing Education Courses in Arboriculture, required to maintain Certified Arborist status and for ASCA membership

PROFESSIONAL AFFILIATIONS:

American Society of Consulting Arborists (ASCA), Registered member
International Palm Society, Full member
International Society of Arboriculture (ISA), Certified member
California Tree Failure Report Program, UC Davis, Participant
Street Tree Seminar (STS), Member

COMMUNITY AFFILIATIONS:

Horticulture Advisory Committee, Saddleback College (1988 -1999)
Landscape Architecture License Exam, Reviewer, Cal Poly Pomona (1986-90)
American Institute of Landscape Architects (L.A.) Board of Directors (1980-82)
California Landscape Architect Student Scholarship Fund - Chairman (1985)
International Society of Arboriculture - Examiner-tree worker certification (1990)
Guest lecturer at UCLA, Cal Poly, Saddleback College, & Palomar Junior College
ASCA 2011 Nominations Committee and A3G appraisal update committee
ASCA, Industry definitions committee 2009-2010
ASCA web site, west coast tree question responder (2007-2016)

B. Glossary

ANSI-A300	American National Standards Institute performance standards for the care and maintenance of trees, shrubs and other woody plants. Consists of nine parts in separate documents. Part 1 covers pruning.
Arboriculture	The cultivation and care of trees and shrubs.
Arborist	professional who possesses the technical competence gained through experience and related training to provide for or supervise the management of trees and other woody plants in residential, commercial or public settings.
Caliper	Diameter of a tree trunk. Larger trees are usually measured at 4½ feet (see DBH) Trees with calipers 4 inches and below are measured at 6 inches above grade. Trees above 4 inches, but still transplantable are measured at 12 inches above grade.
Codominant	stems: two or more vigorous and upright branches of relatively equal size that originate from a common point, usually where the leader has been lost or removed.
Compaction	(Soil Compaction) The compression of soil, causing a reduction of pore space and an increase in the density of the soil. Tree roots cannot grow in compacted soil.
Conifer-	A gymnosperm which bears cones, such as pine or fir, but sometimes another of the Coniferae group which does not produce cones, such as Gingko.
Crotch	The union of two or more branches; the axillary zone between branches.
Crown	The upper portions of a tree or shrub, including the main limbs, branches, and twigs.
Crown restoration	method of restoring the natural growth habit of a tree that has been topped or damaged in any other way. Aka Restoration pruning.
DBH	Diameter of the trunk, measured at breast height or 54 inches above the average grade. Syn. = caliper.
Decline	Progressive reduction of health or vigor of a plant.
Dieback	Progressive death of buds, twigs and branch tissues, on individual limbs, or throughout the canopy.
Epicormic	Epi - upon; cormic – stem. Branches that are upon the stem, i.e. sprouting from either dormant buds in the cambial zone, or from buds sprung anew from ray traces. Epicormic shoots are a sign that energy reserves have been lowered.

Grading	Also Regrading. Intentional altering of topography and soil levels, using machinery.
Hazardous condition	The combination of a likely failure of a tree or tree part with the presence of a likely target.
Heading	Pruning techniques where the cut is made to a bud, weak lateral branch or stub.
Included bark	Bark or cortex tissue that is included or trapped between close-growing branches. Usually found in narrow or tight crotches.
Limb	A large lateral branch growing from the main trunk.
Palm	A tropical or subtropical monocotyledonous tree or shrub, usually having a woody, unbranched trunk and large, evergreen, fan or feather-shaped leaves at the top.
Root crown	Area at the base of a tree where the roots and stem merge (synonym - root collar).
Root system	The portion of the tree containing the root organs, including buttress roots, transport roots, and fine absorbing roots; all underground parts of the tree.
Root zone	The area and volume of soil around the tree in which roots are normally found. May extend to three or more times the branch spread of the tree, or several times the height of the tree.
Stress	"Stress is a potentially injurious, reversible condition, caused by energy drain, disruption, or blockage, or by life processes operating near the limits for which they were genetically programmed." Alex Shigo
Value	Value is the present worth of future benefits. Value is not necessarily cost.
Wound	Any injury which induces a compartmentalization response.

Disclaimer

Good current information on tree preservation has been applied. However, even when every limb and root is inspected, inspection involves sampling, therefore some areas of decay or weakness may be missed. Weather, winds and the magnitude and direction of storms are not predictable and some failures may still occur despite the best application of high professional standards. Future tree maintenance will also affect the trees health and stability and is not under the supervision or scrutiny of this consultant. Continuing construction activity such as trenching will also affect the health and safety, but are unknown and unsupervised by this consultant. Trees are living, dynamic organisms and their future status cannot be predicted with complete certainty by any expert. This consultant does not assume liability for any tree failures involved with this property.

Certification

I, Gregory W. Applegate, certify to the best of my knowledge and belief:

That the statements of fact contained in this report are true and correct. That the report analysis, opinions, and conclusions are limited only by the reported assumptions and limiting conditions, and are my personal unbiased professional analysis, opinions and conclusions.

That I have no present or prospective interest in the vegetation that is the subject of this report, and I have no personal interest or bias with respect to the parties involved.

That my compensation is not contingent upon the reporting of a predetermined conclusion, that favors the cause of the client, the attainment of stipulated result or the occurrence of a subsequent event.

That my analysis, opinions, and conclusions were developed, and this report has been prepared, in conformity with the standards of arboricultural practice. As of this report date, I have completed the requirements of continuing education for Registered Consulting Arborist.

That my opinions are based on the information known to me at this time. No internal dissection or decay investigation was made.

That I have made a personal inspection of the trees that are the subject of this report. No one provided significant professional assistance to the person signing this report.

Furthermore, the opinions above are held with reasonable degree of professional certainty, predicated on over 50 years of experience in the nursery, landscape, and arboricultural industries and the documents and information provided me.

I do not authorize out of context quoting from or partial reprinting of this appraisal report. Neither all or any part of this report shall be disseminated to the general public by the use of media for public communication without the prior written consent of the undersigned.

Arborgate Consulting, Inc.

Gregory W. Applegate _____

Registered Consulting Arborist #365

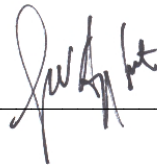

Date 06-21-22



MEMORANDUM

TO: Wes Pringle and Eileen Hunt, Los Angeles Department of Transportation

FROM: Emily Wong, P.E., and Lauren Mullarkey-Williams

DATE: November 2, 2022

RE: Transportation Assessment for the
1200 Vine Street Project
Los Angeles, California

Ref: J2013

This memorandum presents the transportation assessment for the proposed 1200 Vine Project (Project) located at 1200, 1204, 1214, and 1218 N. Vine Street and 6245 and 6247 W. Lexington Avenue (Project Site) within the *Hollywood Community Plan*¹ (Los Angeles Department of City Planning [LADCP], 1988) area of the City of Los Angeles, California (City). The methodology and base assumptions used in the analysis were established in conjunction with the Los Angeles Department of Transportation (LADOT).

The scope of assessment was developed in consultation with LADOT and is consistent with *Transportation Assessment Guidelines* (LADOT, August 2022) (TAG) and in compliance with the California Environmental Quality Act (CEQA) Guidelines (California Code of Regulations, Title 14, Section 15000 and following). The base assumptions and technical methodologies (i.e., trip generation, study locations, analysis methodology, etc.) were identified as part of the study approach and were outlined in a Memorandum of Understanding (MOU) that was reviewed and approved by LADOT in August 2022 and is provided in Attachment A.

PROJECT DESCRIPTION

The Project proposes to construct an eight-story mixed-use development consisting of 153 residential units, including 18 affordable housing units, and 7,000 square feet of commercial uses. Vehicular access to the Project Site would be provided via one shared commercial and residential driveway on Vine Street with right-turn ingress and egress only and one full access residential-only driveway on Lexington Avenue. Parking for the Project would be provided on-site within one ground level and one above-grade level. Short-term and long-term bicycle parking would be provided on the ground level of the Project.

¹ The City is currently in the process of updating the Hollywood Community Plan to guide development for the Hollywood area through Year 2040. *Hollywood Community Plan Update Draft Environmental Impact Report* (Terry A. Hayes Associates, Inc., November 2018) was released for public review in October 2019. On March 18, 2021, the City Planning Commission recommended approval of the Hollywood Community Plan with recommended changes, which were subsequently incorporated to the Plan Update and released in August 2021. The City is still in its final steps of the adoption process and formal adoption of the Hollywood Community Plan Update is anticipated in late Year 2022 or Year 2023.

Pedestrian and bicycle access to the Project would be provided via commercial entrances along Vine Street and a residential lobby along Lexington Avenue. The Project would also include an outdoor plaza with access along Lexington Avenue. The Project is anticipated to be completed in Year 2027. The conceptual Project site plan is provided in Figure 1.

PROJECT LOCATION

The Project Site, contained within a portion of Assessor Parcel Numbers 5534-002-023 and -018, is located in the Hollywood area of the City, within City Council District 13. As shown in Figure 2, the Project Site is bounded by office uses to the north, residential uses to the east, Lexington Avenue to the south, and Vine Street to the west. The Project is located approximately less than 1.00 miles south of the Hollywood Freeway (US 101). The Project Site is primarily served by Vine Street and Lexington Avenue.

The Project Site is located within 0.25 miles of a Major Transit Stop, which is defined in Section 21064.3 of the Public Resources Code (PRC) as an existing, under construction, or planned rail station or intersection of two or more bus routes with service intervals of 15 minutes or less during the morning and afternoon commuter peak periods. Therefore, the Project Site is located within a Transit Priority Area (TPA), which is defined in Section 21099(a) of the PRC as an area within 0.50 miles of a major transit stop that is existing or planned. Nearest to the Project Site, the intersection of Gower Street & Santa Monica Boulevard, located 1,250 feet southeast of the Project Site, qualifies as a Major Transit Stop. Additionally, the Project Site is served by numerous bus lines, primarily along Vine Street that are operated by the Los Angeles County Metropolitan Transportation Authority (Metro) and the LADOT Downtown Area Short Hop (DASH).

PROJECT CONTEXT

A comprehensive data collection effort was undertaken to develop a detailed description of existing and future conditions in the Study Area.

Study Area

The Study Area includes key intersections along Vine Street, as well as the transportation infrastructure described below. This Study Area was established in consultation with LADOT based on the following factors identified in the TAG:

1. Primary driveway(s)
2. Intersections at either end of the block on which the Project is located or up to 600 feet from the primary Project driveway(s)
3. Unsignalized intersections adjacent to the Project Site that are integral to the Project's site access and circulation plan
4. Signalized intersections in proximity to the Project Site where 100 or more Project trips would be added

The signalized study intersections of Vine Street & Fountain Avenue (Intersection #1) and Vine Street & Lexington Avenue (Intersection #2) were identified for detailed analysis during the MOU process:

Figure 3 illustrates the Study Area and the two study intersections. The existing lane configurations at the analyzed intersections are provided in Figure 4.

Existing Transportation Conditions

The analysis included an Existing Conditions assessment of the existing transportation infrastructure and conditions of the Study Area including freeway and street systems and transit service, as well as pedestrian and bicycle circulation, in Year 2022. An inventory of lane configurations, signal phasing, parking restrictions, etc., for the analyzed intersections was also conducted. Traffic count data is provided in Attachment B.

Existing Street System. The existing street system in the Study Area consists of a regional roadway system including arterials and local streets that provide regional, sub-regional, or local access and circulation to the Project. These transportation facilities generally provide two to four travel lanes and usually allow parking on one or both sides of the street. Typically, the speed limits range between 25 and 35 miles per hour (mph) on the streets and 55 mph on freeways.

Street classifications are designated in *Mobility Plan 2035, An Element of the General Plan* (LADCP, September 2016) (the Mobility Plan). The Mobility Plan defines specific street standards in an effort to provide an enhanced balance between traffic flow and other important street functions including transit routes and stops, pedestrian environments, bicycle routes, building design and site access, etc.

The following is a brief description of the roadways in the Study Area, including their classifications under the Mobility Plan:

- **Vine Street** – Vine Street is designated Avenue II that runs in the north-south direction and is located adjacent to the western boundary of the Project Site. It generally provides four travel lanes, two lanes in each direction, with a two-way left-turn median and left-turn lanes at major intersections. One-hour metered parking is generally available on both sides of the street south of Lexington Avenue, and two-hour metered parking is generally available on both sides of the street north of Lexington Avenue. Class III bicycle sharrows are provided on both sides of the street within the Study Area. Travel lanes are typically 11 feet wide, and the total paved width is approximately 70 feet wide.
- **Fountain Avenue** – Fountain Avenue is a designated Collector Street that runs in the east-west direction and is located north of the Project Site. It generally provides two travel lanes, one lane in each direction, with left-turn lanes at major intersections. Two-hour unmetered parking is generally available on both sides of the street east of Vine Street, and unmetered parking is generally provided on both sides of the street west of Vine Street. Class III bicycle sharrows are provided on both sides of the street within the Study Area. The total paved width of the street is approximately 45-55 feet wide east of Vine Street and 40 feet wide west of Vine Street.

Lexington Avenue – Lexington Avenue is a designated Local Street that runs in the east-west direction and is located adjacent to the southern boundary of the Project Site. It generally provides two travel lanes, one lane in each direction. Within the Study Area, unmetered parking is generally available on both sides of the street. The total paved width of the street is approximately 40 feet wide.

The existing intersection mobility facilities are shown in Figure 5 and the Mobility Plan street designations are shown in Figure 6.

Existing Pedestrian Facilities. The walkability of existing facilities is based on the availability of pedestrian routes necessary to accomplish daily tasks without the use of an automobile. These attributes are quantified by WalkScore.com and assigned a score out of 100 points. With the various commercial businesses, employment, entertainment, and cultural centers adjacent to residential neighborhoods, the walkability of the Study Area is approximately 96 points².

The sidewalks that serve as routes to the Project Site provide proper connectivity and adequate widths for a comfortable and safe pedestrian environment. The sidewalks provide connectivity to accessible crossings at signalized intersections within the Study Area. Both study intersections provide pedestrian access in the vicinity of the Project Site, with marked pedestrian crossings on all approaches, pedestrian phasing, and crosswalk striping. Vine Street & Fountain Avenue (Intersection #1) provides Americans with Disabilities Act (ADA) accessible curb ramps on all four corners. Pedestrian facilities located within the Study Area and are further detailed in Figure 5. An inventory of pedestrian attractors within a 0.25-mile walking distance from the Project Site is illustrated in Figure 6.

Vision Zero. As described in *Vision Zero: Eliminating Traffic Deaths in Los Angeles by 2025* (City of Los Angeles, August 2015), Vision Zero is a traffic safety policy that promotes strategies to eliminate transportation-related collisions that result in severe injury or death. Vision Zero has identified a High Injury Network (HIN), a network of streets included based on collision data from the last five years, where strategic investments would have the biggest impact in reducing death and severe injury. Adjacent to the Project Site, Vine Street has been identified as part of the HIN. Additionally, the following streets within 0.25 miles of the Project are also identified in the HIN (and depicted in Figure 6):

- Santa Monica Boulevard
- Cahuenga Boulevard

Existing Bicycle System. The Mobility Plan includes the specific goals and policies of *2010 Bicycle Plan, A Component of the City of Los Angeles Transportation Element* (LADCP, 2010) (2010 Bicycle Plan). The Mobility Plan establishes the overall framework for those components of the 2010 Bicycle Plan and builds upon those goals of improving bicycling for all levels of experience. Currently, Class III bicycle sharrows are provided on Fountain Ave and Vine Street within the Study Area. Vine Street & Fountain Avenue (Intersection #1) also provides a Metro Bike Share station approximately 375 feet north of the Project Site.

² Walk Score (www.walkscore.com) rates the Project Site with a score of 96 of 100 possible points (scores assessed on August 30, 2022, for 1200 Vine Street). Walk Score calculates the walkability of specific addresses by taking into account the ease of living in the neighborhood with a reduced reliance on automobile travel.

Existing Transit System. Figure 7 illustrates the existing transit service in the Study Area, which is served by bus lines operated by Metro and LADOT DASH. Nearest to the Project Site, Metro Local Line 210 stops at Vine Street & Lexington Avenue (Intersection #2), LADOT DASH Hollywood Clockwise and Counterclockwise stop at Vine Street & Fountain Avenue (Intersection #1), Metro Local Line 4 stops at the nearby intersection of Vine Street & Santa Monica Boulevard, and LADOT DASH Hollywood/Wilshire stops at the nearby intersection of Gower Street & Lexington Avenue.

Table 1 summarizes the various transit line services operating in and around the Study Area for each of the providers in the region, the type of service (peak vs. off-peak, express vs. local), and frequency of service. The average frequency of transit service during the peak hours was derived from schedule information from each respective transit provider for the stop nearest the Project Site and were calculated consistent with the methodology identified in the Transportation System – Transit Technical Report of *Connect SoCal – The 2020-2045 Regional Transportation Plan / Sustainable Communities Strategy* {Southern California Association of Governments [SCAG], Adopted September 2020) (RTP/SCS). The schedule information includes transit route and frequencies based on Metro schedules effective October 23, 2022 and LADOT DASH Hollywood and Hollywood/Wilshire schedules effective August 3, 2020 and July 31, 2021, respectively.

Tables 2A and 2B summarize the total capacity of the Metro transit system and LADOT bus lines during the morning and afternoon peak hours based on the frequency of service of each line, detailed ridership data provided by the transit provider and the maximum seated and standing capacity of each bus or train. As shown, the Metro and LADOT bus lines within 0.25 miles of the Project Site currently provide additional capacity for 733 transit riders during the morning peak hour and 545 transit riders during the afternoon peak hour. A high quality transit corridor (HQTC) is defined in Section 21155 of the PRC as a corridor with fixed bus route service with service intervals of no more than 15 minutes during peak commute hours.

As shown in Table 1, Metro Local Line 4, which travels in the east-west direction along Santa Monica Boulevard, and Metro Local Line 210, which travels in the north-south direction along Vine Street, provide fixed bus route service with intervals of less than 15 minutes during both the morning and afternoon commuter peak periods (6:00 AM to 9:00 AM and 3:00 PM to 7:00 PM). Both Metro Local Line 4 and Metro Local Line 210 provide bus stops at the intersection of Vine Street & Santa Monica Boulevard, located approximately 680 feet south of the Project Site. As such, the intersection of Vine Street & Santa Monica Boulevard qualifies as a Major Transit Stop, and both Vine Street and Santa Monica Boulevard qualify as HQTCs. Accordingly, the Project Site's location within 0.50 miles of both a Major Transit Stop and a HQTC meets the transit proximity requirements required by PRC Section 21155(b).

Existing Traffic Volumes. Traffic count data collection is generally conducted during times with typical travel demand patterns (i.e., when local schools are in session, businesses are in full operation, weeks without holidays, etc.) Collection of new traffic count data was not conducted in light of the Safer at Home order in response to COVID-19. Consistent with the TAG, based on historical trends in traffic growth, an ambient growth rate of 1% per year was applied to weekday morning (7:00 AM to 10:00 AM) and afternoon (3:00 PM to 6:00 PM) peak period intersection counts from May 2018 to represent Year 2022 conditions. The existing intersection peak hour traffic volumes are illustrated in Figure 8.

Future Cumulative Transportation Conditions

The future conditions detail the assumptions used to develop the Future without Project Conditions in Year 2027, which corresponds to expected occupancy of the Project.

The Future without Project Conditions traffic volumes include ambient growth, which reflects the increase in traffic due to regional growth and development outside the Study Area, as well as traffic generated by ongoing or entitled projects near or within the Study Area (the Related Projects) in accordance with procedures outlined in the CEQA Guidelines.

Ambient Traffic Growth. Traffic levels are expected to increase over time as a result of regional growth and development in and around the Study Area. Based on discussions with LADOT through the MOU process, a conservative ambient growth factor of 1% per year compounded annually was applied by inflating the existing traffic volumes to simulate Year 2027 traffic volumes. The total adjustment applied over the five-year period was 5.10%. These growth factors account for increases in traffic due to potential projects not yet proposed and projects located outside the Study Area.

Related Projects. The list of Related Projects is based on information provided by LADCP and LADOT, as well as recent studies in the area. The Related Projects are detailed in Table 3 and their approximate locations are shown in Figure 9. Though the buildout years of many of these Related Projects are uncertain and may be well beyond the buildout year of the Project, and notwithstanding that some may never be approved or developed, they were all considered as part of this transportation assessment and conservatively assumed to be completed by the Project buildout year of 2027. The traffic growth due to the development of Related Projects considered in this analysis is conservative and, by itself, substantially overestimates the actual traffic volume growth in the area that would likely occur prior to Project buildout years. With the addition of the 1% per year ambient growth factor previously discussed, the Future without Project cumulative condition is even more conservative.

Peak hour traffic volumes resulting from Related Projects are shown in Figure 10 at each study intersection.

Future without Project Conditions Traffic Volumes. The Related Projects volumes were then added to the existing traffic volumes after adjustment for ambient growth through the projected Project completion year of 2027. These volumes represent the Future without Project Conditions (i.e., ambient traffic growth and Related Project traffic added to existing traffic volumes) for Year 2027 and are shown in Figure 11 for both study intersections.

Future Improvements. The analysis of Future Conditions considered roadway improvements that have been funded and are expected to be implemented prior to the buildout of the proposed Project, however, none were identified within the Study Area. Other proposed roadway improvement projects that are not funded and traffic/trip reduction strategies such as Transportation Demand Management (TDM) programs for individual buildings and developments were not considered in the Future Conditions analyses.

Although no planned improvements were identified within the Study Area, the Mobility Plan identifies key corridors as components of various “mobility-enhanced networks.” Each network is intended to focus on improving a particular aspect of urban mobility, including transit,

neighborhood connectivity, bicycles, pedestrians, and vehicles. The specific improvements that may be implemented in those networks have not yet been identified, and there is no schedule for implementation; therefore, no changes to vehicular lane configurations were made as a result of the Mobility Plan. However, the following mobility-enhanced networks included corridors within or near the Study Area and depicted in Figure 12:

- Transit Enhanced Network (TEN): The TEN aims to improve existing and future bus services through reliable and frequent transit service in order to increase transit ridership, reduce single-occupancy vehicle trips, and integrate transit infrastructure investments within the surrounding street system. The TEN has designated Santa Monica Boulevard within the Study Area as part of the network.
- Neighborhood Enhanced Network (NEN): The NEN reflects the synthesis of the bicycle and pedestrian networks and serves as a system of local streets that are slow moving and safe enough to connect neighborhoods through active transportation. The NEN has designated Fountain Avenue, Cole Avenue, Gower Street, and De Longpre Avenue east of El Centro Avenue within the Study Area as part of the network.
- Bicycle Enhanced Network (BEN)/Bicycle Lane Network (BLN): No streets within the Study Area are designated as part of the BEN. The BLN has designated Vine Street and Santa Monica Boulevard within the Study Area as part of the network.
- Pedestrian Enhanced District (PED): The Mobility Plan aims to promote walking to reduce the reliance on automobile travel by providing more attractive and pedestrian-friendly sidewalks, as well as adding pedestrian signalizations, street trees, and pedestrian-oriented design features. The PED has designated Vine Street, Fountain Avenue between Cahuenga Avenue and Gower Street, Santa Monica Boulevard west of Gower Street, Cahuenga Boulevard north of Fountain Avenue and south of La Mirada Avenue, Cole Avenue north of Fountain Avenue and south of La Mirada Avenue, and Gower Street north of Fountain Avenue within the Study Area as part of the network.

PROJECT TRAFFIC

Trip generation estimates, trip distribution patterns and trip assignments were prepared for the Project.

Trip Generation

The number of trips generated by the Project was estimated using morning and afternoon peak hour rates for mid-rise multifamily housing and high-turnover sit-down restaurant published in *Trip Generation Manual, 11th Edition* (Institute of Traffic Engineers [ITE], 2021), as well as morning and afternoon peak hour rates for affordable housing units located inside a TPA based on empirical data collected in the City in 2016 and published in Table 3.3-2 of the TAG.

In consultation with LADOT during the MOU process, allowable trip generation reductions were applied to account for internal capture, public transit usage/walking arrivals, and pass-by trips:

- **Internal Capture:** A 10% internal capture reduction was applied to the commercial trip generation estimates to account for person trips made between the different uses of the Project without requiring an additional vehicle trip.
- **Transit Usage:** A 10% transit usage reduction was applied to the trip generation estimates (except for the affordable housing units, for which transit usage is assumed to be inherent in the trip generation rates) in accordance with the TAG methodology for a development within 0.25 miles of local bus stops.
- **Pass-By:** Consistent with Attachment H of the TAG, 20% pass-by reductions were applied to the commercial trip generation estimates to account for Project trips made as an intermediate stop on the way from an origin to a primary trip destination without route diversion.

It should be noted that, to provide a more conservative analysis, no trip generation reductions were applied for the removal of existing uses at the Project Site.

As shown in Table 4, after accounting for the trip reductions above, the Project is anticipated to generate 97 morning peak hour trips (38 inbound trips, 59 outbound trips) and 95 afternoon peak hour trips (57 inbound trips, 38 outbound trips).

Project Trip Distribution

Traffic entering and exiting the Project was assigned to the surrounding street system by land use type and access provisions. The intersection-level trip distribution pattern for Project traffic at the study intersections is shown in Figures 13A and 13B for residential and commercial uses, respectively.

Project Trip Assignment

The Project trip generation estimates summarized in Table 4 and the trip distribution patterns shown in Figure 13A for residential uses and Figure 13B for commercial uses were used to assign the Project-generated traffic through the study intersections. Figure 14 illustrates the Project-only traffic volumes for the Project at the study intersections and driveways during typical weekday morning and afternoon peak hours.

CEQA ANALYSIS OF TRANSPORTATION IMPACTS

State of California Senate Bill 743 (Steinberg, 2013) (SB 743), made effective in January 2014, required the Governor's Office of Planning and Research to change the CEQA guidelines regarding the analysis of transportation impacts. Under SB 743, the focus of transportation analysis shifts from driver delay (level of service [LOS]) to vehicle miles traveled (VMT) in order to reduce greenhouse gas emissions (GHG), create multimodal networks, and promote mixed-use developments.

LADOT's TAG defines the methodology for analyzing a project's transportation impacts in accordance with SB 743.

The TAG and CEQA Guidelines Appendix G identifies four CEQA thresholds applicable to the Project for identifying significant transportation impacts in accordance with SB 743:

- Threshold T-1: Conflicting with Plans, Programs, Ordinances, or Policies
- Threshold T-2.1: Causing Substantial Vehicle Miles Traveled (VMT)
- Threshold T-2.2: Substantially Inducing Additional Automobile Travel
- Threshold T-3: Substantially Increasing Hazards Due to a Geometric Design Feature or Incompatible Use

THRESHOLD T-1: CONFLICTING WITH PLANS, PROGRAMS, ORDINANCES, OR POLICIES

Threshold T-1 states that a project would result in a significant impact if it conflicts with a program, plan, ordinance, or policy adopted to protect the environment and that addresses the circulation system, including transit, roadways, bicycle, and pedestrian facilities. Table 2.1-1 of the TAG provides the City plans, policies, programs, ordinances, and standards relevant in determining project consistency. Attachment D of the TAG – *Plans, Policies, and Programs Consistency Worksheet* – provides a structured approach to evaluate whether a project conflicts with the City plans, programs, ordinances, or policies and streamlines the review by highlighting the most relevant plans, policies, and programs when assessing potential impacts to the City’s transportation system. The *Plans, Policies, and Programs Consistency Worksheet* was completed for the Project and is provided in Attachment C.

As stated in Section 2.1.4 of the TAG, a project that generally conforms with, and does not obstruct the City’s development policies and standards will generally be considered to be consistent. As summarized below, the Project is consistent with the transportation-related elements of the City documents listed in Table 2.1-1 of the TAG. Therefore, the Project would not result in a significant impact under Threshold T-1. Detailed discussion of the plans, programs, ordinances, or policies related is provided below.

Mobility Plan

The Mobility Plan combines “complete street” principles with the following five goals that define the City’s mobility priorities:

1. Safety First
2. World Class Infrastructure
3. Access for all Angelenos
4. Collaboration, Communication, and Informed Choices
5. Clean Environments and Healthy Communities

The Project location and site access is consistent with the goals of the Mobility Plan as the Project would be designed to provide safe access for all users. The Project would support the policies of the Mobility Plan as it would promote a balanced transportation system by locating affordable housing in proximity to transit, jobs, and local retail uses. The Project would meet the goals of the

Mobility Plan and would not interfere with the applicable policies of the Mobility Plan. Thus, the Project would be consistent with the Mobility Plan. The following provides further details of specific policies and programs in the Mobility Plan that were deemed most relevant to the Project.

- Policy 1.3 Safe Routes to School – Prioritize the safety of school children on all streets regardless of highway classifications. The City's Safe Routes to School program has not identified any infrastructure projects within the vicinity of the Project Site. Therefore, the Project would not conflict with Mobility Plan Policy 1.3.
- Policy 2.3 Pedestrian Infrastructure – Recognize walking as a component of every trip and ensure high quality pedestrian access in all site planning and public right-of-way (ROW) modifications to provide a safe and comfortable walking environment. Pedestrian access to the Project would be provided via commercial entrances along Vine Street and a residential lobby along Lexington Avenue. The Project includes pedestrian-friendly landscaping and design to enhance the pedestrian experience. The Project would also improve the existing sidewalks along the Project frontage in accordance with City standards. In addition, the Project's driveways would be designed to provide safe pedestrian crossings. Therefore, the Project would not conflict with Mobility Plan Policy 2.3.
- Policy 2.5 Transit Network – Improve the performance and reliability of existing and future bus service. As detailed in Tables 2A and 2B, the transit system serving the Project Site has available capacity for approximately 733 additional riders during the morning peak hour and 545 additional riders during the afternoon peak hour. Even with the increased ridership from the Project, ample transit capacity would be available to serve the Project area. As such, the Project would not cause the capacity of the transit system to be substantially exceeded and the Project would not conflict with Mobility Plan Policy 2.5.
- Policy 2.6 Bicycle Networks – Provide safe, convenient, and comfortable local and regional bicycling facilities for people of all types and abilities. Class III bicycle sharrows are provided on Fountain Ave and Vine Street within the Study Area. Vine Street & Fountain Avenue (Intersection #1) also provides a Metro Bike Share station approximately 375 feet north of the Project Site. Vine Street is part of the BLN in the Mobility Plan. The Project's driveways would be designed to minimize conflicts with bicycles, and bicyclists would have the same access opportunities to the Project Site as pedestrians. In accordance with the requirements of Los Angeles Municipal Code (LAMC) Section 12.21-A, 16(a), the Project would provide 120 bicycle parking spaces, including 14 short-term and 106 long-term bicycle parking spaces. Therefore, the Project would not conflict with Mobility Plan Policy 2.6.
- Policy 2.9 Multiple Networks – Consider the role of each enhanced network (i.e., TEN, PED, and BEN) when designing a street that includes multiple modes. As discussed above, in the analyses for Policies 2.5 and 2.6, the Project would not conflict with Mobility Plan policies related to transit and bicycle networks. Vine Street adjacent to the Project Site is identified as part of the PED and BLN. The Project would upgrade the existing sidewalk on Vine Street along the Project frontage to meet Mobility Plan standards. Additionally, bicycle parking that meets LAMC requirements would be provided. Bicyclists and pedestrians would have separate entrances from vehicles and the Project's driveways would be designed in line with the Driveway Design Guidelines. Both Vine Street and

Lexington Avenue currently meet the Mobility Plan standards; therefore, the Project would not be required to provide dedications along the Project frontage, and completion of the Project would not preclude implementation of the Mobility Plan. Therefore, the Project would not conflict with Mobility Plan policies related to any of the enhanced networks in the Mobility Plan.

- Policy 2.10 Loading Area – Facilitate the provision of adequate on and off-street loading areas. The Project would provide on-site loading areas on the ground floor parking level. As such, delivery trucks would not encroach on or block the public ROW. Therefore, the Project would not conflict with Mobility Plan Policy 2.10.
- Policy 3.2 People with Disabilities – Accommodate the needs of people with disabilities when modifying or installing infrastructure in the public ROW. Both vehicular and pedestrian access to the Project from the public ROW would be designed to meet the standards of ADA requirements. Therefore, the Project would not conflict with Mobility Plan Policy 3.2.

Plan for a Healthy Los Angeles

Plan for a Healthy Los Angeles: A Health and Wellness Element of the General Plan (LADCP, March 2015) (Plan for a Healthy Los Angeles) introduces guidelines for the City to follow to enhance the City's position as a regional leader in health and equity, encourage healthy design and equitable access, and increase awareness of equity and environmental issues.

The Project supports healthy lifestyles by reducing single-occupant vehicle trips by virtue of its location near to abundant high-quality and high-frequency transit options and its provision of bicycle parking per the LAMC. The Project does not interfere with any other policies recommended by the plan. Therefore, the Project is consistent with Plan for a Healthy Los Angeles.

LAMC Section 12.21-A.16

LAMC Section 12.21.A.16 details the bicycle parking requirements for new developments. In accordance with the requirements of the LAMC, the Project would provide a total 120 bicycle parking spaces, including 14 short-term and 106 long-term bicycle parking spaces.

LAMC Section 12.26-J

LAMC Section 12.26J, the adopted TDM Ordinance (1993), establishes TDM requirements for projects with at least 25,000 sf of non-residential gross floor area³. The Project does not include non-residential floor area in excess of 25,000 sf and, therefore, the TDM Ordinance does not apply.

³ The TDM Ordinance is currently being updated and is progressing through the City's approval process. The updated TDM Ordinance will expand the reach and application of TDM strategies to more land uses, including residential uses.

LAMC Section 12.37

LAMC Section 12.37 pertains to development or expansion of buildings along Highways and Collector Streets and applies to streets designated Boulevard I, Boulevard II, Avenue I, Avenue II, and Avenue III in the Mobility Plan. Vine Street is a designated Avenue II in the Mobility Plan, and currently meets the ROW standards of the Mobility Plan. Therefore, the Project would not be required to provide a dedication along the Project frontage. Thus, the Project would be consistent with the requirements of LAMC Section 12.37.

Vision Zero

The primary goal of Vision Zero is to eliminate traffic deaths in the City by 2025. Vision Zero identifies the HIN, a network of streets where strategic investments will have the biggest impact in reducing death and severe injury. Annually developed Action Plans emphasize creating safe streets for all users, developing a culture of safety, adopting policy measures to promote safety, and using data to inform the most effective solutions. The information from this review comes from the City's *Vision Zero Los Angeles: 2018 Action Plan + Progress Report* (2018) and LADOT's list of active Vision Zero projects maintained at www.ladotlivablestreets.org.

Adjacent to the Project Site, Vine Street has been identified as part of the HIN but has not been identified as a Priority Corridor. Therefore, no Vision Zero improvements are currently planned adjacent to the Project Site. Nevertheless, the Project would not preclude future Vision Zero safety improvements by the City. Thus, the Project does not conflict with Vision Zero.

Citywide Design Guidelines for Residential, Commercial, and Industrial Development

Citywide Design Guidelines (LADCP Urban Design Studio, October 2019) identifies urban design principles to guide architects and developers in designing high-quality projects that meet the City's functional, aesthetic, and policy objectives and help foster a sense of community. *Citywide Design Guidelines* is organized around six design objectives. *City of Los Angeles Urban Design Principles* (LADCP, 2011) aims to improve mobility in the City through travel mode choices.

The Project would provide affordable housing in proximity to a broad range of land uses and transit options within walking distance, which would encourage pedestrian activity. The Project would be integrated within the surrounding area by providing improved sidewalks and landscaping. Pedestrian connections would be provided via separate entrances from vehicle entrances. In addition, loading activities would occur on-site. Therefore, the Project would align with *Citywide Design Guidelines* to provide a safe, comfortable, and accessible experience for all transportation modes.

Cumulative Analysis

In addition to potential Project-specific impacts, the TAG requires that the Project be reviewed in combination with nearby Related Projects to determine if there may be a cumulatively significant impact resulting from inconsistency with a particular program, plan, policy, or ordinance. In accordance with the TAG, the cumulative analysis must include consideration of any Related

Projects within 0.50 miles of the Project Site and any transportation system improvements in the vicinity.

Each of the Related Projects considered in this cumulative analysis of consistency with programs, plans, policies, and ordinances would be separately reviewed and approved by the City, including a check for their consistency with applicable policies. Collectively, the Project and the Related Projects add higher-density development in a high-quality transit area, which would increase pedestrian activity and reduce the need for single occupancy vehicles. Therefore, the Project, together with the Related Projects identified in this study, would neither create inconsistencies nor result in cumulative impacts with respect to the identified programs, plans, policies, and ordinances.

THRESHOLD T-2.1 – CAUSING SUBSTANTIAL VMT

The VMT metric is intended to promote the reduction of greenhouse gas emissions, the development of multimodal transportation networks, and a diversity of land uses. This encourages development that shortens the distance between housing, jobs, and services, increases the availability of affordable housing options in proximity to public transit, offers attractive non-vehicular transportation alternatives, provides strong transportation demand management programs, and promotes walking and bicycling trips.

VMT Impact Thresholds

The TAG identifies significance thresholds to apply to development projects when evaluating potential VMT impacts consistent with the California Governor's Office of Planning and Research (OPR) CEQA guidance. Threshold T-2.1 (Causing Substantial Vehicle Miles Traveled) of the TAG states that a residential project would result in a significant VMT impact if it cannot demonstrate average household VMT per capita of at least 15% below the existing standard for the Area Planning Commission (APC) in which it is located.

The Project is located in the Central APC which, according to the TAG, has an average household VMT per capita impact threshold of 6.0. Therefore, should the Project's average household VMT per capita be equal to or lower than 6.0, the Project's overall VMT impact would be less than significant.

VMT Analysis Methodology

LADOT developed the *City of Los Angeles VMT Calculator Version 1.3* (July 2020) (VMT Calculator) to estimate project-specific daily household VMT per capita and daily work VMT per employee for developments within City limits, which are based on the following types of one-way trips:

- Home-Based Work Production: origin trips from a residential use to a workplace destination

- Home-Based Other Production: origin trips from a residential use to a non-workplace destination (e.g., retail, restaurant, etc.)
- Home-Based Work Attraction: destination trips to a workplace originating from a residential use

As detailed in *City of Los Angeles VMT Calculator Documentation* (LADOT and LADCP, May 2020), the household VMT per capita threshold applies to home-based work production and home-based other production trips, and the work VMT per employee threshold applies to home-based work attraction trips, as the location and characteristics of residences and workplaces are often the main drivers of VMT, as detailed in Appendix 1 of *Technical Advisory on Evaluating Transportation Impacts in CEQA* (OPR, December 2018).

Other types of trips in the VMT Calculator, including Non-Home-Based Other Production (trips to a non-residential destination originating from a non-residential use), Home-Based Other Attraction (trips to a non-workplace destination originating from a residential use), and Non-Home-Based Other Attraction (trips to a non-residential destination originating from a non-residential use), are not factored into the VMT per capita and VMT per employee thresholds as those trips are typically localized and are assumed to have a negligible effect on the VMT impact assessment. However, those trips are factored into the calculation of total project VMT for LADOT screening purposes when determining if further VMT analysis for a project would be required.

The methodology in determining VMT based on the VMT Calculator is consistent with the TAG.

Travel Behavior Zone (TBZ). The City developed TBZ categories to determine the magnitude of VMT and vehicle trip reductions that could be achieved through TDM strategies. As detailed in *City of Los Angeles VMT Calculator Documentation*, the development of the TBZs considered the population density, land use density, intersection density, and proximity to transit of each Census tract in the City and are categorized as follows:

1. *Suburban (Zone 1): Very low-density primarily centered around single-family homes and minimally connected street network.*
2. *Suburban Center (Zone 2): Low-density developments with a mix of residential and commercial uses with larger blocks and lower intersection density.*
3. *Compact Infill (Zone 3): Higher density neighborhoods that include multi-story buildings and well-connected streets.*
4. *Urban (Zone 4): High-density neighborhoods characterized by multi-story buildings with a dense road network.*

The VMT Calculator determines a project's TBZ based on the latitude and longitude of the project address. The Project is located in an Urban (Zone 4) TBZ.

Trip Lengths. The VMT Calculator determines a project's VMT based on trip length information from the City's Travel Demand Forecasting (TDF) Model. The TDF Model considers the traffic analysis zones within 0.125 miles of a project to determine the trip lengths and trip types, which factor into the calculation of a project's VMT.

Population and Employment Assumptions. As previously stated, the VMT thresholds identified in the TAG are based on household VMT per capita and work VMT per employee. Thus, the VMT Calculator contains population assumptions developed based on Census data for the City and employment assumptions derived from multiple data sources, including *2012 Developer Fee Justification Study* (Los Angeles Unified School District, 2012), the San Diego Association of Governments Activity Based Model, *Trip Generation Manual, 9th Edition* (ITE, 2012), the US Department of Energy, and other modeling resources. A summary of population and employment assumptions for various land uses is provided in Table 1 of *City of Los Angeles VMT Calculator Documentation*.

TDM Measures. Additionally, the VMT Calculator measures the reduction in VMT resulting from a project's incorporation of TDM strategies as project design features or mitigation measures. The following seven categories of TDM strategies are included in the VMT Calculator:

1. Parking
2. Transit
3. Education and Encouragement
4. Commute Trip Reductions
5. Shared Mobility
6. Bicycle Infrastructure
7. Neighborhood Enhancement

TDM strategies within each of these categories have been empirically demonstrated to reduce trip-making or mode choice in such a way as to reduce VMT, as documented in *Quantifying Greenhouse Gas Mitigation Measures* (California Air Pollution Control Officers Association, 2010). As detailed in *Transportation Demand Management Strategies in LA VMT Calculator* (LADOT, November 2019), the effectiveness of the TDM strategies applied in the VMT Calculator is based on the research presented in *Quantifying Greenhouse Gas Mitigation Measures*, as well as localized data. To ensure that the cumulative effectiveness of the applied TDM strategies is not overstated, a multiplicative dampening formula is applied to account for potential overlaps in users of each strategy.

Project VMT Analysis

The VMT Calculator was used to evaluate Project VMT and compare it to the VMT impact criteria. Table 5 summarizes the Project VMT evaluation. The detailed worksheets from the VMT Calculator are provided in Attachment D.

Project VMT. It should be noted that as part of the Project design, measures would be implemented to reduce the number of single occupancy vehicle trips to the Project Site. For the purposes of this analysis, the VMT evaluation accounted for a reduced parking supply from baseline LAMC requirements and the inclusion of short-term and long-term bicycle parking per LAMC requirements.

As shown in Table 5, the VMT Calculator estimates that the Project would generate 1,320 total household VMT. Thus, based on the population assumptions, the Project would generate an average household VMT per capita of 3.7, which would not exceed the significance thresholds for

the Central APC (6.0 household VMT per capita). Therefore, the Project would not result in a significant household VMT impact, and no mitigation measures would be required.

Cumulative Analysis. The TAG provides that cumulative effects of development projects are determined based on the consistency with the air quality and GHG reduction goals of the SCAG RTP/SCS in terms of development location, density, and intensity. The RTP/SCS presents a long-term vision for the region's transportation system through Year 2045 and balances the region's future mobility and housing needs with economic, environmental, and public health goals.

As detailed in the TAG, for projects that do not demonstrate a project impact by applying an efficiency-based impact threshold (i.e., household VMT per capita, work VMT per employee) in the project impact analysis, a less than significant impact conclusion is sufficient in demonstrating there is no cumulative VMT impact, as those projects are already shown to align with the long-term VMT and GHG goals of the RTP/SCS. The Project would not result in a significant household or work VMT impact, as detailed above. Therefore, the Project is not anticipated to result in a cumulative VMT impact under Threshold T-2.1, and no further evaluation or mitigation measures would be required.

Moreover, as previously detailed, the Project is located within a TPA as defined by the City and a High-Quality Transit Area as defined by the RTP/SCS. The Project's specific location in close proximity to high-quality transit and other off-site retail, restaurant, commercial, and residential areas, along with its highly walkable environment, support the conclusion that the Project would achieve a VMT reduction greater than the average for the area, as concluded in the Project VMT analysis provided above.

Thus, the Project encourages a variety of transportation options and is consistent with the RTP/SCS goal of maximizing mobility and accessibility in the region. The Project would also contribute to the productivity and use of the regional transportation system by providing housing near transit and encourage active transportation by providing new bicycle parking infrastructure and active street frontages, consistent with RTP/SCS goals. Therefore, the Project would not result in a cumulative VMT impact under Threshold T-2.1, and no further evaluation or mitigation measures would be required.

THRESHOLD T-2.2: SUBSTANTIALLY INDUCING ADDITIONAL AUTOMOBILE TRAVEL ANALYSIS

Threshold T-2.2 applies to transportation projects that increase vehicular capacity that leads to additional travel on the roadway network, which can include induced vehicle travel due to factors such as increased speeds and induced growth.

The Project does not include additional through traffic lanes on existing or new highways, general purpose lanes, high-occupancy vehicle lanes, peak period lanes, auxiliary lanes, or lanes through grade-separated interchanges. Accordingly, neither the Project nor any improvements associated with it are considered a transportation project. Therefore, Threshold T-2.2 does not apply to the Project and no further evaluation is required.

THRESHOLD T-3: SUBSTANTIALLY INCREASING HAZARDS DUE TO A GEOMETRIC DESIGN FEATURE OR INCOMPATIBLE USE

Impacts regarding the potential increase of hazards due to a geometric design feature generally relate to the design of access points to and from a project site, and may include safety, operational, or capacity impacts. Impacts can be related to vehicle/vehicle, vehicle/bicycle, or vehicle/pedestrian conflicts as well as to operational delays caused by vehicles slowing and/or queuing to access a project site. These conflicts may be created by the driveway configuration or through the placement of project driveway(s) in areas of inadequate visibility, adjacent to bicycle or pedestrian facilities, or too close to busy or congested intersections.

A review of Project access points, internal circulation, and parking access was conducted to determine if the Project would substantially increase hazards due to geometric design features, including safety, operational, or capacity impacts.

Vehicles

As previously detailed, vehicular access to the Project Site would be provided via one commercial driveway on Vine Street, a designated Avenue II, with right-turn-only ingress/egress and one full access residential driveway on Lexington Avenue, a designated Local Street. Both driveways would be designed in accordance with City standards. Adequate queuing areas would also be provided at the driveways internal to the Project Site to limit any potential spillover into the public streets.

Therefore, as detailed above, the vehicular access and internal circulation plan for the Project would be designed to minimize vehicular conflicts, and safety impacts to the abutting street system are not anticipated.

Pedestrians & Bicycles

Pedestrian and bicycle access to the Project would be provided via commercial entrances along Vine Street and a residential lobby along Lexington Avenue. Vine Street has been identified as part of Vision Zero's HIN and the Mobility Plan's PED and BLN. Vine Street also has Class III bicycle sharrows. The driveways would be designed to provide safe pedestrian and bicycle crossings and, therefore, would not pose any safety hazards.

Cumulative Analysis

The TAG indicates that cumulative impacts for Threshold T-3 require a review of related projects with access points proposed along the same block(s) as a proposed project in order to determine the combined impact and the proposed project's contribution. None of the Related Projects identified in Table 3 provides access along the same block as the Project. Thus, the Project and Related Projects would not result in a cumulative impact under Threshold T-3.

Freeway Safety Analysis

The TAG guidance on identifying requirements for a CEQA safety analysis of California department of Transportation (Caltrans) facilities as part of a transportation assessment.

Methodology. *Interim Guidance for Freeway Safety Analysis* (LADOT, May 2020) (City Freeway Guidance) relates to the identification of potential safety impacts at freeway off-ramps as a result of increased traffic from development projects. It provides a methodology and significance criteria for assessing whether additional vehicle queueing at off-ramps could result in a safety impact due to speed differentials between the mainline freeway lanes and the queued vehicles at the off-ramp.

Based on the City Freeway Guidance, a transportation assessment for a development project must include analysis of any freeway off-ramp where the project adds 25 or more peak hour trips. A project would result in a significant impact at such a ramp if each of the following three criteria were met:

1. Under a scenario analyzing future conditions upon project buildout, with project traffic included, the off-ramp queue would extend to the mainline freeway lanes⁴.
2. A project would contribute at least two vehicle lengths (50 feet, assuming 25 feet per vehicle) to the queue.
3. The average speed of mainline freeway traffic adjacent to the off-ramp during the analyzed peak hour(s) is greater than 30 mph.

Should a significant impact be identified, mitigation measures to be considered include TDM strategies to reduce a project's trip generation, investments in active transportation or transit system infrastructure to reduce a project's trip generation, changes to the traffic signal timing or lane assignments at the ramp intersection, or physical changes to the off-ramp. Any physical change to the ramp would have to improve safety, not induce greater VMT, and not result in secondary environmental impacts.

Analysis. Based on the Project's trip generation estimates and trip assignments, the Project would not add 25 or more peak hour trips to any freeway off-ramp. Therefore, no further freeway off-ramp queuing analysis is required. Furthermore, the Project would not result in a significant safety impact, and no corrective measures at any freeway off-ramps would be required.

NON-CEQA TRANSPORTATION ANALYSIS

The non-CEQA transportation analysis of the Project includes sections related to the Project traffic, proposed access provisions, safety, and circulation operations of the Project, and pedestrian, bicycle, and transit facilities in the vicinity of the Project, as well as the Project's operational conditions and effects due to Project construction.

⁴ If an auxiliary lane is provided on the freeway, then half the length of the auxiliary lane is added to the ramp storage length.

Per Section 3.1 of the TAG, any deficiencies identified based on the non-CEQA transportation analysis is “not intended to be interpreted as thresholds of significance, or significance criteria for purposes of CEQA review unless otherwise specifically identified in Section 2.” Section 3 of the TAG identifies the following four non-CEQA transportation analyses for reviewing potential transportation deficiencies that may result from a development project:

- Pedestrian, Bicycle, and Transit Access Assessment
- Project Access, Safety, and Circulation Evaluation
- Residential Street Cut-Through Analysis
- Project Construction

PEDESTRIAN, BICYCLE, AND TRANSIT ASSESSMENT

The TAG indicates that the pedestrian, bicycle, and transit facilities assessment is intended to determine a project’s potential effect on pedestrian, bicycle, and transit facilities in the vicinity of the proposed project. The deficiencies could be physical (through removal, modification, or degradation of facilities) or demand-based (by adding pedestrian or bicycle demand to inadequate facilities).

Project Modifications

As previously described, vehicular access to the Project would be provided via one right-turn-only ingress/egress driveway along Vine Street and one full access driveway along Lexington Avenue. Both Project driveways would improve existing curb cuts to meet City standards. In addition, the Project would remove an existing curb cut along Vine Street to reduce vehicular interruptions to pedestrian flow and safety.

The Project would improve the adjacent sidewalk facilities to meet ADA requirements for slopes and passable spaces, including ADA compliance at driveways. The Project would not remove or cause degradation of existing sidewalks, crosswalks, pedestrian refuge areas or curb extensions, nor would the Project narrow existing sidewalks, paths, crossings, or access points.

The Project would not result in the deterioration of any existing bicycle facilities or transit facilities as no dedicated bicycle facilities or transit stops are located adjacent to the Project Site.

Intensification of Use

The Project would not directly or indirectly result in a permanent removal or modification of infrastructure or degrade pedestrian or bicycle facilities. Although the Project may slightly intensify use of existing pedestrian and bicycle facilities adjacent to the Project Site, the Project would maintain the existing ROW along the Vine Street and Lexington Avenue frontages. Thus, the Project would not result in the deterioration of any existing facilities serving pedestrians or bicyclists.

Further, the Project would result in some intensification of transit activity in the vicinity of the Project Site. However, given the Project Site’s location near local bus services and its proximity

to active commercial centers, it is ideally located to encourage non-automobile trips to and from those destinations and to reach additional public transit routes. Based on the trip estimates in Table 4 with application of an average vehicle occupancy factor of 1.55 for trips in Los Angeles County as identified in *SCAG Regional Travel Demand Model and 2012 Model Validation* (Southern California Association of Governments, March 2016), the Project is estimated to add approximately 19 new transit riders during the morning peak hour and 17 riders during the afternoon peak hour. The Project's transit trip estimate would account for approximately 2% of the residual peak hour transit capacity estimated in Tables 2A and 2B and, therefore, the Project would not constrain transit capacity.

As such, the amount of additional pedestrian, bicycle, and transit activity generated by the Project would not strain the capacity of facilities and operations dedicated to those modes.

PROJECT ACCESS AND CIRCULATION EVALUATION

Project access and circulation constraints relate to the provision of access to and from the Project Site, and may include safety, operational, or capacity constraints. Constraints can be related to vehicular/vehicular, vehicular/bicycle, or vehicular/pedestrian constraints as well as to operational delays. These conflicts may be created by the driveway configuration or through the placement of project driveway(s) in areas of inadequate visibility, adjacent to bicycle or pedestrian facilities, or too close to an intersection or crosswalk.

Vehicular Access & Internal Circulation

Vehicular access to the Project Site would be provided via driveways along Vine Street and Lexington Avenue. Access via Vine Street would be limited to right-turn-only ingress/egress maneuvers due to the proximity to adjacent intersections. The driveway along Lexington Avenue would provide both left- and right-turn ingress/egress access. Adequate queuing area would also be provided at the driveway internal to the Project Site to limit any potential spillover into the public ROW.

Pedestrians and Bicycles

Pedestrian and bicycle access to the Project would be provided via commercial entrances along Vine Street and a residential lobby along Lexington Avenue. The Project would also include an outdoor plaza with access along Lexington Avenue. The Project's pedestrian access locations would be designed to provide direct connections to public pedestrian sidewalks. The driveway and internal circulation system would be designed to maximize sight distance for all travel modes. The design is sensitive to not place street trees and other potential impediments in the sidewalk that would affect sight distance and visibility.

Residents, guests, and employees arriving by bicycle would have the same access opportunities as pedestrian visitors. The Project would not introduce new curb cuts and the Project driveways would be designed to limit potential vehicle/bicycle conflicts. In order to support and facilitate bicycle use to and from the Project Site, short-term and long-term bicycle parking spaces would be provided.

Operational Evaluation

Intersection operation conditions were evaluated at the two study intersections for typical weekday morning (6:00 AM to 10:00 AM) and afternoon (3:00 PM to 7:00 PM) peak periods. The following traffic conditions were developed and analyzed as part of this study:

- **Existing with Project Conditions (Year 2022)** – This analysis condition analyzes the potential intersection operating conditions that could be expected if the Project were built under existing conditions. In this analysis, the Project-generated traffic is added to the Existing Conditions.
- **Future with Project Conditions (Year 2027)** – This analysis condition analyzes the potential intersection operating conditions that could be expected if the Project were fully occupied in the projected buildout year. In this analysis, the Project-generated traffic is added to Future without Project Conditions (Year 2027).

Methodology. In accordance with the TAG, the intersection delay and queue analyses for the operational evaluation were conducted using the *Highway Capacity Manual, 6th Edition* (Transportation Research Board, 2016) (HCM) methodology. The HCM methodology was implemented using Synchro software and signal timing worksheets from the City to analyze intersection operating conditions. The HCM signalized methodology calculates the average delay, in seconds, for each vehicle passing through the intersections. Table 6 presents a description of the LOS categories, which range from excellent, nearly free-flow traffic at LOS A, to stop-and-go conditions at LOS F, for signalized and unsignalized intersections. The queue lengths were estimated using Synchro, which reports the 95th percentile queue length in feet. The reported queues are calculated using the HCM signalized intersection methodology.

LOS and queuing worksheets for each scenario are provided in Attachment E.

Existing with Project Conditions. The Project-only morning and afternoon peak hour traffic volumes were added to the Existing morning and afternoon peak hour traffic volumes, resulting in the Existing with Project Conditions traffic volumes illustrated in Figure 15, representing Project operation under Existing Conditions.

Table 7 summarizes the results of the Existing Conditions and Existing with Project Conditions during the weekday morning and afternoon peak hours for the two study intersections. As shown, both study intersections are anticipated to continue to operate at LOS C or better during both the morning and afternoon peak hours under Existing with Project Conditions.

Future with Project Conditions. All future adjustments, including cumulative traffic growth (i.e., ambient growth and Related Project traffic) and transportation infrastructure improvements were incorporated into this analysis.

The Project-only morning and afternoon peak hour traffic volumes were added to the Future without Project Conditions (Year 2027) morning and afternoon peak hour traffic volumes, resulting in the Future with Project Conditions traffic volumes illustrated in Figure 16, representing conditions after development of the Project in Year 2027.

Table 8 summarizes the results of the Future without Project Conditions (Year 2027) and Future with Project Conditions during the weekday morning and afternoon peak hours for the two study intersections. As shown, both study intersections are anticipated to continue to operate at LOS D or better during both the morning and afternoon peak hours under Future with Project Conditions.

Intersection Queuing Analysis. In accordance with operational evaluation guidelines detailed in Section 3.3.3 of the TAG, the Project traffic was evaluated to determine whether the Project access would contribute to unacceptable queuing on an Avenue or Boulevard (as designated in the Mobility Plan) at Project driveways or would cause or substantially extend queuing at nearby signalized intersections. Per the TAG, unacceptable or extended queuing may be defined as follows:

- *Additional queue along through lanes and either of the following conditions are expected:*
 - *The projected peak hour intersection LOS is D and the through lane queue increases by greater than 75 feet on any approach with the directional approach LOS at E or F, or*
 - *The projected peak hour intersection LOS is E or F and the through lane queue increases by greater than 50 feet on any approach with the directional approach LOS at E or F.*
- *Spill over from turn pockets into through lanes.*
- *Block cross streets or alleys.*
- *Spill over from drive-throughs into streets.*
- *Contribute to “gridlock” congestion. For the purposes of this section, “gridlock” is defined as the condition where traffic queues between closely-spaced intersections and impedes the flow of traffic through upstream intersections.*

The queue lengths were estimated using Synchro software, which reports the 95th percentile queue length, in vehicles, for each approach lane. The queue lengths were then converted into linear distance by multiplying vehicle lengths by 25 feet. The reported queues are calculated using the HCM signalized intersection methodology.

The queuing analysis under Future Conditions (Year 2027) is provided in Table 9. As detailed, the addition of Project trips would not cause extended queuing or unacceptable conditions at either study intersection. Detailed queuing analysis worksheets are provided in Appendix E.

RESIDENTIAL STREET CUT-THROUGH ANALYSIS

The objective of the residential street cut-through analysis is to determine potential increases in average daily traffic volumes on designated Local Streets, as classified in the City’s General Plan, that can be identified as cut-through trips generated by the Project and that can adversely affect the character and function of those streets.

Section 3.5.2 of the TAG provides a list of questions to assess whether the Project would negatively affect residential streets. The net daily trips generated by the Project are not anticipated to cause a traffic shift from Vine Street, a designated Avenue II, to alternative routes along residential Local Streets. In addition, access to the Project is provided along Vine Street, in proximity to regional connections. Furthermore, Project trips utilizing Lexington Avenue to access the Project Site would not be considered cut-through traffic. Thus, based on the location of the Project Site, it is unlikely

that local residential streets would serve as an alternative route. Therefore, the addition of Project trips would not adversely affect any residential Local Streets.

CONSTRUCTION IMPACT ANALYSIS

The construction impact analysis relates to the temporary impacts that may result from the construction activities associated with the Project and was performed in accordance with Section 3.4 of the TAG, which identifies three types of in-street construction impacts that require further analysis to assess the effects of Project construction on the existing pedestrian, bicycle, transit, or vehicle circulation. The three types of impacts and related populations are:

1. Temporary transportation constraints – potential impacts on the transportation system
2. Temporary loss of access – potential impacts on visitors entering and leaving sites
3. Temporary loss of bus stops or rerouting of bus lines – potential impacts on bus travelers

The factors used to determine the significance of a project's impacts involve the likelihood and extent to which an impact might occur, the potential inconvenience caused to users of the transportation system, and consideration for public safety. Construction activities could potentially interfere with pedestrian, bicycle, transit, or vehicle circulation and accessibility to adjoining areas.

Proposed Construction Schedule

The Project is anticipated to be constructed over a period of approximately 35 months. The construction period would include sub-phases of demolition, grading and excavation, trenching, building construction, and architectural coatings. Peak haul truck activity occurs during the grading and excavation phase, and peak worker activity occurs during construction building phase. These two sub-phases of construction were studied in greater detail.

Grading and Excavation Phase

The peak period of truck activity during construction of the Project would occur during the grading and excavation phase of the Project Site.

Haul trucks would travel on approved truck routes designated within the City from Vine Street to US 101. The haul route will be reviewed and approved by the City. Based on projections compiled for the Project, approximately 10,000 cubic yards of material would be excavated and removed from the Project Site and would require on average 23 haul trucks per day. Thus, on average, 46 daily haul truck trips (23 inbound, 23 outbound) are forecast to occur during the grading and excavation phase, with approximately eight trips per hour (four inbound, four outbound) uniformly over a typical six-hour haul period (i.e., outside of commuter peak hours).

Transportation Research Circular No. 212, Interim Materials on Highway Capacity (Transportation Research Board, 1980) defines passenger car equivalency (PCE) for a heavy vehicle as the number of through moving passenger cars to which it is equivalent based on the heavy vehicle's headway and delay-creating effects. Table 8 of *Transportation Research Circular No. 212* and Exhibit 12-25 of the HCM suggest a PCE of 2.0 for trucks. Assuming a PCE factor of 2.0, the 46

truck trips would be equivalent to 92 daily PCE trips. The eight hourly truck trips would be equivalent to 16 PCE trips (eight inbound, eight outbound) per hour.

With implementation of the Construction Management Plan, it is anticipated that almost all haul truck activity to and from the Project Site would occur outside of the morning and afternoon commuter peak hours. In addition, construction worker trips to and from the Project Site would also occur outside of the peak hours. Therefore, no peak hour construction traffic impacts are expected during the site clearing and utility relocation phase of construction.

Building Construction Phase

According to construction projections prepared for the Project, the building construction subphase would employ the most construction workers, with an anticipated total of 100 workers per day for all components of the building after the structure is completed.

In general, the hours of construction typically require workers to be on-site before the weekday morning commuter peak period and allow them to leave before or after the afternoon commuter peak period (i.e., arrive at the site prior to 7:00 AM and depart before 4:00 PM or after 6:00 PM). Therefore, most, if not all, construction worker trips would occur outside of the typical weekday commuter peak periods.

Assuming minimal carpooling amongst those workers, an average vehicle occupancy of 1.135 persons per vehicle was applied, as provided in *CEQA Air Quality Handbook* (South Coast Air Quality Management District, 1993), 100 workers would result in a total of 88 vehicles that would arrive and depart from the Project Site each day. The estimated number of daily trips associated with the construction workers is approximately 176 (88 inbound and 88 outbound trips), but nearly all of those trips would occur outside of the peak hours, as described above. As such, the building phase of Project construction would not cause a significant traffic impact at any of the study intersections.

Parking for construction workers would be secured off-site in a nearby parking facility. Restrictions against workers parking in the public ROW in the vicinity of (or adjacent to) the Project Site would be identified as part of the Construction Management Plan. All construction materials storage and truck staging would be contained on-site or provided on-demand/as needed to reduce the need for storage.

Potential Impacts on Access, Transit, And Parking

Project construction is not expected to create hazards for roadway travelers, bus riders, or parkers, so long as commonly practiced safety procedures for construction are followed. Such procedures and other measures (e.g., to address temporary traffic control, lane closures, sidewalk closures, etc.) would be incorporated into the Construction Management Plan. The construction-related impacts associated with access to other businesses and transit are anticipated to be less than significant, and the implementation of the Construction Management Plan described below would further reduce those impacts.

Access. Construction activities would be primarily contained within the Project Site boundaries. All construction equipment will be staged entirely on-site or delivered on an as needed basis. However, temporary closures of the public ROW (e.g., travel lanes, sidewalks) adjacent to the Project Site may be required during construction. Temporary traffic controls (e.g., use of directional signage, maintaining continuous and unobstructed pedestrian paths, and/or providing overhead covering) would be provided to direct traffic and/or pedestrians safely around any closures, as required in the Construction Management Plan.

Transit. The construction activities of the Project would require the temporary relocation of the Metro Local 210 stop located along Vine Street adjacent to the Project Site. The stop relocation would be coordinated with Metro. Metro would be notified should the Project construction affect any other Metro facilities.

Parking. Parking is not permitted along Vine Street adjacent to the Project Site. It is, however, permitted along Lexington Avenue adjacent to the Project Site where construction activities may result in a temporary removal of up to five unmetered parking spaces. As such, coordination with LADOT would be included in the Construction Management Plan.

Construction Management Plan

In accordance with Section 3.4.5 of the TAG, a detailed Construction Management Plan, including street closure information, a detour plan, haul routes, and a staging plan, would be prepared and submitted to the City for review and approval, prior to commencing construction. The Construction Management Plan would formalize how construction would be carried out and identify specific actions that would be required to reduce effects on the surrounding community. The Construction Management Plan shall be based on the nature and timing of the specific construction activities and other projects in the vicinity of the Project Site.

PARKING

The Project would provide a total of 93 vehicle parking spaces within one ground level and one above-grade level and a total of 120 bicycle parking spaces on-site (106 long-term and 14 short-term).

Vehicle Parking Code Requirements

LAMC Section 12.21.A4 identifies the base code parking rates for developments in the City. However, the Project is requesting to provide vehicle parking spaces at a reduced rate in accordance with State of California Assembly Bill 2345 (Government Code Section 65915) standards, which require no more than 0.5 parking spaces per dwelling unit for residential projects that include affordable units and apply for a density bonus. Additionally, the Project is in a State Enterprise Zone, which requires a reduced parking rate of two parking spaces per 1,000 square feet of commercial space, including restaurant uses. Therefore, as shown in Table 10, based on the rates above, the Project would be required to provide a total of 91 vehicle parking spaces.

Bicycle Parking Code Requirements

LAMC Section 12.21.A.16 details the long-term and short-term bicycle parking requirements for new developments, which are summarized in Table 11. As shown, the Project would require a total of 105 long-term and 14 short-term bicycle parking spaces.

CONCLUSION

The Project is consistent with the City's plans, programs, ordinances, and policies and would not generate any VMT, geometric design hazard, or emergency access impacts. Therefore, the Project would not result in a significant and unavoidable CEQA impact. In addition, the Project would not result in a significant safety impact on any Caltrans freeway off-ramp facilities. Furthermore, the Project is not anticipated to result in any operational deficiencies on the adjacent transportation system.

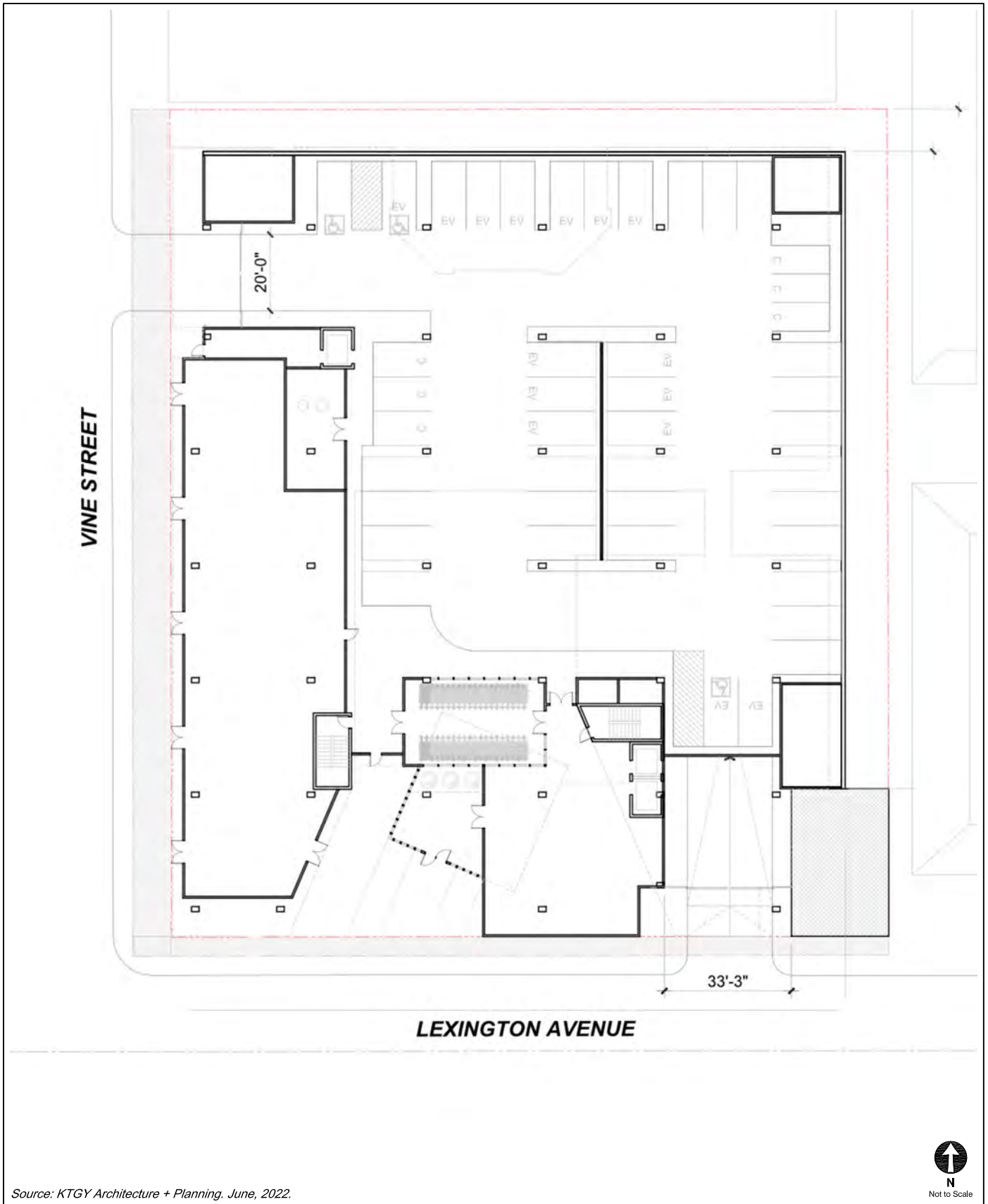

Source: KTG Architecture + Planning, June, 2022.

PROJECT SITE PLAN

FIGURE
1

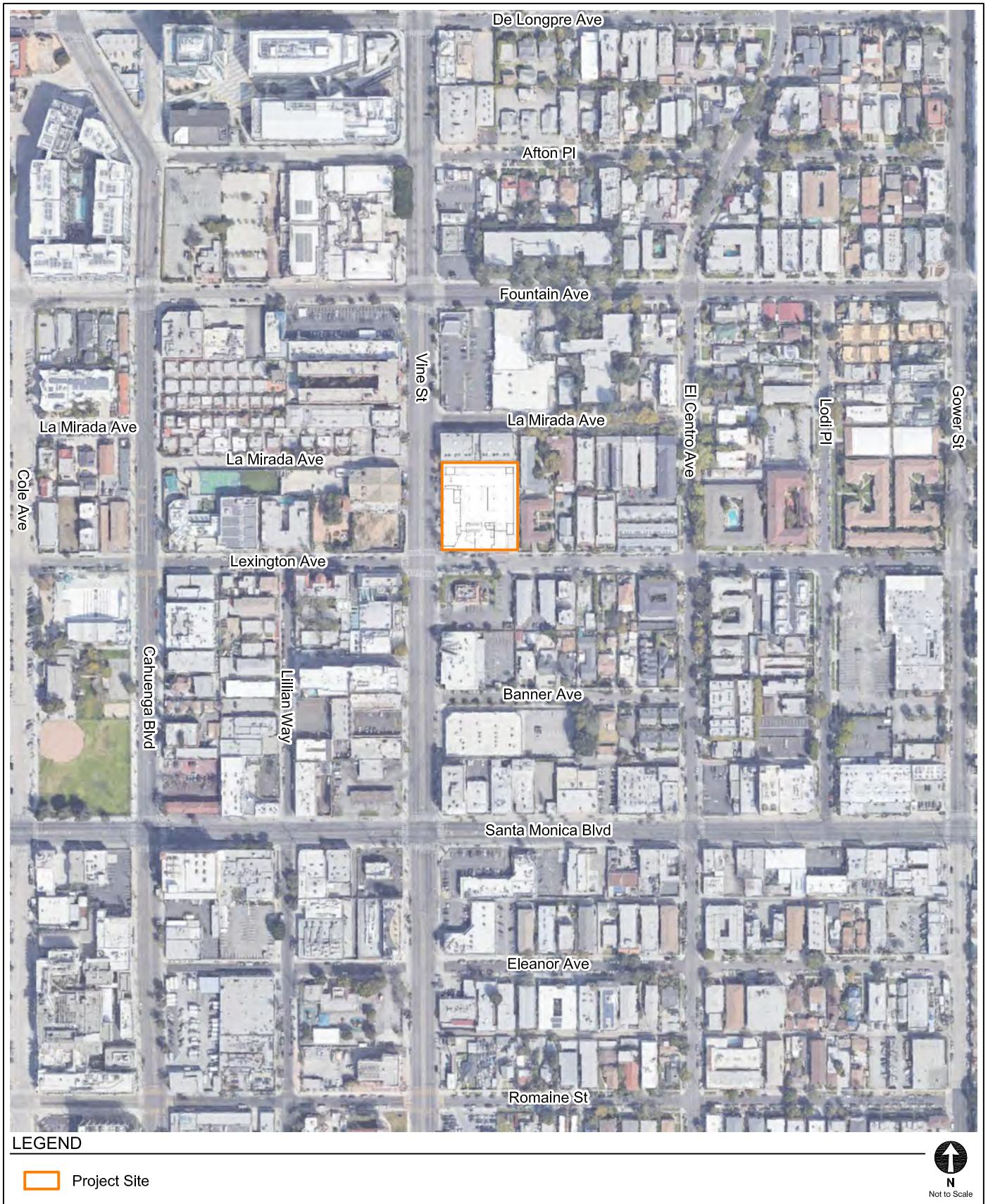

PROJECT SITE LOCATION

FIGURE
2



LEGEND

- Project Site
- Project Driveway
- # Analyzed Intersection



STUDY AREA AND ANALYZED INTERSECTIONS

**FIGURE
3**

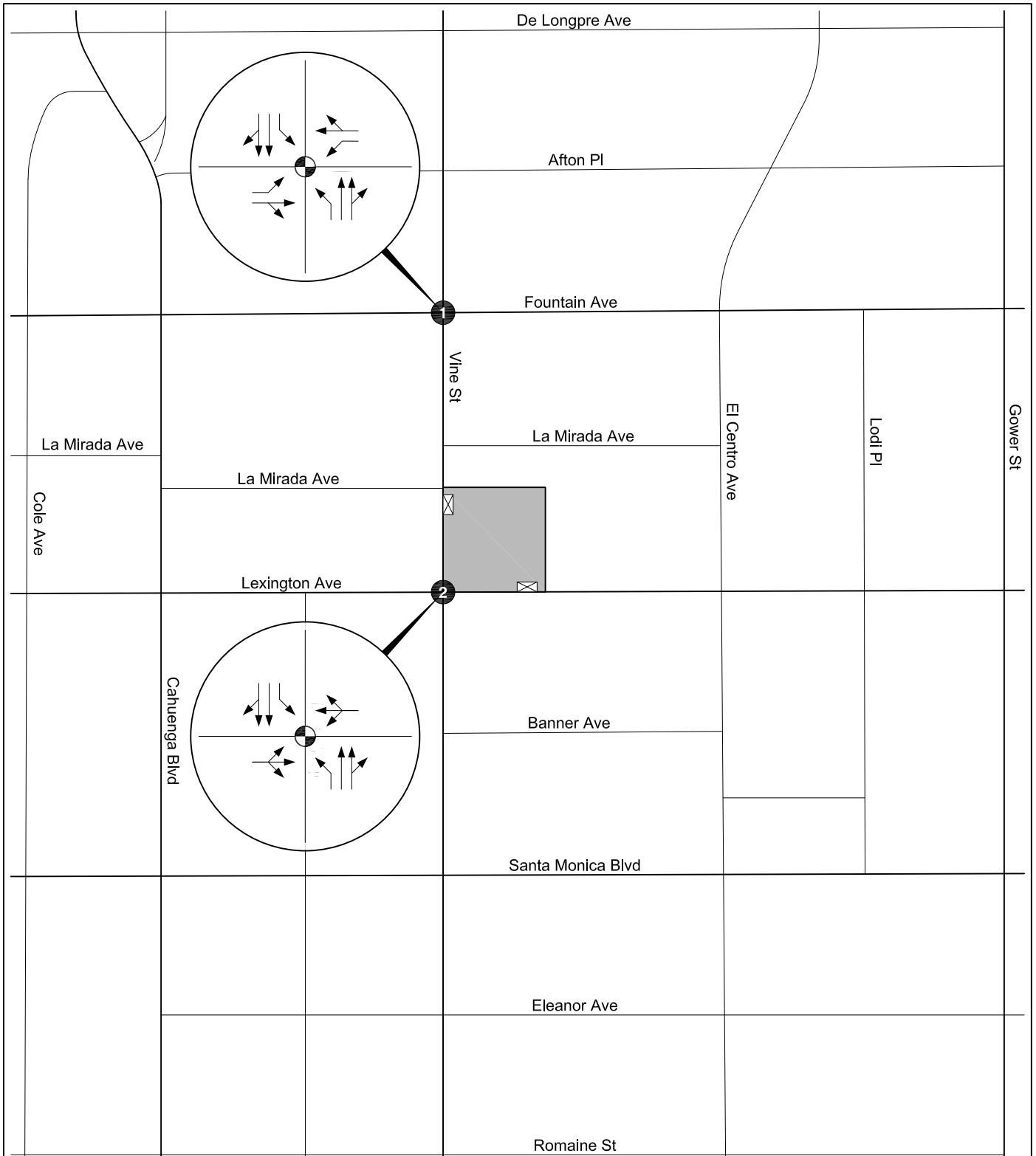

LEGEND

-  Project Site
-  Project Driveway
-  Analyzed Intersection
-  Traffic Signal







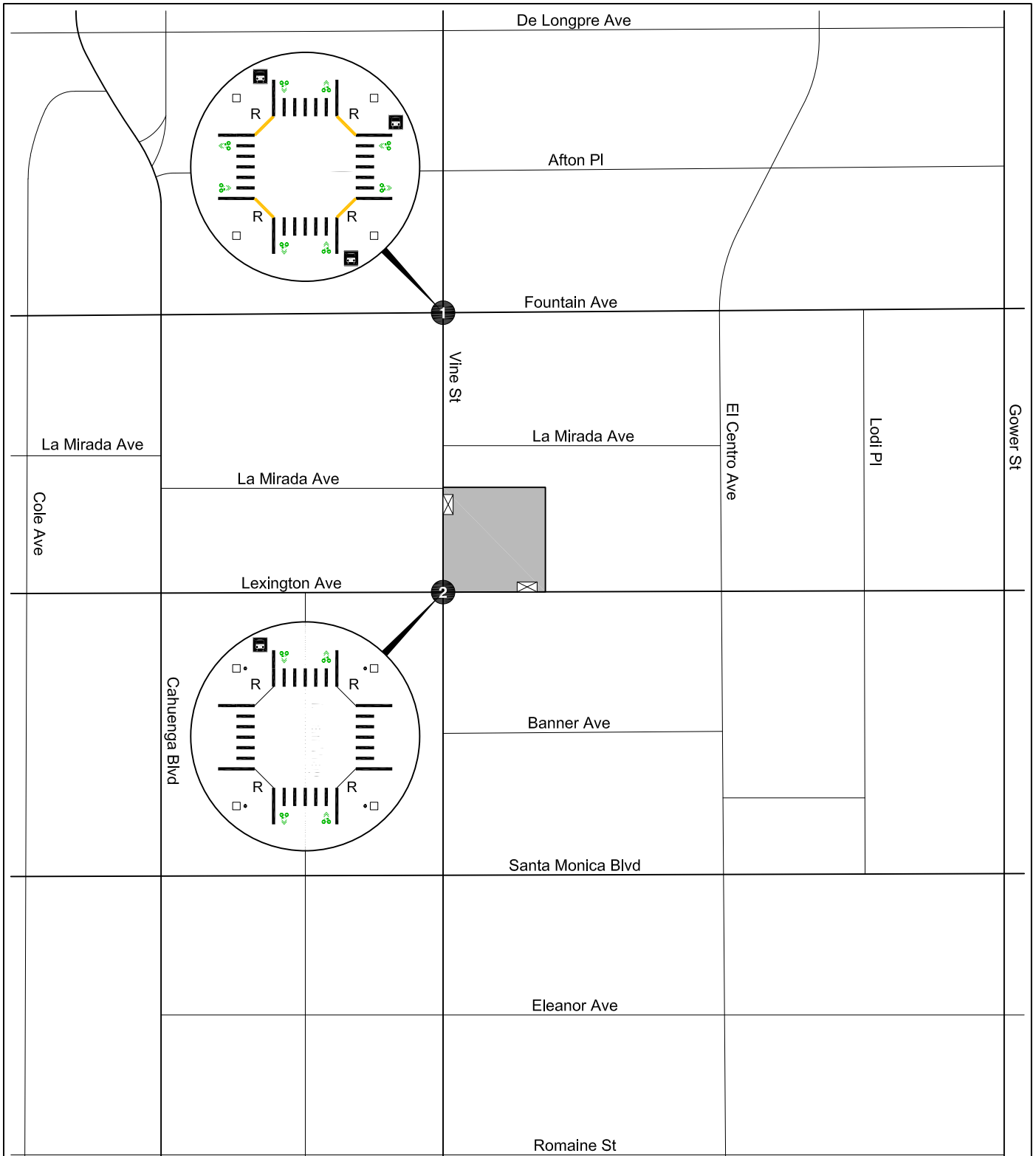





EXISTING INTERSECTION LANE CONFIGURATIONS

FIGURE
4



LEGEND

-  Project Site
-  Analyzed Intersection
-  Continental Crosswalk
-  Ramp
-  Ped Signal
-  Project Driveway
-  Bike Sharrow
-  Bus Stop
-  Tactile Curb
-  Ped Call Button



EXISTING INTERSECTION MOBILITY FACILITIES

FIGURE 5

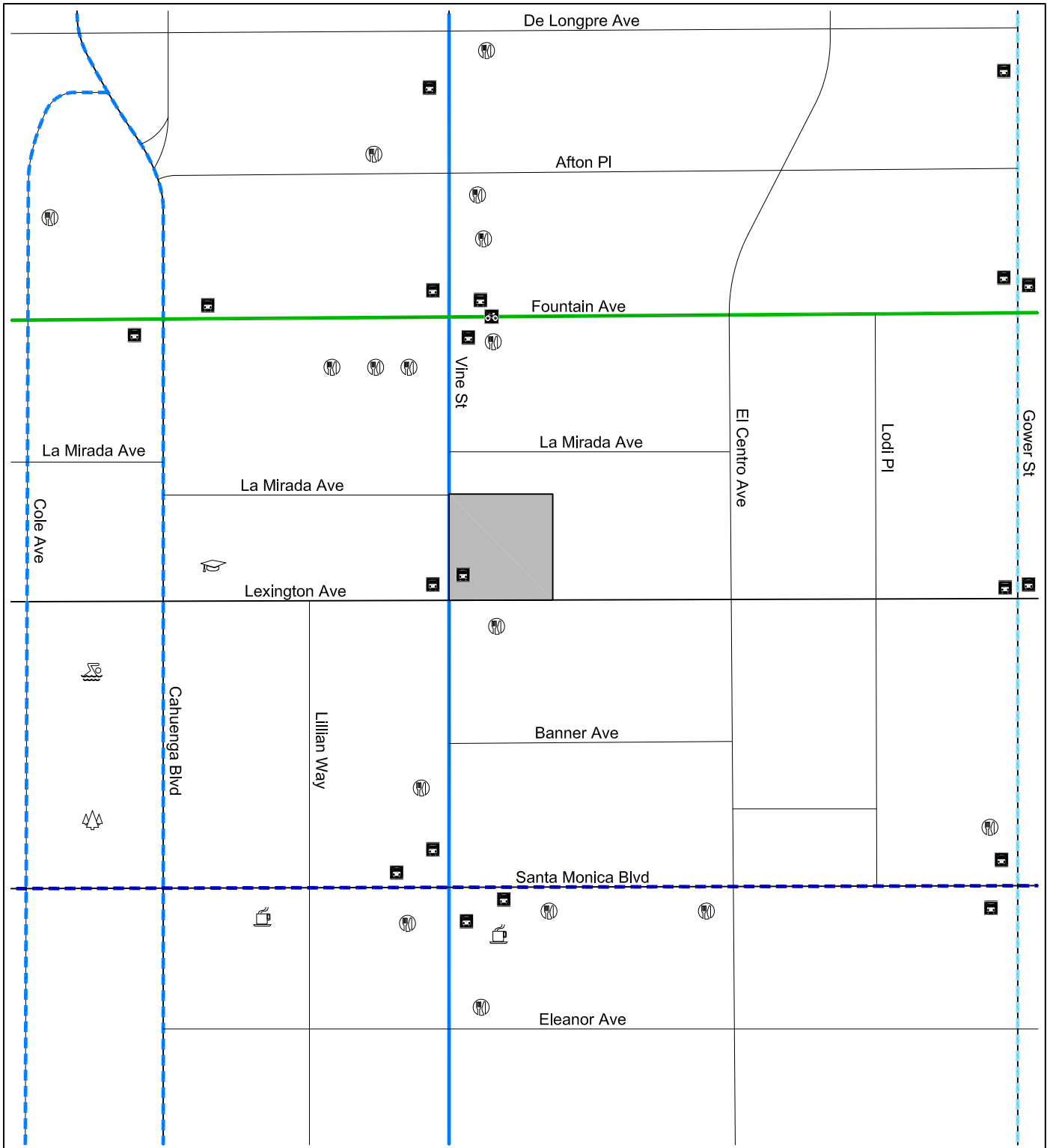

LEGEND

- | | | | | | |
|--------------|---------------|-----------|----------|--------|-------------|
| Project Site | Avenue I | Collector | Bus Stop | Dining | Public Pool |
| Avenue II | Local / Other | Bikeshare | Cafe | School | |
| Avenue III | Modified | Park | | | |



MOBILITY PLAN DESIGNATIONS AND PEDESTRIAN DESTINATIONS

FIGURE 6

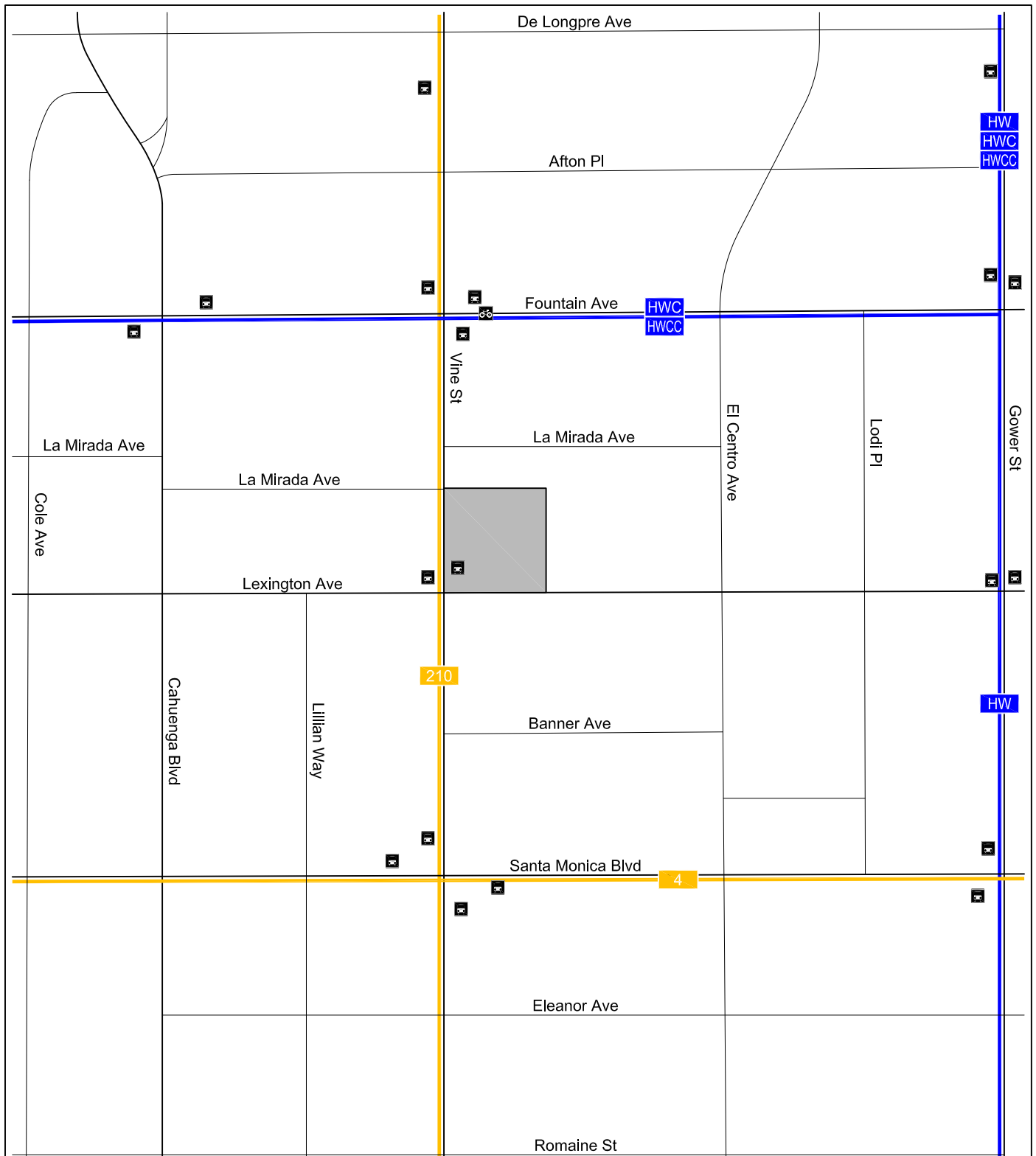

LEGEND

- Project Site
- Bus Stop
- Metro Bus
- Bikeshare
- LADOT DASH Bus





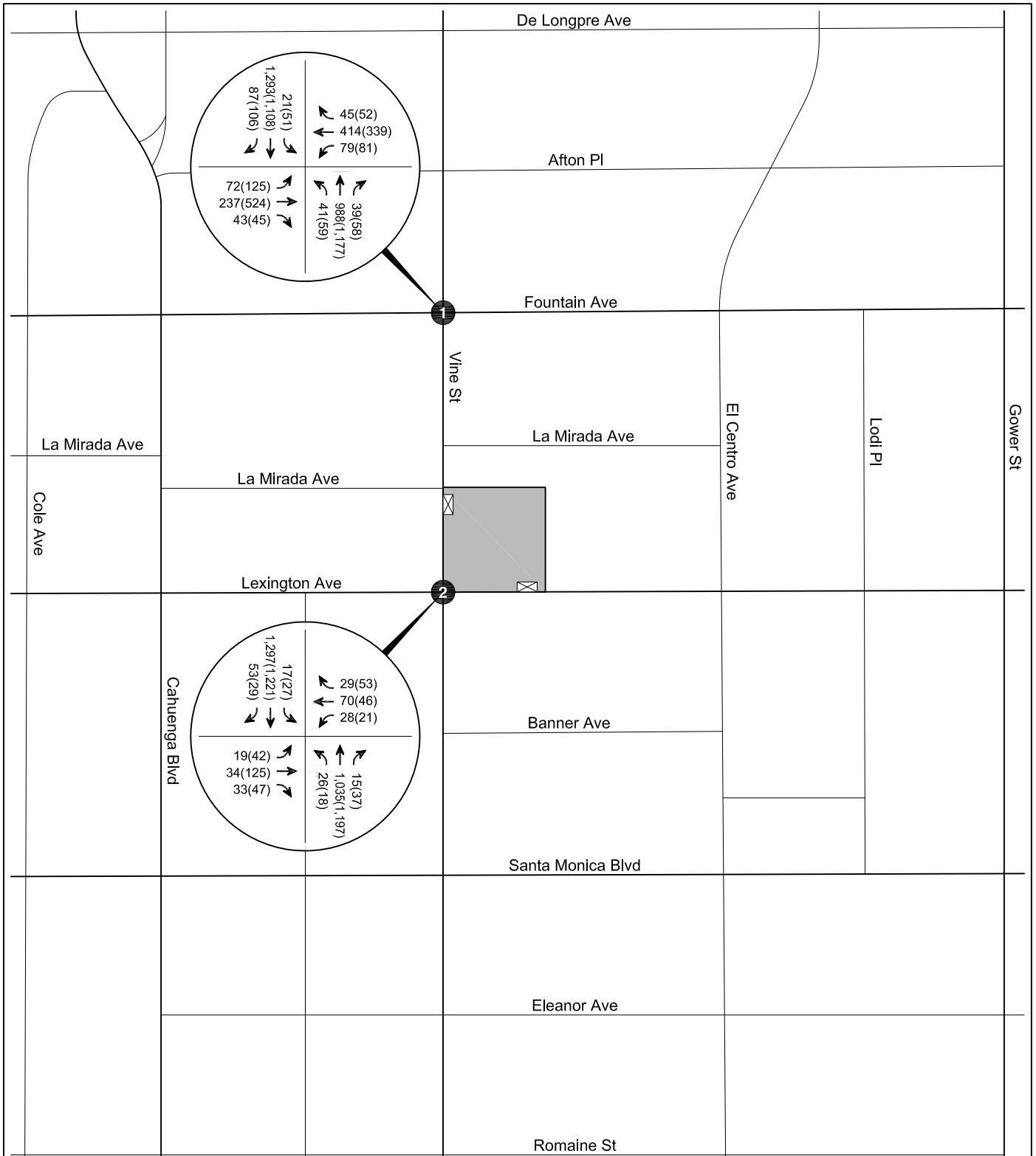

Not to Scale

EXISTING TRANSIT SERVICE

FIGURE
7



LEGEND

-  Project Site
-  Analyzed Intersection
-  #(#) AM(PM) Peak Hour Traffic Volumes
-  Project Driveway
-  * Negligible Volume



**EXISTING CONDITIONS (YEAR 2022)
PEAK HOUR TRAFFIC VOLUMES**

**FIGURE
8**



LEGEND



Project Site



Related Project



LOCATIONS OF RELATED PROJECTS

FIGURE
9

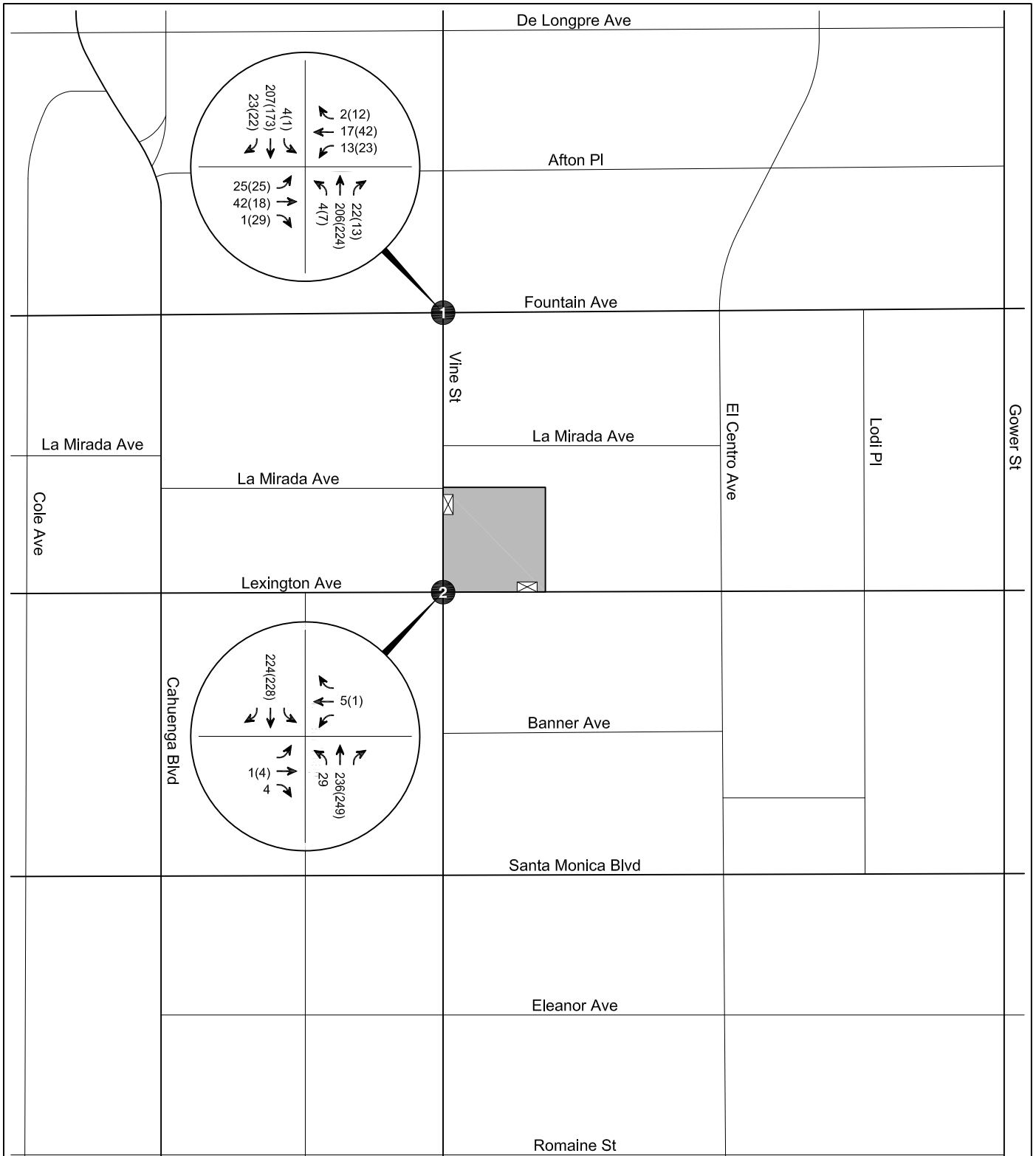

LEGEND

- Project Site
- Analyzed Intersection
- #(AM) Peak Hour Traffic Volumes
- Project Driveway





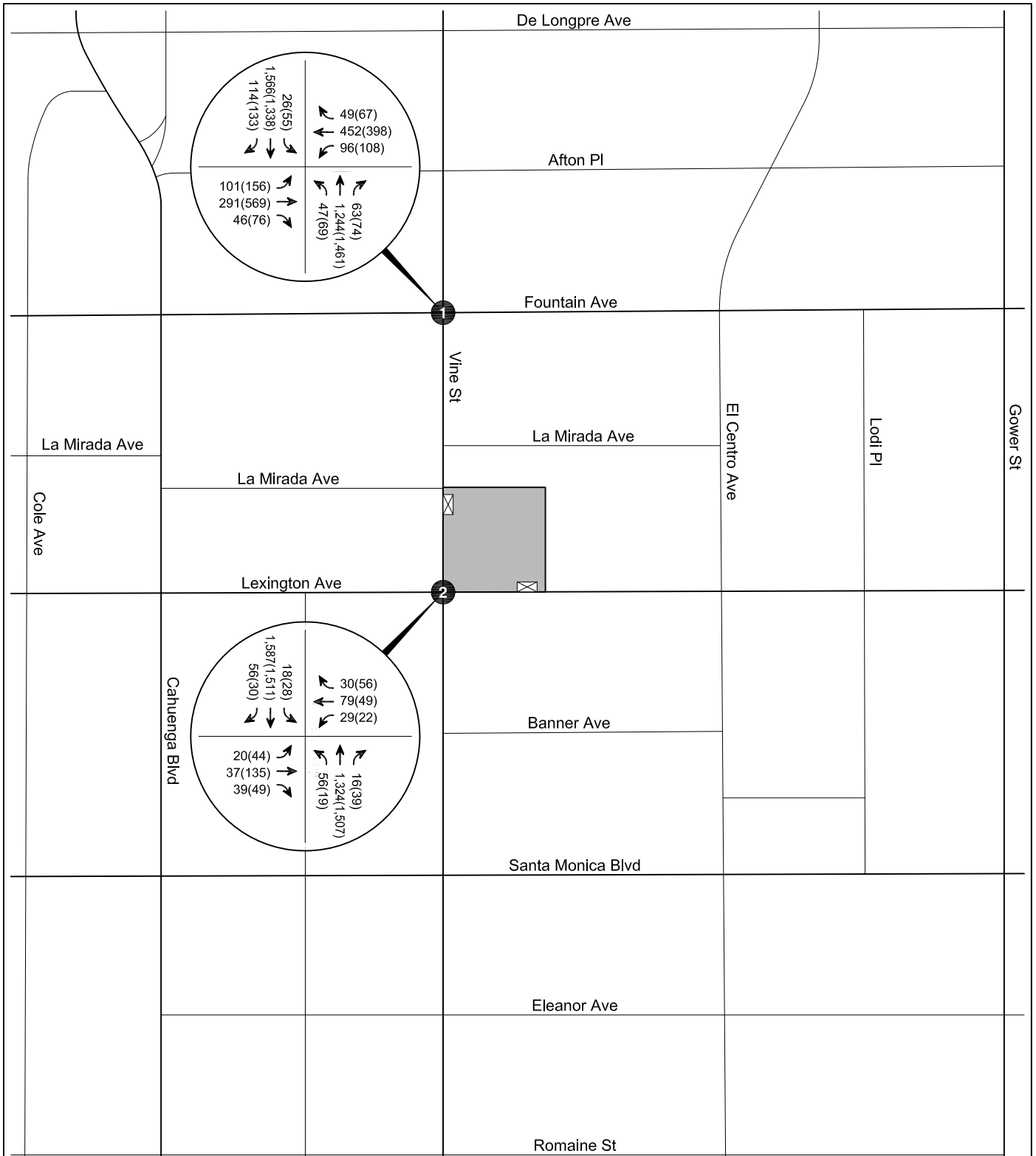

**RELATED PROJECT-ONLY
PEAK HOUR TRAFFIC VOLUMES**

**FIGURE
10**



LEGEND

-  Project Site
-  Analyzed Intersection
-  #(#) AM(PM) Peak Hour Traffic Volumes
-  Project Driveway
-  * Negligible Volume



FUTURE WITHOUT PROJECT CONDITIONS (YEAR 2027)
PEAK HOUR TRAFFIC VOLUMES

FIGURE
11



LEGEND

- Project Site
- Transit Enhanced Network
- Bicycle Lane Network
- Neighborhood Enhanced Network
- Pedestrian Enhanced District



ROADWAY MODAL PRIORITIES

FIGURE
12

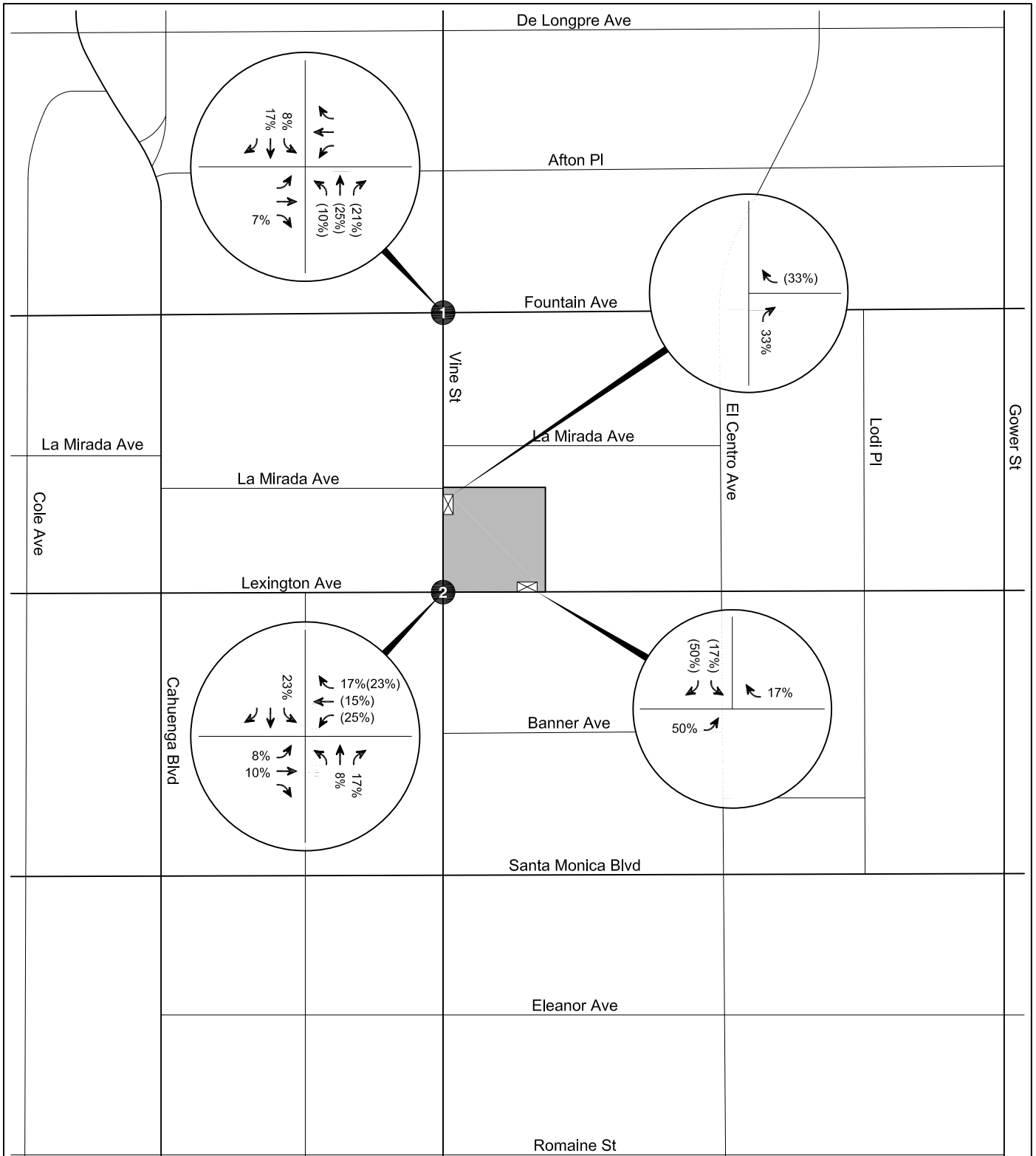

LEGEND

- Project Site
- # Analyzed Intersection
- Project Driveway
- %(%) Inbound(Outbound) Trip Percentage



**PROJECT TRIP DISTRIBUTION
RESIDENTIAL**

**FIGURE
13A**

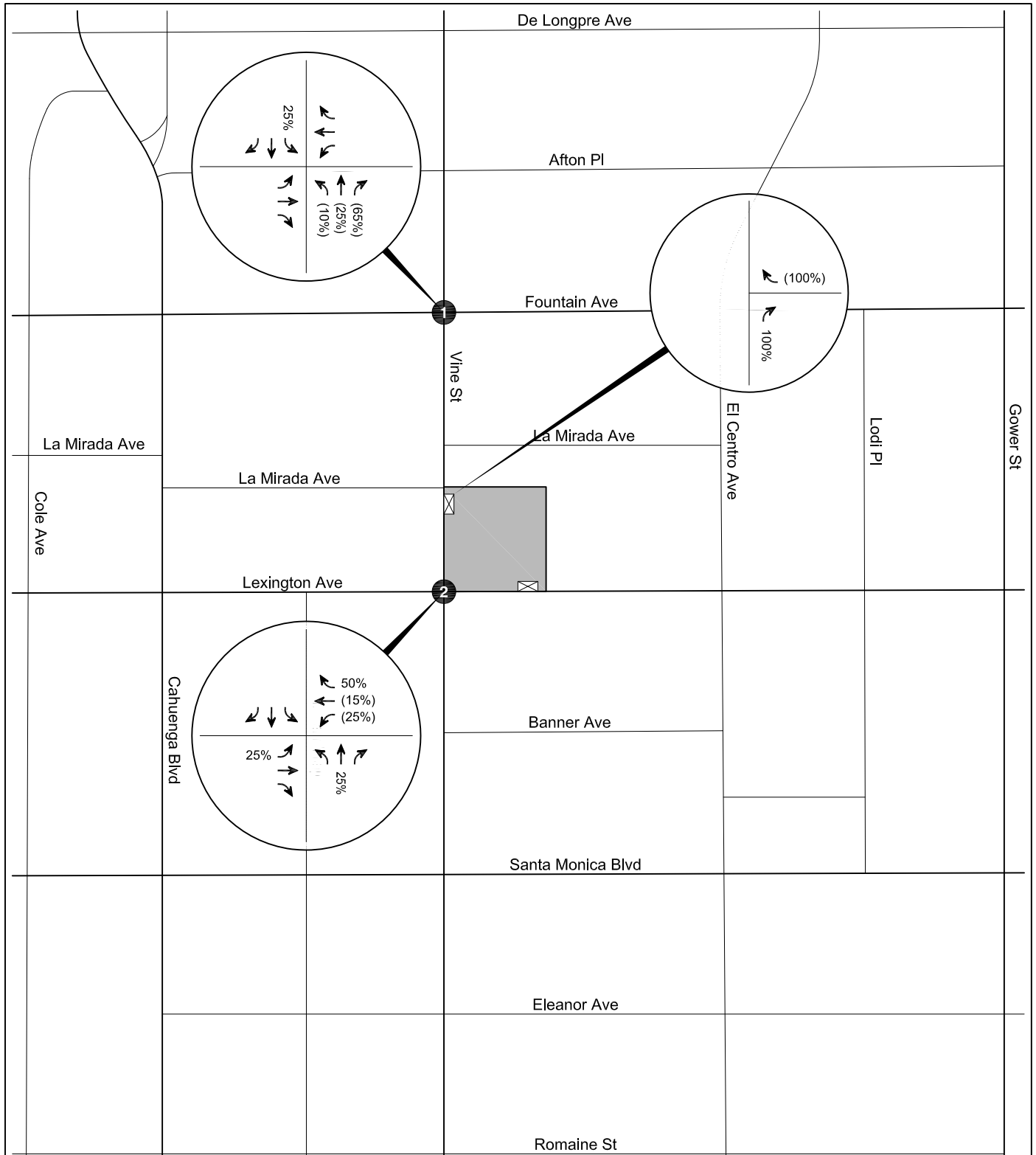

LEGEND

- Project Site
- # Analyzed Intersection
- Project Driveway
- %(%) Inbound(Outbound) Trip Percentage



**PROJECT TRIP DISTRIBUTION
COMMERCIAL**

**FIGURE
13B**

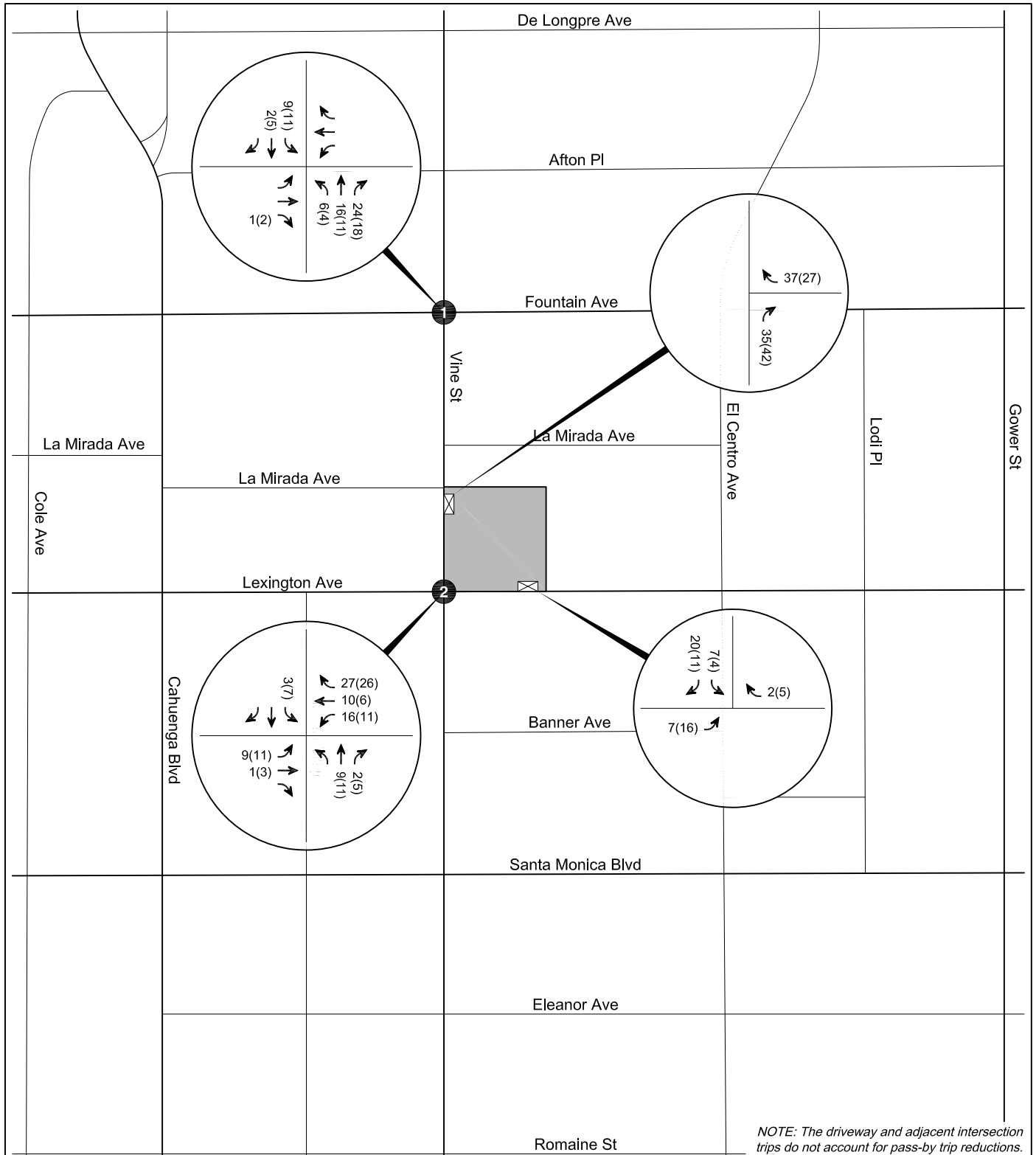

NOTE: The driveway and adjacent intersection trips do not account for pass-by trip reductions.

LEGEND

- Project Site
- Analyzed Intersection
- Project Driveway
- #(##) AM(PM) Peak Hour Traffic Volumes



**PROJECT-ONLY
PEAK HOUR TRAFFIC VOLUMES**

**FIGURE
14**

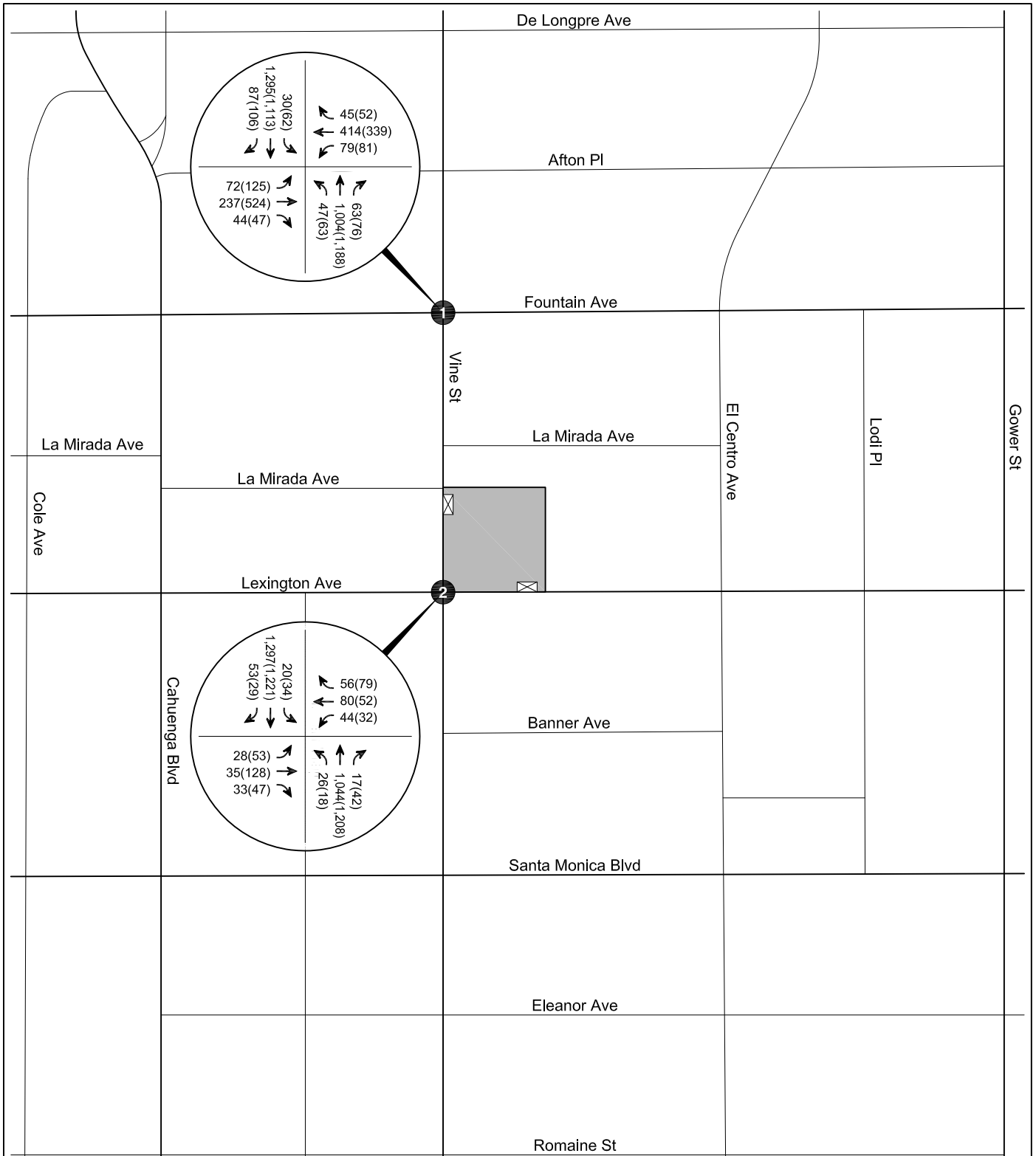

LEGEND

- Project Site
- Analyzed Intersection
- AM(PM) Peak Hour Traffic Volumes
- Project Driveway
- Negligible Volume



**EXISTING WITH PROJECT CONDITIONS (YEAR 2022)
PEAK HOUR TRAFFIC VOLUMES**

**FIGURE
15**

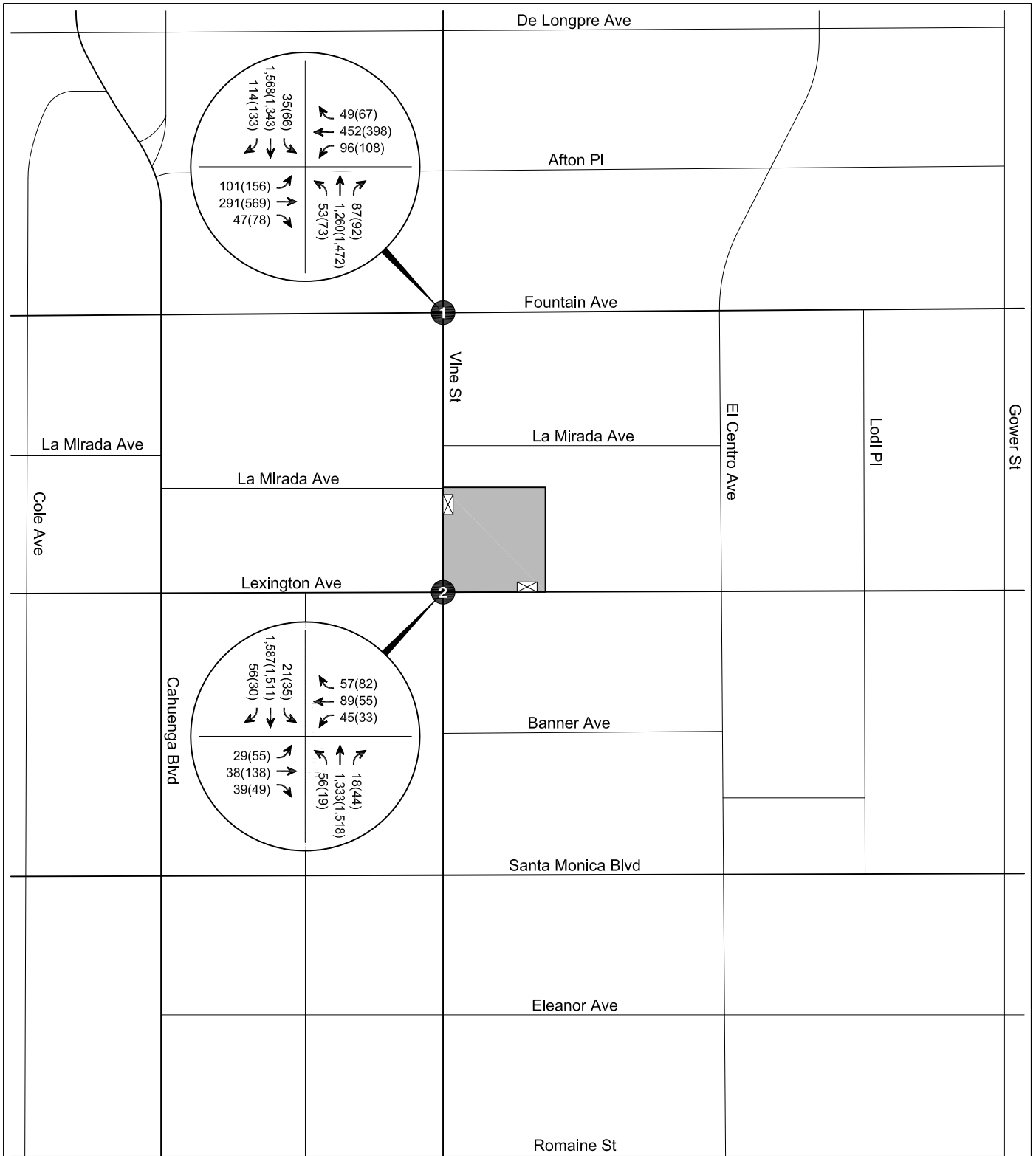

LEGEND

- Project Site
- Analyzed Intersection
- #(#) AM(PM) Peak Hour Traffic Volumes
- Project Driveway
- * Negligible Volume



**FUTURE WITH PROJECT CONDITIONS (YEAR 2027)
PEAK HOUR TRAFFIC VOLUMES**

**FIGURE
16**

**TABLE 1
EXISTING TRANSIT SERVICE IN STUDY AREA**

Provider, Route, and Service Area	Service Type	Hours of Operation	Nearest Stop Location		Average Headway (minutes)			
			Intersection	Distance to Project Site	Morning Peak Hour		Afternoon Peak Hour	
Metro Bus Service [a]					NB/EB	SB/WB	NB/EB	SB/WB
4 Downtown Los Angeles- Santa Monica via Santa Monica Blvd	Local	24 Hours	Santa Monica at Vine	680 feet south	8	8	8	8
210 Hollywood/Vine Station- South Bay Galleria Via Vine St, Wilshire/Western Station, Crenshaw Blvd	Local	4:30 A.M. to 3 A.M.	Vine at Lexington	Adjacent west	10	10	10	10
LADOT DASH Bus Service [b]					NB/EB	SB/WB	NB/EB	SB/WB
HWC Hollywood Clockwise	Local	6 A.M. to 8 P.M.	Fountain at Vine	430 feet north	N/A	30	N/A	30
HWCC Hollywood Counterclockwise	Local	6 A.M. to 8 P.M.	Fountain at Vine	430 feet north	30	N/A	30	N/A
HW Hollywood/Wilshire	Local	6 A.M. to 7:15 P.M.	Gower at Lexington	1,060 feet east	30	N/A	30	N/A

Notes:

Metro - Los Angeles County Metropolitan Transportation Authority. LADOT DASH - Los Angeles Department of Transportation Downtown Area Short Hop.

NB - Northbound. EB - Eastbound. SB - Southbound. WB - Westbound.

[a] Transit routes and frequencies based on Metro schedules effective October 23, 2022.

[b] Transit routes and frequencies based on LADOT DASH schedules effective August 3, 2020 for Hollywood and July 31, 2021 for Hollywood/Wilshire.

**TABLE 2A
TRANSIT SYSTEM CAPACITY IN STUDY AREA - MORNING PEAK HOUR**

Provider, Route, and Stop Location	Capacity per Trip [a]	Peak Hour Ridership [b]				Average Remaining Capacity per Trip		Average Remaining Peak Hour Capacity	
		Peak Load		Average Load		NB/EB	SB/WB	NB/EB	SB/WB
		NB/EB	SB/WB	NB/EB	SB/WB				
<i>Metro Bus Service</i>									
4 Santa Monica at Vine	50	21	43	15	29	35	21	263	164
210 Vine at Lexington	50	21	31	17	14	33	36	191	209
<i>LADOT DASH Bus Service</i>									
HWC Fountain at Vine	30	N/A	2	N/A	1	N/A	29	N/A	58
HWCC Fountain at Vine	30	3	N/A	2	N/A	28	N/A	56	N/A
HW Gower at Lexington	30	4	N/A	2	N/A	28	N/A	56	N/A
Total Remaining Peak Hour Transit System Capacity								997	

Notes:

Metro - Los Angeles County Metropolitan Transportation Authority. LADOT DASH - Los Angeles Department of Transportation Downtown Area Short Hop.

NB - Northbound. EB - Eastbound. SB - Southbound. WB - Westbound.

[a] Capacity assumptions:

Metro Bus - 40 seated / 50 standing

LADOT DASH Bus - 25 seated / 30 standing

Metro B Line - 55 seats / car, 6 cars / run during peak periods. Metro assumes a maximum capacity of 230% of seated capacity, or approximately 125 / car.

[b] Based on ridership data provided by Metro Bus and LADOT in 2019 and Metro Rail in 2018 to reflect pre-COVID ridership conditions.

**TABLE 2B
TRANSIT SYSTEM CAPACITY IN STUDY AREA - AFTERNOON PEAK HOUR**

Provider, Route, and Stop Location	Capacity per Trip [a]	Peak Hour Ridership [b]				Average Remaining Capacity per Trip		Average Remaining Peak Hour Capacity	
		Peak Load		Average Load		NB/EB	SB/WB	NB/EB	SB/WB
		NB/EB	SB/WB	NB/EB	SB/WB				
<i>Metro Bus Service</i>									
4 Santa Monica at Vine	50	44	31	32	21	18	23	144	186
210 Vine at Lexington	50	19	30	17	25	34	17	201	95
<i>LADOT DASH Bus Service</i>									
HWC Fountain at Vine	30	N/A	4	N/A	2	N/A	28	N/A	56
HWCC Fountain at Vine	30	3	N/A	1	N/A	29	N/A	46	N/A
HW Gower at Lexington	30	10	N/A	3	N/A	27	N/A	43	N/A
Total Remaining Peak Hour Transit System Capacity								771	

Notes:

Metro - Los Angeles County Metropolitan Transportation Authority. LADOT DASH - Los Angeles Department of Transportation Downtown Area Short Hop.

NB - Northbound. EB - Eastbound. SB - Southbound. WB - Westbound.

[a] Capacity assumptions:

Metro Bus - 40 seated / 50 standing

LADOT DASH Bus - 25 seated / 30 standing

Metro B Line - 55 seats / car, 6 cars / run during peak periods. Metro assumes a maximum capacity of 230% of seated capacity, or approximately 125 / car.

[b] Based on ridership data provided by Metro Bus and LADOT in 2019 and Metro Rail in 2018 to reflect pre-COVID ridership conditions.

**TABLE 3
RELATED PROJECTS**

No.	Project	Address	Use	Trip Generation [a]						
				Daily	Morning Peak Hour			Afternoon Peak Hour		
					In	Out	Total	In	Out	Total
1.	Seward St Office	956 N Seward St	126,980 sf office	1,240	165	21	186	29	151	180
2.	Palladium Residences	6201 W Sunset Bl	731 apartment units, including 37 affordable units, and 24,000 sf commercial	4,913	128	228	356	234	160	403
3. [b]	6250 Sunset (Nickelodeon)	6250 W Sunset Bl	200 apartment units and 4,700 sf retail	1,473	52	80	132	71	50	121
4.	Cahuenga Boulevard Hotel	1525 N Cahuenga Bl	64 hotel rooms, 3,300 sf restaurant, 1,200 sf guest lounge, and 700 sf rooftop restaurant	469	10	12	22	20	14	34
5. [b]	Mixed-Use	901 N Vine St	70 apartment units and 3,000 sf commercial	(32)	4	26	30	(5)	1	(4)
6. [b]	Mixed-Use	1310 N Cole Ave	369 apartment units, including 12 live-work and 20 affordable housing units, and 2,570 sf office	2,226	20	139	159	139	58	197
7.	Ivar Gardens Hotel	6409 W Sunset Bl	275 hotel rooms and 1,900 sf retail	1,285	51	26	77	53	60	113
8. [b]	6200 W Sunset Boulevard	6200 W Sunset Bl	270 apartment units, 8,070 sf retail, 2,300 sf pharmacy, and 1,750 sf quality restaurant	1,778	26	97	123	100	35	135
9. [b]	Academy Square	1341 Vine St	200 apartment units and 301,854 sf restaurant/office	6,218	330	164	494	152	220	372
10. [b]	Thompson Hotel	1541 N Wilcox Ave	200 hotel rooms, 5,125 sf ground floor restaurant and 4,105 sf rooftop restaurant/bar/lounge	2,058	76	57	133	82	75	157
11. [b]	Godfrey Hotel	1400 N Cahuenga Bl	220 hotel rooms, 2,723 sf restaurant, and 1,440 sf bar	1,875	55	47	102	78	60	138
12.	Selma-Wilcox hotel	6421 W Selma Ave	114 hotel rooms and 1,993 sf restaurant	1,227	43	27	70	56	44	100
13.	6400 Sunset Mixed-Use	6400 W Sunset Bl	200 apartment units and 7,000 sf restaurant	11	14	77	91	57	(6)	51
14.	Modera Argyle	1546 N Argyle Ave	276 apartment units, including 13 affordable housing units, 15,000 sf restaurant, and 9,000 sf retail	2,013	43	127	170	128	51	179
15.	Citizen News	1545 N Wilcox Ave	16,100 sf flexible event space and 14,800 sf restaurant	2,341	36	50	86	128	47	175

Notes:

[a] Related project information provided by the Los Angeles Department of Transportation and Los Angeles Department of City Planning in June 2022 and recent traffic studies prepared in the area. This list includes known development projects within one-half mile (2,460 foot) radius of the Project Site in accordance with the TAG.

[b] Although construction of the related project may be partially complete/entirely complete, the project was not fully occupied at the time when traffic counts were conducted. Therefore, the related project was considered and listed to provide a more conservative analysis.

**TABLE 3
RELATED PROJECTS (CONT.)**

No.	Project	Address	Use	Trip Generation [a]						
				Daily	Morning Peak Hour			Afternoon Peak Hour		
					In	Out	Total	In	Out	Total
16.	Sunset Gower Studios	1438 N Gower St	828,339 sf office, 205,202 sf sound stage, 65,319 sf production support, and 6,516 sf restaurant	4,108	424	67	491	77	410	487
17. [b]	Sunset and Gordon Mixed-Use	5939 W Sunset Bl	299 apartment units, including 15 affordable housing units, 38,440 sf office, 3,700 sf restaurant, and 3,970 sf retail	3,731	152	191	343	182	152	334
18.	1400 Vine	1400 Vine St	198 apartment units, including 21 affordable housing units, and 16,000 sf restaurant	1,446	70	93	163	97	56	153
19.	6445 Sunset	6445 Sunset Bl	175 hotel rooms and 12,500 sf restaurant	1,409	77	58	135	80	61	141
20.	Wilcox & Selma Residential	6422 W Selma Ave	40 apartment units and 5 affordable housing units	126	(3)	10	7	9	(1)	8
21.	Artisan Hollywood	1520 N Cahuenga Bl	270 apartment units, including 27 affordable housing units and 6,805 sf restaurant	1,143	34	75	109	82	40	122
22.	Sunset + Wilcox Mixed-Use	6450 W Sunset Bl	431,032 sf office, and 12,386 sf restaurant	2,836	311	50	361	93	319	412
23.	Residential with Affordable Housing	1125 N Gower St	155 apartment units and 14 affordable housing units	667	13	35	48	32	21	53
24.	Sunset Vine 2	6266 W Sunset Bl	150 apartment units and 13,130 sf restaurant	603	11	35	46	33	22	55
25.	1000 Seward	1000 N Seward St	136,200 sf office, 12,200 sf restaurant, and 2,200 sf retail	1,669	147	48	195	58	135	193
26.	6007 Sunset Mixed-Use	6007 W Sunset Bl	110 apartment units and 14,555 sf retail	904	15	25	40	30	29	59
27. [b]	Hollywood Center Studios Office	6601 W Romaine St	106,125 sf office	808	88	4	92	12	39	51
28.	1235 Vine St	1235 Vine St	109,190 sf office and 7,960 sf restaurant	696	96	19	116	19	91	108
29.	Hollywood Production Center	1149 N Gower St	169 apartment units	735	6	23	29	23	12	35
30.	Onni Group Mixed-Use Development	1360 N Vine St	463,521 sf office, 11,914 sf restaurant and 8,998 sf additional restaurant	3,533	278	40	318	135	337	472

Notes:

[a] Related project information provided by the Los Angeles Department of Transportation and Los Angeles Department of City Planning in June 2022 and recent traffic studies prepared in the area. This list includes known development projects within one-half mile (2,460 foot) radius of the Project Site in accordance with the TAG.

[b] Although construction of the related project may be partially complete/entirely complete, the project was not fully occupied at the time when traffic counts were conducted. Therefore, the related project was considered and listed to provide a more conservative analysis.

**TABLE 4
TRIP GENERATION ESTIMATES**

Land Use	ITE Land Use	Rate or Size	Morning Peak Hour			Afternoon Peak Hour		
			In	Out	Total	In	Out	Total
TRIP GENERATION RATES [a]								
Multi-Family Housing (Mid-Rise)	221	per du	23%	77%	0.37	61%	39%	0.39
Affordable Housing	[b]	per du	37%	63%	0.49	56%	44%	0.35
High-Turnover (Sit-Down) Restaurant	932	per 1,000 sf	55%	45%	9.57	61%	39%	9.05
TRIP GENERATION ESTIMATES								
<u>Proposed Project</u>								
Multi-Family Housing (Mid-Rise)	221	135 du	12	38	50	32	21	53
<i>Transit/Walk-In Reduction - 10% [c]</i>			(1)	(4)	(5)	(3)	(2)	(5)
Affordable Housing	[b]	18 du	3	6	9	3	3	6
Restaurant	932	7,000 sf	37	30	67	38	25	63
<i>Internal Capture Reduction - 10% [d]</i>			(4)	(3)	(7)	(4)	(3)	(7)
<i>Transit/Walk-In Reduction - 10% [c]</i>			(3)	(3)	(6)	(3)	(2)	(5)
<i>Pass-By Trip Reduction - 20% [e]</i>			(6)	(5)	(11)	(6)	(4)	(10)
TOTAL NEW PROJECT TRIPS			38	59	97	57	38	95

Notes:

du = dwelling unit; sf = square feet

[a] Trip generation rates are for General Urban/Suburban areas from *Trip Generation Manual, 11th Edition* (Institute of Transportation Engineers, 2021), unless otherwise noted.

[b] Per LADOT's *Transportation Assessment Guidelines*, residential or mixed-use developments inside a Transit Priority Area (TPA) which include Affordable Housing Units are eligible to use a City-specific trip generation rate based on vehicle trip count data collected at affordable housing sites in the City of Los Angeles in 2016.

[c] Per LADOT's *Transportation Assessment Guidelines*, the Project Site is located within 0.25 miles from bus stops that serve Metro Local and LADOT DASH lines, thus a 10% transit reduction was applied to account for transit usage and walking visitor arrivals from the surrounding neighborhoods and adjacent commercial developments.

[d] Internal capture reductions account for person trips made between distinct land uses within a mixed-use development (i.e., residents visiting the commercial uses).

[e] Per Attachment H of LADOT's *Transportation Assessment Guidelines*, pass-by reductions were taken into account for Project trips made as an intermediate stop on the way from an origin to a primary trip destination without route diversion.

**TABLE 5
VMT ANALYSIS SUMMARY**

Project Information	
Land Use	Size
Multi-Family Housing	135 du
Affordable Housing	18 du
High-Turnover (Sit-Down) Restaurant	7,000 sf
Project Analysis [a]	
Resident Population	361
Employee Population	28
Project Area Planning Commission	Central
Travel Behavior Zone (TBZ)	Urban
Maximum Allowable VMT Reduction [b]	75%
VMT Analysis [c] [d]	
Daily Vehicle Trips	892
Total Daily VMT	5,297
Total Home-Based Production VMT	1,320
Household VMT per Capita [e]	3.7
Impact Threshold	6.0
Significant Impact	NO

Notes:

du = dwelling units. sf = square feet.

[a] VMT results based on the *City of Los Angeles VMT Calculator Version 1.3* (July 2020).

[b] The maximum allowable VMT reduction is based on the Project's designated TBZ as determined in *Transportation Demand Management Strategies in LA VMT Calculator* (LADOT, November 2019) and *Quantifying Greenhouse Gas Mitigation Measures* (California Air Pollution Control Officers Association, 2010).

[c] Per the TAG, retail and restaurant uses totaling less than 50,000 sf would be considered local-serving and would have a negligible impact on regional VMT. Therefore, the VMT impact of the Project's commercial component would be considered less-than-significant.

[d] Reduced parking supply and the provision of bike parking per LAMC are included as Project design features.

[e] Based on home-based production trips only (see Appendix D, Report 4).

**TABLE 6
INTERSECTION LEVEL OF SERVICE**

Level of Service	Description	Delay [a]
		Signalized Intersections
A	EXCELLENT. No vehicle waits longer than one red light and no approach phase is fully used.	≤ 10
B	VERY GOOD. An occasional approach phase is fully utilized; many drivers begin to feel somewhat restricted within groups of vehicles.	> 10 and ≤ 20
C	GOOD. Occasionally drivers may have to wait through more than one red light; backups may develop behind turning vehicles.	> 20 and ≤ 35
D	FAIR. Delays may be substantial during portions of the rush hours, but enough lower volume periods occur to permit clearing of developing lines, preventing excessive backups.	> 35 and ≤ 55
E	POOR. Represents the most vehicles intersection approaches can accommodate; may be long lines of waiting vehicles through several signal cycles.	> 55 and ≤ 80
F	FAILURE. Backups from nearby locations or on cross streets may restrict or prevent movement of vehicles out of the intersection approaches. Tremendous delays with continuously increasing queue lengths.	> 80

Notes:

Source: *Highway Capacity Manual, 6th Edition* (Transportation Research Board, 2016).

[a] Measured in seconds.

**TABLE 7
EXISTING CONDITIONS (YEAR 2022)
INTERSECTION LEVELS OF SERVICE**

No	Intersection [a]	Peak Hour	Existing Conditions		Existing with Project Conditions	
			Delay	LOS	Delay	LOS
1.	Vine Street & Fountain Avenue	AM	18.2	B	18.2	B
		PM	20.3	C	20.5	C
2.	Vine Street & Lexington Avenue	AM	5.5	A	6.7	A
		PM	8.0	A	8.8	A

Notes:

Delay is measured in seconds per vehicle. LOS = Level of Service.

[a] Intersection analysis based on HCM 6th Edition Signalized methodology, which calculates the average intersection delay, in seconds, for each vehicle passing through the intersection.

**TABLE 8
FUTURE CONDITIONS (YEAR 2027)
INTERSECTION LEVELS OF SERVICE**

No	Intersection [a]	Peak Hour	Future without Project Conditions		Future with Project Conditions	
			Delay	LOS	Delay	LOS
1.	Vine Street & Fountain Avenue	AM	32.2	C	32.7	C
		PM	36.3	D	38.0	D
2.	Vine Street & Lexington Avenue	AM	6.1	A	7.5	A
		PM	9.0	A	9.9	A

Notes:

Delay is measured in seconds per vehicle. LOS = Level of Service.

[a] Intersection analysis based on HCM 6th Edition Signalized methodology, which calculates the average intersection delay, in seconds, for each vehicle passing through the intersection.

**TABLE 9
QUEUING ANALYSIS - FUTURE CONDITIONS (YEAR 2027)**

No.	Intersection [a]	Future with Project Conditions					Lane	Vehicle Storage Capacity (ft) [d]	Future without Project Conditions (Year 2027)				Future with Project Conditions (Year 2027)				Change in Vehicle Queue Length (ft)	
		Intersection LOS [b]		Approach	Approach LOS [c]				Morning Peak Hour		Afternoon Peak Hour		Morning Peak Hour		Afternoon Peak Hour		Morning Peak Hour [f]	Afternoon Peak Hour [f]
		Morning Peak Hour	Afternoon Peak Hour		Morning Peak Hour	Afternoon Peak Hour			Vehicle Queue Length (ft)	Exceeds Capacity?	Vehicle Queue Length (ft)	Exceeds Capacity?	Vehicle Queue Length (ft)	Exceeds Capacity?	Vehicle Queue Length (ft)	Exceeds Capacity?		
		[e]			[e]				[e]		[e]		[e]					
1.	Fountain Avenue & Vine Street	C	D	EB	-	D	Left	130	143	YES	203	YES	143	YES	203	YES	--	--
				Through	575	260	NO	655	YES	263	NO	660	YES	--	--			
				WB	-	E	Left	220	95	NO	293	YES	95	NO	295	YES	--	--
				Through	565	445	NO	353	NO	445	NO	353	NO	--	--			
				NB	-	C	Left	165	75	NO	110	NO	90	NO	120	NO	--	--
				Through	250	433	YES	218	NO	458	YES	248	NO	25	30			
				SB	-	D	Left	170	28	NO	53	NO	40	NO	75	NO	--	--
				Through	270	743	YES	630	YES	745	YES	638	YES	--	--			
2.	Lexington Avenue & Vine Street	A	A	NB	-	-	Left	100	15	NO	5	NO	20	NO	8	NO	--	--
				Through	80	3	NO	10	NO	5	NO	15	NO	--	--			
				SB	-	-	Left	80	3	NO	10	NO	5	NO	--	--		
				Through	80	3	NO	10	NO	5	NO	15	NO	--	--			

Notes:

LOS: Level of Service

Results per Synchro 11.

[a] Per TAG Section 3.3.3, projects must be evaluated for unacceptable queuing at turn-pockets on an Avenue or Boulevard at project driveway(s) or at nearby signalized intersections.

[b] If the projected peak hour intersection LOS is D, E, or F (See Table 13 - Future Conditions (Year 2026) Intersection Levels of Service), evaluation of unacceptable queuing at through lanes is also required.

[c] Directional approach LOS included for locations where through lane queue evaluation is required.

[d] Vehicle storage capacity reflects turn pocket lengths (left/right-turn lanes) and distance between the intersection and the nearest cross street or alley (through lanes).

[e] Vehicle queue lengths were converted to feet (ft) by multiplying 25-feet per reported vehicle length.

[f] Changes in vehicle queue lengths of less than 25 feet (1 vehicle length) are negligible.

**TABLE 10
VEHICLE CODE PARKING REQUIREMENTS**

Land Use	Size	Parking Rate	Total Spaces
Residential [a]	153 du	0.50 sp / 1 du	77
Commercial Retail/Restaurant [b]	7,000 sf	2.00 sp / 1,000 sf	14
Total Parking Requirement			91

Notes:

- [a] Residential parking requirement in accordance with AB 2345 standards (Government Code Section 65915) which requires no more than 0.5 parking spaces per dwelling unit.
- [b] Commercial parking requirement per LAMC Section 12.21.A.4(x)(3)(2) pursuant to the Project Site's location within a State Enterprise Zone.

**TABLE 11
BICYCLE CODE PARKING REQUIREMENTS**

Land Use	Size	Short-Term Bicycle Parking Rate [a]	Short-Term Spaces	Long-Term Bicycle Parking Rate [a]	Long-Term Spaces
Residential					
<i>First 25 units</i>	25 du	1.0 sp / 10 du	2.5 sp	1.0 sp / 1 du	25.0 sp
<i>Next 75 units</i>	75 du	1.0 sp / 15 du	5.0 sp	1.0 sp / 1.5 du	50.0 sp
<i>Next 100 units</i>	53 du	1.0 sp / 20 du	2.7 sp	1.0 sp / 2 du	26.5 sp
Commercial	7,000 sf	1.0 sp / 2,000 sf	3.5 sp	1.0 sp / 2,000 sf	3.5 sp
Total Bicycle Parking Required			14 sp		105 sp

Notes:

[a] Bicycle requirements as calculated by Section 12.21.A.16(a) of *Los Angeles Municipal Code* (City of Los Angeles, revised March 1, 2018).

Attachment A
Memorandum of Understanding

Transportation Assessment Memorandum of Understanding (MOU)

This MOU acknowledges that the Transportation Assessment for the following Project will be prepared in accordance with the latest version of LADOT’s Transportation Assessment Guidelines:

I. PROJECT INFORMATION

Project Name: 1200 Vine Project

Project Address: 1200, 1204, 1214, 1218 N Vine St, 6245, 6247 W Lexington Ave, Los Angeles, CA 90038

Project Description: The Project proposes 153 multi-family residential uses, including 18 affordable units, and 7,000 sf of commercial uses.

LADOT Project Case Number: CEN22-53727 Project Site Plan attached? (Required) Yes No

II. TRANSPORTATION DEMAND MANAGEMENT (TDM) MEASURES

Select any of the following TDM measures, which may be eligible as a Project Design Feature¹, that are being considered for this project:

<input checked="" type="checkbox"/> Reduced Parking Supply ²	<input checked="" type="checkbox"/> Bicycle Parking and Amenities	<input type="checkbox"/> Parking Cash Out
---	---	---

List any other TDM measures (e.g. bike share kiosks, unbundled parking, microtransit service, etc.) below that are also being considered and would require LADOT staff’s determination of its eligibility as a TDM measure. LADOT staff will make the final determination of the TDM measure's eligibility for this project.

- | | |
|---------|---------|
| 1 _____ | 4 _____ |
| 2 _____ | 5 _____ |
| 3 _____ | 6 _____ |

III. TRIP GENERATION

Trip Generation Rate(s) Source: ITE 10th Edition / Other ITE 11th / LADOT TAG

Trip Generation Adjustment <i>(Exact amount of credit subject to approval by LADOT)</i>	Yes	No
Transit Usage	<input checked="" type="checkbox"/>	<input type="checkbox"/>
Existing Active or Previous Land Use	<input type="checkbox"/>	<input checked="" type="checkbox"/>
Internal Trip	<input checked="" type="checkbox"/>	<input type="checkbox"/>
Pass-By Trip	<input checked="" type="checkbox"/>	<input type="checkbox"/>
Transportation Demand Management (See above)	<input checked="" type="checkbox"/>	<input type="checkbox"/>

Trip generation table including a description of the existing and proposed land uses, rates, estimated morning and afternoon peak hour volumes (ins/outs/totals), proposed trip credits, etc. attached? (Required) Yes No

	<u>IN</u>	<u>OUT</u>	<u>TOTAL</u>
AM Trips	<u>38</u>	<u>59</u>	<u>97</u>
PM Trips	<u>57</u>	<u>38</u>	<u>95</u>

NET Daily Vehicle Trips (DVT)
_____ DVT (ITE __ ed.)
<u>1,025</u> DVT (VMT Calculator ver. 1.3)

¹ At this time Project Design Features are only those measures that are also shown to be needed to comply with a local ordinance, affordable housing incentive program, or State law.

²Select if reduced parking supply is pursued as a result of a parking incentive as permitted by the City’s Bicycle Parking Ordinance, State Density Bonus Law, or the City’s Transit Oriented Community Guidelines.

IV. STUDY AREA AND ASSUMPTIONS

Project Buildout Year: 2027 Ambient Growth Rate: 1.0 % Per Yr.

Related Projects List, researched by the consultant and approved by LADOT, attached? (Required) Yes No

STUDY INTERSECTIONS and/or STREET SEGMENTS:
 (May be subject to LADOT revision after access, safety, and circulation evaluation.)

- 1 Vine Street & Fountain Avenue 4 _____
- 2 Vine Street & Lexington Avenue 5 _____
- 3 _____ 6 _____

Provide a separate list if more than six study intersections and/or street segments.

Is this Project located on a street within the High Injury Network? Yes No

If a study intersection is located within a ¼-mile of an adjacent municipality’s jurisdiction, signature approval from said municipality is required prior to MOU approval.

V. ACCESS ASSESSMENT

- a. Does the project exceed 1,000 net DVT? Yes No
- b. Is the project’s frontage 250 linear feet or more along an Avenue or Boulevard as classified by the City’s General Plan? Yes No
- c. Is the project’s building frontage encompassing an entire block along an Avenue or Boulevard as classified by the City’s General Plan? Yes No

VI. ACCESS ASSESSMENT CRITERIA

If Yes to any of the above questions a., b., or c., complete **Attachment C.1: Access Assessment Criteria**.

VII. SITE PLAN AND MAP OF STUDY AREA

Please note that the site plan should also be submitted to the Department of City Planning for cursory review.

Does the attached site plan and/or map of study area show	Yes	No	Not Applicable
Each study intersection and/or street segment	<input checked="" type="checkbox"/>	<input type="checkbox"/>	<input type="checkbox"/>
*Project Vehicle Peak Hour trips at each study intersection	<input checked="" type="checkbox"/>	<input type="checkbox"/>	<input type="checkbox"/>
*Project Vehicle Peak Hour trips at each project access point	<input checked="" type="checkbox"/>	<input type="checkbox"/>	<input type="checkbox"/>
*Project trip distribution percentages at each study intersection	<input checked="" type="checkbox"/>	<input type="checkbox"/>	<input type="checkbox"/>
Project driveways designed per LADOT MPP 321 (show widths and directions or lane assignment)	<input checked="" type="checkbox"/>	<input type="checkbox"/>	<input type="checkbox"/>
Pedestrian access points and any pedestrian paths	<input checked="" type="checkbox"/>	<input type="checkbox"/>	<input type="checkbox"/>
Pedestrian loading zones	<input checked="" type="checkbox"/>	<input type="checkbox"/>	<input type="checkbox"/>
Delivery loading zone or area	<input checked="" type="checkbox"/>	<input type="checkbox"/>	<input type="checkbox"/>
Bicycle parking onsite	<input checked="" type="checkbox"/>	<input type="checkbox"/>	<input type="checkbox"/>
Bicycle parking offsite (in public right-of-way)	<input type="checkbox"/>	<input type="checkbox"/>	<input checked="" type="checkbox"/>

*For mixed-use projects, also show the project trips and project trip distribution by land use category.

VIII. FREEWAY SAFETY ANALYSIS SCREENING

Will the project add 25 or more trips to any freeway off-ramp in either the AM or PM peak hour? YES NO

Provide a brief explanation or graphic identifying the number of project trips expected to be added to the nearby freeway off-ramps serving the project site. If Yes to the question above, a freeway ramp analysis is required.

IX. CONTACT INFORMATION

	<u>CONSULTANT</u>	<u>DEVELOPER</u>
Name:	<u>Gibson Transportation Consulting, Inc.</u>	<u>1200 Vine Street, Los Angeles Apartments, LLC</u>
Address:	<u>555 W. 5th Street, Suite 3375, Los Angeles, CA 90013</u>	<u>4601 Park Road, Suite 450, Charlotte, North Carolina 28209</u>
Phone Number:	<u>(213) 683-0088</u>	<u>(917) 509-5092</u>
E-Mail:	<u>lmullarkey-williams@gibsontrans.com</u>	<u>mstroyman@blackridgeventures.com</u>

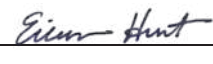
Approved by:	x <u></u> <small>Consultant's Representative</small>	<u>8/5/22</u> <small>Date</small>	x <u></u> <small>LADOT Representative</small>	<u>8/9/22</u> <small>**Date</small>
Adjacent Municipality:	_____	Approved by:	_____	_____
		<small>(if applicable)</small>	<small>Representative</small>	<small>Date</small>

**MOUs are generally valid for two years after signing. If after two years a transportation assessment has not been submitted to LADOT, the developer's representative shall check with the appropriate LADOT office to determine if the terms of this MOU are still valid or if a new MOU is needed.

Attachment C.1: Access Assessment Criteria



Access Assessment Criteria

This Criteria acknowledges that the Transportation Assessment for the following Project will be prepared in accordance with the latest version of LADOT’s Transportation Assessment Guidelines:

I. PROJECT INFORMATION

Project Name: 1200 Vine Project

Project Address: 1200, 1204, 1214, 1218 N Vine St, 6245, 6247 W Lexington Ave, Los Angeles, CA 90038

Project Description: The Project proposes 153 multi-family residential uses, including 18 affordable units, and 7,000 sf of commercial uses.

LADOT Project Case Number: CEN22-53727

II. PEDESTRIAN/ PERSON TRIP GENERATION

Source of Pedestrian/Person Trip Generation Rate(s)? IVMT Calculator ITE 10th Edition Other:

	Land Use	Size/Unit	Daily Person Trips
Proposed	To be provided.		
	<i>Total new trips:h</i>		

Pedestrian/Person trip generation table including a description of the proposed land uses, trip credits, person trip assumptions, comparison studies used for reference, etc. attached? Yes No

III. PEDESTRIAN ATTRACTORS INVENTORY

Attach Pedestrian Map for the area (1,320 foot radius from edge of the project site) depicting:

- site pedestrian entrance(s)
- Existing or proposed passenger loading zones
- pedestrian generation/distribution values
 - Geographic Distribution: N 25 % S 25 % E 25 % W 25 %h
- transit boarding and alighting of transit stops (should include Metro rail stations; Metro, DASH, and

other municipal bus stops)

- Key pedestrian destinations with hours of operation:
 - schools (school times)
 - government offices with a public counter or meeting room
 - senior citizen centers
 - recreation centers or playgrounds
 - public libraries
 - medical centers or clinics
 - child care facilities
 - post offices
 - places of worship
 - grocery stores
 - other facilities that attract pedestrian trips
- pedestrian walking routes to key destinations from project site

Note: Pedestrian Count Summary, Bicycle Count Summary, Manual Traffic Count Summary will need to be attached to the Transportation Assessment

IV. FACILITIES INVENTORY

Is a High Injury Network street located within 1,320 foot radius from the edge of the project site? Yes No

If yes, list streets and include distance from the project:

Vine St	at <u>0</u> (feet)
Santa Monica Blvd	at <u>682</u> (feet)
Cahuenga Blvd N of Fountain Ave	at <u>824</u> (feet)
_____	at _____ (feet)

Attach Radius Map for the area (1,320 foot radius from edge of the project site) depicting the following existing and proposed facilities:

- transit stops
- bike facilities
- traffic control devices for controlled crossings
- uncontrolled crosswalks
- location of any missing, damaged or substandard sidewalks

For a reference of planned facilities, see the [Transportation Assessment Support Map](#)

Crossing Distances

Does the project property have frontage along an arterial street (designated as either an Avenue or Boulevard?)

Yes No

If yes, provide the distance between the crossing control devices (e.g. signalized crosswalk, or controlled mid-block crossing) along any arterial within 1,320 feet of the property.

_____ (feet) at See Table 4	_____ (feet) at _____
_____ (feet) at _____	_____ (feet) at _____
_____ (feet) at _____	_____ (feet) at _____
_____ (feet) at _____	_____ (feet) at _____
_____ (feet) at _____	_____ (feet) at _____
_____ (feet) at _____	_____ (feet) at _____

V. Project Construction

Will the project require any construction activity within the city right-of-way? Yes No

If yes, will the project require temporary closure of any of the following city facilities?

- sidewalk
- bike lane
- parking lane
- travel lane
- bus stop
- bicycle parking (racks or corrals)
- bike share or other micro-mobility station
- car share station
- parklet
- other: _____

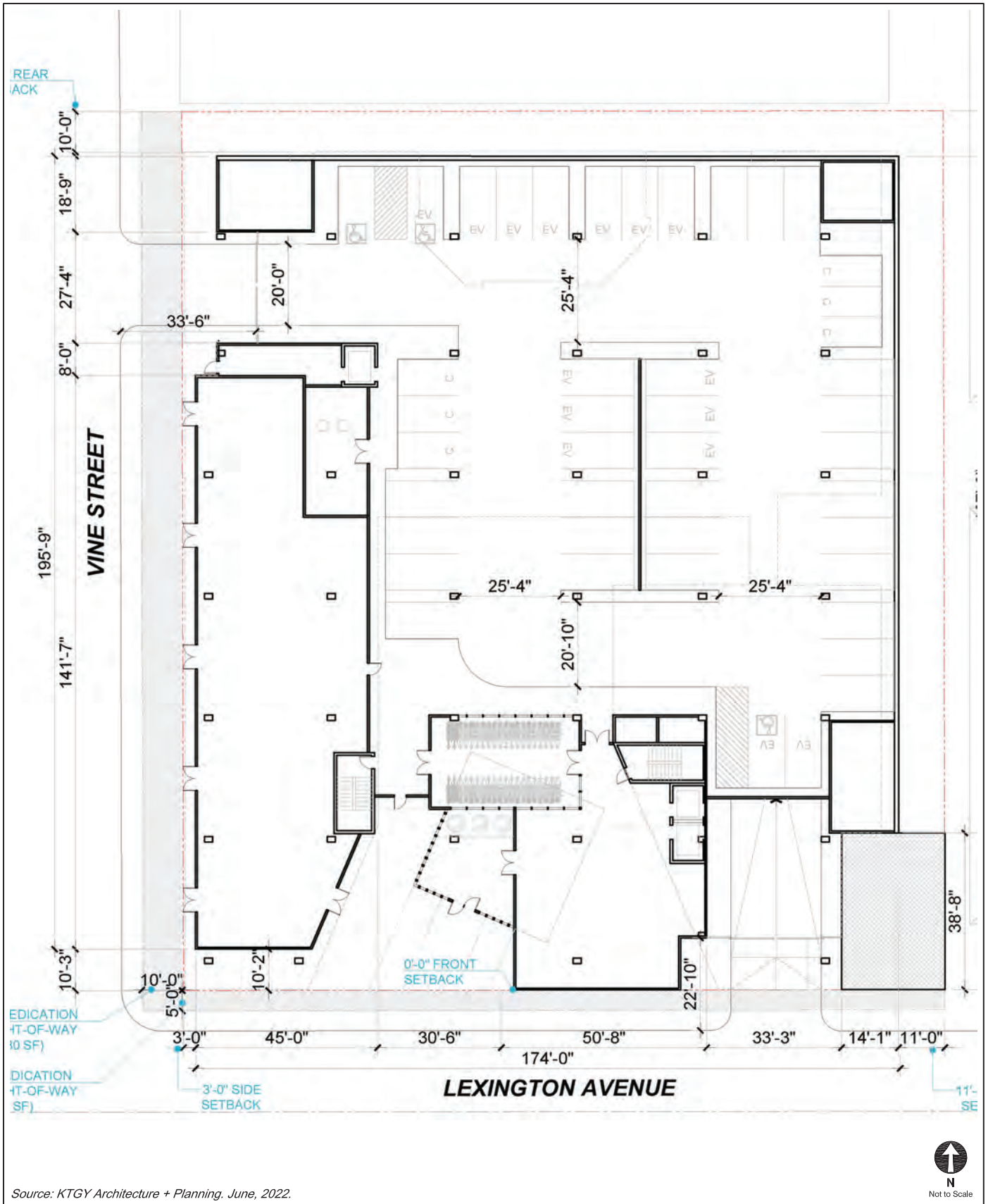

Source: KTG Architecture + Planning, June, 2022.

PROJECT SITE PLAN

FIGURE
1



LEGEND

 Project Site



PROJECT SITE LOCATION

FIGURE
2



LEGEND

- Project Site
- Project Driveway
- # Analyzed Intersection



STUDY AREA AND ANALYZED INTERSECTIONS

**FIGURE
3**

**TABLE 1
1200 VINE STREET TRIP GENERATION ESTIMATES**

Land Use	ITE Land Use	Rate or Size	Morning Peak Hour			Afternoon Peak Hour		
			In	Out	Total	In	Out	Total
TRIP GENERATION RATES [a]								
Multi-Family Housing (Mid-Rise)	221	per du	23%	77%	0.37	61%	39%	0.39
Affordable Housing	[b]	per du	37%	63%	0.49	56%	44%	0.35
High-Turnover (Sit-Down) Restaurant	932	per 1,000 sf	55%	45%	9.57	61%	39%	9.05
TRIP GENERATION ESTIMATES								
<u>Proposed Project</u>								
Multi-Family Housing (Mid-Rise) <i>Transit/Walk-In Reduction - 10% [c]</i>	221	135 du	12 (1)	38 (4)	50 (5)	32 (3)	21 (2)	53 (5)
Affordable Housing	[b]	18 du	3	6	9	3	3	6
Restaurant <i>Internal Capture Reduction - 10% [d]</i> <i>Transit/Walk-In Reduction - 10% [c]</i> <i>Pass-By Trip Reduction - 20% [e]</i>	932	7,000 sf	37 (4) (3) (6)	30 (3) (3) (5)	67 (7) (6) (11)	38 (4) (3) (6)	25 (3) (2) (4)	63 (7) (5) (10)
TOTAL NEW PROJECT TRIPS			38	59	97	57	38	95

Notes:

du = dwelling unit; sf = square feet

[a] Trip generation rates are for General Urban/Suburban areas from *Trip Generation Manual, 11th Edition* (Institute of Transportation Engineers, 2021), unless otherwise noted.

[b] Per LADOT's *Transportation Assessment Guidelines*, residential or mixed-use developments inside a Transit Priority Area (TPA) which include Affordable Housing Units are eligible to use a City-specific trip generation rate based on vehicle trip count data collected at affordable housing sites in the City of Los Angeles in 2016.

[c] Per LADOT's *Transportation Assessment Guidelines*, the Project Site is located within 0.25 miles from bus stops that serve Metro Local and LADOT DASH lines, thus a 10% transit reduction was applied to account for transit usage and walking visitor arrivals from the surrounding neighborhoods and adjacent commercial developments.

[d] Internal capture reductions account for person trips made between distinct land uses within a mixed-use development (i.e., residents visiting the commercial uses).

[e] Per Attachment H of LADOT's *Transportation Assessment Guidelines*, pass-by reductions were taken into account for Project trips made as an intermediate stop on the way from an origin to a primary trip destination without route diversion.

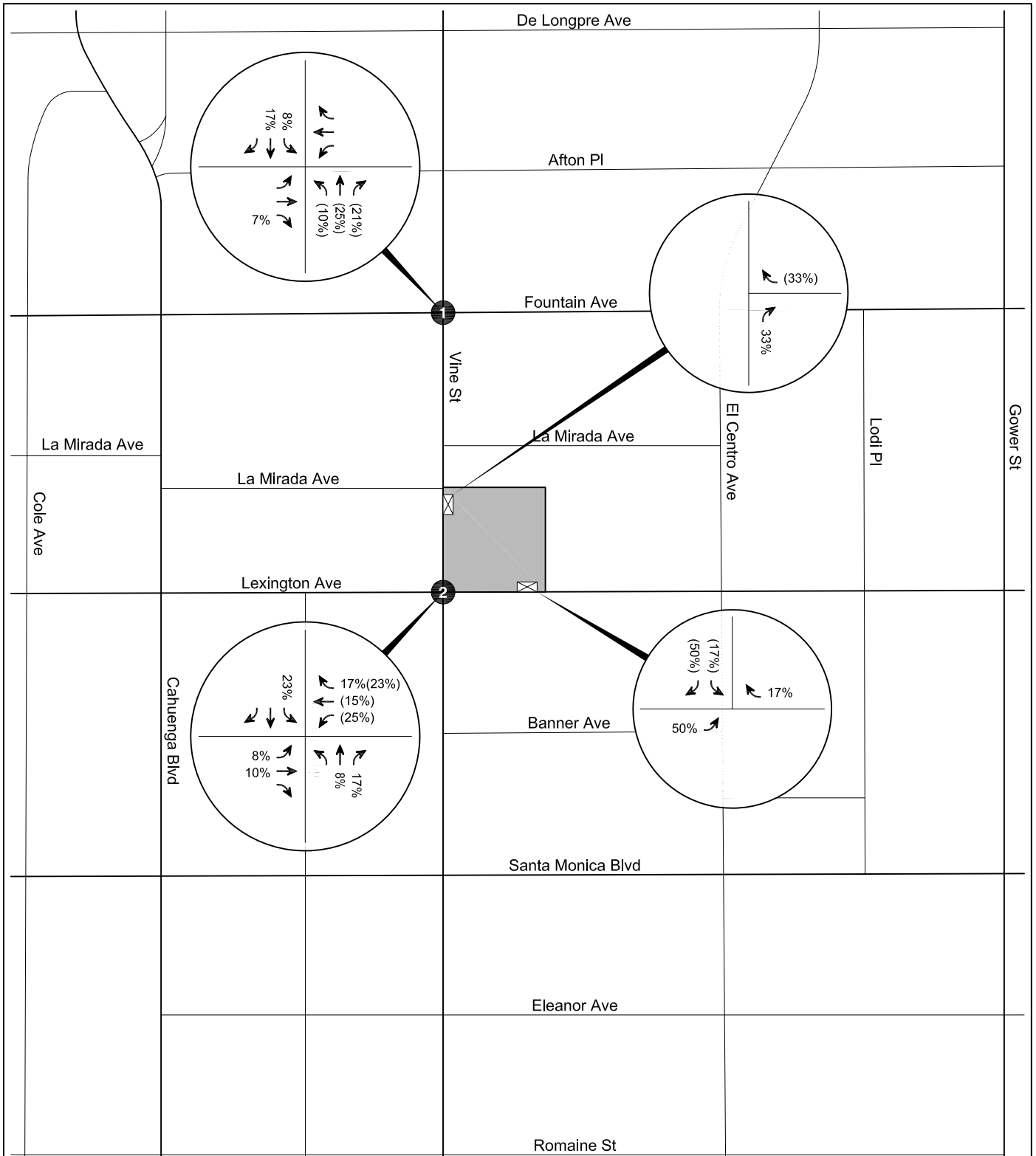

LEGEND

- Project Site
- # Analyzed Intersection
- Project Driveway
- %(%) Inbound(Outbound) Trip Percentage



**PROJECT TRIP DISTRIBUTION
RESIDENTIAL**

**FIGURE
4A**

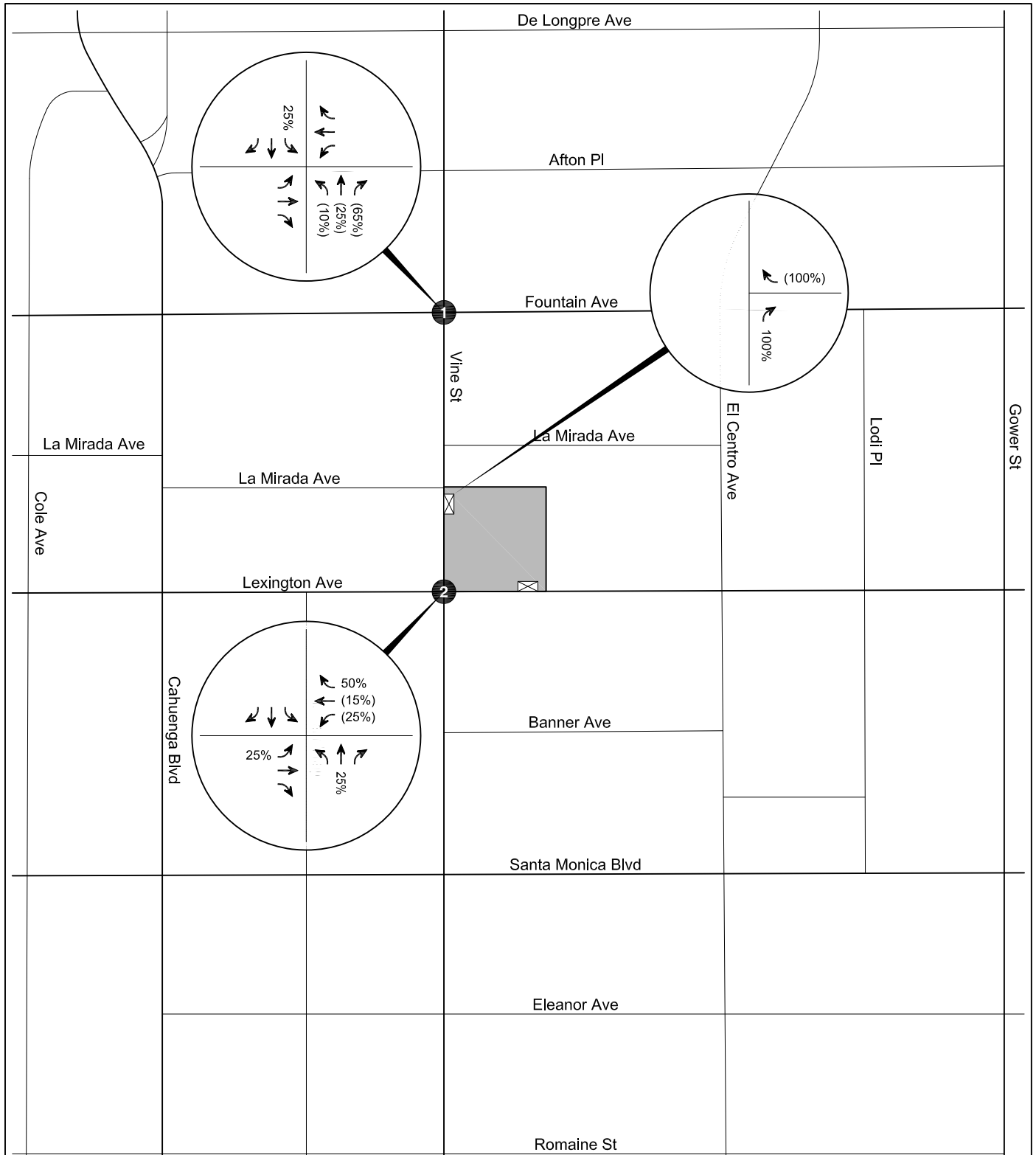

LEGEND

- Project Site
- # Analyzed Intersection
- Project Driveway
- %(%) Inbound(Outbound) Trip Percentage



**PROJECT TRIP DISTRIBUTION
COMMERCIAL**

**FIGURE
4B**

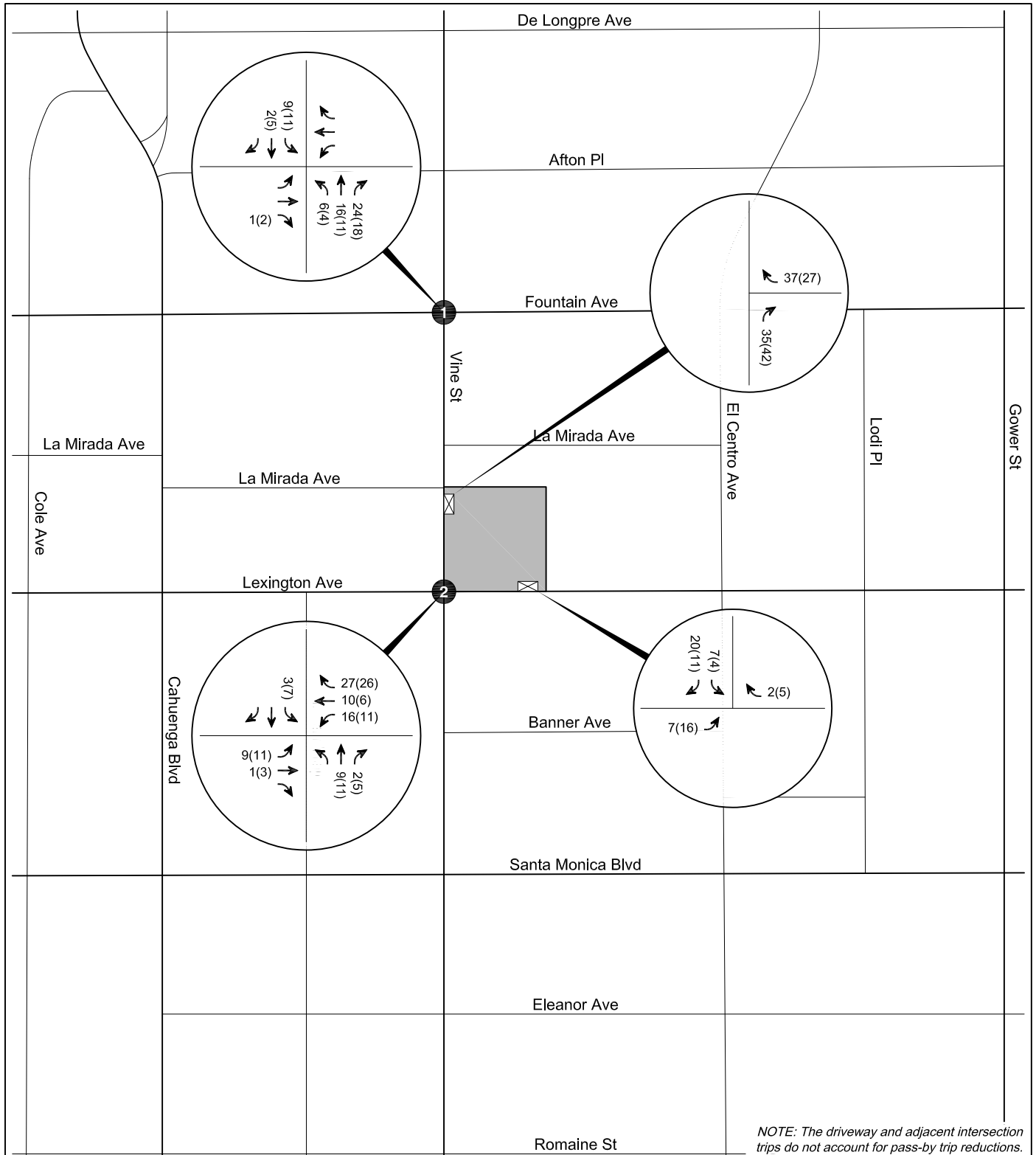

NOTE: The driveway and adjacent intersection trips do not account for pass-by trip reductions.

LEGEND

- Project Site
- Analyzed Intersection
- Project Driveway
- #(##) AM(PM) Peak Hour Traffic Volumes



**PROJECT-ONLY
PEAK HOUR TRAFFIC VOLUMES**

**FIGURE
5**

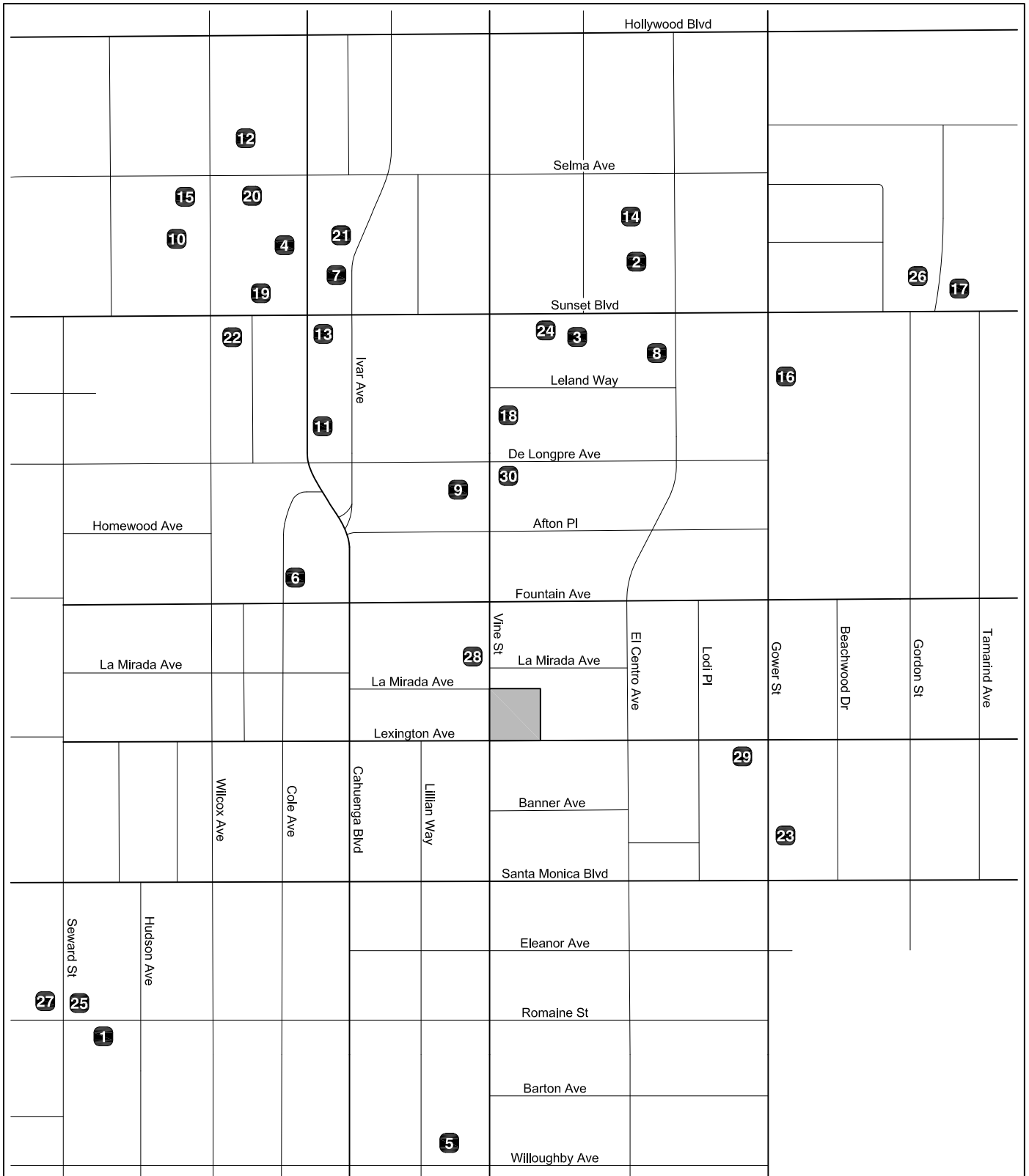

LEGEND

- Project Site
- # Related Project



LOCATIONS OF RELATED PROJECTS

FIGURE
6

**TABLE 2
1200 VINE RELATED PROJECTS**

No.	Project	Address	Use	Trip Generation [a]						
				Daily	Morning Peak Hour			Afternoon Peak Hour		
					In	Out	Total	In	Out	Total
1.	Seward St Office	956 N Seward St	126,980 sf office	1,240	165	21	186	29	151	180
2.	Palladium Residences	6201 W Sunset Bl	731 apartment units, including 37 affordable units, and 24,000 sf commercial	4,913	128	228	356	234	160	403
3. [b]	6250 Sunset (Nickelodeon)	6250 W Sunset Bl	200 apartment units and 4,700 sf retail	1,473	52	80	132	71	50	121
4.	Cahuenga Boulevard Hotel	1525 N Cahuenga Bl	64 hotel rooms, 3,300 sf restaurant, 1,200 sf guest lounge, and 700 sf rooftop restaurant	469	10	12	22	20	14	34
5. [b]	Mixed-Use	901 N Vine St	70 apartment units and 3,000 sf commercial	(32)	4	26	30	(5)	1	(4)
6. [b]	Mixed-Use	1310 N Cole Ave	369 apartment units, including 12 live-work and 20 affordable housing units, and 2,570 sf office	2,226	20	139	159	139	58	197
7.	Ivar Gardens Hotel	6409 W Sunset Bl	275 hotel rooms and 1,900 sf retail	1,285	51	26	77	53	60	113
8. [b]	6200 W Sunset Boulevard	6200 W Sunset Bl	270 apartment units, 8,070 sf retail, 2,300 sf pharmacy, and 1,750 sf quality restaurant	1,778	26	97	123	100	35	135
9. [b]	Academy Square	1341 Vine St	200 apartment units and 301,854 sf restaurant/office	6,218	330	164	494	152	220	372
10. [b]	Thompson Hotel	1541 N Wilcox Ave	200 hotel rooms, 5,125 sf ground floor restaurant and 4,105 sf rooftop restaurant/bar/lounge	2,058	76	57	133	82	75	157
11. [b]	Godfrey Hotel	1400 N Cahuenga Bl	220 hotel rooms, 2,723 sf restaurant, and 1,440 sf bar	1,875	55	47	102	78	60	138
12.	Selma-Wilcox hotel	6421 W Selma Ave	114 hotel rooms and 1,993 sf restaurant	1,227	43	27	70	56	44	100
13.	6400 Sunset Mixed-Use	6400 W Sunset Bl	200 apartment units and 7,000 sf restaurant	11	14	77	91	57	(6)	51
14.	Modera Argyle	1546 N Argyle Ave	276 apartment units, including 13 affordable housing units, 15,000 sf restaurant, and 9,000 sf retail	2,013	43	127	170	128	51	179
15.	Citizen News	1545 N Wilcox Ave	16,100 sf flexible event space and 14,800 sf restaurant	2,341	36	50	86	128	47	175

Notes:

[a] Related project information provided by the Los Angeles Department of Transportation and Los Angeles Department of City Planning in June 2022 and recent traffic studies prepared in the area. This list includes known development projects within one-half mile (2,460 foot) radius of the Project Site.

[b] Although construction of the related project may be partially complete/entirely complete, the project was not fully occupied at the time when traffic counts were conducted. Therefore, the related project was considered and listed to provide a more conservative analysis.

**TABLE 2
1200 VINE RELATED PROJECTS (CONT.)**

No.	Project	Address	Use	Trip Generation [a]						
				Daily	Morning Peak Hour			Afternoon Peak Hour		
					In	Out	Total	In	Out	Total
16.	Sunset Gower Studios	1438 N Gower St	828,339 sf office, 205,202 sf sound stage, 65,319 sf production support, and 6,516 sf restaurant	4,108	424	67	491	77	410	487
17. [b]	Sunset and Gordon Mixed-Use	5939 W Sunset Bl	299 apartment units, including 15 affordable housing units, 38,440 sf office, 3,700 sf restaurant, and 3,970 sf retail	3,731	152	191	343	182	152	334
18.	1400 Vine	1400 Vine St	198 apartment units, including 21 affordable housing units, and 16,000 sf restaurant	1,446	70	93	163	97	56	153
19.	6445 Sunset	6445 Sunset Bl	175 hotel rooms and 12,500 sf restaurant	1,409	77	58	135	80	61	141
20.	Wilcox & Selma Residential	6422 W Selma Ave	40 apartment units and 5 affordable housing units	126	(3)	10	7	9	(1)	8
21.	Artisan Hollywood	1520 N Cahuenga Bl	270 apartment units, including 27 affordable housing units and 6,805 sf restaurant	1,143	34	75	109	82	40	122
22.	Sunset + Wilcox Mixed-Use	6450 W Sunset Bl	431,032 sf office, and 12,386 sf restaurant	2,836	311	50	361	93	319	412
23.	Residential with Affordable Housing	1125 N Gower St	155 apartment units and 14 affordable housing units	667	13	35	48	32	21	53
24.	Sunset Vine 2	6266 W Sunset Bl	150 apartment units and 13,130 sf restaurant	603	11	35	46	33	22	55
25.	1000 Seward	1000 N Seward St	136,200 sf office, 12,200 sf restaurant, and 2,200 sf retail	1,669	147	48	195	58	135	193
26.	6007 Sunset Mixed-Use	6007 W Sunset Bl	110 apartment units and 14,555 sf retail	904	15	25	40	30	29	59
27. [b]	Hollywood Center Studios Office	6601 W Romaine St	106,125 sf office	808	88	4	92	12	39	51
28.	1235 Vine St	1235 Vine St	109,190 sf office and 7,960 sf restaurant	696	96	19	116	19	91	108
29.	Hollywood Production Center	1149 N Gower St	169 apartment units	735	6	23	29	23	12	35
30.	Onni Group Mixed-Use Development	1360 N Vine St	463,521 sf office, 11,914 sf restaurant and 8,998 sf additional restaurant	3,533	278	40	318	135	337	472

Notes:

[a] Related project information provided by the Los Angeles Department of Transportation and Los Angeles Department of City Planning in June 2022 and recent traffic studies prepared in the area. This list includes known development projects within one-half mile (2,460 foot) radius of the Project Site.

[b] Although construction of the related project may be partially complete/entirely complete, the project was not fully occupied at the time when traffic counts were conducted. Therefore, the related project was considered and listed to provide a more conservative analysis.

**TABLE 3
FREEWAY OFF-RAMP SCREENING PROCESS**

Freeway Off-Ramp	Peak Hour	Project Traffic	Meets Screening Criteria? [a]
US-101 Southbound [b]			
Off-ramp to Vine Steet	AM	4	NO
	PM	6	NO
US-101 Northbound [c]			
Off-ramp to Santa Monica Boulevard	AM	4	NO
	PM	6	NO

Notes:

[a] Based on *Interim Guidance for Freeway Safety Analysis* (LADOT, 2020), a transportation assessment for a development project must include analysis of any freeway off-ramp where a project adds 25 or more peak hour trips.

[b] 10% of incoming trips were assumed to travel Southbound on the US-101 to the Project Site via an off-ramp to Vine Street.

[c] 10% of incoming trips were assumed to travel Northbound on the US-101 to the Project Site via an off-ramp to Santa Monica Boulevard.

TABLE 4
1200 VINE STREET CROSSING DISTANCE INVENTORY
DISTANCE BETWEEN EXISTING PEDESTRIAN CROSSINGS
WITHIN VICINITY OF PROJECT SITE

Street Segment	Distance (ft)	From	To
Vine St	647	De Longpre Ave	Fountain Ave
	600	Fountain Ave	Lexington Ave
	602	Lexington Ave	Santa Monica Blvd
	603	Santa Monica Blvd	Romaine St
Wilcox Ave	662	De Longpre Ave	Fountain Ave
	1,237	Fountain Ave	Santa Monica Blvd
Cole Ave	623	De Longpre Ave	Fountain Ave
	1,247	Fountain Ave	Santa Monica Blvd
	601	Santa Monica Blvd	Romaine St
Cahuenga Blvd	655	De Longpre Ave	Fountain Ave
	1,247	Fountain Ave	Santa Monica Blvd
	698	Santa Monica Blvd	Romaine St
Santa Monica Blvd	608	Vine St	El Centro Ave
	620	El Centro Ave	Gower St
	610	Vine St	Cahuenga Blvd
	257	Cahuenga Blvd	Cole Ave
Gower St	605	Fountain Ave	Lexington Ave
	615	Lexington Ave	Santa Monica Blvd

CITY OF LOS ANGELES VMT CALCULATOR Version 1.3



Project Screening Criteria: Is this project required to conduct a vehicle miles traveled analysis?

Project Information

Project:

Scenario:

Address:

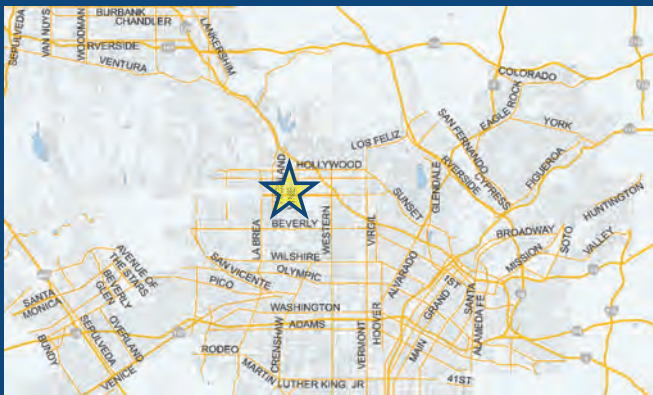

Is the project replacing an existing number of residential units with a smaller number of residential units AND is located within one-half mile of a fixed-rail or fixed-guideway transit station?

Yes No

Existing Land Use

Land Use Type	Value	Unit
Retail General Retail	0	ksf

[Click here to add a single custom land use type \(will be included in the above list\)](#)

Proposed Project Land Use

Land Use Type	Value	Unit
Housing Multi-Family	135	DU
Housing Multi-Family	135	
Retail High-Turnover Sit-Down Restaurant	7	
Housing Affordable Housing - Family	18	

[Click here to add a single custom land use type \(will be included in the above list\)](#)

Project Screening Summary

Existing Land Use	Proposed Project
0 Daily Vehicle Trips	1,025 Daily Vehicle Trips
0 Daily VMT	6,092 Daily VMT
Tier 1 Screening Criteria	
Project will have less residential units compared to existing residential units & is within one-half mile of a fixed-rail station. <input type="checkbox"/>	
Tier 2 Screening Criteria	
The net increase in daily trips < 250 trips	1,025 Net Daily Trips
The net increase in daily VMT ≤ 0	6,092 Net Daily VMT
The proposed project consists of only retail land uses ≤ 50,000 square feet total.	7,000 ksf
The proposed project is required to perform VMT analysis.	



VMT Calculator User Agreement

The Los Angeles Department of Transportation (LADOT), in partnership with the Department of City Planning and Fehr & Peers, has developed the City of Los Angeles Vehicle Miles Traveled (VMT) Calculator to estimate project-specific daily household VMT per capita and daily work VMT per employee for land use development projects. This application, the VMT Calculator, has been provided to You, the User, to assess vehicle miles traveled (VMT) outcomes of land use projects within the City of Los Angeles. The term “City” as used below shall refer to the City of Los Angeles. The terms “City” and “Fehr & Peers” as used below shall include their respective affiliates, subconsultants, employees, and representatives.

The City is pleased to be able to provide this information to the public. The City believes that the public is most effectively served when they are provided access to the technical tools that inform the public review process of private and public land use investments. However, in using the VMT Calculator, You agree to be bound by this VMT Calculator User Agreement (this Agreement).

VMT Calculator Application for the City of Los Angeles. The City’s consultant calibrated the VMT Calculator’s parameters in 2018 to estimate travel patterns of locations in the City, and validated those outcomes against empirical data. However, this calibration process is limited to locations within the City, and practitioners applying the VMT Calculator outside of the City boundaries should not apply these estimates without further calibration and validation of travel patterns to verify the VMT Calculator’s accuracy in estimating VMT in such other locations.

Limited License to Use. This Agreement gives You a limited, non-transferrable, non-assignable, and non-exclusive license to use and execute a copy of the VMT Calculator on a computer system owned, leased or otherwise controlled by You in Your own facilities, as set out below, provided You do not use the VMT Calculator in an unauthorized manner, and that You do not republish, copy, distribute, reverse-engineer, modify, decompile, disassemble, transfer, or sell any part of the VMT Calculator, and provided that You know and follow the terms of this Agreement. Your failure to follow the terms of this Agreement shall automatically terminate this license and Your right to use the VMT Calculator.

Ownership. You understand and acknowledge that the City owns the VMT Calculator, and shall continue to own it through Your use of it, and that no transfer of ownership of any kind is intended in allowing You to use the VMT Calculator.

Warranty Disclaimer. In spite of the efforts of the City and Fehr & Peers, some information on the VMT Calculator may not be accurate. The VMT Calculator, OUTPUTS AND ASSOCIATED DATA ARE PROVIDED “as is” WITHOUT WARRANTY OF ANY KIND, whether expressed, implied, statutory, or otherwise including but not limited to, the implied warranties of merchantability and fitness for a particular purpose.

Limitation of Liability. It is understood that the VMT Calculator is provided without charge. Neither the City nor Fehr & Peers can be responsible or liable for any information derived from its use, or for any delays, inaccuracies, incompleteness, errors or omissions arising out of your use of the VMT Calculator or with respect to the material contained in the VMT Calculator. You understand and agree that Your sole remedy against the City or Fehr & Peers for loss or damage caused by any defect or failure of the

VMT Calculator, regardless of the form of action, whether in contract, tort, including negligence, strict liability or otherwise, shall be the repair or replacement of the VMT Calculator to the extent feasible as determined solely by the City. In no event shall the City or Fehr & Peers be responsible to You or anyone else for, or have liability for any special, indirect, incidental or consequential damages (including, without limitation, damages for loss of business profits or changes to businesses costs) or lost data or downtime, however caused, and on any theory of liability from the use of, or the inability to use, the VMT Calculator, whether the data, and/or formulas contained in the VMT Calculator are provided by the City or Fehr & Peers, or another third party, even if the City or Fehr & Peers have been advised of the possibility of such damages.

This Agreement and License shall be governed by the laws of the State of California without regard to their conflicts of law provisions, and shall be effective as of the date set forth below and, unless terminated in accordance with the above or extended by written amendment to this Agreement, shall terminate on the earlier of the date that You are not making use of the VMT Calculator or one year after the beginning of Your use of the VMT Calculator.

By using the VMT Calculator, You hereby waive and release all claims, responsibilities, liabilities, actions, damages, costs, and losses, known and unknown, against the City and Fehr & Peers for Your use of the VMT Calculator.

Before making decisions using the information provided in this application, contact City LADOT staff to confirm the validity of the data provided.

Print and sign below, and submit to LADOT along with the transportation assessment Memorandum of Understanding (MOU).

You, the User	
By:	<u><i>Lauren Mullarkey-Williams</i></u>
Print Name:	<u>Lauren Mullarkey-Williams</u>
Title:	<u>Associate</u>
Company:	<u>Gibson Transportation Consulting, Inc.</u>
Address:	<u>555 W. 5th Street, Suite 3375, Los Angeles, CA 90013</u>
Phone:	<u>(213) 683-0088</u>
Email Address:	<u>lmullarkey-williams@gibsontrans.com</u>
Date:	<u>8/5/22</u>

Attachment B
Traffic Count Data

National Data & Surveying Services

Intersection Turning Movement Count

Location: Vine St & Fountain Ave
 City: Hollywood
 Control: Signalized

Project ID: 18-05272-056
 Date: 5/16/2018

Total

NS/EW Streets:	Vine St				Vine St				Fountain Ave				Fountain Ave				TOTAL
	NORTHBOUND				SOUTHBOUND				EASTBOUND				WESTBOUND				
AM	1	2	0	0	1	2	0	0	1	1	0	0	1	1	0	0	TOTAL
	NL	NT	NR	NU	SL	ST	SR	SU	EL	ET	ER	EU	WL	WT	WR	WU	
7:00 AM	5	152	5	0	4	257	12	0	7	15	4	0	11	69	6	0	547
7:15 AM	5	153	9	0	5	282	14	0	7	29	3	0	10	79	5	0	601
7:30 AM	13	135	6	0	6	324	15	0	16	45	5	0	12	81	10	0	668
7:45 AM	14	164	7	0	4	300	24	0	11	51	7	0	20	115	11	0	728
8:00 AM	8	178	10	0	10	293	18	0	9	41	3	0	16	89	5	0	680
8:15 AM	8	220	9	0	10	281	30	1	16	50	6	0	10	86	9	1	737
8:30 AM	11	211	6	0	5	322	24	0	9	40	8	0	21	103	9	0	769
8:45 AM	7	265	8	0	6	330	13	0	19	48	8	0	16	101	10	0	831
9:00 AM	15	267	11	0	6	307	26	0	21	66	12	0	19	76	12	0	838
9:15 AM	6	206	12	0	3	284	21	0	20	74	13	0	20	118	12	0	789
9:30 AM	6	224	9	0	6	259	14	0	20	46	4	0	20	130	10	0	748
9:45 AM	6	260	18	0	7	298	16	0	16	48	9	0	21	99	9	0	807
TOTAL VOLUMES :	NL	NT	NR	NU	SL	ST	SR	SU	EL	ET	ER	EU	WL	WT	WR	WU	TOTAL
APPROACH %'s :	104	2435	110	0	72	3537	227	1	171	553	82	0	196	1146	108	1	8743
	3.93%	91.92%	4.15%	0.00%	1.88%	92.18%	5.92%	0.03%	21.22%	68.61%	10.17%	0.00%	13.51%	78.98%	7.44%	0.07%	
PEAK HR :	08:30 AM - 09:30 AM																TOTAL
PEAK HR VOL :	39	949	37	0	20	1243	84	0	69	228	41	0	76	398	43	0	3227
PEAK HR FACTOR :	0.650	0.889	0.771	0.000	0.833	0.942	0.808	0.000	0.821	0.770	0.788	0.000	0.905	0.843	0.896	0.000	0.963
	0.875				0.959				0.790				0.862				
PM	NORTHBOUND				SOUTHBOUND				EASTBOUND				WESTBOUND				TOTAL
	1	2	0	0	1	2	0	0	1	1	0	0	1	1	0	0	
	NL	NT	NR	NU	SL	ST	SR	SU	EL	ET	ER	EU	WL	WT	WR	WU	
4:00 PM	15	282	20	1	8	239	13	0	32	109	9	0	11	52	20	0	811
4:15 PM	12	319	13	0	5	277	11	0	21	104	16	0	17	60	14	0	869
4:30 PM	8	260	17	0	9	314	13	0	16	95	8	0	10	73	11	0	834
4:45 PM	12	251	16	0	14	267	11	0	14	110	10	0	20	71	8	0	804
5:00 PM	12	297	15	0	13	289	20	0	32	126	15	0	23	72	13	0	927
5:15 PM	15	290	10	0	6	264	21	0	21	119	19	0	19	75	13	0	872
5:30 PM	7	253	19	0	10	242	24	0	16	124	12	1	19	75	16	0	818
5:45 PM	13	260	23	0	8	292	23	0	30	105	11	0	16	68	18	0	867
6:00 PM	7	309	13	1	7	312	33	0	29	126	10	0	18	77	13	0	955
6:15 PM	27	273	17	0	12	280	25	0	30	123	9	0	24	86	13	0	919
6:30 PM	10	254	16	1	16	232	26	0	33	127	10	0	18	78	11	0	832
6:45 PM	13	295	10	0	14	241	18	0	28	128	14	0	18	85	13	0	877
TOTAL VOLUMES :	NL	NT	NR	NU	SL	ST	SR	SU	EL	ET	ER	EU	WL	WT	WR	WU	TOTAL
APPROACH %'s :	151	3343	189	3	122	3249	238	0	302	1396	143	1	213	872	163	0	10385
	4.10%	90.69%	5.13%	0.08%	3.38%	90.02%	6.59%	0.00%	16.40%	75.79%	7.76%	0.05%	17.07%	69.87%	13.06%	0.00%	
PEAK HR :	06:00 PM - 07:00 PM																TOTAL
PEAK HR VOL :	57	1131	56	2	49	1065	102	0	120	504	43	0	78	326	50	0	3583
PEAK HR FACTOR :	0.528	0.915	0.824	0.500	0.766	0.853	0.773	0.000	0.909	0.984	0.768	0.000	0.813	0.948	0.962	0.000	0.938
	0.944				0.864				0.981				0.923				

Vine St & Fountain Ave

Peak Hour Turning Movement Count

ID: 18-05272-056
City: Hollywood

Day: Wednesday
Date: 05/16/2018

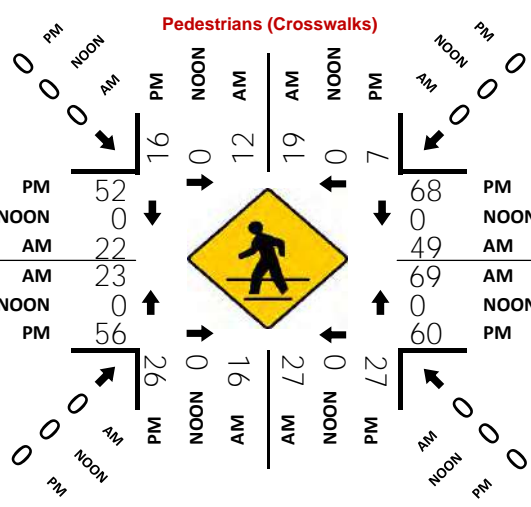
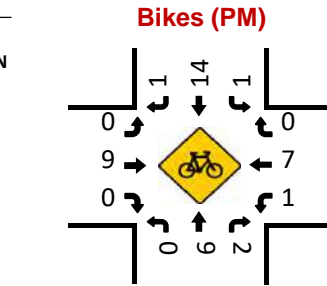
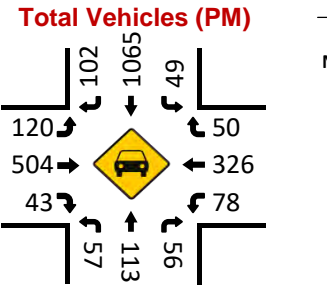
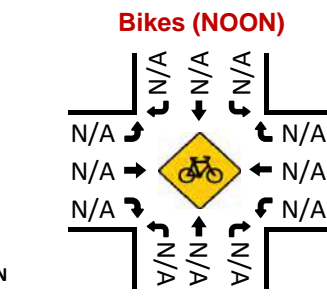
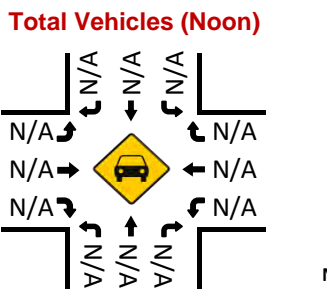
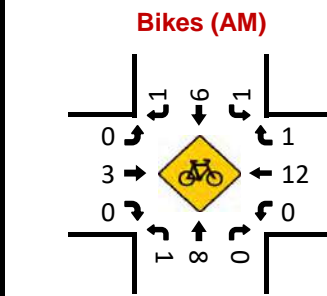
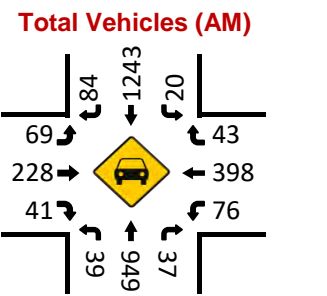
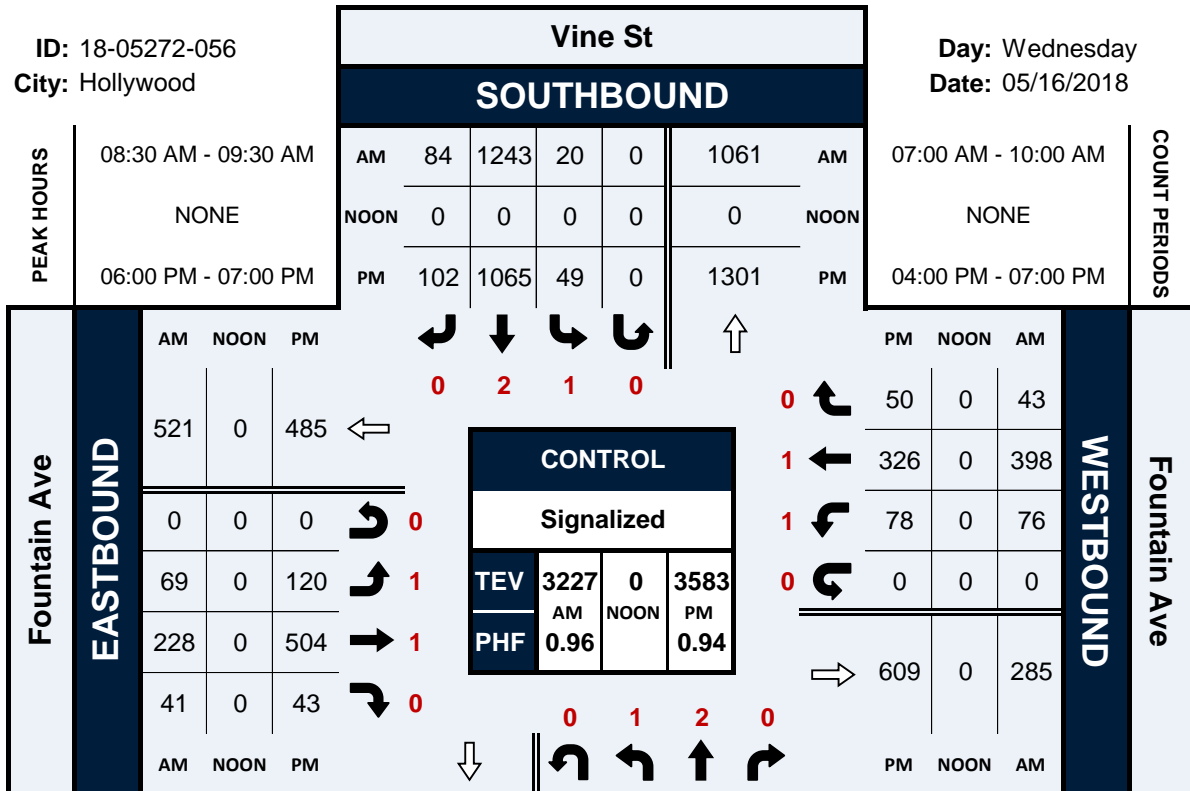

National Data & Surveying Services

Intersection Turning Movement Count

Location: Vine St & Lexington Ave
 City: Hollywood
 Control: Signalized

Project ID: 18-05272-058
 Date: 5/16/2018

Total

NS/EW Streets:	Vine St				Vine St				Lexington Ave				Lexington Ave					
AM	NORTHBOUND				SOUTHBOUND				EASTBOUND				WESTBOUND					
	1	2	0	0	1	2	0	0	0	1	0	0	0	1	0	0		
	NL	NT	NR	NU	SL	ST	SR	SU	EL	ET	ER	EU	WL	WT	WR	WU	TOTAL	
	7:00 AM	3	166	2	0	2	282	5	0	2	6	2	0	2	4	6	0	482
	7:15 AM	3	149	3	1	1	283	9	0	3	2	3	0	10	15	6	0	488
	7:30 AM	11	156	4	0	4	327	9	0	1	8	7	0	10	20	9	0	566
	7:45 AM	6	193	4	1	3	298	12	0	1	5	8	0	13	24	6	0	574
	8:00 AM	9	208	8	0	10	297	20	0	3	6	14	0	14	16	8	0	613
	8:15 AM	15	246	3	0	3	279	15	0	1	10	11	0	11	24	6	0	624
	8:30 AM	3	214	1	0	6	315	7	0	6	11	10	0	5	13	3	0	594
8:45 AM	5	262	3	0	4	330	14	0	3	6	6	0	3	16	14	0	666	
9:00 AM	2	273	7	1	3	322	15	0	8	6	5	0	8	14	5	0	669	
9:15 AM	7	228	3	0	9	292	12	0	2	5	6	0	12	19	6	0	601	
9:30 AM	3	258	1	1	8	271	5	0	1	3	5	0	6	13	4	0	579	
9:45 AM	7	258	3	0	5	317	6	0	6	3	3	0	4	21	10	0	643	
TOTAL VOLUMES :	NL	NT	NR	NU	SL	ST	SR	SU	EL	ET	ER	EU	WL	WT	WR	WU	TOTAL	
APPROACH %'s :	74	2611	42	4	58	3613	129	0	37	71	80	0	98	199	83	0	7099	
	2.71%	95.61%	1.54%	0.15%	1.53%	95.08%	3.39%	0.00%	19.68%	37.77%	42.55%	0.00%	25.79%	52.37%	21.84%	0.00%		
PEAK HR :	08:15 AM - 09:15 AM																TOTAL	
PEAK HR VOL :	25	995	14	1	16	1246	51	0	18	33	32	0	27	67	28	0	2553	
PEAK HR FACTOR :	0.417	0.911	0.500	0.250	0.667	0.944	0.850	0.000	0.563	0.750	0.727	0.000	0.614	0.698	0.500	0.000	0.954	
	0.914				0.943				0.769				0.744					
PM	NORTHBOUND				SOUTHBOUND				EASTBOUND				WESTBOUND					
	1	2	0	0	1	2	0	0	0	1	0	0	0	1	0	0		
	NL	NT	NR	NU	SL	ST	SR	SU	EL	ET	ER	EU	WL	WT	WR	WU	TOTAL	
	4:00 PM	2	323	12	0	6	246	5	0	2	15	9	0	7	6	17	0	650
	4:15 PM	4	325	10	0	7	295	8	0	4	23	9	0	3	12	7	0	707
	4:30 PM	1	273	8	0	8	305	4	1	6	16	8	0	3	13	7	0	653
	4:45 PM	6	268	9	0	9	255	12	1	8	29	8	0	8	8	9	0	630
	5:00 PM	10	295	5	0	14	279	12	0	12	32	15	0	14	6	18	0	712
	5:15 PM	6	320	3	0	9	309	8	1	7	29	13	0	12	10	7	0	734
	5:30 PM	5	262	5	0	5	250	5	0	5	16	11	0	5	7	15	0	591
5:45 PM	7	286	10	0	7	298	11	1	9	26	19	0	5	6	6	0	691	
6:00 PM	2	290	12	0	12	305	8	0	13	26	11	0	4	11	9	0	703	
6:15 PM	3	286	6	1	2	307	5	0	9	44	9	0	6	16	21	0	715	
6:30 PM	5	288	8	0	5	263	4	0	9	24	6	0	5	11	15	0	643	
6:45 PM	6	303	7	0	12	254	10	0	9	14	12	0	10	3	11	0	651	
TOTAL VOLUMES :	NL	NT	NR	NU	SL	ST	SR	SU	EL	ET	ER	EU	WL	WT	WR	WU	TOTAL	
APPROACH %'s :	57	3519	95	1	96	3366	92	4	93	294	130	0	82	109	142	0	8080	
	1.55%	95.83%	2.59%	0.03%	2.70%	94.60%	2.59%	0.11%	17.99%	56.87%	25.15%	0.00%	24.62%	32.73%	42.64%	0.00%		
PEAK HR :	05:45 PM - 06:45 PM																TOTAL	
PEAK HR VOL :	17	1150	36	1	26	1173	28	1	40	120	45	0	20	44	51	0	2752	
PEAK HR FACTOR :	0.607	0.991	0.750	0.250	0.542	0.955	0.636	0.250	0.769	0.682	0.592	0.000	0.833	0.688	0.607	0.000	0.962	
	0.990				0.945				0.827				0.669					

Vine St & Lexington Ave

Peak Hour Turning Movement Count

ID: 18-05272-058
City: Hollywood

Day: Wednesday
Date: 05/16/2018

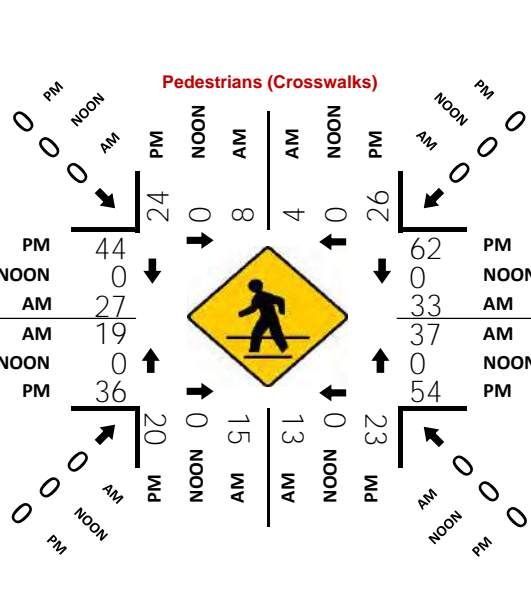
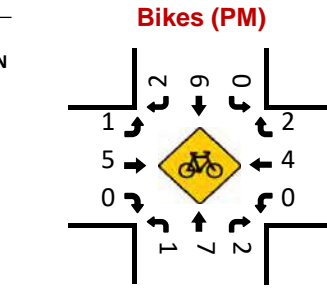
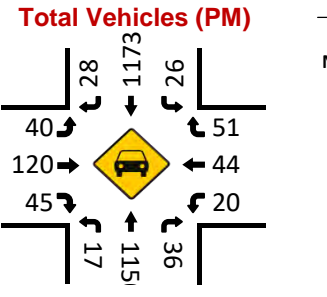
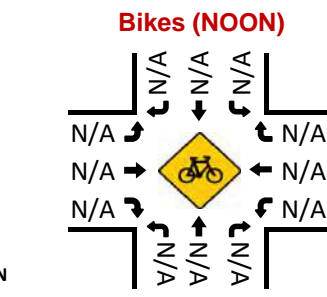
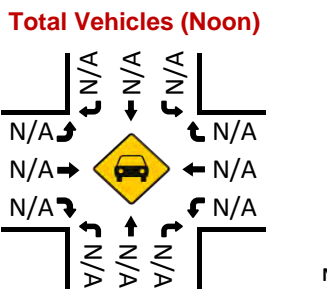
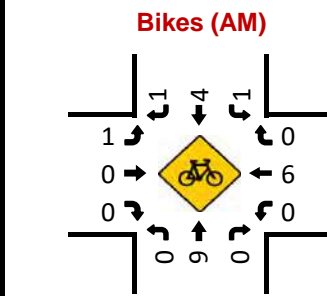
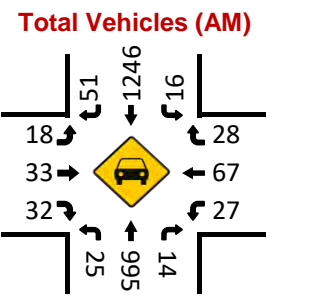
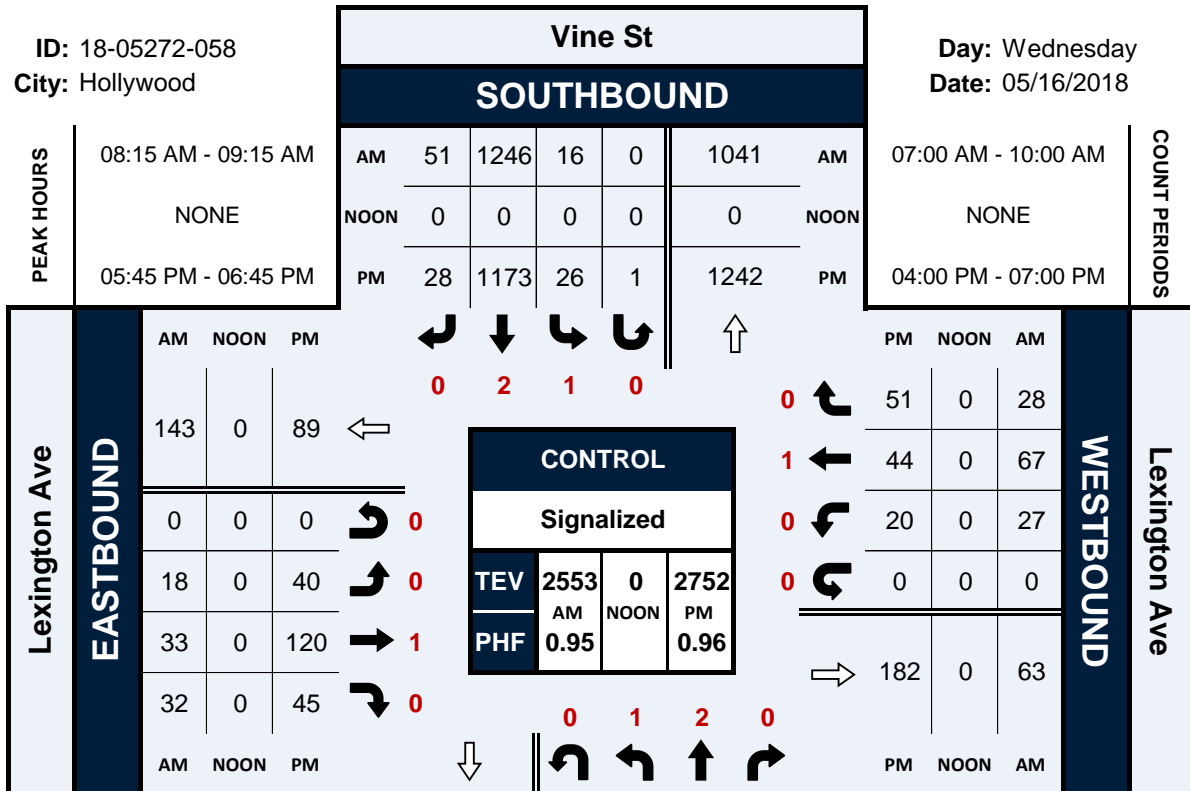

Attachment C

Plans, Policies, and Programs Consistency Worksheet



Attachment D: Plan, Policy, and Program Consistency Worksheet

Plans, Policies and Programs Consistency Worksheet

The worksheet provides a structured approach to evaluate the threshold T-1 question below, that asks whether a project conflicts with a program, plan, ordinance or policy addressing the circulation system. The intention of the worksheet is to streamline the project review by highlighting the most relevant plans, policies and programs when assessing potential impacts to the City's circulation system.

Threshold T-1: Would the project conflict with a program, plan, ordinance, or policy addressing the circulation system, including transit, roadways, bicycle, and pedestrian facilities?

This worksheet does not include an exhaustive list of City policies, and does not include community plans, specific plans, or any area-specific regulatory overlays. The Department of City Planning project planner will need to be consulted to determine if the project would obstruct the City from carrying out a policy or program in a community plan, specific plan, streetscape plan, or regulatory overlay that was adopted to support multimodal transportation options or public safety. LADOT staff should be consulted if a project would lead to a conflict with a mobility investment in the Public Right of Way (PROW) that is currently undergoing planning, design, or delivery. This worksheet must be completed for all projects that meet the Section I. Screening Criteria. For description of the relevant planning documents, **see Attachment D.1.**

For any response to the following questions that checks the box in **bold text** (i.e. **Yes** or **No**), further analysis is needed to demonstrate that the project does not conflict with a plan, policy, or program.

I. SCREENING CRITERIA FOR POLICY ANALYSIS

If the answer is 'yes' to any of the following questions, further analysis will be required:

Does the project require a discretionary action that requires the decision maker to find that the project would substantially conform to the purpose, intent and provisions of the General Plan?

Yes No

Is the project known to directly conflict with a transportation plan, policy, or program adopted to support multimodal transportation options or public safety?

Yes No

Is the project required to or proposing to make any voluntary modifications to the public right-of-way (i.e., dedications and/or improvements in the right-of-way, reconfigurations of curb line, etc.)?

Yes No

II. PLAN CONSISTENCY ANALYSIS

A. Mobility Plan 2035 PROW Classification Standards for Dedications and Improvements

These questions address potential conflict with:



Plan, Policy, and Program Consistency Worksheet

Mobility Plan 2035 Policy 2.1 – Adaptive Reuse of Streets. Design, plan, and operate streets to serve multiple purposes and provide flexibility in design to adapt to future demands.

Mobility Plan 2035 Policy 2.3 – Pedestrian Infrastructure. Recognize walking as a component of every trip, and ensure high quality pedestrian access in all site planning and public right-of-way modifications to provide a safe and comfortable walking environment.

Mobility Plan 2035 Policy 3.2 – People with Disabilities. Accommodate the needs of people with disabilities when modifying or installing infrastructure in the public right-of-way.

Mobility Plan 2035 Street Designations and Standard Roadway Dimensions

A.1 Does the project include additions or new construction along a street designated as a Boulevard I, and II, and/or Avenue I, II, or III on property zoned for R3 or less restrictive zone? Yes No

A.2 If **A.1 is yes**, is the project required to make additional dedications or improvements to the Public Right of Way as demonstrated by the street designation. Yes No N/A

A.3 If **A.2 is yes**, is the project making the dedications and improvements as necessary to meet the designated dimensions of the fronting street (Boulevard I, and II, or Avenue I, II, or III)? Yes No N/A

If the answer is to **A.1 or A.2 is NO, or to A.1, A.2 and A.3. is YES**, then the project does not conflict with the dedication and improvement requirements that are needed to comply with the Mobility Plan 2035 Street Designations and Standard Roadway Dimensions.

A.4 If the answer to **A.3. is NO**, is the project applicant asking to waive from the dedication standards? Yes No N/A

Lists any streets subject to dedications or voluntary dedications and include existing roadway and sidewalk widths, required roadway and sidewalk widths, and proposed roadway and sidewalk width or waivers.

Vine Lexington	Frontage 1 Existing PROW'/Curb' : Existing <u>68'/90'</u> Required <u>56'/86'</u> Proposed <u>68'/90'</u>
	Frontage 2 Existing PROW'/Curb' : Existing <u>40'/60'</u> Required <u>36'/60'</u> Proposed <u>40'/60'</u>
	Frontage 3 Existing PROW'/Curb' : Existing _____ Required _____ Proposed _____
	Frontage 4 Existing PROW'/Curb' : Existing _____ Required _____ Proposed _____

If the answer to **A.4 is NO**, the project is inconsistent with Mobility Plan 2035 street designations and must file for a waiver of street dedication and improvement.

If the answer to **A.4 is YES**, additional analysis is necessary to determine if the dedication and/or improvements are necessary to meet the City's mobility needs for the next 20 years. The following factors may contribute to determine if the dedication or improvement is necessary:

Is the project site along any of the following networks identified in the City's Mobility Plan?



Plan, Policy, and Program Consistency Worksheet

- Transit Enhanced Network
- Bicycle Enhanced Network
- Bicycle Lane Network
- Pedestrian Enhanced District
- Neighborhood Enhanced Network

To see the location of the above networks, see **Transportation Assessment Support Map**.¹

Is the project within the service area of Metro Bike Share, or is there demonstrated demand for micro-mobility services?

If the project dedications and improvements asking to be waived are necessary to meet the City's mobility needs, the project may be found to conflict with a plan that is adopted to protect the environment.

B. Mobility Plan 2035 PROW Policy Alignment with Project-Initiated Changes

B.1 Project-Initiated Changes to the PROW Dimensions

These questions address potential conflict with:

Mobility Plan 2035 Policy 2.1 – *Adaptive Reuse of Streets. Design, plan, and operate streets to serve multiple purposes and provide flexibility in design to adapt to future demands.*

Mobility Plan 2035 Policy 2.3 – *Pedestrian Infrastructure. Recognize walking as a component of every trip, and ensure high quality pedestrian access in all site planning and public right-of-way modifications to provide a safe and comfortable walking environment.*

Mobility Plan 2035 Policy 3.2 – *People with Disabilities. Accommodate the needs of people with disabilities when modifying or installing infrastructure in the public right-of-way.*

Mobility Plan 2035 Policy 2.10 – *Loading Areas. Facilitate the provision of adequate on and off-site street loading areas.*

Mobility Plan 2035 Street Designations and Standard Roadway Dimensions

B.1 Does the project propose, above and beyond any PROW changes needed to comply with Section 12.37 of the LAMC as discussed in Section II.A, physically modify the curb placement or turning radius and/or physically alter the sidewalk and parkways space that changes how people access a property?

Examples of developer-initiated physical changes to the public right-of-way include:

- widening the roadway,
- narrowing the sidewalk,
- adding space for vehicle turn outs or loading areas,
- removing bicycle lanes, bike share stations, or bicycle parking

¹ LADOT Transportation Assessment Support Map <https://arcg.is/fubbd>



Plan, Policy, and Program Consistency Worksheet

- modifying existing bus stop, transit shelter, or other street furniture
- paving, narrowing, shifting or removing an existing parkway or tree well

Yes No

B.2 Driveway Access

These questions address potential conflict with:

***Mobility Plan 2035 Policy 2.10 – Loading Areas.** Facilitate the provision of adequate on and off-site street loading areas.*

***Mobility Plan 2035 Program PL.1. Driveway Access.** Require driveway access to buildings from non-arterial streets or alleys (where feasible) in order to minimize interference with pedestrian access and vehicular movement.*

***Citywide Design Guidelines - Guideline 2:** Carefully incorporate vehicular access such that it does not degrade the pedestrian experience.*

Site Planning Best Practices:

- *Prioritize pedestrian access first and automobile access second. Orient parking and driveways toward the rear or side of buildings and away from the public right-of-way. On corner lots, parking should be oriented as far from the corner as possible.*
- *Minimize both the number of driveway entrances and overall driveway widths.*
- *Do not locate drop-off/pick-up areas between principal building entrances and the adjoining sidewalks.*
- *Orient vehicular access as far from street intersections as possible.*
- *Place drive-thru elements away from intersections and avoid placing them so that they create a barrier between the sidewalk and building entrance(s).*
- *Ensure that loading areas do not interfere with on-site pedestrian and vehicular circulation by separating loading areas and larger commercial vehicles from areas that are used for public parking and public entrances.*

B.2 Does the project add new driveways along a street designated as an Avenue or a Boulevard that conflict with LADOT’s Driveway Design Guidelines (See Sec. 321 in the Manual of Policies and Procedures) by any of the following:

- locating new driveways for residential properties on an Avenue or Boulevard, and access is otherwise possible using an alley or a collector/local street, or
- locating new driveways for industrial or commercial properties on an Avenue or Boulevard and access is possible along a collector/local street, or
- the total number of new driveways exceeds 1 driveway per every 200 feet² along on the Avenue or Boulevard frontage, or
- locating new driveways on an Avenue or Boulevard within 150 feet from the intersecting street, or
- locating new driveways on a collector or local street within 75 feet from the intersecting street, or

² for a project frontage that exceeds 400 feet along an Avenue or Boulevard, the incremental additional driveway above 2 is more than 1 driveway for every 400 additional feet.



Plan, Policy, and Program Consistency Worksheet

- locating new driveways near mid-block crosswalks, requiring relocation of the mid-block crosswalk

Yes No

If the answer to **B.1 and B.2 are both NO**, then the project would not conflict with a plan or policies that govern the PROW as a result of the project-initiated changes to the PROW.

Impact Analysis

If the answer to either **B.1 or B.2 are YES**, City plans and policies should be reviewed in light of the proposed physical changes to determine if the City would be obstructed from carrying out the plans and policies. The analysis should pay special consideration to substantial changes to the Public Right of Way that may either degrade existing facilities for people walking and bicycling (e.g., removing a bicycle lane), or preclude the City from completing complete street infrastructure as identified in the Mobility Plan 2035, especially if the physical changes are along streets that are on the High Injury Network (HIN). The analysis should also consider if the project is in a Transit Oriented Community (TOC) area, and would degrade or inhibit trips made by biking, walking and/ or transit ridership. The streets that need special consideration are those that are included on the following networks identified in the Mobility Plan 2035, or the HIN:

- Transit Enhanced Network
- Bicycle Enhanced Network
- Bicycle Lane Network
- Pedestrian Enhanced District
- Neighborhood Enhanced Network
- High Injury Network

To see the location of the above networks, see **Transportation Assessment Support Map**.³

Once the project is reviewed relevant to plans and policies, and existing facilities that may be impacted by the project, the analysis will need to answer the following two questions in concluding if there is an impact due to plan inconsistency.

B.2.1 Would the physical changes in the public right of way or new driveways that conflict with LADOT's Driveway Design Guidelines degrade the experience of vulnerable roadway users such as modify, remove, or otherwise negatively impact existing bicycle, transit, and/or pedestrian infrastructure?

Yes No N/A

B.2.2 Would the physical modifications or new driveways that conflict with LADOT's Driveway Design Guidelines preclude the City from advancing the safety of vulnerable roadway users?

Yes No N/A

If either of the answers to either **B.2.1 or B.2.2 are YES**, the project may conflict with the Mobility Plan 2035, and therefore conflict with a plan that is adopted to protect the

³ LADOT Transportation Assessment Support Map <https://arcg.is/fubbD>



Plan, Policy, and Program Consistency Worksheet

environment. If either of the answers to both **B.2.1. or B.2.2. are NO**, then the project would not be shown to conflict with plans or policies that govern the Public Right-of-Way.

C. Network Access

C. 1 Alley, Street and Stairway Access

These questions address potential conflict with:

Mobility Plan Policy 3.9 Increased Network Access: Discourage the vacation of public rights-of-way.

C.1.1 Does the project propose to vacate or otherwise restrict public access to a street, alley, or public stairway?

Yes No

C.1.2 If the answer to C.1.1 is Yes, will the project provide or maintain public access to people walking and biking on the street, alley or stairway?

Yes No N/A

C.2 New Cul-de-sacs

These questions address potential conflict with:

Mobility Plan 2035 Policy 3.10 Cul-de-sacs: Discourage the use of cul-de-sacs that do not provide access for active transportation options.

C.2.1 Does the project create a cul-de-sac or is the project located adjacent to an existing cul-de-sac?

Yes No

C.2.2 If yes, will the cul-de-sac maintain convenient and direct public access to people walking and biking to the adjoining street network?

Yes No N/A

If the answers to either C.1.2 or C.2.2 are YES, then the project would not conflict with a plan or policies that ensures access for all modes of travel. If the answer to either **C.1.2 or C.2.2 are NO**, the project may conflict with a plan or policies that governs multimodal access to a property. Further analysis must assess to the degree that pedestrians and bicyclists have sufficient public access to the transportation network.

D. Parking Supply and Transportation Demand Management

These questions address potential conflict with:

Mobility Plan 2035 Policy 3.8 – Bicycle Parking, Provide bicyclists with convenient, secure and well maintained bicycle parking facilities.

Mobility Plan 2035 Policy 4.8 – Transportation Demand Management Strategies. Encourage greater utilization of Transportation Demand Management Strategies to reduce dependence on single-occupancy vehicles.



Plan, Policy, and Program Consistency Worksheet

Mobility Plan 2035 Policy 4.13 – Parking and Land Use Management: Balance on-street and off-street parking supply with other transportation and land use objectives.

D.1 Would the project propose a supply of onsite parking that exceeds the baseline amount⁴ as required in the Los Angeles Municipal Code or a Specific plan, whichever requirement prevails?

Yes No

D.2 If the answer to D.1. is YES, would the project propose to actively manage the demand of parking by independently pricing the supply to all users (e.g. parking cash-out), or for residential properties, unbundle the supply from the lease or sale of residential units?

Yes No N/A

If the answer to **D.2. is NO** the project may conflict with parking management policies. Further analysis is needed to demonstrate how the supply of parking above city requirements will not result in additional (induced) drive-alone trips as compared to an alternative that provided no more parking than the baseline required by the LAMC or Specific Plan. If there is potential for the supply of parking to result in induced demand for drive-alone trips, the project should further explore transportation demand management (TDM) measures to further off-set the induced demands of driving and vehicle miles travelled (VMT) that may result from higher amounts of on-site parking. The TDM measures should specifically focus on strategies that encourage dynamic and context-sensitive pricing solutions and ensure the parking is efficiently allocated, such as providing real time information. Research has demonstrated that charging a user cost for parking or providing a ‘cash-out’ option in return for not using it is the most effective strategy to reduce the instances of drive-alone trips and increase non-auto mode share to further reduce VMT. To ensure the parking is efficiently managed and reduce the need to build parking for future uses, further strategies should include sharing parking with other properties and/or the general public.

D.3. Would the project provide the minimum on and off-site bicycle parking spaces as required by Section 12.21 A.16 of the LAMC?

Yes No

D.4. Does the Project include more than 25,000 square feet of gross floor area construction of new non-residential gross floor?

Yes No

D.5 If the answer to D.4. is YES, does the project comply with the City’s TDM Ordinance in Section 12.26 J of the LAMC?

Yes No N/A

If the answer to **D.3. or D.5. is NO** the project conflicts with LAMC code requirements of bicycle parking and TDM measures. If the project includes uses that require bicycle parking (Section 12.21 A.16) or TDM (Section 12.26 J), and the project does not comply with those Sections of the LAMC, further analysis is required to ensure that the project supports the intent of the two LAMC sections. To meet the intent of

⁴ The baseline parking is defined here as the default parking requirements in section 12.21 A.4 of the Los Angeles Municipal Code or any applicable Specific Plan, whichever prevails, for each applicable use not taking into consideration other parking incentives to reduce the amount of required parking.



Plan, Policy, and Program Consistency Worksheet

bicycle parking requirements, the analysis should identify how the project commits to providing safe access to those traveling by bicycle and accommodates storing their bicycle in locations that demonstrates priority over vehicle access.

Similarly, to meet the intent of the TDM requirements of Section 12.26 J of the LAMC, the analysis should identify how the project commits to providing effective strategies in either physical facilities or programs that encourage non-drive alone trips to and from the project site and changes in work schedule that move trips out of the peak period or eliminate them altogether (as in the case in telecommuting or compressed work weeks).

E. Consistency with Regional Plans

This section addresses potential inconsistencies with greenhouse gas (GHG) reduction targets forecasted in the Southern California Association of Governments (SCAG) Regional Transportation Plan (RTP) / Sustainable Communities Strategy (SCS).

E.1 Does the Project or Plan apply one the City’s efficiency-based impact thresholds (i.e. VMT per capita, VMT per employee, or VMT per service population) as discussed in **Section 2.2.3** of the TAG?
 Yes No

E.2 If the Answer to **E.1 is YES**, does the Project or Plan result in a significant VMT impact?
 Yes No N/A

E.3 If the Answer to **E.1 is NO**, does the Project result in a net increase in VMT?
 Yes No N/A

If the Answer to **E.2 or E.3 is NO**, then the Project or Plan is shown to align with the long-term VMT and GHG reduction goals of SCAG’s RTP/SCS.

E.4 If the Answer to **E.2 or E.3 is YES**, then further evaluation would be necessary to determine whether such a project or land use plan would be shown to be consistent with VMT and GHG reduction goals of the SCAG RTP/SCS. For the purpose of making a finding that a project is consistent with the GHG reduction targets forecasted in the SCAG RTP/SCS, the project analyst should consult **Section 2.2.4** of the Transportation Assessment Guidelines (TAG). **Section 2.2.4** provides the methodology for evaluating a land use project's cumulative impacts to VMT, and the appropriate reliance on SCAG’s most recently adopted RTP/SCS in reaching that conclusion.

The analysis methods therein can further support findings that the project is consistent with the general use designation, density, building intensity, and applicable policies specified for the project area in either a sustainable communities strategy or an alternative planning strategy for which the State Air Resources Board, pursuant to Section 65080(b)(2)(H) of the Government Code, has accepted a metropolitan planning organization's determination that the sustainable communities strategy or the alternative planning strategy would, if implemented, achieve the greenhouse gas emission reduction targets.



Plan, Policy, and Program Consistency Worksheet

References

BOE [Street Standard Dimensions S-470-1](#)

http://eng2.lacity.org/techdocs/stdplans/s-400/S-470-1_20151021_150849.pdf

LADCP [Citywide Design Guidelines](#).

https://planning.lacity.org/odocument/f6608be7-d5fe-4187-bea6-20618eec5049/Citywide_Design_Guidelines.pdf

LADOT Transportation Assessment Support Map <https://arcg.is/fubbD>

Mobility Plan 2035

https://planning.lacity.org/odocument/523f2a95-9d72-41d7-aba5-1972f84c1d36/Mobility_Plan_2035.pdf

SCAG. Connect SoCal, 2020-2045 RTP/SCS, <https://www.connectsocial.org/Pages/default.aspx>

ATTACHMENT D.1: CITY PLAN, POLICIES AND GUIDELINES

The Transportation Element of the City's General Plan, Mobility Plan 2035, established the "Complete Streets Design Guide" as the City's document to guide the operations and design of streets and other public rights-of-way. It lays out a vision for designing safer, more vibrant streets that are accessible to people, no matter what their mode choice. As a living document, it is intended to be frequently updated as City departments identify and implement street standards and experiment with different configurations to promote complete streets. The guide is meant to be a toolkit that provides numerous examples of what is possible in the public right-of-way and that provides guidance on context-sensitive design.

The Plan for A Healthy Los Angeles (March 2015) includes policies directing several City departments to develop plans that promote active transportation and safety.

The City of Los Angeles Community Plans, which make up the Land Use Element of the City's General Plan, guide the physical development of neighborhoods by establishing the goals and policies for land use. The 35 Community Plans provide specific, neighborhood-level detail for land uses and the transportation network, relevant policies, and implementation strategies necessary to achieve General Plan and community-specific objectives.

The stated goal of Vision Zero is to eliminate traffic-related deaths in Los Angeles by 2025 through a number of strategies, including modifying the design of streets to increase the safety of vulnerable road users. Extensive crash data analysis is conducted on an ongoing basis to prioritize intersections and corridors for implementation of projects that will have the greatest effect on overall fatality reduction. The City designs and deploys Vision Zero Corridor Plans as part of the implementation of Vision Zero. If a project is proposed whose site lies on the High Injury Network (HIN), the applicant should consult with LADOT to inform the project's site plan and to determine appropriate improvements, whether by funding their implementation in full or by making a contribution toward their implementation.

The Citywide Design Guidelines (October 24, 2019) includes sections relevant to development projects where improvements are proposed within the public realm. Specifically, Guidelines one through three provide building design strategies that support the pedestrian experience. The Guidelines provide best practices in designing that apply in three spatial categories of site planning, building design and public right of way. The Guidelines should be followed to ensure that the project design supports pedestrian safety, access and comfort as they access to and from the building and the immediate public right of way.

The City's Transportation Demand Management (TDM) Ordinance (LA Municipal Code 12.26.J) requires certain projects to incorporate strategies that reduce drive-alone vehicle trips and improve access to destinations and services. The ordinance is revised and updated periodically and should be reviewed for application to specific projects as they are reviewed.

The City's LAMC Section 12.37 (Waivers of Dedication and Improvement) requires certain projects to dedicate and/or implement improvements within the public right-of-way to meet the street designation standards of the Mobility Plan 2035.

The Bureau of Engineering (BOE) Street Standard Dimensions S-470-1 provides the specific street widths and public right of way dimensions associated with the City's street standards.

Attachment D
VMT Worksheets

CITY OF LOS ANGELES VMT CALCULATOR Version 1.3



Project Screening Criteria: Is this project required to conduct a vehicle miles traveled analysis?

Project Information

Project:

Scenario:

Address:

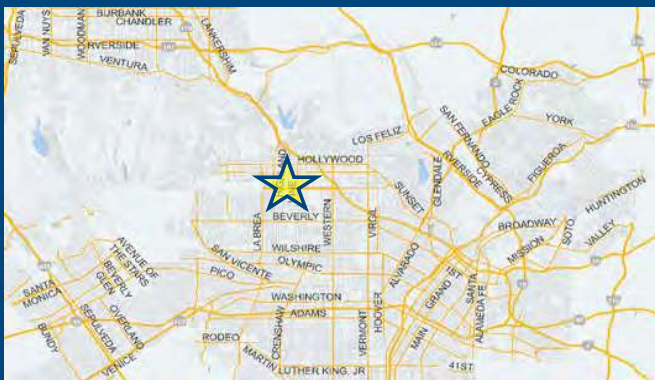

Is the project replacing an existing number of residential units with a smaller number of residential units AND is located within one-half mile of a fixed-rail or fixed-guideway transit

Yes No

Existing Land Use

Land Use Type	Value	Unit
Housing Single Family		DU

[Click here to add a single custom land use type \(will be included in the above list\)](#)

Proposed Project Land Use

Land Use Type	Value	Unit
Retail High-Turnover Sit-Down Restaurant	7	ksf
Housing Multi-Family	135	DU
Housing Affordable Housing - Family	18	DU
Retail High-Turnover Sit-Down Restaurant	7	ksf

[Click here to add a single custom land use type \(will be included in the above list\)](#)

Project Screening Summary

Existing Land Use	Proposed
0 Daily Vehicle Trips	1,025 Daily Vehicle Trips
0 Daily VMT	6,092 Daily VMT
Tier 1 Screening Criteria	
Project will have less residential units compared to existing residential units & is within one-half mile of a fixed-rail station. <input type="checkbox"/>	
Tier 2 Screening Criteria	
The net increase in daily trips < 250 trips	1,025 Net Daily Trips
The net increase in daily VMT ≤ 0	6,092 Net Daily VMT
The proposed project consists of only retail land uses ≤ 50,000 square feet total.	7.000 ksf
The proposed project is required to perform VMT analysis.	



CITY OF LOS ANGELES VMT CALCULATOR Version 1.3



Project Information

Project:

Scenario:

Address:

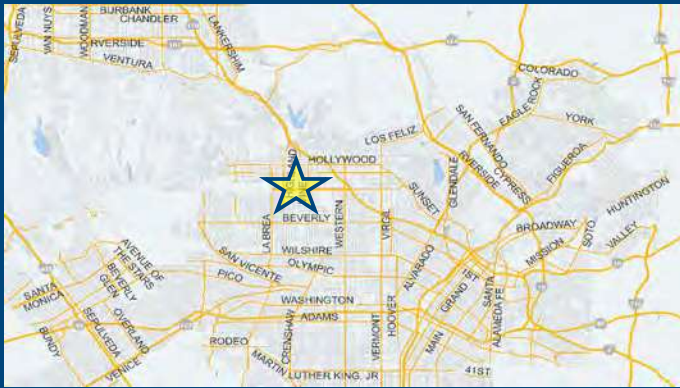

Proposed Project Land Use Type	Value	Unit
Housing Multi-Family	135	DU
Housing Affordable Housing - Family	18	DU
Retail High-Turnover Sit-Down Restaurant	7	ksf

TDM Strategies

Select each section to show individual strategies
Use to denote if the TDM strategy is part of the proposed project or is a mitigation strategy

	Proposed Project	With Mitigation
Max Home Based TDM Achieved?	No	No
Max Work Based TDM Achieved?	No	No

A Parking

B Transit

C Education & Encouragement

D Commute Trip Reductions

E Shared Mobility

F Bicycle Infrastructure

Implement/Improve On-street Bicycle Facility Select Proposed Prj or Mitigation to include this strategy
 Proposed Prj Mitigation

Include Bike Parking Per LAMC Select Proposed Prj or Mitigation to include this strategy
 Proposed Prj Mitigation

Include Secure Bike Parking and Showers Select Proposed Prj or Mitigation to include this strategy
 Proposed Prj Mitigation

G Neighborhood Enhancement

Analysis Results

Proposed Project	With
892 Daily Vehicle Trips	892 Daily Vehicle Trips
5,297 Daily VMT	5,297 Daily VMT
3.7 Household VMT per Capita	3.7 Household VMT
N/A Work VMT per Employee	N/A Work VMT per Employee

Significant VMT Impact?	
Household: No Threshold = 6.0 15% Below APC	Household: No Threshold = 6.0 15% Below APC
Work: N/A Threshold = 7.6 15% Below APC	Work: N/A Threshold = 7.6 15% Below APC



CITY OF LOS ANGELES VMT CALCULATOR

Report 1: Project & Analysis Overview

Date: September 13, 2022

Project Name: 1200 Vine Street

Project Scenario:

Project Address: 1200 N VINE ST, 90038



Version 1.3

Project Information			
Land Use Type		Value	Units
Housing	Single Family	0	DU
	Multi Family	135	DU
	Townhouse	0	DU
	Hotel	0	Rooms
	Motel	0	Rooms
Affordable Housing	Family	18	DU
	Senior	0	DU
	Special Needs	0	DU
	Permanent Supportive	0	DU
Retail	General Retail	0.000	ksf
	Furniture Store	0.000	ksf
	Pharmacy/Drugstore	0.000	ksf
	Supermarket	0.000	ksf
	Bank	0.000	ksf
	Health Club	0.000	ksf
	High-Turnover Sit-Down Restaurant	7.000	ksf
	Fast-Food Restaurant	0.000	ksf
	Quality Restaurant	0.000	ksf
	Auto Repair	0.000	ksf
	Home Improvement	0.000	ksf
	Free-Standing Discount	0.000	ksf
	Movie Theater	0	Seats
	Office	General Office	0.000
Medical Office		0.000	ksf
Industrial	Light Industrial	0.000	ksf
	Manufacturing	0.000	ksf
	Warehousing/Self-Storage	0.000	ksf
School	University	0	Students
	High School	0	Students
	Middle School	0	Students
	Elementary	0	Students
	Private School (K-12)	0	Students
Other		0	Trips

Analysis Results			
Total Employees: 28			
Total Population: 361			
Proposed Project		With Mitigation	
892	Daily Vehicle Trips	892	Daily Vehicle Trips
5,297	Daily VMT	5,297	Daily VMT
3.7	Household VMT per Capita	3.7	Household VMT per Capita
N/A	Work VMT per Employee	N/A	Work VMT per Employee
Significant VMT Impact?			
APC: Central			
Impact Threshold: 15% Below APC Average			
Household = 6.0			
Work = 7.6			
Proposed Project		With Mitigation	
VMT Threshold	Impact	VMT Threshold	Impact
Household > 6.0	No	Household > 6.0	No
Work > 7.6	N/A	Work > 7.6	N/A



TDM Strategy Inputs					
Strategy Type	Description	Proposed Project	Mitigations		
Parking	Reduce parking supply	City code parking provision (spaces)	311	311	
		Actual parking provision (spaces)	93	93	
	Unbundle parking	Monthly cost for parking (\$)	\$0	\$0	
	Parking cash-out	Employees eligible (%)	0%	0%	
		Daily parking charge (\$)	\$0.00	\$0.00	
	Price workplace parking	Employees subject to priced parking (%)	0%	0%	
	Residential area parking permits	Cost of annual permit (\$)	\$0	\$0	
(cont. on following page)					
TDM Strategy Inputs, Cont.					
Strategy Type	Description	Proposed Project	Mitigations		
Transit	Reduce transit headways	Reduction in headways (increase in frequency) (%)	0%	0%	
		Existing transit mode share (as a percent of total daily trips) (%)	0%	0%	
		Lines within project site improved (<50%, >=50%)	0	0	
	Implement neighborhood shuttle	Degree of implementation (low, medium, high)	0	0	
		Employees and residents eligible (%)	0%	0%	
	Transit subsidies	Amount of transit subsidy per passenger (daily equivalent) (\$)	\$0.00	\$0.00	
Education & Encouragement	Voluntary travel behavior change program	Employees and residents participating (%)	0%	0%	
	Promotions and marketing	Employees and residents participating (%)	0%	0%	
(cont. on following page)					
TDM Strategy Inputs, Cont.					
Strategy Type	Description	Proposed Project	Mitigations		
Commuter Trip Reductions	Required commute trip reduction program	Employees participating (%)	0%	0%	
		Type of program	0	0	
	Alternative Work Schedules and Telecommute	Degree of implementation (low, medium, high)	0	0	
		Employer sponsored vanpool or shuttle	Employees eligible (%)	0%	0%
		Employer size (small, medium, large)	0	0	
	Ride-share program	Employees eligible (%)	0%	0%	
Shared Mobility	Car share	Car share project setting (Urban, Suburban, All Other)	0	0	
	Bike share	Within 600 feet of existing bike share station - Or - implementing new bike share station (Yes/No)	0	0	
		School carpool program	Level of implementation (Low, Medium, High)	0	0
(cont. on following page)					
TDM Strategy Inputs, Cont.					
Strategy Type	Description	Proposed Project	Mitigations		
Bicycle Infrastructure	Implement/improve on-street bicycle facility	Provide bicycle facility along site (Yes/No)	0	0	
	Include Bike parking per LAMC	Meets City Bike Parking Code (Yes/No)	Yes	Yes	
	Include secure bike parking and showers	Includes indoor bike parking/lockers, showers, & repair station (Yes/No)	0	0	
Neighborhood Enhancement	Traffic calming improvements	Streets with traffic calming improvements (%)	0%	0%	
		Intersections with traffic calming improvements (%)	0%	0%	
	Pedestrian network improvements	Included (within project and connecting off-site/within project only)	0	0	



Report 3: TDM Outputs

TDM Adjustments by Trip Purpose & Strategy														
Place type: Urban														
		Home Based Work Production		Home Based Work Attraction		Home Based Other Production		Home Based Other Attraction		Non-Home Based Other Production		Non-Home Based Other Attraction		Source
		Proposed	Mitigated	Proposed	Mitigated	Proposed	Mitigated	Proposed	Mitigated	Proposed	Mitigated	Proposed	Mitigated	
Parking	Reduce parking supply	13%	13%	13%	13%	13%	13%	13%	13%	13%	13%	13%	13%	TDM Strategy Appendix, Parking sections 1 - 5
	Unbundle parking	0%	0%	0%	0%	0%	0%	0%	0%	0%	0%	0%	0%	
	Parking cash-out	0%	0%	0%	0%	0%	0%	0%	0%	0%	0%	0%	0%	
	Price workplace parking	0%	0%	0%	0%	0%	0%	0%	0%	0%	0%	0%	0%	
Transit	Residential area parking permits	0.00%	0.00%	0.00%	0.00%	0.00%	0.00%	0.00%	0.00%	0.00%	0.00%	0.00%	0.00%	TDM Strategy Appendix, Transit sections 1 - 3
	Reduce transit headways	0%	0%	0%	0%	0%	0%	0%	0%	0%	0%	0%	0%	
	Implement neighborhood shuttle	0%	0%	0%	0%	0%	0%	0%	0%	0%	0%	0%	0%	
Education & Encouragement	Transit subsidies	0%	0%	0%	0%	0%	0%	0%	0%	0%	0%	0%	0%	TDM Strategy Appendix, Education & Encouragement sections 1 - 2
	Voluntary travel behavior change program	0%	0%	0%	0%	0%	0%	0%	0%	0%	0%	0%	0%	
Commuter Trip Reductions	Promotions and marketing	0%	0%	0%	0%	0%	0%	0%	0%	0%	0%	0%	0%	TDM Strategy Appendix, Commuter Trip Reductions sections 1 - 4
	Required commute trip reduction program	0%	0%	0%	0%	0%	0%	0%	0%	0%	0%	0%	0%	
	Alternative Work Schedules and Telecommute Program	0%	0%	0%	0%	0%	0%	0%	0%	0%	0%	0%	0%	
	Employer sponsored vanpool or shuttle	0%	0%	0%	0%	0%	0%	0%	0%	0%	0%	0%	0%	
Shared Mobility	Ride-share program	0%	0%	0%	0%	0%	0%	0%	0%	0%	0%	0%	0%	TDM Strategy Appendix, Shared Mobility sections 1 - 3
	Car-share	0.00%	0.00%	0.00%	0.00%	0.00%	0.00%	0.00%	0.00%	0.00%	0.00%	0.00%	0.00%	
	Bike share	0.00%	0.00%	0.00%	0.00%	0.00%	0.00%	0.00%	0.00%	0.00%	0.00%	0.00%	0.00%	
	School carpool program	0.0%	0.0%	0.0%	0.0%	0.0%	0.0%	0.0%	0.0%	0.0%	0.0%	0.0%		

TDM Adjustments by Trip Purpose & Strategy, Cont.														
Place type: Urban														
		Home Based Work Production		Home Based Work Attraction		Home Based Other Production		Home Based Other Attraction		Non-Home Based Other Production		Non-Home Based Other Attraction		Source
		Proposed	Mitigated	Proposed	Mitigated	Proposed	Mitigated	Proposed	Mitigated	Proposed	Mitigated	Proposed	Mitigated	
Bicycle Infrastructure	Implement/ Improve on-street bicycle facility	0.0%	0.0%	0.0%	0.0%	0.0%	0.0%	0.0%	0.0%	0.0%	0.0%	0.0%	0.0%	TDM Strategy Appendix, Bicycle Infrastructure sections 1 - 3
	Include Bike parking per LAMC	0.6%	0.6%	0.6%	0.6%	0.6%	0.6%	0.6%	0.6%	0.6%	0.6%	0.6%	0.6%	
	Include secure bike parking and showers	0.0%	0.0%	0.0%	0.0%	0.0%	0.0%	0.0%	0.0%	0.0%	0.0%	0.0%	0.0%	
Neighborhood Enhancement	Traffic calming improvements	0.0%	0.0%	0.0%	0.0%	0.0%	0.0%	0.0%	0.0%	0.0%	0.0%	0.0%	0.0%	TDM Strategy Appendix, Neighborhood Enhancement
	Pedestrian network improvements	0.0%	0.0%	0.0%	0.0%	0.0%	0.0%	0.0%	0.0%	0.0%	0.0%	0.0%	0.0%	

Final Combined & Maximum TDM Effect														
		Home Based Work Production		Home Based Work Attraction		Home Based Other Production		Home Based Other Attraction		Non-Home Based Other Production		Non-Home Based Other Attraction		
		Proposed	Mitigated	Proposed	Mitigated	Proposed	Mitigated	Proposed	Mitigated	Proposed	Mitigated	Proposed	Mitigated	
COMBINED TOTAL		13%	13%	13%	13%	13%	13%	13%	13%	13%	13%	13%	13%	
MAX. TDM EFFECT		13%	13%	13%	13%	13%	13%	13%	13%	13%	13%	13%	13%	

$$= \text{Minimum}(X\%, 1 - [(1-A) * (1-B)...])$$

where X%=

PLACE	urban	75%
PLACE TYPE MAX:	compact infill	40%
	suburban center	20%
	suburban	15%

Note: (1-[(1-A)*(1-B)...]) reflects the dampened combined effectiveness of TDM Strategies (e.g., A, B,...). See the TDM Strategy Appendix (Transportation Assessment Guidelines Attachment G) for further discussion of dampening.

CITY OF LOS ANGELES VMT CALCULATOR

Report 4: MXD Methodology

Date: September 13, 2022

Project Name: 1200 Vine Street

Project Scenario:

Project Address: 1200 N VINE ST, 90038



Version 1.3

MXD Methodology - Project Without TDM

	Unadjusted Trips	MXD Adjustment	MXD Trips	Average Trip Length	Unadjusted VMT	MXD VMT
Home Based Work Production	136	-31.6%	93	7.1	966	660
Home Based Other Production	377	-48.3%	195	4.4	1,659	858
Non-Home Based Other Production	306	-6.9%	285	6.9	2,111	1,967
Home-Based Work Attraction	41	-48.8%	21	8.5	349	179
Home-Based Other Attraction	477	-43.0%	272	5.3	2,528	1,442
Non-Home Based Other Attraction	172	-7.6%	159	6.2	1,066	986

MXD Methodology with TDM Measures

	<i>Proposed Project</i>			<i>Project with Mitigation Measures</i>		
	TDM Adjustment	Project Trips	Project VMT	TDM Adjustment	Mitigated Trips	Mitigated VMT
Home Based Work Production	-13.0%	81	574	-13.0%	81	574
Home Based Other Production	-13.0%	170	746	-13.0%	170	746
Non-Home Based Other Production	-13.0%	248	1,710	-13.0%	248	1,710
Home-Based Work Attraction	-13.0%	18	156	-13.0%	18	156
Home-Based Other Attraction	-13.0%	237	1,254	-13.0%	237	1,254
Non-Home Based Other Attraction	-13.0%	138	857	-13.0%	138	857

MXD VMT Methodology Per Capita & Per Employee

Total Population: 361

Total Employees: 28

APC: Central

	<i>Proposed Project</i>	<i>Project with Mitigation Measures</i>
<i>Total Home Based Production VMT</i>	1,320	1,320
<i>Total Home Based Work Attraction VMT</i>	156	156
<i>Total Home Based VMT Per Capita</i>	3.7	3.7
<i>Total Work Based VMT Per Employee</i>	N/A	N/A

Attachment E
HCM Worksheets

HCM 6th Signalized Intersection Summary

1: Vine St & Fountain Ave

10/14/2022



Movement	EBL	EBT	EBR	WBL	WBT	WBR	NBL	NBT	NBR	SBL	SBT	SBR
Lane Configurations	↖	↗		↖	↗		↖	↕		↖	↗	
Traffic Volume (veh/h)	72	237	43	79	414	45	41	988	39	21	1293	87
Future Volume (veh/h)	72	237	43	79	414	45	41	988	39	21	1293	87
Initial Q (Qb), veh	0	0	0	0	0	0	0	0	0	0	0	0
Ped-Bike Adj(A_pbT)	1.00		1.00	1.00		1.00	1.00		1.00	1.00		1.00
Parking Bus, Adj	1.00	1.00	1.00	1.00	1.00	1.00	1.00	1.00	1.00	1.00	1.00	1.00
Work Zone On Approach		No			No			No			No	
Adj Sat Flow, veh/h/ln	1870	1870	1870	1870	1870	1870	1870	1870	1870	1870	1870	1870
Adj Flow Rate, veh/h	78	258	47	86	450	49	45	1074	42	23	1405	95
Peak Hour Factor	0.92	0.92	0.92	0.92	0.92	0.92	0.92	0.92	0.92	0.92	0.92	0.92
Percent Heavy Veh, %	2	2	2	2	2	2	2	2	2	2	2	2
Cap, veh/h	177	538	98	315	580	63	152	1872	73	351	1814	122
Arrive On Green	0.35	0.35	0.35	0.35	0.35	0.35	1.00	1.00	1.00	0.54	0.54	0.54
Sat Flow, veh/h	899	1539	280	1074	1657	180	350	3486	136	505	3379	228
Grp Volume(v), veh/h	78	0	305	86	0	499	45	547	569	23	737	763
Grp Sat Flow(s),veh/h/ln	899	0	1820	1074	0	1838	350	1777	1846	505	1777	1829
Q Serve(g_s), s	7.6	0.0	11.8	6.1	0.0	21.8	9.4	0.0	0.0	2.0	29.5	29.8
Cycle Q Clear(g_c), s	29.4	0.0	11.8	17.9	0.0	21.8	39.2	0.0	0.0	2.0	29.5	29.8
Prop In Lane	1.00		0.15	1.00		0.10	1.00		0.07	1.00		0.12
Lane Grp Cap(c), veh/h	177	0	637	315	0	643	152	954	991	351	954	982
V/C Ratio(X)	0.44	0.00	0.48	0.27	0.00	0.78	0.30	0.57	0.57	0.07	0.77	0.78
Avail Cap(c_a), veh/h	178	0	639	317	0	645	152	954	991	351	954	982
HCM Platoon Ratio	1.00	1.00	1.00	1.00	1.00	1.00	2.00	2.00	2.00	1.00	1.00	1.00
Upstream Filter(I)	1.00	0.00	1.00	1.00	0.00	1.00	1.00	1.00	1.00	1.00	1.00	1.00
Uniform Delay (d), s/veh	39.3	0.0	22.9	29.8	0.0	26.1	12.1	0.0	0.0	10.1	16.5	16.6
Incr Delay (d2), s/veh	1.7	0.0	0.6	0.5	0.0	5.9	4.9	2.5	2.4	0.4	6.0	6.0
Initial Q Delay(d3),s/veh	0.0	0.0	0.0	0.0	0.0	0.0	0.0	0.0	0.0	0.0	0.0	0.0
%ile BackOfQ(95%),veh/ln	3.1	0.0	8.7	2.9	0.0	15.5	1.4	1.2	1.2	0.4	18.3	19.0
Unsig. Movement Delay, s/veh												
LnGrp Delay(d),s/veh	41.0	0.0	23.4	30.3	0.0	32.0	17.0	2.5	2.4	10.5	22.5	22.6
LnGrp LOS	D	A	C	C	A	C	B	A	A	B	C	C
Approach Vol, veh/h		383			585			1161			1523	
Approach Delay, s/veh		27.0			31.8			3.0			22.4	
Approach LOS		C			C			A			C	
Timer - Assigned Phs		2		4		6		8				
Phs Duration (G+Y+Rc), s		53.1		36.9		53.1		36.9				
Change Period (Y+Rc), s		* 4.8		* 5.4		* 4.8		* 5.4				
Max Green Setting (Gmax), s		* 48		* 32		* 48		* 32				
Max Q Clear Time (g_c+I1), s		41.2		31.4		31.8		23.8				
Green Ext Time (p_c), s		4.2		0.0		10.0		2.2				

Intersection Summary

HCM 6th Ctrl Delay	18.2
HCM 6th LOS	B

Notes

* HCM 6th computational engine requires equal clearance times for the phases crossing the barrier.

HCM 6th Signalized Intersection Summary

2: Vine St & Lexington Ave

10/14/2022



Movement	EBL	EBT	EBR	WBL	WBT	WBR	NBL	NBT	NBR	SBL	SBT	SBR
Lane Configurations		↕			↕		↙	↕		↙	↕	
Traffic Volume (veh/h)	19	34	33	28	70	29	26	1035	15	17	1297	53
Future Volume (veh/h)	19	34	33	28	70	29	26	1035	15	17	1297	53
Initial Q (Qb), veh	0	0	0	0	0	0	0	0	0	0	0	0
Ped-Bike Adj(A_pbT)	1.00		1.00	1.00		1.00	1.00		1.00	1.00		1.00
Parking Bus, Adj	1.00	1.00	1.00	1.00	1.00	1.00	1.00	1.00	1.00	1.00	1.00	1.00
Work Zone On Approach		No			No			No			No	
Adj Sat Flow, veh/h/ln	1870	1870	1870	1870	1870	1870	1870	1870	1870	1870	1870	1870
Adj Flow Rate, veh/h	21	37	36	30	76	32	28	1125	16	18	1410	58
Peak Hour Factor	0.92	0.92	0.92	0.92	0.92	0.92	0.92	0.92	0.92	0.92	0.92	0.92
Percent Heavy Veh, %	2	2	2	2	2	2	2	2	2	2	2	2
Cap, veh/h	75	86	70	77	111	42	363	2814	40	418	2729	112
Arrive On Green	0.10	0.10	0.10	0.10	0.10	0.10	0.78	0.78	0.78	1.00	1.00	1.00
Sat Flow, veh/h	253	824	669	269	1062	402	361	3587	51	493	3479	143
Grp Volume(v), veh/h	94	0	0	138	0	0	28	557	584	18	719	749
Grp Sat Flow(s),veh/h/ln	1746	0	0	1733	0	0	361	1777	1861	493	1777	1845
Q Serve(g_s), s	0.0	0.0	0.0	2.3	0.0	0.0	1.6	8.9	8.9	0.4	0.0	0.0
Cycle Q Clear(g_c), s	4.5	0.0	0.0	6.8	0.0	0.0	1.6	8.9	8.9	9.3	0.0	0.0
Prop In Lane	0.22		0.38	0.22		0.23	1.00		0.03	1.00		0.08
Lane Grp Cap(c), veh/h	231	0	0	230	0	0	363	1394	1460	418	1394	1447
V/C Ratio(X)	0.41	0.00	0.00	0.60	0.00	0.00	0.08	0.40	0.40	0.04	0.52	0.52
Avail Cap(c_a), veh/h	483	0	0	491	0	0	363	1394	1460	418	1394	1447
HCM Platoon Ratio	1.00	1.00	1.00	1.00	1.00	1.00	1.00	1.00	1.00	2.00	2.00	2.00
Upstream Filter(I)	1.00	0.00	0.00	1.00	0.00	0.00	1.00	1.00	1.00	1.00	1.00	1.00
Uniform Delay (d), s/veh	38.1	0.0	0.0	39.1	0.0	0.0	2.3	3.0	3.0	0.6	0.0	0.0
Incr Delay (d2), s/veh	1.1	0.0	0.0	2.5	0.0	0.0	0.4	0.9	0.8	0.2	1.4	1.3
Initial Q Delay(d3),s/veh	0.0	0.0	0.0	0.0	0.0	0.0	0.0	0.0	0.0	0.0	0.0	0.0
%ile BackOfQ(95%),veh/ln	3.6	0.0	0.0	5.5	0.0	0.0	0.2	4.2	4.4	0.0	1.0	1.0
Unsig. Movement Delay, s/veh												
LnGrp Delay(d),s/veh	39.3	0.0	0.0	41.6	0.0	0.0	2.7	3.9	3.9	0.8	1.4	1.3
LnGrp LOS	D	A	A	D	A	A	A	A	A	A	A	A
Approach Vol, veh/h		94			138			1169			1486	
Approach Delay, s/veh		39.3			41.6			3.9			1.3	
Approach LOS		D			D			A			A	
Timer - Assigned Phs		2		4		6		8				
Phs Duration (G+Y+Rc), s		75.2		14.8		75.2		14.8				
Change Period (Y+Rc), s		4.6		* 5.4		4.6		* 5.4				
Max Green Setting (Gmax), s		56.4		* 24		56.4		* 24				
Max Q Clear Time (g_c+I1), s		10.9		6.5		11.3		8.8				
Green Ext Time (p_c), s		23.7		0.4		31.5		0.6				

Intersection Summary

HCM 6th Ctrl Delay	5.5
HCM 6th LOS	A

Notes

* HCM 6th computational engine requires equal clearance times for the phases crossing the barrier.

HCM 6th Signalized Intersection Summary

1: Vine St & Fountain Ave

10/14/2022



Movement	EBL	EBT	EBR	WBL	WBT	WBR	NBL	NBT	NBR	SBL	SBT	SBR
Lane Configurations	↖	↗		↖	↗		↖	↕		↖	↗	
Traffic Volume (veh/h)	125	524	45	81	339	52	59	1177	58	51	1108	106
Future Volume (veh/h)	125	524	45	81	339	52	59	1177	58	51	1108	106
Initial Q (Qb), veh	0	0	0	0	0	0	0	0	0	0	0	0
Ped-Bike Adj(A_pbT)	1.00		1.00	1.00		1.00	1.00		1.00	1.00		1.00
Parking Bus, Adj	1.00	1.00	1.00	1.00	1.00	1.00	1.00	1.00	1.00	1.00	1.00	1.00
Work Zone On Approach		No			No			No			No	
Adj Sat Flow, veh/h/ln	1870	1870	1870	1870	1870	1870	1870	1870	1870	1870	1870	1870
Adj Flow Rate, veh/h	136	570	49	88	368	57	64	1279	63	55	1204	115
Peak Hour Factor	0.92	0.92	0.92	0.92	0.92	0.92	0.92	0.92	0.92	0.92	0.92	0.92
Percent Heavy Veh, %	2	2	2	2	2	2	2	2	2	2	2	2
Cap, veh/h	284	672	58	153	626	97	161	1693	83	270	1610	153
Arrive On Green	0.40	0.40	0.40	0.40	0.40	0.40	0.98	0.98	0.98	0.49	0.49	0.49
Sat Flow, veh/h	962	1698	146	804	1581	245	416	3447	170	407	3278	312
Grp Volume(v), veh/h	136	0	619	88	0	425	64	659	683	55	651	668
Grp Sat Flow(s),veh/h/ln	962	0	1844	804	0	1826	416	1777	1840	407	1777	1814
Q Serve(g_s), s	11.7	0.0	27.5	8.1	0.0	16.5	12.2	2.3	2.3	7.5	26.5	26.7
Cycle Q Clear(g_c), s	28.2	0.0	27.5	35.6	0.0	16.5	38.9	2.3	2.3	9.8	26.5	26.7
Prop In Lane	1.00		0.08	1.00		0.13	1.00		0.09	1.00		0.17
Lane Grp Cap(c), veh/h	284	0	729	153	0	722	161	873	904	270	873	891
V/C Ratio(X)	0.48	0.00	0.85	0.58	0.00	0.59	0.40	0.75	0.76	0.20	0.75	0.75
Avail Cap(c_a), veh/h	284	0	729	153	0	722	161	873	904	270	873	891
HCM Platoon Ratio	1.00	1.00	1.00	1.00	1.00	1.00	2.00	2.00	2.00	1.00	1.00	1.00
Upstream Filter(I)	1.00	0.00	1.00	1.00	0.00	1.00	1.00	1.00	1.00	1.00	1.00	1.00
Uniform Delay (d), s/veh	32.5	0.0	24.7	41.7	0.0	21.4	12.5	0.4	0.4	14.9	18.4	18.4
Incr Delay (d2), s/veh	1.2	0.0	9.3	5.3	0.0	1.3	7.2	6.0	5.9	1.7	5.8	5.7
Initial Q Delay(d3),s/veh	0.0	0.0	0.0	0.0	0.0	0.0	0.0	0.0	0.0	0.0	0.0	0.0
%ile BackOfQ(95%),veh/ln	5.0	0.0	19.2	3.9	0.0	11.4	2.2	3.0	3.1	1.4	17.1	17.4
Unsig. Movement Delay, s/veh												
LnGrp Delay(d),s/veh	33.8	0.0	34.0	46.9	0.0	22.7	19.7	6.4	6.3	16.6	24.2	24.2
LnGrp LOS	C	A	C	D	A	C	B	A	A	B	C	C
Approach Vol, veh/h		755			513			1406			1374	
Approach Delay, s/veh		34.0			26.8			7.0			23.9	
Approach LOS		C			C			A			C	
Timer - Assigned Phs		2		4		6		8				
Phs Duration (G+Y+Rc), s		49.0		41.0		49.0		41.0				
Change Period (Y+Rc), s		* 4.8		* 5.4		* 4.8		* 5.4				
Max Green Setting (Gmax), s		* 44		* 36		* 44		* 36				
Max Q Clear Time (g_c+I1), s		40.9		30.2		28.7		37.6				
Green Ext Time (p_c), s		2.6		2.3		8.8		0.0				

Intersection Summary

HCM 6th Ctrl Delay	20.3
HCM 6th LOS	C

Notes

* HCM 6th computational engine requires equal clearance times for the phases crossing the barrier.

HCM 6th Signalized Intersection Summary

2: Vine St & Lexington Ave

10/14/2022



Movement	EBL	EBT	EBR	WBL	WBT	WBR	NBL	NBT	NBR	SBL	SBT	SBR
Lane Configurations		↕			↕		↙	↕		↙	↕	
Traffic Volume (veh/h)	42	125	47	21	46	53	18	1197	37	27	1221	29
Future Volume (veh/h)	42	125	47	21	46	53	18	1197	37	27	1221	29
Initial Q (Qb), veh	0	0	0	0	0	0	0	0	0	0	0	0
Ped-Bike Adj(A_pbT)	1.00		1.00	1.00		1.00	1.00		1.00	1.00		1.00
Parking Bus, Adj	1.00	1.00	1.00	1.00	1.00	1.00	1.00	1.00	1.00	1.00	1.00	1.00
Work Zone On Approach		No			No			No			No	
Adj Sat Flow, veh/h/ln	1870	1870	1870	1870	1870	1870	1870	1870	1870	1870	1870	1870
Adj Flow Rate, veh/h	46	136	51	23	50	58	20	1301	40	29	1327	32
Peak Hour Factor	0.92	0.92	0.92	0.92	0.92	0.92	0.92	0.92	0.92	0.92	0.92	0.92
Percent Heavy Veh, %	2	2	2	2	2	2	2	2	2	2	2	2
Cap, veh/h	89	178	61	75	126	122	371	2556	79	311	2576	62
Arrive On Green	0.16	0.16	0.16	0.16	0.16	0.16	0.73	0.73	0.73	1.00	1.00	1.00
Sat Flow, veh/h	250	1097	378	174	773	753	401	3520	108	408	3546	85
Grp Volume(v), veh/h	233	0	0	131	0	0	20	656	685	29	664	695
Grp Sat Flow(s),veh/h/ln	725	0	0	1700	0	0	401	1777	1851	408	1777	1855
Q Serve(g_s), s	5.5	0.0	0.0	0.0	0.0	0.0	1.3	14.4	14.5	1.6	0.0	0.0
Cycle Q Clear(g_c), s	11.6	0.0	0.0	6.2	0.0	0.0	1.3	14.4	14.5	16.0	0.0	0.0
Prop In Lane	0.20		0.22	0.18		0.44	1.00		0.06	1.00		0.05
Lane Grp Cap(c), veh/h	328	0	0	323	0	0	371	1290	1344	311	1290	1347
V/C Ratio(X)	0.71	0.00	0.00	0.41	0.00	0.00	0.05	0.51	0.51	0.09	0.51	0.52
Avail Cap(c_a), veh/h	530	0	0	517	0	0	371	1290	1344	311	1290	1347
HCM Platoon Ratio	1.00	1.00	1.00	1.00	1.00	1.00	1.00	1.00	1.00	2.00	2.00	2.00
Upstream Filter(I)	1.00	0.00	0.00	1.00	0.00	0.00	1.00	1.00	1.00	1.00	1.00	1.00
Uniform Delay (d), s/veh	36.3	0.0	0.0	34.1	0.0	0.0	3.5	5.3	5.4	1.8	0.0	0.0
Incr Delay (d2), s/veh	2.8	0.0	0.0	0.8	0.0	0.0	0.3	1.4	1.4	0.6	1.5	1.4
Initial Q Delay(d3),s/veh	0.0	0.0	0.0	0.0	0.0	0.0	0.0	0.0	0.0	0.0	0.0	0.0
%ile BackOfQ(95%),veh/ln	8.8	0.0	0.0	4.7	0.0	0.0	0.2	8.2	8.4	0.2	0.9	1.0
Unsig. Movement Delay, s/veh												
LnGrp Delay(d),s/veh	39.1	0.0	0.0	35.0	0.0	0.0	3.8	6.8	6.7	2.4	1.5	1.4
LnGrp LOS	D	A	A	C	A	A	A	A	A	A	A	A
Approach Vol, veh/h		233			131			1361			1388	
Approach Delay, s/veh		39.1			35.0			6.7			1.5	
Approach LOS		D			C			A			A	
Timer - Assigned Phs		2		4		6		8				
Phs Duration (G+Y+Rc), s		70.0		20.0		70.0		20.0				
Change Period (Y+Rc), s		4.6		* 5.4		4.6		* 5.4				
Max Green Setting (Gmax), s		54.4		* 26		54.4		* 26				
Max Q Clear Time (g_c+I1), s		16.5		13.6		18.0		8.2				
Green Ext Time (p_c), s		25.4		1.0		25.2		0.6				

Intersection Summary

HCM 6th Ctrl Delay	8.0
HCM 6th LOS	A

Notes

* HCM 6th computational engine requires equal clearance times for the phases crossing the barrier.

HCM 6th Signalized Intersection Summary

1: Vine St & Fountain Ave

10/14/2022



Movement	EBL	EBT	EBR	WBL	WBT	WBR	NBL	NBT	NBR	SBL	SBT	SBR
Lane Configurations	↖	↗		↖	↗		↖	↕		↖	↗	
Traffic Volume (veh/h)	72	237	44	79	414	45	47	1004	63	30	1295	87
Future Volume (veh/h)	72	237	44	79	414	45	47	1004	63	30	1295	87
Initial Q (Qb), veh	0	0	0	0	0	0	0	0	0	0	0	0
Ped-Bike Adj(A_pbT)	1.00		1.00	1.00		1.00	1.00		1.00	1.00		1.00
Parking Bus, Adj	1.00	1.00	1.00	1.00	1.00	1.00	1.00	1.00	1.00	1.00	1.00	1.00
Work Zone On Approach		No			No			No			No	
Adj Sat Flow, veh/h/ln	1870	1870	1870	1870	1870	1870	1870	1870	1870	1870	1870	1870
Adj Flow Rate, veh/h	78	258	48	86	450	49	51	1091	68	33	1408	95
Peak Hour Factor	0.92	0.92	0.92	0.92	0.92	0.92	0.92	0.92	0.92	0.92	0.92	0.92
Percent Heavy Veh, %	2	2	2	2	2	2	2	2	2	2	2	2
Cap, veh/h	177	536	100	314	580	63	151	1824	114	340	1814	122
Arrive On Green	0.35	0.35	0.35	0.35	0.35	0.35	1.00	1.00	1.00	0.54	0.54	0.54
Sat Flow, veh/h	899	1534	285	1073	1657	180	349	3397	212	485	3379	227
Grp Volume(v), veh/h	78	0	306	86	0	499	51	570	589	33	738	765
Grp Sat Flow(s),veh/h/ln	899	0	1819	1073	0	1838	349	1777	1832	485	1777	1829
Q Serve(g_s), s	7.6	0.0	11.8	6.1	0.0	21.8	11.2	0.0	0.0	3.0	29.6	29.9
Cycle Q Clear(g_c), s	29.4	0.0	11.8	18.0	0.0	21.8	41.2	0.0	0.0	3.0	29.6	29.9
Prop In Lane	1.00		0.16	1.00		0.10	1.00		0.12	1.00		0.12
Lane Grp Cap(c), veh/h	177	0	636	314	0	643	151	954	984	340	954	982
V/C Ratio(X)	0.44	0.00	0.48	0.27	0.00	0.78	0.34	0.60	0.60	0.10	0.77	0.78
Avail Cap(c_a), veh/h	178	0	639	316	0	645	151	954	984	340	954	982
HCM Platoon Ratio	1.00	1.00	1.00	1.00	1.00	1.00	2.00	2.00	2.00	1.00	1.00	1.00
Upstream Filter(I)	1.00	0.00	1.00	1.00	0.00	1.00	1.00	1.00	1.00	1.00	1.00	1.00
Uniform Delay (d), s/veh	39.3	0.0	22.9	29.9	0.0	26.1	12.8	0.0	0.0	10.4	16.5	16.6
Incr Delay (d2), s/veh	1.7	0.0	0.6	0.5	0.0	5.9	5.9	2.8	2.7	0.6	6.1	6.1
Initial Q Delay(d3),s/veh	0.0	0.0	0.0	0.0	0.0	0.0	0.0	0.0	0.0	0.0	0.0	0.0
%ile BackOfQ(95%),veh/ln	3.1	0.0	8.7	2.9	0.0	15.5	1.7	1.3	1.3	0.6	18.4	19.0
Unsig. Movement Delay, s/veh												
LnGrp Delay(d),s/veh	41.0	0.0	23.4	30.4	0.0	32.0	18.7	2.8	2.7	10.9	22.6	22.7
LnGrp LOS	D	A	C	C	A	C	B	A	A	B	C	C
Approach Vol, veh/h		384			585			1210			1536	
Approach Delay, s/veh		27.0			31.8			3.4			22.4	
Approach LOS		C			C			A			C	
Timer - Assigned Phs		2		4		6		8				
Phs Duration (G+Y+Rc), s		53.1		36.9		53.1		36.9				
Change Period (Y+Rc), s		* 4.8		* 5.4		* 4.8		* 5.4				
Max Green Setting (Gmax), s		* 48		* 32		* 48		* 32				
Max Q Clear Time (g_c+I1), s		43.2		31.4		31.9		23.8				
Green Ext Time (p_c), s		3.4		0.0		10.0		2.2				

Intersection Summary

HCM 6th Ctrl Delay	18.2
HCM 6th LOS	B

Notes

* HCM 6th computational engine requires equal clearance times for the phases crossing the barrier.

HCM 6th Signalized Intersection Summary

2: Vine St & Lexington Ave

10/14/2022



Movement	EBL	EBT	EBR	WBL	WBT	WBR	NBL	NBT	NBR	SBL	SBT	SBR
Lane Configurations		↕			↕		↙	↕		↙	↕	
Traffic Volume (veh/h)	28	35	33	44	80	56	26	1044	17	20	1297	53
Future Volume (veh/h)	28	35	33	44	80	56	26	1044	17	20	1297	53
Initial Q (Qb), veh	0	0	0	0	0	0	0	0	0	0	0	0
Ped-Bike Adj(A_pbT)	1.00		1.00	1.00		1.00	1.00		1.00	1.00		1.00
Parking Bus, Adj	1.00	1.00	1.00	1.00	1.00	1.00	1.00	1.00	1.00	1.00	1.00	1.00
Work Zone On Approach		No			No			No			No	
Adj Sat Flow, veh/h/ln	1870	1870	1870	1870	1870	1870	1870	1870	1870	1870	1870	1870
Adj Flow Rate, veh/h	30	38	36	48	87	61	28	1135	18	22	1410	58
Peak Hour Factor	0.92	0.92	0.92	0.92	0.92	0.92	0.92	0.92	0.92	0.92	0.92	0.92
Percent Heavy Veh, %	2	2	2	2	2	2	2	2	2	2	2	2
Cap, veh/h	96	110	82	95	120	75	349	2673	42	387	2597	107
Arrive On Green	0.14	0.14	0.14	0.14	0.14	0.14	0.75	0.75	0.75	1.00	1.00	1.00
Sat Flow, veh/h	311	775	575	316	847	525	361	3580	57	487	3479	143
Grp Volume(v), veh/h	104	0	0	196	0	0	28	563	590	22	719	749
Grp Sat Flow(s),veh/h/ln	1661	0	0	1688	0	0	361	1777	1860	487	1777	1845
Q Serve(g_s), s	0.0	0.0	0.0	5.1	0.0	0.0	1.9	10.6	10.6	0.7	0.0	0.0
Cycle Q Clear(g_c), s	4.9	0.0	0.0	10.0	0.0	0.0	1.9	10.6	10.6	11.3	0.0	0.0
Prop In Lane	0.29		0.35	0.24		0.31	1.00		0.03	1.00		0.08
Lane Grp Cap(c), veh/h	288	0	0	290	0	0	349	1327	1389	387	1327	1377
V/C Ratio(X)	0.36	0.00	0.00	0.68	0.00	0.00	0.08	0.42	0.42	0.06	0.54	0.54
Avail Cap(c_a), veh/h	473	0	0	484	0	0	349	1327	1389	387	1327	1377
HCM Platoon Ratio	1.00	1.00	1.00	1.00	1.00	1.00	1.00	1.00	1.00	2.00	2.00	2.00
Upstream Filter(I)	1.00	0.00	0.00	1.00	0.00	0.00	1.00	1.00	1.00	1.00	1.00	1.00
Uniform Delay (d), s/veh	35.2	0.0	0.0	37.3	0.0	0.0	3.1	4.2	4.2	0.9	0.0	0.0
Incr Delay (d2), s/veh	0.8	0.0	0.0	2.8	0.0	0.0	0.4	1.0	1.0	0.3	1.6	1.5
Initial Q Delay(d3),s/veh	0.0	0.0	0.0	0.0	0.0	0.0	0.0	0.0	0.0	0.0	0.0	0.0
%ile BackOfQ(95%),veh/ln	8.8	0.0	0.0	7.7	0.0	0.0	0.3	5.8	6.0	0.1	1.1	1.1
Unsig. Movement Delay, s/veh												
LnGrp Delay(d),s/veh	36.0	0.0	0.0	40.0	0.0	0.0	3.6	5.2	5.2	1.2	1.6	1.5
LnGrp LOS	D	A	A	D	A	A	A	A	A	A	A	A
Approach Vol, veh/h		104			196			1181			1490	
Approach Delay, s/veh		36.0			40.0			5.2			1.6	
Approach LOS		D			D			A			A	
Timer - Assigned Phs		2		4		6		8				
Phs Duration (G+Y+Rc), s		71.8		18.2		71.8		18.2				
Change Period (Y+Rc), s		4.6		* 5.4		4.6		* 5.4				
Max Green Setting (Gmax), s		56.4		* 24		56.4		* 24				
Max Q Clear Time (g_c+I1), s		12.6		6.9		13.3		12.0				
Green Ext Time (p_c), s		23.5		0.4		30.6		0.8				

Intersection Summary

HCM 6th Ctrl Delay	6.7
HCM 6th LOS	A

Notes

* HCM 6th computational engine requires equal clearance times for the phases crossing the barrier.

HCM 6th Signalized Intersection Summary

1: Vine St & Fountain Ave

10/14/2022



Movement	EBL	EBT	EBR	WBL	WBT	WBR	NBL	NBT	NBR	SBL	SBT	SBR
Lane Configurations	↗	↘		↗	↘		↗	↕		↗	↘	
Traffic Volume (veh/h)	125	524	47	81	339	52	63	1188	76	62	1113	106
Future Volume (veh/h)	125	524	47	81	339	52	63	1188	76	62	1113	106
Initial Q (Qb), veh	0	0	0	0	0	0	0	0	0	0	0	0
Ped-Bike Adj(A_pbT)	1.00		1.00	1.00		1.00	1.00		1.00	1.00		1.00
Parking Bus, Adj	1.00	1.00	1.00	1.00	1.00	1.00	1.00	1.00	1.00	1.00	1.00	1.00
Work Zone On Approach		No			No			No			No	
Adj Sat Flow, veh/h/ln	1870	1870	1870	1870	1870	1870	1870	1870	1870	1870	1870	1870
Adj Flow Rate, veh/h	136	570	51	88	368	57	68	1291	83	67	1210	115
Peak Hour Factor	0.92	0.92	0.92	0.92	0.92	0.92	0.92	0.92	0.92	0.92	0.92	0.92
Percent Heavy Veh, %	2	2	2	2	2	2	2	2	2	2	2	2
Cap, veh/h	284	669	60	151	626	97	160	1665	107	263	1611	153
Arrive On Green	0.40	0.40	0.40	0.40	0.40	0.40	0.98	0.98	0.98	0.49	0.49	0.49
Sat Flow, veh/h	962	1692	151	803	1581	245	414	3390	218	395	3280	311
Grp Volume(v), veh/h	136	0	621	88	0	425	68	675	699	67	654	671
Grp Sat Flow(s),veh/h/ln	962	0	1843	803	0	1826	414	1777	1831	395	1777	1814
Q Serve(g_s), s	11.7	0.0	27.6	8.0	0.0	16.5	13.5	2.5	2.6	9.9	26.7	26.9
Cycle Q Clear(g_c), s	28.2	0.0	27.6	35.6	0.0	16.5	40.4	2.5	2.6	12.5	26.7	26.9
Prop In Lane	1.00		0.08	1.00		0.13	1.00		0.12	1.00		0.17
Lane Grp Cap(c), veh/h	284	0	729	151	0	722	160	873	899	263	873	891
V/C Ratio(X)	0.48	0.00	0.85	0.58	0.00	0.59	0.43	0.77	0.78	0.26	0.75	0.75
Avail Cap(c_a), veh/h	284	0	729	151	0	722	160	873	899	263	873	891
HCM Platoon Ratio	1.00	1.00	1.00	1.00	1.00	1.00	2.00	2.00	2.00	1.00	1.00	1.00
Upstream Filter(I)	1.00	0.00	1.00	1.00	0.00	1.00	1.00	1.00	1.00	1.00	1.00	1.00
Uniform Delay (d), s/veh	32.5	0.0	24.8	41.8	0.0	21.4	13.1	0.4	0.4	15.7	18.4	18.5
Incr Delay (d2), s/veh	1.2	0.0	9.5	5.6	0.0	1.3	8.1	6.6	6.5	2.3	5.9	5.8
Initial Q Delay(d3),s/veh	0.0	0.0	0.0	0.0	0.0	0.0	0.0	0.0	0.0	0.0	0.0	0.0
%ile BackOfQ(95%),veh/ln	5.0	0.0	19.4	3.9	0.0	11.4	2.4	3.3	3.4	1.8	17.2	17.6
Unsig. Movement Delay, s/veh												
LnGrp Delay(d),s/veh	33.8	0.0	34.3	47.4	0.0	22.7	21.2	7.1	7.0	18.0	24.3	24.3
LnGrp LOS	C	A	C	D	A	C	C	A	A	B	C	C
Approach Vol, veh/h		757			513			1442			1392	
Approach Delay, s/veh		34.2			26.9			7.7			24.0	
Approach LOS		C			C			A			C	
Timer - Assigned Phs		2		4		6		8				
Phs Duration (G+Y+Rc), s		49.0		41.0		49.0		41.0				
Change Period (Y+Rc), s		* 4.8		* 5.4		* 4.8		* 5.4				
Max Green Setting (Gmax), s		* 44		* 36		* 44		* 36				
Max Q Clear Time (g_c+I1), s		42.4		30.2		28.9		37.6				
Green Ext Time (p_c), s		1.5		2.3		9.0		0.0				

Intersection Summary

HCM 6th Ctrl Delay	20.5
HCM 6th LOS	C

Notes

* HCM 6th computational engine requires equal clearance times for the phases crossing the barrier.

HCM 6th Signalized Intersection Summary

2: Vine St & Lexington Ave

10/14/2022



Movement	EBL	EBT	EBR	WBL	WBT	WBR	NBL	NBT	NBR	SBL	SBT	SBR
Lane Configurations		↕			↕		↙	↕		↙	↕	
Traffic Volume (veh/h)	53	128	47	32	52	79	18	1208	42	34	1221	29
Future Volume (veh/h)	53	128	47	32	52	79	18	1208	42	34	1221	29
Initial Q (Qb), veh	0	0	0	0	0	0	0	0	0	0	0	0
Ped-Bike Adj(A_pbT)	1.00		1.00	1.00		1.00	1.00		1.00	1.00		1.00
Parking Bus, Adj	1.00	1.00	1.00	1.00	1.00	1.00	1.00	1.00	1.00	1.00	1.00	1.00
Work Zone On Approach		No			No			No			No	
Adj Sat Flow, veh/h/ln	1870	1870	1870	1870	1870	1870	1870	1870	1870	1870	1870	1870
Adj Flow Rate, veh/h	58	139	51	35	57	86	20	1313	46	37	1327	32
Peak Hour Factor	0.92	0.92	0.92	0.92	0.92	0.92	0.92	0.92	0.92	0.92	0.92	0.92
Percent Heavy Veh, %	2	2	2	2	2	2	2	2	2	2	2	2
Cap, veh/h	103	181	61	85	111	138	366	2501	88	297	2532	61
Arrive On Green	0.17	0.17	0.17	0.17	0.17	0.17	0.71	0.71	0.71	1.00	1.00	1.00
Sat Flow, veh/h	305	1032	346	211	634	790	401	3503	123	401	3546	85
Grp Volume(v), veh/h	248	0	0	178	0	0	20	665	694	37	664	695
Grp Sat Flow(s),veh/h/ln	1684	0	0	1635	0	0	401	1777	1848	401	1777	1855
Q Serve(g_s), s	3.9	0.0	0.0	0.0	0.0	0.0	1.4	15.4	15.5	2.3	0.0	0.0
Cycle Q Clear(g_c), s	12.7	0.0	0.0	8.8	0.0	0.0	1.4	15.4	15.5	17.8	0.0	0.0
Prop In Lane	0.23		0.21	0.20		0.48	1.00		0.07	1.00		0.05
Lane Grp Cap(c), veh/h	344	0	0	334	0	0	366	1269	1320	297	1269	1325
V/C Ratio(X)	0.72	0.00	0.00	0.53	0.00	0.00	0.05	0.52	0.53	0.12	0.52	0.52
Avail Cap(c_a), veh/h	521	0	0	505	0	0	366	1269	1320	297	1269	1325
HCM Platoon Ratio	1.00	1.00	1.00	1.00	1.00	1.00	1.00	1.00	1.00	2.00	2.00	2.00
Upstream Filter(I)	1.00	0.00	0.00	1.00	0.00	0.00	1.00	1.00	1.00	1.00	1.00	1.00
Uniform Delay (d), s/veh	35.7	0.0	0.0	34.2	0.0	0.0	3.9	5.9	5.9	2.1	0.0	0.0
Incr Delay (d2), s/veh	2.9	0.0	0.0	1.3	0.0	0.0	0.3	1.6	1.5	0.9	1.5	1.5
Initial Q Delay(d3),s/veh	0.0	0.0	0.0	0.0	0.0	0.0	0.0	0.0	0.0	0.0	0.0	0.0
%ile BackOfQ(95%),veh/ln	9.2	0.0	0.0	6.6	0.0	0.0	0.2	8.8	9.1	0.3	1.0	1.0
Unsig. Movement Delay, s/veh												
LnGrp Delay(d),s/veh	38.6	0.0	0.0	35.5	0.0	0.0	4.2	7.4	7.4	3.0	1.5	1.5
LnGrp LOS	D	A	A	D	A	A	A	A	A	A	A	A
Approach Vol, veh/h		248		178			1379			1396		
Approach Delay, s/veh		38.6		35.5			7.4			1.6		
Approach LOS		D		D			A			A		
Timer - Assigned Phs		2		4		6	8					
Phs Duration (G+Y+Rc), s		68.9		21.1		68.9	21.1					
Change Period (Y+Rc), s		4.6		* 5.4		4.6	* 5.4					
Max Green Setting (Gmax), s		54.4		* 26		54.4	* 26					
Max Q Clear Time (g_c+I1), s		17.5		14.7		19.8	10.8					
Green Ext Time (p_c), s		25.3		1.0		24.5	0.8					

Intersection Summary

HCM 6th Ctrl Delay	8.8
HCM 6th LOS	A

Notes

* HCM 6th computational engine requires equal clearance times for the phases crossing the barrier.

HCM 6th Signalized Intersection Summary

1: Vine St & Fountain Ave

10/14/2022



Movement	EBL	EBT	EBR	WBL	WBT	WBR	NBL	NBT	NBR	SBL	SBT	SBR
Lane Configurations	↖	↗		↖	↗		↖	↕		↖	↗	
Traffic Volume (veh/h)	101	291	46	96	452	49	47	1244	63	26	1566	114
Future Volume (veh/h)	101	291	46	96	452	49	47	1244	63	26	1566	114
Initial Q (Qb), veh	0	0	0	0	0	0	0	0	0	0	0	0
Ped-Bike Adj(A_pbT)	1.00		1.00	1.00		1.00	1.00		1.00	1.00		1.00
Parking Bus, Adj	1.00	1.00	1.00	1.00	1.00	1.00	1.00	1.00	1.00	1.00	1.00	1.00
Work Zone On Approach		No			No			No			No	
Adj Sat Flow, veh/h/ln	1870	1870	1870	1870	1870	1870	1870	1870	1870	1870	1870	1870
Adj Flow Rate, veh/h	110	316	50	104	491	53	51	1352	68	28	1702	124
Peak Hour Factor	0.92	0.92	0.92	0.92	0.92	0.92	0.92	0.92	0.92	0.92	0.92	0.92
Percent Heavy Veh, %	2	2	2	2	2	2	2	2	2	2	2	2
Cap, veh/h	148	553	88	271	583	63	93	1844	93	169	1800	130
Arrive On Green	0.35	0.35	0.35	0.35	0.35	0.35	0.54	0.54	0.54	0.54	0.54	0.54
Sat Flow, veh/h	862	1576	249	1016	1659	179	255	3443	173	378	3361	243
Grp Volume(v), veh/h	110	0	366	104	0	544	51	696	724	28	892	934
Grp Sat Flow(s),veh/h/ln	862	0	1825	1016	0	1838	255	1777	1839	378	1777	1827
Q Serve(g_s), s	7.1	0.0	14.6	8.3	0.0	24.5	4.5	26.9	27.1	5.5	42.1	43.7
Cycle Q Clear(g_c), s	31.6	0.0	14.6	23.0	0.0	24.5	48.2	26.9	27.1	32.6	42.1	43.7
Prop In Lane	1.00		0.14	1.00		0.10	1.00		0.09	1.00		0.13
Lane Grp Cap(c), veh/h	148	0	641	271	0	645	93	952	985	169	952	978
V/C Ratio(X)	0.75	0.00	0.57	0.38	0.00	0.84	0.55	0.73	0.73	0.17	0.94	0.95
Avail Cap(c_a), veh/h	148	0	641	271	0	645	93	952	985	169	952	978
HCM Platoon Ratio	1.00	1.00	1.00	1.00	1.00	1.00	1.00	1.00	1.00	1.00	1.00	1.00
Upstream Filter(I)	1.00	0.00	1.00	1.00	0.00	1.00	1.00	1.00	1.00	1.00	1.00	1.00
Uniform Delay (d), s/veh	42.8	0.0	23.7	33.0	0.0	26.9	44.4	16.0	16.0	28.5	19.5	19.9
Incr Delay (d2), s/veh	18.5	0.0	1.2	0.9	0.0	9.9	21.5	5.0	4.9	2.1	17.5	19.7
Initial Q Delay(d3),s/veh	0.0	0.0	0.0	0.0	0.0	0.0	0.0	0.0	0.0	0.0	0.0	0.0
%ile BackOfQ(95%),veh/ln	5.7	0.0	10.4	3.8	0.0	17.8	3.0	16.8	17.3	1.1	27.6	29.7
Unsig. Movement Delay, s/veh												
LnGrp Delay(d),s/veh	61.3	0.0	24.9	33.9	0.0	36.8	65.9	20.9	20.9	30.6	37.0	39.6
LnGrp LOS	E	A	C	C	A	D	E	C	C	C	D	D
Approach Vol, veh/h		476			648			1471			1854	
Approach Delay, s/veh		33.3			36.3			22.5			38.2	
Approach LOS		C			D			C			D	
Timer - Assigned Phs		2		4		6		8				
Phs Duration (G+Y+Rc), s		53.0		37.0		53.0		37.0				
Change Period (Y+Rc), s		* 4.8		* 5.4		* 4.8		* 5.4				
Max Green Setting (Gmax), s		* 48		* 32		* 48		* 32				
Max Q Clear Time (g_c+I1), s		50.2		33.6		45.7		26.5				
Green Ext Time (p_c), s		0.0		0.0		2.2		1.8				

Intersection Summary

HCM 6th Ctrl Delay	32.2
HCM 6th LOS	C

Notes

* HCM 6th computational engine requires equal clearance times for the phases crossing the barrier.

HCM 6th Signalized Intersection Summary

2: Vine St & Lexington Ave

10/14/2022



Movement	EBL	EBT	EBR	WBL	WBT	WBR	NBL	NBT	NBR	SBL	SBT	SBR
Lane Configurations		↕			↕		↙	↕		↙	↕	
Traffic Volume (veh/h)	20	37	39	29	79	30	56	1324	16	18	1587	56
Future Volume (veh/h)	20	37	39	29	79	30	56	1324	16	18	1587	56
Initial Q (Qb), veh	0	0	0	0	0	0	0	0	0	0	0	0
Ped-Bike Adj(A_pbT)	1.00		1.00	1.00		1.00	1.00		1.00	1.00		1.00
Parking Bus, Adj	1.00	1.00	1.00	1.00	1.00	1.00	1.00	1.00	1.00	1.00	1.00	1.00
Work Zone On Approach		No			No			No			No	
Adj Sat Flow, veh/h/ln	1870	1870	1870	1870	1870	1870	1870	1870	1870	1870	1870	1870
Adj Flow Rate, veh/h	22	40	42	32	86	33	61	1439	17	20	1725	61
Peak Hour Factor	0.92	0.92	0.92	0.92	0.92	0.92	0.92	0.92	0.92	0.92	0.92	0.92
Percent Heavy Veh, %	2	2	2	2	2	2	2	2	2	2	2	2
Cap, veh/h	75	90	79	78	123	43	286	2795	33	309	2720	96
Arrive On Green	0.11	0.11	0.11	0.11	0.11	0.11	0.78	0.78	0.78	1.00	1.00	1.00
Sat Flow, veh/h	238	802	704	264	1095	380	265	3597	42	365	3502	123
Grp Volume(v), veh/h	104	0	0	151	0	0	61	710	746	20	872	914
Grp Sat Flow(s),veh/h/ln	1744	0	0	1739	0	0	265	1777	1863	365	1777	1848
Q Serve(g_s), s	0.0	0.0	0.0	2.5	0.0	0.0	6.0	13.4	13.4	1.0	0.0	0.0
Cycle Q Clear(g_c), s	5.0	0.0	0.0	7.5	0.0	0.0	6.0	13.4	13.4	14.4	0.0	0.0
Prop In Lane	0.21		0.40	0.21		0.22	1.00		0.02	1.00		0.07
Lane Grp Cap(c), veh/h	244	0	0	243	0	0	286	1380	1447	309	1380	1436
V/C Ratio(X)	0.43	0.00	0.00	0.62	0.00	0.00	0.21	0.51	0.52	0.06	0.63	0.64
Avail Cap(c_a), veh/h	483	0	0	492	0	0	286	1380	1447	309	1380	1436
HCM Platoon Ratio	1.00	1.00	1.00	1.00	1.00	1.00	1.00	1.00	1.00	2.00	2.00	2.00
Upstream Filter(I)	1.00	0.00	0.00	1.00	0.00	0.00	1.00	1.00	1.00	1.00	1.00	1.00
Uniform Delay (d), s/veh	37.7	0.0	0.0	38.7	0.0	0.0	2.9	3.7	3.7	1.4	0.0	0.0
Incr Delay (d2), s/veh	1.2	0.0	0.0	2.6	0.0	0.0	1.7	1.4	1.3	0.4	2.2	2.2
Initial Q Delay(d3),s/veh	0.0	0.0	0.0	0.0	0.0	0.0	0.0	0.0	0.0	0.0	0.0	0.0
%ile BackOfQ(95%),veh/ln	0.0	0.0	0.0	6.1	0.0	0.0	0.6	6.7	7.0	0.1	1.5	1.6
Unsig. Movement Delay, s/veh												
LnGrp Delay(d),s/veh	38.9	0.0	0.0	41.3	0.0	0.0	4.6	5.1	5.0	1.8	2.2	2.2
LnGrp LOS	D	A	A	D	A	A	A	A	A	A	A	A
Approach Vol, veh/h		104		151			1517			1806		
Approach Delay, s/veh		38.9		41.3			5.1			2.2		
Approach LOS		D		D			A			A		
Timer - Assigned Phs		2		4			6			8		
Phs Duration (G+Y+Rc), s		74.5		15.5			74.5			15.5		
Change Period (Y+Rc), s		4.6		* 5.4			4.6			* 5.4		
Max Green Setting (Gmax), s		56.4		* 24			56.4			* 24		
Max Q Clear Time (g_c+I1), s		15.4		7.0			16.4			9.5		
Green Ext Time (p_c), s		31.0		0.4			34.5			0.6		

Intersection Summary

HCM 6th Ctrl Delay	6.1
HCM 6th LOS	A

Notes

* HCM 6th computational engine requires equal clearance times for the phases crossing the barrier.

HCM 6th Signalized Intersection Summary

1: Vine St & Fountain Ave

10/14/2022



Movement	EBL	EBT	EBR	WBL	WBT	WBR	NBL	NBT	NBR	SBL	SBT	SBR
Lane Configurations												
Traffic Volume (veh/h)	156	569	76	108	398	67	69	1461	74	55	1338	133
Future Volume (veh/h)	156	569	76	108	398	67	69	1461	74	55	1338	133
Initial Q (Qb), veh	0	0	0	0	0	0	0	0	0	0	0	0
Ped-Bike Adj(A_pbT)	1.00		1.00	1.00		1.00	1.00		1.00	1.00		1.00
Parking Bus, Adj	1.00	1.00	1.00	1.00	1.00	1.00	1.00	1.00	1.00	1.00	1.00	1.00
Work Zone On Approach		No			No			No			No	
Adj Sat Flow, veh/h/ln	1870	1870	1870	1870	1870	1870	1870	1870	1870	1870	1870	1870
Adj Flow Rate, veh/h	170	618	83	117	433	73	75	1588	80	60	1454	145
Peak Hour Factor	0.92	0.92	0.92	0.92	0.92	0.92	0.92	0.92	0.92	0.92	0.92	0.92
Percent Heavy Veh, %	2	2	2	2	2	2	2	2	2	2	2	2
Cap, veh/h	226	639	86	95	617	104	105	1691	85	193	1604	159
Arrive On Green	0.40	0.40	0.40	0.40	0.40	0.40	0.98	0.98	0.98	0.49	0.49	0.49
Sat Flow, veh/h	893	1614	217	745	1560	263	318	3443	173	298	3266	323
Grp Volume(v), veh/h	170	0	701	117	0	506	75	816	852	60	786	813
Grp Sat Flow(s),veh/h/ln	893	0	1831	745	0	1823	318	1777	1839	298	1777	1812
Q Serve(g_s), s	14.7	0.0	33.7	1.9	0.0	20.9	7.0	9.0	10.1	14.1	36.4	37.2
Cycle Q Clear(g_c), s	35.6	0.0	33.7	35.6	0.0	20.9	44.2	9.0	10.1	24.2	36.4	37.2
Prop In Lane	1.00		0.12	1.00		0.14	1.00		0.09	1.00		0.18
Lane Grp Cap(c), veh/h	226	0	724	95	0	721	105	873	903	193	873	890
V/C Ratio(X)	0.75	0.00	0.97	1.23	0.00	0.70	0.72	0.94	0.94	0.31	0.90	0.91
Avail Cap(c_a), veh/h	226	0	724	95	0	721	105	873	903	193	873	890
HCM Platoon Ratio	1.00	1.00	1.00	1.00	1.00	1.00	2.00	2.00	2.00	1.00	1.00	1.00
Upstream Filter(I)	1.00	0.00	1.00	1.00	0.00	1.00	1.00	1.00	1.00	1.00	1.00	1.00
Uniform Delay (d), s/veh	38.7	0.0	26.6	44.8	0.0	22.8	21.8	0.5	0.5	21.7	20.9	21.1
Incr Delay (d2), s/veh	13.3	0.0	25.6	164.9	0.0	3.1	34.3	18.3	19.0	4.2	14.3	15.3
Initial Q Delay(d3),s/veh	0.0	0.0	0.0	0.0	0.0	0.0	0.0	0.0	0.0	0.0	0.0	0.0
%ile BackOfQ(95%),veh/ln	8.1	0.0	26.2	11.7	0.0	14.1	4.4	8.3	8.7	2.1	24.2	25.2
Unsig. Movement Delay, s/veh												
LnGrp Delay(d),s/veh	52.0	0.0	52.2	209.7	0.0	25.8	56.1	18.8	19.5	25.9	35.2	36.4
LnGrp LOS	D	A	D	F	A	C	E	B	B	C	D	D
Approach Vol, veh/h		871			623			1743			1659	
Approach Delay, s/veh		52.2			60.3			20.7			35.4	
Approach LOS		D			E			C			D	
Timer - Assigned Phs		2		4		6		8				
Phs Duration (G+Y+Rc), s		49.0		41.0		49.0		41.0				
Change Period (Y+Rc), s		* 4.8		* 5.4		* 4.8		* 5.4				
Max Green Setting (Gmax), s		* 44		* 36		* 44		* 36				
Max Q Clear Time (g_c+I1), s		46.2		37.6		39.2		37.6				
Green Ext Time (p_c), s		0.0		0.0		4.1		0.0				

Intersection Summary

HCM 6th Ctrl Delay	36.3
HCM 6th LOS	D

Notes

* HCM 6th computational engine requires equal clearance times for the phases crossing the barrier.

HCM 6th Signalized Intersection Summary

2: Vine St & Lexington Ave

10/14/2022



Movement	EBL	EBT	EBR	WBL	WBT	WBR	NBL	NBT	NBR	SBL	SBT	SBR
Lane Configurations		↕			↕		↙	↕		↙	↕	
Traffic Volume (veh/h)	44	135	49	22	49	56	19	1507	39	28	1511	30
Future Volume (veh/h)	44	135	49	22	49	56	19	1507	39	28	1511	30
Initial Q (Qb), veh	0	0	0	0	0	0	0	0	0	0	0	0
Ped-Bike Adj(A_pbT)	1.00		1.00	1.00		1.00	1.00		1.00	1.00		1.00
Parking Bus, Adj	1.00	1.00	1.00	1.00	1.00	1.00	1.00	1.00	1.00	1.00	1.00	1.00
Work Zone On Approach		No			No			No			No	
Adj Sat Flow, veh/h/ln	1870	1870	1870	1870	1870	1870	1870	1870	1870	1870	1870	1870
Adj Flow Rate, veh/h	48	147	53	24	53	61	21	1638	42	30	1642	33
Peak Hour Factor	0.92	0.92	0.92	0.92	0.92	0.92	0.92	0.92	0.92	0.92	0.92	0.92
Percent Heavy Veh, %	2	2	2	2	2	2	2	2	2	2	2	2
Cap, veh/h	90	190	63	76	132	128	292	2540	65	219	2557	51
Arrive On Green	0.17	0.17	0.17	0.17	0.17	0.17	0.72	0.72	0.72	1.00	1.00	1.00
Sat Flow, veh/h	247	1111	369	171	771	747	296	3540	91	294	3563	71
Grp Volume(v), veh/h	248	0	0	138	0	0	21	820	860	30	817	858
Grp Sat Flow(s),veh/h/ln	1727	0	0	1690	0	0	296	1777	1854	294	1777	1857
Q Serve(g_s), s	5.9	0.0	0.0	0.0	0.0	0.0	1.9	21.8	22.0	3.6	0.0	0.0
Cycle Q Clear(g_c), s	12.4	0.0	0.0	6.5	0.0	0.0	1.9	21.8	22.0	25.6	0.0	0.0
Prop In Lane	0.19		0.21	0.17		0.44	1.00		0.05	1.00		0.04
Lane Grp Cap(c), veh/h	344	0	0	337	0	0	292	1275	1330	219	1275	1333
V/C Ratio(X)	0.72	0.00	0.00	0.41	0.00	0.00	0.07	0.64	0.65	0.14	0.64	0.64
Avail Cap(c_a), veh/h	531	0	0	516	0	0	292	1275	1330	219	1275	1333
HCM Platoon Ratio	1.00	1.00	1.00	1.00	1.00	1.00	1.00	1.00	1.00	2.00	2.00	2.00
Upstream Filter(I)	1.00	0.00	0.00	1.00	0.00	0.00	1.00	1.00	1.00	1.00	1.00	1.00
Uniform Delay (d), s/veh	35.9	0.0	0.0	33.6	0.0	0.0	3.9	6.7	6.7	4.4	0.0	0.0
Incr Delay (d2), s/veh	2.9	0.0	0.0	0.8	0.0	0.0	0.5	2.5	2.4	1.3	2.5	2.4
Initial Q Delay(d3),s/veh	0.0	0.0	0.0	0.0	0.0	0.0	0.0	0.0	0.0	0.0	0.0	0.0
%ile BackOfQ(95%),veh/ln	9.2	0.0	0.0	4.9	0.0	0.0	0.2	11.7	12.1	0.4	1.6	1.6
Unsig. Movement Delay, s/veh												
LnGrp Delay(d),s/veh	38.8	0.0	0.0	34.4	0.0	0.0	4.3	9.2	9.1	5.7	2.5	2.4
LnGrp LOS	D	A	A	C	A	A	A	A	A	A	A	A
Approach Vol, veh/h		248			138			1701			1705	
Approach Delay, s/veh		38.8			34.4			9.1			2.5	
Approach LOS		D			C			A			A	
Timer - Assigned Phs		2		4		6		8				
Phs Duration (G+Y+Rc), s		69.2		20.8		69.2		20.8				
Change Period (Y+Rc), s		4.6		* 5.4		4.6		* 5.4				
Max Green Setting (Gmax), s		54.4		* 26		54.4		* 26				
Max Q Clear Time (g_c+I1), s		24.0		14.4		27.6		8.5				
Green Ext Time (p_c), s		26.1		1.1		23.4		0.7				

Intersection Summary

HCM 6th Ctrl Delay	9.0
HCM 6th LOS	A

Notes

* HCM 6th computational engine requires equal clearance times for the phases crossing the barrier.

HCM 6th Signalized Intersection Summary

1: Vine St & Fountain Ave

10/14/2022



Movement	EBL	EBT	EBR	WBL	WBT	WBR	NBL	NBT	NBR	SBL	SBT	SBR
Lane Configurations	↖	↗		↖	↗		↖	↕		↖	↗	
Traffic Volume (veh/h)	101	291	47	96	452	49	53	1260	87	35	1568	114
Future Volume (veh/h)	101	291	47	96	452	49	53	1260	87	35	1568	114
Initial Q (Qb), veh	0	0	0	0	0	0	0	0	0	0	0	0
Ped-Bike Adj(A_pbT)	1.00		1.00	1.00		1.00	1.00		1.00	1.00		1.00
Parking Bus, Adj	1.00	1.00	1.00	1.00	1.00	1.00	1.00	1.00	1.00	1.00	1.00	1.00
Work Zone On Approach		No			No			No			No	
Adj Sat Flow, veh/h/ln	1870	1870	1870	1870	1870	1870	1870	1870	1870	1870	1870	1870
Adj Flow Rate, veh/h	110	316	51	104	491	53	58	1370	95	38	1704	124
Peak Hour Factor	0.92	0.92	0.92	0.92	0.92	0.92	0.92	0.92	0.92	0.92	0.92	0.92
Percent Heavy Veh, %	2	2	2	2	2	2	2	2	2	2	2	2
Cap, veh/h	148	552	89	271	583	63	92	1806	125	158	1800	130
Arrive On Green	0.35	0.35	0.35	0.35	0.35	0.35	0.54	0.54	0.54	0.54	0.54	0.54
Sat Flow, veh/h	862	1571	254	1015	1659	179	255	3372	233	362	3361	242
Grp Volume(v), veh/h	110	0	367	104	0	544	58	720	745	38	893	935
Grp Sat Flow(s),veh/h/ln	862	0	1825	1015	0	1838	255	1777	1828	362	1777	1827
Q Serve(g_s), s	7.1	0.0	14.7	8.3	0.0	24.5	4.4	28.5	28.7	8.3	42.2	43.8
Cycle Q Clear(g_c), s	31.6	0.0	14.7	23.0	0.0	24.5	48.2	28.5	28.7	37.0	42.2	43.8
Prop In Lane	1.00		0.14	1.00		0.10	1.00		0.13	1.00		0.13
Lane Grp Cap(c), veh/h	148	0	641	271	0	645	92	952	979	158	952	978
V/C Ratio(X)	0.75	0.00	0.57	0.38	0.00	0.84	0.63	0.76	0.76	0.24	0.94	0.96
Avail Cap(c_a), veh/h	148	0	641	271	0	645	92	952	979	158	952	978
HCM Platoon Ratio	1.00	1.00	1.00	1.00	1.00	1.00	1.00	1.00	1.00	1.00	1.00	1.00
Upstream Filter(I)	1.00	0.00	1.00	1.00	0.00	1.00	1.00	1.00	1.00	1.00	1.00	1.00
Uniform Delay (d), s/veh	42.8	0.0	23.7	33.1	0.0	26.9	44.5	16.3	16.4	30.9	19.5	19.9
Incr Delay (d2), s/veh	18.5	0.0	1.2	0.9	0.0	9.9	28.1	5.6	5.6	3.6	17.6	19.9
Initial Q Delay(d3),s/veh	0.0	0.0	0.0	0.0	0.0	0.0	0.0	0.0	0.0	0.0	0.0	0.0
%ile BackOfQ(95%),veh/ln	5.7	0.0	10.5	3.8	0.0	17.8	3.6	17.7	18.3	1.6	27.7	29.8
Unsig. Movement Delay, s/veh												
LnGrp Delay(d),s/veh	61.3	0.0	25.0	34.0	0.0	36.8	72.7	21.9	21.9	34.5	37.1	39.8
LnGrp LOS	E	A	C	C	A	D	E	C	C	C	D	D
Approach Vol, veh/h		477			648			1523			1866	
Approach Delay, s/veh		33.3			36.4			23.9			38.4	
Approach LOS		C			D			C			D	
Timer - Assigned Phs		2		4		6		8				
Phs Duration (G+Y+Rc), s		53.0		37.0		53.0		37.0				
Change Period (Y+Rc), s		* 4.8		* 5.4		* 4.8		* 5.4				
Max Green Setting (Gmax), s		* 48		* 32		* 48		* 32				
Max Q Clear Time (g_c+I1), s		50.2		33.6		45.8		26.5				
Green Ext Time (p_c), s		0.0		0.0		2.1		1.8				

Intersection Summary

HCM 6th Ctrl Delay	32.7
HCM 6th LOS	C

Notes

* HCM 6th computational engine requires equal clearance times for the phases crossing the barrier.

HCM 6th Signalized Intersection Summary

2: Vine St & Lexington Ave

10/14/2022



Movement	EBL	EBT	EBR	WBL	WBT	WBR	NBL	NBT	NBR	SBL	SBT	SBR
Lane Configurations		↕			↕		↙	↕		↙	↕	
Traffic Volume (veh/h)	29	38	39	45	89	57	56	1333	18	21	1587	56
Future Volume (veh/h)	29	38	39	45	89	57	56	1333	18	21	1587	56
Initial Q (Qb), veh	0	0	0	0	0	0	0	0	0	0	0	0
Ped-Bike Adj(A_pbT)	1.00		1.00	1.00		1.00	1.00		1.00	1.00		1.00
Parking Bus, Adj	1.00	1.00	1.00	1.00	1.00	1.00	1.00	1.00	1.00	1.00	1.00	1.00
Work Zone On Approach		No			No			No			No	
Adj Sat Flow, veh/h/ln	1870	1870	1870	1870	1870	1870	1870	1870	1870	1870	1870	1870
Adj Flow Rate, veh/h	32	41	42	49	97	62	61	1449	20	23	1725	61
Peak Hour Factor	0.92	0.92	0.92	0.92	0.92	0.92	0.92	0.92	0.92	0.92	0.92	0.92
Percent Heavy Veh, %	2	2	2	2	2	2	2	2	2	2	2	2
Cap, veh/h	96	111	89	95	132	75	276	2656	37	283	2592	91
Arrive On Green	0.15	0.15	0.15	0.15	0.15	0.15	0.74	0.74	0.74	1.00	1.00	1.00
Sat Flow, veh/h	299	744	600	305	887	506	265	3589	50	361	3502	123
Grp Volume(v), veh/h	115	0	0	208	0	0	61	717	752	23	872	914
Grp Sat Flow(s),veh/h/ln	1644	0	0	1698	0	0	265	1777	1861	361	1777	1848
Q Serve(g_s), s	0.0	0.0	0.0	5.1	0.0	0.0	7.0	15.8	15.9	1.5	0.0	0.0
Cycle Q Clear(g_c), s	5.5	0.0	0.0	10.6	0.0	0.0	7.0	15.8	15.9	17.3	0.0	0.0
Prop In Lane	0.28		0.37	0.24		0.30	1.00		0.03	1.00		0.07
Lane Grp Cap(c), veh/h	296	0	0	302	0	0	276	1315	1378	283	1315	1368
V/C Ratio(X)	0.39	0.00	0.00	0.69	0.00	0.00	0.22	0.55	0.55	0.08	0.66	0.67
Avail Cap(c_a), veh/h	471	0	0	486	0	0	276	1315	1378	283	1315	1368
HCM Platoon Ratio	1.00	1.00	1.00	1.00	1.00	1.00	1.00	1.00	1.00	2.00	2.00	2.00
Upstream Filter(I)	1.00	0.00	0.00	1.00	0.00	0.00	1.00	1.00	1.00	1.00	1.00	1.00
Uniform Delay (d), s/veh	34.9	0.0	0.0	37.0	0.0	0.0	3.9	5.1	5.1	2.1	0.0	0.0
Incr Delay (d2), s/veh	0.8	0.0	0.0	2.8	0.0	0.0	1.8	1.6	1.6	0.6	2.6	2.6
Initial Q Delay(d3),s/veh	0.0	0.0	0.0	0.0	0.0	0.0	0.0	0.0	0.0	0.0	0.0	0.0
%ile BackOfQ(95%),veh/ln	4.2	0.0	0.0	8.1	0.0	0.0	0.8	8.6	8.9	0.2	1.7	1.8
Unsig. Movement Delay, s/veh												
LnGrp Delay(d),s/veh	35.7	0.0	0.0	39.8	0.0	0.0	5.8	6.7	6.7	2.6	2.6	2.6
LnGrp LOS	D	A	A	D	A	A	A	A	A	A	A	A
Approach Vol, veh/h		115			208			1530			1809	
Approach Delay, s/veh		35.7			39.8			6.7			2.6	
Approach LOS		D			D			A			A	
Timer - Assigned Phs		2		4		6		8				
Phs Duration (G+Y+Rc), s		71.2		18.8		71.2		18.8				
Change Period (Y+Rc), s		4.6		* 5.4		4.6		* 5.4				
Max Green Setting (Gmax), s		56.4		* 24		56.4		* 24				
Max Q Clear Time (g_c+I1), s		17.9		7.5		19.3		12.6				
Green Ext Time (p_c), s		29.8		0.5		32.3		0.8				

Intersection Summary

HCM 6th Ctrl Delay	7.5
HCM 6th LOS	A

Notes

* HCM 6th computational engine requires equal clearance times for the phases crossing the barrier.

HCM 6th TWSC
 3: Vine St & Commercial Driveway

10/14/2022

Intersection						
Int Delay, s/veh	0.2					
Movement	WBL	WBR	NBT	NBR	SBL	SBT
Lane Configurations		↗	↗↗			↗↗
Traffic Vol, veh/h	0	37	1383	35	0	1664
Future Vol, veh/h	0	37	1383	35	0	1664
Conflicting Peds, #/hr	0	0	0	0	0	0
Sign Control	Stop	Stop	Free	Free	Free	Free
RT Channelized	-	None	-	None	-	None
Storage Length	-	0	-	-	-	-
Veh in Median Storage, #	0	-	0	-	-	0
Grade, %	0	-	0	-	-	0
Peak Hour Factor	92	92	92	92	92	92
Heavy Vehicles, %	2	2	2	2	2	2
Mvmt Flow	0	40	1503	38	0	1809

Major/Minor	Minor1	Major1	Major2
Conflicting Flow All	-	771	0
Stage 1	-	-	-
Stage 2	-	-	-
Critical Hdwy	-	6.94	-
Critical Hdwy Stg 1	-	-	-
Critical Hdwy Stg 2	-	-	-
Follow-up Hdwy	-	3.32	-
Pot Cap-1 Maneuver	0	343	-
Stage 1	0	-	-
Stage 2	0	-	-
Platoon blocked, %			
Mov Cap-1 Maneuver	-	343	-
Mov Cap-2 Maneuver	-	-	-
Stage 1	-	-	-
Stage 2	-	-	-

Approach	WB	NB	SB
HCM Control Delay, s	16.9	0	0
HCM LOS	C		

Minor Lane/Major Mvmt	NBT	NBRWBLn1	SBT
Capacity (veh/h)	-	-	343
HCM Lane V/C Ratio	-	-	0.117
HCM Control Delay (s)	-	-	16.9
HCM Lane LOS	-	-	C
HCM 95th %tile Q(veh)	-	-	0.4

HCM 6th TWSC
4: Lexington Ave & Residential Driveway

10/14/2022

Intersection						
Int Delay, s/veh	1.1					
Movement	EBL	EBT	WBT	WBR	SBL	SBR
Lane Configurations		↔	↔		↔	
Traffic Vol, veh/h	7	70	170	2	7	20
Future Vol, veh/h	7	70	170	2	7	20
Conflicting Peds, #/hr	0	0	0	0	0	0
Sign Control	Free	Free	Free	Free	Stop	Stop
RT Channelized	-	None	-	None	-	None
Storage Length	-	-	-	-	0	-
Veh in Median Storage, #	-	0	0	-	0	-
Grade, %	-	0	0	-	0	-
Peak Hour Factor	92	92	92	92	92	92
Heavy Vehicles, %	2	2	2	2	2	2
Mvmt Flow	8	76	185	2	8	22

Major/Minor	Major1	Major2	Minor2		
Conflicting Flow All	187	0	-	0	278 186
Stage 1	-	-	-	-	186 -
Stage 2	-	-	-	-	92 -
Critical Hdwy	4.12	-	-	-	6.42 6.22
Critical Hdwy Stg 1	-	-	-	-	5.42 -
Critical Hdwy Stg 2	-	-	-	-	5.42 -
Follow-up Hdwy	2.218	-	-	-	3.518 3.318
Pot Cap-1 Maneuver	1387	-	-	-	712 856
Stage 1	-	-	-	-	846 -
Stage 2	-	-	-	-	932 -
Platoon blocked, %		-	-	-	
Mov Cap-1 Maneuver	1387	-	-	-	708 856
Mov Cap-2 Maneuver	-	-	-	-	708 -
Stage 1	-	-	-	-	841 -
Stage 2	-	-	-	-	932 -

Approach	EB	WB	SB
HCM Control Delay, s	0.7	0	9.6
HCM LOS			A

Minor Lane/Major Mvmt	EBL	EBT	WBT	WBR	SBLn1
Capacity (veh/h)	1387	-	-	-	812
HCM Lane V/C Ratio	0.005	-	-	-	0.036
HCM Control Delay (s)	7.6	0	-	-	9.6
HCM Lane LOS	A	A	-	-	A
HCM 95th %tile Q(veh)	0	-	-	-	0.1

HCM 6th Signalized Intersection Summary

1: Vine St & Fountain Ave

10/14/2022



Movement	EBL	EBT	EBR	WBL	WBT	WBR	NBL	NBT	NBR	SBL	SBT	SBR
Lane Configurations												
Traffic Volume (veh/h)	156	569	78	108	398	67	73	1472	92	66	1343	133
Future Volume (veh/h)	156	569	78	108	398	67	73	1472	92	66	1343	133
Initial Q (Qb), veh	0	0	0	0	0	0	0	0	0	0	0	0
Ped-Bike Adj(A_pbT)	1.00		1.00	1.00		1.00	1.00		1.00	1.00		1.00
Parking Bus, Adj	1.00	1.00	1.00	1.00	1.00	1.00	1.00	1.00	1.00	1.00	1.00	1.00
Work Zone On Approach		No			No			No			No	
Adj Sat Flow, veh/h/ln	1870	1870	1870	1870	1870	1870	1870	1870	1870	1870	1870	1870
Adj Flow Rate, veh/h	170	618	85	117	433	73	79	1600	100	72	1460	145
Peak Hour Factor	0.92	0.92	0.92	0.92	0.92	0.92	0.92	0.92	0.92	0.92	0.92	0.92
Percent Heavy Veh, %	2	2	2	2	2	2	2	2	2	2	2	2
Cap, veh/h	226	637	88	94	617	104	104	1669	104	176	1604	158
Arrive On Green	0.40	0.40	0.40	0.40	0.40	0.40	0.98	0.98	0.98	0.49	0.49	0.49
Sat Flow, veh/h	893	1609	221	744	1560	263	316	3398	211	288	3267	322
Grp Volume(v), veh/h	170	0	703	117	0	506	79	832	868	72	789	816
Grp Sat Flow(s),veh/h/ln	893	0	1831	744	0	1823	316	1777	1832	288	1777	1812
Q Serve(g_s), s	14.7	0.0	33.9	1.7	0.0	20.9	6.7	11.8	14.4	20.0	36.6	37.5
Cycle Q Clear(g_c), s	35.6	0.0	33.9	35.6	0.0	20.9	44.2	11.8	14.4	34.4	36.6	37.5
Prop In Lane	1.00		0.12	1.00		0.14	1.00		0.12	1.00		0.18
Lane Grp Cap(c), veh/h	226	0	724	94	0	721	104	873	900	176	873	890
V/C Ratio(X)	0.75	0.00	0.97	1.25	0.00	0.70	0.76	0.95	0.96	0.41	0.90	0.92
Avail Cap(c_a), veh/h	226	0	724	94	0	721	104	873	900	176	873	890
HCM Platoon Ratio	1.00	1.00	1.00	1.00	1.00	1.00	2.00	2.00	2.00	1.00	1.00	1.00
Upstream Filter(I)	1.00	0.00	1.00	1.00	0.00	1.00	1.00	1.00	1.00	1.00	1.00	1.00
Uniform Delay (d), s/veh	38.7	0.0	26.7	44.9	0.0	22.8	21.9	0.5	0.5	26.8	21.0	21.2
Incr Delay (d2), s/veh	13.3	0.0	26.3	172.8	0.0	3.1	40.5	21.1	22.5	6.9	14.6	15.7
Initial Q Delay(d3),s/veh	0.0	0.0	0.0	0.0	0.0	0.0	0.0	0.0	0.0	0.0	0.0	0.0
%ile BackOfQ(95%),veh/ln	8.1	0.0	26.4	11.8	0.0	14.1	4.8	9.2	9.9	3.0	24.3	25.5
Unsig. Movement Delay, s/veh												
LnGrp Delay(d),s/veh	52.0	0.0	53.0	217.7	0.0	25.8	62.4	21.6	23.1	33.8	35.6	36.9
LnGrp LOS	D	A	D	F	A	C	E	C	C	C	D	D
Approach Vol, veh/h		873			623			1779			1677	
Approach Delay, s/veh		52.8			61.9			24.1			36.1	
Approach LOS		D			E			C			D	
Timer - Assigned Phs		2		4		6		8				
Phs Duration (G+Y+Rc), s		49.0		41.0		49.0		41.0				
Change Period (Y+Rc), s		* 4.8		* 5.4		* 4.8		* 5.4				
Max Green Setting (Gmax), s		* 44		* 36		* 44		* 36				
Max Q Clear Time (g_c+I1), s		46.2		37.6		39.5		37.6				
Green Ext Time (p_c), s		0.0		0.0		4.0		0.0				

Intersection Summary

HCM 6th Ctrl Delay	38.0
HCM 6th LOS	D

Notes

* HCM 6th computational engine requires equal clearance times for the phases crossing the barrier.

HCM 6th Signalized Intersection Summary

2: Vine St & Lexington Ave

10/14/2022



Movement	EBL	EBT	EBR	WBL	WBT	WBR	NBL	NBT	NBR	SBL	SBT	SBR
Lane Configurations		↕			↕		↙	↕		↙	↕	
Traffic Volume (veh/h)	55	138	49	33	55	82	19	1518	44	35	1511	30
Future Volume (veh/h)	55	138	49	33	55	82	19	1518	44	35	1511	30
Initial Q (Qb), veh	0	0	0	0	0	0	0	0	0	0	0	0
Ped-Bike Adj(A_pbT)	1.00		1.00	1.00		1.00	1.00		1.00	1.00		1.00
Parking Bus, Adj	1.00	1.00	1.00	1.00	1.00	1.00	1.00	1.00	1.00	1.00	1.00	1.00
Work Zone On Approach		No			No			No			No	
Adj Sat Flow, veh/h/ln	1870	1870	1870	1870	1870	1870	1870	1870	1870	1870	1870	1870
Adj Flow Rate, veh/h	60	150	53	36	60	89	21	1650	48	38	1642	33
Peak Hour Factor	0.92	0.92	0.92	0.92	0.92	0.92	0.92	0.92	0.92	0.92	0.92	0.92
Percent Heavy Veh, %	2	2	2	2	2	2	2	2	2	2	2	2
Cap, veh/h	104	192	62	86	117	144	288	2485	72	208	2511	50
Arrive On Green	0.18	0.18	0.18	0.18	0.18	0.18	0.70	0.70	0.70	1.00	1.00	1.00
Sat Flow, veh/h	297	1045	339	207	636	781	296	3526	102	289	3563	71
Grp Volume(v), veh/h	263	0	0	185	0	0	21	829	869	38	817	858
Grp Sat Flow(s),veh/h/ln	1681	0	0	1623	0	0	296	1777	1852	289	1777	1857
Q Serve(g_s), s	4.3	0.0	0.0	0.0	0.0	0.0	2.0	23.2	23.5	5.4	0.0	0.0
Cycle Q Clear(g_c), s	13.5	0.0	0.0	9.2	0.0	0.0	2.0	23.2	23.5	28.9	0.0	0.0
Prop In Lane	0.23		0.20	0.19		0.48	1.00		0.06	1.00		0.04
Lane Grp Cap(c), veh/h	359	0	0	347	0	0	288	1252	1305	208	1252	1309
V/C Ratio(X)	0.73	0.00	0.00	0.53	0.00	0.00	0.07	0.66	0.67	0.18	0.65	0.66
Avail Cap(c_a), veh/h	521	0	0	503	0	0	288	1252	1305	208	1252	1309
HCM Platoon Ratio	1.00	1.00	1.00	1.00	1.00	1.00	1.00	1.00	1.00	2.00	2.00	2.00
Upstream Filter(I)	1.00	0.00	0.00	1.00	0.00	0.00	1.00	1.00	1.00	1.00	1.00	1.00
Uniform Delay (d), s/veh	35.3	0.0	0.0	33.6	0.0	0.0	4.2	7.4	7.4	5.3	0.0	0.0
Incr Delay (d2), s/veh	3.0	0.0	0.0	1.3	0.0	0.0	0.5	2.8	2.7	1.9	2.7	2.6
Initial Q Delay(d3),s/veh	0.0	0.0	0.0	0.0	0.0	0.0	0.0	0.0	0.0	0.0	0.0	0.0
%ile BackOfQ(95%),veh/ln	9.7	0.0	0.0	6.8	0.0	0.0	0.3	12.6	13.1	0.6	1.7	1.7
Unsig. Movement Delay, s/veh												
LnGrp Delay(d),s/veh	38.3	0.0	0.0	34.9	0.0	0.0	4.7	10.1	10.1	7.3	2.7	2.6
LnGrp LOS	D	A	A	C	A	A	A	B	B	A	A	A
Approach Vol, veh/h		263		185				1719			1713	
Approach Delay, s/veh		38.3		34.9				10.0			2.7	
Approach LOS		D		C				B			A	
Timer - Assigned Phs		2		4			6	8				
Phs Duration (G+Y+Rc), s		68.0		22.0			68.0	22.0				
Change Period (Y+Rc), s		4.6		* 5.4			4.6	* 5.4				
Max Green Setting (Gmax), s		54.4		* 26			54.4	* 26				
Max Q Clear Time (g_c+I1), s		25.5		15.5			30.9	11.2				
Green Ext Time (p_c), s		25.1		1.1			20.9	0.9				

Intersection Summary

HCM 6th Ctrl Delay	9.9
HCM 6th LOS	A

Notes

* HCM 6th computational engine requires equal clearance times for the phases crossing the barrier.

HCM 6th TWSC
 3: Vine St & Commercial Driveway

10/14/2022

Intersection						
Int Delay, s/veh	0.2					
Movement	WBL	WBR	NBT	NBR	SBL	SBT
Lane Configurations		↗	↕			↕
Traffic Vol, veh/h	0	27	1612	42	0	1577
Future Vol, veh/h	0	27	1612	42	0	1577
Conflicting Peds, #/hr	0	0	0	0	0	0
Sign Control	Stop	Stop	Free	Free	Free	Free
RT Channelized	-	None	-	None	-	None
Storage Length	-	0	-	-	-	-
Veh in Median Storage, #	0	-	0	-	-	0
Grade, %	0	-	0	-	-	0
Peak Hour Factor	92	92	92	92	92	92
Heavy Vehicles, %	2	2	2	2	2	2
Mvmt Flow	0	29	1752	46	0	1714

Major/Minor	Minor1	Major1	Major2		
Conflicting Flow All	-	899	0	0	-
Stage 1	-	-	-	-	-
Stage 2	-	-	-	-	-
Critical Hdwy	-	6.94	-	-	-
Critical Hdwy Stg 1	-	-	-	-	-
Critical Hdwy Stg 2	-	-	-	-	-
Follow-up Hdwy	-	3.32	-	-	-
Pot Cap-1 Maneuver	0	282	-	-	0
Stage 1	0	-	-	-	0
Stage 2	0	-	-	-	0
Platoon blocked, %			-	-	-
Mov Cap-1 Maneuver	-	282	-	-	-
Mov Cap-2 Maneuver	-	-	-	-	-
Stage 1	-	-	-	-	-
Stage 2	-	-	-	-	-

Approach	WB	NB	SB
HCM Control Delay, s	19.2	0	0
HCM LOS	C		

Minor Lane/Major Mvmt	NBT	NBRWBLn1	SBT
Capacity (veh/h)	-	-	282
HCM Lane V/C Ratio	-	-	0.104
HCM Control Delay (s)	-	-	19.2
HCM Lane LOS	-	-	C
HCM 95th %tile Q(veh)	-	-	0.3

HCM 6th TWSC
4: Lexington Ave & Residential Driveway

10/14/2022

Intersection						
Int Delay, s/veh	0.7					
Movement	EBL	EBT	WBT	WBR	SBL	SBR
Lane Configurations		↕	↕		↕	
Traffic Vol, veh/h	16	203	159	5	4	11
Future Vol, veh/h	16	203	159	5	4	11
Conflicting Peds, #/hr	0	0	0	0	0	0
Sign Control	Free	Free	Free	Free	Stop	Stop
RT Channelized	-	None	-	None	-	None
Storage Length	-	-	-	-	0	-
Veh in Median Storage, #	-	0	0	-	0	-
Grade, %	-	0	0	-	0	-
Peak Hour Factor	92	92	92	92	92	92
Heavy Vehicles, %	2	2	2	2	2	2
Mvmt Flow	17	221	173	5	4	12

Major/Minor	Major1	Major2	Minor2		
Conflicting Flow All	178	0	-	0	431
Stage 1	-	-	-	-	176
Stage 2	-	-	-	-	255
Critical Hdwy	4.12	-	-	-	6.42
Critical Hdwy Stg 1	-	-	-	-	5.42
Critical Hdwy Stg 2	-	-	-	-	5.42
Follow-up Hdwy	2.218	-	-	-	3.518
Pot Cap-1 Maneuver	1398	-	-	-	581
Stage 1	-	-	-	-	855
Stage 2	-	-	-	-	788
Platoon blocked, %		-	-	-	
Mov Cap-1 Maneuver	1398	-	-	-	573
Mov Cap-2 Maneuver	-	-	-	-	573
Stage 1	-	-	-	-	843
Stage 2	-	-	-	-	788

Approach	EB	WB	SB
HCM Control Delay, s	0.6	0	9.8
HCM LOS			A

Minor Lane/Major Mvmt	EBL	EBT	WBT	WBR	SBLn1
Capacity (veh/h)	1398	-	-	-	763
HCM Lane V/C Ratio	0.012	-	-	-	0.021
HCM Control Delay (s)	7.6	0	-	-	9.8
HCM Lane LOS	A	A	-	-	A
HCM 95th %tile Q(veh)	0	-	-	-	0.1

CITY OF LOS ANGELES
INTER-DEPARTMENTAL CORRESPONDENCE

1200 N Vine St
DOT Case No. CEN22-53727

Date: December 19, 2022

To: Milena Zasadzien, Senior City Planner
Department of City Planning

From: Wes Pringle, Transportation Engineer
Department of Transportation

Subject: **TRANSPORTATION ASSESSMENT FOR THE PROPOSED MIXED-USE DEVELOPMENT
LOCATED AT 1200 NORTH VINE STREET (CPC-2022-7047-CU-DB-SPR-HCA/ ENV-2022-
7048-CE/PAR-2022-4084-AHRF)**

The Los Angeles Department of Transportation (LADOT) has reviewed the transportation assessment prepared by Gibson Transportation Consulting, Inc. (GTC), dated November 2, 2022, for the proposed mixed-use project at 1200, 1204, 1214, and 1218 North Vine Street and 6245 and 6247 West Lexington Avenue within the Central Area Planning Commission (APC) and a Transit Oriented Community (TOC) Tier 1. In compliance with Senate Bill (SB) 743 and the California Environmental Quality Act (CEQA), a vehicle miles traveled (VMT) analysis is required to identify the project's ability to promote the reduction of green-house gas emissions, the access to diverse land uses, and the development of multi-modal networks. The significance of a project's impact in this regard is measured against the VMT thresholds established in LADOT's Transportation Assessment Guidelines (TAG), as described below.

DISCUSSION AND FINDINGS

A. Project Description

The project proposes to construct an eight-story mixed-use development consisting of 153 (135 multi-family housing and 18 affordable housing) residential units and 7,000 square feet of commercial uses on the northeast corner of Vine Street and Lexington Avenue. A total of 93 vehicle parking spaces and 120 (106 long-term and 14 short-term) bicycle parking spaces will be provided onsite within one ground level and one above-grade level. Parking and the onsite loading zone will be accessed via one shared commercial and residential right-turn ingress and egress driveway on Vine Street and one residential only full access driveway on Lexington Avenue as illustrated in **Attachment A**. The project will also provide 174 (168 residential and six commercial) bicycle parking spaces onsite. The residential bicycle parking will have 153 long-term and 15 short-term spaces and the commercial bicycle parking will have three long-term and three short-term spaces. The project is expected to be completed by 2027.

B. Freeway Safety Analysis

Per the Interim Guidance for Freeway Safety Analysis memorandum issued by LADOT on May 1, 2020 to address Caltrans safety concerns on freeways, the study addresses the project's effects on vehicle queuing on freeway off-ramps. Such an evaluation measures the project's potential to lengthen a forecasted off-ramp queue and create speed differentials between vehicles exiting the freeway off-ramps and vehicles operating on the freeway mainline. The evaluation identified the number of project trips expected to be added to nearby freeway off-ramps serving the project site. It was determined that project traffic at any freeway off-ramp will not exceed 25 peak hour trips. Therefore, a freeway ramp analysis is not required.

C. CEQA Screening Threshold

Prior to accounting for trip reductions resulting from the application of Transportation Demand Management (TDM) Strategies, a trip generation analysis was conducted to determine if the project would exceed the net 250 daily vehicle trips screening threshold. Using the City of Los Angeles VMT Calculator tool, which draws upon trip rate estimates published in the Institute of Transportation Engineers (ITE) Trip Generation Manual, 9th Edition as well as applying trip generation adjustments when applicable, based on sociodemographic data and the built environment factors of the project's surroundings, it was determined that the project **does** exceed the net 250 daily vehicle trips threshold.

Additionally, the analysis included further discussion of the transportation impact thresholds:

- T-1 Conflicting with plans, programs, ordinances, or policies
- T-2.1 Causing substantial vehicle miles traveled
- T-3 Substantially increasing hazards due to a geometric design feature or incompatible use.

The assessment determined that the project would **not** have a significant transportation impact under Thresholds T-1 and T-3. A project's impacts per Threshold T-2.1 is determined by using the VMT calculator and is discussed further below. A copy of the VMT Calculator summary report is provided as **Attachment B** to this report.

D. Transportation Impacts

On July 30, 2019, pursuant to SB 743 and the recent changes to Section 15064.03 of the State's CEQA Guidelines, the City of Los Angeles adopted VMT as criteria in determining transportation impacts under CEQA. The LADOT TAG provide instructions on preparing transportation assessments for land use proposals and defines the significant impact thresholds.

The LADOT VMT Calculator tool measures project impact in terms of Household VMT per Capita, and Work VMT per Employee. LADOT identified distinct thresholds for significant VMT impacts for each of the seven APC areas in the City. For the Central APC area, in which the project is located, the following thresholds have been established:

- Household VMT per Capita: 6.0
- Work VMT per Employee: 7.6

As cited in the VMT Analysis report prepared by GTC, the project proposes to incorporate the TDM strategies of reducing the parking supply from 311 to 93 spaces and including bike parking per Los Angeles Municipal Code (LAMC) as project design features. With the application of this TDM strategy, the proposed project is projected to have a Household VMT per capita of 3.7 and no Work VMT. Therefore, it is concluded that implementation of the project would result in no significant VMT impact. A copy of the VMT Calculator summary report is provided as **Attachment B**.

E. Access and Circulation

During preparation of the new CEQA guidelines, the State's Office of Planning and Research stressed that lead agencies can continue to apply traditional operational analysis requirements to inform land use decisions provided that such analyses were outside of the CEQA process. The authority for requiring non-CEQA transportation analysis and requiring improvements to address potential circulation deficiencies, lies in the City of Los Angeles' Site Plan Review authority as established in Section 16.05 of the LAMC. Therefore, LADOT continues to require

and review a project's site access, circulation, and operational plan to determine if any access enhancements, transit amenities, intersection improvements, traffic signal upgrades, neighborhood traffic calming, or other improvements are needed. In accordance with this authority, the project has completed a circulation analysis using a "level of service" screening methodology that indicates that the trips generated by the proposed development will not likely result in adverse circulation conditions at several locations. Vehicular access to the project will be provided along Vine Street and Lexington Avenue. LADOT has reviewed this analysis and determined that it adequately discloses operational concerns. A copy of the circulation analysis table that summarizes these potential deficiencies is provided as **Attachment C** to this report.

PROJECT REQUIREMENTS

Non-CEQA-Related Requirements and Considerations

To comply with transportation and mobility goals and provisions of adopted City plans and ordinances, the applicant should be required to implement the following:

1. Parking Requirements

The project would provide parking for 93 vehicles and 174 bicycles. The applicant should check with the Departments of Building and Safety and City Planning on the number of parking spaces required for this project within a TOC Tier 3.

2. Highway Dedication and Street Widening Requirements

Per the new Mobility Element of the General Plan, **Vine Street**, an Avenue II, would require a 40-foot half-width roadway within a 55-foot half-width right-of-way and **Lexington Avenue**, a Local Street, would require an 18-foot roadway within a 30-foot half-width right-of-way. The applicant should coordinate with the Bureau of Engineering's Land Development Group who will determine if there are any other applicable highway dedication, street widening and/or sidewalk requirements for this project.

3. Project Access and Circulation

The conceptual site plan for the project (see **Attachment A**) is acceptable to LADOT. The project would be accessed along Vine Street and Lexington Avenue. Review of this study does not constitute approval of the dimensions for any new proposed driveways. Review and approval of new driveways should be coordinated with LADOT's Citywide Planning Coordination Section (201 North Figueroa Street, 5th Floor, Room 550, at 213-482-7024). In order to minimize and prevent last minute building design changes, the applicant should contact LADOT for driveway width and internal circulation requirements prior to the commencement of building or parking layout design. The applicant should check with City Planning regarding the project's vehicular access and design.

4. Worksite Traffic Control Requirements

LADOT recommends that a construction work site traffic control plan be submitted to LADOT's Citywide Temporary Traffic Control Section or Permit Plan Review Section for review and approval prior to the start of any construction work. Refer to <http://ladot.lacity.org/businesses/temporary-traffic-control-plans> to determine which section to coordinate review of the work site traffic control plan. The plan should show the location of any roadway or sidewalk closures, traffic detours, haul routes, hours of operation, protective devices, warning signs and access to abutting properties. LADOT also recommends that all construction related truck traffic be restricted to off-peak hours to the extent feasible.

5. TDM Ordinance Requirements

The TDM Ordinance (LAMC 12.26 J) is currently being updated. The updated ordinance, which is currently progressing through the City's approval process, will:

- Expand the reach and application of TDM strategies to more land uses and neighborhoods,
- Rely on a broader range of strategies that can be updated to keep pace with technology, and
- Provide flexibility for developments and communities to choose strategies that work best for their neighborhood context.

Although not yet adopted, LADOT recommends that the applicant be subject to the terms of the proposed TDM Ordinance update. The updated ordinance is expected to be completed prior to the anticipated construction of this project, if approved.

6. Development Review Fees

Section 19.15 of the LAMC identifies specific fees for traffic study review, condition clearance, and permit issuance. The applicant shall comply with any applicable fees per this ordinance.

If you have any questions, please contact Eileen Hunt of my staff at (213) 972-8481.

Attachments

K:\Letters\2022\CEN22-53727_1200 Vine St_MU_ltr.docx

- c: Council District 13
Hokchi Chiu, Central District, BOE
Bhuvan Bajaj, Hollywood-Wilshire District, DOT
Taimour Tanavoli, Case Management Office, DOT
Lauren Mullarkey-Williams/Emily Wong, GTC

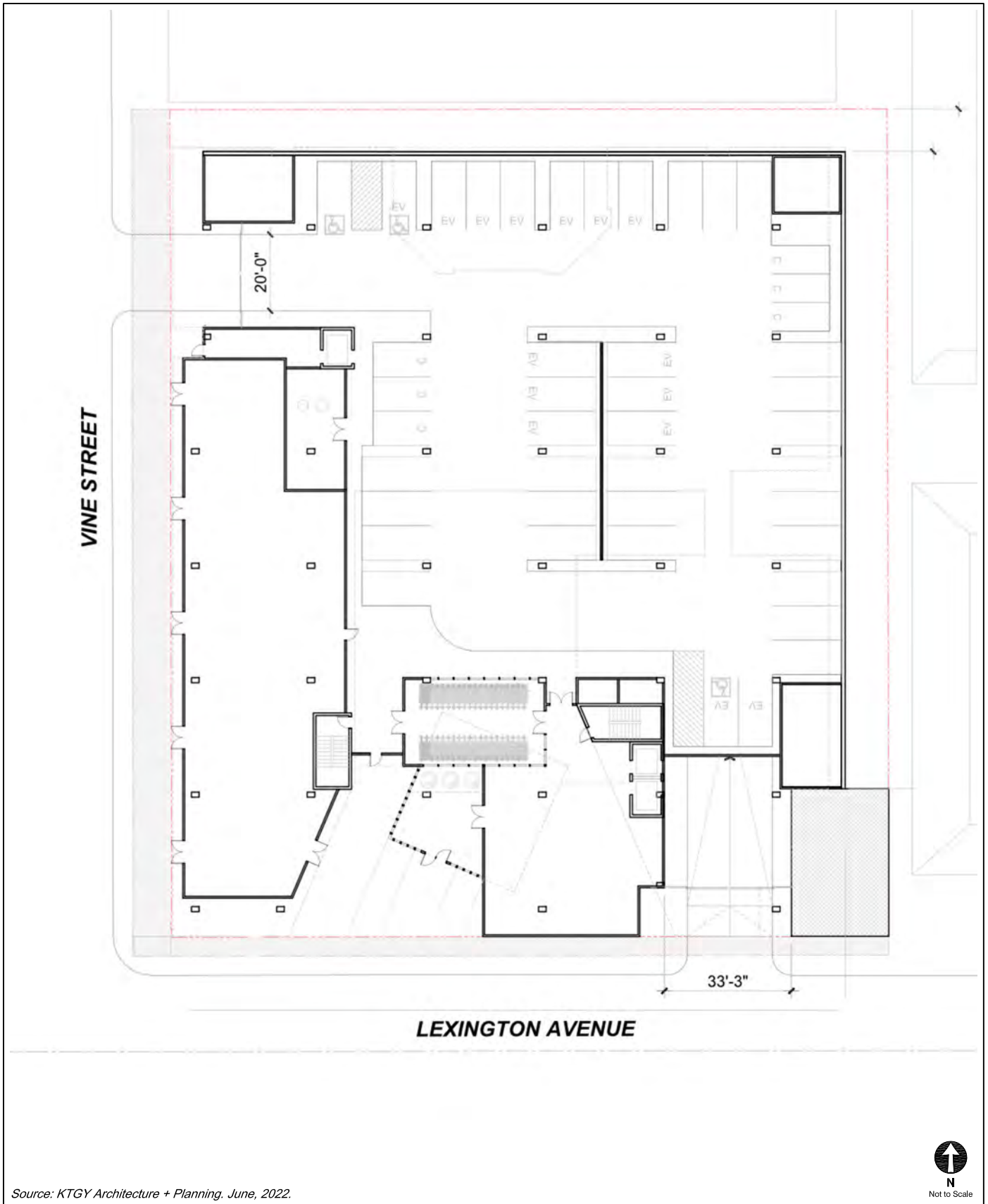

Source: KTG Architecture + Planning, June, 2022.



PROJECT SITE PLAN

FIGURE
1

CITY OF LOS ANGELES VMT CALCULATOR Version 1.3



Project Screening Criteria: Is this project required to conduct a vehicle miles traveled analysis?

Project Information

Project:

Scenario:

Address:

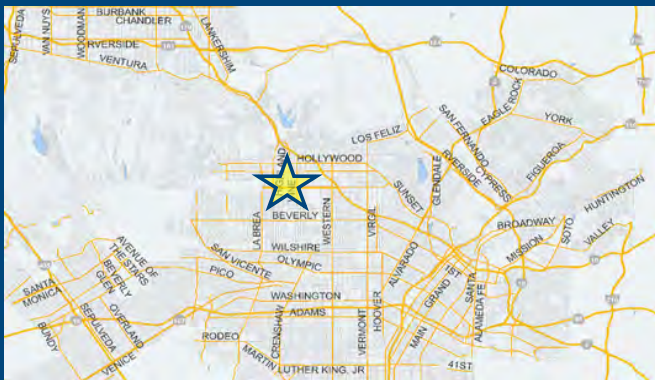

Is the project replacing an existing number of residential units with a smaller number of residential units AND is located within one-half mile of a fixed-rail or fixed-guideway transit

Yes No

Existing Land Use

Land Use Type	Value	Unit
Housing Single Family		DU

[Click here to add a single custom land use type \(will be included in the above list\)](#)

Proposed Project Land Use

Land Use Type	Value	Unit
Retail High-Turnover Sit-Down Restaurant	7	ksf
Housing Multi-Family	135	DU
Housing Affordable Housing - Family	18	DU
Retail High-Turnover Sit-Down Restaurant	7	ksf

[Click here to add a single custom land use type \(will be included in the above list\)](#)

Project Screening Summary

Existing Land Use	Proposed
0 Daily Vehicle Trips	1,025 Daily Vehicle Trips
0 Daily VMT	6,092 Daily VMT
Tier 1 Screening Criteria	
Project will have less residential units compared to existing residential units & is within one-half mile of a fixed-rail station. <input type="checkbox"/>	
Tier 2 Screening Criteria	
The net increase in daily trips < 250 trips	1,025 Net Daily Trips
The net increase in daily VMT ≤ 0	6,092 Net Daily VMT
The proposed project consists of only retail land uses ≤ 50,000 square feet total.	7.000 ksf
The proposed project is required to perform VMT analysis.	



CITY OF LOS ANGELES VMT CALCULATOR Version 1.3



Project Information

Project:

Scenario:

Address:

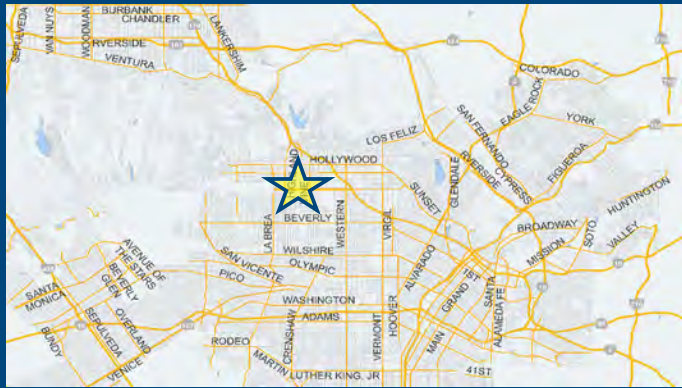

Proposed Project Land Use Type	Value	Unit
Housing Multi-Family	135	DU
Housing Affordable Housing - Family	18	DU
Retail High-Turnover Sit-Down Restaurant	7	ksf

TDM Strategies

Select each section to show individual strategies
Use to denote if the TDM strategy is part of the proposed project or is a mitigation strategy

	Proposed Project	With Mitigation
Max Home Based TDM Achieved?	No	No
Max Work Based TDM Achieved?	No	No

A Parking

B Transit

C Education & Encouragement

D Commute Trip Reductions

E Shared Mobility

F Bicycle Infrastructure

Implement/Improve On-street Bicycle Facility Select Proposed Prj or Mitigation to include this strategy
 Proposed Prj Mitigation

Include Bike Parking Per LAMC Select Proposed Prj or Mitigation to include this strategy
 Proposed Prj Mitigation

Include Secure Bike Parking and Showers Select Proposed Prj or Mitigation to include this strategy
 Proposed Prj Mitigation

G Neighborhood Enhancement

Analysis Results

Proposed Project	With
892 Daily Vehicle Trips	892 Daily Vehicle Trips
5,297 Daily VMT	5,297 Daily VMT
3.7 Household VMT per Capita	3.7 Household VMT
N/A Work VMT per Employee	N/A Work VMT per Employee
Significant VMT Impact?	
Household: No Threshold = 6.0 15% Below APC	Household: No Threshold = 6.0 15% Below APC
Work: N/A Threshold = 7.6 15% Below APC	Work: N/A Threshold = 7.6 15% Below APC



CITY OF LOS ANGELES VMT CALCULATOR

Report 1: Project & Analysis Overview

Date: September 13, 2022

Project Name: 1200 Vine Street

Project Scenario:

Project Address: 1200 N VINE ST, 90038



Version 1.3

Project Information			
Land Use Type		Value	Units
Housing	Single Family	0	DU
	Multi Family	135	DU
	Townhouse	0	DU
	Hotel	0	Rooms
	Motel	0	Rooms
Affordable Housing	Family	18	DU
	Senior	0	DU
	Special Needs	0	DU
	Permanent Supportive	0	DU
Retail	General Retail	0.000	ksf
	Furniture Store	0.000	ksf
	Pharmacy/Drugstore	0.000	ksf
	Supermarket	0.000	ksf
	Bank	0.000	ksf
	Health Club	0.000	ksf
	High-Turnover Sit-Down Restaurant	7.000	ksf
	Fast-Food Restaurant	0.000	ksf
	Quality Restaurant	0.000	ksf
	Auto Repair	0.000	ksf
	Home Improvement	0.000	ksf
	Free-Standing Discount	0.000	ksf
	Movie Theater	0	Seats
	Office	General Office	0.000
Medical Office		0.000	ksf
Industrial	Light Industrial	0.000	ksf
	Manufacturing	0.000	ksf
	Warehousing/Self-Storage	0.000	ksf
School	University	0	Students
	High School	0	Students
	Middle School	0	Students
	Elementary	0	Students
	Private School (K-12)	0	Students
Other		0	Trips

Analysis Results			
Total Employees: 28			
Total Population: 361			
Proposed Project		With Mitigation	
892	Daily Vehicle Trips	892	Daily Vehicle Trips
5,297	Daily VMT	5,297	Daily VMT
3.7	Household VMT per Capita	3.7	Household VMT per Capita
N/A	Work VMT per Employee	N/A	Work VMT per Employee
Significant VMT Impact?			
APC: Central			
Impact Threshold: 15% Below APC Average			
Household = 6.0			
Work = 7.6			
Proposed Project		With Mitigation	
VMT Threshold	Impact	VMT Threshold	Impact
Household > 6.0	No	Household > 6.0	No
Work > 7.6	N/A	Work > 7.6	N/A



TDM Strategy Inputs				
Strategy Type	Description	Proposed Project	Mitigations	
Parking	Reduce parking supply	City code parking provision (spaces)	311	311
		Actual parking provision (spaces)	93	93
	Unbundle parking	Monthly cost for parking (\$)	\$0	\$0
	Parking cash-out	Employees eligible (%)	0%	0%
		Daily parking charge (\$)	\$0.00	\$0.00
	Price workplace parking	Employees subject to priced parking (%)	0%	0%
	Residential area parking permits	Cost of annual permit (\$)	\$0	\$0
(cont. on following page)				
TDM Strategy Inputs, Cont.				
Strategy Type	Description	Proposed Project	Mitigations	
Transit	Reduce transit headways	Reduction in headways (increase in frequency) (%)	0%	0%
		Existing transit mode share (as a percent of total daily trips) (%)	0%	0%
		Lines within project site improved (<50%, =>50%)	0	0
	Implement neighborhood shuttle	Degree of implementation (low, medium, high)	0	0
		Employees and residents eligible (%)	0%	0%
	Transit subsidies	Amount of transit subsidy per passenger (daily equivalent) (\$)	\$0.00	\$0.00
Education & Encouragement	Voluntary travel behavior change program	Employees and residents participating (%)	0%	0%
	Promotions and marketing	Employees and residents participating (%)	0%	0%
(cont. on following page)				
TDM Strategy Inputs, Cont.				
Strategy Type	Description	Proposed Project	Mitigations	
Commuter Trip Reductions	Required commute trip reduction program	Employees participating (%)	0%	0%
		Alternative Work Schedules and Telecommute	Type of program	0
	Employer sponsored vanpool or shuttle	Degree of implementation (low, medium, high)	0	0
		Employees eligible (%)	0%	0%
		Employer size (small, medium, large)	0	0
	Ride-share program	Employees eligible (%)	0%	0%
Shared Mobility	Car share	Car share project setting (Urban, Suburban, All Other)	0	0
	Bike share	Within 600 feet of existing bike share station - OR - implementing new bike share station (Yes/No)	0	0
	School carpool program	Level of implementation (Low, Medium, High)	0	0
(cont. on following page)				
TDM Strategy Inputs, Cont.				
Strategy Type	Description	Proposed Project	Mitigations	
Bicycle Infrastructure	Implements/improve on-street bicycle facility	Provide bicycle facility along site (Yes/No)	0	0
	Include Bike parking per LAMC	Meets City Bike Parking Code (Yes/No)	Yes	Yes
	Include secure bike parking and showers	Includes indoor bike parking/lockers, showers, & repair station (Yes/No)	0	0
Neighborhood Enhancement	Traffic calming improvements	Streets with traffic calming improvements (%)	0%	0%
		Intersections with traffic calming improvements (%)	0%	0%
	Pedestrian network improvements	Included (within project and connecting off-site/within project only)	0	0



Report 3: TDM Outputs

TDM Adjustments by Trip Purpose & Strategy														
Place type: Urban														
		Home Based Work Production		Home Based Work Attraction		Home Based Other Production		Home Based Other Attraction		Non-Home Based Other Production		Non-Home Based Other Attraction		Source
		Proposed	Mitigated	Proposed	Mitigated	Proposed	Mitigated	Proposed	Mitigated	Proposed	Mitigated	Proposed	Mitigated	
Parking	Reduce parking supply	13%	13%	13%	13%	13%	13%	13%	13%	13%	13%	13%	13%	TDM Strategy Appendix, Parking sections 1 - 5
	Unbundle parking	0%	0%	0%	0%	0%	0%	0%	0%	0%	0%	0%	0%	
	Parking cash-out	0%	0%	0%	0%	0%	0%	0%	0%	0%	0%	0%	0%	
	Price workplace parking	0%	0%	0%	0%	0%	0%	0%	0%	0%	0%	0%	0%	
Transit	Residential area parking permits	0.00%	0.00%	0.00%	0.00%	0.00%	0.00%	0.00%	0.00%	0.00%	0.00%	0.00%	0.00%	TDM Strategy Appendix, Transit sections 1 - 3
	Reduce transit headways	0%	0%	0%	0%	0%	0%	0%	0%	0%	0%	0%	0%	
	Implement neighborhood shuttle	0%	0%	0%	0%	0%	0%	0%	0%	0%	0%	0%	0%	
Education & Encouragement	Transit subsidies	0%	0%	0%	0%	0%	0%	0%	0%	0%	0%	0%	0%	TDM Strategy Appendix, Education & Encouragement sections 1 - 2
	Voluntary travel behavior change program	0%	0%	0%	0%	0%	0%	0%	0%	0%	0%	0%	0%	
Commuter Trip Reductions	Promotions and marketing	0%	0%	0%	0%	0%	0%	0%	0%	0%	0%	0%	0%	TDM Strategy Appendix, Commuter Trip Reductions sections 1 - 4
	Required commute trip reduction program	0%	0%	0%	0%	0%	0%	0%	0%	0%	0%	0%	0%	
	Alternative Work Schedules and Telecommute Program	0%	0%	0%	0%	0%	0%	0%	0%	0%	0%	0%	0%	
	Employer sponsored vanpool or shuttle	0%	0%	0%	0%	0%	0%	0%	0%	0%	0%	0%	0%	
Shared Mobility	Ride-share program	0%	0%	0%	0%	0%	0%	0%	0%	0%	0%	0%	0%	TDM Strategy Appendix, Shared Mobility sections 1 - 3
	Car-share	0.00%	0.00%	0.00%	0.00%	0.00%	0.00%	0.00%	0.00%	0.00%	0.00%	0.00%	0.00%	
	Bike share	0.00%	0.00%	0.00%	0.00%	0.00%	0.00%	0.00%	0.00%	0.00%	0.00%	0.00%	0.00%	
	School carpool program	0.0%	0.0%	0.0%	0.0%	0.0%	0.0%	0.0%	0.0%	0.0%	0.0%	0.0%	0.0%	

TDM Adjustments by Trip Purpose & Strategy, Cont.														
Place type: Urban														
		Home Based Work Production		Home Based Work Attraction		Home Based Other Production		Home Based Other Attraction		Non-Home Based Other Production		Non-Home Based Other Attraction		Source
		Proposed	Mitigated	Proposed	Mitigated	Proposed	Mitigated	Proposed	Mitigated	Proposed	Mitigated	Proposed	Mitigated	
Bicycle Infrastructure	Implement/ Improve on-street bicycle facility	0.0%	0.0%	0.0%	0.0%	0.0%	0.0%	0.0%	0.0%	0.0%	0.0%	0.0%	0.0%	TDM Strategy Appendix, Bicycle Infrastructure sections 1 - 3
	Include Bike parking per LAMC	0.6%	0.6%	0.6%	0.6%	0.6%	0.6%	0.6%	0.6%	0.6%	0.6%	0.6%	0.6%	
	Include secure bike parking and showers	0.0%	0.0%	0.0%	0.0%	0.0%	0.0%	0.0%	0.0%	0.0%	0.0%	0.0%	0.0%	
Neighborhood Enhancement	Traffic calming improvements	0.0%	0.0%	0.0%	0.0%	0.0%	0.0%	0.0%	0.0%	0.0%	0.0%	0.0%	0.0%	TDM Strategy Appendix, Neighborhood Enhancement
	Pedestrian network improvements	0.0%	0.0%	0.0%	0.0%	0.0%	0.0%	0.0%	0.0%	0.0%	0.0%	0.0%	0.0%	

Final Combined & Maximum TDM Effect														
		Home Based Work Production		Home Based Work Attraction		Home Based Other Production		Home Based Other Attraction		Non-Home Based Other Production		Non-Home Based Other Attraction		
		Proposed	Mitigated	Proposed	Mitigated	Proposed	Mitigated	Proposed	Mitigated	Proposed	Mitigated	Proposed	Mitigated	
COMBINED TOTAL		13%	13%	13%	13%	13%	13%	13%	13%	13%	13%	13%	13%	
MAX. TDM EFFECT		13%	13%	13%	13%	13%	13%	13%	13%	13%	13%	13%	13%	

$$= \text{Minimum}(X\%, 1 - [(1-A) * (1-B)...])$$

where X%=

PLACE	urban	75%
PLACE TYPE MAX:	compact infill	40%
	suburban center	20%
	suburban	15%

Note: $1 - [(1-A) * (1-B)...]$ reflects the dampened combined effectiveness of TDM Strategies (e.g., A, B,...). See the TDM Strategy Appendix (*Transportation Assessment Guidelines Attachment G*) for further discussion of dampening.

CITY OF LOS ANGELES VMT CALCULATOR

Report 4: MXD Methodology

Date: September 13, 2022

Project Name: 1200 Vine Street

Project Scenario:

Project Address: 1200 N VINE ST, 90038



Version 1.3

MXD Methodology - Project Without TDM

	Unadjusted Trips	MXD Adjustment	MXD Trips	Average Trip Length	Unadjusted VMT	MXD VMT
Home Based Work Production	136	-31.6%	93	7.1	966	660
Home Based Other Production	377	-48.3%	195	4.4	1,659	858
Non-Home Based Other Production	306	-6.9%	285	6.9	2,111	1,967
Home-Based Work Attraction	41	-48.8%	21	8.5	349	179
Home-Based Other Attraction	477	-43.0%	272	5.3	2,528	1,442
Non-Home Based Other Attraction	172	-7.6%	159	6.2	1,066	986

MXD Methodology with TDM Measures

	<i>Proposed Project</i>			<i>Project with Mitigation Measures</i>		
	TDM Adjustment	Project Trips	Project VMT	TDM Adjustment	Mitigated Trips	Mitigated VMT
Home Based Work Production	-13.0%	81	574	-13.0%	81	574
Home Based Other Production	-13.0%	170	746	-13.0%	170	746
Non-Home Based Other Production	-13.0%	248	1,710	-13.0%	248	1,710
Home-Based Work Attraction	-13.0%	18	156	-13.0%	18	156
Home-Based Other Attraction	-13.0%	237	1,254	-13.0%	237	1,254
Non-Home Based Other Attraction	-13.0%	138	857	-13.0%	138	857

MXD VMT Methodology Per Capita & Per Employee

Total Population: 361

Total Employees: 28

APC: Central

	<i>Proposed Project</i>	<i>Project with Mitigation Measures</i>
<i>Total Home Based Production VMT</i>	1,320	1,320
<i>Total Home Based Work Attraction VMT</i>	156	156
<i>Total Home Based VMT Per Capita</i>	3.7	3.7
<i>Total Work Based VMT Per Employee</i>	N/A	N/A

**TABLE 8
 FUTURE CONDITIONS (YEAR 2027)
 INTERSECTION LEVELS OF SERVICE**

No	Intersection [a]	Peak Hour	Future without Project Conditions		Future with Project Conditions	
			Delay	LOS	Delay	LOS
1.	Vine Street & Fountain Avenue	AM	32.2	C	32.7	C
		PM	36.3	D	38.0	D
2.	Vine Street & Lexington Avenue	AM	6.1	A	7.5	A
		PM	9.0	A	9.9	A

Notes:

Delay is measured in seconds per vehicle. LOS = Level of Service.

[a] Intersection analysis based on HCM 6th Edition Signalized methodology, which calculates the average intersection delay, in seconds, for each vehicle passing through the intersection.



DOUGLASKIM+ASSOCIATES,LLC

AMBIENT NOISE MEASUREMENTS



DOUGLASKIM+ASSOCIATES, LLC

Figure 1
Noise Measurement Locations

Source: Google Earth

Session Report

9/14/2022

Information Panel

Name	Hotel 6326 Lexington Avenue
Comments	
Start Time	9/12/2022 1:24:33 PM
Stop Time	9/12/2022 1:39:35 PM
Run Time	00:15:02
Serial Number	SE40213991
Device Name	SE40213991
Model Type	Sound Examiner
Device Firmware Rev	R.11C
Company Name	
Description	
Location	
User Name	

Summary Data Panel

Description	Meter	Value	Description	Meter	Value
Leq	1	57.6 dB			
Exchange Rate	1	3 dB	Weighting	1	A
Response	1	SLOW	Bandwidth	1	OFF

Logged Data Chart

Hotel 6326 Lexington Avenue: Logged Data Chart

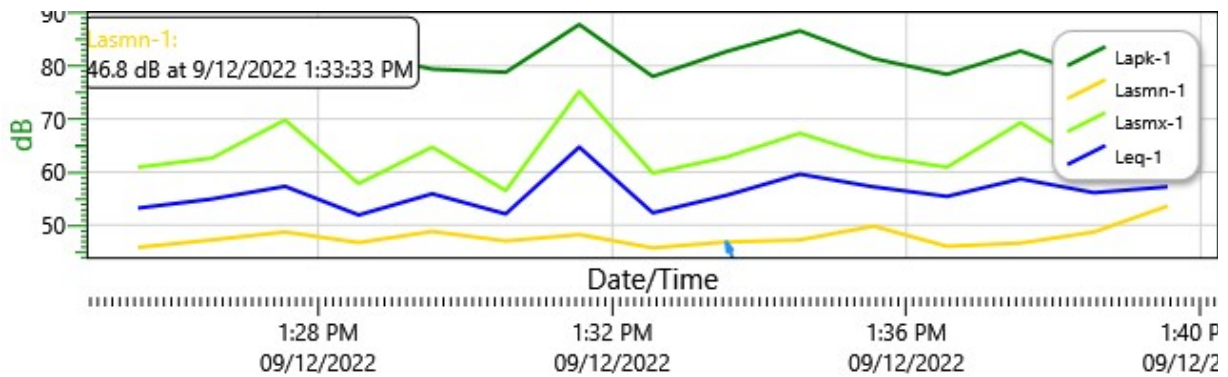

Logged Data Table

Date/Time	Lapk-1	Lasmn-1	Lasmx-1	Leq-1
-----------	--------	---------	---------	-------

Date/Time	Lapk-1	Lasmn-1	Lasmx-1	Leq-1
9/12/2022 1:25:33 PM	87.7	45.8	60.9	53.2
1:26:33 PM	85	47.2	62.6	54.9
1:27:33 PM	88.2	48.7	69.8	57.3
1:28:33 PM	82.3	46.7	57.8	51.9
1:29:33 PM	79.4	48.8	64.7	55.9
1:30:33 PM	78.8	47	56.5	52.1
1:31:33 PM	87.8	48.2	75.2	64.7
1:32:33 PM	78	45.7	59.8	52.3
1:33:33 PM	82.7	46.8	62.8	55.6
1:34:33 PM	86.6	47.2	67.3	59.6
1:35:33 PM	81.4	49.8	63	57.2
1:36:33 PM	78.4	46	60.9	55.4
1:37:33 PM	82.8	46.6	69.3	58.7
1:38:33 PM	77.9	48.7	60.7	56.1
1:39:33 PM	79.9	53.6	61.9	57.2

Session Report

9/14/2022

Information Panel

Name	Hollywood Mental Health Center
Comments	
Start Time	9/12/2022 1:09:09 PM
Stop Time	9/12/2022 1:24:11 PM
Run Time	00:15:02
Serial Number	SE40213991
Device Name	SE40213991
Model Type	Sound Examiner
Device Firmware Rev	R.11C
Company Name	
Description	
Location	
User Name	

Summary Data Panel

Description	Meter	Value	Description	Meter	Value
Leq	1	68.1 dB			
Exchange Rate	1	3 dB	Weighting	1	A
Response	1	SLOW	Bandwidth	1	OFF

Logged Data Chart

Hollywood Mental Health Center: Logged Data Chart

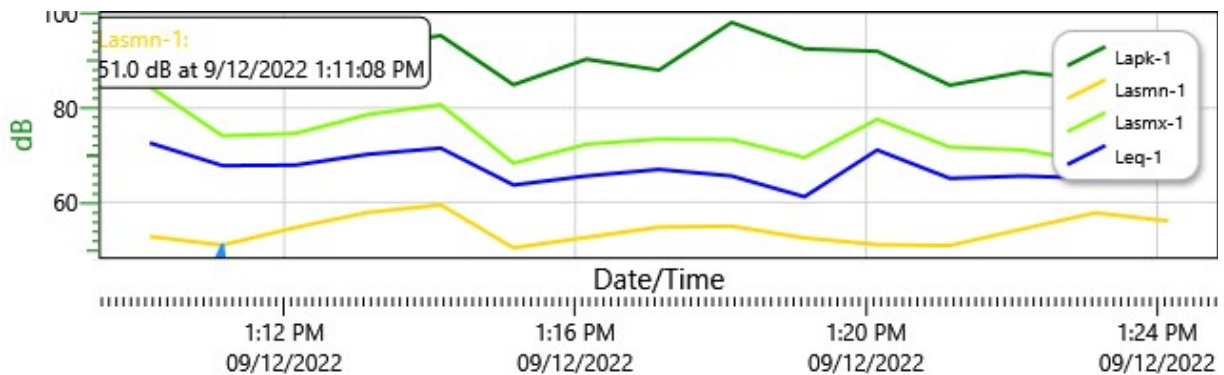

Logged Data Table

Date/Time	Lapk-1	Lasmn-1	Lasmx-1	Leq-1
-----------	--------	---------	---------	-------

Date/Time	Lapk-1	Lasmn-1	Lasmx-1	Leq-1
9/12/2022 1:10:09 PM	97.2	52.8	84.5	72.6
1:11:09 PM	87.2	51	74.1	67.8
1:12:09 PM	87.4	54.7	74.6	67.9
1:13:09 PM	92.9	57.9	78.6	70.2
1:14:09 PM	95.3	59.5	80.7	71.5
1:15:09 PM	84.9	50.4	68.3	63.7
1:16:09 PM	90.3	52.6	72.3	65.6
1:17:09 PM	88	54.8	73.4	67
1:18:09 PM	98.1	55	73.3	65.6
1:19:09 PM	92.5	52.5	69.5	61.2
1:20:09 PM	92	51.1	77.6	71.1
1:21:09 PM	84.8	50.9	71.7	65.1
1:22:09 PM	87.6	54.4	71.1	65.6
1:23:09 PM	86	57.8	68.5	65.1
1:24:09 PM	92.8	56.1	72	66.7

Session Report

9/14/2022

Information Panel

Name	6239 Lexington Avenue
Comments	
Start Time	9/12/2022 12:46:09 PM
Stop Time	9/12/2022 1:01:53 PM
Run Time	00:15:44
Serial Number	SE40213991
Device Name	SE40213991
Model Type	Sound Examiner
Device Firmware Rev	R.11C
Company Name	
Description	
Location	
User Name	

Summary Data Panel

Description	Meter	Value	Description	Meter	Value
Leq	1	59.5 dB			
Exchange Rate	1	3 dB	Weighting	1	A
Response	1	SLOW	Bandwidth	1	OFF

Logged Data Chart

6239 Lexington Avenue: Logged Data Chart

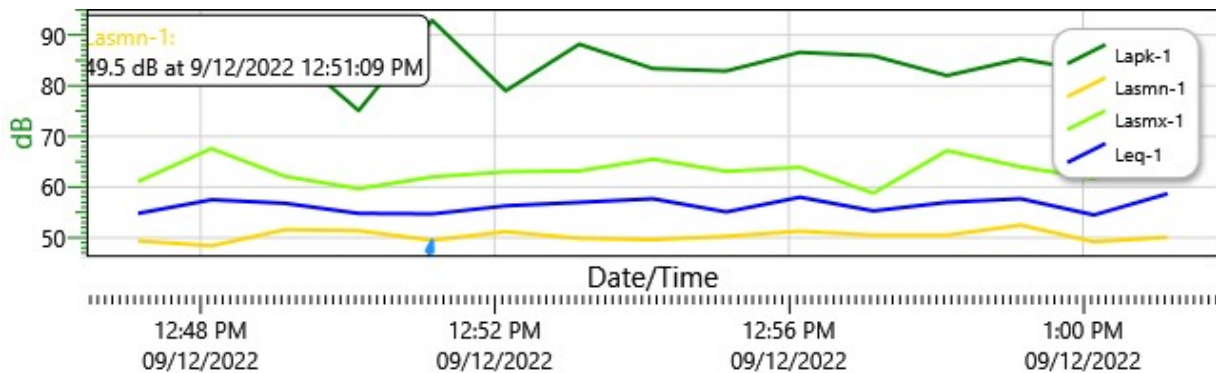

Logged Data Table

Date/Time	Lapk-1	Lasmn-1	Lasmx-1	Leq-1
-----------	--------	---------	---------	-------

Date/Time	Lapk-1	Lasmn-1	Lasmx-1	Leq-1
9/12/2022 12:47:09 PM	87.9	49.4	61.1	54.8
12:48:09 PM	86.3	48.4	67.6	57.5
12:49:09 PM	87.5	51.6	62.1	56.8
12:50:09 PM	75.1	51.4	59.7	54.8
12:51:09 PM	92.9	49.5	62	54.7
12:52:09 PM	79	51.2	63	56.3
12:53:09 PM	88.2	49.9	63.2	57
12:54:09 PM	83.4	49.6	65.5	57.7
12:55:09 PM	82.9	50.3	63.1	55.1
12:56:09 PM	86.6	51.3	63.9	58
12:57:09 PM	85.9	50.5	58.8	55.3
12:58:09 PM	82	50.5	67.2	57
12:59:09 PM	85.3	52.5	64	57.7
1:00:09 PM	82.8	49.2	61.7	54.5
1:01:09 PM	87.7	50.1	65.7	58.7

Session Report

9/14/2022

Information Panel

Name	Hampton Hotel
Comments	
Start Time	9/12/2022 1:40:19 PM
Stop Time	9/12/2022 1:55:20 PM
Run Time	00:15:01
Serial Number	SE40213991
Device Name	SE40213991
Model Type	Sound Examiner
Device Firmware Rev	R.11C
Company Name	
Description	
Location	
User Name	

Summary Data Panel

Description	Meter	Value	Description	Meter	Value
Leq	1	66.7 dB			
Exchange Rate	1	3 dB	Weighting	1	A
Response	1	SLOW	Bandwidth	1	OFF

Logged Data Chart

Hampton Hotel: Logged Data Chart

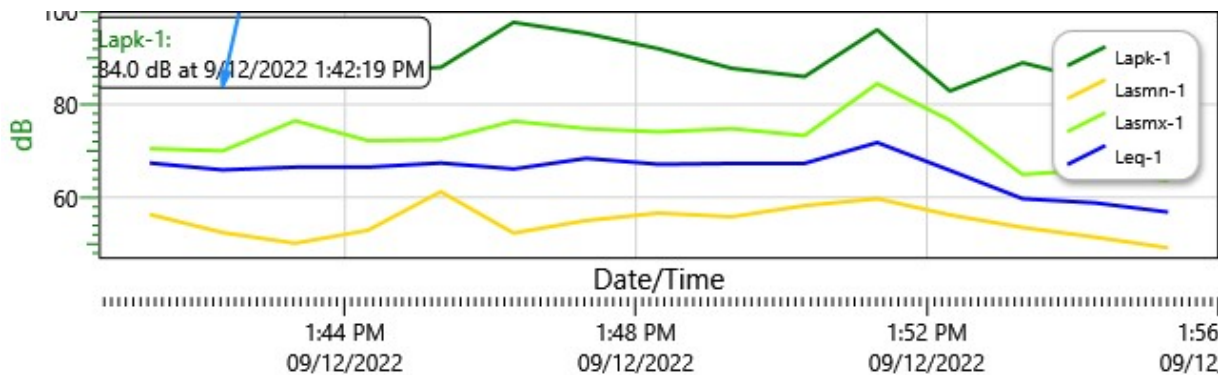

Logged Data Table

Date/Time	Lapk-1	Lasmn-1	Lasmx-1	Leq-1
-----------	--------	---------	---------	-------

Date/Time	Lapk-1	Lasmn-1	Lasmx-1	Leq-1
9/12/2022 1:41:19 PM	85.1	56.3	70.5	67.4
1:42:19 PM	84	52.4	70	65.9
1:43:19 PM	89.5	50.1	76.5	66.5
1:44:19 PM	87.1	52.9	72.2	66.5
1:45:19 PM	88	61.2	72.4	67.4
1:46:19 PM	97.7	52.3	76.4	66.1
1:47:19 PM	95.3	55	74.8	68.4
1:48:19 PM	92	56.6	74.1	67.1
1:49:19 PM	87.8	55.8	74.8	67.3
1:50:19 PM	86	58.2	73.3	67.3
1:51:19 PM	96.1	59.7	84.5	71.8
1:52:19 PM	82.9	56.2	76.6	65.8
1:53:19 PM	89	53.5	64.9	59.7
1:54:19 PM	85.1	51.4	66	58.8
1:55:19 PM	80.6	49.1	63.5	56.8



DOUGLASKIM+ASSOCIATES,LLC

CONSTRUCTION NOISE CALCULATIONS

Noise emissions of industry sources

Source name	Size m/m ²	Reference	Day dB(A)	Level		Corrections		
				Evening dB(A)	Night dB(A)	Cwall dB	CI dB	CT dB
Construction Site	3922 m ²	Lw/unit	109.7	-	-	-	-	-

Receiver list

No.	Receiver name	Coordinates		Building side	Floor	Height abv.grd. m	Limit Day dB(A)	Level Day dB(A)	Conflict Day dB
		X	Y						
1	Early Head Start School	11377600.9	3773181.00	East	GF	97.73	-	58.6	-
2	Hotel -1133 Vine St.	11377597.0	3773134.38	East	GF	96.08	-	53.8	-
3	Hotel - 6326 Lexington Ave.	11377558.3	3773208.00	North	GF	96.83	-	56.9	-
4	Mental Health Center	11377631.8	3773300.35	West	GF	98.40	-	58.5	-
5	Residences - 6230-40 Lexington Ave.	11377691.4	3773200.49	North	GF	97.35	-	60.9	-
6	Residences - 6231-39 Lexington Ave.	11377701.1	3773226.73	South	GF	98.57	-	61.4	-
7	Residences - 6232-38 La Mirada Ave.	11377698.8	3773307.22	North	GF	99.01	-	49.2	-
8	Taglyan Complex	11377601.1	3773261.83	East	GF	97.81	-	64.0	-

Contribution levels of the receivers

Source name	Traffic lane	Level Day dB(A)
Early Head Start School GF		58.6
Construction Site	-	58.6
Hotel -1133 Vine St. GF		53.8
Construction Site	-	53.8
Hotel - 6326 Lexington Ave. GF		56.9
Construction Site	-	56.9
Mental Health Center GF		58.5
Construction Site	-	58.5
Residences - 6230-40 Lexington Ave. GF		60.9
Construction Site	-	60.9
Residences - 6231-39 Lexington Ave. GF		61.4
Construction Site	-	61.4
Residences - 6232-38 La Mirada Ave. GF		49.2
Construction Site	-	49.2
Taglyan Complex GF		64.0
Construction Site	-	64.0

1200 Vine Street

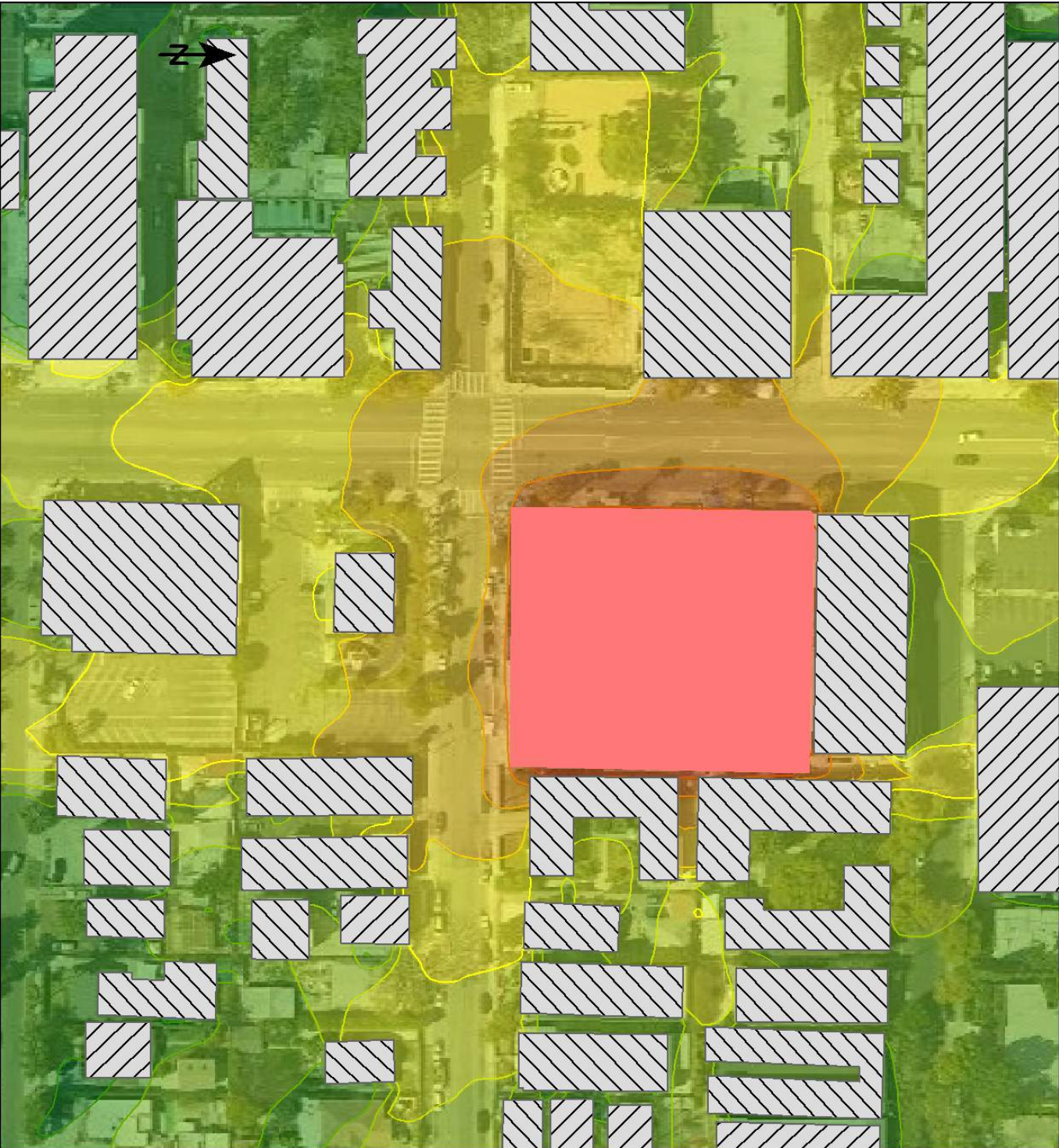

Signs and symbols

-  Building
-  Construction Site

Levels in dB(A)

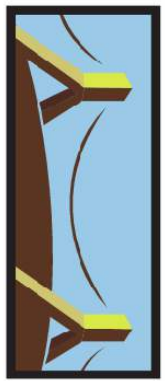
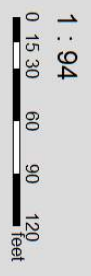
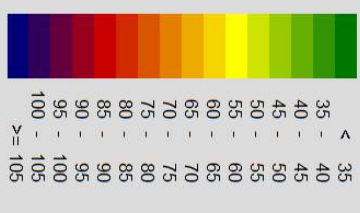

DOUGLASSKIM+ASSOCIATES, LLC

1200 Vine Street

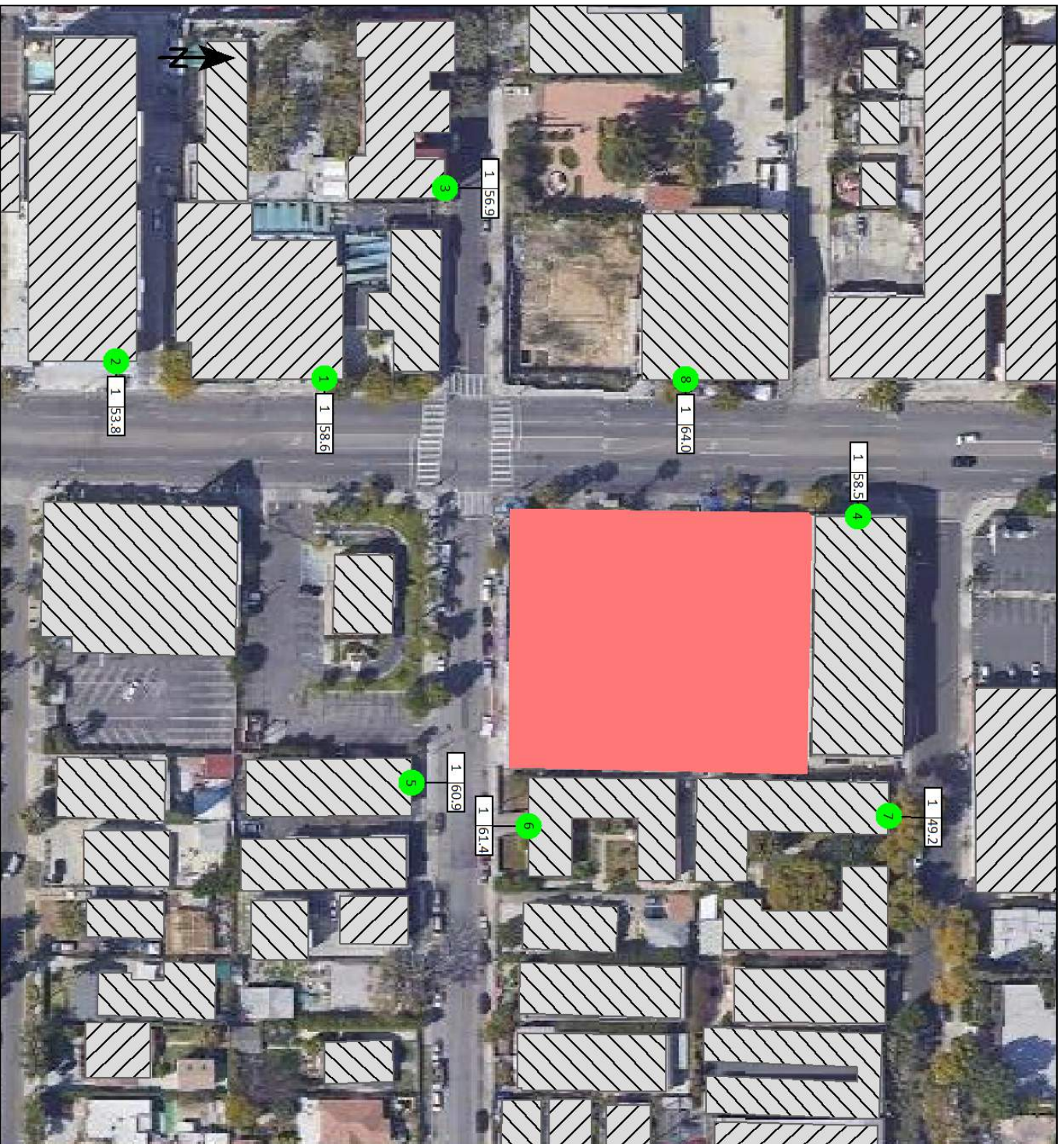

Signs and symbols

-  Building
-  Analyzed Sensitive Receptor
-  Construction Site

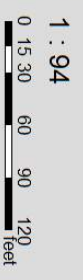

DOUGLASSKIM+ASSOCIATES, LLC

Construction Noise Impacts



DOUGLASKIM+ASSOCIATES,LLC

Reference	15.24	meter
Sound Pressure Level (Lp)	75.0	dBA
Sound Power Level (Lw)	109.7	dB

Receptor	Existing Leq	Noise	New Leq	Difference Leq	Significant?
Taglyan Complex	68.1	64.0	69.5	1.4	No
Mental Health Center	68.1	58.5	68.6	0.5	No
Early Head Start School	66.7	58.6	67.3	0.6	No
Residences - 6231-39 Lexington Ave.	59.5	61.4	63.6	4.1	No
Hotel - 1133 Vine St.	66.7	53.8	66.9	0.2	No
Residences - 6230-40 Lexington Ave.	59.5	60.9	63.3	3.8	No
Hotel - 6326 Lexington Ave.	57.6	56.9	60.3	2.7	No
Residences - 6232-38 La Mirada Ave.	59.5	49.2	59.9	0.4	No

Note: Sound Power Level (Lw) assumes full sphere propagation



DOUGLASKIM+ASSOCIATES,LLC

OPERATIONS NOISE CALCULATIONS



Hourly Distribution of Entering and Exiting Vehicle Trips by Land Use

Source: ITE Trip Generation Manual , 10th Edition

Land Use Code	221					
	General Urban/Suburban		Dense Multi-Use Urban		Center City Core	
Setting	Weekday		Weekday		Weekday	
Time Period	Vehicle		Vehicle		Vehicle	
Trip Type	8		4		3	
# Data Sites	%		%		%	
	of 24-Hour Traffic		of 24-Hour Traffic		of 24-Hour Traffic	
Time	Entering	Exiting	Entering	Exiting	Entering	Exiting
12-1 AM	0.7	0.3	0.8	0.2	2.6	0
1-2 AM	0.3	0.2	1.3	0.1	0.4	0
2-3 AM	0.2	0.2	0.8	0.3	0.9	0.9
3-4 AM	0.4	0.3	0.6	0.3	0.4	0
4-5 AM	0.3	0.8	0.6	0.0	0.4	1.8
5-6 AM	0.6	2.7	2.3	1.6	0.4	3.1
6-7 AM	1.5	6.5	4.1	4.1	1.8	8.0
7-8 AM	2.8	12.1	4.2	17.7	5.3	12.0
8-9 AM	3.5	8.8	5.1	9.2	4.8	10.2
9-10 AM	2.9	5.7	2.5	5.6	5.7	4.9
10-11 AM	2.7	4.7	4.4	3.8	2.2	4.9
11-12 PM	4.5	4.5	3.1	5.7	3.9	2.7
12-1 PM	4.8	4.6	4.7	5.2	4.4	2.7
1-2 PM	4.1	4.8	5.3	3.7	3.9	6.7
2-3 PM	5.8	5.0	5.9	3.3	3.9	4.9
3-4 PM	6.7	4.9	6.2	4.4	6.1	4.0
4-5 PM	10.6	6.2	10.0	4.7	4.8	5.8
5-6 PM	12.6	7.7	8.7	4.1	8.3	7.6
6-7 PM	9.3	6.6	6.7	8.6	8.8	4.0
7-8 PM	7.8	4.8	6.7	4.4	7.9	4.4
8-9 PM	7.0	3.3	5.1	4.3	7.0	2.2
9-10 PM	5.5	2.2	4.6	3.1	5.3	4.9
10-11 PM	3.6	1.9	4.4	2.8	7.0	3.1
11-12 AM	2.0	1.1	1.9	2.8	3.5	1.3
			Hourly Trips	Average Daytime	Average Nighttime	
12-1 AM	1.0	0.5	2		2	
1-2 AM	0.5	0.25	1		1	
2-3 AM	0.4	0.2	1		1	
3-4 AM	0.7	0.35	2		2	
4-5 AM	1.1	0.55	2		2	
5-6 AM	3.3	1.65	7		7	
6-7 AM	8.0	4	18		18	
7-8 AM	14.9	7.45	33	33		
8-9 AM	12.3	6.15	27	27		
9-10 AM	8.6	4.3	19	19		
10-11 AM	7.4	3.7	17	17		
11-12 PM	9.0	4.5	20	20		
12-1 PM	9.4	4.7	21	21		
1-2 PM	8.9	4.45	20	20		
2-3 PM	10.8	5.4	24	24		
3-4 PM	11.6	5.8	26	26		
4-5 PM	16.8	8.4	37	37		
5-6 PM	20.3	10.15	45	45		
6-7 PM	15.9	7.95	35	35		
7-8 PM	12.6	6.3	28		28	
8-9 PM	10.3	5.15	23		23	
9-10 PM	7.7	3.85	17		17	
10-11 PM	5.5	2.75	12		12	
11-12 AM	3.1	1.55	7		7	
ADT (Vine St Driveway)			446	27	10	

Project: 1200 Vine Street

Receiver Parameters	
Receiver:	Taghyan Complex
Land Use Category:	3. Institutional
Existing Noise (Measured or Generic Value):	56 dBA

Noise Source Parameters
 Number of Noise Sources: 1

Noise Source Parameters	
Source 1	Source 1
Source Type:	Stationary Source
Specific Source:	Parking Garage
Noisest hr of Activity During Sensitive hrs	Number of Autos/hr: 64
Distance	Distance from Source to Receiver (ft): 100
Adjustments	Number of Intervening Rows of Buildings: 0
	Noise Barrier? No
	Joint Track/Crossover? No
	Embedded Track? No
	Aerial Structure? No

Noise Barrier?	
Joint Track/Crossover?	
Embedded Track?	
Aerial Structure?	

Noise Barrier?	
Joint Track/Crossover?	
Embedded Track?	
Aerial Structure?	

Noise Barrier?	
Joint Track/Crossover?	
Embedded Track?	
Aerial Structure?	

Noise Barrier?	
Joint Track/Crossover?	
Embedded Track?	
Aerial Structure?	

Noise Barrier?	
Joint Track/Crossover?	
Embedded Track?	
Aerial Structure?	

Project Results Summary	
Existing Leqhr:	56 dBA
Total Project Leqhr:	56 dBA
Total Noise Exposure:	56 dBA
Increase:	0 dB
Impact?	None

Distance to Impact Contours	
Dist to Mod. Impact Contour:	(Source 1): 11 ft
Dist to Sev. Impact Contour:	(Source 1): 6 ft

Source 1 Results	
Leqhr:	36.2 dBA

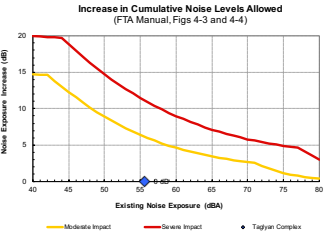
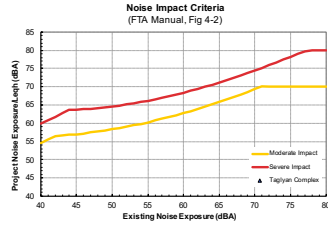

Project: 1200 Vine Street
Receiver: Taglyan Complex

Source	Distance	Project Leq _h	Existing Leq _h	Noise Criteria			Impact?
				Mod. Impact	Sev. Impact		
1 Parking Garage	100 ft	36.2 dBA	56 dBA	60 dBA	66 dBA		None
2 --	50 ft		56 dBA	60 dBA	66 dBA		
3 --	50 ft		56 dBA	60 dBA	66 dBA		
4 --	70 ft		56 dBA	60 dBA	66 dBA		
5 --	ft		56 dBA	60 dBA	66 dBA		
6 --	ft	0.0 dBA	56 dBA	60 dBA	66 dBA		None
Combined Sources		36 dBA	56 dBA	60 dBA	66 dBA		None

Noise Impact Criteria
(FTA Manual, Fig 3-1)

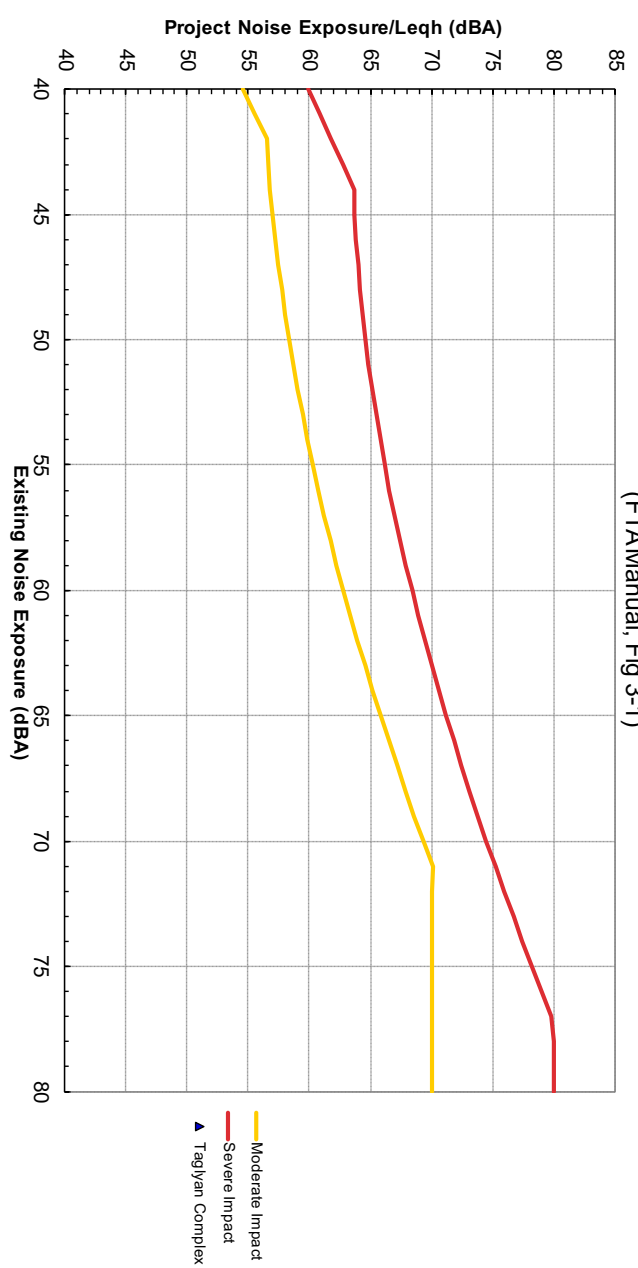

Increase in Cumulative Noise Levels Allowed
(FTA Manual, Fig 3-2)

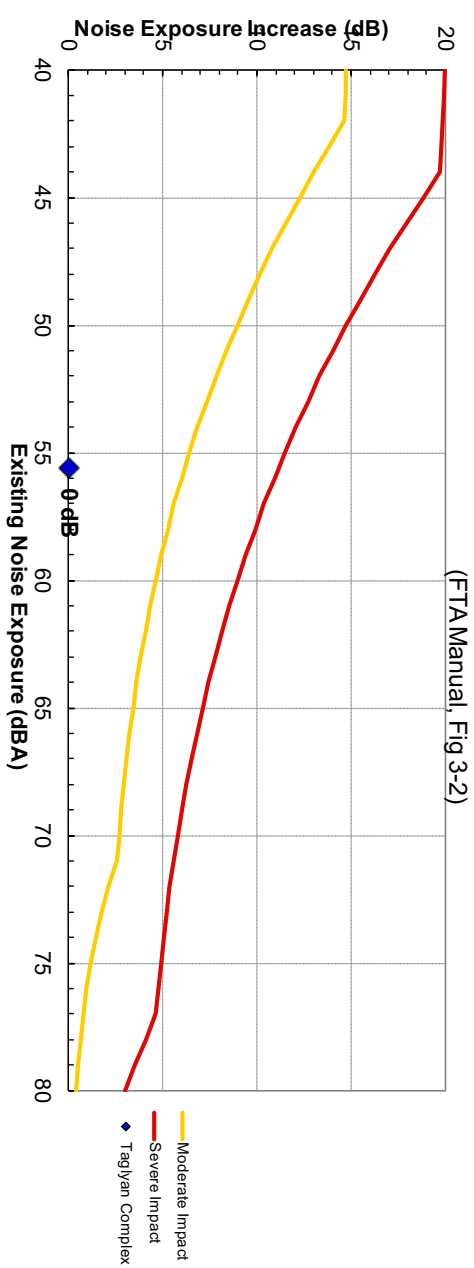



Hourly Distribution of Entering and Exiting Vehicle Trips by Land Use

Source: ITE Trip Generation Manual , 10th Edition

Land Use Code Setting Time Period Trip Type # Data Sites	221 Multifamily Housing (Mid-Rise)					
	General Urban/Suburban		Dense Multi-Use Urban		Center City Core	
	Weekday		Weekday		Weekday	
	Vehicle 8		Vehicle 4		Vehicle 3	
	% of 24-Hour Traffic		% of 24-Hour Traffic		% of 24-Hour Traffic	
Time	Entering	Exiting	Entering	Exiting	Entering	Exiting
12-1 AM	0.7	0.3	0.8	0.2	2.6	0
1-2 AM	0.3	0.2	1.3	0.1	0.4	0
2-3 AM	0.2	0.2	0.8	0.3	0.9	0.9
3-4 AM	0.4	0.3	0.6	0.3	0.4	0
4-5 AM	0.3	0.8	0.6	0.0	0.4	1.8
5-6 AM	0.6	2.7	2.3	1.6	0.4	3.1
6-7 AM	1.5	6.5	4.1	4.1	1.8	8.0
7-8 AM	2.8	12.1	4.2	17.7	5.3	12.0
8-9 AM	3.5	8.8	5.1	9.2	4.8	10.2
9-10 AM	2.9	5.7	2.5	5.6	5.7	4.9
10-11 AM	2.7	4.7	4.4	3.8	2.2	4.9
11-12 PM	4.5	4.5	3.1	5.7	3.9	2.7
12-1 PM	4.8	4.6	4.7	5.2	4.4	2.7
1-2 PM	4.1	4.8	5.3	3.7	3.9	6.7
2-3 PM	5.8	5.0	5.9	3.3	3.9	4.9
3-4 PM	6.7	4.9	6.2	4.4	6.1	4.0
4-5 PM	10.6	6.2	10.0	4.7	4.8	5.8
5-6 PM	12.6	7.7	8.7	4.1	8.3	7.6
6-7 PM	9.3	6.6	6.7	8.6	8.8	4.0
7-8 PM	7.8	4.8	6.7	4.4	7.9	4.4
8-9 PM	7.0	3.3	5.1	4.3	7.0	2.2
9-10 PM	5.5	2.2	4.6	3.1	5.3	4.9
10-11 PM	3.6	1.9	4.4	2.8	7.0	3.1
11-12 AM	2.0	1.1	1.9	2.8	3.5	1.3

	Hourly Trips		Average Daytime	Average Nighttime
12-1 AM	1.0	0.5	2	2
1-2 AM	0.5	0.25	1	1
2-3 AM	0.4	0.2	1	1
3-4 AM	0.7	0.35	2	2
4-5 AM	1.1	0.55	2	2
5-6 AM	3.3	1.65	7	7
6-7 AM	8.0	4	18	18
7-8 AM	14.9	7.45	33	33
8-9 AM	12.3	6.15	27	27
9-10 AM	8.6	4.3	19	19
10-11 AM	7.4	3.7	17	17
11-12 PM	9.0	4.5	20	20
12-1 PM	9.4	4.7	21	21
1-2 PM	8.9	4.45	20	20
2-3 PM	10.8	5.4	24	24
3-4 PM	11.6	5.8	26	26
4-5 PM	16.8	8.4	37	37
5-6 PM	20.3	10.15	45	45
6-7 PM	15.9	7.95	35	35
7-8 PM	12.6	6.3	28	28
8-9 PM	10.3	5.15	23	23
9-10 PM	7.7	3.85	17	17
10-11 PM	5.5	2.75	12	12
11-12 AM	3.1	1.55	7	7
ADT (Lexington Ave Driveway)			446	
				27
				10

Project: 1200 Vine Street

Receiver Parameters	
Receiver:	Residences - 6236-40 Lexington Ave.
Land Use Category:	2 - Residential
Existing Noise (Measured or Generic Value):	56 dBA

Number of Noise Sources: 1

Noise Source Parameters	
Source 1	
Source Type:	Stationary Source
Specific Source:	Parking Garage
Daytime hrs	Avg. Number of Autos/hr: 27
Nighttime hrs	Avg. Number of Autos/hr: 10
Distance	Distance from Source to Receiver (ft): 80
Adjustments	Number of Intervening Rows of Buildings: 0
	Noise Barrier? No
	Joint Track/Crossover? No
	Embedded Track? No
	Aerial Structure? No

	Noise Barrier? No
	Joint Track/Crossover? No
	Embedded Track? No
	Aerial Structure? No

	Noise Barrier? No
--	-------------------

	Noise Barrier? No
--	-------------------

	Noise Barrier? No
--	-------------------

	Noise Barrier? No
--	-------------------

Project Results Summary	
Existing Ldn:	56 dBA
2024 Project Ldn:	56 dBA
2024 Noise Exposure:	56 dBA
Increase:	0 dB
Impact?	None
Distance to Impact Contours	
Dist to Mod. Impact Contour:	(Source 1): 17 ft
Dist to Sev. Impact Contour:	(Source 1): 10 ft

Source 1 Results	
Leq(day):	35.6 dBA
Leq(night):	31.3 dBA
Ldn:	38.7 dBA

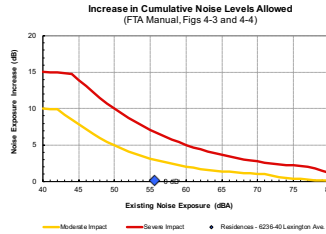
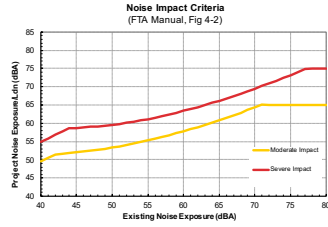

Project: 1200 Vine Street
Receiver: Residences - 6236-40 Lexington Ave.

Source	Distance	Project Ldn	Existing Ldn	Noise Criteria			Impact?
				Mod. Impact	Sev. Impact		
1 Parking Garage	80 ft	38.7 dBA	56 dBA	55 dBA	61 dBA	61 dBA	None
2 --	50 ft		56 dBA	55 dBA	61 dBA	61 dBA	
3 --	50 ft		56 dBA	55 dBA	61 dBA	61 dBA	
4 --	70 ft		56 dBA	55 dBA	61 dBA	61 dBA	
5 --	ft		56 dBA	55 dBA	61 dBA	61 dBA	
6 --	ft		56 dBA	55 dBA	61 dBA	61 dBA	
Combined Sources		39 dBA	56 dBA	55 dBA	61 dBA	61 dBA	None

Noise Impact Criteria
(FTA Manual, Fig 3-1)

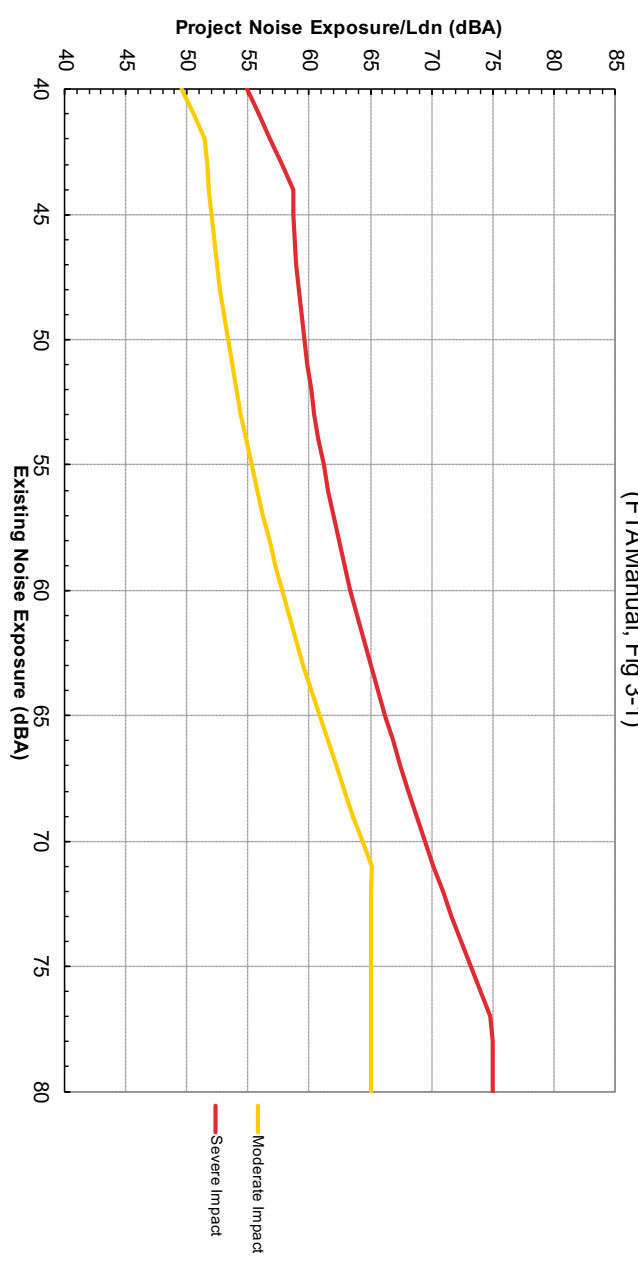

Increase in Cumulative Noise Levels Allowed
(FTA Manual, Fig 3-2)

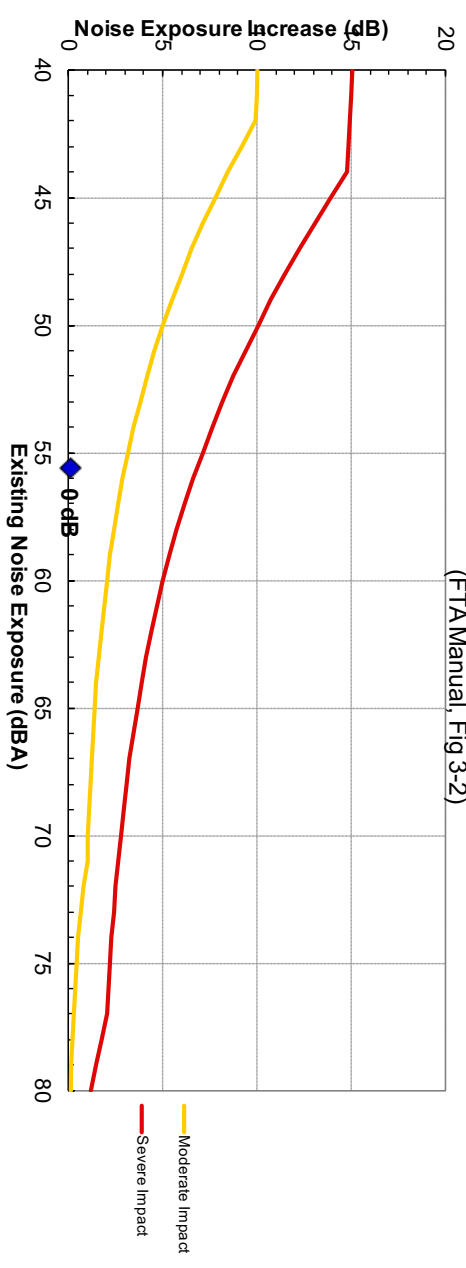



DOUGLASKIM+ASSOCIATES,LLC

DEMOLITION ANALYSIS



Douglas Kim + Associates, LLC

CONSTRUCTION BUILDING DEBRIS

Materials	Total SF	Height	Cubic Yards	Pounds per Cub	Tons	Truck Capacity (CY)	Truck Trips	Source
Construction and Debris	0	0	-	484	-	10	-	Florida Department of Environmental Protection A Fact Sheet for C&D Debris Facility Operators <i>Federal Emergency Management Agency, Debris Estimating Field Guide (FEMA 329), September 2010. General Building Formula</i>
General Building	27,011	12	3,962	1,000	1,981	10	792	<i>Federal Emergency Management Agency, Debris Estimating Field Guide (FEMA 329), September 2010. Single Family Residence Formula, assumes 1 story, Medium vegetative cover multiplier (1.3)</i>
Single Family Residence	-	12	-	1,000	-	10	-	
Multi-Family Residence	-	12	-	1,000	-	10	-	
Mobile Home	-	-	-	1,000	-	10	-	
Mixed Debris	-	-	-	480	-	10	-	Florida Department of Environmental Protection A Fact Sheet for C&D Debris Facility Operators
Vegetative Debris (Hardwoods)	-	-	-	500	-	10	-	
Vegetative Debris (Softwoods)	-	-	-	333	-	10	-	
Asphalt or concrete (Constructor	16,000	0.5	296	2,400	356	10	59	
TOTAL			4,258		2,336		852	



DOUGLASKIM+ASSOCIATES,LLC

CUMULATIVE PROJECTS

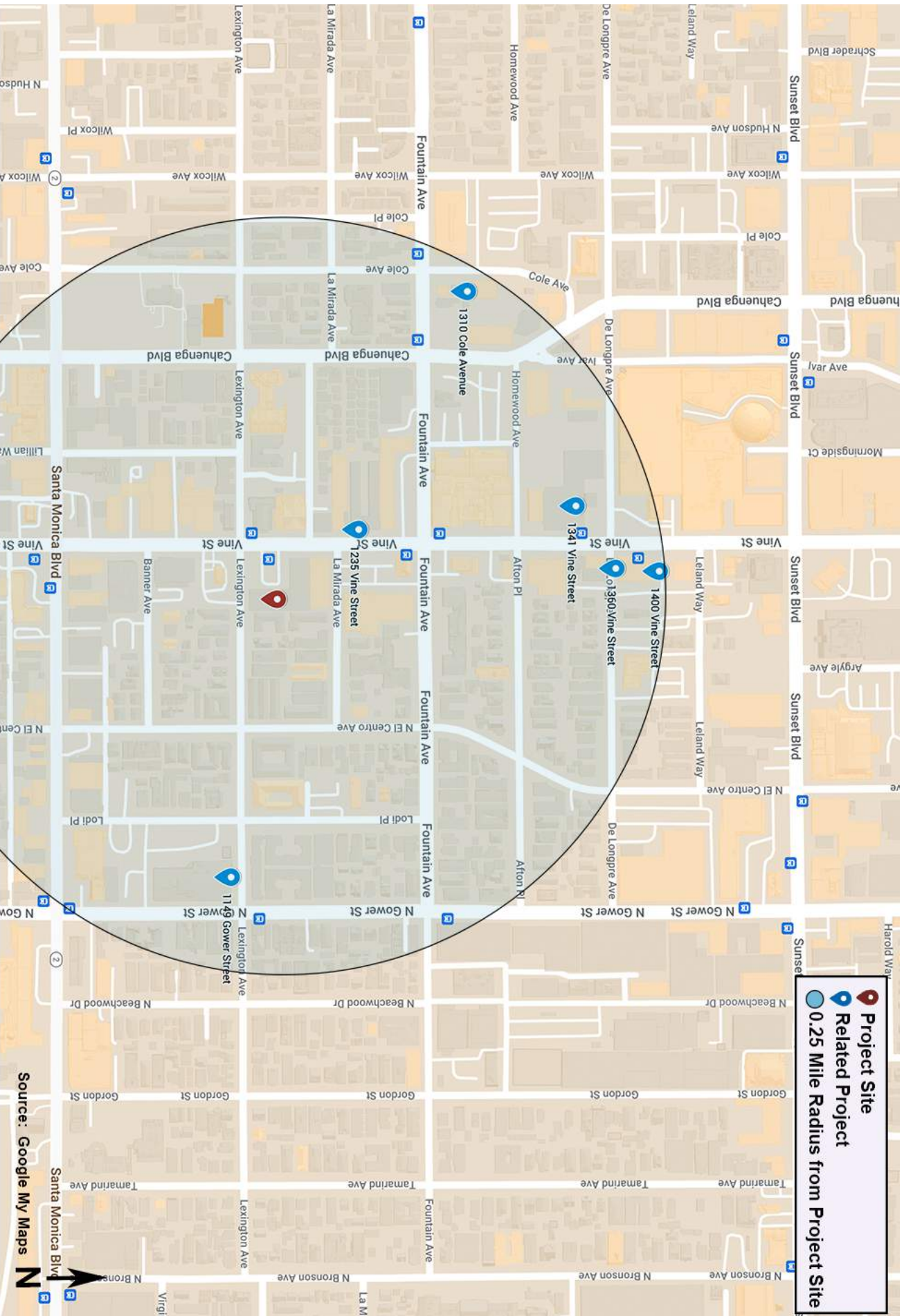

- Project Site
- Related Project
- 0.25 Mile Radius from Project Site



DOUGLASKIM+ASSOCIATES, LLC

Source: Google My Maps





DOUGLASKIM+ASSOCIATES,LLC

CUMULATIVE CONSTRUCTION NOISE IMPACTS

Noise emissions of industry sources

Source name	Size m/m ²	Reference	Level			Corrections		
			Day dB(A)	Evening dB(A)	Night dB(A)	Cwall dB	CI dB	CT dB
Construction Site	3922 m ²	Lw/unit	109.7	-	-	-	-	-
Construction Site (Related Project - 1235 Vine St)	1383 m ²	Lw/unit	109.7	-	-	-	-	-
Construction Site (Related Project - 1360 Vine St)	586 m ²	Lw/unit	109.7	-	-	-	-	-
Construction Site (Related Project - 1440 Vine St)	606 m ²	Lw/unit	109.7	-	-	-	-	-
Construction Site (Related Project - 1149 Gower St)	7155 m ²	Lw/unit	109.7	-	-	-	-	-

Receiver list

No.	Receiver name	Coordinates		Building side	Floor	Height abv. grd. m	Limit Day dB(A)	Level Day dB(A)	Conflict Day dB
		X	Y						
1	Early Head Start School	11377600.9	3773181.00	East	GF	97.73	-	58.9	-
2	Hotel -1133 Vine St.	11377597.0	3773134.38	East	GF	96.08	-	54.7	-
3	Hotel - 6326 Lexington Ave.	11377558.3	3773208.00	North	GF	96.83	-	58.6	-
4	Mental Health Center	11377631.8	3773300.35	West	GF	98.40	-	63.0	-
5	Residences - 6230-40 Lexington Ave.	11377691.4	3773200.49	North	GF	97.35	-	61.5	-
6	Residences - 6231-39 Lexington Ave.	11377701.1	3773226.73	South	GF	98.57	-	61.4	-
7	Residences - 6232-38 La Mirada Ave.	11377698.8	3773307.22	North	GF	99.01	-	52.4	-
8	Taglyan Complex	11377601.1	3773261.83	East	GF	97.81	-	64.3	-

Contribution levels of the receivers

Source name	Traffic lane	Level Day dB(A)
Early Head Start School	GF	58.9
Construction Site	-	58.8
Construction Site (Related Project - 114	-	33.1
Construction Site (Related Project - 123	-	36.3
Construction Site (Related Project - 136	-	38.1
Construction Site (Related Project - 144	-	40.4
Hotel -1133 Vine St.	GF	54.7
Construction Site	-	54.6
Construction Site (Related Project - 114	-	30.1
Construction Site (Related Project - 123	-	32.9
Construction Site (Related Project - 136	-	23.1
Construction Site (Related Project - 144	-	22.4
Hotel - 6326 Lexington Ave.	GF	58.6
Construction Site	-	57.3
Construction Site (Related Project - 114	-	28.1
Construction Site (Related Project - 123	-	52.6
Construction Site (Related Project - 136	-	36.9
Construction Site (Related Project - 144	-	36.4
Mental Health Center	GF	63.0
Construction Site	-	58.3
Construction Site (Related Project - 114	-	25.0
Construction Site (Related Project - 123	-	61.2
Construction Site (Related Project - 136	-	33.9
Construction Site (Related Project - 144	-	29.8
Residences - 6230-40 Lexington Ave.	GF	61.5
Construction Site	-	61.2
Construction Site (Related Project - 114	-	33.0
Construction Site (Related Project - 123	-	48.7
Construction Site (Related Project - 136	-	28.7
Construction Site (Related Project - 144	-	32.2
Residences - 6231-39 Lexington Ave.	GF	61.4
Construction Site	-	61.3
Construction Site (Related Project - 114	-	41.3
Construction Site (Related Project - 123	-	34.5
Construction Site (Related Project - 136	-	28.8
Construction Site (Related Project - 144	-	26.8
Residences - 6232-38 La Mirada Ave.	GF	52.4
Construction Site	-	49.4
Construction Site (Related Project - 114	-	34.2
Construction Site (Related Project - 123	-	49.2
Construction Site (Related Project - 136	-	29.7
Construction Site (Related Project - 144	-	31.1
Taglyan Complex	GF	64.3
Construction Site	-	64.2
Construction Site (Related Project - 114	-	36.9
Construction Site (Related Project - 123	-	45.5
Construction Site (Related Project - 136	-	40.7
Construction Site (Related Project - 144	-	42.5

1200 Vine Street

Signs and symbols

Construction Site

Levels in dB(A)

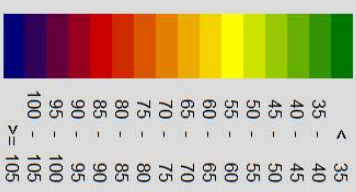

DOUGLASSKIM+ASSOCIATES, LLC

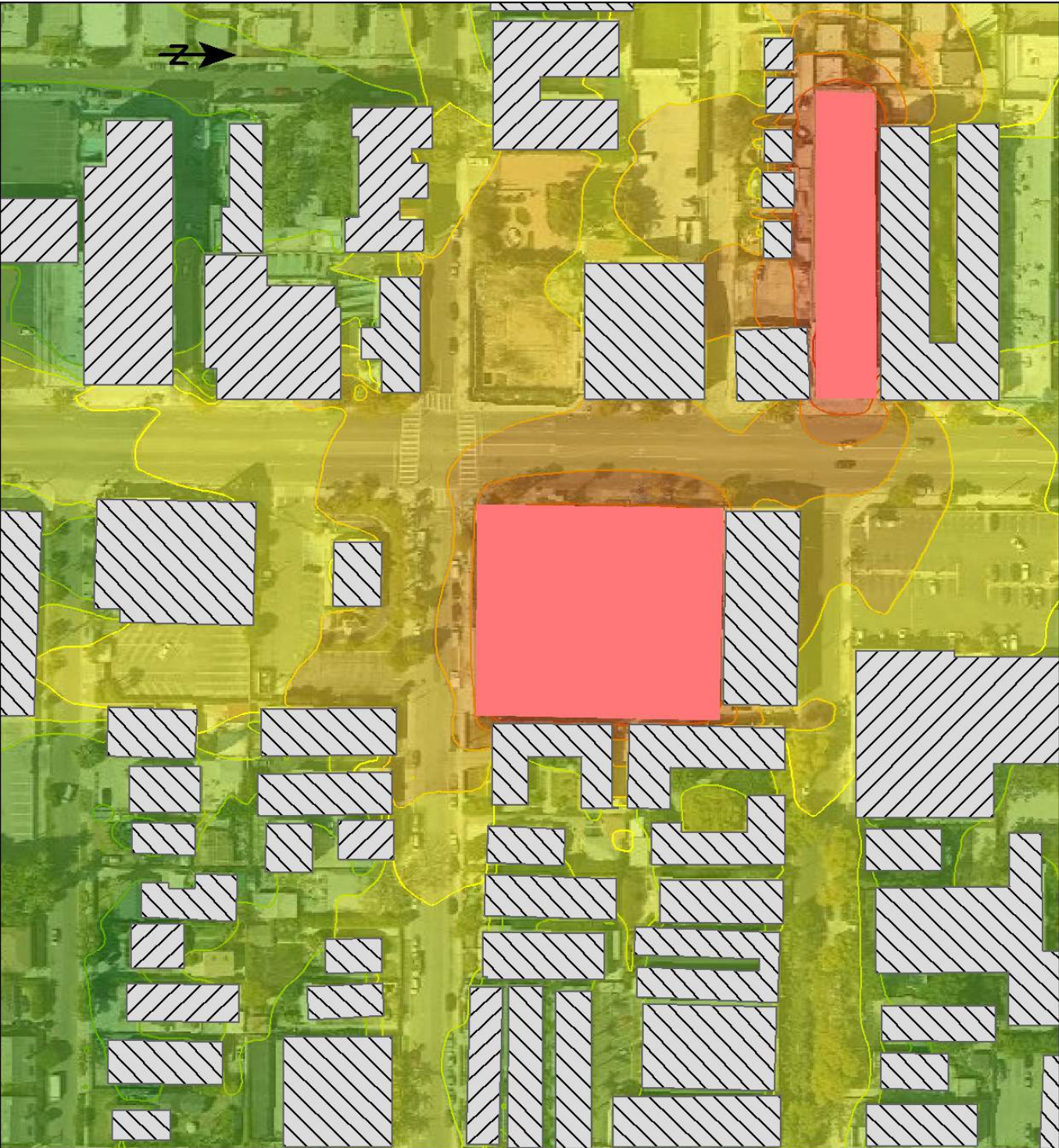

1200 Vine Street

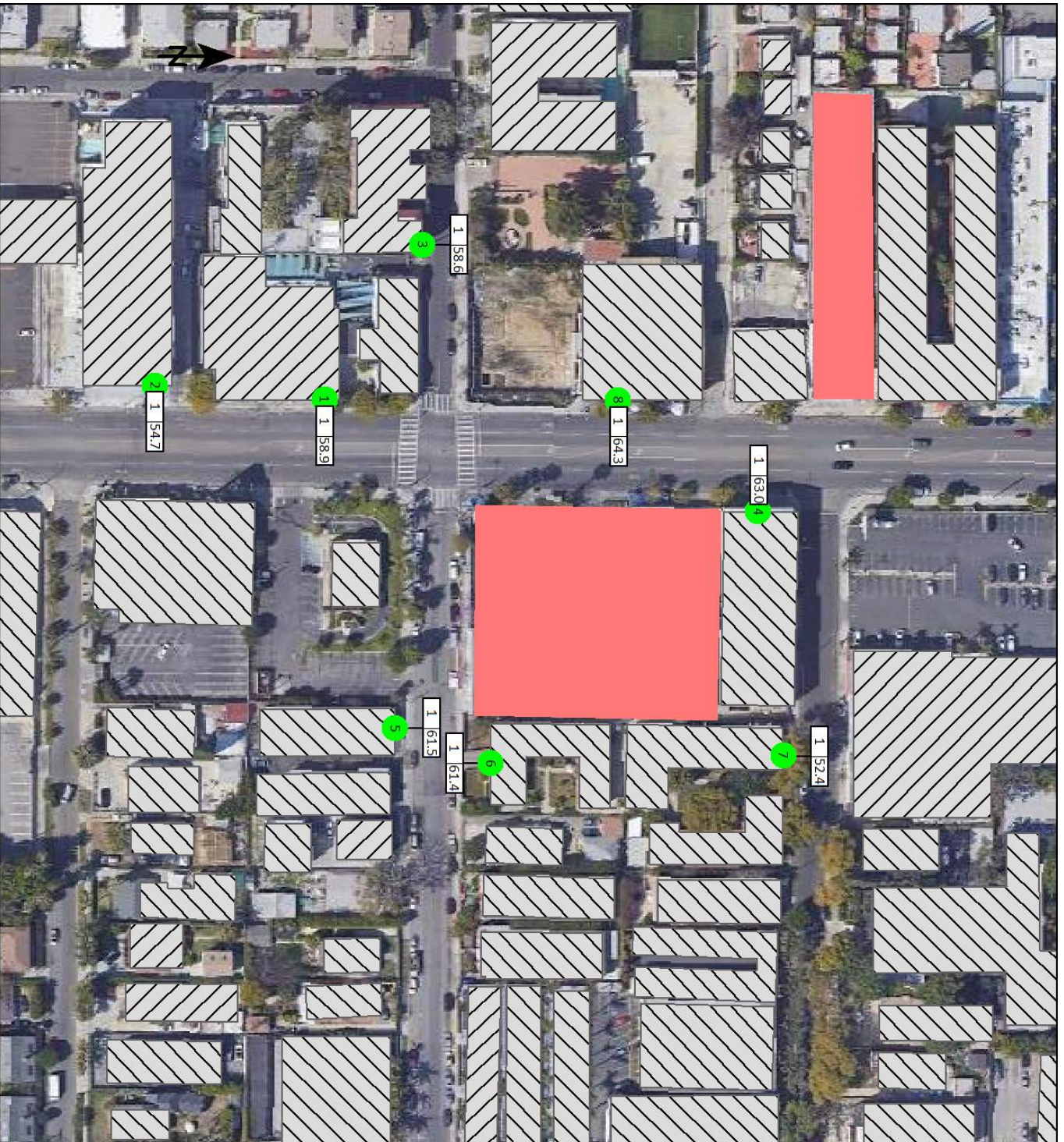

Signs and symbols

-  Analyzed Sensitive Receptor
-  Construction Site



DOUGLASSKIM+ASSOCIATES, LLC

Cumulative Construction Noise Impacts



DOUGLASKIM+ASSOCIATES,LLC

Reference	15.24	meter
Sound Pressure Level (Lp)	75.0	dBA
Sound Power Level (Lw)	109.7	dB

Receptor	Existing Leq	Noise	New Leq	Difference Leq	Significant?
Taglyan Complex	68.1	64.3	69.6	1.5	No
Mental Health Center	68.1	63.0	69.3	1.2	No
Early Head Start School	66.7	58.9	67.4	0.7	No
Residences - 6231-39 Lexington Ave.	59.5	61.4	63.6	4.1	No
Hotel - 1133 Vine St.	66.7	54.7	67.0	0.3	No
Residences - 6230-40 Lexington Ave.	59.5	61.5	63.6	4.1	No
Hotel - 6326 Lexington Ave.	57.6	58.6	61.1	3.5	No
Residences - 6232-38 La Mirada Ave.	59.5	52.4	60.3	0.8	No

Note: Sound Power Level (Lw) assumes full sphere propagation



DOUGLASKIM+ASSOCIATES,LLC

FUTURE EMISSIONS

1200 Vine Street (Future) Detailed Report

Table of Contents

1. Basic Project Information
 - 1.1. Basic Project Information
 - 1.2. Land Use Types
 - 1.3. User-Selected Emission Reduction Measures by Emissions Sector
2. Emissions Summary
 - 2.1. Construction Emissions Compared Against Thresholds
 - 2.2. Construction Emissions by Year, Unmitigated
 - 2.4. Operations Emissions Compared Against Thresholds
 - 2.5. Operations Emissions by Sector, Unmitigated
3. Construction Emissions Details
 - 3.1. Demolition (2024) - Unmitigated
 - 3.3. Grading (2024) - Unmitigated
 - 3.5. Building Construction (2024) - Unmitigated
 - 3.7. Building Construction (2025) - Unmitigated

3.9. Building Construction (2026) - Unmitigated

3.11. Architectural Coating (2026) - Unmitigated

3.13. Trenching (2024) - Unmitigated

4. Operations Emissions Details

4.1. Mobile Emissions by Land Use

4.1.1. Unmitigated

4.2. Energy

4.2.1. Electricity Emissions By Land Use - Unmitigated

4.2.3. Natural Gas Emissions By Land Use - Unmitigated

4.3. Area Emissions by Source

4.3.2. Unmitigated

4.4. Water Emissions by Land Use

4.4.2. Unmitigated

4.5. Waste Emissions by Land Use

4.5.2. Unmitigated

4.6. Refrigerant Emissions by Land Use

4.6.1. Unmitigated

4.7. Offroad Emissions By Equipment Type

4.7.1. Unmitigated

4.8. Stationary Emissions By Equipment Type

4.8.1. Unmitigated

4.9. User Defined Emissions By Equipment Type

4.9.1. Unmitigated

4.10. Soil Carbon Accumulation By Vegetation Type

4.10.1. Soil Carbon Accumulation By Vegetation Type - Unmitigated

4.10.2. Above and Belowground Carbon Accumulation by Land Use Type - Unmitigated

4.10.3. Avoided and Sequestered Emissions by Species - Unmitigated

5. Activity Data

5.1. Construction Schedule

5.2. Off-Road Equipment

5.2.1. Unmitigated

5.3. Construction Vehicles

5.3.1. Unmitigated

5.4. Vehicles

5.4.1. Construction Vehicle Control Strategies

5.5. Architectural Coatings

5.6. Dust Mitigation

5.6.1. Construction Earthmoving Activities

5.6.2. Construction Earthmoving Control Strategies

5.7. Construction Paving

5.8. Construction Electricity Consumption and Emissions Factors

5.9. Operational Mobile Sources

5.9.1. Unmitigated

5.10. Operational Area Sources

5.10.1. Hearths

5.10.1.1. Unmitigated

5.10.2. Architectural Coatings

5.10.3. Landscape Equipment

5.11. Operational Energy Consumption

5.11.1. Unmitigated

5.12. Operational Water and Wastewater Consumption

5.12.1. Unmitigated

5.13. Operational Waste Generation

5.13.1. Unmitigated

5.14. Operational Refrigeration and Air Conditioning Equipment

5.14.1. Unmitigated

5.15. Operational Off-Road Equipment

5.15.1. Unmitigated

5.16. Stationary Sources

5.16.1. Emergency Generators and Fire Pumps

5.16.2. Process Boilers

5.17. User Defined

5.18. Vegetation

5.18.1. Land Use Change

5.18.1.1. Unmitigated

5.18.1. Biomass Cover Type

5.18.1.1. Unmitigated

5.18.2. Sequestration

- 5.18.2.1. Unmitigated
- 6. Climate Risk Detailed Report
 - 6.1. Climate Risk Summary
 - 6.2. Initial Climate Risk Scores
 - 6.3. Adjusted Climate Risk Scores
 - 6.4. Climate Risk Reduction Measures
- 7. Health and Equity Details
 - 7.1. CalEnviroScreen 4.0 Scores
 - 7.2. Healthy Places Index Scores
 - 7.3. Overall Health & Equity Scores
 - 7.4. Health & Equity Measures
 - 7.5. Evaluation Scorecard
 - 7.6. Health & Equity Custom Measures
- 8. User Changes to Default Data

1. Basic Project Information

1.1. Basic Project Information

Data Field	Value
Project Name	1200 Vine Street (Future)
Lead Agency	City of Los Angeles
Land Use Scale	Project/site
Analysis Level for Defaults	County
Windspeed (m/s)	0.50
Precipitation (days)	16.8
Location	1200 Vine St, Los Angeles, CA 90038, USA
County	Los Angeles-South Coast
City	Los Angeles
Air District	South Coast AQMD
Air Basin	South Coast
TAZ	4351
EDFZ	16
Electric Utility	Los Angeles Department of Water & Power
Gas Utility	Southern California Gas

1.2. Land Use Types

Land Use Subtype	Size	Unit	Lot Acreage	Building Area (sq ft)	Landscape Area (sq ft)	Special Landscape Area (sq ft)	Population	Description
Apartments Mid Rise	153	Dwelling Unit	0.90	136,295	2,456	—	361	—
High Turnover (Sit Down Restaurant)	7.00	1000sqft	0.04	7,000	0.00	—	—	—

Enclosed Parking with Elevator	93.0	Space	0.00	37,200	0.00	—	—	—
--------------------------------	------	-------	------	--------	------	---	---	---

1.3. User-Selected Emission Reduction Measures by Emissions Sector

No measures selected

2. Emissions Summary

2.1. Construction Emissions Compared Against Thresholds

Criteria Pollutants (lb/day for daily, ton/yr for annual) and GHGs (lb/day for daily, MT/yr for annual)

Un/Mt.	TOG	ROG	NOx	CO	SO2	PM10E	PM10D	PM10T	PM2.5E	PM2.5D	PM2.5T	BCO2	NBCO2	CO2T	CH4	N2O	R	CO2e
Daily, Summer (Max)	—	—	—	—	—	—	—	—	—	—	—	—	—	—	—	—	—	—
Unmit.	1.78	5.89	17.0	19.2	0.05	0.59	3.41	4.00	0.55	1.36	1.91	—	6,476	6,476	0.31	0.76	11.2	6,723
Daily, Winter (Max)	—	—	—	—	—	—	—	—	—	—	—	—	—	—	—	—	—	—
Unmit.	1.43	5.88	7.26	17.0	0.02	0.27	2.22	2.44	0.25	0.53	0.73	—	4,158	4,158	0.18	0.24	0.24	4,219
Average Daily (Max)	—	—	—	—	—	—	—	—	—	—	—	—	—	—	—	—	—	—
Unmit.	0.95	3.04	6.47	10.9	0.02	0.23	1.38	1.60	0.21	0.39	0.60	—	2,842	2,842	0.13	0.21	2.65	2,911
Annual (Max)	—	—	—	—	—	—	—	—	—	—	—	—	—	—	—	—	—	—
Unmit.	0.17	0.55	1.18	2.00	< 0.005	0.04	0.25	0.29	0.04	0.07	0.11	—	471	471	0.02	0.03	0.44	482

2.2. Construction Emissions by Year, Unmitigated

Criteria Pollutants (lb/day for daily, ton/yr for annual) and GHGs (lb/day for daily, MT/yr for annual)

Year	TOG	ROG	NOx	CO	SO2	PM10E	PM10D	PM10T	PM2.5E	PM2.5D	PM2.5T	BCO2	NBCO2	CO2T	CH4	N2O	R	CO2e
------	-----	-----	-----	----	-----	-------	-------	-------	--------	--------	--------	------	-------	------	-----	-----	---	------

Daily - Summer (Max)	—	—	—	—	—	—	—	—	—	—	—	—	—	—	—	—	—	—	—	—	—	—	—	—
2024	1.78	1.46	17.0	19.2	0.05	0.59	3.41	4.00	0.55	1.36	1.91	—	6,476	6,476	0.31	0.76	11.2	6,723						
2025	1.29	1.09	6.55	16.3	0.02	0.23	1.88	2.11	0.21	0.45	0.66	—	3,833	3,833	0.16	0.18	8.57	3,898						
2026	1.43	5.89	7.07	18.4	0.02	0.22	2.22	2.44	0.20	0.53	0.73	—	4,267	4,267	0.18	0.19	9.07	4,337						
Daily - Winter (Max)	—	—	—	—	—	—	—	—	—	—	—	—	—	—	—	—	—	—						
2024	1.36	1.15	7.26	15.6	0.02	0.27	1.88	2.15	0.25	0.45	0.70	—	3,789	3,789	0.16	0.24	0.24	3,847						
2025	1.28	1.09	6.65	15.0	0.02	0.23	1.88	2.11	0.21	0.45	0.66	—	3,741	3,741	0.16	0.18	0.22	3,799						
2026	1.43	5.88	7.18	17.0	0.02	0.22	2.22	2.44	0.20	0.53	0.73	—	4,158	4,158	0.18	0.19	0.24	4,219						
Average Daily	—	—	—	—	—	—	—	—	—	—	—	—	—	—	—	—	—	—						
2024	0.95	0.77	6.47	9.77	0.02	0.23	1.38	1.60	0.21	0.39	0.60	—	2,842	2,842	0.13	0.21	2.56	2,911						
2025	0.91	0.78	4.79	10.9	0.01	0.16	1.33	1.49	0.15	0.32	0.46	—	2,690	2,690	0.12	0.13	2.65	2,733						
2026	0.62	3.04	3.13	7.52	0.01	0.10	0.95	1.05	0.09	0.23	0.31	—	1,794	1,794	0.08	0.08	1.69	1,822						
Annual	—	—	—	—	—	—	—	—	—	—	—	—	—	—	—	—	—	—						
2024	0.17	0.14	1.18	1.78	< 0.005	0.04	0.25	0.29	0.04	0.07	0.11	—	471	471	0.02	0.03	0.42	482						
2025	0.17	0.14	0.87	2.00	< 0.005	0.03	0.24	0.27	0.03	0.06	0.08	—	445	445	0.02	0.02	0.44	452						
2026	0.11	0.55	0.57	1.37	< 0.005	0.02	0.17	0.19	0.02	0.04	0.06	—	297	297	0.01	0.01	0.28	302						

2.4. Operations Emissions Compared Against Thresholds

Criteria Pollutants (lb/day for daily, ton/yr for annual) and GHGs (lb/day for daily, MT/yr for annual)

Un/mt.	TOG	ROG	NOx	CO	SO2	PM10E	PM10D	PM10T	PM2.5E	PM2.5D	PM2.5T	BCO2	NBCO2	CO2T	CH4	N2O	R	CO2e
Daily, Summer (Max)	—	—	—	—	—	—	—	—	—	—	—	—	—	—	—	—	—	—
Unmit.	4.04	7.05	2.25	28.9	0.04	0.08	1.48	1.55	0.08	0.26	0.34	108	6,615	6,724	11.3	0.23	24.5	7,100

Daily, Winter (Max)	—	—	—	—	—	—	—	—	—	—	—	—	—	—	—	—	—	—	—	—	—
Unmit.	2.87	5.94	2.30	17.2	0.04	0.07	1.48	1.55	0.07	0.26	0.33	108	6,415	6,523	11.3	0.24	12.2	6,890			
Average Daily (Max)	—	—	—	—	—	—	—	—	—	—	—	—	—	—	—	—	—	—	—	—	—
Unmit.	3.63	6.66	2.38	24.8	0.04	0.07	1.48	1.55	0.07	0.26	0.34	108	6,482	6,590	11.3	0.24	17.3	6,962			
Annual (Max)	—	—	—	—	—	—	—	—	—	—	—	—	—	—	—	—	—	—	—	—	—
Unmit.	0.66	1.21	0.43	4.53	0.01	0.01	0.27	0.28	0.01	0.05	0.06	18.0	1,073	1,091	1.87	0.04	2.87	1,153			

2.5. Operations Emissions by Sector, Unmitigated

Criteria Pollutants (lb/day for daily, ton/yr for annual) and GHGs (lb/day for daily, MT/yr for annual)

Sector	TOG	ROG	NOx	CO	SO2	PM10E	PM10D	PM10T	PM2.5E	PM2.5D	PM2.5T	BCO2	NBCO2	CO2T	CH4	N2O	R	CO2e	
Daily, Summer (Max)	—	—	—	—	—	—	—	—	—	—	—	—	—	—	—	—	—	—	—
Mobile	2.83	2.62	1.59	17.9	0.04	0.03	1.48	1.50	0.02	0.26	0.29	—	4,143	4,143	0.23	0.18	12.5	4,214	
Area	1.15	4.40	0.10	10.6	< 0.005	0.01	—	0.01	0.01	—	0.01	0.00	31.1	31.1	< 0.005	< 0.005	—	31.2	
Energy	0.06	0.03	0.56	0.31	< 0.005	0.04	—	0.04	0.04	—	0.04	—	2,340	2,340	0.18	0.02	—	2,350	
Water	—	—	—	—	—	—	—	—	—	—	—	15.0	101	116	1.55	0.04	—	166	
Waste	—	—	—	—	—	—	—	—	—	—	—	93.5	0.00	93.5	9.34	0.00	—	327	
Refrig.	—	—	—	—	—	—	—	—	—	—	—	—	—	—	—	—	11.9	11.9	
Total	4.04	7.05	2.25	28.9	0.04	0.08	1.48	1.55	0.08	0.26	0.34	108	6,615	6,724	11.3	0.23	24.5	7,100	
Daily, Winter (Max)	—	—	—	—	—	—	—	—	—	—	—	—	—	—	—	—	—	—	
Mobile	2.81	2.59	1.74	16.9	0.04	0.03	1.48	1.50	0.02	0.26	0.29	—	3,973	3,973	0.24	0.19	0.32	4,035	
Area	0.00	3.32	0.00	0.00	0.00	0.00	—	0.00	0.00	—	0.00	0.00	0.00	0.00	0.00	0.00	—	0.00	

Energy	0.06	0.03	0.56	0.31	< 0.005	0.04	—	0.04	—	0.04	—	0.04	0.04	—	0.04	0.04	—	0.04	—	0.04	—	2,340	2,340	0.18	0.02	—	2,350	
Water	—	—	—	—	—	—	—	—	—	—	—	—	—	15.0	101	116	1.55	0.04	—	166	—	15.0	101	116	1.55	0.04	—	166
Waste	—	—	—	—	—	—	—	—	—	—	—	—	—	93.5	0.00	93.5	9.34	0.00	—	327	—	93.5	0.00	93.5	9.34	0.00	—	327
Refrig.	—	—	—	—	—	—	—	—	—	—	—	—	—	—	—	—	—	—	—	11.9	—	—	—	—	—	—	11.9	11.9
Total	2.87	5.94	2.30	17.2	0.04	0.07	1.48	1.55	0.07	0.26	0.33	108	6,415	6,523	11.3	0.24	11.3	0.24	12.2	6,890	—	6,415	6,523	11.3	0.24	12.2	6,890	
Average Daily	—	—	—	—	—	—	—	—	—	—	—	—	—	—	—	—	—	—	—	—	—	—	—	—	—	—	—	—
Mobile	2.78	2.57	1.75	17.3	0.04	0.03	1.48	1.50	0.02	0.26	0.29	—	4,019	4,019	0.24	0.19	0.24	0.19	5.41	4,086	—	4,019	4,019	0.24	0.19	5.41	4,086	
Area	0.79	4.06	0.07	7.27	< 0.005	< 0.005	—	< 0.005	0.01	—	0.01	0.00	21.3	21.3	< 0.005	< 0.005	< 0.005	< 0.005	—	21.4	—	21.3	21.3	< 0.005	< 0.005	—	21.4	
Energy	0.06	0.03	0.56	0.31	< 0.005	0.04	—	0.04	0.04	—	0.04	—	2,340	2,340	0.18	0.02	0.02	0.02	—	2,350	—	2,340	2,340	0.18	0.02	—	2,350	
Water	—	—	—	—	—	—	—	—	—	—	—	15.0	101	116	1.55	0.04	0.04	0.04	—	166	—	101	116	1.55	0.04	—	166	
Waste	—	—	—	—	—	—	—	—	—	—	—	93.5	0.00	93.5	9.34	0.00	0.00	0.00	—	327	—	0.00	93.5	9.34	0.00	—	327	
Refrig.	—	—	—	—	—	—	—	—	—	—	—	—	—	—	—	—	—	—	—	11.9	—	—	—	—	—	—	11.9	11.9
Total	3.63	6.66	2.38	24.8	0.04	0.07	1.48	1.55	0.07	0.26	0.34	108	6,482	6,590	11.3	0.24	0.24	0.24	17.3	6,962	—	6,482	6,590	11.3	0.24	17.3	6,962	
Annual	—	—	—	—	—	—	—	—	—	—	—	—	—	—	—	—	—	—	—	—	—	—	—	—	—	—	—	—
Mobile	0.51	0.47	0.32	3.15	0.01	< 0.005	0.27	0.27	< 0.005	0.05	0.05	—	665	665	0.04	0.03	0.03	0.03	0.90	676	—	665	665	0.04	0.03	0.90	676	
Area	0.14	0.74	0.01	1.33	< 0.005	< 0.005	—	< 0.005	< 0.005	—	< 0.005	0.00	3.53	3.53	< 0.005	< 0.005	< 0.005	< 0.005	—	3.54	—	3.53	3.53	< 0.005	< 0.005	—	3.54	
Energy	0.01	0.01	0.10	0.06	< 0.005	0.01	—	0.01	0.01	—	0.01	—	387	387	0.03	< 0.005	< 0.005	< 0.005	—	389	—	387	387	0.03	< 0.005	—	389	
Water	—	—	—	—	—	—	—	—	—	—	—	2.48	16.8	19.2	0.26	0.01	0.01	0.01	—	27.5	—	16.8	19.2	0.26	0.01	—	27.5	
Waste	—	—	—	—	—	—	—	—	—	—	—	15.5	0.00	15.5	1.55	0.00	0.00	0.00	—	54.2	—	0.00	15.5	1.55	0.00	—	54.2	
Refrig.	—	—	—	—	—	—	—	—	—	—	—	—	—	—	—	—	—	—	1.97	1.97	—	—	—	—	—	—	1.97	1.97
Total	0.66	1.21	0.43	4.53	0.01	0.01	0.27	0.28	0.01	0.05	0.06	18.0	1,073	1,091	1.87	0.04	0.04	0.04	2.87	1,153	—	1,073	1,091	1.87	0.04	2.87	1,153	

3. Construction Emissions Details

3.1. Demolition (2024) - Unmitigated

Criteria Pollutants (lb/day for daily, ton/yr for annual) and GHGs (lb/day for daily, MT/yr for annual)

1200 Vine Street (Future) Detailed Report, 10/9/2022

Location	TOG	ROG	NOx	CO	SO2	PM10E	PM10D	PM10T	PM2.5E	PM2.5D	PM2.5T	BCO2	NBCO2	CO2T	CH4	N2O	R	CO2e
Onsite	—	—	—	—	—	—	—	—	—	—	—	—	—	—	—	—	—	—
Daily, Summer (Max)	—	—	—	—	—	—	—	—	—	—	—	—	—	—	—	—	—	—
Daily, Winter (Max)	—	—	—	—	—	—	—	—	—	—	—	—	—	—	—	—	—	—
Off-Road Equipment	0.61	0.51	4.69	5.79	0.01	0.19	—	0.19	0.17	—	0.17	—	852	852	0.03	0.01	—	855
Demolition	—	—	—	—	—	—	0.48	0.48	—	0.07	0.07	—	—	—	—	—	—	—
Onsite truck	0.00	0.00	0.00	0.00	0.00	0.00	0.00	0.00	0.00	0.00	0.00	—	0.00	0.00	0.00	0.00	0.00	0.00
Average Daily	—	—	—	—	—	—	—	—	—	—	—	—	—	—	—	—	—	—
Off-Road Equipment	0.11	0.09	0.82	1.01	< 0.005	0.03	—	0.03	0.03	—	0.03	—	149	149	0.01	< 0.005	—	150
Demolition	—	—	—	—	—	—	0.08	0.08	—	0.01	0.01	—	—	—	—	—	—	—
Onsite truck	0.00	0.00	0.00	0.00	0.00	0.00	0.00	0.00	0.00	0.00	0.00	—	0.00	0.00	0.00	0.00	0.00	0.00
Annual	—	—	—	—	—	—	—	—	—	—	—	—	—	—	—	—	—	—
Off-Road Equipment	0.02	0.02	0.15	0.19	< 0.005	0.01	—	0.01	0.01	—	0.01	—	24.7	24.7	< 0.005	< 0.005	—	24.8
Demolition	—	—	—	—	—	—	0.02	0.02	—	< 0.005	< 0.005	—	—	—	—	—	—	—
Onsite truck	0.00	0.00	0.00	0.00	0.00	0.00	0.00	0.00	0.00	0.00	0.00	—	0.00	0.00	0.00	0.00	0.00	0.00
Offsite	—	—	—	—	—	—	—	—	—	—	—	—	—	—	—	—	—	—
Daily, Summer (Max)	—	—	—	—	—	—	—	—	—	—	—	—	—	—	—	—	—	—

Daily, Winter (Max)	—	—	—	—	—	—	—	—	—	—	—	—	—	—	—	—	—	—	—	—	—			
Worker	0.05	0.04	0.06	0.64	0.00	0.00	0.01	0.01	0.00	0.00	0.00	0.00	0.00	0.00	0.00	0.00	0.00	—	134	134	0.01	< 0.005	0.01	0.135
Vendor	0.00	0.00	0.00	0.00	0.00	0.00	0.00	0.00	0.00	0.00	0.00	0.00	0.00	0.00	0.00	0.00	0.00	—	0.00	0.00	0.00	0.00	0.00	0.00
Hauling	0.10	0.03	1.73	0.60	0.01	0.02	0.11	0.12	0.02	0.12	0.04	0.05	0.05	—	1,395	1,395	0.07	0.22	0.08	0.08	1,464			
Average Daily	—	—	—	—	—	—	—	—	—	—	—	—	—	—	—	—	—	—	—	—	—			
Worker	0.01	0.01	0.01	0.12	0.00	0.00	< 0.005	< 0.005	< 0.005	0.00	0.00	0.00	0.00	—	23.8	23.8	< 0.005	< 0.005	0.04	0.04	24.1			
Vendor	0.00	0.00	0.00	0.00	0.00	0.00	0.00	0.00	0.00	0.00	0.00	0.00	0.00	—	0.00	0.00	0.00	0.00	0.00	0.00	0.00			
Hauling	0.02	< 0.005	0.31	0.11	< 0.005	< 0.005	0.02	0.02	< 0.005	0.01	0.01	—	245	245	0.01	0.04	0.24	257						
Annual	—	—	—	—	—	—	—	—	—	—	—	—	—	—	—	—	—	—	—	—				
Worker	< 0.005	< 0.005	< 0.005	0.02	0.00	0.00	< 0.005	< 0.005	< 0.005	0.00	0.00	0.00	0.00	—	3.94	3.94	< 0.005	< 0.005	0.01	4.00				
Vendor	0.00	0.00	0.00	0.00	0.00	0.00	0.00	0.00	0.00	0.00	0.00	0.00	0.00	—	0.00	0.00	0.00	0.00	0.00	0.00				
Hauling	< 0.005	< 0.005	0.06	0.02	< 0.005	< 0.005	< 0.005	< 0.005	< 0.005	< 0.005	< 0.005	< 0.005	< 0.005	—	40.5	40.5	< 0.005	0.01	0.04	42.5				

3.3. Grading (2024) - Unmitigated

Criteria Pollutants (lb/day for daily, ton/yr for annual) and GHGs (lb/day for daily, MT/yr for annual)

Location	TOG	ROG	NOx	CO	SO2	PM10E	PM10D	PM10T	PM2.5E	PM2.5D	PM2.5T	BCO2	NBCO2	CO2T	CH4	N2O	R	CO2e
Onsite	—	—	—	—	—	—	—	—	—	—	—	—	—	—	—	—	—	—
Daily, Summer (Max)	—	—	—	—	—	—	—	—	—	—	—	—	—	—	—	—	—	—
Off-Road Equipment	1.41	1.19	11.4	10.7	0.02	0.53	—	0.53	0.49	—	0.49	—	1,713	1,713	0.07	0.01	—	1,719
Dust From Material Movement:	—	—	—	—	—	—	2.07	2.07	—	1.00	1.00	—	—	—	—	—	—	—
Onsite truck	0.00	0.00	0.00	0.00	0.00	0.00	0.00	0.00	0.00	0.00	0.00	—	0.00	0.00	0.00	0.00	0.00	0.00

1200 Vine Street (Future) Detailed Report, 10/9/2022

Daily, Winter (Max)	—	—	—	—	—	—	—	—	—	—	—	—	—	—	—	—	—	—	—	—	—	—	—	—	—	—	—	—	—	—	—	—	—	—	—	—	—	—	—	—	—	—								
Average Daily	—	—	—	—	—	—	—	—	—	—	—	—	—	—	—	—	—	—	—	—	—	—	—	—	—	—	—	—	—	—	—	—	—	—	—	—	—	—	—	—	—	—	—	—	—	—	—	—	—	
Off-Road Equipment	0.17	0.15	1.40	1.32	< 0.005	0.07	—	0.07	0.06	—	0.06	—	0.06	—	211	211	0.01	< 0.005	—	212																														
Dust From Material Movement:	—	—	—	—	—	—	0.26	0.26	—	0.12	0.12	—	—	—	—	—	—	—	—	—	—	—	—	—	—	—	—	—	—	—	—	—	—	—	—	—	—	—	—	—	—	—	—	—	—	—	—	—		
Onsite truck	0.00	0.00	0.00	0.00	0.00	0.00	0.00	0.00	0.00	0.00	0.00	—	0.00	0.00	0.00	0.00	0.00	0.00	0.00	0.00	0.00																													
Annual	—	—	—	—	—	—	—	—	—	—	—	—	—	—	—	—	—	—	—	—	—																													
Off-Road Equipment	0.03	0.03	0.26	0.24	< 0.005	0.01	—	0.01	0.01	—	0.01	—	0.01	—	35.0	35.0	< 0.005	< 0.005	—	35.1																														
Dust From Material Movement:	—	—	—	—	—	—	0.05	0.05	—	0.02	0.02	—	—	—	—	—	—	—	—	—	—																													
Onsite truck	0.00	0.00	0.00	0.00	0.00	0.00	0.00	0.00	0.00	0.00	0.00	—	0.00	0.00	0.00	0.00	0.00	0.00	0.00	0.00	0.00	0.00	0.00	0.00	0.00	0.00	0.00	0.00	0.00	0.00	0.00	0.00	0.00	0.00	0.00	0.00	0.00	0.00	0.00	0.00	0.00	0.00	0.00	0.00	0.00	0.00				
Offsite	—	—	—	—	—	—	—	—	—	—	—	—	—	—	—	—	—	—	—	—	—																													
Daily, Summer (Max)	—	—	—	—	—	—	—	—	—	—	—	—	—	—	—	—	—	—	—	—	—	—	—	—	—	—	—	—	—	—	—	—	—	—	—	—	—	—	—	—	—	—	—	—	—	—	—	—		
Worker	0.04	0.03	0.04	0.57	0.00	0.00	0.01	0.01	0.00	0.00	0.00	—	106	106	< 0.005	< 0.005	0.42	107																																
Vendor	0.00	0.00	0.00	0.00	0.00	0.00	0.00	0.00	0.00	0.00	0.00	—	0.00	0.00	0.00	0.00	0.00	0.00	0.00	0.00																														
Hauling	0.33	0.09	5.56	2.03	0.03	0.06	0.35	0.41	0.06	0.12	0.18	—	4,657	4,657	0.24	0.75	10.8	4,897																																
Daily, Winter (Max)	—	—	—	—	—	—	—	—	—	—	—	—	—	—	—	—	—	—	—	—	—	—	—	—	—	—	—	—	—	—	—	—	—	—	—	—	—	—	—	—	—	—	—	—	—	—	—	—	—	—
Average Daily	—	—	—	—	—	—	—	—	—	—	—	—	—	—	—	—	—	—	—	—	—																													

Worker	< 0.005	< 0.005	0.01	0.06	0.00	0.00	< 0.005	< 0.005	0.00	0.00	< 0.005	< 0.005	0.00	0.00	—	12.6	12.6	< 0.005	< 0.005	0.02	12.7	
Vendor	0.00	0.00	0.00	0.00	0.00	0.00	0.00	0.00	0.00	0.00	0.00	0.00	0.00	0.00	—	0.00	0.00	0.00	0.00	0.00	0.00	0.00
Hauling	0.04	0.01	0.72	0.25	< 0.005	0.01	0.04	0.05	0.01	0.01	0.02	0.02	0.03	0.09	0.57	574	574	0.03	0.09	0.57	603	
Annual	—	—	—	—	—	—	—	—	—	—	—	—	—	—	—	—	—	—	—	—	—	
Worker	< 0.005	< 0.005	< 0.005	0.01	0.00	0.00	< 0.005	< 0.005	< 0.005	0.00	0.00	0.00	< 0.005	< 0.005	< 0.005	2.08	2.08	< 0.005	< 0.005	< 0.005	2.11	
Vendor	0.00	0.00	0.00	0.00	0.00	0.00	0.00	0.00	0.00	0.00	0.00	0.00	0.00	0.00	—	0.00	0.00	0.00	0.00	0.00	0.00	
Hauling	0.01	< 0.005	0.13	0.05	< 0.005	< 0.005	0.01	0.01	< 0.005	< 0.005	< 0.005	< 0.005	< 0.005	0.02	0.10	95.1	95.1	< 0.005	0.02	0.10	99.8	

3.5. Building Construction (2024) - Unmitigated

Criteria Pollutants (lb/day for daily, ton/yr for annual) and GHGs (lb/day for daily, MT/yr for annual)

Location	TOG	FOG	NOx	CO	SO2	PM10E	PM10D	PM10T	PM2.5E	PM2.5D	PM2.5T	BCO2	NBCO2	CO2T	CH4	N2O	R	CO2e
Onsite	—	—	—	—	—	—	—	—	—	—	—	—	—	—	—	—	—	—
Daily, Summer (Max)	—	—	—	—	—	—	—	—	—	—	—	—	—	—	—	—	—	—
Off-Road Equipment	0.67	0.56	5.60	6.98	0.01	0.26	—	0.26	0.23	—	0.23	—	1,305	1,305	0.05	0.01	—	1,309
Onsite truck	0.00	0.00	0.00	0.00	0.00	0.00	0.00	0.00	0.00	0.00	0.00	—	0.00	0.00	0.00	0.00	0.00	0.00
Daily, Winter (Max)	—	—	—	—	—	—	—	—	—	—	—	—	—	—	—	—	—	—
Off-Road Equipment	0.67	0.56	5.60	6.98	0.01	0.26	—	0.26	0.23	—	0.23	—	1,305	1,305	0.05	0.01	—	1,309
Onsite truck	0.00	0.00	0.00	0.00	0.00	0.00	0.00	0.00	0.00	0.00	0.00	—	0.00	0.00	0.00	0.00	0.00	0.00
Average Daily	—	—	—	—	—	—	—	—	—	—	—	—	—	—	—	—	—	—
Off-Road Equipment	0.28	0.23	2.34	2.92	0.01	0.11	—	0.11	0.10	—	0.10	—	546	546	0.02	< 0.005	—	548

3.7. Building Construction (2025) - Unmitigated

Criteria Pollutants (lb/day for daily, ton/yr for annual) and GHGs (lb/day for daily, MT/yr for annual)

Location	TOG	ROG	NOx	CO	SO2	PM10E	PM10D	PM10T	PM2.5E	PM2.5D	PM2.5T	BCO2	NBCO2	CO2T	CH4	N2O	R	CO2e
Onsite	—	—	—	—	—	—	—	—	—	—	—	—	—	—	—	—	—	—
Daily, Summer (Max)	—	—	—	—	—	—	—	—	—	—	—	—	—	—	—	—	—	—
Off-Road Equipment	0.62	0.52	5.14	6.94	0.01	0.22	—	0.22	0.20	—	0.20	—	1,305	1,305	0.05	0.01	—	1,309
Onsite truck	0.00	0.00	0.00	0.00	0.00	0.00	0.00	0.00	0.00	0.00	0.00	—	0.00	0.00	0.00	0.00	0.00	0.00
Daily, Winter (Max)	—	—	—	—	—	—	—	—	—	—	—	—	—	—	—	—	—	—
Off-Road Equipment	0.62	0.52	5.14	6.94	0.01	0.22	—	0.22	0.20	—	0.20	—	1,305	1,305	0.05	0.01	—	1,309
Onsite truck	0.00	0.00	0.00	0.00	0.00	0.00	0.00	0.00	0.00	0.00	0.00	—	0.00	0.00	0.00	0.00	0.00	0.00
Average Daily	—	—	—	—	—	—	—	—	—	—	—	—	—	—	—	—	—	—
Off-Road Equipment	0.44	0.37	3.67	4.96	0.01	0.16	—	0.16	0.14	—	0.14	—	932	932	0.04	0.01	—	935
Onsite truck	0.00	0.00	0.00	0.00	0.00	0.00	0.00	0.00	0.00	0.00	0.00	—	0.00	0.00	0.00	0.00	0.00	0.00
Annual	—	—	—	—	—	—	—	—	—	—	—	—	—	—	—	—	—	—
Off-Road Equipment	0.08	0.07	0.67	0.90	< 0.005	0.03	—	0.03	0.03	—	0.03	—	154	154	0.01	< 0.005	—	155
Onsite truck	0.00	0.00	0.00	0.00	0.00	0.00	0.00	0.00	0.00	0.00	0.00	—	0.00	0.00	0.00	0.00	0.00	0.00
Offsite	—	—	—	—	—	—	—	—	—	—	—	—	—	—	—	—	—	—

Daily, Summer (Max)	—	—	—	—	—	—	—	—	—	—	—	—	—	—	—	—	—	—	—	—	—	—	—	—	—	—		
Worker	0.62	0.55	0.56	8.96	0.00	0.00	0.11	0.11	0.11	0.00	0.00	0.00	0.00	0.00	0.00	0.00	0.00	0.00	0.00	0.00	0.00	1,780	1,780	0.08	0.06	6.52	1,806	
Vendor	0.05	0.02	0.85	0.42	0.01	0.01	0.04	0.04	0.05	0.01	0.02	0.02	0.02	0.02	—	—	749	749	0.03	0.10	2.05	783	783	0.03	0.10	2.05	783	
Hauling	0.00	0.00	0.00	0.00	0.00	0.00	0.00	0.00	0.00	0.00	0.00	0.00	0.00	0.00	—	—	0.00	0.00	0.00	0.00	0.00	0.00	0.00	0.00	0.00	0.00	0.00	0.00
Daily, Winter (Max)	—	—	—	—	—	—	—	—	—	—	—	—	—	—	—	—	—	—	—	—	—	—	—	—	—	—	—	—
Worker	0.61	0.55	0.62	7.59	0.00	0.00	0.11	0.11	0.11	0.00	0.00	0.00	0.00	0.00	—	—	1,687	1,687	0.08	0.06	0.17	1,708	1,708	0.08	0.06	0.17	1,708	
Vendor	0.05	0.02	0.89	0.42	0.01	0.01	0.04	0.04	0.05	0.01	0.02	0.02	0.02	0.02	—	—	749	749	0.03	0.10	0.05	781	781	0.03	0.10	0.05	781	
Hauling	0.00	0.00	0.00	0.00	0.00	0.00	0.00	0.00	0.00	0.00	0.00	0.00	0.00	0.00	—	—	0.00	0.00	0.00	0.00	0.00	0.00	0.00	0.00	0.00	0.00	0.00	0.00
Average Daily	—	—	—	—	—	—	—	—	—	—	—	—	—	—	—	—	—	—	—	—	—	—	—	—	—	—	—	—
Worker	0.43	0.39	0.48	5.70	0.00	0.00	0.08	0.08	0.08	0.00	0.00	0.00	0.00	0.00	—	—	1,223	1,223	0.06	0.04	2.01	1,239	1,239	0.06	0.04	2.01	1,239	
Vendor	0.04	0.02	0.64	0.30	< 0.005	0.01	0.03	0.03	0.04	0.01	0.01	< 0.005	0.01	0.02	—	—	535	535	0.02	0.07	0.63	558	558	0.02	0.07	0.63	558	
Hauling	0.00	0.00	0.00	0.00	0.00	0.00	0.00	0.00	0.00	0.00	0.00	0.00	0.00	0.00	—	—	0.00	0.00	0.00	0.00	0.00	0.00	0.00	0.00	0.00	0.00	0.00	0.00
Annual	—	—	—	—	—	—	—	—	—	—	—	—	—	—	—	—	—	—	—	—	—	—	—	—	—	—	—	—
Worker	0.08	0.07	0.09	1.04	0.00	0.00	0.01	0.01	0.01	0.01	0.00	0.00	0.00	0.00	—	—	202	202	0.01	0.01	0.33	205	205	0.01	0.01	0.33	205	
Vendor	0.01	< 0.005	0.12	0.05	< 0.005	< 0.005	0.01	0.01	0.01	0.01	< 0.005	< 0.005	< 0.005	< 0.005	—	—	88.6	88.6	< 0.005	0.01	0.11	92.5	92.5	< 0.005	0.01	0.11	92.5	
Hauling	0.00	0.00	0.00	0.00	0.00	0.00	0.00	0.00	0.00	0.00	0.00	0.00	0.00	0.00	—	—	0.00	0.00	0.00	0.00	0.00	0.00	0.00	0.00	0.00	0.00	0.00	0.00

3.9. Building Construction (2026) - Unmitigated

Criteria Pollutants (lb/day for daily, ton/yr for annual) and GHGs (lb/day for daily, MT/yr for annual)

Location	TOG	ROG	NOx	CO	SO2	PM10E	PM10D	PM10T	PM2.5E	PM2.5D	PM2.5T	BCO2	NBCO2	CO2T	CH4	N2O	R	CO2e	
Onsite	—	—	—	—	—	—	—	—	—	—	—	—	—	—	—	—	—	—	—
Daily, Summer (Max)	—	—	—	—	—	—	—	—	—	—	—	—	—	—	—	—	—	—	—

1200 Vine Street (Future) Detailed Report, 10/9/2022

Off-Road Equipment	0.59	0.49	4.81	6.91	0.01	0.19	—	0.19	0.17	—	0.17	—	1,304	1,304	0.05	0.01	—	1,309
Onsite truck	0.00	0.00	0.00	0.00	0.00	0.00	0.00	0.00	0.00	0.00	0.00	—	0.00	0.00	0.00	0.00	0.00	0.00
Daily, Winter (Max)	—	—	—	—	—	—	—	—	—	—	—	—	—	—	—	—	—	—
Off-Road Equipment	0.59	0.49	4.81	6.91	0.01	0.19	—	0.19	0.17	—	0.17	—	1,304	1,304	0.05	0.01	—	1,309
Onsite truck	0.00	0.00	0.00	0.00	0.00	0.00	0.00	0.00	0.00	0.00	0.00	—	0.00	0.00	0.00	0.00	0.00	0.00
Average Daily	—	—	—	—	—	—	—	—	—	—	—	—	—	—	—	—	—	—
Off-Road Equipment	0.24	0.20	1.99	2.86	< 0.005	0.08	—	0.08	0.07	—	0.07	—	541	541	0.02	< 0.005	—	543
Onsite truck	0.00	0.00	0.00	0.00	0.00	0.00	0.00	0.00	0.00	0.00	0.00	—	0.00	0.00	0.00	0.00	0.00	0.00
Annual	—	—	—	—	—	—	—	—	—	—	—	—	—	—	—	—	—	—
Off-Road Equipment	0.04	0.04	0.36	0.52	< 0.005	0.01	—	0.01	0.01	—	0.01	—	89.6	89.6	< 0.005	< 0.005	—	89.9
Onsite truck	0.00	0.00	0.00	0.00	0.00	0.00	0.00	0.00	0.00	0.00	0.00	—	0.00	0.00	0.00	0.00	0.00	0.00
Offsite	—	—	—	—	—	—	—	—	—	—	—	—	—	—	—	—	—	—
Daily, Summer (Max)	—	—	—	—	—	—	—	—	—	—	—	—	—	—	—	—	—	—
Worker	0.53	0.47	0.50	8.31	0.00	0.00	0.11	0.11	0.00	0.00	0.00	—	1,744	1,744	0.07	0.06	5.90	1,770
Vendor	0.05	0.02	0.81	0.39	0.01	0.01	0.04	0.05	0.01	0.02	0.02	—	736	736	0.03	0.10	1.99	770
Hauling	0.00	0.00	0.00	0.00	0.00	0.00	0.00	0.00	0.00	0.00	0.00	—	0.00	0.00	0.00	0.00	0.00	0.00
Daily, Winter (Max)	—	—	—	—	—	—	—	—	—	—	—	—	—	—	—	—	—	—
Worker	0.53	0.47	0.56	7.09	0.00	0.00	0.11	0.11	0.00	0.00	0.00	—	1,653	1,653	0.08	0.06	0.15	1,674

Vendor	0.05	0.02	0.85	0.40	0.01	0.01	0.04	0.05	0.01	0.02	0.02	—	736	736	0.03	0.10	0.05	768
Hauling	0.00	0.00	0.00	0.00	0.00	0.00	0.00	0.00	0.00	0.00	0.00	—	0.00	0.00	0.00	0.00	0.00	0.00
Average Daily	—	—	—	—	—	—	—	—	—	—	—	—	—	—	—	—	—	—
Worker	0.22	0.19	0.25	3.08	0.00	0.00	0.04	0.04	0.04	0.04	0.00	—	696	696	0.03	0.03	1.06	705
Vendor	0.02	0.01	0.35	0.16	< 0.005	< 0.005	0.02	0.02	0.02	< 0.005	0.01	—	305	305	0.01	0.04	0.36	319
Hauling	0.00	0.00	0.00	0.00	0.00	0.00	0.00	0.00	0.00	0.00	0.00	—	0.00	0.00	0.00	0.00	0.00	0.00
Annual	—	—	—	—	—	—	—	—	—	—	—	—	—	—	—	—	—	—
Worker	0.04	0.04	0.05	0.56	0.00	0.00	0.01	0.01	0.01	0.00	0.00	—	115	115	0.01	< 0.005	0.18	117
Vendor	< 0.005	< 0.005	0.06	0.03	< 0.005	< 0.005	< 0.005	< 0.005	< 0.005	< 0.005	< 0.005	—	50.5	50.5	< 0.005	0.01	0.06	52.8
Hauling	0.00	0.00	0.00	0.00	0.00	0.00	0.00	0.00	0.00	0.00	0.00	—	0.00	0.00	0.00	0.00	0.00	0.00

3.1.1. Architectural Coating (2026) - Unmitigated

Criteria Pollutants (lb/day for daily, ton/yr for annual) and GHGs (lb/day for daily, MT/yr for annual)

Location	TOG	ROG	NOx	CO	SO2	PM10E	PM10D	PM10T	PM2.5E	PM2.5D	PM2.5T	BCO2	NBCO2	CO2T	CH4	N2O	R	CO2e	
Onsite	—	—	—	—	—	—	—	—	—	—	—	—	—	—	—	—	—	—	—
Daily, Summer (Max)	—	—	—	—	—	—	—	—	—	—	—	—	—	—	—	—	—	—	—
Off-Road Equipment	0.15	0.12	0.86	1.13	< 0.005	0.02	—	0.02	0.02	—	0.02	—	134	134	0.01	< 0.005	—	134	
Architectural Coatings	—	4.68	—	—	—	—	—	—	—	—	—	—	—	—	—	—	—	—	—
Onsite truck	0.00	0.00	0.00	0.00	0.00	0.00	0.00	0.00	0.00	0.00	0.00	—	0.00	0.00	0.00	0.00	0.00	0.00	
Daily, Winter (Max)	—	—	—	—	—	—	—	—	—	—	—	—	—	—	—	—	—	—	—
Off-Road Equipment	0.15	0.12	0.86	1.13	< 0.005	0.02	—	0.02	0.02	—	0.02	—	134	134	0.01	< 0.005	—	134	

1200 Vine Street (Future) Detailed Report, 10/9/2022

Architect Coatings	—	4.68	—	—	—	—	—	—	—	—	—	—	—	—	—	—	—	—	—		
Onsite truck	0.00	0.00	0.00	0.00	0.00	0.00	0.00	0.00	0.00	0.00	0.00	0.00	0.00	0.00	—	0.00	0.00	0.00	0.00	0.00	
Average Daily	—	—	—	—	—	—	—	—	—	—	—	—	—	—	—	—	—	—	—	—	
Off-Road Equipment	0.08	0.06	0.46	0.61	< 0.005	0.01	—	0.01	0.01	—	0.01	—	0.01	—	—	71.7	71.7	< 0.005	< 0.005	—	71.9
Architectural Coatings	—	2.52	—	—	—	—	—	—	—	—	—	—	—	—	—	—	—	—	—	—	—
Onsite truck	0.00	0.00	0.00	0.00	0.00	0.00	0.00	0.00	0.00	0.00	0.00	0.00	0.00	0.00	—	0.00	0.00	0.00	0.00	0.00	0.00
Annual	—	—	—	—	—	—	—	—	—	—	—	—	—	—	—	—	—	—	—	—	—
Off-Road Equipment	0.01	0.01	0.08	0.11	< 0.005	< 0.005	—	< 0.005	< 0.005	—	< 0.005	—	< 0.005	—	—	11.9	11.9	< 0.005	< 0.005	—	11.9
Architectural Coatings	—	0.46	—	—	—	—	—	—	—	—	—	—	—	—	—	—	—	—	—	—	—
Onsite truck	0.00	0.00	0.00	0.00	0.00	0.00	0.00	0.00	0.00	0.00	0.00	0.00	0.00	0.00	—	0.00	0.00	0.00	0.00	0.00	0.00
Offsite	—	—	—	—	—	—	—	—	—	—	—	—	—	—	—	—	—	—	—	—	—
Daily, Summer (Max)	—	—	—	—	—	—	—	—	—	—	—	—	—	—	—	—	—	—	—	—	—
Worker	0.11	0.09	0.10	1.66	0.00	0.00	0.02	0.00	0.00	0.02	0.00	0.00	0.00	0.00	—	349	349	0.01	0.01	1.18	354
Vendor	0.00	0.00	0.00	0.00	0.00	0.00	0.00	0.00	0.00	0.00	0.00	0.00	0.00	0.00	—	0.00	0.00	0.00	0.00	0.00	0.00
Hauling	0.00	0.00	0.00	0.00	0.00	0.00	0.00	0.00	0.00	0.00	0.00	0.00	0.00	0.00	—	0.00	0.00	0.00	0.00	0.00	0.00
Daily, Winter (Max)	—	—	—	—	—	—	—	—	—	—	—	—	—	—	—	—	—	—	—	—	—
Worker	0.11	0.09	0.11	1.42	0.00	0.00	0.02	0.00	0.00	0.02	0.00	0.00	0.00	0.00	—	331	331	0.02	0.01	0.03	335
Vendor	0.00	0.00	0.00	0.00	0.00	0.00	0.00	0.00	0.00	0.00	0.00	0.00	0.00	0.00	—	0.00	0.00	0.00	0.00	0.00	0.00

Hauling	0.00	0.00	0.00	0.00	0.00	0.00	0.00	0.00	0.00	0.00	0.00	0.00	0.00	0.00	0.00	0.00	0.00	0.00	0.00	0.00	0.00	0.00	0.00
Average Daily	—	—	—	—	—	—	—	—	—	—	—	—	—	—	—	—	—	—	—	—	—	—	—
Worker	0.06	0.05	0.07	0.80	0.00	0.00	0.01	0.01	0.00	0.00	0.00	0.00	0.00	0.00	0.00	0.00	0.00	0.00	0.00	0.00	0.00	0.00	0.27
Vendor	0.00	0.00	0.00	0.00	0.00	0.00	0.00	0.00	0.00	0.00	0.00	0.00	0.00	0.00	0.00	0.00	0.00	0.00	0.00	0.00	0.00	0.00	0.00
Hauling	0.00	0.00	0.00	0.00	0.00	0.00	0.00	0.00	0.00	0.00	0.00	0.00	0.00	0.00	0.00	0.00	0.00	0.00	0.00	0.00	0.00	0.00	0.00
Annual	—	—	—	—	—	—	—	—	—	—	—	—	—	—	—	—	—	—	—	—	—	—	—
Worker	0.01	0.01	0.01	0.15	0.00	0.00	0.00	0.00	< 0.005	< 0.005	0.00	0.00	0.00	0.00	0.00	0.00	0.00	0.00	0.00	0.00	0.00	0.05	30.2
Vendor	0.00	0.00	0.00	0.00	0.00	0.00	0.00	0.00	0.00	0.00	0.00	0.00	0.00	0.00	0.00	0.00	0.00	0.00	0.00	0.00	0.00	0.00	0.00
Hauling	0.00	0.00	0.00	0.00	0.00	0.00	0.00	0.00	0.00	0.00	0.00	0.00	0.00	0.00	0.00	0.00	0.00	0.00	0.00	0.00	0.00	0.00	0.00

3.13. Trenching (2024) - Unmitigated

Criteria Pollutants (lb/day for daily, ton/yr for annual) and GHGs (lb/day for daily, MT/yr for annual)																							
Location	TOG	ROG	NOx	CO	SO2	PM10E	PM10D	PM10T	PM2.5E	PM2.5D	PM2.5T	BCO2	NBCO2	CO2T	CH4	N2O	R	CO2e					
Onsite	—	—	—	—	—	—	—	—	—	—	—	—	—	—	—	—	—	—	—	—	—	—	—
Daily, Summer (Max)	—	—	—	—	—	—	—	—	—	—	—	—	—	—	—	—	—	—	—	—	—	—	—
Off-Road Equipment	0.33	0.27	1.82	1.74	< 0.005	0.09	—	0.09	0.08	—	0.08	—	269	269	0.01	< 0.005	—	—	—	—	—	—	270
Onsite truck	0.00	0.00	0.00	0.00	0.00	0.00	0.00	0.00	0.00	0.00	0.00	—	0.00	0.00	0.00	0.00	0.00	0.00	0.00	0.00	0.00	0.00	0.00
Daily, Winter (Max)	—	—	—	—	—	—	—	—	—	—	—	—	—	—	—	—	—	—	—	—	—	—	—
Average Daily	—	—	—	—	—	—	—	—	—	—	—	—	—	—	—	—	—	—	—	—	—	—	—
Off-Road Equipment	0.03	0.02	0.15	0.15	< 0.005	0.01	—	0.01	0.01	—	0.01	—	22.8	22.8	< 0.005	< 0.005	—	—	—	—	—	—	22.9
Onsite truck	0.00	0.00	0.00	0.00	0.00	0.00	0.00	0.00	0.00	0.00	0.00	—	0.00	0.00	0.00	0.00	0.00	0.00	0.00	0.00	0.00	0.00	0.00

Mobile source emissions results are presented in Sections 2.6. No further detailed breakdown of emissions is available.

4.2. Energy

4.2.1. Electricity Emissions By Land Use - Unmitigated

Criteria Pollutants (lb/day for daily, ton/yr for annual) and GHGs (lb/day for daily, MT/yr for annual)	Land Use	TOG	ROG	NOx	CO	SO2	PM10E	PM10D	PM10T	PM2.5E	PM2.5D	PM2.5T	BCO2	NBCO2	CO2T	CH4	N2O	R	CO2e	
Daily, Summer (Max)	—	—	—	—	—	—	—	—	—	—	—	—	—	—	—	—	—	—	—	—
Apartments Mid Rise	—	—	—	—	—	—	—	—	—	—	—	—	—	950	950	950	0.07	0.01	—	955
High Turnover (Sit Down Restaurant)	—	—	—	—	—	—	—	—	—	—	—	—	—	431	431	431	0.03	< 0.005	—	433
Enclosed Parking with Elevator	—	—	—	—	—	—	—	—	—	—	—	—	—	260	260	260	0.02	< 0.005	—	261
Total	—	—	—	—	—	—	—	—	—	—	—	—	—	1,641	1,641	1,641	0.12	0.02	—	1,649
Daily, Winter (Max)	—	—	—	—	—	—	—	—	—	—	—	—	—	—	—	—	—	—	—	—
Apartments Mid Rise	—	—	—	—	—	—	—	—	—	—	—	—	—	950	950	950	0.07	0.01	—	955
High Turnover (Sit Down Restaurant)	—	—	—	—	—	—	—	—	—	—	—	—	—	431	431	431	0.03	< 0.005	—	433

Enclosed Parking with Elevator	—	—	—	—	—	—	—	—	—	—	—	—	—	—	—	—	—	—	—	—	260	260	0.02	< 0.005	—	261	
Total	—	—	—	—	—	—	—	—	—	—	—	—	—	—	—	—	—	—	—	—	1,641	1,641	0.12	0.02	—	1,649	
Annual	—	—	—	—	—	—	—	—	—	—	—	—	—	—	—	—	—	—	—	—	—	—	—	—	—	—	
Apartments Mid Rise	—	—	—	—	—	—	—	—	—	—	—	—	—	—	—	—	—	—	—	—	—	157	157	0.01	< 0.005	—	158
High Turnover (Sit Down Restaurant)	—	—	—	—	—	—	—	—	—	—	—	—	—	—	—	—	—	—	—	—	—	71.4	71.4	0.01	< 0.005	—	71.7
Enclosed Parking with Elevator	—	—	—	—	—	—	—	—	—	—	—	—	—	—	—	—	—	—	—	—	—	43.0	43.0	< 0.005	< 0.005	—	43.2
Total	—	—	—	—	—	—	—	—	—	—	—	—	—	—	—	—	—	—	—	—	—	272	272	0.02	< 0.005	—	273

4.2.3. Natural Gas Emissions By Land Use - Unmitigated

Criteria Pollutants (lb/day for daily, ton/yr for annual) and GHGs (lb/day for daily, MT/yr for annual)

Land Use	TOG	ROG	NOX	CO	SO2	PM10E	PM10D	PM10T	PM2.5E	PM2.5D	PM2.5T	BCO2	NBCO2	CO2T	CH4	N2O	R	CO2e	
Daily, Summer (Max)	—	—	—	—	—	—	—	—	—	—	—	—	—	—	—	—	—	—	—
Apartments Mid Rise	0.04	0.02	0.38	0.16	< 0.005	0.03	—	0.03	0.03	—	0.03	—	487	487	0.04	< 0.005	—	488	
High Turnover (Sit Down Restaurant)	0.02	0.01	0.18	0.15	< 0.005	0.01	—	0.01	0.01	—	0.01	—	213	213	0.02	< 0.005	—	213	

4.3.2. Unmitigated

Criteria Pollutants (lb/day for daily, ton/yr for annual) and GHGs (lb/day for daily, MT/yr for annual)

Source	TOG	ROG	NOx	CO	SO2	PM10E	PM10D	PM10T	PM2.5E	PM2.5D	PM2.5T	BCO2	NBCO2	CO2T	CH4	N2O	R	CO2e
Daily, Summer (Max)	—	—	—	—	—	—	—	—	—	—	—	—	—	—	—	—	—	—
Hearths	0.00	0.00	0.00	0.00	0.00	0.00	—	0.00	—	—	0.00	0.00	0.00	0.00	0.00	0.00	—	0.00
Consumer Products	—	3.07	—	—	—	—	—	—	—	—	—	—	—	—	—	—	—	—
Architectural Coatings	—	0.25	—	—	—	—	—	—	—	—	—	—	—	—	—	—	—	—
Landscaping Equipment	1.15	1.08	0.10	10.6	< 0.005	0.01	—	0.01	—	—	0.01	—	31.1	31.1	< 0.005	< 0.005	—	31.2
Total	1.15	4.40	0.10	10.6	< 0.005	0.01	—	0.01	—	—	0.01	0.00	31.1	31.1	< 0.005	< 0.005	—	31.2
Daily, Winter (Max)	—	—	—	—	—	—	—	—	—	—	—	—	—	—	—	—	—	—
Hearths	0.00	0.00	0.00	0.00	0.00	0.00	—	0.00	—	—	0.00	0.00	0.00	0.00	0.00	0.00	—	0.00
Consumer Products	—	3.07	—	—	—	—	—	—	—	—	—	—	—	—	—	—	—	—
Architectural Coatings	—	0.25	—	—	—	—	—	—	—	—	—	—	—	—	—	—	—	—
Total	0.00	3.32	0.00	0.00	0.00	0.00	—	0.00	—	—	0.00	0.00	0.00	0.00	0.00	0.00	—	0.00
Annual	—	—	—	—	—	—	—	—	—	—	—	—	—	—	—	—	—	—
Hearths	0.00	0.00	0.00	0.00	0.00	0.00	—	0.00	—	—	0.00	0.00	0.00	0.00	0.00	0.00	—	0.00

Consumer Products	—	0.56	—	—	—	—	—	—	—	—	—	—	—	—	—	—	—	—	—	—	—	
Architectural Coatings	—	0.05	—	—	—	—	—	—	—	—	—	—	—	—	—	—	—	—	—	—	—	
Landscape Equipment	0.14	0.13	0.01	1.33	< 0.005	< 0.005	—	< 0.005	< 0.005	< 0.005	—	< 0.005	< 0.005	—	< 0.005	—	3.53	3.53	< 0.005	< 0.005	—	3.54
Total	0.14	0.74	0.01	1.33	< 0.005	< 0.005	—	< 0.005	< 0.005	< 0.005	—	< 0.005	< 0.005	0.00	3.53	3.53	< 0.005	< 0.005	—	< 0.005	—	3.54

4.4. Water Emissions by Land Use

4.4.2. Unmitigated

Criteria Pollutants (lb/day for daily, ton/yr for annual) and GHGs (lb/day for daily, MT/yr for annual)

Land Use	TOG	ROG	NOx	CO	SO2	PM10E	PM10D	PM10T	PM2.5E	PM2.5D	PM2.5T	BCO2	NBCO2	CO2T	CH4	N2O	R	CO2e	
Daily, Summer (Max)	—	—	—	—	—	—	—	—	—	—	—	—	—	—	—	—	—	—	—
Apartments Mid Rise	—	—	—	—	—	—	—	—	—	—	—	10.9	73.9	84.8	1.13	0.03	—	121	
High Turnover (Sit Down Restaurant)	—	—	—	—	—	—	—	—	—	—	—	4.07	27.4	31.4	0.42	0.01	—	45.0	
Enclosed Parking with Elevator	—	—	—	—	—	—	—	—	—	—	—	0.00	0.00	0.00	0.00	0.00	—	0.00	
Total	—	—	—	—	—	—	—	—	—	—	—	15.0	101	116	1.55	0.04	—	166	

High Turnover (Sit Down Restaurant)	-	-	-	-	-	-	-	-	-	-	-	-	-	-	-	7.43	0.00	7.43	0.74	0.00	-	26.0
Enclosed Parking with Elevator	-	-	-	-	-	-	-	-	-	-	-	-	-	-	-	0.00	0.00	0.00	0.00	0.00	-	0.00
Total	-	-	-	-	-	-	-	-	-	-	-	-	-	-	-	15.5	0.00	15.5	1.55	0.00	-	54.2

4.6. Refrigerant Emissions by Land Use

4.6.1. Unmitigated

Criteria Pollutants (lb/day for daily, ton/yr for annual) and GHGs (lb/day for daily, MT/yr for annual)

Land Use	TOG	ROG	NOx	CO	SO2	PM10E	PM10D	PM10T	PM2.5E	PM2.5D	PM2.5T	BCO2	NBCO2	CO2T	CH4	N2O	R	CO2e	
Daily, Summer (Max)	-	-	-	-	-	-	-	-	-	-	-	-	-	-	-	-	-	-	-
Apartments Mid Rise	-	-	-	-	-	-	-	-	-	-	-	-	-	-	-	-	-	0.98	0.98
High Turnover (Sit Down Restaurant)	-	-	-	-	-	-	-	-	-	-	-	-	-	-	-	-	-	10.9	10.9
Total	-	-	-	-	-	-	-	-	-	-	-	-	-	-	-	-	-	11.9	11.9
Daily, Winter (Max)	-	-	-	-	-	-	-	-	-	-	-	-	-	-	-	-	-	-	-
Apartments Mid Rise	-	-	-	-	-	-	-	-	-	-	-	-	-	-	-	-	-	0.98	0.98

High Turnover (Sit Down Restaurants)	–	–	–	–	–	–	–	–	–	–	–	–	–	–	–	–	–	–	10.9	10.9
Total	–	–	–	–	–	–	–	–	–	–	–	–	–	–	–	–	–	–	11.9	11.9
Annual	–	–	–	–	–	–	–	–	–	–	–	–	–	–	–	–	–	–	–	–
Apartments	–	–	–	–	–	–	–	–	–	–	–	–	–	–	–	–	–	–	0.16	0.16
Mid Rise	–	–	–	–	–	–	–	–	–	–	–	–	–	–	–	–	–	–	–	–
High Turnover (Sit Down Restaurants)	–	–	–	–	–	–	–	–	–	–	–	–	–	–	–	–	–	–	1.81	1.81
Total	–	–	–	–	–	–	–	–	–	–	–	–	–	–	–	–	–	–	1.97	1.97

4.7. Offroad Emissions By Equipment Type

4.7.1. Unmitigated

Criteria Pollutants (lb/day for daily, ton/yr for annual) and GHGs (lb/day for daily, MT/yr for annual)

Equipment Type	TOG	ROG	NOx	CO	SO2	PM10E	PM10D	PM10T	PM2.5E	PM2.5D	PM2.5T	BCO2	NBCO2	CO2T	CH4	N2O	R	CO2e	
Daily, Summer (Max)	–	–	–	–	–	–	–	–	–	–	–	–	–	–	–	–	–	–	–
Total	–	–	–	–	–	–	–	–	–	–	–	–	–	–	–	–	–	–	–
Daily, Winter (Max)	–	–	–	–	–	–	–	–	–	–	–	–	–	–	–	–	–	–	–
Total	–	–	–	–	–	–	–	–	–	–	–	–	–	–	–	–	–	–	–
Annual	–	–	–	–	–	–	–	–	–	–	–	–	–	–	–	–	–	–	–
Total	–	–	–	–	–	–	–	–	–	–	–	–	–	–	–	–	–	–	–

4.8. Stationary Emissions By Equipment Type

4.8.1. Unmitigated

Criteria Pollutants (lb/day for daily, ton/yr for annual) and GHGs (lb/day for daily, MT/yr for annual)

Equipment Type	TOG	ROG	NOx	CO	SO2	PM10E	PM10D	PM10T	PM2.5E	PM2.5D	PM2.5T	BCO2	NBCO2	CO2T	CH4	N2O	R	CO2e
Daily, Summer (Max)	-	-	-	-	-	-	-	-	-	-	-	-	-	-	-	-	-	-
Total	-	-	-	-	-	-	-	-	-	-	-	-	-	-	-	-	-	-
Daily, Winter (Max)	-	-	-	-	-	-	-	-	-	-	-	-	-	-	-	-	-	-
Total	-	-	-	-	-	-	-	-	-	-	-	-	-	-	-	-	-	-
Annual	-	-	-	-	-	-	-	-	-	-	-	-	-	-	-	-	-	-
Total	-	-	-	-	-	-	-	-	-	-	-	-	-	-	-	-	-	-

4.9. User Defined Emissions By Equipment Type

4.9.1. Unmitigated

Criteria Pollutants (lb/day for daily, ton/yr for annual) and GHGs (lb/day for daily, MT/yr for annual)

Equipment Type	TOG	ROG	NOx	CO	SO2	PM10E	PM10D	PM10T	PM2.5E	PM2.5D	PM2.5T	BCO2	NBCO2	CO2T	CH4	N2O	R	CO2e
Daily, Summer (Max)	-	-	-	-	-	-	-	-	-	-	-	-	-	-	-	-	-	-
Total	-	-	-	-	-	-	-	-	-	-	-	-	-	-	-	-	-	-
Daily, Winter (Max)	-	-	-	-	-	-	-	-	-	-	-	-	-	-	-	-	-	-

Total	-	-	-	-	-	-	-	-	-	-	-	-	-	-	-	-	-	-	-	-	-	-	-	-
Annual	-	-	-	-	-	-	-	-	-	-	-	-	-	-	-	-	-	-	-	-	-	-	-	-
Total	-	-	-	-	-	-	-	-	-	-	-	-	-	-	-	-	-	-	-	-	-	-	-	-

4.10. Soil Carbon Accumulation By Vegetation Type

4.10.1. Soil Carbon Accumulation By Vegetation Type - Unmitigated

Criteria Pollutants (lb/day for daily, ton/yr for annual) and GHGs (lb/day for daily, MT/yr for annual)

Vegetation	TOG	ROG	NOx	CO	SO2	PM10E	PM10D	PM10T	PM2.5E	PM2.5D	PM2.5T	BCO2	NBCO2	CO2T	CH4	N2O	R	CO2e	
Daily, Summer (Max)	-	-	-	-	-	-	-	-	-	-	-	-	-	-	-	-	-	-	-
Total	-	-	-	-	-	-	-	-	-	-	-	-	-	-	-	-	-	-	-
Daily, Winter (Max)	-	-	-	-	-	-	-	-	-	-	-	-	-	-	-	-	-	-	-
Total	-	-	-	-	-	-	-	-	-	-	-	-	-	-	-	-	-	-	-
Annual	-	-	-	-	-	-	-	-	-	-	-	-	-	-	-	-	-	-	-
Total	-	-	-	-	-	-	-	-	-	-	-	-	-	-	-	-	-	-	-

4.10.2. Above and Belowground Carbon Accumulation by Land Use Type - Unmitigated

Criteria Pollutants (lb/day for daily, ton/yr for annual) and GHGs (lb/day for daily, MT/yr for annual)

Land Use	TOG	ROG	NOx	CO	SO2	PM10E	PM10D	PM10T	PM2.5E	PM2.5D	PM2.5T	BCO2	NBCO2	CO2T	CH4	N2O	R	CO2e	
Daily, Summer (Max)	-	-	-	-	-	-	-	-	-	-	-	-	-	-	-	-	-	-	-
Total	-	-	-	-	-	-	-	-	-	-	-	-	-	-	-	-	-	-	-

Daily, Winter (Max)	-	-	-	-	-	-	-	-	-	-	-	-	-	-	-	-	-	-	-	-	-	-	-	-	-	-
Total	-	-	-	-	-	-	-	-	-	-	-	-	-	-	-	-	-	-	-	-	-	-	-	-	-	-
Annual	-	-	-	-	-	-	-	-	-	-	-	-	-	-	-	-	-	-	-	-	-	-	-	-	-	-
Total	-	-	-	-	-	-	-	-	-	-	-	-	-	-	-	-	-	-	-	-	-	-	-	-	-	-

4.10.3. Avoided and Sequestered Emissions by Species - Unmitigated

Criteria Pollutants (lb/day for daily, ton/yr for annual) and GHGs (lb/day for daily, MT/yr for annual)

Species	TOG	ROG	NOx	CO	SO2	PM10E	PM10D	PM10T	PM2.5E	PM2.5D	PM2.5T	BCO2	NBCO2	CO2T	CH4	N2O	R	CO2e	
Daily, Summer (Max)	-	-	-	-	-	-	-	-	-	-	-	-	-	-	-	-	-	-	-
Avoided	-	-	-	-	-	-	-	-	-	-	-	-	-	-	-	-	-	-	-
Subtotal	-	-	-	-	-	-	-	-	-	-	-	-	-	-	-	-	-	-	-
Sequestered	-	-	-	-	-	-	-	-	-	-	-	-	-	-	-	-	-	-	-
Subtotal	-	-	-	-	-	-	-	-	-	-	-	-	-	-	-	-	-	-	-
Removed	-	-	-	-	-	-	-	-	-	-	-	-	-	-	-	-	-	-	-
Subtotal	-	-	-	-	-	-	-	-	-	-	-	-	-	-	-	-	-	-	-
Daily, Winter (Max)	-	-	-	-	-	-	-	-	-	-	-	-	-	-	-	-	-	-	-
Avoided	-	-	-	-	-	-	-	-	-	-	-	-	-	-	-	-	-	-	-
Subtotal	-	-	-	-	-	-	-	-	-	-	-	-	-	-	-	-	-	-	-
Sequestered	-	-	-	-	-	-	-	-	-	-	-	-	-	-	-	-	-	-	-
Subtotal	-	-	-	-	-	-	-	-	-	-	-	-	-	-	-	-	-	-	-

Removed	—	—	—	—	—	—	—	—	—	—	—	—	—	—	—	—	—	—	—	—
Subtotal	—	—	—	—	—	—	—	—	—	—	—	—	—	—	—	—	—	—	—	—
—	—	—	—	—	—	—	—	—	—	—	—	—	—	—	—	—	—	—	—	—
Annual	—	—	—	—	—	—	—	—	—	—	—	—	—	—	—	—	—	—	—	—
Avoided	—	—	—	—	—	—	—	—	—	—	—	—	—	—	—	—	—	—	—	—
Subtotal	—	—	—	—	—	—	—	—	—	—	—	—	—	—	—	—	—	—	—	—
Sequestered	—	—	—	—	—	—	—	—	—	—	—	—	—	—	—	—	—	—	—	—
Subtotal	—	—	—	—	—	—	—	—	—	—	—	—	—	—	—	—	—	—	—	—
Removed	—	—	—	—	—	—	—	—	—	—	—	—	—	—	—	—	—	—	—	—
Subtotal	—	—	—	—	—	—	—	—	—	—	—	—	—	—	—	—	—	—	—	—
—	—	—	—	—	—	—	—	—	—	—	—	—	—	—	—	—	—	—	—	—

5. Activity Data

5.1. Construction Schedule

Phase Name	Phase Type	Start Date	End Date	Days Per Week	Work Days per Phase	Phase Description
Demolition	Demolition	1/2/2024	3/31/2024	5.00	64.0	—
Grading	Grading	4/1/2024	5/31/2024	5.00	45.0	—
Building Construction	Building Construction	6/1/2024	7/31/2026	5.00	565	—
Architectural Coating	Architectural Coating	3/2/2026	11/30/2026	5.00	196	—
Trenching	Trenching	6/1/2024	7/15/2024	5.00	31.0	—

5.2. Off-Road Equipment

5.2.1. Unmitigated

Phase Name	Equipment Type	Fuel Type	Engine Tier	Number per Day	Hours Per Day	Horsepower	Load Factor
Demolition	Concrete/Industrial Saws	Diesel	Average	1.00	8.00	33.0	0.73
Demolition	Rubber Tired Dozers	Diesel	Average	1.00	1.00	367	0.40
Demolition	Tractors/Loaders/Backhoes	Diesel	Average	2.00	6.00	84.0	0.37
Grading	Graders	Diesel	Average	1.00	6.00	148	0.41
Grading	Rubber Tired Dozers	Diesel	Average	1.00	6.00	367	0.40
Grading	Tractors/Loaders/Backhoes	Diesel	Average	1.00	7.00	84.0	0.37
Building Construction	Cranes	Diesel	Average	1.00	4.00	367	0.29
Building Construction	Forklifts	Diesel	Average	2.00	6.00	82.0	0.20
Building Construction	Tractors/Loaders/Backhoes	Diesel	Average	2.00	8.00	84.0	0.37
Architectural Coating	Air Compressors	Diesel	Average	1.00	6.00	37.0	0.48
Trenching	Dumpers/Tenders	Diesel	Average	1.00	8.00	16.0	0.38
Trenching	Trenchers	Diesel	Average	1.00	8.00	40.0	0.50

5.3. Construction Vehicles

5.3.1. Unmitigated

Phase Name	Trip Type	One-Way Trips per Day	Miles per Trip	Vehicle Mix
Demolition	—	—	—	—
Demolition	Worker	10.0	18.5	LDA,LDT1 ,LDT2
Demolition	Vendor	—	10.2	HHD1,MHDT
Demolition	Hauling	13.3	30.0	HHD1
Demolition	Onsite truck	—	—	HHD1
Grading	—	—	—	—
Grading	Worker	7.50	18.5	LDA,LDT1 ,LDT2

Grading	Vendor	—	10.2	HHDT,MHDT
Grading	Hauling	44.4	30.0	HHDT
Grading	Onsite truck	—	—	HHDT
Building Construction	—	—	—	—
Building Construction	Worker	129	18.5	LDA,LDT1 ,LDT2
Building Construction	Vendor	23.6	10.2	HHDT,MHDT
Building Construction	Hauling	0.00	20.0	HHDT
Building Construction	Onsite truck	—	—	HHDT
Architectural Coating	—	—	—	—
Architectural Coating	Worker	25.7	18.5	LDA,LDT1 ,LDT2
Architectural Coating	Vendor	—	10.2	HHDT,MHDT
Architectural Coating	Hauling	0.00	20.0	HHDT
Architectural Coating	Onsite truck	—	—	HHDT
Trenching	—	—	—	—
Trenching	Worker	5.00	18.5	LDA,LDT1 ,LDT2
Trenching	Vendor	—	10.2	HHDT,MHDT
Trenching	Hauling	0.00	20.0	HHDT
Trenching	Onsite truck	—	—	HHDT

5.4. Vehicles

5.4.1. Construction Vehicle Control Strategies

Non-applicable. No control strategies activated by user.

5.5. Architectural Coatings

Phase Name	Residential Interior Area Coated (sq ft)	Residential Exterior Area Coated (sq ft)	Non-Residential Interior Area Coated (sq ft)	Non-Residential Exterior Area Coated (sq ft)	Parking Area Coated (sq ft)
Architectural Coating	275,997	91,999	10,500	3,500	—

5.6. Dust Mitigation

5.6.1. Construction Earthmoving Activities

Phase Name	Material Imported (Cubic Yards)	Material Exported (Cubic Yards)	Acres Graded (acres)	Material Demolished (Ton of Debris)	Acres Paved (acres)
Demolition	0.00	0.00	0.00	2,336	—
Grading	—	10,000	0.94	0.00	—

5.6.2. Construction Earthmoving Control Strategies

Control Strategies Applied	Frequency (per day)	PM10 Reduction	PM2.5 Reduction
Water Exposed Area	2	61%	61%
Water Demolished Area	2	36%	36%

5.7. Construction Paving

Land Use	Area Paved (acres)	% Asphalt
Apartments Mid Rise	—	0%
High Turnover (Sit Down Restaurant)	0.00	0%
Enclosed Parking with Elevator	0.00	100%

5.8. Construction Electricity Consumption and Emissions Factors

kWh per Year and Emission Factor (lb/MWh)

Year	kWh per Year	CO2	CH4	N2O
2024	0.00	690	0.05	0.01
2025	0.00	690	0.05	0.01
2026	0.00	690	0.05	0.01

5.9. Operational Mobile Sources

5.9.1. Unmitigated

Land Use Type	Trips/Weekday	Trips/Saturday	Trips/Sunday	Trips/Year	VMT/Weekday	VMT/Saturday	VMT/Sunday	VMT/Year
Total all Land Uses	892	892	892	325,580	5,297	5,297	5,297	1,933,405

5.10. Operational Area Sources

5.10.1. Hearths

5.10.1.1. Unmitigated

Hearth Type	Unmitigated (number)
Apartments Mid Rise	—
Wood Fireplaces	0
Gas Fireplaces	0
Propane Fireplaces	0
Electric Fireplaces	0
No Fireplaces	153
Conventional Wood Stoves	0
Catalytic Wood Stoves	0
Non-Catalytic Wood Stoves	0
Pellet Wood Stoves	0

5.10.2. Architectural Coatings

Residential Interior Area Coated (sq ft)	Residential Exterior Area Coated (sq ft)	Non-Residential Interior Area Coated (sq ft)	Non-Residential Exterior Area Coated (sq ft)	Parking Area Coated (sq ft)
275997.375	91,999	10,500	3,500	—

5.10.3. Landscape Equipment

Season	Unit	Value
Snow Days	day/yr	0.00
Summer Days	day/yr	250

5.11. Operational Energy Consumption

5.11.1. Unmitigated

Electricity (kWh/yr) and CO2 and CH4 and N2O and Natural Gas (KBTU/yr)

Land Use	Electricity (kWh/yr)	CO2	CH4	N2O	Natural Gas (KBTU/yr)
Apartments Mid Rise	502,375	690	0.0489	0.0069	1,518,580
High Turnover (Sit Down Restaurant)	227,991	690	0.0489	0.0069	663,107
Enclosed Parking with Elevator	137,321	690	0.0489	0.0069	0.00

5.12. Operational Water and Wastewater Consumption

5.12.1. Unmitigated

Land Use	Indoor Water (gal/year)	Outdoor Water (gal/year)
Apartments Mid Rise	5,702,891	42,099
High Turnover (Sit Down Restaurant)	2,124,736	0.00
Enclosed Parking with Elevator	0.00	0.00

5.13. Operational Waste Generation

5.13.1. Unmitigated

Land Use	Waste (ton/year)	Cogeneration (kWh/year)
Land Use	Waste (ton/year)	Cogeneration (kWh/year)

Apartments Mid Rise		38.2		0.00
High Turnover (Sit Down Restaurant)		83.3		0.00
Enclosed Parking with Elevator		0.00		0.00

5.14. Operational Refrigeration and Air Conditioning Equipment

5.14.1. Unmitigated

Land Use Type	Equipment Type	Refrigerant	GWP	Quantity (kg)	Operations Leak Rate	Service Leak Rate	Times Serviced
Apartments Mid Rise	Average room A/C & Other residential A/C and heat pumps	R-410A	2,088	< 0.005	2.50	2.50	10.0
Apartments Mid Rise	Household refrigerators and/or freezers	R-134a	1,430	0.12	0.60	0.00	1.00
High Turnover (Sit Down Restaurant)	Household refrigerators and/or freezers	R-134a	1,430	0.00	0.60	0.00	1.00
High Turnover (Sit Down Restaurant)	Other commercial A/C and heat pumps	R-410A	2,088	1.80	4.00	4.00	18.0
High Turnover (Sit Down Restaurant)	Walk-in refrigerators and freezers	R-404A	3,922	< 0.005	7.50	7.50	20.0

5.15. Operational Off-Road Equipment

5.15.1. Unmitigated

Equipment Type	Fuel Type	Engine Tier	Number per Day	Hours Per Day	Horsepower	Load Factor
----------------	-----------	-------------	----------------	---------------	------------	-------------

5.16. Stationary Sources

5.16.1. Emergency Generators and Fire Pumps

Equipment Type	Fuel Type	Number per Day	Hours per Day	Hours per Year	Horsepower	Load Factor
----------------	-----------	----------------	---------------	----------------	------------	-------------

5.16.2. Process Boilers

Equipment Type	Fuel Type	Number	Boiler Rating (MMBtu/hr)	Daily Heat Input (MMBtu/day)	Annual Heat Input (MMBtu/yr)
----------------	-----------	--------	--------------------------	------------------------------	------------------------------

5.17. User Defined

Equipment Type	Fuel Type
-	-

5.18. Vegetation

5.18.1. Land Use Change

5.18.1.1. Unmitigated

Vegetation Land Use Type	Vegetation Soil Type	Initial Acres	Final Acres
--------------------------	----------------------	---------------	-------------

5.18.1. Biomass Cover Type

5.18.1.1. Unmitigated

Biomass Cover Type	Initial Acres	Final Acres
--------------------	---------------	-------------

5.18.2. Sequestration

5.18.2.1. Unmitigated

Tree Type	Number	Electricity Saved (kWh/year)	Natural Gas Saved (btu/year)
-----------	--------	------------------------------	------------------------------

6. Climate Risk Detailed Report

6.1. Climate Risk Summary

Cal-Adapt midcentury 2040–2059 average projections for four hazards are reported below for your project location. These are under Representation Concentration Pathway (RCP) 8.5 which assumes GHG emissions will continue to rise strongly through 2050 and then plateau around 2100.

Climate Hazard	Result for Project Location	Unit
Temperature and Extreme Heat	7.38	annual days of extreme heat
Extreme Precipitation	6.85	annual days with precipitation above 20 mm
Sea Level Rise	0.00	meters of inundation depth
Wildfire	0.00	annual hectares burned

Temperature and Extreme Heat data are for grid cell in which your project are located. The projection is based on the 98th historical percentile of daily maximum/minimum temperatures from observed historical data (32 climate model ensemble from Cal-Adapt, 2040–2059 average under RCP 8.5). Each grid cell is 6 kilometers (km) by 6 km, or 3.7 miles (mi) by 3.7 mi.

Extreme Precipitation data are for the grid cell in which your project are located. The threshold of 20 mm is equivalent to about $\frac{3}{4}$ an inch of rain, which would be light to moderate rainfall if received over a full day or heavy rain if received over a period of 2 to 4 hours. Each grid cell is 6 kilometers (km) by 6 km, or 3.7 miles (mi) by 3.7 mi.

Sea Level Rise data are for the grid cell in which your project are located. The projections are from Radke et al. (2017), as reported in Cal-Adapt (2040–2059 average under RCP 8.5), and consider different increments of sea level rise coupled with extreme storm events. Users may select from four model simulations to view the range in potential inundation depth for the grid cell. The four simulations make different assumptions about expected rainfall and temperature are: Warmer/drier (HadGEM2-ES), Cooler/wetter (CNRM-CM5), Average conditions (CanESM2), Range of different rainfall and temperature possibilities (MIROC5). Each grid cell is 50 meters (m) by 50 m, or about 164 feet (ft) by 164 ft.

Wildfire data are for the grid cell in which your project are located. The projections are from UC Davis, as reported in Cal-Adapt (2040–2059 average under RCP 8.5), and consider historical data of climate, vegetation, population density, and large (> 400 ha) fire history. Users may select from four model simulations to view the range in potential wildfire probabilities for the grid cell. The four simulations make different assumptions about expected rainfall and temperature are: Warmer/drier (HadGEM2-ES), Cooler/wetter (CNRM-CM5), Average conditions (CanESM2), Range of different rainfall and temperature possibilities (MIROC5). Each grid cell is 6 kilometers (km) by 6 km, or 3.7 miles (mi) by 3.7 mi.

6.2. Initial Climate Risk Scores

Climate Hazard	Exposure Score	Sensitivity Score	Adaptive Capacity Score	Vulnerability Score
Temperature and Extreme Heat	1	0	0	N/A
Extreme Precipitation	N/A	N/A	N/A	N/A
Sea Level Rise	1	0	0	N/A
Wildfire	1	0	0	N/A
Flooding	N/A	N/A	N/A	N/A
Drought	N/A	N/A	N/A	N/A
Snowpack	N/A	N/A	N/A	N/A
Air Quality	0	0	0	N/A

The sensitivity score reflects the extent to which a project would be adversely affected by exposure to a climate hazard. Exposure is rated on a scale of 1 to 5, with a score of 5 representing the greatest exposure.

The adaptive capacity of a project refers to its ability to manage and reduce vulnerabilities from projected climate hazards. Adaptive capacity is rated on a scale of 1 to 5, with a score of 5 representing the greatest ability to adapt.

The overall vulnerability scores are calculated based on the potential impacts and adaptive capacity assessments for each hazard. Scores do not include implementation of climate risk reduction measures.

6.3. Adjusted Climate Risk Scores

Climate Hazard	Exposure Score	Sensitivity Score	Adaptive Capacity Score	Vulnerability Score
Temperature and Extreme Heat	1	1	1	2
Extreme Precipitation	N/A	N/A	N/A	N/A
Sea Level Rise	1	1	1	2
Wildfire	1	1	1	2
Flooding	N/A	N/A	N/A	N/A
Drought	N/A	N/A	N/A	N/A
Snowpack	N/A	N/A	N/A	N/A
Air Quality	1	1	1	2

The sensitivity score reflects the extent to which a project would be adversely affected by exposure to a climate hazard. Exposure is rated on a scale of 1 to 5, with a score of 5 representing the greatest exposure.

The adaptive capacity of a project refers to its ability to manage and reduce vulnerabilities from projected climate hazards. Adaptive capacity is rated on a scale of 1 to 5, with a score of 5 representing the greatest ability to adapt.

The overall vulnerability scores are calculated based on the potential impacts and adaptive capacity assessments for each hazard. Scores include implementation of climate risk reduction measures.

6.4. Climate Risk Reduction Measures

7. Health and Equity Details

7.1. CalEnviroScreen 4.0 Scores

The maximum CalEnviroScreen score is 100. A high score (i.e., greater than 50) reflects a higher pollution burden compared to other census tracts in the state.

Indicator	Result for Project Census Tract
Exposure Indicators	—
AQ-Ozone	59.7

AQ-PM	77.2
AQ-DPM	98.1
Drinking Water	92.5
Lead Risk Housing	68.0
Pesticides	0.00
Toxic Releases	72.2
Traffic	66.2
Effect Indicators	—
CleanUp Sites	77.0
Groundwater	73.5
Haz Waste Facilities/Generators	73.8
Impaired Water Bodies	0.00
Solid Waste	12.9
Sensitive Population	—
Asthma	60.2
Cardio-vascular	54.9
Low Birth Weights	93.7
Socioeconomic Factor Indicators	—
Education	55.8
Housing	67.7
Linguistic	96.0
Poverty	95.1
Unemployment	98.4

7.2. Healthy Places Index Scores

The maximum Health Places Index score is 100. A high score (i.e., greater than 50) reflects healthier community conditions compared to other census tracts in the state.

Indicator	Result for Project Census Tract
-----------	---------------------------------

Economic	—
Above Poverty	7.160272039
Employed	33.54292314
Median HI	0.61593738
Education	—
Bachelor's or higher	59.70742974
High school enrollment	100
Preschool enrollment	95.7141024
Transportation	—
Auto Access	0.949570127
Active commuting	95.70127037
Social	—
2-parent households	5.594764532
Voting	22.44321827
Neighborhood	—
Alcohol availability	4.516874118
Park access	81.35506224
Retail density	98.37033235
Supermarket access	94.25125112
Tree canopy	25.47157706
Housing	—
Homeownership	3.015526755
Housing habitability	16.14269216
Low-inc homeowner severe housing cost burden	14.65417683
Low-inc renter severe housing cost burden	54.95957911
Uncrowded housing	24.00872578
Health Outcomes	—

Insured adults	31.56679071
Arthritis	18.8
Asthma ER Admissions	42.0
High Blood Pressure	13.8
Cancer (excluding skin)	32.7
Asthma	32.2
Coronary Heart Disease	4.7
Chronic Obstructive Pulmonary Disease	9.6
Diagnosed Diabetes	15.4
Life Expectancy at Birth	83.7
Cognitively Disabled	41.3
Physically Disabled	21.0
Heart Attack ER Admissions	47.6
Mental Health Not Good	27.8
Chronic Kidney Disease	10.6
Obesity	27.3
Pedestrian Injuries	65.9
Physical Health Not Good	17.0
Stroke	7.6
Health Risk Behaviors	—
Binge Drinking	75.2
Current Smoker	28.0
No Leisure Time for Physical Activity	27.1
Climate Change Exposures	—
Wildfire Risk	0.0
SLR Inundation Area	0.0
Children	88.7

Elderly	8.1
English Speaking	1.3
Foreign-born	95.9
Outdoor Workers	54.7
Climate Change Adaptive Capacity	—
Impervious Surface Cover	5.6
Traffic Density	86.9
Traffic Access	87.4
Other Indices	—
Hardship	79.2
Other Decision Support	—
2016 Voting	11.9

7.3. Overall Health & Equity Scores

Metric	Result for Project Census Tract
CalEnviroScreen 4.0 Score for Project Location (a)	95.0
Healthy Places Index Score for Project Location (b)	18.0
Project Located in a Designated Disadvantaged Community (Senate Bill 535)	Yes
Project Located in a Low-Income Community (Assembly Bill 1550)	Yes
Project Located in a Community Air Protection Program Community (Assembly Bill 617)	No

a: The maximum CalEnviroScreen score is 100. A high score (i.e., greater than 50) reflects a higher pollution burden compared to other census tracts in the state.

b: The maximum Health Places Index score is 100. A high score (i.e., greater than 50) reflects healthier community conditions compared to other census tracts in the state.

7.4. Health & Equity Measures

No Health & Equity Measures selected.

7.5. Evaluation Scorecard

Health & Equity Evaluation Scorecard not completed.

7.6. Health & Equity Custom Measures

No Health & Equity Custom Measures created.

8. User Changes to Default Data

Screen	Justification
Land Use	Project plans. Population estimate from LA VMT Calculator, v1.3
Construction: Construction Phases	Developer information
Construction: Off-Road Equipment	Consultant assumptions for trenching
Construction: Dust From Material Movement	Estimates provided by the Applicant, July 2022. Assumes 8,439 cy with a soil swell percent of 18.5% = 10,000 cy.
Construction: Trips and VMT	10cy haul truck capacity
Operations: Hearths	Project plans



DOUGLASKIM+ASSOCIATES,LLC

MATES V TOXIC EMISSIONS OVERVIEW

About Air Toxics Cancer Risk

Information about community profile statistics
Information about emission sources
Download PDF

Residential Air Toxics Cancer Risk at MATES Monitoring Sites

Residential Air Toxics Cancer Risk Calculated from Model Data

Cancer risk [per million]



South Coast AQMD Boundary

The air toxics cancer risk data presented in the MATES Data Visualization is calculated using a population-weighted average.

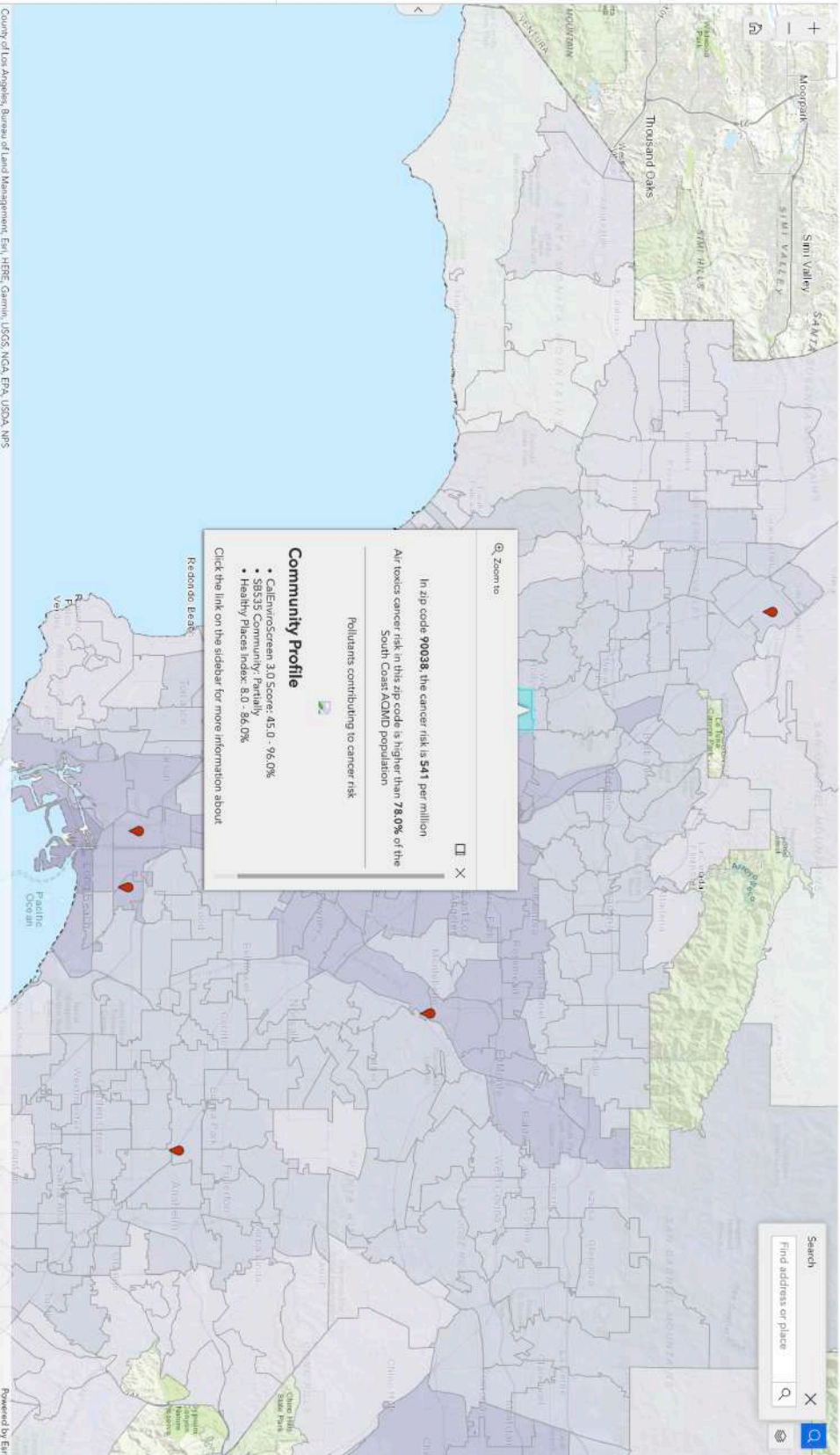



DOUGLASKIM+ASSOCIATES,LLC

CALENVIROSCREEN 4.0 OUTPUT

The CalEnviroScreen 4.0 tool shows cumulative impacts in California communities by census tract.

How to use this map

- Use your mouse or touchpad to pan around.
- Zoom In/out with a mouse wheel or the +/- icons.
- Search by location or census tract number with the search icon.
- Click on a census tract to view additional information in the pop-up window.
- Dock the pop-up window to the side of the screen by clicking the dock icon.
- Export a map view that includes the legend and popup using the screenshot widget.
- Learn more about CalEnviroScreen 4.0 and how this map was created here.

Overall Percentile

CalEnviroScreen 4.0 Results

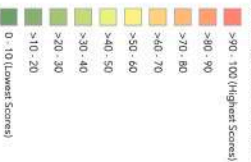

CalEnviroScreen 4.0 High Pollution, Low Population

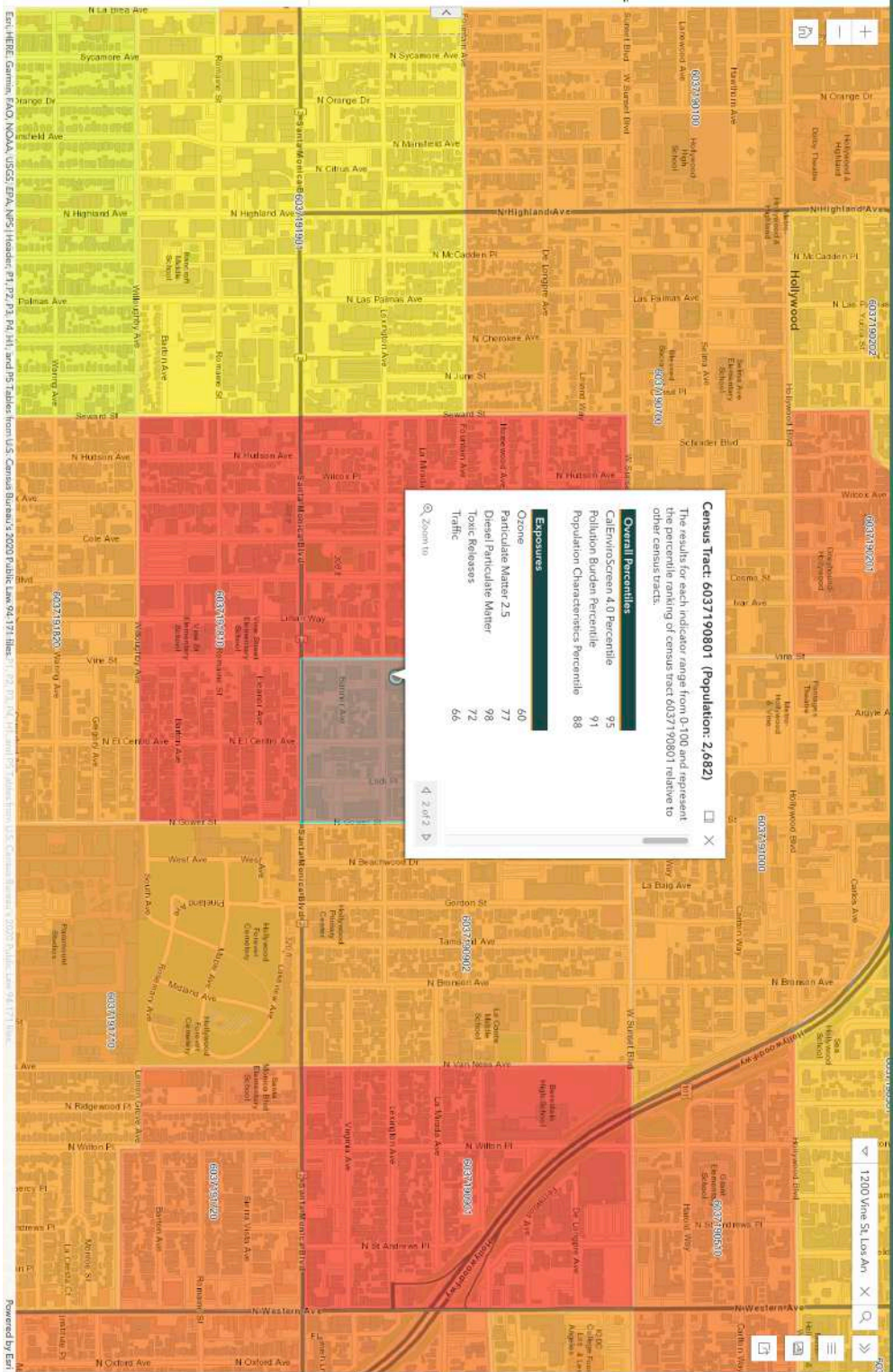



DOUGLASKIM+ASSOCIATES,LLC

DEMOLITION ANALYSIS



Douglas Kim + Associates, LLC

CONSTRUCTION BUILDING DEBRIS

Materials	Total SF	Height	Cubic Yards	Pounds per Cub	Tons	Truck Capacity (CY)	Truck Trips	Source
Construction and Debris	0	0	-	484	-	10	-	Florida Department of Environmental Protection A Fact Sheet for C&D Debris Facility Operators <i>Federal Emergency Management Agency, Debris Estimating Field Guide (FEMA 329), September 2010. General Building Formula</i>
General Building	27,011	12	3,962	1,000	1,981	10	792	<i>Federal Emergency Management Agency, Debris Estimating Field Guide (FEMA 329), September 2010. Single Family Residence Formula, assumes 1 story, Medium vegetative cover multiplier (1.3)</i>
Single Family Residence	-	12	-	1,000	-	10	-	
Multi-Family Residence	-	12	-	1,000	-	10	-	
Mobile Home	-	-	-	1,000	-	10	-	
Mixed Debris	-	-	-	480	-	10	-	Florida Department of Environmental Protection A Fact Sheet for C&D Debris Facility Operators
Vegetative Debris (Hardwoods)	-	-	-	500	-	10	-	
Vegetative Debris (Softwoods)	-	-	-	333	-	10	-	
Asphalt or concrete (Constructor)	16,000	0.5	296	2,400	356	10	59	
TOTAL			4,258		2,336		852	



WATER RESOURCES TECHNICAL REPORT

1200 Vine Street

1200 – 1218 N Vine Street
6245 – 6247 W Lexington Avenue
Los Angeles, California 90038

Prepared For

*Vine Street Los Angeles Apartments, LLC
4601 Park Road, Suite 450
Charlotte, NC 28209*

Prepared By

Fuscoe Engineering, Inc.
600 Wilshire Blvd., Ste. 1470
Los Angeles, California 90017
213.988.8802
www.fuscoe.com

Project Manager:
Samson E. Kawjaree, PE
C-83863

Date Prepared: October 25, 2022

Job Number: 4103.001



TABLE OF CONTENTS

1.	INTRODUCTION	4
1.1	PROJECT DESCRIPTION.....	4
1.2	SCOPE OF WORK.....	5
2.	REGULATORY FRAMEWORK.....	6
2.1	SURFACE WATER HYDROLOGY	6
2.2	SURFACE WATER QUALITY.....	6
2.3	GROUNDWATER.....	10
3.	ENVIRONMENTAL SETTING	12
3.1	SURFACE WATER HYDROLOGY	12
3.1.1	REGIONAL.....	12
3.1.2	LOCAL.....	12
3.1.3	ON SITE.....	12
3.1.4	FEMA.....	14
3.2	SURFACE WATER QUALITY.....	14
3.2.1	REGIONAL.....	14
3.2.2	LOCAL.....	16
3.2.3	ON SITE.....	16
3.3	GROUNDWATER.....	16
3.3.1	REGIONAL.....	16
3.3.2	LOCAL.....	17
3.3.3	ON SITE.....	17
4.	PROJECT METHODOLOGY AND IMPLEMENTATIONS	18
4.1	CONSTRUCTION.....	18
4.1.1	SURFACE WATER HYDROLOGY AND QUALITY.....	18
4.1.2	GROUNDWATER HYDROLOGY.....	19
4.1.3	GROUNDWATER QUALITY.....	20
4.2	OPERATION	21
4.2.1	SURFACE WATER HYDROLOGY.....	21
4.2.2	SURFACE WATER QUALITY.....	22
4.2.3	GROUNDWATER HYDROLOGY.....	24
4.2.4	GROUNDWATER QUALITY.....	24
5.	CONCLUSIONS	25

LIST OF TABLES

Table 1 – Existing Drainage Conditions	13
Table 2 – Beneficial Uses.....	14
Table 3 – 303(d) Impairments.....	15
Table 4 – Total Maximum Daily Loads.....	16
Table 5 – Proposed Drainage Conditions	22
Table 6 – Existing vs. Proposed Drainage Conditions	22
Table 7 – Potential Pollutants	23

LIST OF ATTACHMENTS

Attachment A – Ballona Creek Watershed Map
Attachment B – Local Storm Drain System Exhibit
Attachment C – Existing On-Site Hydrology
Attachment D – HydroCalc Hydrology Results for Existing Site
Attachment E – FEMA Floodplain Map
Attachment F – 2020 California 303(d) List
Attachment G – Proposed On-Site Hydrology Map
Attachment H – HydroCalc Hydrology Results for Proposed Site
Attachment I – LA County GIS 85 th Percentile Map

1. INTRODUCTION

1.1 PROJECT DESCRIPTION

Vine Street Los Angeles Apartments, LLC (Applicant) is proposing to develop a new mixed-use residential development (Project) on an approximate 0.94-acre site, located at 1200 – 1218 N Vine Street and 6245 – 6247 W Lexington Avenue in the City of Los Angeles. The Project proposes an 8 – story structure with two levels of above ground parking. The Project will include 153 residential units (21 – Studio, 89 – 1 Bedroom, 43 – 2 Bedroom) on six levels of residential housing, 7,000 square feet of high-turnover sit-down restaurant areas, 13,919 square feet of amenity areas (indoor and outdoor open spaces and gym/fitness facility), and parking areas (78 – Residential Spaces, 15 – Commercial Spaces).

The existing Project Site consists of two, 1 – story concrete buildings with the remainder of the site being a paved surface parking lot. There are also existing concrete masonry unit perimeter walls and fencing that run along the entire western, and southern perimeters of the paved parking. Based upon the proposed building program, the existing building structure, foundations, parking lot surface, fencing, walls, gates, and all existing flatwork will need to be demolished. This includes the existing signs, guard post, handrails, ramps, and light fixtures within the parking lot area of the Project Site. The Project will consist of a redevelopment of the existing parking lot and commercial building into a multi-family mixed-use apartment and commercial building.

The project is bounded by a Commercial Development that continues to La Mirada Avenue to the North, Commercial and Residential Developments that continue to El Centro Avenue to the East, Lexington Avenue to the South, and Vine Street to the West.



Project Site: Thomas Grid - Page 593 – Grid F5

1.2 SCOPE OF WORK

As part of the California Environmental Quality Act (CEQA) analysis , this report will examine surface water quality, hydrology, and groundwater in both existing and Project buildout scenarios. The ultimate goal of this report is to determine the capacity of existing utilities to serve the Project area, and to assess any major changes to hydrologic resources that may occur under proposed conditions.

2. REGULATORY FRAMEWORK

2.1 SURFACE WATER HYDROLOGY

County of Los Angeles Hydrology Manual

The Project Site is located within the Ballona Creek Watershed, which covers approximately 130 square miles. The Los Angeles County Flood Control District (LACFCD) is responsible for providing flood protection, water conservation, recreation, and aesthetic enhancement within this entire watershed. The Los Angeles County Flood Control District (LACFCD) is responsible for providing flood protection, water conservation, recreation and aesthetic enhancement within this entire watershed. The Los Angeles County Department of Public Works (LACDPW) developed a Hydrology Manual (January 2006), which establishes the LACDPW hydrologic design procedures based on historic rainfall and runoff data collected within the County. The Project is required to utilize the 2006 Hydrology Manual and accompanying hydrologic tools including the HydroCalc Calculator to calculate existing and proposed discharges and volumes from the Project.

Los Angeles Municipal Code

Any proposed drainage improvements within the street right-of-way or any other property owned by, to be owned by, or under control of the City requires approval through the B-Permit process (Section 62.105, Los Angeles Municipal Code (LAMC)). Through the B-Permit process, storm drain installation plans which include any connections to the City's storm drain system from a property line to a catch basin or storm drainpipe, are subject to review and approval by the City of Los Angeles Department of Public Works, Bureau of Engineering.

2.2 SURFACE WATER QUALITY

Clean Water Act

In 1972, the federal Clean Water Act¹ (CWA) was established, which provided the regulatory framework for surface water quality protection. The United States Congress amended the CWA in 1987 to specifically regulate discharges to waters of the United States from public storm drain systems and storm water flows from industrial facilities, including construction sites, and require such discharges be regulated through permits under the National Pollutant Discharge Elimination System (NPDES).² CWA regulation calls for the implementation of Best Management Practices (BMPs) to reduce or prevent the discharge of pollutants from these activities to the Maximum Extent Practicable (MEP) for urban runoff and meeting the Best Available Technology Economically Achievable (BAT) and Best Conventional Pollutant Control Technology (BCT) standards for construction storm water. Regulations and permits have been implemented at the federal, state, and local level to form a comprehensive regulatory framework to serve and protect the quality of the nation's surface water resources.

The CWA Federal Anti-Degradation Policy [40 Code of Federal Regulations (CFR) Section 131.12] requires states to develop statewide anti-degradation policies and identify methods for implementing them.

¹ Also referred to as the Federal Water Pollution Control Act of 1972.

² CWA Section 402(p).

Pursuant to the CFR, state anti-degradation policies and implementation methods shall, at a minimum, protect and maintain (1) existing in-stream water uses; (2) existing water quality, where the quality of the water exceeds levels necessary to support existing beneficial uses, unless the state finds that allowing lower water quality is necessary to accommodate economic and social development in the area; and (3) water quality in waters considered an outstanding national resource.

Basin Plan for the Coastal Watersheds of Los Angeles and Ventura Counties

As required by the California Water Code (CWC), the LARWQCB has adopted a plan entitled "Water Quality Control Plan, Los Angeles Region: Basin Plan for the Coastal Watersheds of Los Angeles and Ventura Counties" (Basin Plan). Specifically, the Basin Plan designates beneficial uses for surface and groundwaters, sets narrative and numerical objectives that must be attained or maintained to protect the designated beneficial uses and conform to the state's anti-degradation policy, and describes implementation programs to protect all waters in the Los Angeles Region. In addition, the Basin Plan incorporates (by reference) all applicable state and regional board plans and policies and other pertinent water quality policies and regulations. Those of other agencies are referenced in appropriate sections throughout the Basin Plan.

The General Permit for Construction Activities

SWRCB Order No. 2009-0009-DWQ known as the "Construction General Permit" was adopted on September 2, 2009 and was amended by Order No. 2010-0014-DWQ on February 14, 2011 and Order No 2012-0006-DWQ which became effective on July 17, 2012. This NPDES permit establishes a risk-based approach to stormwater control requirements for construction projects by identifying three project risk levels. The main objectives of the General Permit are to:

- Reduce erosion
- Minimize or eliminate sediment in stormwater discharges
- Prevent materials used at a construction site from contacting stormwater
- Implement a sampling and analysis program
- Eliminate unauthorized non-stormwater discharges from construction sites
- Implement appropriate measures to reduce potential impacts on waterways both during and after construction of projects
- Establish maintenance commitments on post-construction pollution control measures

California mandates requirements for all construction activities disturbing more than one acre of land to develop and implement Stormwater Pollution Prevention Plans (SWPPPs). The SWPPP documents the selection and implementation of BMPs for a specific construction project, charging owners with stormwater quality management responsibilities. A construction site subject to the General Permit must prepare and implement a SWPPP that meets the requirements of the General Permit.

As part of the Project, preparation, and implementation of a SWPPP will not be required, as the Project Site is under one acre (lot area is 0.936 acres).

Los Angeles County Municipal Storm Water System (MS4) Permit

As described above, USEPA regulations require that MS4 permittees implement a program to monitor and control pollutants being discharged to the municipal system from both industrial and commercial projects that contribute a substantial pollutant load to the MS4. On December 13, 2001, the NPDES

Permit or MS4 permit were adopted for municipal stormwater and urban runoff discharges within Los Angeles County, covering 84 cities and most of the unincorporated areas of Los Angeles County. The requirements of this Order (the "Permit") cover 84 cities and most of the unincorporated areas of Los Angeles County. Under the Permit, LACFCD is designated as the Principal Permittee. The 84 Los Angeles County cities (including the City of Los Angeles) and unincorporated areas within Los Angeles County are the "Co-Permittees". The Principal Permittee helps to facilitate activities necessary to comply with the requirements outlined in the Permit but is not responsible for ensuring compliance of any of the Permittees.

Since adoption of Order No. 01-182, the LARWQCB has adopted Order No. R4-2012-0175, as amended by State Water Board Order WQ 2015-0075 NPDES Permit No. CAS004001 on November 8, 2012. This current permit continues to serve as guiding documentation for the region while a new permit is developed. As a Co-Permittee, the City of Los Angeles is subject to the requirements set forth in Order No. R4-2012-0175, as amended by State Water Board Order WQ 2015-0075, NPDES Permit No. CAS004001.

Los Angeles Municipal Code

Section 64.70 of LAMC sets forth the City's Stormwater and Urban Runoff Pollution Control Ordinance. The ordinance prohibits the discharge of the following items into any storm drain systems:

- Any liquids, solids, or gasses which by reason of their nature or quantity are flammable, reactive, explosive, corrosive, or radioactive, or by interaction with other materials could result in fire, explosion or injury.
- Any solid or viscous materials, which could cause obstruction to the flow or operation of the storm drain system.
- Any pollutant that injures or constitutes a hazard to human, animal, plant or fish life, or creates a public nuisance.
- Any noxious or malodorous liquid, gas, or solid in sufficient quantity, either singly or by interaction with other materials, which creates a public nuisance, hazard to life, or inhibits authorized entry of any person into the storm drain system.
- Any medical, infectious, toxic or hazardous material or waste.

Earthwork activities, including grading, are overseen by the Los Angeles Building Code, which is contained in LAMC, Chapter IX, Article 1. Section 91.7013 contains regulations pertaining to erosion control and drainage devices and Section 91.7014 provide requirements for flood, mudflow protection and general construction requirements.

Low Impact Development

LID is a stormwater strategy that is used to mitigate the impacts of runoff and stormwater pollution as close to its source as possible. Urban runoff discharged may contain pollutants such as trash and debris, bacteria and viruses, oil and grease, sediments, nutrients, metals, and toxic chemicals that can negatively affect the ocean, rivers, plant and animal life, and public health. LID encompasses a set of site design approaches and BMPs that are designed to address runoff and pollution at the source. These LID practices can effectively remove nutrients, bacteria, and metals, while reducing the volume and intensity of stormwater flows.

The Project is subject to runoff mitigation in a manner that captures or treats rainwater at its source, while utilizing natural resources. Stormwater runoff shall either be infiltrated, evapotranspired, captured

and used, or treated through high removal efficiency BMPs, onsite, through stormwater management techniques that comply with provisions of the City of Los Angeles Planning and Land Development Handbook for Low Impact Development (May 2016). The LARWQCB has a BMP Hierarchy in which the project must follow when selecting the type or types of BMPs to be constructed on site. The following is the BMP Hierarchy, per Order No. R4-2012-0175 as amended by Order WQ 2015-0075 NPDES NO. CAS004001:

1. On-site infiltration,
2. On-site bioretention and/or harvest and use,
3. On-site biofiltration, off-site ground water replenishment, and/or off-site retrofit

Hydromodification

In addition to the LID requirements listed in the MS4 Permit, the Permit also addresses requirements for Hydromodification as pertaining to the project. Per Part VI.D.7.c.iv of the Permit:

Each Permittee shall require all New Development and Redevelopment projects located within natural drainage systems as described in Part VI.D.7.c.iv.(1)(a)(iii) to implement hydrologic control measures, to prevent accelerated downstream erosion and to protect stream habitat in natural drainage systems. The purpose of the hydrologic controls is to minimize changes in post-development hydrologic storm water runoff discharge rates, velocities, and duration. This shall be achieved by maintaining the project's pre-project stormwater runoff flow rates and durations.

However, per Part VI.D.7.c.iv.(1)(b)(iv) of the Permit, the Project is exempt from such requirements as runoff from the Project Site is discharged directly via storm drain to a receiving water that is not susceptible to hydromodification impacts. Specifically, the Project Site discharges via storm drain into Ballona Creek, which is categorized as not susceptible to hydromodification. Therefore, the Project is not required to implement hydrologic control measures as mitigation for hydromodification impacts. In addition, implementation of the Project will result in a reduction of peak flows and volumes as compared to existing conditions, thereby satisfying hydromodification requirements in addition to the receiving water exemption.

Ballona Creek Watershed Enhanced Watershed Management Program

The County of Los Angeles, the City of Los Angeles and all other cities in the Los Angeles Watershed are responsible for the implementation of watershed improvement plans or Enhanced Watershed Management Programs (EWMP) to improve water quality and assist in meeting the Total Maximum Daily Load (TMDL) milestones. An EWMP for the Ballona Creek Watershed was approved on April 20, 2016 (BC EWMP, January 2016), prepared with the City of Los Angeles as the lead coordinating agency, is in the process of review by the LARWQCB. The objective of the EWMP Plan is to determine the network of control measures (often referred to as best management practices [BMPs]) that will achieve required pollutant reductions while also providing multiple benefits to the community and leveraging sustainable green infrastructure practices (BC EWMP, January 2016).

The EWMP identifies a toolbox of distributed and regional watershed control measures to address applicable stormwater quality regulations including the following:

- LID at the individual parcels
- Green Streets features within the public right-of-way and privately maintained streets

- Regional projects that retain and treat runoff from large upstream areas
- Institutional control measures to prevent transport of pollutants in the watershed

The Project Site, located in the Ballona Creek watershed, falls within the BC EWMP and ultimately discharges into the Ballona Creek Estuary. The BC EWMP does not identify any regional BMP projects in the vicinity of the Project. Therefore, LID BMP's will be implemented at the individual parcels associated with the Project to meet the local MS4 Permit requirements and remain consistent with the objectives of the BC EWMP.

2.3 GROUNDWATER

California Groundwater Sustainability Act

On Sept. 16, 2014, California Governor Jerry Brown signed into law a three-bill legislative package, known as the Sustainable Groundwater Management Act of 2014 (SGMA). The SGMA provides a framework for sustainable management of groundwater supplies by local authorities, with a limited role for state intervention only if necessary, to protect the resource.

The SGMA requires the formation of local groundwater sustainability agencies (GSAs) that must assess conditions in their local water basins and adopt locally based management plans. The act provides substantial time – 20 years – for GSAs to implement plans and achieve long-term groundwater sustainability. It protects existing surface water and groundwater rights and does not impact current drought response measures.

The California Water Commission (CWC) requires a statewide prioritization of California's groundwater basins using the following eight criteria:

1. Overlying population;
2. Projected growth of overlying population;
3. Public supply wells;
4. Total wells;
5. Overlying irrigated acreage;
6. Reliance on groundwater as the primary source of water;
7. Impacts on the groundwater—including overdraft, subsidence, saline intrusion, and other water quality degradation;
8. Any other information determined to be relevant by the Department.

The Project Site is not located within a high priority California Statewide Groundwater Elevation Monitoring groundwater basin. It is located within the Coastal Plain of Los Angeles Groundwater Basin, in the Hollywood Subbasin, which currently does not have any California Statewide Groundwater Elevation Monitoring System wells. The subbasin is under the Los Angeles GSA, but there are currently no GSPs which include this location.^{3,4} GSAs responsible for high-and medium-priority basins must adopt groundwater sustainability plans within five to seven years. Plans must include a physical description of the basin, including groundwater levels, groundwater quality, subsidence, information on

³ <https://sgma.water.ca.gov/portal/gsa/all>

⁴ <https://sgma.water.ca.gov/portal/gsp/status>

groundwater-surface water interaction, data on historical and projected water demands and supplies, monitoring and management provisions, and a description of how the plan will affect other plans, including city and county general plans. Plans will be evaluated every five years.

Basin Plan for the Coastal Watersheds of Los Angeles and Ventura Counties

As required by the CWC, the LARWQCB has adopted a plan entitled “Water Quality Control Plan, Los Angeles Region: Basin Plan for the Coastal Watersheds of Los Angeles and Ventura Counties” (Basin Plan). Specifically, the Basin Plan designates beneficial uses for surface and groundwaters, sets narrative and numerical objectives that must be attained or maintained to protect the designated beneficial uses and conform to the state's anti-degradation policy and describes implementation programs to protect all waters in the Los Angeles Region. In addition, the Basin Plan incorporates (by reference) all applicable state and regional board plans and policies and other pertinent water quality policies and regulations. Those of other agencies are referenced in appropriate sections throughout the Basin Plan.

The Basin Plan is a resource for the LARWQCB and others who use water and/or discharge wastewater in the Los Angeles Region. Other agencies and organizations involved in environmental permitting and resource management activities also use the Basin Plan. Finally, the Basin Plan provides valuable information to the public about local water quality issues.

3. ENVIRONMENTAL SETTING

3.1 SURFACE WATER HYDROLOGY

3.1.1 REGIONAL

The Project Site is located within the Ballona Creek Watershed, which covers approximately 130 square miles. The watershed includes the cities of Beverly Hills, West Hollywood, portions of the cities of Los Angeles, Culver City, Inglewood and Santa Monica, unincorporated areas of Los Angeles County, and areas under the jurisdiction of Caltrans. Ballona Creek flows as an open channel for just under 10 miles from mid-Los Angeles (south of Hancock Park) through Culver City, reaching the Pacific Ocean at Playa del Rey (Marina del Rey Harbor). Ballona Creek watershed is highly developed with 49% of the watershed covered by impervious surfaces.

Major tributaries of Ballona Creek include Centinela Creek, Sepulveda Channel and Benedict Canyon Channel. The Project falls within the Ballona Creek Watershed (See **Attachment A – Ballona Creek Watershed Map**) for a map of the watershed.

3.1.2 LOCAL

Stormwater runoff is collected from the Project Site and conveyed through an offsite storm drain facility along Vine Street, with excess stormwater flowing further down to El Centro Avenue. Existing city records per NavigateLA, and per a Project Site visitation, indicate that there is one (1) existing 7-foot diameter storm drain in Vine St resides west of the Project. The storm drain on Vine Street is owned and maintained by the City of Los Angeles. This 84-inch (7-foot) main line in Vine Street flows in a southwesterly direction and discharges into Ballona Creek Reach 1.

There are two (2) existing catch basins at the southwest corner of the project site, the intersection between Vine Street and Lexington Avenue (one on each respective street). Excess flows from Vine Street and along Lexington Avenue discharge towards these catch basins. The two catch basins connect to the 84-inch storm drain pipe along Vine Street through a 12-inch storm drain pipe, which ultimately flow south. These drains eventually discharge into Ballona Creek Reach 1 (See **Attachment B – Local Storm Drain System Exhibit**).

All the stormwater runoff from the Project Site, which is within Ballona Creek watershed, is discharged into Ballona Creek Reach 1 which makes its way to the Ballona Creek Estuary and ultimately into the Pacific Ocean. Ballona Creek Reach 1 is approximately 2 miles long, spanning from Cochran Avenue to National Boulevard and covering areas above National Boulevard. It includes the Los Angeles neighborhoods of West Hollywood and portions of other cities of Los Angeles County.

3.1.3 ON SITE

The existing Project Site consists of one (1) retail/commercial structure with the remainder of the site being mostly paved as a surface parking lot. Stormwater runoff is collected and conveyed on all adjacent streets, Vine Street and Lexington Avenue fronting the Project Site, on the westerly and southerly edges of the project, respectively. The parking area sheet flows down sloped drive aisles and gravity flow into

a catch basin along the easterly edge of Vine Street, or to the catch basin along Lexington Avenue. There is no known drain located in the parking lot area. The city owned 12-inch storm drain line from the catch basins on Vine Street and Lexington Avenue connect and discharge into a city owned 84-inch main line in Vine Street. The existing drainage pattern and existing hydrology of the Project Site have been mapped out (See **Attachment C – Existing On-Site Hydrology Map**).

Table 1 provides the 10-year, 25-year, and 50-year storm frequency analysis for the Project Site’s existing conditions, using the post-dedication acreage. The existing imperviousness was obtained from Appendix D (Proportion Impervious Data) of the LACDPW Hydrology Manual (2006).

Hydrology analysis was conducted at the Project Site to determine any increases in peak flows during the 10-year, 25-year, and 50-year storm event in the existing and proposed conditions. See **Table 1** below for the existing conditions hydrology analysis results. Output hydrology calculations are provided (See **Attachment C – HydroCalc Hydrology Results for Existing Site**). The existing hydrology calculations were based on the gross area of the existing project site, which includes any dedications and or easements within the property. For an analysis comparing existing peak flows to proposed peak flows refer to Section 4.2.1.

Table 1 – Existing Drainage Conditions

Drainage Area	Area (acres)	% Imperviousness	Q10 (cfs)	Q25 (cfs)	Q50 (cfs)
A-1 (Vine Street)	0.33	100	0.68	0.91	1.04
A-2 (Vine Street)	0.44	97.3	0.89	1.10	1.25
A-3 (Lexington Avenue)	0.28	100	0.63	0.77	0.88
TOTAL	1.01	99.1	2.20	2.78	3.17

Under existing conditions, the Project Site discharges southerly into Lexington Avenue and westerly into Vine Street. The Vine Street runoff (Drainage Area A-1 and A-2) discharges into a 3.5-foot wide curbside catch basin approximately 15-feet west of the project site. The Lexington Avenue runoff (Drainage Area A-3) discharges into a a 3.5-foot wide curbside catch basins approximately 12-feet south of the project site. A portion of the project runoff from the Project Site is captured by the catch basin located along Lexington Avenue and a majority of the project site flows into Vine Street which both converge into a catch basin along Vine Street. These runoff values were calculated using the gross area of the project site as the pervious areas were both inside and outside the project’s property line.

The total amount of runoff produced from the Drainage Area A-1 during 10-year, 25-year, and 50-year storm events are 0.68 cfs, 0.91 cfs, and 1.04 cfs respectively. The total amount of runoff produced from the Drainage Area A-2 during 10-year, 25-year, and 50-year storm events are 0.89 cfs, 1.10 cfs, and 1.25 cfs respectively. The total amount of runoff produced from the Drainage Area A-3 during 10-year, 25-year, and 50-year storm events are 0.63 cfs, 0.77 cfs, and 0.88 cfs respectively. The gross area was used to calculate the runoff values in the existing conditions to compare the pervious areas more conservatively against the proposed conditions. Using the net area of the project site would produce a lower pervious area, creating a greater increase in pervious areas when compared to proposed conditions. This would result in a greater reduction of runoff when comparing existing versus proposed,

in favor of the proposed Project. There are no known existing storm drain deficiencies or capacity issues within the storm drains that collect runoff from the Project Site. The Stormwater Division has mentioned that if the project is reducing the stormwater runoff, the City of Los Angeles does not anticipate conflicts. There are no known existing storm drain deficiencies or capacity issues within the storm drains that collect runoff from the Project Site. If the Project is reducing the stormwater runoff, the City does not anticipate any conflicts.

3.1.4 FEMA

According to the Federal According to the Federal Emergency Management Agency’s (FEMA) Flood Insurance Rate Map (FIRM) No. 06037C1605F, dated September 26, 2008, the Project Site is located within Zone X outside of the 0.2% chance of flooding. Zone X depicts areas determined to be outside the 0.2% (500-year) annual chance floodplain. Therefore, the processing of a letter of map revision or conditional letter of map revision (LOMR/CLOMR) through FEMA will not be required for the Project (See **Attachment E – FEMA Floodplain Map**).

3.2 SURFACE WATER QUALITY

3.2.1 REGIONAL

As described above, the Project Site is located within the Ballona Creek watershed. This portion of the watershed drains directly into Reach 1 of the Ballona Creek. Ballona Creek Reach 1 is an impaired portion of the Ballona Creek and primarily includes the Los Angeles neighborhoods of West Hollywood and other portions of other cities of Los Angeles County. Ballona Creek consists of a concrete channel, with the water generally restricted to a central low-flow channel.

3.2.1.1 Beneficial Uses in Ballona Creek Reach 1/Ballona Creek Watershed

Beneficial uses exist for Ballona Creek Reach 1. The existing and potential beneficial uses for the waters within the Ballona Creek Reach 1, where the majority of surface water flows from the Project ultimately discharge are described below.

Table 2 – Beneficial Uses

Beneficial Uses, Ballona Creek Reach 1	
MUN** - Municipal and Domestic Supply	WILD* - Wildlife Habitat
REC1** - Water Contact Recreation	REC2* - Non-Contact Water Recreation
WARM** - Warm Freshwater Habitat	
Notes: * Existing beneficial use ** Potential beneficial use Source: Los Angeles Regional Water Quality Control Board Beneficial Use Table, found here: http://www.waterboards.ca.gov/losangeles/water_issues/programs/basin_plan/Beneficial_Uses/ch2/Revised%20Beneficial%20Use%20Tables.pdf	

See the source note in Table 2 for a table containing beneficial uses for all reaches of the Ballona Creek Reach 1 that the Project ultimately discharges into downstream.

3.2.1.2 Impairments and TMDL's in Ballona Creek Reach 1/Ballona Creek Watershed

CWA 303(d) List of Water Quality Limited Segments

Under Section 303(d) of the CWA, states are required to identify water bodies that do not meet their water quality standards. Biennially, the LARWQCB prepares a list of impaired waterbodies in the region, referred to as the 303(d) list. The 303(d) list outlines the impaired waterbody and the specific pollutant(s) for which it is impaired. All waterbodies on the 303(d) list are subject to the development of total maximum daily loads (TMDL).

Table 3 – 303(d) Impairments

Water Body	303(d) Impairment
Ballona Creek	Copper, Cyanide, Indicator Bacteria, Lead, Toxicity, Trash, Viruses (enteric), Zinc
Ballona Creek Estuary	PCBs (Polychlorinated biphenyls), Zinc, Chlordane, Indicator Bacteria, DDT (Dichlorodiphenyltrichloroethane), Cadmium, PAHs (Polycyclic Aromatic Hydrocarbons), Silver, Toxicity, Copper, Lead
Santa Monica Bay Offshore/Nearshore	Arsenic, DDT, Mercury, PCBs, Trash
Notes: Source: 2020 - 2022 California Integrated Report (Clean Water Act Section 303(d) List / 305(b) Report), found here: https://www.waterboards.ca.gov/water_issues/programs/tmdl/2020_2022state_ir_reports_revised_final/apx-c-catreports/category5_report.shtml	

The proposed capture and use BMPs for the project shall adequately treat any additional source of pollutants associated with the project. With the implemented BMPs, the additional pollutants will be treated and will not have a significant effect on the downstream receiving waters.

Total Maximum Daily Loads (TMDLs)

Once a water body has been listed as impaired on the 303(d) list, a TMDL for the constituent of concern (pollutant) must be developed for that water body. A TMDL is an estimate of the daily load of pollutants that a water body may receive from point sources, non-point sources, and natural background conditions (including an appropriate margin of safety), without exceeding its water quality standard. Those facilities and activities that are discharging into the water body, collectively, must not exceed the TMDL. In general terms, municipal, small MS4, and other dischargers within each watershed are collectively responsible for meeting the required reductions and other TMDL requirements by the assigned deadline. TMDLs for water bodies tributary to the Project Site are listed in Table 4.

Table 4 – Total Maximum Daily Loads

Water Body	303(d) Impairment
Ballona Creek	Copper, Cyanide, Indicator Bacteria, Lead, Toxicity, Trash, Viruses (enteric), Zinc
Ballona Creek Estuary	PCBs, Zinc, Chlordane, Indicator Bacteria, DDT, Cadmium, PAHs, Silver, Toxicity, Copper, Lead
Santa Monica Bay Offshore/Nearshore	DDT, PCBs, Trash
Notes: Source: 2020 - 2022 California Integrated Report (Clean Water Act Section 303(d) List / 305(b) Report), found here: https://www.waterboards.ca.gov/rwqcb5/water_issues/tmdl/impaired_waters_list/	

3.2.2 LOCAL

Within the urban environment of the Project, stormwater runoff occurs during and shortly after rain events. The volume of runoff depends on the intensity and duration of the storm event and the imperviousness of the drainage area. Typical urban pollutants associated with stormwater runoff following rain events includes sediment, trash, bacteria, metals, nutrients, and potentially organics and pesticides. The source of contaminants is wide ranging and includes all areas where rainfall occurs along with atmospheric deposition. Therefore, sources of contaminants within urban areas include roadways, building tops, parking lots, landscape areas and maintenance areas.

To reduce contaminant loads from entering the storm drain system, the City conducts routine street cleaning operations as well as periodic cleaning and maintenance of the catch basins to reduce stormwater pollution within the storm drain system. The City also installs catch basin screens to reduce trash from entering the catch basins.

3.2.3 ON SITE

Under existing conditions, the Project Site is commercial, with associated parking areas. Based on visual inspection, water quality treatment control BMP's are not currently present at the Project Site. Stormwater leaves the Project Site via an existing catch basin, existing drains, roof drains which penetrate the finished surface, or exits onto adjacent streets and remains untreated. Ultimately flows discharge into curbside inlets on southernly edge Lexington Avenue or the westerly edge of Vine Street where it gets picked up by the public storm drain system. Anticipated pollutants consistent with parking lots, building areas and landscaping include total suspended solids (TSS), oil/grease, heavy metals, nutrients, pesticides and trash.

3.3 GROUNDWATER

3.3.1 REGIONAL

The City of Los Angeles overlies the Los Angeles Coastal Plain Groundwater Basin (Basin) which consists of four major subbasins: Hollywood, Santa Monica, Central and West Coast. Replenishment of the Basin occurs primarily through percolation of rainfall throughout the watershed via permeable surfaces, spreading grounds, and groundwater migration from adjacent basins. Injection wells are also used to

pump freshwater along specific seawater barriers to prevent the intrusion of salt water. Groundwater within the Basin generally flows in a south and southwesterly direction.

3.3.2 LOCAL

The Project Site is located within the Hollywood subbasin, which underlies along the northeastern part of the Los Angeles Coastal Plain Groundwater Basin. This subbasin reside in the Los Angeles GSA, which does not currently have a GSP for the basin. The subbasin is bounded on the north by Santa Monica Mountains and the Hollywood fault, on the east by the Elysian Hills, on the west by the Inglewood fault zone, and on the south by the La Brea High, formed by an anticline that brings impermeable rocks close to the surface. Groundwater in the Hollywood Subbasin is mainly produced from Pleistocene age alluvial sands and gravels.⁵

According to the California Department of Water Resources, the annual precipitation throughout the Hollywood subbasin ranges from 12 to 14 inches with an average of around 13 inches. The Hollywood subbasin has a surface area of 10,500 acres and a groundwater storage capacity of approximately 200,000 acre/feet.⁶ Historically, groundwater flow is generally westward through the subbasin toward the Inglewood fault. Recharge of the Hollywood Subbasin occurs primarily by percolation of precipitation and stream flow from the higher areas to the north. Subsurface inflow may take place to a limited extent from underflow through fractured rock of the Santa Monica Mountains and potentially from underflow around the La Brea High.

3.3.3 ON SITE

As noted by Geotechnologies, Inc's geotechnical report for the Project dated December 9, 2021, the California Geological Survey Seismic Hazard Evaluation Report 026 Plate 1.2 entitled "Historically Highest Ground Water Contours" indicates that the historically high groundwater level in the area is approximately 37 feet below the ground surface. Groundwater was encountered at depths between 20 and 21.5 feet below the ambient site grade in exploratory excavations.

The closest neighboring active monitoring wells to the project site is Well Number 2671A with a groundwater depth of 22 ft and a water surface elevation of 261.60 ft (recorded 01.24.2022), located approximately 0.6 miles southeast of the project site.

There is not a high potential for contaminated soils to be encountered, but if the contaminated soils are found within the excavation limits, contaminated soils would be collected within the excavated material, removed from the Project Site, and disposed of in accordance with all applicable regulatory requirements.

⁵ California's Groundwater, Bulletin 118. Department of Water Resources. February 2004.

⁶ California's Groundwater, Bulletin 118. Department of Water Resources. February 2004.

4. PROJECT METHODOLOGY AND IMPLEMENTATIONS

4.1 CONSTRUCTION

4.1.1 SURFACE WATER HYDROLOGY AND QUALITY

Implementation of the Project would result in construction activities that includes demolition of the existing buildings and parking areas on-site and over-excavation of existing soils. It is anticipated that the Project would result in the import of 0 cubic yards and the excavation of approximately 10,000 cubic yards of soil. The excavated materials will be hauled via the nearby 101 Freeway with the ultimate destination at the Azusa Land Reclamation CO. Landfill in the City of Azusa.

Construction activities have the potential to temporarily alter the existing drainage patterns of the Project Site and also increase the permeability of the site based on increased pervious surface coverage during construction. Exposed pervious surfaces also have the potential for erosion, scour, and increased sediment and associated pollutants discharging from the Project Site during construction activities. The main pollutant of concern during construction is typically sediment and soil particles that discharge off-site due to wind, rain, and construction patterns. In the event exceedances of receiving water quality objectives are observed, measures must be taken and documented within the SWPPP to improve discharge water quality and runoff effluent. This may include but not be limited to increasing the size of existing BMPs, adding more BMPs to the drainage area, additional filtering, and/or a reduction in active grading area.

Construction Best Management Practices (BMPs)

Prior to commencement of construction activities, the General Permit requires the following Permit Registration documents:

- Notice of Intent (NOI);
- Risk Assessment (Standard or Site-Specific);
- Particle Size Analysis (if site-specific risk assessment is performed);
- Site Map;
- SWPPP;
- Annual Fee & Certification.

Prior to commencement of construction activities, the General Permit requires the Project SWPPP to be prepared in accordance with the site-specific information including grading limits, BMP's for each phase, schedule and sediment risk analyses. In accordance with the General Permit, the construction SWPPP must be made available for review upon request, shall describe construction BMPs that address pollutant source reduction, and provide measures/controls necessary to mitigate potential pollutant sources. These measures/controls include, but are not limited to: erosion controls, sediment controls, tracking controls, non-storm water management, materials & waste management, and good housekeeping practices including the following:

- Erosion control BMPs, such as hydraulic mulch, soil binders, and geotextiles and mats, protect the soil surface by covering and/or binding the soil particles. Temporary earth dikes or drainage swales may also be employed to divert runoff away from exposed areas and into more suitable locations. If implemented correctly, erosion controls can effectively reduce the sediment loads entrained in storm water runoff from construction sites.

- Sediment controls are designed to intercept and filter out soil particles that have been detached and transported by the force of water. Storm drain inlets on the Project Site or within the project vicinity (i.e., along streets immediately adjacent to the project boundary) should be adequately protected with an impoundment (i.e., gravel bags) around the inlet and equipped with a sediment filter (i.e., fiber roll). Bags should also be placed around areas of soil disturbing activities, such as grading or clearing.
- Stabilize construction entrance/exit points to reduce the tracking of sediments onto adjacent streets. Wind erosion controls should be employed in conjunction with tracking controls.
- Non-storm water management BMPs prohibit the discharge of materials other than storm water, as well as reduce the potential for pollutants from discharging at their source. Examples include avoiding paving and grinding operations during the rainy season (i.e., October 1 through April 30 each year) where feasible, and performing any vehicle equipment cleaning, fueling and maintenance in designated areas that are adequately protected and contained.
- Waste management consists of implementing procedural and structural BMPs for collecting, handling, storing and disposing of wastes generated by a construction project to prevent the release of waste materials into storm water discharges.

The applicant is not required by the City to provide a Notice of Intent, WDID issued from the SWRCB, or SWPPP to ensure the potential for soil erosion and construction are minimized, due to the Project disturbing less than one (1) acre of land (lot area is 0.936 acres)..

The phases of construction will define the maximum amount of soil disturbed, the appropriately sized sediment basins, and other control measures to accommodate all active soil disturbance areas and the appropriate monitoring and sampling plans.

Potential Surface Water Hydrology and Quality Impacts

Through compliance with the General Permit including implementation of BMPs appropriate for each major phase of construction, and compliance with applicable City grading regulations, construction of the Project would not cause flooding, substantially increase or decrease the amount of surface water in a water body, or result in a permanent, adverse change to flow direction. The construction of the Project would also not result in discharges that would cause: (1) pollution that would impact the quality of waters of the state to a degree which negatively impacts beneficial uses of the waters; (2) contamination of the quality of the waters of the state by waste to a degree which creates a hazard to the public health through poisoning or through the spread of diseases; or (3) nuisance that would be injurious to health, affect an entire community or neighborhood or any considerable number of persons, and occurs during or as a result of the treatment or disposal of wastes. Lastly, construction of the Project would not result in discharges that would cause regulatory impacts within Ballona Creek. Therefore, it is anticipated that surface water hydrology and water quality during construction will be properly accounted for. Additionally, effects to surface water hydrology and water quality during construction would therefore be less than significant.

4.1.2 GROUNDWATER HYDROLOGY

Construction of the Project is not anticipated to impact any water supply wells, as no water supply wells are located at or within half a mile downstream of the Project and the Project will not include the construction of any water supply wells. Construction of the Project is not anticipated to impact any water

supply wells, as no active water supply wells are located at or within half a mile downstream of the Project and the Project will not include the construction of any water supply wells. Construction of the Project will include excavation depths of approximately 5 to 7 feet bgs in some of the elevated areas. Based on Geotechnologies' Geotechnical Report (December 9, 2021), the historical high groundwater level in the area is 37 feet bgs. Groundwater was encountered during exploration with boring samples explored between 20 ft and 21.5 ft below grade. Since most of the structure will be above a surface elevation of 311 to 316 feet (based on ALTA surface elevations, dated 10/21/2021), it is not expected that groundwater would be encountered during construction that would require temporary or permanent dewatering operations. In the event perched groundwater is encountered, the Project would be required to obtain a temporary dewatering permit from the City of Los Angeles. If dewatering were to occur on the site, the water quality must first be assessed, and the California State Warning Center (CSWC) should be contacted for assistance. Depending on the quality of water and with the CSWC's assistance, the dewatered water may be managed within this project site, discharged to a sanitary sewer, transported for off-site treatment, used at a separate facility, used on adjacent land, or additional BMPs may be required and the treated water would be discharged into a storm drain or nearing water body. Accordingly, construction of the Project will not adversely impact the rate or direction of flow of groundwater, and the Project potential impacts on groundwater hydrology during construction have been taken into consideration.

4.1.3 GROUNDWATER QUALITY

The significance of the Project Site as it relates to the condition of the underlying groundwater table included a review of the following existing considerations:

- Identification of the Hollywood Subbasin as the underlying groundwater basin, and description of the level, quality, direction of flow, and existing uses for the groundwater
- Description of the location, existing uses, production capacity, quality and other pertinent data for spreading grounds and potable water wells in the vicinity (typically within a one-mile radius);

The analysis of the Project's impacts on groundwater conditions included a review of the following proposed considerations:

- Description of the rate, duration, location and quantity of extraction, dewatering, spreading, injection or other activities;
- The projected reduction in groundwater resources and any existing wells in the vicinity (typically within one-mile radius); and
- The projected change in local or regional groundwater flow patterns.

In addition, short-term groundwater quality impacts regarding soils and shallow groundwater exposure to construction materials, wastes, and spilled materials will be accounted for and the site will deploy proper housekeeping measures.

As previously noted above, construction of the Project will include excavation of approximately 5 to 7 feet bgs. The Project will also result in a net export of existing soil material. There is not a high potential for contaminated soils or groundwater to be encountered, but if contaminated soils are found within the excavation limits, contaminated soils would be collected within the excavated material, removed from the Project Site, and disposed of in accordance with all applicable regulatory requirements.

During on-site grading and building activities, minimal amounts of hazardous materials such as fuels, paints, solvents, and concrete additives could be used, and the presence of such materials provides an

opportunity for hazardous materials to be released into groundwater. To protect groundwater resources, the Project will comply with applicable federal, state and local requirements related to the handling, storage, application and disposal of hazardous waste which will reduce the potential for construction activities of the Project to release contaminants into groundwater that could affect existing contamination, mobilize or increase the level of groundwater contamination, or cause a violation of regulatory water quality standards at an existing production well. Therefore, groundwater contamination through hazardous materials releases, and impacts on groundwater quality have been taken into consideration, and should have no issues.

4.2 OPERATION

4.2.1 SURFACE WATER HYDROLOGY

In December 3, 1999, the City of Los Angeles issued Special Order No. 007-1299 which adopted the Los Angeles County Department of Public Works' Hydrology Manual to be used for hydrology studies within the City of Los Angeles. According to the County's Hydrology Manual, the Project is required to have drainage facilities that meet the Urban Flood level of protection, which is equivalent to runoff from a 25-year frequency design storm falling on a saturated watershed. A 25-year frequency design storm has a probability of 1/25 of being equaled or exceeded in any year.

In addition to the 25-year storm event, 10- and 50- year storm frequency analyses have been conducted for flood hazard and changes in the amount or movement of surface water.

This study was prepared using HydroCalc 1.0.2 software in conformance with the County's Hydrology Manual (2006). The HydroCalc program uses the Modified Rational Method to calculate the required time of concentration and designed flowrates for 10-, 25- and 50-year storm events. The peak runoff for a drainage area is calculated using the formula $Q = CIA$, where:

- Q = flowrate (cfs)
- C = runoff coefficient (unit less)
- I = rainfall intensity (in/hr)
- A = basin area (acres)

The HydroCalc calculator is supported by the County's online GIS system. This database is used to locate the Project Site's 85th percentile and 50-year isohyetal rainfall frequency as well as relevant soil type. The data collected is then used in the HydroCalc program to calculate peak stormwater runoff values.

Development of the Project would result in an increase in the landscaped areas throughout the Project Site and would increase the impervious surfaces from 99.1 percent to 85.3 percent. This increase in pervious surfaces would result in maintaining in stormwater runoff. The proposed drainage pattern and proposed hydrology of the Project Site have been mapped out (See **Attachment G – Proposed On-Site Hydrology Map**).

See Table 5 for the proposed conditions hydrology analysis results. Output hydrology calculations are provided (See **Attachment H – HydroCalc Hydrology Results for Proposed Site**). Table 5 below provides an analysis of a 10-year, 25-year and 50-year frequency design storm events following construction of the Project. For an analysis comparing existing peak flows to proposed peak flows refer to Table 6.

Table 5 – Proposed Drainage Conditions

Drainage Area	Area (acres)	% Imperviousness	Q10 (cfs)	Q25 (cfs)	Q50 (cfs)
A-1 (Vine Street)	0.93	85.3	2.05	2.53	2.90

Table 5 provides a comparison of the existing and proposed peak flows for the 10-year, 25-year and 50-year storm events. These values provide the basis for the LID design. The above analysis includes the assumption that less landscaped area shall be added within the property, thereby decreasing the pervious area of the Project Site. As shown in Table 5, the decrease in the permeable surfaces on the Project site would result in similar flows under a 10-year storm, under a 25-year storm, as well as under a 50-year storm event.

Table 6 – Existing vs. Proposed Drainage Conditions

Drainage Area Condition	Area (acres)	Q10 (cfs)	Q25 (cfs)	Q50 (cfs)
Existing	1.01	2.20	2.78	3.17
Proposed	0.93	2.05	2.53	2.90
Difference	-0.08	-0.15	-0.23	-0.27
% Change from Existing to Proposed Conditions	-7.9%	-6.8%	-8.9%	-8.5%

The above analysis includes the assumption that more landscaped area shall be added within the property, thereby increasing the pervious area of the Project site. As shown in Table 6, the increase in permeable surfaces on the Project Site would result in a reduction of flows under the 25-year storm and 50-year storm events for the Project.

Based on the above, operation of the Project would not result in flooding, impact of the capacity of the existing storm drain system, or worsen an existing flood condition. In addition, the Project would not substantially reduce or increase the amount of surface water in the local water body or result in a permanent adverse change in the drainage system. As flow are predicted to decrease, it is not anticipated that any deficiencies will be created or exacerbated by the Project on the existing open catch basins and the main 84-inch storm drain line on Vine Street. The capacity of the storm drain facilities, which the Project contributes to, will not be adversely impacted by the proposed change in flows. Therefore, operation of the Project should result in a less than significant effect on surface water hydrology.

4.2.2 SURFACE WATER QUALITY

Stormwater runoff from the Project has the potential to discharge pollutants into the City and County storm drain system. Anticipated pollutants and typical source of the pollutants are listed in Table 7.

Table 7 – Potential Pollutants

Potential Pollutants	Source of Pollutants
Sediment	Parking lots, driveways, building rooftops, landscape areas, road
Nutrients	Landscape areas, lawns
Pesticides	Landscape areas, lawns
Pathogens	Landscape areas, lawns, building rooftops
Trash/Debris	Parking lots, driveways, roadways, parks
Oil/Grease	Parking lots, driveways, roadways
Metals	Parking lots, driveways, roadways

To meet the local MS4 Permit and LID requirements consistent with the City’s LID Ordinance and LID Manual (May 9, 2016), stormwater management strategies will be implemented throughout the Project Site. Capture and use design features will be implemented to meet the local LID requirements.

Based on Geotechnologies’ Geotechnical Report (December 9, 2021), infiltration is not recommended. It is deemed infeasible due to the proposed structure, poor infiltration capabilities of the soils found within the project site, and groundwater table conditions, mentioned previously. A capture and use feasibility screening was performed following the criteria in the City of Los Angeles Low Impact Development (LID) Manual. After analyzing the landscaping type and coverage (approximately 10% pervious) and the Estimated Total Water Use (ETWU) at the Project Site, it was determined that capture and use BMPs may be feasible and may be designed and maintained to ensure adequate capacity to capture and disperse the stormwater design volume within the allotted time for capture.

The Project will comply with the City’s LID Manual,⁷ which requires that post-construction stormwater runoff from new developments be infiltrated, evapotranspired, captured and reused, and/or treated through a high efficiency BMP onsite for the 85th percentile storm event or 0.75”—whichever is greater. For the Project, the 85th percentile storm event is 0.98”. The LID Manual states that BMPs shall be designed to manage and capture stormwater runoff. Infiltration systems are the first priority type of BMP improvements as they provide for percolation and infiltration of the stormwater into the ground, which not only reduces the volume of stormwater runoff entering the MS4 but also contributes to groundwater recharge in some areas. The second priority BMP is capturing and reusing stormwater onsite for either landscape irrigation or toilet flushing. Projects that cannot infiltrate or harvest/reuse the water quality volume may implement biofiltration BMPs. Biofiltration BMPs shall be sized to adequately capture 1.5 times the volume not managed through infiltration and/or capture and reuse. The project will develop a LID plan to be submitted to the City as part of the final engineering of the project to satisfy water quality requirements of the Project Site. Infiltration will be implemented if feasible, otherwise capture and use will be assessed. If capture/use is infeasible, biotreatment BMPs will be implemented.

The existing Project Site has no known structural or LID BMPs to treat stormwater. Therefore, implementation of the LID features proposed as part of the Project would result in a significant

⁷ Planning and Land Development Handbook for Low Impact Development, Part B Planning Activities, 5th Edition; adopted by the City of Los Angeles, Board of Public Works on May 9, 2016.

improvement in surface water quality runoff as compared to existing conditions. Implementation of the proposed BMP system will result in the treatment of the entire required volume for the Project Site and the elimination of pollutant runoff up to the 85th percentile storm event.

Based on the proposed LID plan, operation of the Project would not result in discharges that would cause: (1) an incremental increase in pollution which would alter the quality of the waters of the state (Ballona Creek) to a degree which unreasonably affects beneficial uses of the waters; (2) an incremental increase of contamination of the quality of the waters of the state by waste to a degree which creates a hazard to the public health through poisoning or through the spread of diseases; or (3) an incremental increase in the nuisance that would be injurious to health; affect an entire community or neighborhood, or any considerable numbers of persons; and occurs during or as a result of the treatment or disposal of wastes. Lastly, operation of the Project would not result in discharges that would cause regulatory standards to be violated in the Ballona Creek. Thus, the Project's operational effects on surface water quality would be less than significant.

4.2.3 GROUNDWATER HYDROLOGY

Under the proposed conditions, regional and local potable water levels and adjacent wells or well fields will not be impacted by the Project. The Project does not include any groundwater pumping and relies on the LADWP for water. In addition, the Project is not anticipated to adversely change the rate of direction of flow of groundwater. Implementation of the Project would also result in an increase in pervious areas over the existing conditions. The increase in pervious areas would improve the groundwater recharge capacity of the Project Site over existing conditions. Since the Project is anticipated to implement LID BMPs to treat the required volume of runoff, the Project shall improve the existing groundwater hydrology. The Project's LID BMP design is for capture and reuse, treated runoff is stored within a cistern, and if to be utilized within the 7-month wet season period (October to April). Therefore, operational effects to groundwater hydrology are considered less than significant.

4.2.4 GROUNDWATER QUALITY

The SWRCB's Geotracker website indicates there are no significant sources of soil or groundwater pollution within the project area. The proposed LID BMP systems are designed to safely convey stormwater runoff into the sub-surface soil without the threat of contaminant mobilization, and will assist in improving the groundwater quality. Based on the design of the Project's capture and use system utilizing the stored stormwater for irrigation, operational effects to groundwater quality are considered less than significant.

5. CONCLUSIONS

The proposed Project will implement best management practices and will maximize landscaping in order to minimize effects to hydrology and surface water and groundwater quality. Under buildout conditions, flows are anticipated to remain similar or decrease and to be efficiently treated through LID treatment technologies. Based on the analysis contained in this report, less than significant effects have been identified for surface water hydrology, surface water quality, or groundwater for this project.

ATTACHMENT A

BALLONA CREEK WATERSHED MAP



COUNTY OF LOS ANGELES

BALLONA CREEK & OTHER URBAN WATERSHEDS

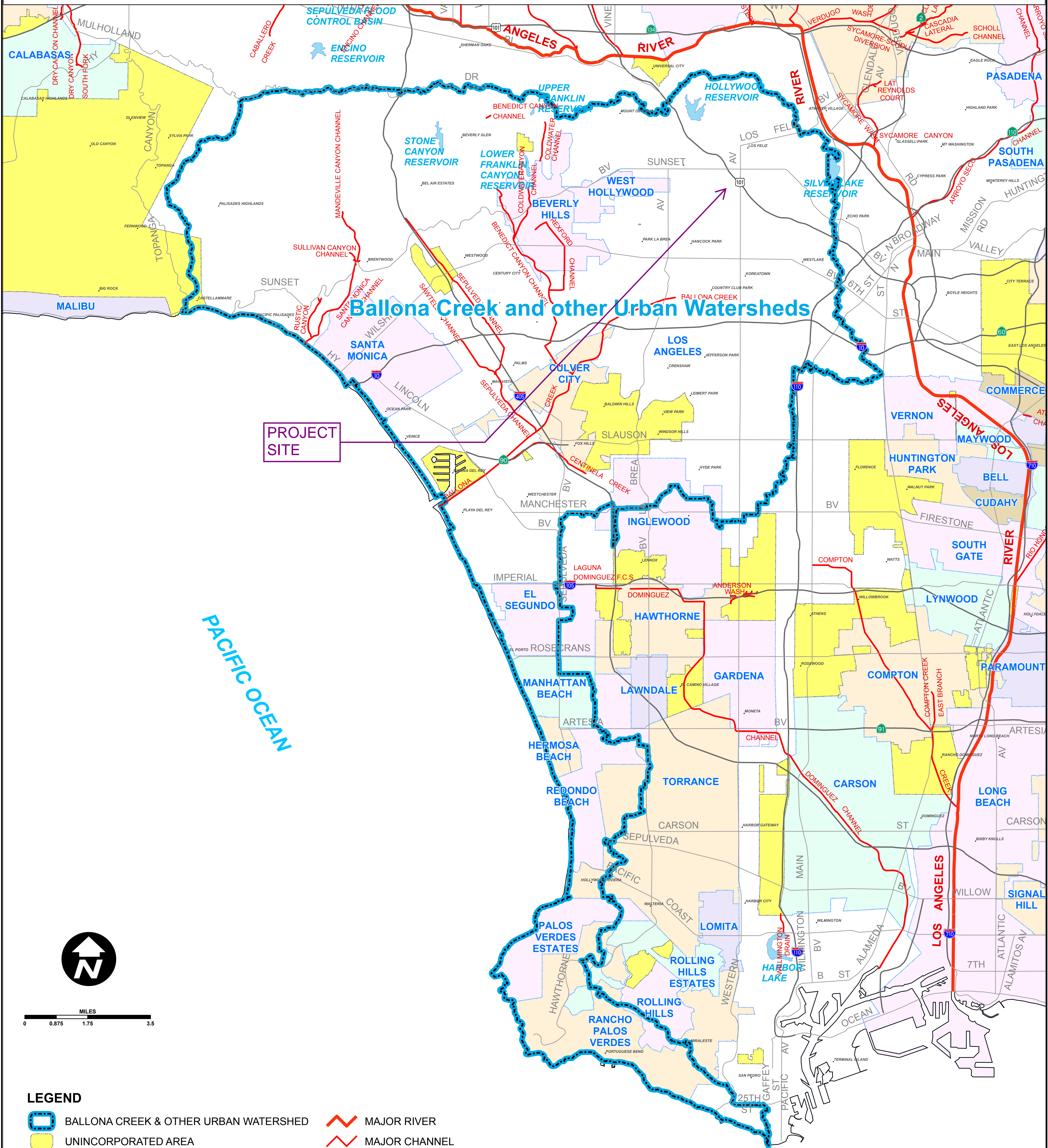

PROJECT SITE

PACIFIC OCEAN

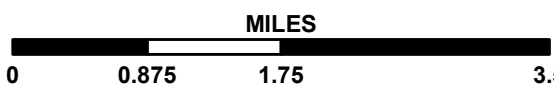

- LEGEND**
- BALLONA CREEK & OTHER URBAN WATERSHED
 - UNINCORPORATED AREA
 - DAM / LAKE / RESERVOIR
 - MAJOR RIVER
 - MAJOR CHANNEL

Data contained in this map is produced in whole or in part from the Los Angeles County Department of Public Works' digital database.

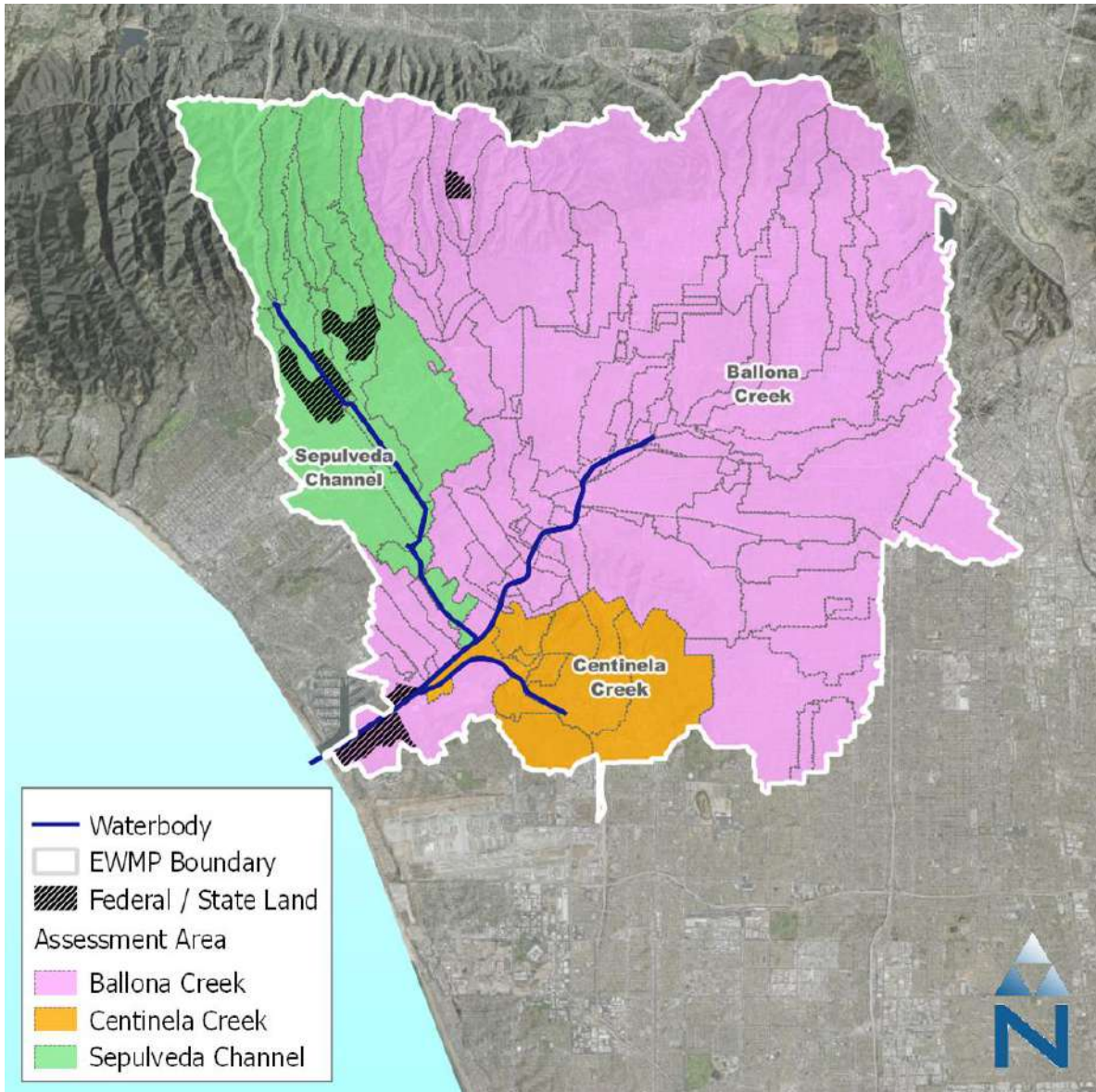

Figure 6-1 BCWMA and 180 Subwatersheds Represented by WMMS

6.1.2 SUSTAIN

SUSTAIN was developed by the USEPA to support practitioners in developing cost-effective management plans for municipal stormwater programs and evaluating and selecting BMPs to achieve water quality goals (USEPA, 2009; <http://www2.epa.gov/water-research/system-urban-stormwater-treatment-and-analysis-integration-sustain>). SUSTAIN was specifically developed as a decision-support system for selection and placement of BMPs at strategic locations in urban watersheds (see Figure 6-2). It includes a process-based continuous simulation BMP module for representing flow and pollutant transport routing through various types of structural BMPs. This simulation provides the *primary application* of SUSTAIN – simulating the performance of selected stormwater control measures.

ATTACHMENT B

LOCAL STORM DRAIN SYSTEM EXHIBIT

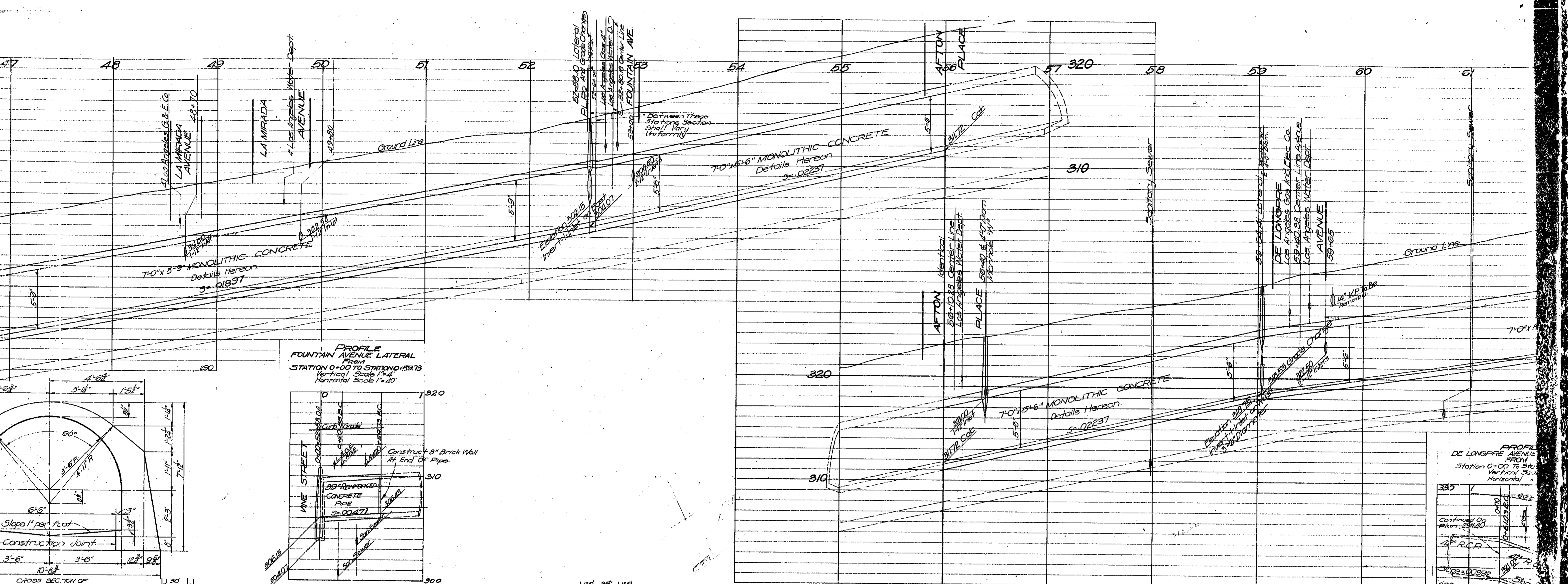

PROFILE
FOUNTAIN AVENUE LATERAL
 From
 STATION 0+00 TO STATION 0+52.73
 Vertical Scale 1"=4'
 Horizontal Scale 1"=20'

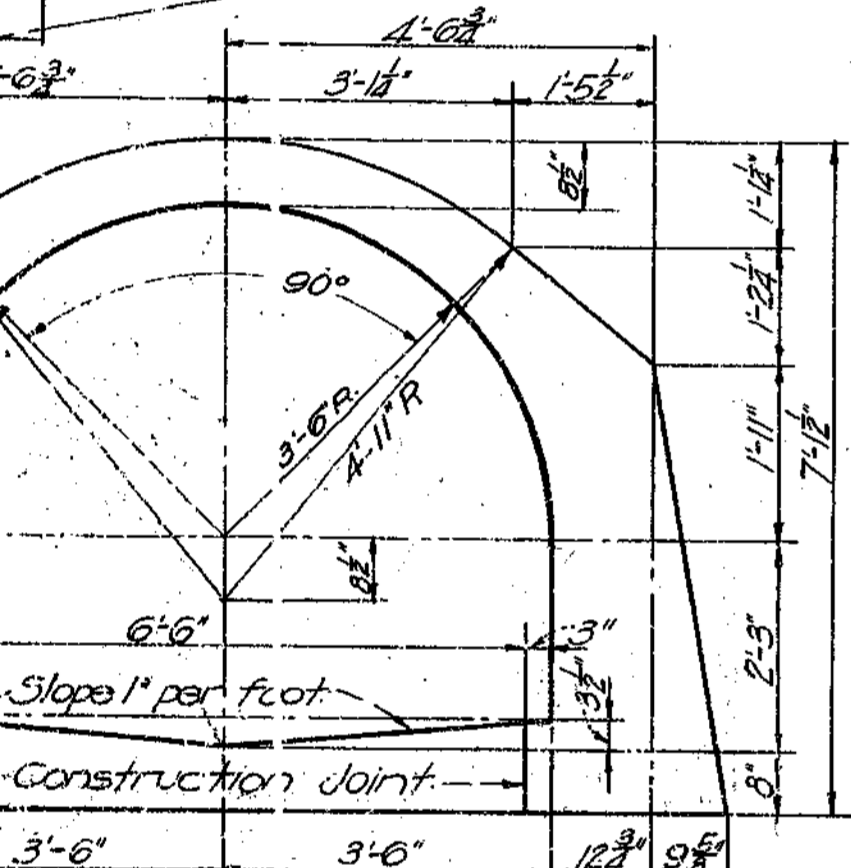
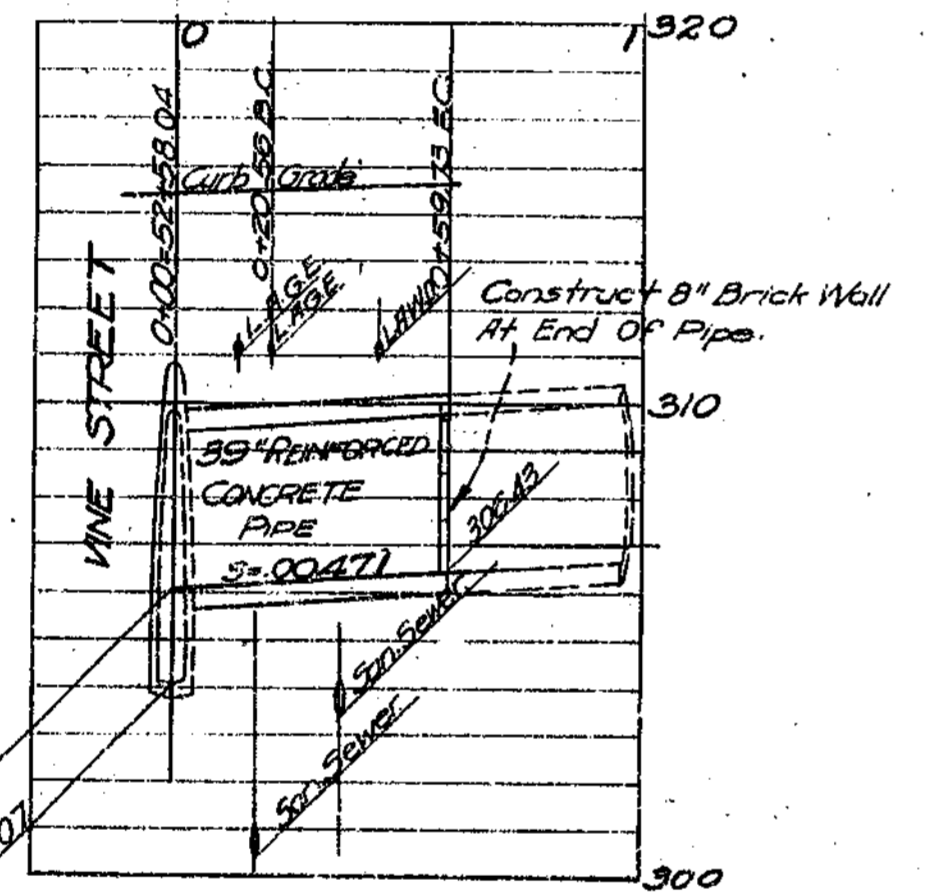

CROSS SECTION OF
**70\"/>
 70" WIDE BY 36" HIGH INSIDE
 FOR USE BETWEEN STATIONS
 52+64.74 AND 46+14.17**

PLAN
 Scale 1"=40'

PROFILE
DE LONGPRE AVENUE LATERAL
 FROM
 STATION 0+00 TO STATION 0+50
 Vertical Scale 1"=4'
 Horizontal Scale 1"=20'

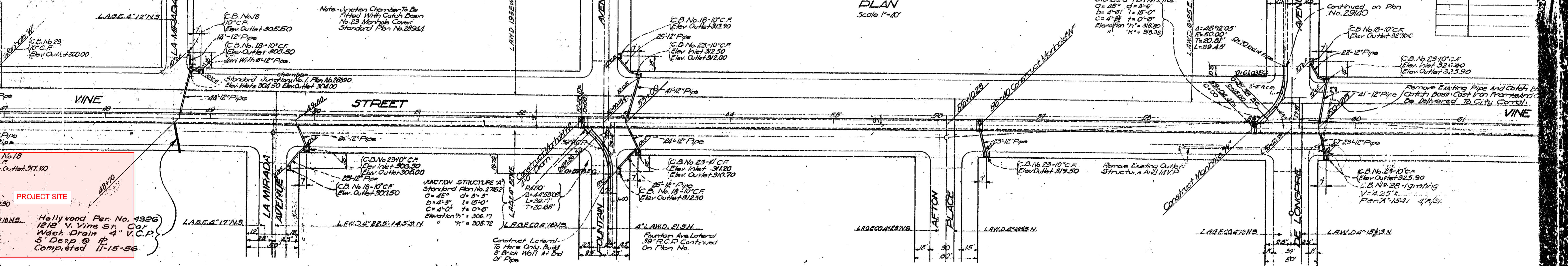
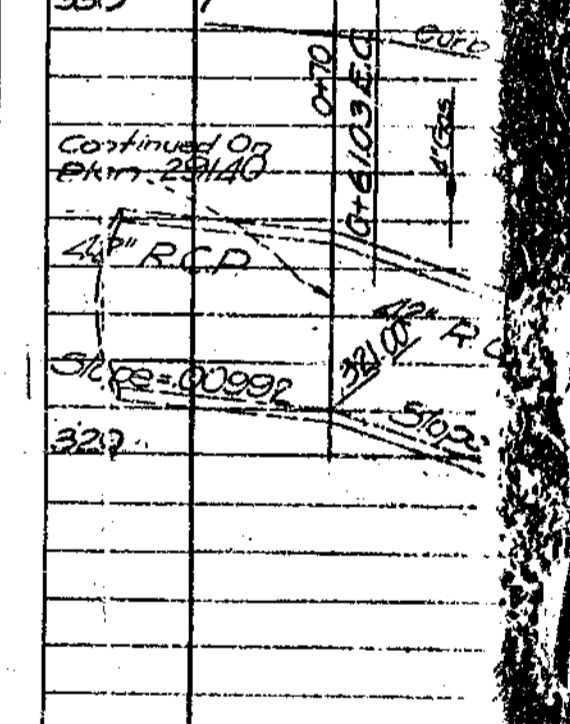

PROJECT SITE
 1218 N. Vine St. Car Wash Drain 4" V.C.P. 5' Deep @ 1% Completed 11-15-56

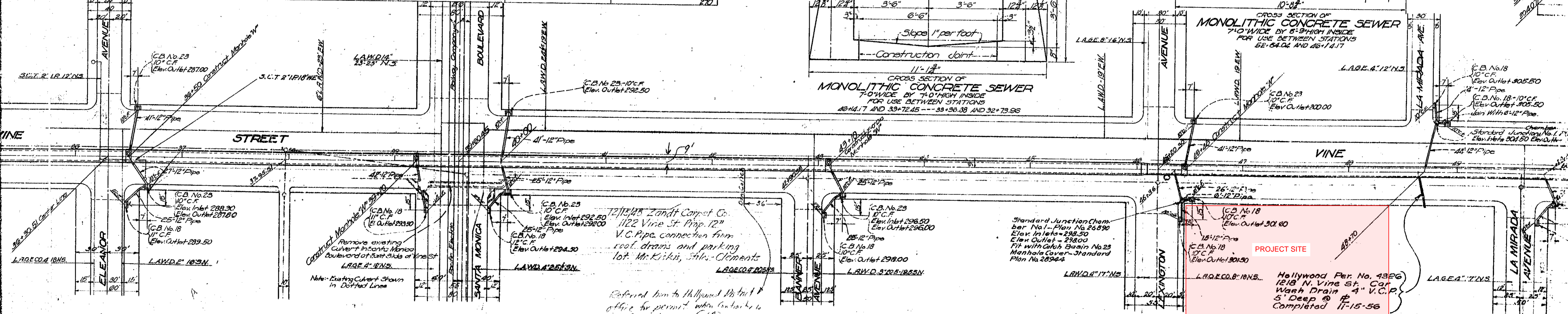
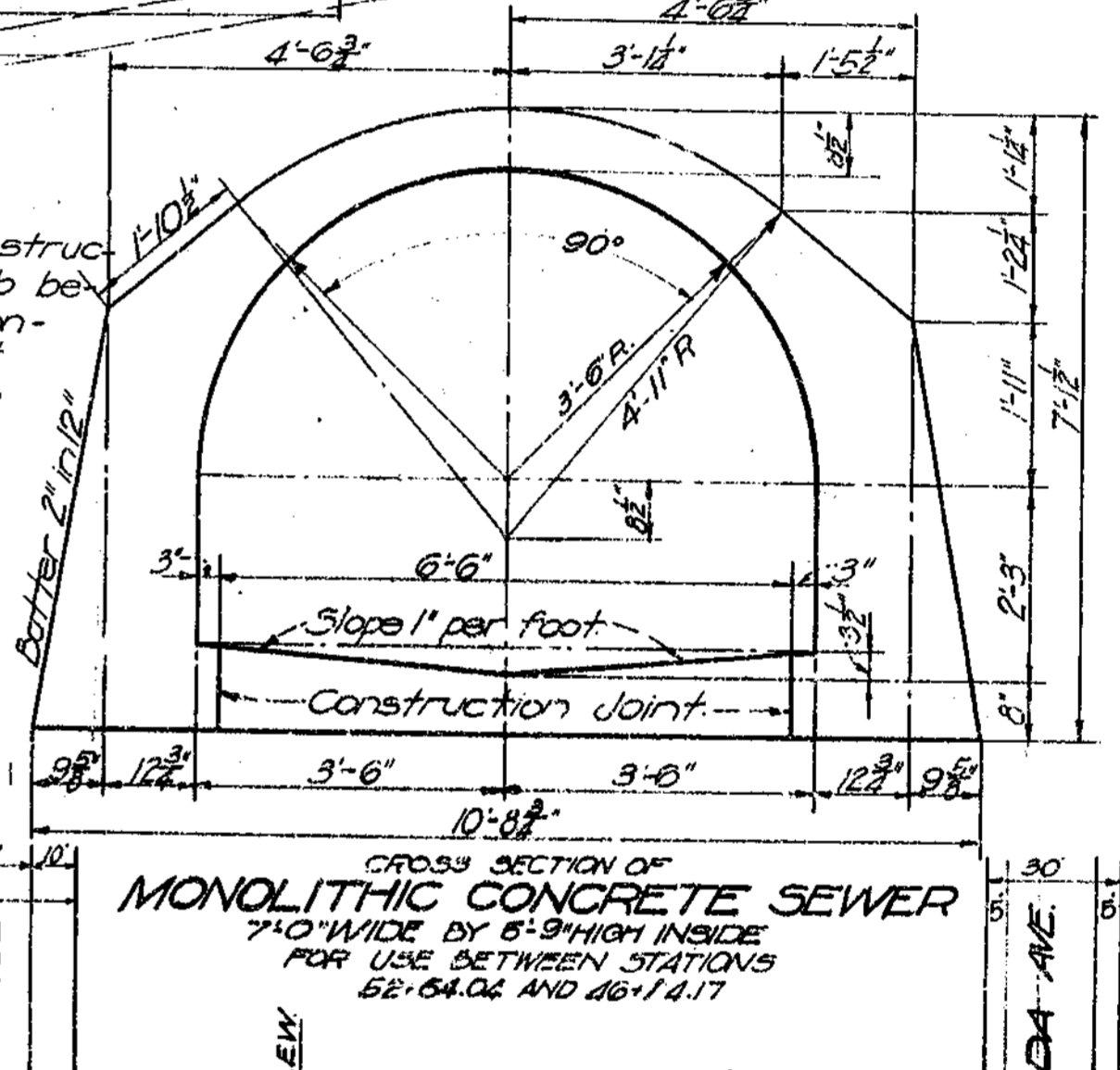
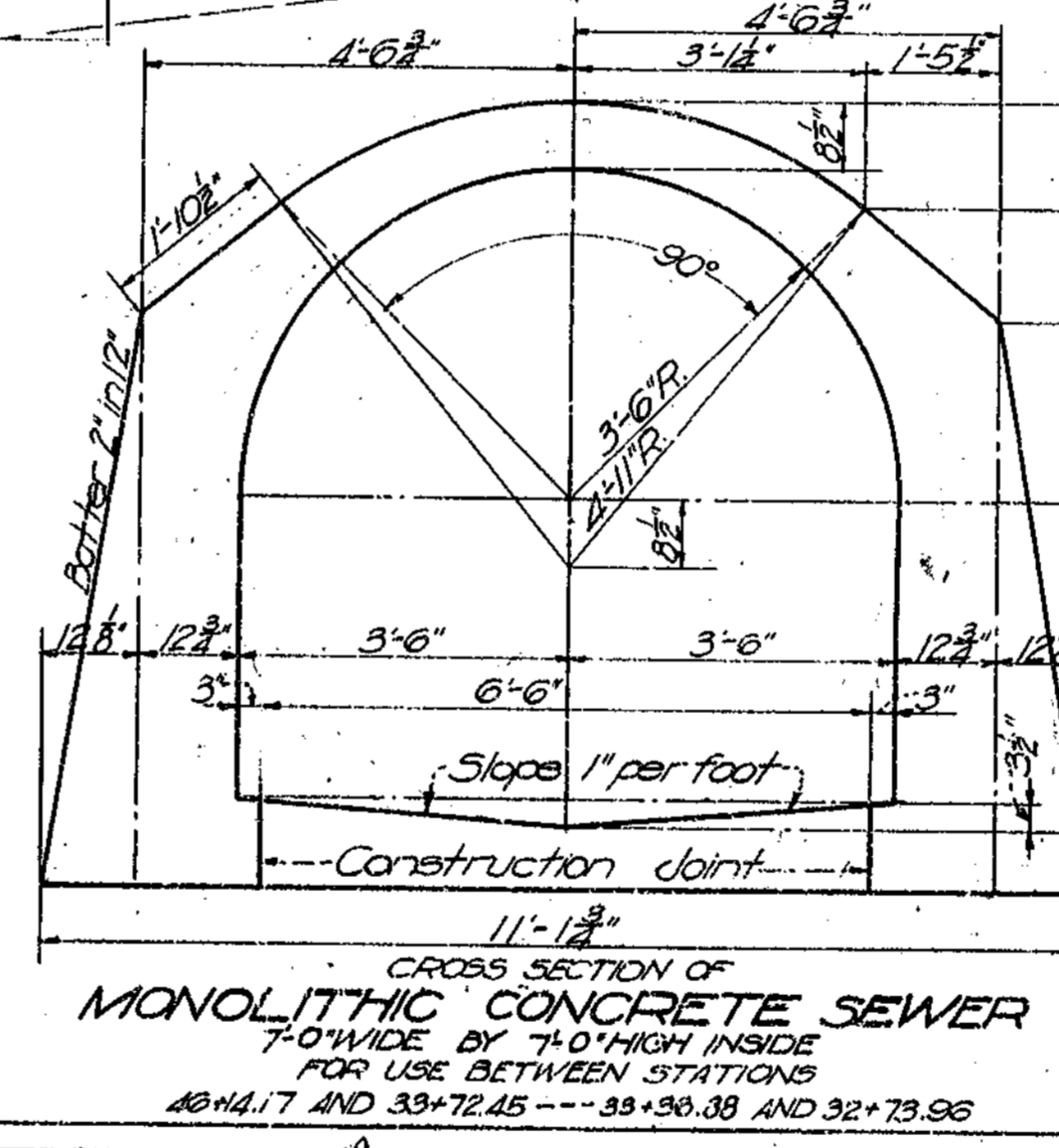
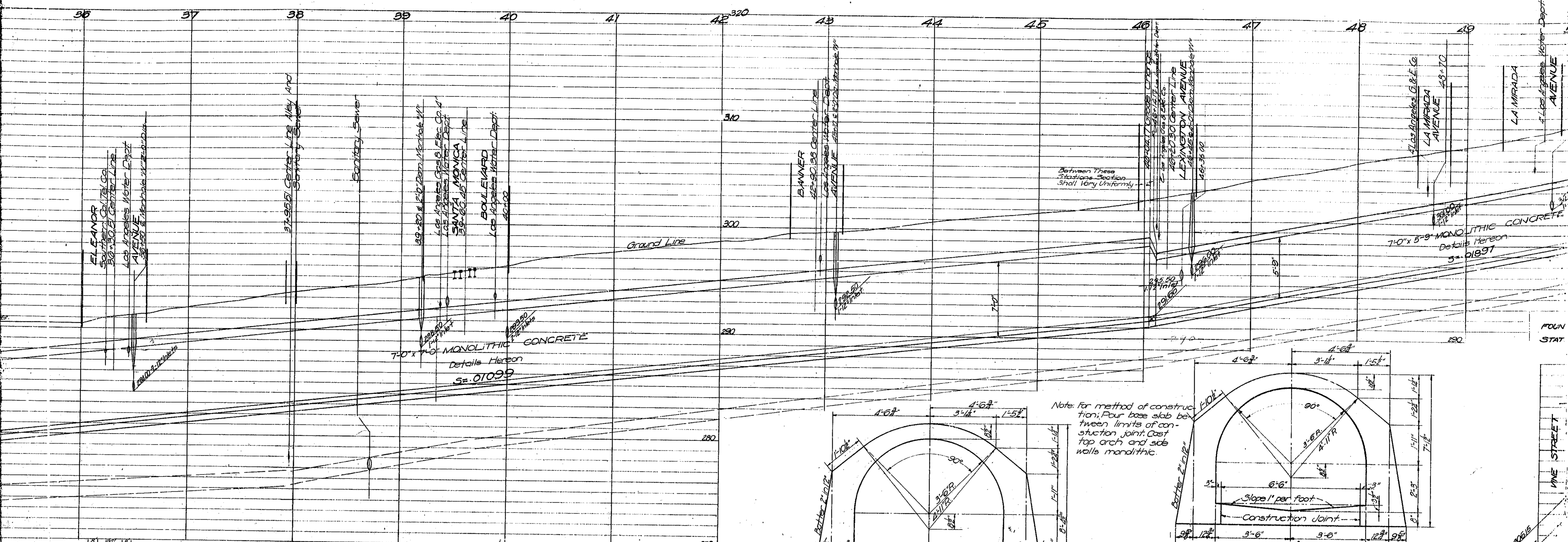





18475

18475

ATTACHMENT C

EXISTING ON-SITE HYDROLOGY

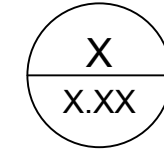
LEGEND & ABBREVIATIONS:

-  DRAINAGE AREA LIMIT
- AC ACRE
- CFS CUBIC FEET PER SECOND
- SF SQUARE FEET
- P/L PROPERTY LINE
- R/W RIGHT OF WAY
-  FLOW DIRECTION
-  SUB-AREA ID
ACREAGE
-  PERVIOUS AREA

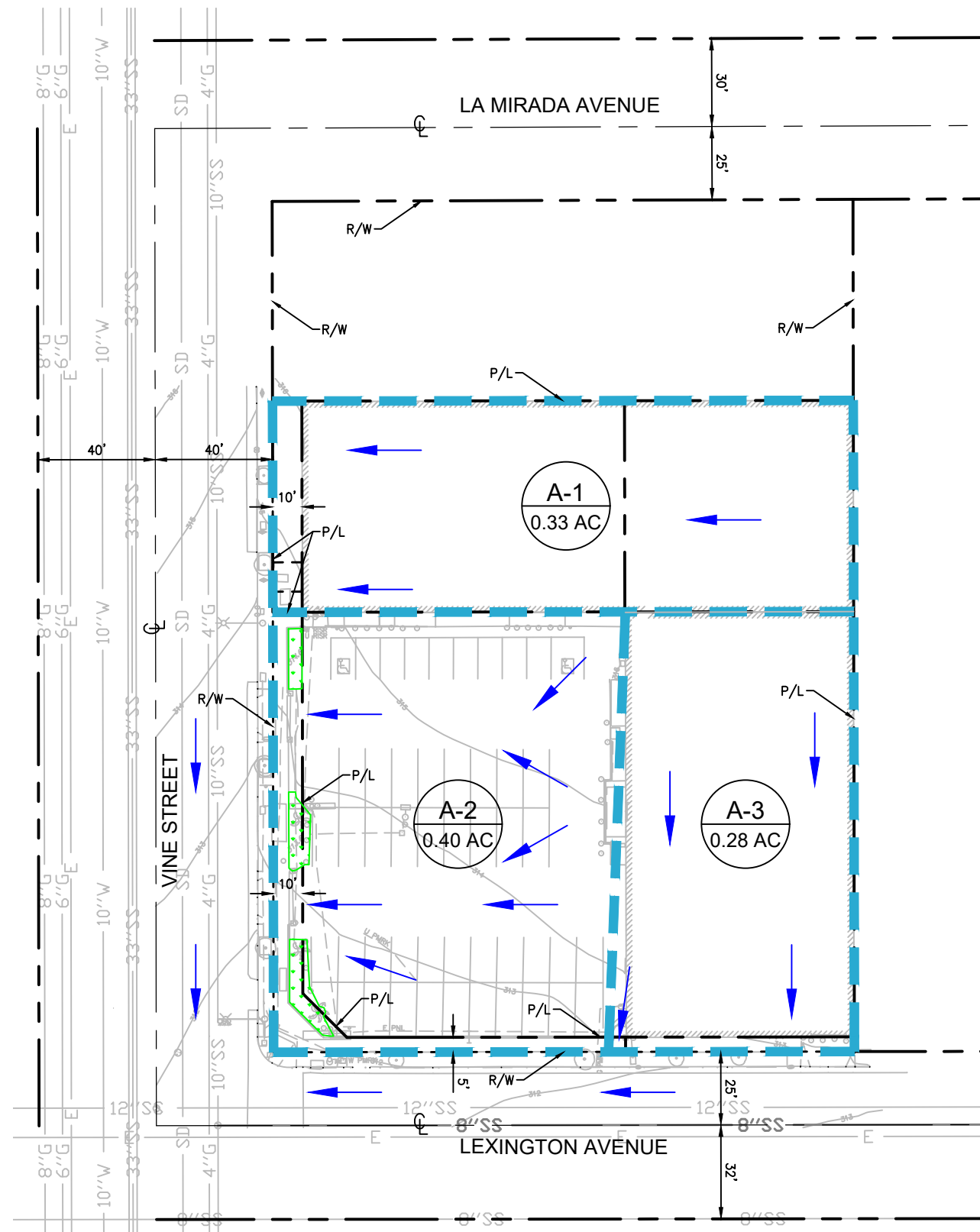

EXISTING HYDROLOGY MAP

1200 VINE STREET
LOS ANGELES, CA 90038

EXISTING HYDROLOGY CALCULATIONS							
SUBAREA ID	TOTAL AREA (SF/AC)	IMPERVIOUS AREA (SF/AC)	PERVIOUS AREA (SF/AC)	IMPERVIOUS %	Q10 (CFS)	Q25 (CFS)	Q50 (CFS)
A-1	14,256/0.33	14,256/0.33	0	100	0.68	0.91	1.04
A-2	17,575/0.40	17,098/0.39	477/0.01	97.3	0.89	1.10	1.25
A-3	12,125/0.28	12,125/0.28	0	100	0.63	0.77	0.88
TOTAL	43,956/1.01	43,479/1.00	477/0.01	99.1	2.20	2.78	3.17

NOTE:

SOIL TYPE - 6
50TH YR RAINFALL DEPTH - 5.85 IN
85TH PERCENTILE, RAINFALL DEPTH - 0.98 IN

CACLUATIONS BASED ON GROSS AREA

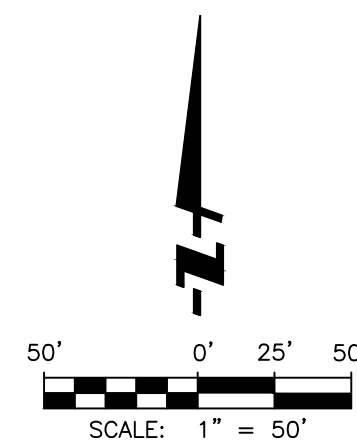

600 Wilshire Blvd., Suite 1470, Los Angeles, California 90017
tel 213.988.8802 • fax 213.988.8803 • www.fuscoe.com

ATTACHMENT D

HYDROCALC HYDROLOGY RESULTS FOR EXISTING SITE

Peak Flow Hydrologic Analysis

File location: F:/Projects/4103/001/_Support Files/Reports/Hydrology/Existing HydroCalc/1200 Vine - EX A-1 - 10yr.pdf
Version: HydroCalc 1.0.2

Input Parameters

Project Name	1200 Vine
Subarea ID	EX A-1
Area (ac)	0.33
Flow Path Length (ft)	210.62
Flow Path Slope (vft/hft)	0.005
50-yr Rainfall Depth (in)	5.85
Percent Impervious	1.0
Soil Type	6
Design Storm Frequency	10-yr
Fire Factor	0
LID	False

Output Results

Modeled (10-yr) Rainfall Depth (in)	4.1769
Peak Intensity (in/hr)	2.2874
Undeveloped Runoff Coefficient (Cu)	0.7638
Developed Runoff Coefficient (Cd)	0.9
Time of Concentration (min)	6.0
Clear Peak Flow Rate (cfs)	0.6794
Burned Peak Flow Rate (cfs)	0.6794
24-Hr Clear Runoff Volume (ac-ft)	0.1025
24-Hr Clear Runoff Volume (cu-ft)	4465.9435

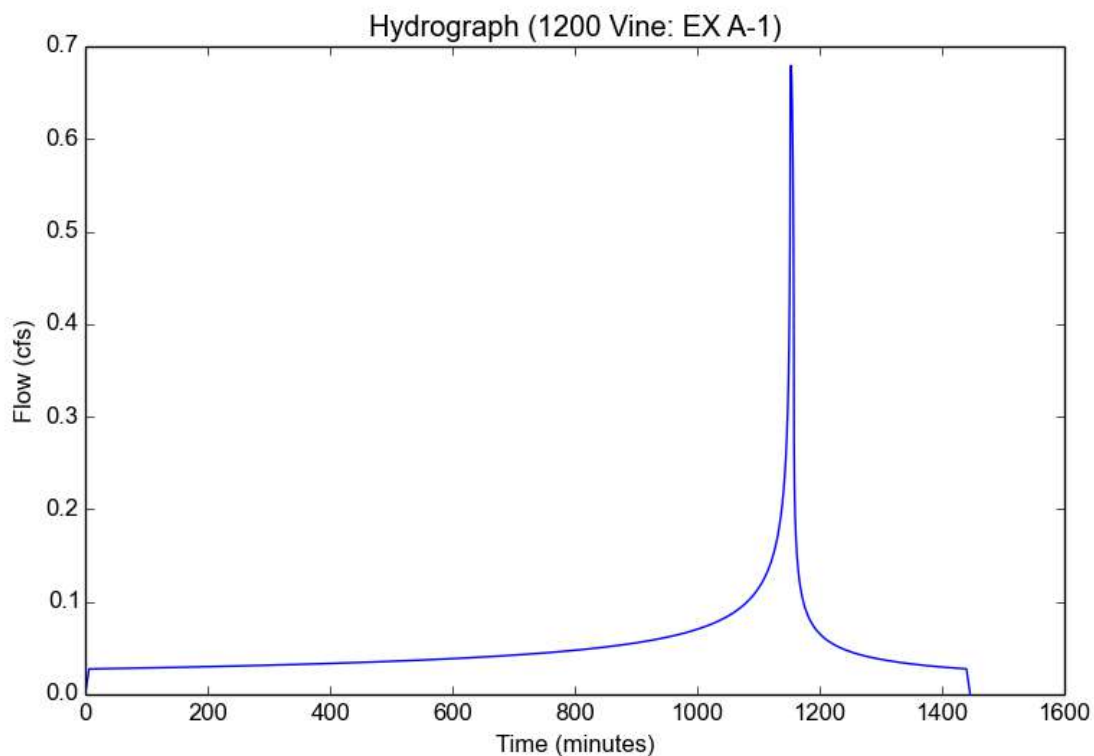

Peak Flow Hydrologic Analysis

File location: F:/Projects/4103/001/_Support Files/Reports/Hydrology/Existing HydroCalc/1200 Vine - EX A-1 - 25yr.pdf
Version: HydroCalc 1.0.2

Input Parameters

Project Name	1200 Vine
Subarea ID	EX A-1
Area (ac)	0.33
Flow Path Length (ft)	210.62
Flow Path Slope (vft/hft)	0.005
50-yr Rainfall Depth (in)	5.85
Percent Impervious	1.0
Soil Type	6
Design Storm Frequency	25-yr
Fire Factor	0
LID	False

Output Results

Modeled (25-yr) Rainfall Depth (in)	5.1363
Peak Intensity (in/hr)	3.0645
Undeveloped Runoff Coefficient (Cu)	0.8268
Developed Runoff Coefficient (Cd)	0.9
Time of Concentration (min)	5.0
Clear Peak Flow Rate (cfs)	0.9101
Burned Peak Flow Rate (cfs)	0.9101
24-Hr Clear Runoff Volume (ac-ft)	0.1261
24-Hr Clear Runoff Volume (cu-ft)	5491.7337

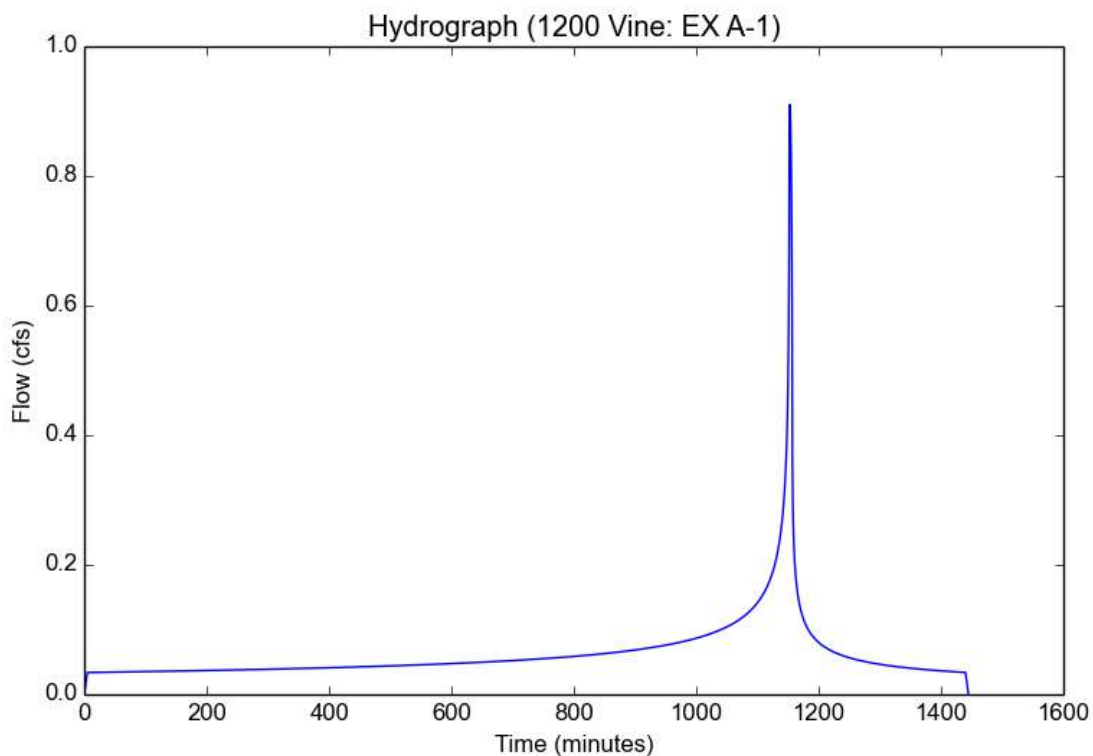

Peak Flow Hydrologic Analysis

File location: F:/Projects/4103/001/_Support Files/Reports/Hydrology/Existing HydroCalc/1200 Vine - EX A-1 - 50yr.pdf
Version: HydroCalc 1.0.2

Input Parameters

Project Name	1200 Vine
Subarea ID	EX A-1
Area (ac)	0.33
Flow Path Length (ft)	210.62
Flow Path Slope (vft/hft)	0.005
50-yr Rainfall Depth (in)	5.85
Percent Impervious	1.0
Soil Type	6
Design Storm Frequency	50-yr
Fire Factor	0
LID	False

Output Results

Modeled (50-yr) Rainfall Depth (in)	5.85
Peak Intensity (in/hr)	3.4903
Undeveloped Runoff Coefficient (Cu)	0.8567
Developed Runoff Coefficient (Cd)	0.9
Time of Concentration (min)	5.0
Clear Peak Flow Rate (cfs)	1.0366
Burned Peak Flow Rate (cfs)	1.0366
24-Hr Clear Runoff Volume (ac-ft)	0.1436
24-Hr Clear Runoff Volume (cu-ft)	6254.822

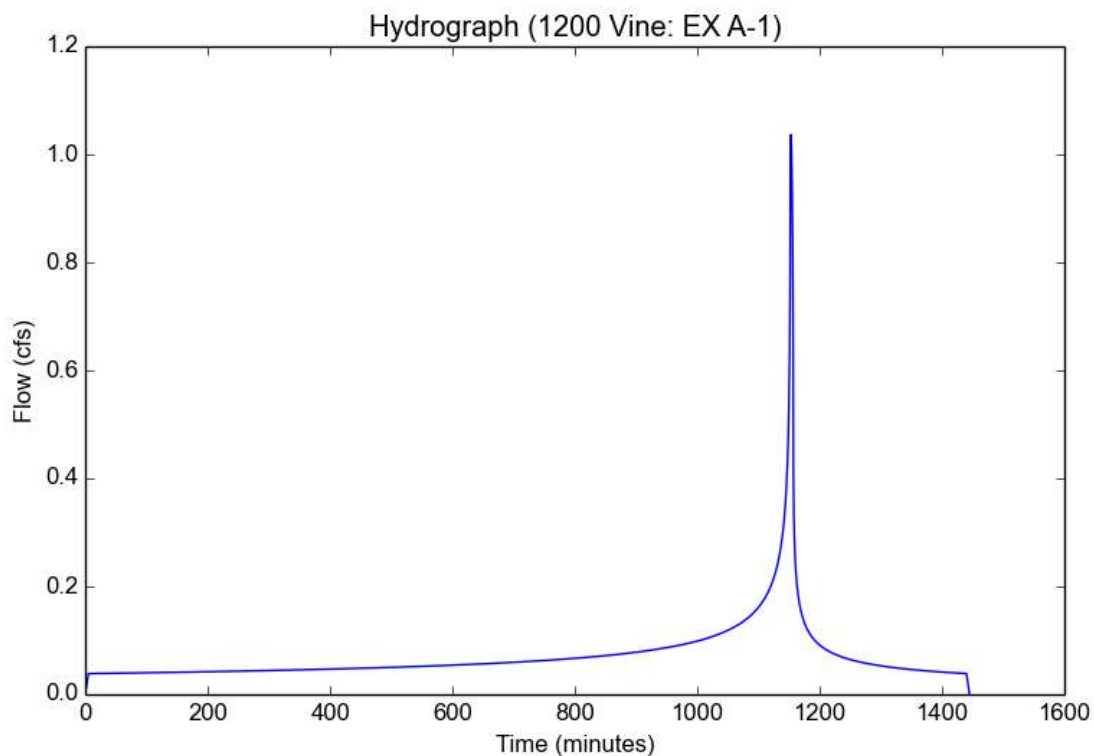

Peak Flow Hydrologic Analysis

File location: F:/Projects/4103/001/_Support Files/Reports/Hydrology/Existing HydroCalc/1200 Vine - EX A-2 - 10yr.pdf
Version: HydroCalc 1.0.2

Input Parameters

Project Name	1200 Vine
Subarea ID	EX A-2
Area (ac)	0.4
Flow Path Length (ft)	126.27
Flow Path Slope (vft/hft)	0.01
50-yr Rainfall Depth (in)	5.85
Percent Impervious	0.973
Soil Type	6
Design Storm Frequency	10-yr
Fire Factor	0
LID	False

Output Results

Modeled (10-yr) Rainfall Depth (in)	4.1769
Peak Intensity (in/hr)	2.4921
Undeveloped Runoff Coefficient (Cu)	0.7863
Developed Runoff Coefficient (Cd)	0.8969
Time of Concentration (min)	5.0
Clear Peak Flow Rate (cfs)	0.8941
Burned Peak Flow Rate (cfs)	0.8941
24-Hr Clear Runoff Volume (ac-ft)	0.1216
24-Hr Clear Runoff Volume (cu-ft)	5295.7735

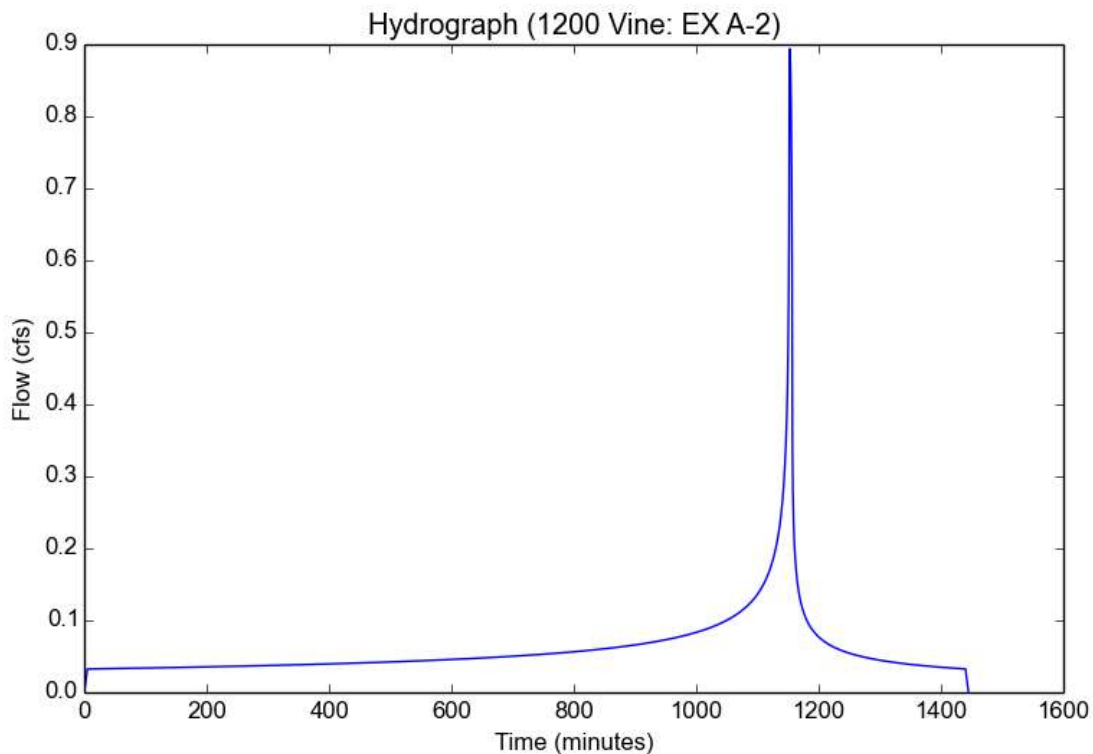

Peak Flow Hydrologic Analysis

File location: F:/Projects/4103/001/_Support Files/Reports/Hydrology/Existing HydroCalc/1200 Vine - EX A-2 - 25yr.pdf
Version: HydroCalc 1.0.2

Input Parameters

Project Name	1200 Vine
Subarea ID	EX A-2
Area (ac)	0.4
Flow Path Length (ft)	126.27
Flow Path Slope (vft/hft)	0.01
50-yr Rainfall Depth (in)	5.85
Percent Impervious	0.973
Soil Type	6
Design Storm Frequency	25-yr
Fire Factor	0
LID	False

Output Results

Modeled (25-yr) Rainfall Depth (in)	5.1363
Peak Intensity (in/hr)	3.0645
Undeveloped Runoff Coefficient (Cu)	0.8268
Developed Runoff Coefficient (Cd)	0.898
Time of Concentration (min)	5.0
Clear Peak Flow Rate (cfs)	1.1008
Burned Peak Flow Rate (cfs)	1.1008
24-Hr Clear Runoff Volume (ac-ft)	0.1496
24-Hr Clear Runoff Volume (cu-ft)	6516.3303

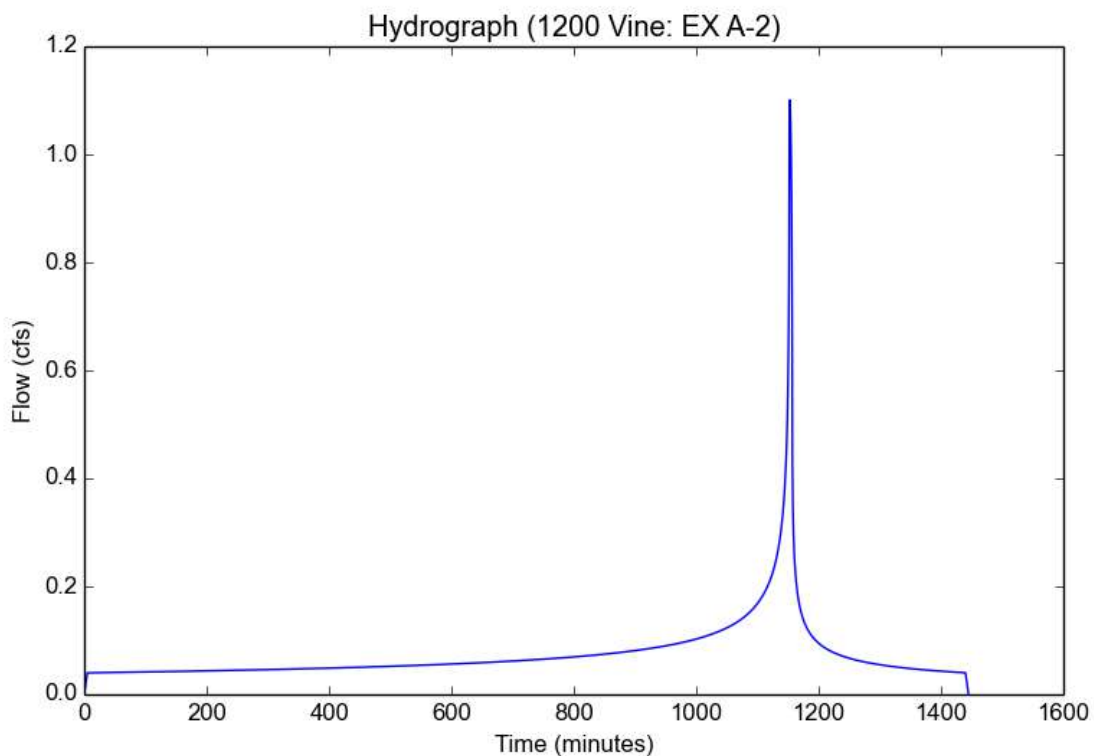

Peak Flow Hydrologic Analysis

File location: F:/Projects/4103/001/_Support Files/Reports/Hydrology/Existing HydroCalc/1200 Vine - EX A-2 - 50yr.pdf
Version: HydroCalc 1.0.2

Input Parameters

Project Name	1200 Vine
Subarea ID	EX A-2
Area (ac)	0.4
Flow Path Length (ft)	126.27
Flow Path Slope (vft/hft)	0.01
50-yr Rainfall Depth (in)	5.85
Percent Impervious	0.973
Soil Type	6
Design Storm Frequency	50-yr
Fire Factor	0
LID	False

Output Results

Modeled (50-yr) Rainfall Depth (in)	5.85
Peak Intensity (in/hr)	3.4903
Undeveloped Runoff Coefficient (Cu)	0.8567
Developed Runoff Coefficient (Cd)	0.8988
Time of Concentration (min)	5.0
Clear Peak Flow Rate (cfs)	1.2549
Burned Peak Flow Rate (cfs)	1.2549
24-Hr Clear Runoff Volume (ac-ft)	0.1705
24-Hr Clear Runoff Volume (cu-ft)	7425.4079

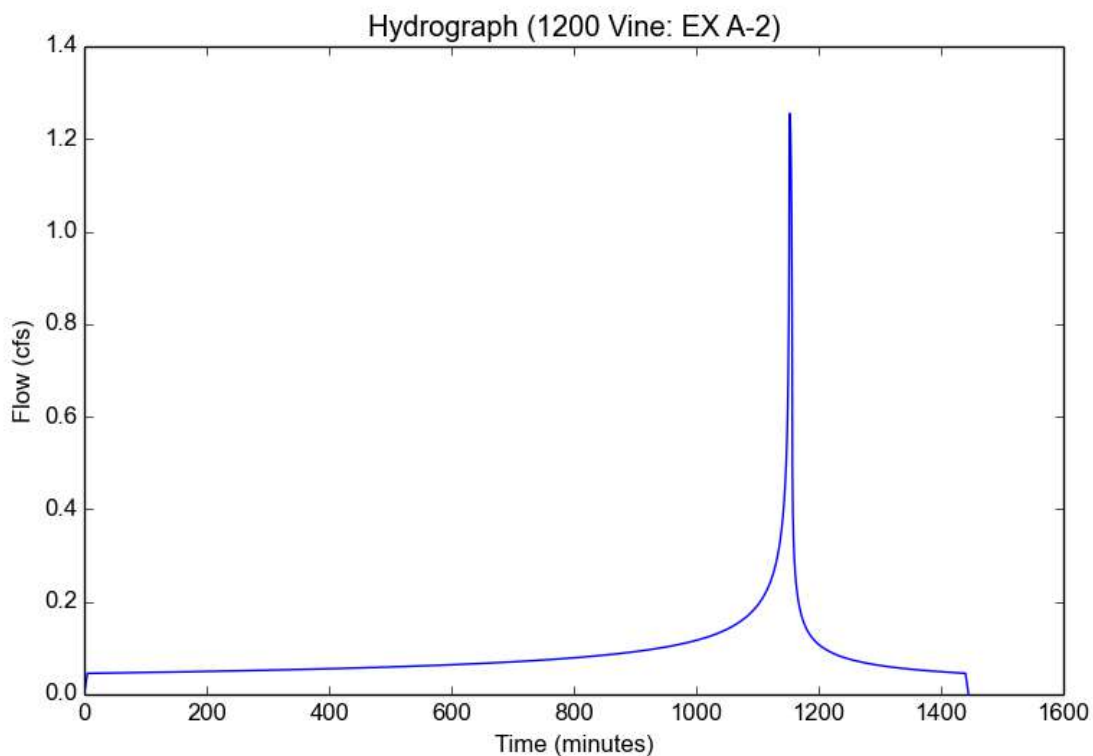

Peak Flow Hydrologic Analysis

File location: F:/Projects/4103/001/_Support Files/Reports/Hydrology/Existing HydroCalc/1200 Vine - EX A-3 - 10yr.pdf
Version: HydroCalc 1.0.2

Input Parameters

Project Name	1200 Vine
Subarea ID	EX A-3
Area (ac)	0.28
Flow Path Length (ft)	163.41
Flow Path Slope (vft/hft)	0.005
50-yr Rainfall Depth (in)	5.85
Percent Impervious	1.0
Soil Type	6
Design Storm Frequency	10-yr
Fire Factor	0
LID	False

Output Results

Modeled (10-yr) Rainfall Depth (in)	4.1769
Peak Intensity (in/hr)	2.4921
Undeveloped Runoff Coefficient (Cu)	0.7863
Developed Runoff Coefficient (Cd)	0.9
Time of Concentration (min)	5.0
Clear Peak Flow Rate (cfs)	0.628
Burned Peak Flow Rate (cfs)	0.628
24-Hr Clear Runoff Volume (ac-ft)	0.087
24-Hr Clear Runoff Volume (cu-ft)	3789.2849

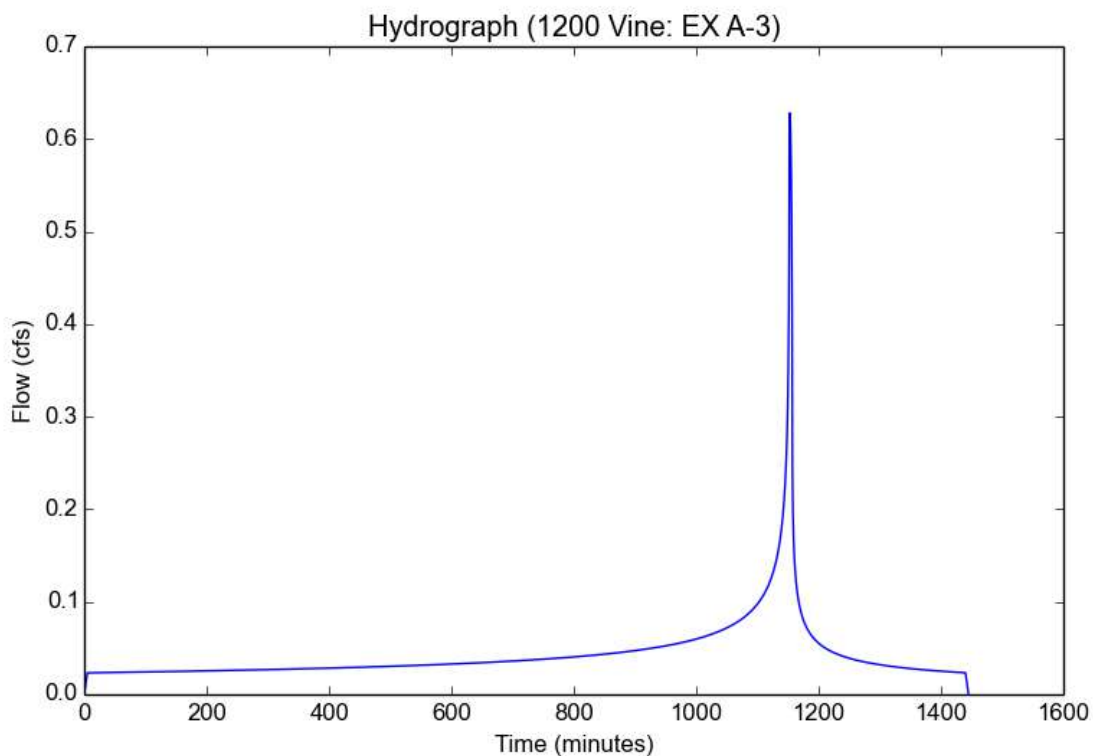

Peak Flow Hydrologic Analysis

File location: F:/Projects/4103/001/_Support Files/Reports/Hydrology/Existing HydroCalc/1200 Vine - EX A-3 - 25yr.pdf
Version: HydroCalc 1.0.2

Input Parameters

Project Name	1200 Vine
Subarea ID	EX A-3
Area (ac)	0.28
Flow Path Length (ft)	163.41
Flow Path Slope (vft/hft)	0.005
50-yr Rainfall Depth (in)	5.85
Percent Impervious	1.0
Soil Type	6
Design Storm Frequency	25-yr
Fire Factor	0
LID	False

Output Results

Modeled (25-yr) Rainfall Depth (in)	5.1363
Peak Intensity (in/hr)	3.0645
Undeveloped Runoff Coefficient (Cu)	0.8268
Developed Runoff Coefficient (Cd)	0.9
Time of Concentration (min)	5.0
Clear Peak Flow Rate (cfs)	0.7722
Burned Peak Flow Rate (cfs)	0.7722
24-Hr Clear Runoff Volume (ac-ft)	0.107
24-Hr Clear Runoff Volume (cu-ft)	4659.6528

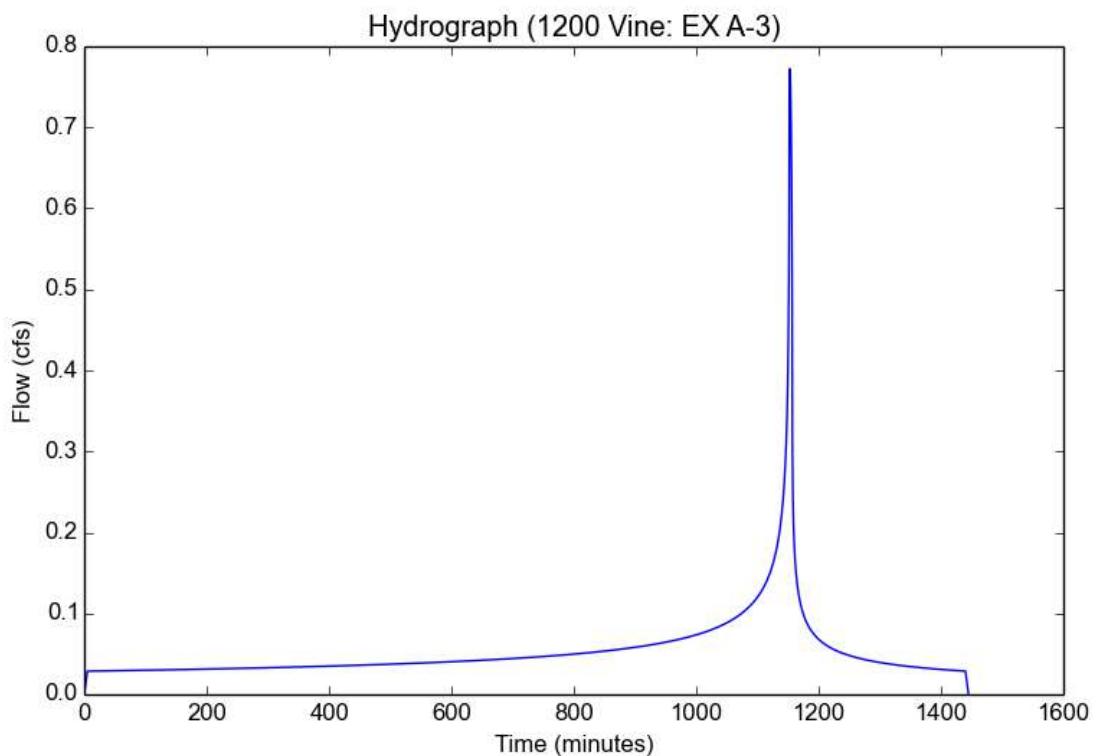

Peak Flow Hydrologic Analysis

File location: F:/Projects/4103/001/_Support Files/Reports/Hydrology/Existing HydroCalc/1200 Vine - EX A-3 - 50yr.pdf
Version: HydroCalc 1.0.2

Input Parameters

Project Name	1200 Vine
Subarea ID	EX A-3
Area (ac)	0.28
Flow Path Length (ft)	163.41
Flow Path Slope (vft/hft)	0.005
50-yr Rainfall Depth (in)	5.85
Percent Impervious	1.0
Soil Type	6
Design Storm Frequency	50-yr
Fire Factor	0
LID	False

Output Results

Modeled (50-yr) Rainfall Depth (in)	5.85
Peak Intensity (in/hr)	3.4903
Undeveloped Runoff Coefficient (Cu)	0.8567
Developed Runoff Coefficient (Cd)	0.9
Time of Concentration (min)	5.0
Clear Peak Flow Rate (cfs)	0.8795
Burned Peak Flow Rate (cfs)	0.8795
24-Hr Clear Runoff Volume (ac-ft)	0.1218
24-Hr Clear Runoff Volume (cu-ft)	5307.1217

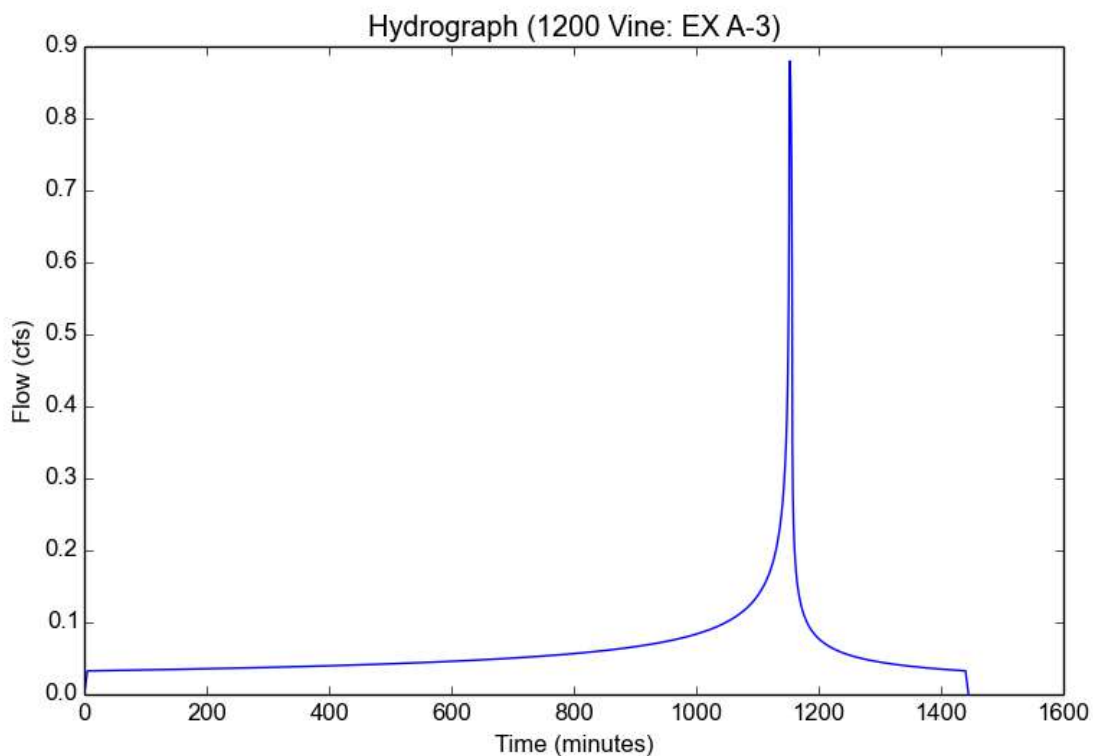

ATTACHMENT E

FEMA FLOODPLAIN MAP

National Flood Hazard Layer FIRMette



118°19'53"W 34°5'49"N



Legend

SEE FIS REPORT FOR DETAILED LEGEND AND INDEX MAP FOR FIRM PANEL LAYOUT

SPECIAL FLOOD HAZARD AREAS	Without Base Flood Elevation (BFE) Zone A, V, A99	With BFE or Depth Zone AE, AO, AH, VE, AR
	Regulatory Floodway	

OTHER AREAS OF FLOOD HAZARD	0.2% Annual Chance Flood Hazard, Areas of 1% annual chance flood with average depth less than one foot or with drainage areas of less than one square mile Zone X
	Future Conditions 1% Annual Chance Flood Hazard Zone X
	Area with Reduced Flood Risk due to Levee. See Notes. Zone X
	Area with Flood Risk due to Levee Zone D

OTHER AREAS	NO SCREEN Area of Minimal Flood Hazard Zone X
	Effective LOMRs
	Area of Undetermined Flood Hazard Zone D

GENERAL STRUCTURES	Channel, Culvert, or Storm Sewer
	Levee, Dike, or Floodwall

OTHER FEATURES	Cross Sections with 1% Annual Chance Water Surface Elevation
	20.2
	17.5
	Coastal Transect
	Base Flood Elevation Line (BFE)
	Limit of Study
	Jurisdiction Boundary
	Coastal Transect Baseline
	Profile Baseline
	Hydrographic Feature

MAP PANELS	Digital Data Available
	No Digital Data Available
	Unmapped



The pin displayed on the map is an approximate point selected by the user and does not represent an authoritative property location.

This map complies with FEMA's standards for the use of digital flood maps if it is not void as described below. The basemap shown complies with FEMA's basemap accuracy standards

The flood hazard information is derived directly from the authoritative NFHL web services provided by FEMA. This map was exported on **8/15/2022 at 3:04 PM** and does not reflect changes or amendments subsequent to this date and time. The NFHL and effective information may change or become superseded by new data over time.

This map image is void if the one or more of the following map elements do not appear: basemap imagery, flood zone labels, legend, scale bar, map creation date, community identifiers, FIRM panel number, and FIRM effective date. Map images for unmapped and unmodernized areas cannot be used for regulatory purposes.

ATTACHMENT F

2020 CALIFORNIA 303(D) LIST

CATEGORY 5
2020 CALIFORNIA 303(d) LIST OF WATER QUALITY LIMITED SEGMENTS*

Category 5 criteria: 1) A water segment where standards are not met and a TMDL is required, but not yet completed, for at least one of the pollutants being listed for this segment.

* USGS HUC = US Geological Survey Hydrologic Unit Code. Calwater = State Water Resources Control Board hydrological subunit area or even smaller planning watershed.

** TMDL requirement status definitions for listed pollutants are: A= TMDL still required, B= being addressed by USEPA approved TMDL, C= being addressed by action other than a TMDL, ALT= being addressed by USEPA approved TMDL alternative

*** Dates relate to the TMDL requirement status, so a date for A= TMDL scheduled completion date, B= Date USEPA approved TMDL, and C= Completion date for action other than a TMDL

REGION	WATER BODY NAME	WATER TYPE	WATERSHED* CALWATER / USGS HUC	POLLUTANT POTENTIAL SOURCES <i>Relevant Notes</i>	ESTIMATED AREA ASSESSED	FIRST YEAR LISTED	TMDL REQUIREMENT STATUS**	DATE***
Region 1	Big River Beach at Mendocino Bay	Coastal & Bay Shoreline	1113.300405 / 18010108	➤ <u>Indicator Bacteria</u> ➤ A Source Unknown	3.9 Miles	2010	5A	2022
Region 1	Bodega HU, Bodega Harbor HA	Bay & Harbor	11522000 / 18010111	➤ <u>Invasive Species</u> ➤ A Source Unknown	810 Acres	2006	5A	2025
Region 1	Bodega HU, Estero Americano HA, Americano Creek	River & Stream	1115.300001,1115.300002,1115.300003 / 18010111	➤ <u>Nutrients</u> ➤ A Source Unknown	38 Miles	1996	5A	2025
Region 1	Bodega HU, Estero Americano HA, estuary	Estuary	1115.300001,1115.300002 / 18010111	➤ <u>Nutrients</u> ➤ A Source Unknown	37 Acres	1996	5A	2025
				➤ <u>Sedimentation/Siltation</u> ➤ A Source Unknown	37 Acres	1992	5A	2025
Region 1	Bodega HU, Estero de San Antonio HA, Stemple Creek/Estero de San Antonio	River & Stream	1115.400001,1115.400002,1115.400003 / 18010111	➤ <u>Nutrients</u> ➤ A Source Unknown	87 Miles	2026	5A	2025
				➤ <u>Sediment</u> ➤ A Source Unknown	87 Miles	2006	5A	2025
Region 1	Campbell Cove	Coastal & Bay Shoreline	1115.210000,1115.220000 / 18010111	➤ <u>Indicator Bacteria</u> ➤ A Source Unknown	0.24 Miles	2006	5A	2022
Region 1	Caspar Headlands State Beach	Coastal & Bay Shoreline	1113.300404,1113.300405 / 18010108	➤ <u>Indicator Bacteria</u> ➤ A Source Unknown	0.19 Miles	2010	5A	2022
Region 1	Clam Beach (near Mad River mouth)	Coastal & Bay Shoreline	1109.100101 / 18010102	➤ <u>Indicator Bacteria</u> ➤ A Source Unknown	1.5 Miles	2012	5A	2022
Region 1	Clam Beach (near Strawberry Creek)	Coastal & Bay Shoreline	1108.200002,1109.100200,1109.100300 / 18010102	➤ <u>Indicator Bacteria</u> ➤ A Source Unknown	1.3 Miles	2006	5A	2022



REGION	WATER BODY NAME	WATER TYPE	WATERSHED* CALWATER / USGS HUC	POLLUTANT POTENTIAL SOURCES <i>Relevant Notes</i>	ESTIMATED AREA ASSESSED	FIRST YEAR LISTED	TMDL REQUIREMENT STATUS**	DATE***
Region 3	Zayante Creek	River & Stream	3304.120202,3304.120401,3304.120402 / 18060001	→ <u>Chlorpyrifos</u> → A Source Unknown	9.3 Miles	2010	5B	2015
				→ <u>Sedimentation/Siltation</u> → Channel Erosion → Habitat Modification → Other Urban Runoff → Removal of Riparian Vegetation → Road Construction	9.3 Miles	2002	5B	2004
				→ <u>Toxicity</u> → No Source Analysis Available	9.3 Miles	2014	5A	2035
Region 4	Alamitos Bay	Bay & Harbor	40512000 / 18070104	→ <u>Indicator Bacteria</u> → A Source Unknown	328 Acres	2006	5A	2019
				→ <u>Oxygen, Dissolved</u> → A Source Unknown	328 Acres	2014	5A	2027
Region 4	Alhambra Wash	River & Stream	40531000 / 18070105	→ <u>Ammonia</u> → Other	6.9 Miles	2014	5A	2027
Region 4	Artesia-Norwalk Drain	River & Stream	40515010 / 18070104	→ <u>Indicator Bacteria</u> → A Source Unknown	2.5 Miles	2010	5B	2016
				→ <u>Selenium</u> → A Source Unknown	2.5 Miles	2010	5A	2021
Region 4	Arundell Barranca (Ventura County)	River & Stream	40311000 / 18070103	→ <u>Indicator Bacteria</u> → A Source Unknown	4.9 Miles	2014	5A	2027
Region 4	Balboa Lake	Lake & Reservoir	4412.210000 / 18070105	→ <u>Ammonia</u> → A Source Unknown	28 Acres	2014	5B	2004
				→ <u>Oxygen, Dissolved</u> → A Source Unknown	28 Acres	2014	5A	2027
				→ <u>Toxicity</u> → A Source Unknown	28 Acres	2014	5A	2027
Region 4	Ballona Creek	River & Stream	40513000 / 18070104	→ <u>Copper</u> → A Source Unknown	6.5 Miles	1800	5B	2005
				→ <u>Cyanide</u> → A Source Unknown	6.5 Miles	1996	5A	2019
				→ <u>Indicator Bacteria</u> → Nonpoint Source → Point Source	6.5 Miles	2014	5B	2007
				→ <u>Lead</u> → A Source Unknown	6.5 Miles	2002	5B	2005

REGION	WATER BODY NAME	WATER TYPE	WATERSHED* CALWATER / USGS HUC	POLLUTANT POTENTIAL SOURCES <i>Relevant Notes</i>	ESTIMATED AREA ASSESSED	FIRST YEAR LISTED	TMDL REQUIREMENT STATUS**	DATE***
				<ul style="list-style-type: none"> <u>Toxicity</u> <ul style="list-style-type: none"> → A Source Unknown <p><i>The sediment toxicity collected to support this listing decision were collected from Reach 2 of Ballona Creek as identified in the Los Angeles Regional Basin Plan.</i></p> → <u>Trash</u> <ul style="list-style-type: none"> → A Source Unknown → <u>Viruses (enteric)</u> <ul style="list-style-type: none"> → Nonpoint Source → Point Source → <u>Zinc</u> <ul style="list-style-type: none"> → A Source Unknown 	6.5 Miles	1996	5B	2005
Region 4	Boulder Creek (Ventura County)	River & Stream	40331000 / 18070102	<ul style="list-style-type: none"> → <u>Bifenthrin</u> <ul style="list-style-type: none"> → A Source Unknown → <u>Toxicity</u> <ul style="list-style-type: none"> → A Source Unknown 	6.5 Miles	2014	5A	2027
Region 4	Bouquet Canyon Creek (below Bouquet Reservoir)	River & Stream	40352000 / 18070102	<ul style="list-style-type: none"> → <u>Temperature, water</u> <ul style="list-style-type: none"> → A Source Unknown 	14 Miles	2014	5A	2029
Region 4	Bull Creek (Los Angeles County)	River & Stream	40521000 / 18070105	<ul style="list-style-type: none"> → <u>Ammonia</u> <ul style="list-style-type: none"> → A Source Unknown → <u>Toxicity</u> <ul style="list-style-type: none"> → A Source Unknown 	6.5 Miles	2014	5B	2004
Region 4	Burbank Western Channel	River & Stream	40521000 / 18070105	<ul style="list-style-type: none"> → <u>Copper</u> <ul style="list-style-type: none"> → A Source Unknown → <u>Cyanide</u> <ul style="list-style-type: none"> → A Source Unknown → <u>Indicator Bacteria</u> <ul style="list-style-type: none"> → A Source Unknown → <u>Lead</u> <ul style="list-style-type: none"> → A Source Unknown → <u>Selenium</u> <ul style="list-style-type: none"> → A Source Unknown → <u>Trash</u> <ul style="list-style-type: none"> → Nonpoint Source → Surface Runoff → Urban Runoff/Storm Sewers 	13 Miles	2006	5B	2005
					13 Miles	2006	5A	2019
					13 Miles	2010	5B	2012
					13 Miles	2006	5B	2005
					13 Miles	2010	5A	2021
					13 Miles	1996	5B	2008

ATTACHMENT G

PROPOSED ON-SITE HYDROLOGY MAP

LEGEND & ABBREVIATIONS:

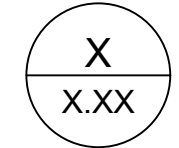
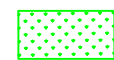
-  DRAINAGE AREA LIMIT
- AC ACRE
- CFS CUBIC FEET PER SECOND
- SF SQUARE FEET
- P/L PROPERTY LINE
- R/W RIGHT OF WAY
-  FLOW DIRECTION
-  SUB-AREA ID
ACREAGE
-  PERVIOUS AREA

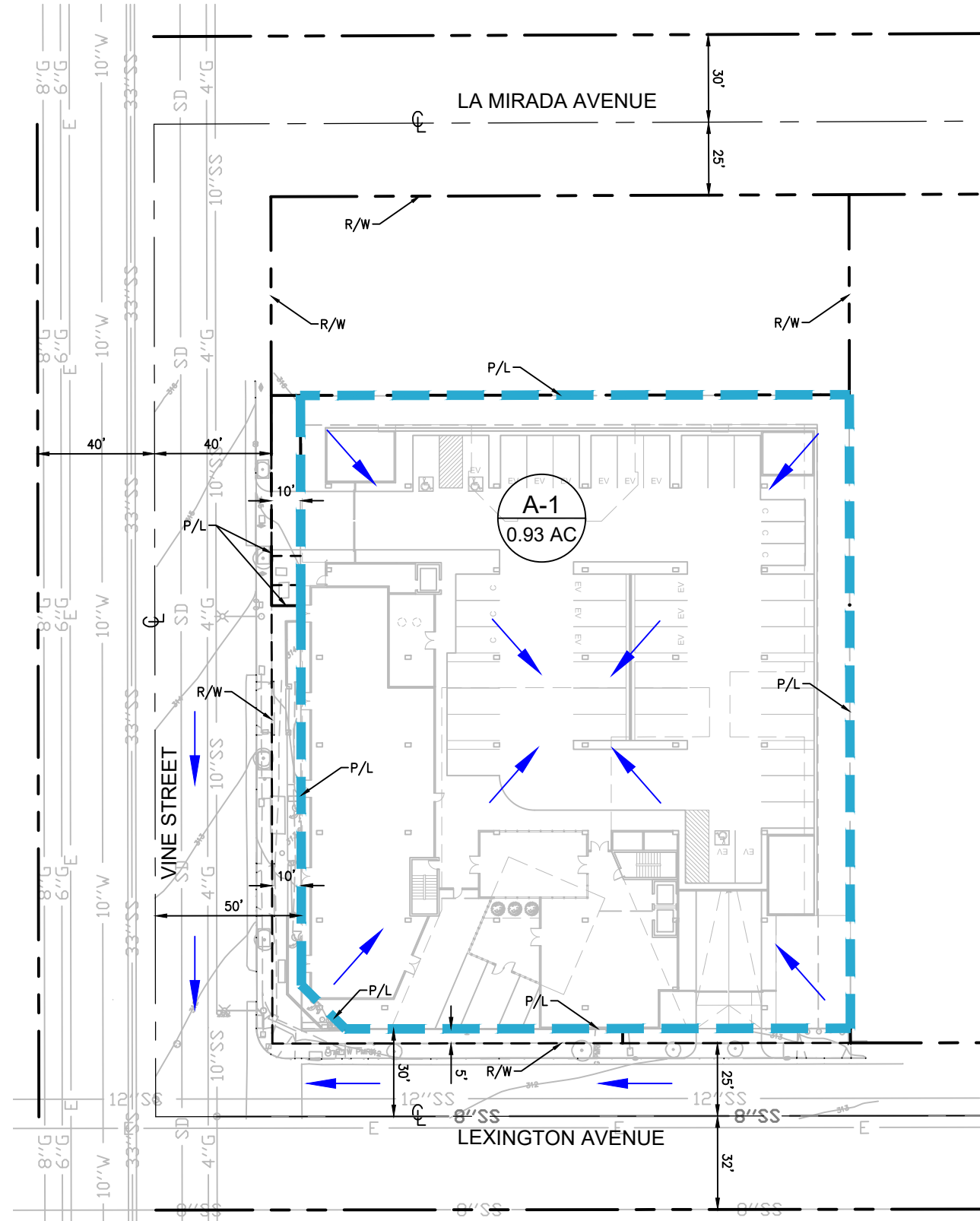

PROPOSED HYDROLOGY MAP

1200 VINE STREET
LOS ANGELES, CA 90038

PROPOSED HYDROLOGY CALCULATIONS							
SUBAREA ID	TOTAL AREA (SF/AC)	IMPERVIOUS AREA (SF/AC)	PERVIOUS AREA (SF/AC)	IMPERVIOUS %	Q10 (CFS)	Q25 (CFS)	Q50 (CFS)
A-1	40,683/0.93	34,722/0.80	5,961/0.13	85.3	2.05	2.53	2.90

NOTE:

SOIL TYPE - 6
50TH YR RAINFALL DEPTH - 5.85 IN
85TH PERCENTILE, RAINFALL DEPTH - 0.98 IN

CACLUATIONS BASED ON NET AREA
PROPOSED PERVIOUS AREAS ARE NOT SHOWN

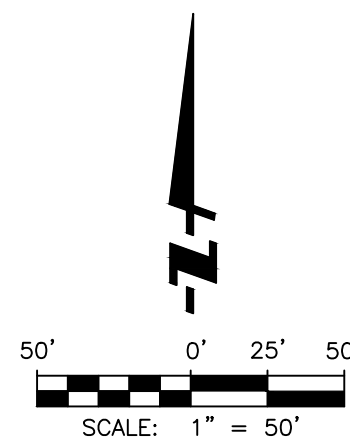

600 Wilshire Blvd., Suite 1470, Los Angeles, California 90017
tel 213.988.8802 • fax 213.988.8803 • www.fuscoe.com

ATTACHMENT H

HYDROCALC HYDROLOGY RESULTS FOR PROPOSED SITE

Peak Flow Hydrologic Analysis

File location: F:/Projects/4103/001/_Support Files/Reports/Hydrology/Proposed HydroCalc/1200 Vine - PR A-1 - 10yr.pdf
Version: HydroCalc 1.0.2

Input Parameters

Project Name	1200 Vine
Subarea ID	PR A-1
Area (ac)	0.93
Flow Path Length (ft)	144.0
Flow Path Slope (vft/hft)	0.02
50-yr Rainfall Depth (in)	5.85
Percent Impervious	0.853
Soil Type	6
Design Storm Frequency	10-yr
Fire Factor	0
LID	False

Output Results

Modeled (10-yr) Rainfall Depth (in)	4.1769
Peak Intensity (in/hr)	2.4921
Undeveloped Runoff Coefficient (Cu)	0.7863
Developed Runoff Coefficient (Cd)	0.8833
Time of Concentration (min)	5.0
Clear Peak Flow Rate (cfs)	2.0471
Burned Peak Flow Rate (cfs)	2.0471
24-Hr Clear Runoff Volume (ac-ft)	0.2548
24-Hr Clear Runoff Volume (cu-ft)	11098.6044

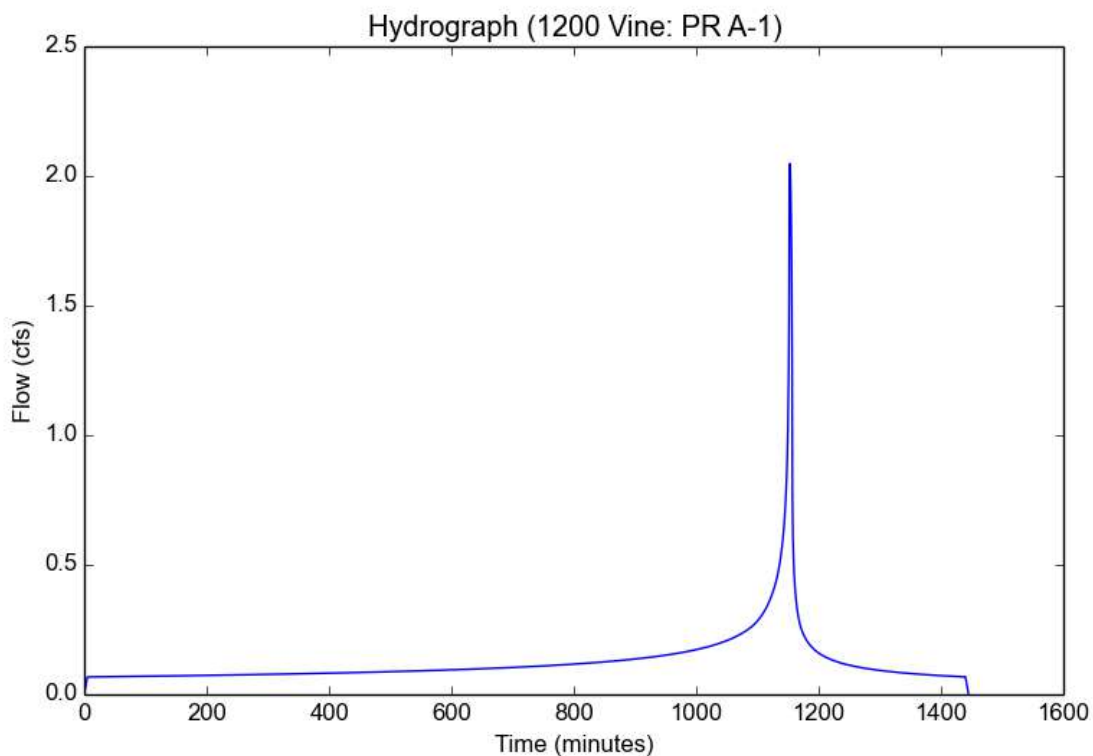

Peak Flow Hydrologic Analysis

File location: F:/Projects/4103/001/_Support Files/Reports/Hydrology/Proposed HydroCalc/1200 Vine - PR A-1 - 25yr.pdf
Version: HydroCalc 1.0.2

Input Parameters

Project Name	1200 Vine
Subarea ID	PR A-1
Area (ac)	0.93
Flow Path Length (ft)	144.0
Flow Path Slope (vft/hft)	0.02
50-yr Rainfall Depth (in)	5.85
Percent Impervious	0.853
Soil Type	6
Design Storm Frequency	25-yr
Fire Factor	0
LID	False

Output Results

Modeled (25-yr) Rainfall Depth (in)	5.1363
Peak Intensity (in/hr)	3.0645
Undeveloped Runoff Coefficient (Cu)	0.8268
Developed Runoff Coefficient (Cd)	0.8892
Time of Concentration (min)	5.0
Clear Peak Flow Rate (cfs)	2.5343
Burned Peak Flow Rate (cfs)	2.5343
24-Hr Clear Runoff Volume (ac-ft)	0.3145
24-Hr Clear Runoff Volume (cu-ft)	13700.5299

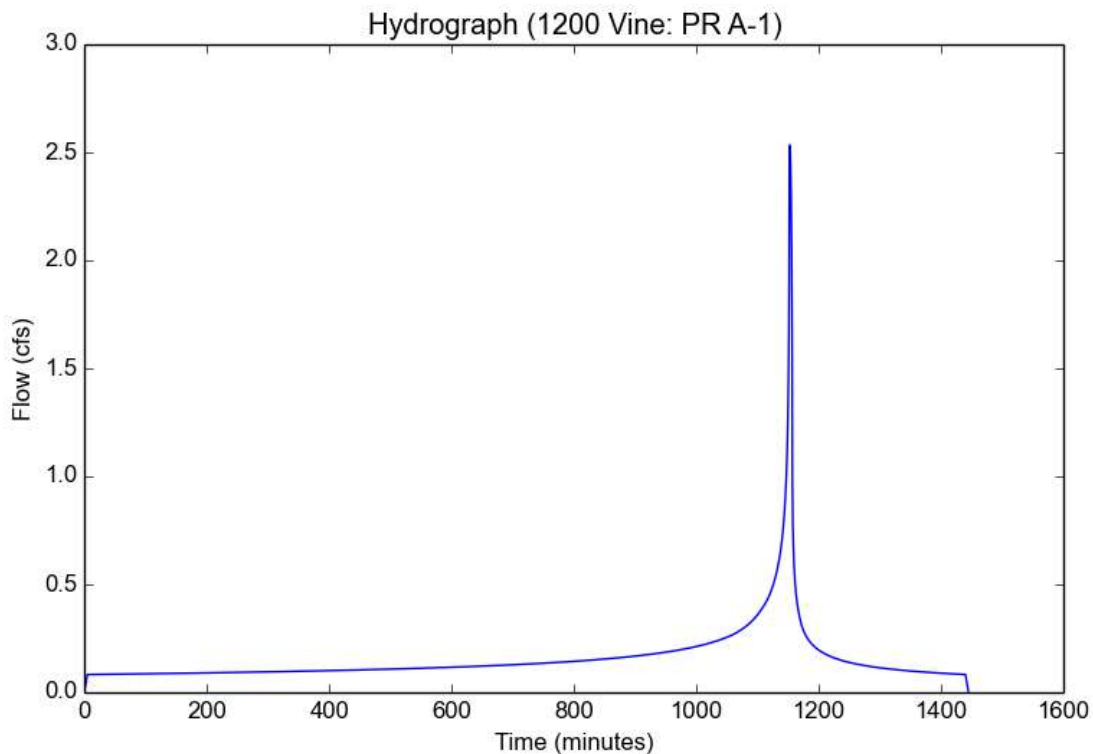

Peak Flow Hydrologic Analysis

File location: F:/Projects/4103/001/_Support Files/Reports/Hydrology/Proposed HydroCalc/1200 Vine - PR A-1 - 50yr.pdf
Version: HydroCalc 1.0.2

Input Parameters

Project Name	1200 Vine
Subarea ID	PR A-1
Area (ac)	0.93
Flow Path Length (ft)	144.0
Flow Path Slope (vft/hft)	0.02
50-yr Rainfall Depth (in)	5.85
Percent Impervious	0.853
Soil Type	6
Design Storm Frequency	50-yr
Fire Factor	0
LID	False

Output Results

Modeled (50-yr) Rainfall Depth (in)	5.85
Peak Intensity (in/hr)	3.4903
Undeveloped Runoff Coefficient (Cu)	0.8567
Developed Runoff Coefficient (Cd)	0.8936
Time of Concentration (min)	5.0
Clear Peak Flow Rate (cfs)	2.9007
Burned Peak Flow Rate (cfs)	2.9007
24-Hr Clear Runoff Volume (ac-ft)	0.3593
24-Hr Clear Runoff Volume (cu-ft)	15650.0641

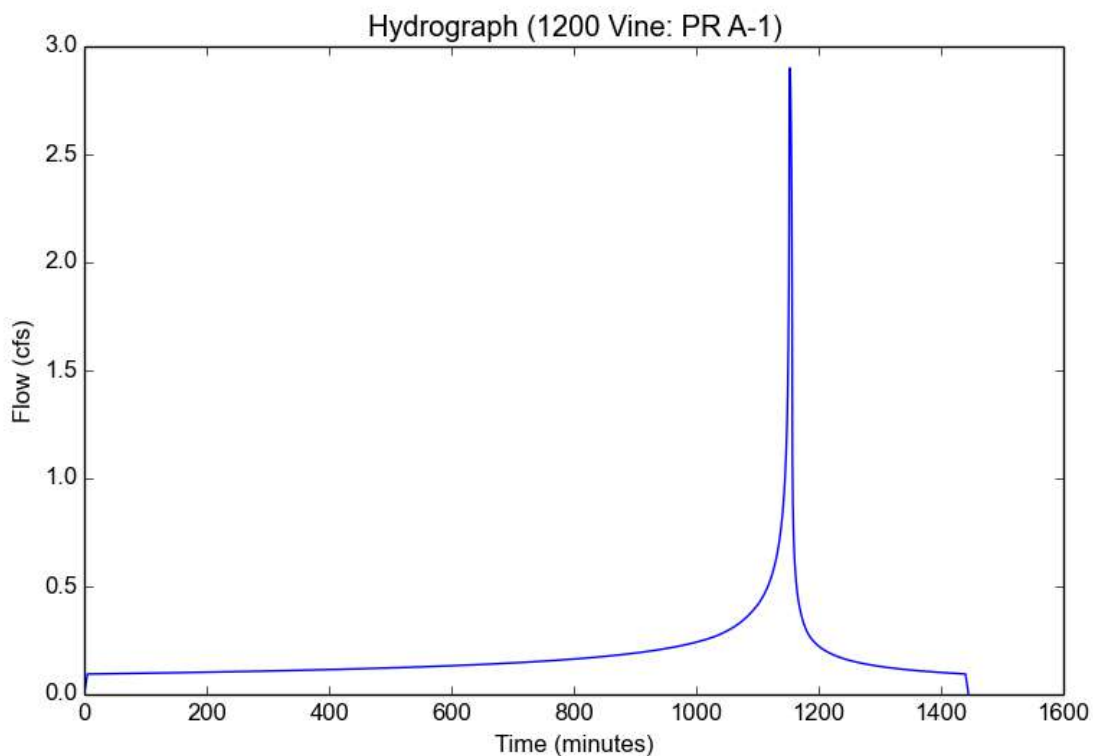

ATTACHMENT I

LA COUNTY GIS 85TH PERCENTILE MAP

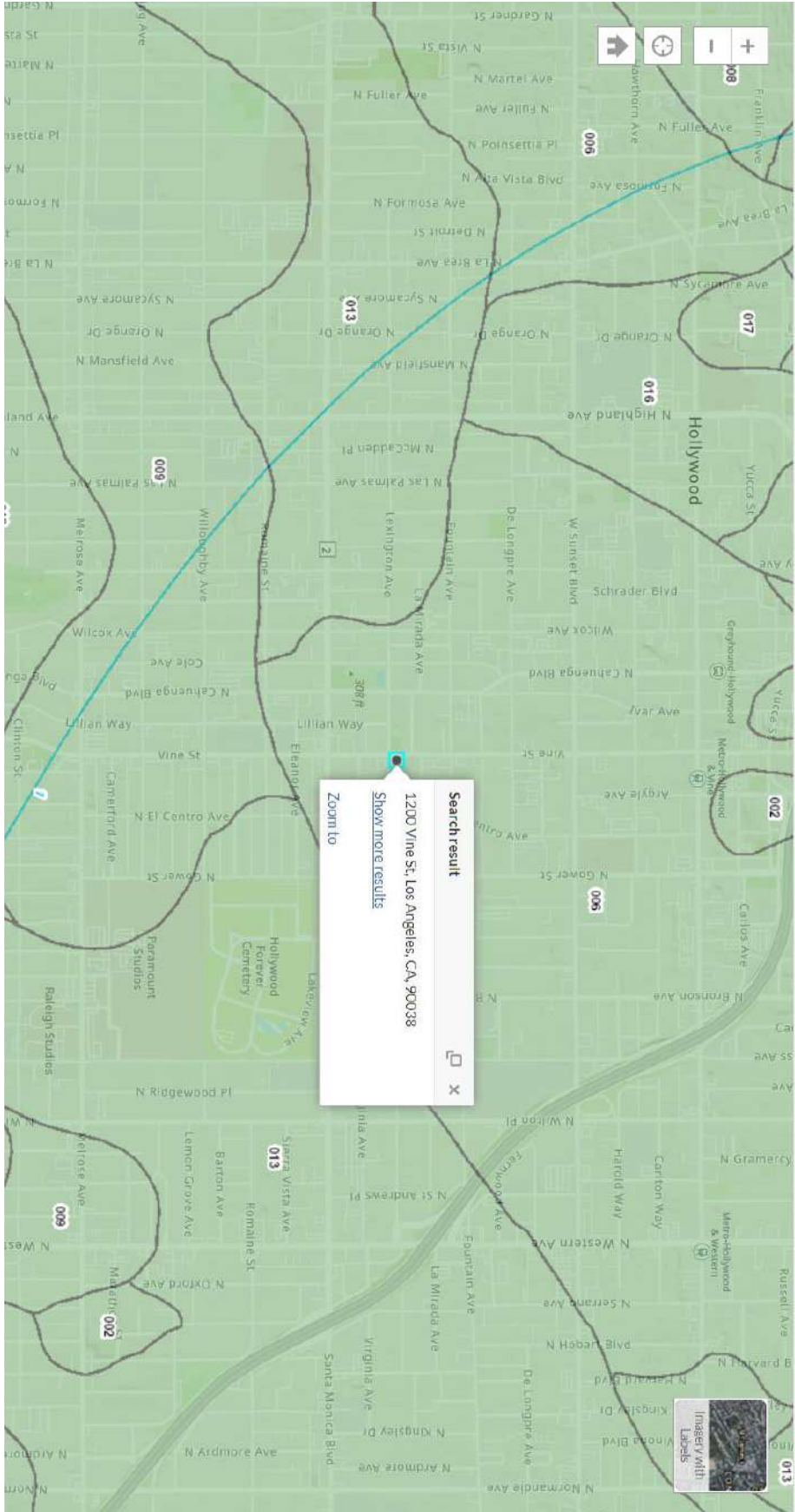

Search result
1200 Vine St, Los Angeles, CA, 90038
[Show more results](#)
Zoom to

BOARD OF COMMISSIONERS

SYLVIA PATSAOURAS
PRESIDENT

LYNN ALVAREZ
VICE PRESIDENT

TAFARAI BAYNE
NICOLE CHASE
JOSEPH HALPER

TAKISHA SARDIN
BOARD SECRETARY
(213) 202-2640



ERIC GARCETTI
MAYOR

JIMMY KIM
GENERAL MANAGER

MATTHEW RUDNICK
EXECUTIVE OFFICER

ANTHONY-PAUL (AP) DIAZ, ESQ.
ASSISTANT GENERAL MANAGER

CATHIE SANTO DOMINGO
ASSISTANT GENERAL MANAGER

BELINDA JACKSON
ACTING ASSISTANT GENERAL MANAGER

(213) 202-2633 FAX (213) 202-2614

September 22, 2022

Sherrie Cruz
CAJA Environmental Services, LLC
9410 Topanga Canyon Blvd., Suite 101
Chatsworth, CA 91311

**REQUEST FOR INFORMATION REGARDING RECREATIONAL AND PARK SERVICES FOR
THE 1200 VINE PROJECT IN THE CITY OF LOS ANGELES**

Dear Ms. Cruz:

The following has been prepared in response to your request for Recreation and Parks information relative to the proposed 1200 Vine Project. This project proposes the development of a residential project with 153 residential dwelling units on a site generally located at 1200, 1204, 1214, 1218 N. Vine Street, 6245, 6247 W. Lexington Avenue, in the Hollywood Community Plan.

1. Which parks and recreational facilities would serve the proposed project?

The following Department of Recreation and Parks facilities are classified as neighborhood parks and are located within a two-mile radius of the project site:

- Cahuenga Elementary Community School Park, located at 220 South Hobart Boulevard.
- Carlton Way Park, located at 5927 West Carlton Way.
- De Longpre Park, located at 1350 North Cherokee Avenue.
- Dorothy J & Benjamin B. Smith Park, located at 7020 West Franklin Avenue.
- Harvard Elementary Community School Park, located at 330 North Harvard Boulevard.
- La Mirada Avenue Park, located at 5401 West La Mirada Avenue.
- Lexington Avenue Pocket Park, located at 5523 West Lexington Avenue.
- Robert L. Burns Park, located at 4900 West Beverly Boulevard.
- Seily Rodriguez Park, located at 5707 West Lexington Avenue.
- Selma Park, located at 6567 West Selma Avenue.

The following Department of Recreation and Parks facilities are classified as community parks and are located within a five-mile radius of the project site:

- Barnsdall Park, located at 4800 West Hollywood Boulevard.
- Bellevue Recreation Center, located at 826 North Lucille Avenue.
- Chevy Chase Park, located at 4165 East Chevy Chase Drive.



- Claude and Pepper Senior Citizen Center, located at 1762 South La Cienega Boulevard.
- Denker Recreation Center, located at 1550 West 35th Place.
- Echo Park, located at 751 North Echo Park Boulevard.
- Eleanor Green Roberts Aquatic Center, located at 4526 West Pico Boulevard.
- Elysian Valley Recreation Center, located at 1811 West Ripple Street.
- Fairfax Senior Citizen Center, located at 7929 West Melrose Avenue.
- Hollywood Recreation Center, located at 1122 North Cole Avenue.
- Hoover Recreation Center, located at 1010 West 25th Street.
- Lafayette Park, located at 625 South Lafayette Park Place.
- Lake Street Community Center, located at 227 North Lake Street.
- Las Palmas Senior Citizen Center, located at 1820 North Las Palmas Avenue.
- Lemon Grove Recreation Center, located at 4959 West Lemon Grove Avenue.
- Loren Miller Recreation Center, located at 2717 South Halladale Avenue.
- MacArthur (General Douglas) Park, located at 2230 West 6th Street.
- Normandie Recreation Center, located at 1550 South Normandie Avenue.
- Pan Pacific Park, located at 7600 West Beverly Boulevard.
- Poinsettia Recreation Center, located at 7341 West Willoughby Avenue.
- Queen Anne Recreation Center, located at 1240 South West Boulevard.
- Rancho Cienega Sports Complex, located at 5001 West Obama Boulevard.
- Robertson Recreation Center, located at 1641 South Pruess Road.
- Seoul International Park, located at 3250 West San Marino Street.
- Shatto Recreation Center, located at 3191 West 4th Street.
- Silverlake Recreation Center, located at 1850 North Silver Lake Drive.
- South Seas House Park, located at 2301 West 24th Street.
- Toberman Recreation Center, located at 1725 South Toberman Street.
- Tommy Lasorda Field of Dreams, located at 1901 North Waterloo Street.
- Vineyard Recreation Center, located at 2942 South Vineyard Avenue.
- Vista Hermosa Soccer Field, located at 1301 West 1st Street.
- Weddington Park North, located at 10844 West Acama Street.
- Weddington Park South, located at 10600 West Valleyheart Drive.
- Yucca Community Center, located at 6671 West Yucca Street.

The following Department of Recreation and Parks facilities are classified as regional parks and are located within a ten-mile radius of the project site:

- Ascot Hills Park, located at 4371 East Multnomah Street.
- Beverly Glen Park, located at 2448 North Angelo Drive.
- Campo de Cahuenga, located at 3919 North Lankershim Boulevard.
- Charles F. Lummis Home, located at 200 East Avenue 43.
- Coldwater Canyon Park, located at 12601 North Mulholland Drive.
- Deervale-Stone Canyon Park, located at 14890 West Valley Vista Boulevard.
- Eagle Rock Hillside Park, located at 2747 South Valle Vista Drive.
- Elysian Park, located at 929 West Academy Road.
- Ernest E Debs Regional Park, located at 4235 North Monterey Road.

- Exposition Park Rose Garden, located at 701 West State Drive.
- Griffith Park, located at 4730 North Crystal Springs Drive.
- Heritage Park, located at 3800 North Homer Street.
- Holmby Park, located at 601 South Club View Drive.
- La Tuna Canyon Park, located at 6801 North La Tuna Canyon Road.
- Laurel Canyon Mulholland Park, located at 8100 West Mulholland Drive.
- Rose Hill Park, located at 3606 North Boundary Avenue.
- Runyon Canyon Park, located at 2000 North Fuller Avenue.
- Sepulveda Basin Recreation Area, located at 17017 West Burbank Boulevard.
- Verdugo Mountain Park, located at 9999 South Edmore Place.
- Villa Cabrini Park, located at 9401 West Cabrini Drive.
- Wattles Garden Park, located at 1824 North Curson Avenue.

For additional information regarding facilities and features available in these parks visit our website: www.laparks.org.

2. *Does the City have any plans to develop new parks or recreational facilities or expand existing parks or recreational facilities within a two-mile radius of the project site?*

The City plans to demolish the existing gymnasium building and construct a new modern gymnasium at Hollywood Recreation Center. The project is in the design phase.

3. *What is the area's existing parkland acres-to-population ratio and what is the desired acres-to-population ratio?*

The Hollywood Community Plan Area, within which the project is located, has a parkland acres-to-population ratio of neighborhood and community parks of 0.41 acres per 1,000 residents. The Public Recreation Plan, a portion of the Service Element of the City's General Plan, sets a goal of a parkland acres-to-population ratio of neighborhood and community parks of 4.0 acres per 1,000 residents.

Thank you for the opportunity to provide information relative to the proposed project's impact on recreation and park services. Most subdivision projects that contain more than fifty residential dwelling units are required to meet with the Department of Recreation and Parks prior to filing in order to discuss any potential dedication requirements. If you have any questions or comments regarding this information, please contact the RAP Park Staff at (213) 202-2682 or rap.parkfees@lacity.org

Sincerely,

CATHIE M. SANTO DOMINGO
Assistant General Manager



DARRYL FORD
Superintendent

Service Information Response Letter – The 1200 Vine Project
September 22, 2022
Page 4

Planning, Maintenance, and Construction Branch

CSD/DF:am

cc: Reading File



WATER AND WASTEWATER TECHNICAL REPORT

1200 Vine Street

1200 – 1218 N Vine Street
6245 – 6247 W Lexington Avenue
Los Angeles, California 90038

Prepared For

*Vine Street Los Angeles Apartments, LLC
4601 Park Road, Suite 450
Charlotte, NC 28209*

Prepared By

Fusco Engineering, Inc.
600 Wilshire Blvd., Ste. 1470
Los Angeles, California 90017
213.988.8802
www.fusco.com

Project Manager:
Samson E. Kawjaree, PE
C-83863

Date Prepared: November 29, 2022

Job Number: 4103.001



TABLE OF CONTENTS

1. INTRODUCTION	3
1.1 PROJECT DESCRIPTION	3
1.2 SCOPE OF WORK	4
2. REGULATORY FRAMEWORK	5
2.1 WATER	5
2.2 SEWER	5
3. ENVIRONMENTAL SETTING	6
3.1 WATER	6
3.1.1 REGIONAL	6
3.1.2 LOCAL	6
3.1.3 ON-SITE	6
3.2 WASTEWATER	7
3.2.1 REGIONAL	7
3.2.2 LOCAL	7
3.2.3 ON-SITE	7
4. METHODOLOGY	9
4.1 WATER	9
4.2 WASTEWATER	9
5. PROJECT SERVICES	11
5.1 construction	11
5.1.1 WATER	11
5.1.2 WASTEWATER	11
5.2 OPERATION	12
5.2.1 WATER	12
5.2.1.1 WATER CONSUMPTION	12
5.2.1.2 WATER INFRASTRUCTURE ASSESSMENT	13
5.2.1.3 FIRE FLOW REQUIREMENTS	13
5.2.2 WASTEWATER	14
5.2.2.1 SEWER GENERATION	14
5.2.2.2 INFRASTRUCTURE CAPACITY	15
6. PROJECT SERVICABILITY	16

LIST OF TABLES

Table 1 – Estimated Existing Water Demand	6
Table 2 – Estimated Existing Wastewater Generation.....	8
Table 3 – Estimated Proposed Water Demand.....	12
Table 4 – Estimated Proposed Wastewater Generation.....	14

LIST OF ATTACHMENTS

- Attachment A – Information of Fire Flow Availability (IFFA)
- Attachment B – Fire Service Pressure Flow Report (SAR)
- Attachment C – Water Service Will Serve Letter
- Attachment D – City of Los Angeles, LABOS – Will Serve Letter
- Attachment E – Sewer Capacity Availability Report (SCAR)

1. INTRODUCTION

1.1 PROJECT DESCRIPTION

Vine Street Los Angeles Apartments, LLC (Applicant) is proposing to develop a new mixed-use residential development (Project) on an approximate 0.94-acre site, located at 1200 – 1218 N Vine Street and 6245 – 6247 W Lexington Avenue in the City of Los Angeles. The Project proposes an 8 – story structure with two levels of above ground parking. The Project will include 153 residential units (21 – Studio, 89 – 1 Bedroom, 43 – 2 Bedroom) on six levels of residential housing, 7,000 square feet of high-turnover sit-down restaurant areas, 13,919 square feet of amenity areas (indoor and outdoor open spaces and gym/fitness facility), and parking areas (78 – Residential Spaces, 15 – Commercial Spaces).

The existing Project Site consists of two, 1 – story concrete buildings with the remainder of the site being a paved surface parking lot. There are also existing concrete masonry unit perimeter walls and fencing that run along the entire western, and southern perimeters of the paved parking. Based upon the proposed building program, the existing building structure, foundations, parking lot surface, fencing, walls, gates, and all existing flatwork will need to be demolished. This includes the existing signs, guard post, handrails, ramps, and light fixtures within the parking lot area of the Project Site. The Project will consist of a redevelopment of the existing parking lot and commercial building into a multi-family mixed-use apartment and commercial building.

The project is bounded by a Commercial Development that continues to La Mirada Avenue to the North, Commercial and Residential Developments that continue to El Centro Avenue to the East, Lexington Avenue to the South, and Vine Street to the West.



Project Site: Thomas Grid - Page 593 – Grid F5

1.2 SCOPE OF WORK

As part of the California Environmental Quality Act (CEQA) analysis for the Project, the purpose of this report is to analyze the potential impacts of the Project upon the existing water and wastewater infrastructure systems. The current location of existing water and wastewater infrastructure, analysis of any potential Project impacts this infrastructure, and any applicable mitigation measures will be discussed in this technical report.

2. REGULATORY FRAMEWORK

2.1 WATER

The Project Site receives water supply from the Los Angeles Department of Water and Power (LADWP), the primary water purveyor for the City. As the primary supplier of water to the City, LADWP must comply with all applicable regulations at the State and Federal level. Applicable regulations affecting LADWP as a supplier of water include efficiency requirements, such as California Code of Regulations (CCR) Title 20, Chapter 4, Article 4, Section 1605, which requires all new plumbing fixtures to adhere to efficiency requirements, and CCR Title 24, Part 11, which requires a water use reduction of 20% above baseline for all homes, commercial, and state buildings.

The regulations also include reporting requirements, such as the California Urban Water Management Planning Act (1984) and Senate Bill (SB) 610. The California Urban Water Management Planning Act requires that municipalities and other water suppliers must create an updated Urban Water Management Plan (UWMP) every five years, outlining anticipated trends in supply and demand for the planning period. LADWP's most recent UWMP update was in 2020 and identified adequate supplies to match modeled demands through 2045¹. SB 610 requires water suppliers to submit a Water Supply Assessment (WSA) for all projects that propose over 500 dwelling units, 500,000 square feet of commercial floor space, or employ over 1,000 individuals or the equivalent water usage. The Project falls below the requirements of a WSA, and therefore a WSA will not be required for the Project.

2.2 SEWER

The Project Site is located in the City of Los Angeles, and therefore falls under the jurisdiction of the Los Angeles Bureau of Sanitation (BOS) of the City of Los Angeles Department of Public Works. The BOS serves over four million customers, and its sewer system is split into three subsystems – the Hyperion Sanitary Sewer System, the Terminal Island Water Reclamation Plant Sanitary Sewer System, and Regional Sanitary Sewer System. The Project Site lies within the Hyperion Sanitary Sewer System service area ("Hyperion"). Projects that discharge into the Hyperion system must follow the regulations under Ordinance No. 166,060 adopted by the City in 1990. This ordinance established an additional annual allotment of 5 million gallons per day (mgd), of which it allocates 1.7 mgd for priority projects, 0.4 mgd for public benefit projects, and 2.9 mgd for non-priority projects.

Under the City of Los Angeles Municipal Code ("Municipal Code"), all new projects connecting to the sewer collection system or proposing additional discharge must have a Sewer Capacity Availability Request (SCAR) performed by the City (Section 64.15, Municipal Code). The SCAR analyzes existing sewer system to determine whether the proposed increases in wastewater flows will generate any capacity issues. New connections to the sewer system must also pay associated fees (Sewerage Facilities Charge) based upon flow strength and volume (Section 64.11.2, Municipal Code). Pursuant to the City's design criteria, any new sewer laterals less than 18" must be designed for a 100-year planning period, and depth of peak dry weather flows shall not exceed one half the diameter of the pipe ($d/D=0.5$).

¹ https://www.ladwp.com/ladwp/faces/ladwp/aboutus/a-water/a-w-sourcesofsupply/a-w-sos-uwmpln?_adf.ctrl-state=ujj2662lo_79&_afLoop=485979579825357

3. ENVIRONMENTAL SETTING

3.1 WATER

3.1.1 REGIONAL

As mentioned, the City of Los Angeles Department of Water and Power (LADWP) maintains water infrastructure serving the Project area and provides domestic water service to the Project Site. LADWP receives water from the Los Angeles Aqueduct (LAA), local groundwater supply, the State Water Project (SWP) and the Colorado River Aqueduct (CRA); the latter two supplied by the Metropolitan Water District of Southern California (MWD). Over the past 20 years, water supplies from the LAA have decreased due to environmental concerns resulting in more dependency on other sources of water. Approximately 57% of supplies have come from imported SWP and CRA supplies from MWD. Approximately 12% of LADWP water supplies come from local groundwater.

3.1.2 LOCAL

Available record drawings provided by the City show there are current water meters connecting to the 10-inch water main along Vine Street, to the west of the Project Site, and the 4-inch water line on Lexington Avenue. The record drawings indicate the following existing water infrastructure: a 10-inch line on Vine Street, 4-inch line on Lexington Avenue.

3.1.3 ON-SITE

As described above, the Project Site is currently occupied by two, 1 – story concrete retail buildings, surface parking and perimeter walls. Table 1 shows the estimated existing water demand for the Project Site, prepared based on 100 percent of the City of Los Angeles BOS wastewater generation factors for non-residential categories. This estimate is appropriate given the fact that there is no existing landscaping on-site that would deviate from the LABOS sewage generation factors.

Table 1 – Estimated Existing Water Demand

Land Use	Building Square Footage	Est. Avg. Daily Consumption Flow Rate Factor (gal/1000 SF gross area) ¹ (gpd/unit)	Total Average Daily Consumption (gpd)
Retail (2 Bldgs.)	27,011 ²	25	675
Total Existing Water Demand			675
Notes:			
¹ Based on 100% of the BOS sewer generation factors for Retail Areas less than 100,000 SF			
² Number based off City of LA ZIMAS portal			

There are currently five (5) existing fire hydrants located within 300 feet of the Project Site; two (2) hydrants are along Vine Street, two (2) hydrants are along La Mirada Avenue, and one (1) is along Lexington Avenue. The hydrants are served by the main lines on Vine Street, Lexington Avenue and La Mirada Avenue. The Project Site is located in a Commercial and High Density Residential Zone, which requires 4,000 gallons per minute (gpm) from four (4) hydrants flowing simultaneously as stated in the City of Los Angeles Municipal Code (LAMC), therefore, only four (4) fire hydrants out of the five (5)

within 300 feet of the Project Site will need to be tested. The existing fire hydrants will be tested to find if adequate for High Density Residential flows, running four (4) simultaneous hydrants with at least 4,000 total gpm.

An application for Information of Fire Flow Availability Request (IFFAR) was received 09.14.2022 (See **Attachment A – Information of Fire Flow Availability (IFFA)**). The existing hydrants were tested at 1,500 gpm each, resulting in residual pressures of 90 to 92 pounds per square inches (psi).

The Fire Service Pressure Flow report (SAR) application was received 09.16.2022. The SAR applications confirm that the existing water main in Vine Street was found to be adequate for the proposed required flows of 1,400 gpm, having a pressure of 88 psi, however, the existing water main in Lexington Avenue would require upsizing to achieve a required flow of 1400 gpm at this Project Site location (See **Attachment B – Fire Service Pressure Flow Report (SAR)**).

3.2 WASTEWATER

3.2.1 REGIONAL

The Bureau of Sanitation (BOS) of the City of Los Angeles Department of Public Works provides sanitary sewer service to the Project Site through a sewer system in the surrounding streets. Wastewater from the Project Site ultimately flows to the Hyperion Treatment Plant (HTP) system. The One Water LA – Wastewater Facilities Plan notes that the existing design capacity of the Hyperion Water Reclamation Plant is 450 mgd. The projected average wastewater daily flow for the system for 2030 (buildout year for proposed Project) is approximately 275 mgd².

3.2.2 LOCAL

There are currently four (4) existing sewer mains in the surrounding streets. Two (2) of these mains, a 12-inch and 8-inch, reside in Lexington Avenue and the other two (2), a 10-inch and 33-inch, reside in Vine Street. Beyond the limits of the Project Site, the sewer mains on Vine Street continue to flow southerly while the sewer mains on Lexington Avenue flow westerly. Each of these sewer mains that are adjacent to the Project Site connect to a network of sewer lines that ultimately convey wastewater to the City's Hyperion Treatment Plant.

3.2.3 ON-SITE

Based on available record data from the City, there is currently one existing sewer lateral connecting from the City's public sewer system to the Project Site. The sewer lateral, marked as active, connects to the 8-inch main on Lexington Avenue.

Table 2 shows the estimated existing wastewater generation for the Project Site, based on BOS wastewater generation factors.

²One Water LA 2040 Plan (Volume 2 Wastewater Facilities Plan), Found here:
https://www.lacitysan.org/cs/groups/sg_owla/documents/document/y250/mdi2/~edisp/cnt026205.pdf

Table 2 – Estimated Existing Wastewater Generation

Land Use	Building Square Footage	Est. Avg. Daily Sewage Flow Rate Factor (gal/1000 SF gross area) ¹ (gpd/unit)	Total Average Daily Consumption (gpd)
Retail (2 Bldgs.)	27,011 ²	25	675
Total Existing Wastewater Demand			675
Notes:			
¹ Based on 100% of the BOS sewer generation factors			
² Number based off City of LA ZIMAS portal			

The BOS requires a SCAR (See **Attachment E – Sewer Capacity Availability Report (SCAR)**) be conducted prior to determining the adequacy of the current facilities to accommodate for the additional sewage. In summary, the SCAR found that the existing sewer lines were able to accommodate for the additional sewage from the proposed Project.

4. METHODOLOGY

4.1 WATER

The methodology for determining the significance of a project as it relates to a project's impact on water supply and distribution infrastructure is based on the *City of Los Angeles CEQA Thresholds Guide*. This methodology involves a review of the project's environmental setting, project impacts, cumulative impacts, and mitigation measures as required. The following has been considered as part of the determination for this Project:

Environmental Setting

- Description of major water infrastructure serving the Project Site, including the type of facilities, location and sizes, and any planned improvements
- Description of the water conditions for the Project area and known improvement plans

Project Impacts

- Evaluate the Project's water demand, considering design or operational features that would reduce/offset water demand.
- Determine what improvements would be needed, if any, to adequately serve the Project.
- Describe the degree to which presently scheduled off-site improvements offset impacts.

This report analyzes the potential impacts of the Project on the existing public water infrastructure by comparing the estimated Project demand with the calculated available capacity of the existing facilities.

To justify that the water demand shall be adequately serviced to the property, based on available site and occupancy information, 100% of the BOS sewer generation factors were employed to estimate the existing water consumption. In addition, LADWP performed a flow test to determine if available water conveyance exists for future development. LADWP's approach consists of data ranging from available static pressure (how much pressure is available at the source before applying the Project's demand), to the available pressure at the maximum demand needed for the Project.

An Information of Fire Flow Availability report (IFFA) is also conducted by LADWP to determine that there is sufficient hydrant flow from existing or proposed hydrants fronting the project based on the existing infrastructure. Additionally, a LADWP Water Pressure application for Fire Service Pressure Flow Report (SAR) is done for the Project to achieve a preliminary analysis of the existing water mains in Vine Street and Lexington Avenue. The results of the SARs determine if the existing mains can convey water supply for both the proposed Project demand of domestic and fire water services.

4.2 WASTEWATER

The methodology for determining the significance of a project as it relates to a project's impact on wastewater collection and treatment infrastructure is based on the *City of Los Angeles CEQA Thresholds Guide*. This methodology involves a review of the project's environmental setting, project impacts, cumulative impacts, and mitigation measures as required. The following has been considered as part of the determination for this Project:

Environmental Setting

- Location of the Project and appropriate points of connection to the wastewater collection system on the pertinent Sewer Wye Map;
- Description of the existing wastewater system which would serve the Project, including its capacity and current flows.

Project Impacts

- Evaluate the Project wastewater needs (anticipated daily average wastewater flow), taking into account design or operational features that would reduce or offset service impacts;
- Compare the Project's wastewater needs to the appropriate sewer's capacity and/or the wastewater flows anticipated in the Wastewater Facilities Plan or General Plan.

This report analyzes the potential impacts of the Project on the existing public sewer infrastructure by comparing the estimated Project demand with the calculated available capacity of the existing facilities.

To justify that the wastewater collection shall be adequately serviced, the BOS Wastewater Engineering Division made a preliminary analysis of the local and regional sewer conditions to determine if available wastewater conveyance and treatment capacity exists for future development. The BOS approach consisted of the study of a worst-case scenario envisioning peak demands from the relevant facilities occurring simultaneously on the wastewater system. A combination of flow gauging data and computed results from the City's hydrodynamic model were used to project current and future impacts due to additional sewer discharge. The data used in this report are based on the findings of the BOS's preliminary analysis. The analysis is based on the Sewer Capacity Availability Report (SCAR) application processed 11.08.2022 (See **Attachment E – Sewer Capacity Availability Report (SCAR)**).

5. PROJECT SERVICES

5.1 CONSTRUCTION

A Construction Management Plan, which would ensure safe pedestrian access as well as emergency vehicle access and safe vehicle travel in general, will be implemented to reduce any temporary pedestrian and traffic impacts occurring as a result of construction activities.

5.1.1 WATER

During construction, water will be required intermittently for dust control, equipment cleaning, soil grading and preparation during the early phases of the project. The latter phases of construction normally require less water usage. Since water usage during construction is typically less demanding than the water usage for the proposed Project, it is anticipated that existing water infrastructure would meet the limited, temporary water demand associated with construction of the Project, and that the water purveyor is able to provide water during construction. Therefore, impacts to water infrastructure due to construction activity is considered less than significant.

The Project will require decommission/abandonment of existing water lines to the site, and construction of new on-site water distribution lines to serve new buildings, as well as the potential relocation of existing lines. Prior to buildout of the water system, during construction, with approval from LADWP and the City, temporary water supply needs during construction may be obtained from metered connections from existing metered water connections or fire hydrants. Construction impacts associated with the installation of water distribution lines would primarily involve trenching in order to place the lines below surface. Installation of new water infrastructure will be limited to on-site water distribution and minor off-site work associated with connections to the public main. No upgrades to public water mains are anticipated. Prior to ground disturbance, Project contractors would coordinate with LADWP to identify the locations and depth of all lines. Further, LADWP would be notified in advance of proposed ground disturbance activities to avoid existing water lines and disruption of water service. Therefore, Project impacts on water infrastructure associated with construction activities would be less than significant.

5.1.2 WASTEWATER

Construction activities for the Project could result in a temporary increase in wastewater generation on-site. However, such use would be temporary and nominal when compared with the wastewater generated by the Project. In addition, construction workers would not contribute to direct wastewater flows to the City's wastewater system. Thus, wastewater generation from Project construction activities is not anticipated to cause any measurable increase in wastewater flows. Therefore, the Project's construction impacts to the wastewater system would be less than significant.

The Project will require abandonment of existing sewer lines to the site and construction of new on-site wastewater infrastructure to serve the proposed new building, and potential upgrade and/or relocation of existing wastewater infrastructure. Construction impacts associated with wastewater infrastructure would primarily be confined to trenching for miscellaneous utility lines and connections to public infrastructure. Installation of wastewater infrastructure will be limited to on-site wastewater distribution and minor off-site work associated with connections to the public main. No upgrades to the public main

are anticipated. Any work that may affect services to the existing sewer lines will be coordinated with the City of Los Angeles.

Moreover, when considering impacts resulting from the installation of any required wastewater infrastructure, all impacts are of a relatively short-term duration (i.e., months) and would cease to occur once the installation is complete. Therefore, Project impacts on wastewater associated with construction activities would be less than significant.

5.2 OPERATION

This section covers the long-term operation of the proposed project and its impact to water and sewer, Construction impacts, prior to operation, for both water and wastewater are temporary and less than long term operational demands. Therefore, it is anticipated that no service issues shall occur during construction.

5.2.1 WATER

5.2.1.1 WATER CONSUMPTION

Based on the Project's land uses, the Project's estimated water consumption is approximately 53,670 gallons per day (gpd), resulting in a net increased water demand of 52,545 gpd. These demand numbers were calculated using 100 percent of the BOS corresponding wastewater generation factors. A breakdown of these water demand calculations is provided in Table 3.

Table 3 – Estimated Proposed Water Demand

Land Use	Unit	Est. Avg. Daily Consumption Flow Rate Factor (gal/1000 SF gross area) ¹ (gpd/unit)	Total Average Daily Consumption (gpd)
Residential: Apt – 1 Bedroom	89 Units	110 /Unit	9,790
Residential: Apt – 2 Bedroom	43 Units	150 /Unit	6,450
Residential: Studio (Bachelor)	21 Units	75 /Unit	1,575
Restaurant: ²	7,000 SF (approx. 235 seats) ³	25 /Seat	5,875
Pool:	1 Unit	29,330 /Unit	29,330
Gym:	1,000 SF	650 /1000 SF	650
Total Proposed Water Demand			53,220
Total Existing Water Demand (Per Table 1)			675
Project Net Water Demand (Proposed – Existing)			52,545
Notes:			
¹ Based on 100% of the BOS Sewer Generation Factors			
² High-turnover Sit-down Restaurant			
³ Assumes 50% of Restaurant Space Will be Usable Seating Area and 15 Square Feet per Seat			

5.2.1.2 WATER INFRASTRUCTURE ASSESSMENT

To determine the ability to provide on-site water service to the Project, a Fire Service Pressure Flow Report (SAR) was submitted to LADWP to analyze if there is adequate water capacity within both the fire suppression system (i.e. building sprinkler system), and domestic water service. Two locations were analyzed for the capacity to provide water service simultaneously for the onsite domestic water service and fire suppression system. One location was the 10-inch water main on Vine Street and the other was the 4-inch water main on Lexington Avenue. The SAR analysis received confirmed that there is sufficient water service capacity for the Project demand. Proposed water service can be connected from the existing 10-inch water main in Vine Street that has the capacity for water pipe infrastructure. The expected water demand of the project will require a 6-inch domestic water service and a 6-inch fire water service connection. The location on Lexington Avenue was not able to achieve 1400 gpm, the maximum flow achieved was 800 gpm at a pressure of 58 psi. However, per LADWP, the upsizing of the 4-inch pipe to a 6-inch pipe at this location would result in the capacity to achieve flows of 1400 gpm. The upsizing would allow for there to be adequate water capacity to provide on-site water service to the Project. Therefore, the proposed project will plan to connect into the water main in Vine Street. The service laterals will be adequately sized to accommodate the on-site fire suppression system demand and domestic demand flowing simultaneously. The new water services will also include backflows and be metered separately per City requirements. Therefore, impacts on water infrastructure would be less than significant (See **Attachment B – Fire Service Pressure Flow Report (SAR)**).

A Will Serve Letter was also requested to LADWP in order to confirm if the Project demand can be sufficiently supplied. The Will Serve Letter dated 08.29.2022 confirmed that the proposed Project Site can be supplied with water from the municipal system (See **Attachment C – Water Service Will Serve Letter**). Therefore, from the affirming Will Serve Letter and received SARs, the existing infrastructure can be determined to be adequate to serve the Project.

5.2.1.3 FIRE FLOW REQUIREMENTS

Article 7 Fire Protection and Prevention, Section 57.507.3 of the LAMC sets the fire flow requirements for the Project. These guidelines, in addition to the requirements set by the City Fire Chief, will prescribe the fire flow requirements (pressure and duration) and hydrant spacing requirements for the Project.

The Project shall not require additional fire hydrants to be installed in or around the property. The surrounding hydrants on Lexington Avenue, La Mirada Avenue, and Vine Street would be adequate. The Project falls within the High Density Residential and Neighborhood Commercial category, which has a required fire flow of 4,000 gallons per minute (gpm) from four adjacent fire hydrants flowing simultaneously, per City of Los Angeles Fire Code Table 507.3.1. Ultimate Fire flow requirements will be governed by the Fire Department.

Adjacent to the site there are currently five (5) existing fire hydrants located within 300 feet of the Project Site boundary. Four hydrants were analyzed with flows of 1,500 gpm each, resulting in residual pressures of 90 – 92 psi. The existing water mains and hydrants surrounding the Project will adequately service the minimum 4,000 gpm from four (4) hydrants running simultaneously (See **Attachment A – Information of Fire Flow Availability (IFFA)**).

5.2.2 WASTEWATER

5.2.2.1 SEWER GENERATION

In accordance with the *City of Los Angeles CEQA Thresholds Guide*, the Project’s estimated sewer flows were based on the BOS’s sewage generation factors for residential categories. Based on the proposed uses and generation factors, the Project’s projected wastewater generation is approximately 53,220 gpd, representing a net increase in wastewater generation at the Project Site of approximately 52,545 gpd. A summary of the wastewater generation calculations is provided in Table 4.

Table 4 – Estimated Proposed Wastewater Generation

Land Use	Unit	Est. Avg. Daily Sewage Flow Rate Factor (gal/1000 SF gross area) ¹ (gpd/unit)	Total Average Daily Consumption (gpd)
Residential: Apt – 1 Bedroom	89 Units	110 /Unit	9,790
Residential: Apt – 2 Bedroom	43 Units	150 /Unit	6,450
Residential: Studio (Bachelor)	21 Units	75 /Unit	1,575
Restaurant: ²	7,000 SF (approx. 235 seats) ³	25 /Seat	5,875
Pool:	1 Unit	29,330 /Unit	29,330
Gym:	1,000 SF	200 /1000 SF	200
Total Proposed Wastewater Demand			53,220
Total Existing Wastewater Demand (Per Table 1)			675
Project Net Wastewater Demand (Proposed – Existing)			52,545
Notes:			
¹ Based on 100% of the BOS Sewer Generation Factors			
² High-turnover Sit-down Restaurant			
³ Assumes 50% of Restaurant Space Will be Usable Seating Area and 15 Square Feet per Seat			

The total proposed wastewater demand for the Project is 53,220 gpd. The Sewage Facility Charge (SFC) is based on the net wastewater demand, therefore 675 gpd from the existing retail buildings were subtracted in order to get 52,545 gpd.

A Sewer Capacity Availability Request (SCAR) was submitted to the BOS to determine whether the existing wastewater infrastructure can accommodate the Project location (See **Attachment E – Sewer Capacity Availability Report (SCAR)**). BOS has analyzed the Project demands of a prior, more demanding Project scheme in conjunction with existing conditions and forecasted growth. The Project was approved to discharge up to 48,666 gpd into the city’s system by connecting to the existing sewer lines in Vine Street and Lexington Avenue. A new SCAR was filed with a proposed total flow of 53,220 gpd. The original SCAR submitted was approved for a total of 48,666 gpd but will need to be amended to account for an additional 4,554 gpd. The results from the approved new SCAR, determined there are no wastewater service issues and the Project’s wastewater infrastructure is serviceable.

5.2.2.2 INFRASTRUCTURE CAPACITY

The sewer mains in Vine Street and Lexington Avenue will serve the Project, and sewage from the Project Site is conveyed to the City's Hyperion Treatment Plant. The BOS's most current Integrated Resources Plan (IRP) notes that the existing design capacity of the Hyperion Service Area is approximately 550 mgd (consisting of 450 mgd at the Hyperion Treatment Plant, 80 mgd at the Donald C. Tillman Water Reclamation Plant, and 20 mgd at the Los Angeles-Glendale Water Reclamation), and that the existing average daily flow for the system as of 2021 is approximately 275 mgd. The Project's estimated wastewater generation increase of 52,545 gpd, or 0.052 mgd, comprises of less than 0.02 percent of the available capacity in the system and is within the system's remaining capacity of 275 mgd.

Based on these forecasts, the Project's increase in wastewater generation would be adequately accommodated by the Hyperion Service Area. In addition, the BOS's analysis confirms that the Hyperion Water Reclamation Plant has sufficient capacity and regulatory allotment for the proposed Project. Thus, operation of the Project would have a less than significant impact on wastewater treatment facilities. Related projects must go through the same analysis to determine if any facilities will need to be upgraded to accommodate for the increase in capacity. Therefore, based on the approved SCAR for the Project and the available wastewater treatment capacity, the Project's wastewater infrastructure would be serviceable.

6. PROJECT SERVICABILITY

Based on the results of the SAR, IFFAR and SCAR and the analysis contained in this report, no further service issues have been identified. The existing wastewater and water infrastructure shall be adequate to serve the proposed project. Additionally, less than significant water and wastewater impacts have been identified for this Project.

ATTACHMENT A

INFORMATION OF FIRE FLOW AVAILABILITY (IFFA)



City of Los Angeles

Los Angeles Department of Water and Power - Water System

INFORMATION OF FIRE FLOW AVAILABILITY

Western

LAFD Fire Flow Requirement: 4,000 GPM (from 4 Hydrants) Water Service Map No.: 146-189
 LAFD Signature: _____
 Date Signed: _____

Applicant: Alejandra Santos
 Company Name: Fusco Engineering
 Address: 600 Wilshire Blvd, Suite 1470, Los Angeles, CA 90017
 Telephone: 213-542-5625
 Email Address: asantos-olivarez@fuscoe.com

KATHRINE CRUZ

AUG 31 2022

	F- 44633	F- 35764	F- 35765
Location:	SE Lexington Av / Vine St	NW Vine St / Lexington Av	SW Vine St / La Mirada Av
Distance from Nearest Pipe Location (feet):	16'	22'	22'
Hydrant Size:	2 1/2" x 4" DFH	4" D	4" D
Water Main Size (in):	8"	10"	10"
Static Pressure (psi):	118 max	118 max	120 max
Residual Pressure (psi):	90 psi	90 psi	92 psi
Flow at 20 psi (gpm):	1500 gpm	1500 gpm	1500 gpm

NOTE: Data obtained from hydraulic analysis using peak hour.

Remarks: Page 1 of 2 ECMR No. W20220901031

Please Include all Water Main Upsizing Requirements
 4 Public Fire Hydrants (1- S/W corner of La Mirada Ave, 1- N/E corner of Vine St/La Mirada Ave, 1- S/E corner of Vin
 St/Lexington Ave, 1- N/W corner of Vine St/Lexington Ave)
 High Density Residential and Neighborhood Commercial (Run Four Public Hydrants Simultaneously)

Water Purveyor: Los Angeles Department of Water & Power Date: 9/14/2022

Signature: Title: Civil Engineering Associate II

Requests must be made by submitting this completed application, along with a \$271 check payable to:
"Los Angeles Department of Water and Power", and mailed to:
 Los Angeles Department of Water and Power
 Distribution Engineering Section - Water
 Attn: Business Arrangements
 P.O. Box 51111 - Room 1425
 Los Angeles, CA 90051-5700

* If you have any questions, please contact us at (213) 367-2130 or visit our web site at <http://www.ladwp.com>.

Cynthia's



City of Los Angeles

Los Angeles Department of Water and Power - Water System

INFORMATION OF FIRE FLOW AVAILABILITY

Western

LAFD Fire Flow Requirement: 4,000 GPM (from 4 Hydrants) Water Service Map No.: 146-189
 LAFD Signature: _____
 Date Signed: _____

Applicant: Alejandra Santos
 Company Name: Fuscoe Engineering
 Address: 600 Wilshire Blvd, Suite 1470, Los Angeles, CA 90017
 Telephone: 213-542-5625
 Email Address: asantos-olivarez@fuscoe.com

	F- 42799	F- _____	F- _____
Location:	NE La Mirada Av / Vine St		
Distance from Nearest Pipe Location (feet):	27'		
Hydrant Size:	2 1/2" x 4" DFH		
Water Main Size (in):	6"		
Static Pressure (psi):	120 max		
Residual Pressure (psi):	92 psi		
Flow at 20 psi (gpm):	1500 gpm		

NOTE: Data obtained from hydraulic analysis using peak hour.

Remarks: Page 2 of 2 ECMR No. W20220901031

Please Include all Water Main Upsizing Requirements
4 Public Fire Hydrants (1- S/W corner of La Mirada Ave, 1- N/E corner of Vine St/La Mirada Ave, 1- S/E corner of Vine St/Lexington Ave, 1- N/W corner of Vine St/Lexington Ave)
High Density Residential and Neighborhood Commercial (Run Four Public Hydrants Simultaneously)

Water Purveyor: Los Angeles Department of Water & Power Date: 9/14/2022

Signature:  Title: Civil Engineering Associate II

Requests must be made by submitting this completed application, along with a \$271 check payable to: "Los Angeles Department of Water and Power", and mailed to:

**Los Angeles Department of Water and Power
 Distribution Engineering Section - Water
 Attn: Business Arrangements
 P.O. Box 51111 - Room 1425
 Los Angeles, CA 90051-5700**

* If you have any questions, please contact us at (213) 367-2130 or visit our web site at <http://www.ladwp.com>.

1200-1218 N. Vine St & 6245-6247 W. Lexington Ave

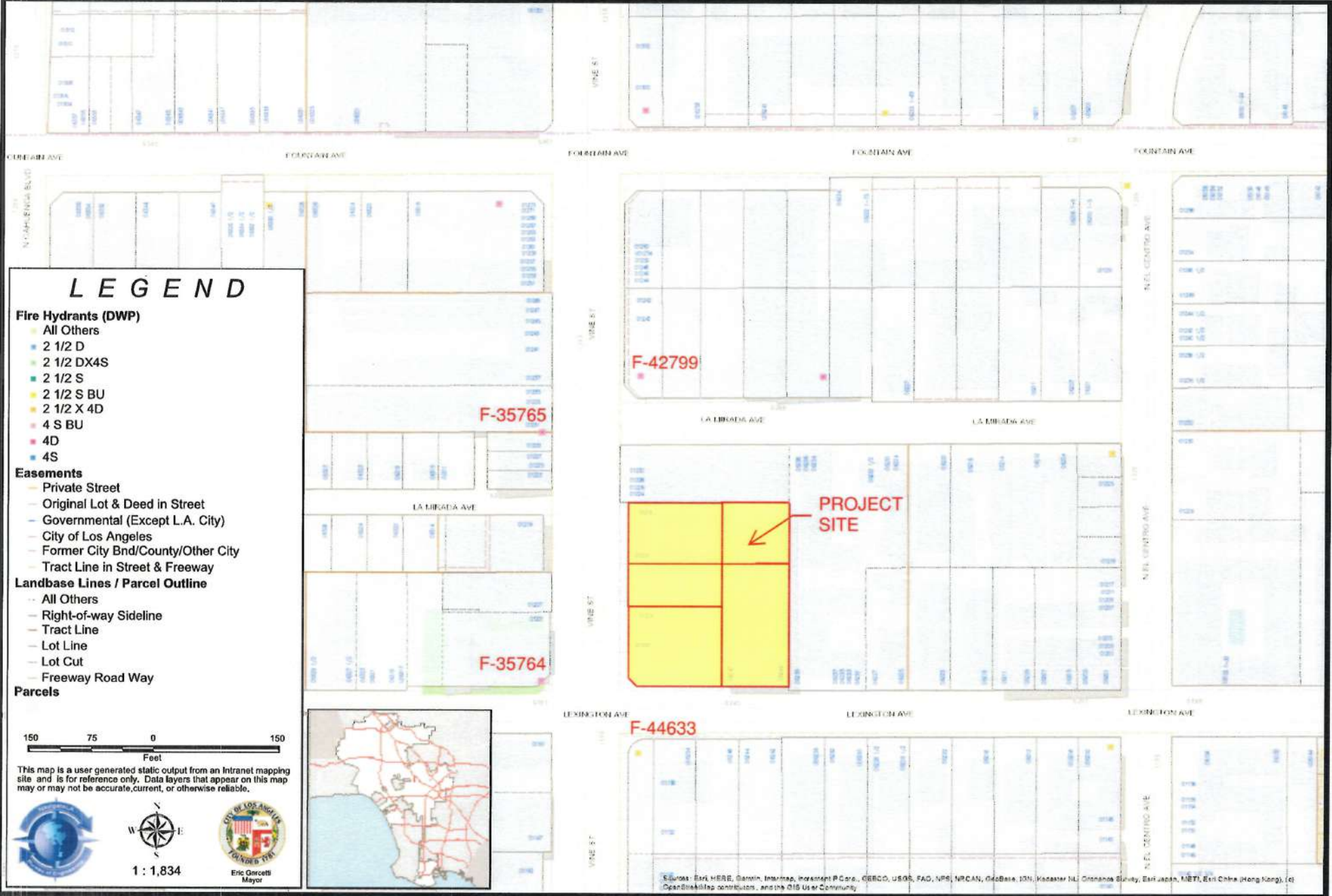

LEGEND

Fire Hydrants (DWP)

- All Others
- 2 1/2 D
- 2 1/2 DX4S
- 2 1/2 S
- 2 1/2 S BU
- 2 1/2 X 4D
- 4 S BU
- 4D
- 4S

Easements

- Private Street
- Original Lot & Deed in Street
- Governmental (Except L.A. City)
- City of Los Angeles
- Former City Bnd/County/Other City
- Tract Line in Street & Freeway

Landbase Lines / Parcel Outline

- All Others
- Right-of-way Sideline
- Tract Line
- Lot Line
- Lot Cut
- Freeway Road Way

Parcels



This map is a user generated static output from an Intranet mapping site and is for reference only. Data layers that appear on this map may or may not be accurate, current, or otherwise reliable.



1 : 1,834



Eric Garcetti
Mayor



© Sources: Esri, HERE, Garmin, Intermap, Inverness P Corp., GEBCO, USGS, FAO, NPS, NRCAN, GeoBase, IGN, Kadaster NL, Ordnance Survey, Esri Japan, METI, Esri China (Hong Kong), Swisstopo, Mapbox, and the GIS User Community

ATTACHMENT B

FIRE SERVICE PRESSURE FLOW REPORT (SAR)



City of Los Angeles
Los Angeles Department of Water and Power - Water System



SAR NUMBER 99815

Fire Service Pressure Flow Report

SERVICE NUMBER **640246**

For: 1200 VINE ST Approved Date: **9-16-2022**

Proposed Service 6 INCH off of the

10 inch main in VINE ST on the EAST side approximately

90 feet NORTH of NORTH of LEXINGTON AVE The System maximum pressure is

120 psi based on street curb elevation of 313 feet above sea level at this location.

The distance from the DWP street main to the property line is 68 feet

System maximum pressure should be used only for determining class of piping and fittings.

Residual Flow/Pressure Table for water system street main at this location

Flow (gpm)	Press. (psi)	Flow (gpm)	Press. (psi)	Flow (gpm)	Press. (psi)
0	90				
965	89				
1400	88				

Meter Assembly Capacities

Domestic Meters	
1 inch =	56 gpm
1-1/2 inch =	96 gpm
2 inch =	160 gpm
3 inch =	220 gpm
4 inch =	400 gpm
6 inch =	700 gpm
8 inch =	1500 gpm
10 inch =	2500 gpm

Fire Service	
2 inch =	250 gpm
4 inch =	600 gpm
6 inch =	1400 gpm
8 inch =	2500 gpm
10 inch =	5000 gpm

FM Services	
8 inch =	2500 gpm
10 inch =	5000 gpm

These values are subject to change due to changes in system facilities or demands.

Notes: With 700 gpm simultaneous domestic flow.

This information will be sent to the Department of Building and Safety for plan checking.
This SAR is valid for one year from 09-16-22. Once the SAR expires, the applicant needs to re-apply and pay applicable processing fee.
For additional information contact the Water Distribution Services Section **WESTERN (213) 367-1225**

MARK PATTERSON
Prepared by

MARK PATTERSON
Approved by

146-189
Water Service Map



City of Los Angeles

Los Angeles Department of Water and Power - Water System



SAR NUMBER 99816

Fire Service Pressure Flow ReportSERVICE NUMBER **640247**For: 1200 VINE ST Approved Date: **9-16-2022**Proposed Service 6 INCH off of the4 inch main in LEXINGTON AVE on the NORTH side approximately120 feet EAST of EAST of VINE ST The System maximum pressure is121 psi based on street curb elevation of 312 feet above sea level at this location.The distance from the DWP street main to the property line is 43 feet

System maximum pressure should be used only for determining class of piping and fittings.

Residual Flow/Pressure Table for water system street main at this location

Flow (gpm)	Press. (psi)	Flow (gpm)	Press. (psi)	Flow (gpm)	Press. (psi)
0	92	565	74		
120	91	585	73		
175	90	600	72		
215	89	615	71		
250	88	630	70		
285	87	650	69		
315	86	665	68		
340	85	680	67		
365	84	690	66		
390	83	705	65		
415	82	720	64		
435	81	735	63		
455	80	750	62		
475	79	760	61		
495	78	775	60		
515	77	785	59		
530	76	800	58		
550	75				

Meter Assembly Capacities

Domestic Meters	
1 inch =	56 gpm
1-1/2 inch =	96 gpm
2 inch =	160 gpm
3 inch =	220 gpm
4 inch =	400 gpm
6 inch =	700 gpm
8 inch =	1500 gpm
10 inch =	2500 gpm

Fire Service	
2 inch =	250 gpm
4 inch =	600 gpm
6 inch =	1400 gpm
8 inch =	2500 gpm
10 inch =	5000 gpm

FM Services	
8 inch =	2500 gpm
10 inch =	5000 gpm

These values are subject to change due to changes in system facilities or demands.

Notes: 800 gpm maximum flow from existing conditions. Requires upsize 160 feet of 4 inch pipe to 6 inch pipe to achieve 1400 gpm at this location.**This information will be sent to the Department of Building and Safety for plan checking.**

This SAR is valid for one year from 09-16-22. Once the SAR expires, the applicant needs to re-apply and pay applicable processing fee.

For additional information contact the Water Distribution Services Section **WESTERN (213) 367-1225****MARK PATTERSON**

Prepared by

MARK PATTERSON

Approved by

146-189

Water Service Map

ATTACHMENT C

WATER SERVICE WILL SERVE LETTER

August 29, 2022

Map No. 146-189

Ms. Alejandra Santos
Fusco Engineering
600 Wilshire Boulevard, Suite 1470
Los Angeles, CA 90017

Dear Ms. Santos:

Subject: Water Availability - Will Serve
1200-1218 North Vine Street & 6245-6247 West Lexington Avenue
APN 5534-002-023, 5534-002-018 Colegrove Tract, Lot FR (Arb 3,4.5.6 and 8)

This is in reply to your request regarding water availability for the above-mentioned location. This property can be supplied with water from the municipal system subject to the Water System rules of the Los Angeles Department of Water and Power (LADWP). It is also subject to all conditions set by LADWP.

Should you require additional information, please contact Ms. Stella Kim at (213) 367-0247. Correspondence may be addressed to:

LADWP
111 North Hope Street, Room 1425
Los Angeles, California 90012

Sincerely,

fgonzalez
Liz Gonzalez
Manager-Business Arrangements
Water Distribution Engineering

SK:kc
c: Ms. Stella Kim

ATTACHMENT D

CITY OF LOS ANGELES, LABOS – WILL SERVE LETTER

**BOARD OF PUBLIC WORKS
MEMBERS**

AURA GARCIA
PRESIDENT

M. TERESA VILLEGAS
VICE PRESIDENT

DR. MICHAEL R. DAVIS
PRESIDENT PRO TEMPORE

VAHID KHORSAND
COMMISSIONER

SUSANA REYES
COMMISSIONER

DR. FERNANDO CAMPOS
EXECUTIVE OFFICER

**CITY OF LOS ANGELES
CALIFORNIA**



ERIC GARCETTI
MAYOR

**DEPARTMENT OF
PUBLIC WORKS**

**BUREAU OF
ENGINEERING**

TED ALLEN, PE
CITY ENGINEER

1149 S BROADWAY, SUITE 700
LOS ANGELES, CA 90015-2213

<http://eng.lacity.org>

11/08/2022

ALEJANDRA SANTOS
600 W WILSHIRE BLVD, SUITE 1470
LOS ANGELES, CA, 90017

Dear ALEJANDRA SANTOS,

SEWER AVAILABILITY: 1200-1218 N VINE ST / 6245-6247 W LEXINGTON AVE

The Bureau of Sanitation has reviewed your request of 10/27/2022 for sewer availability at **1200-1218 N VINE ST / 6245-6247 W LEXINGTON AVE**. Based on their analysis, it has been determined on 11/08/2022 that there is capacity available to handle the anticipated discharge from your proposed project(s) as indicated in the attached copy of the Sewer Capacity Availability Request (SCAR) .

This determination is valid for 180 days from the date shown on the Sewer Capacity Availability request (SCAR) approved by the Bureau of Sanitation.

While there is hydraulic capacity available in the local sewer system at this time, availability of sewer treatment capacity will be determined at the Bureau of Engineering Public Counter upon presentation of this letter. A Sewer Connection Permit may also be obtained at the same counter provided treatment capacity is available at the time of application.

A Sewerage Facilities Charge is due on all new buildings constructed within the City. The amount of this charge will be determined when application is made for your building permit and the Bureau of Engineering has the opportunity to review the building plans. To facilitate this determination a preliminary set of plans should be submitted to Bureau of Engineering District Office, Public Counter.

Provision for a clean out structure and/or a sewer trap satisfactory to the Department of Building and Safety may be required as part of the sewer connection permit.

Lateral connection of development shall adhere to Bureau of Engineering Sewer Design Manual Section F 480. **If not listed in the Proposed Facility Description section of the SCAR, sewer ejector use is prohibited.**

Sincerely,

Steve Melgar
CE ASSOCIATE
Central District, Bureau of Engineering

City of Los Angeles
Bureau of Engineering

SEWER CAPACITY AVAILABILITY REVIEW FEE (SCARF) - Frequently Asked Questions

SCAR stands for Sewer Capacity Availability Review that is performed by the Department of Public Works, Bureau of Sanitation. This review evaluates the existing sewer system to determine if there is adequate capacity to safely convey sewage from proposed development projects, proposed construction projects, proposed groundwater dewatering projects and proposed increases of sewage from existing facilities. The SCAR Fee (SCARF) recovers the cost, incurred by the City, in performing the review for any SCAR request that is expected to generate 10,000 gallons per day (gpd) of sewage.

The SCARF is based on the effort required to perform data collection and engineering analysis in completing a SCAR. A brief summary of that effort includes, but is not limited to, the following:

1. Research and trace sewer flow levels upstream and downstream of the point of connection.
2. Conduct field surveys to observe and record flow levels. Coordinate with maintenance staff to inspect sewer maintenance holes and conduct smoke and dye testing if necessary.
3. Review recent gauging data and in some cases closed circuit TV inspection (CCTV) videos.
4. Perform gauging and CCTV inspection if recent data is not available.
5. Research the project location area for other recently approved SCARs to evaluate the cumulated impact of all known SCARs on the sewer system.
6. Calculate the impact of the proposed additional sewage discharge on the existing sewer system as it will be impacted from the approved SCARs from Item 6 above. This includes tracing the cumulative impacts of all known SCARs, along with the subject SCAR, downstream to insure sufficient capacity exist throughout the system.
7. Correspond with the applicant for additional information and project and clarification as necessary.
8. Work with the applicant to find alternative sewer connection points and solutions if sufficient capacity does not exist at the desired point of connection.

Questions and Answers:

1. When is the SCARF applied, or charged?

It applies to all applicants seeking a Sewer Capacity Availability Review (SCAR). SCARs are generally required for Sewer Facility Certificate applications exceeding 10,000 gpd, or request from a property owner seeking to increase their discharge thru their existing connection by 10,000 gpd or more, or any groundwater related project that discharges 10,000 gpd or more, or any proposed or future development for a project that could result in a discharge of 10,000 gpd.

2. Why is the SCARF being charged now when it has not been in the past?

The City has seen a dramatic increase in the number of SCARs over 10,000 gpd in the last few years and has needed to increase its resources, i.e., staff and gauging efforts, to respond to them. The funds collected thru SCARF will help the City pay for these additional resources and will be paid by developers and property owners that receive the benefit from the SCAR effort.

3. Where does the SCARF get paid?

The Department of Public Works, Bureau of Engineering (BOE) collects the fee at its public counters. Once the fee is paid then BOE prepares a SCAR request and forwards it to the BOS where it is reviewed and then returned to BOE. BOE then informs the applicant of the result. In some cases, BOS works directly with the applicant during the review of the SCAR to seek additional information and work out alternative solutions

ATTACHMENT E

SEWER CAPACITY AVAILABILITY REPORT (SCAR)

Sewer Capacity Availability Request (SCAR)

To: Bureau of Sanitation

The following request is submitted to you on behalf of the applicant requesting to connect to the public sewer system. Please verify that the capacity exists at the requested location for the proposed developments shown below. The results are good for 180 days from the date the sewer capacity approval from the Bureau of Sanitation. Lateral connection of development shall adhere to Bureau of Engineering Sewer Design Manual Section F 480. **If not listed in the Proposed Facility Description section of the SCAR, sewer ejector use is prohibited.**

Job Address:	1200-1218 N VINE ST / 6245-6247 W LEXINGTON AVE	Sanitation Scar ID:	70-6342-1122
Date Submitted	10/27/2022	Request Will Serve Letter?	Yes
BOE District:	Central District		
Applicant:	ALEJANDRA SANTOS		
Address:	600 W WILSHIRE BLVD, SUITE 1470	City :	LOS ANGELES
State:	CA	Zip:	90017
Phone:	213-542-5621	Fax:	
Email:	ASANTOS-OLIVAREZ@FUSCOE.COM	BPA No.	
S-Map:	493	Wye Map:	4669-2

SIMM Map - Maintenance Hole Locations

No.	Street Name	U/S MH	D/S MH	Diam. (in)	Approved Flow %	Notes
1	LEXINGTON AVE	49302155	49302039	12	50.00	26,610 GPD
2	VINE ST	49302023	49302040	10	50.00	26,610 GPD

Proposed Facility Description

No.	Proposed Use Description	Sewage Generation (GPD)	Unit	Qty	GPD
1	RESIDENTIAL: APT - BACHELOR	75	DU	21	1,575
2	RESIDENTIAL: APT - 1 BDRM. *6	110	DU	89	9,790
3	RESIDENTIAL: APT - 2 BDRMS *6	150	DU	43	6,450
4	SWIMMING POOL (RESIDENTIAL WITH REPLACEABLE FILTER CARTRIDGES)		GPD	29,330	29,330
5	GYMNASIUM - BASKETBALL, VOLLEYBALL *10	200	KGSF	1,000	200
6	RESTAURANT: FAST FOOD INDOOR SEAT	25	SEAT	235	5,875

Proposed Total Flow (gpd): 53,220

Remarks 1): Approved for the maximum allowable capacity of 53,220 GPD (36.96 gpm). 2): This SCAR will supersede previous SCAR IDs # 69-6230-0822. 3): Discharge as indicated in flow %s. 4): IWMD Permit required.

Note: Results are good for 180 days from the date of approval by the Bureau of Sanitation

Date Processed: **11/08/2022** Expires On: **05/07/2023**

Processed by: **Albert Lew**
Bureau of Sanitation
Phone: 323-342-6207
Sanitation Status: **Approved**
Reviewed by: **Sunbula Azieh**
on **11/07/2022**

Submitted by: **Steve Melgar**
Bureau of Engineering
Central District
Phone:

Fees Collected	Yes	SCAR FEE (W:37 / QC:705) \$1,996.50
Date Collected	11/03/2022	SCAR Status: Completed

SEWER CAPACITY AVAILABILITY REVIEW FEE (SCARF) - Frequently Asked Questions

SCAR stands for Sewer Capacity Availability Review that is performed by the Department of Public Works, Bureau of Sanitation. This review evaluates the existing sewer system to determine if there is adequate capacity to safely convey sewage from proposed development projects, proposed construction projects, proposed groundwater dewatering projects and proposed increases of sewage from existing facilities. The SCAR Fee (SCARF) recovers the cost, incurred by the City, in performing the review for any SCAR request that is expected to generate 10,000 gallons per day (gpd) of sewage.

The SCARF is based on the effort required to perform data collection and engineering analysis in completing a SCAR. A brief summary of that effort includes, but is not limited to, the following:

1. Research and trace sewer flow levels upstream and downstream of the point of connection.
2. Conduct field surveys to observe and record flow levels. Coordinate with maintenance staff to inspect sewer maintenance holes and conduct smoke and dye testing if necessary.
3. Review recent gauging data and in some cases closed circuit TV inspection (CCTV) videos.
4. Perform gauging and CCTV inspection if recent data is not available.
5. Research the project location area for other recently approved SCARs to evaluate the cumulated impact of all known SCARs on the sewer system.
6. Calculate the impact of the proposed additional sewage discharge on the existing sewer system as it will be impacted from the approved SCARs from Item 6 above. This includes tracing the cumulative impacts of all known SCARs, along with the subject SCAR, downstream to insure sufficient capacity exist throughout the system.
7. Correspond with the applicant for additional information and project and clarification as necessary.
8. Work with the applicant to find alternative sewer connection points and solutions if sufficient capacity does not exist at the desired point of connection.

Questions and Answers:

1. When is the SCARF applied, or charged?

It applies to all applicants seeking a Sewer Capacity Availability Review (SCAR). SCARs are generally required for Sewer Facility Certificate applications exceeding 10,000 gpd, or request from a property owner seeking to increase their discharge thru their existing connection by 10,000 gpd or more, or any groundwater related project that discharges 10,000 gpd or more, or any proposed or future development for a project that could result in a discharge of 10,000 gpd.

2. Why is the SCARF being charged now when it has not been in the past?

The City has seen a dramatic increase in the number of SCARs over 10,000 gpd in the last few years and has needed to increase its resources, i.e., staff and gauging efforts, to respond to them. The funds collected thru SCARF will help the City pay for these additional resources and will be paid by developers and property owners that receive the benefit from the SCAR effort.

3. Where does the SCARF get paid?

The Department of Public Works, Bureau of Engineering (BOE) collects the fee at its public counters. Once the fee is paid then BOE prepares a SCAR request and forwards it to the BOS where it is reviewed and then returned to BOE. BOE then informs the applicant of the result. In some cases, BOS works directly with the applicant during the review of the SCAR to seek additional information and work out alternative solutions

Geotechnologies, Inc.

Consulting Geotechnical Engineers

439 Western Avenue
Glendale, California 91201-2837
818.240.9600 • Fax 818.240.9675



December 9, 2021
File Number 22207

Grubb Properties
4601 Park Road, Suite 450
Charlotte, North Carolina 28209

Attention: Charlie Rulick

Subject: Geotechnical Engineering Investigation
Proposed Mixed-Use Development
1200 through 1218 North Vine Street, 6245 and 6247 West Lexington Avenue
Los Angeles, California

Dear Mr. Rulick:

This letter transmits the Geotechnical Engineering Investigation for the subject site prepared by Geotechnologies, Inc. This report provides geotechnical recommendations for the development of the site, including earthwork, seismic design, retaining walls, excavations, shoring and foundation design. Engineering for the proposed project should not begin until approval of the geotechnical investigation is granted by the local building official. Significant changes in the geotechnical recommendations may result due to the building department review process.

The validity of the recommendations presented herein is dependent upon review of the geotechnical aspects of the project during construction by this firm. The subsurface conditions described herein have been projected from limited subsurface exploration and laboratory testing. The exploration and testing presented in this report should in no way be construed to reflect any variations which may occur between the exploration locations or which may result from changes in subsurface conditions.

Should you have any questions please contact this office.

Respectfully submitted,
GEOTECHNOLOGIES, INC.

GREGORIO VARELA
R.C.E. 81201



GV:ln

Distribution: (3) Saiko Investment Corp.; Attn: Fred Schaffer

Email to: [fshaffer@gtocompanies.com]

TABLE OF CONTENTS

<u>SECTION</u>	<u>PAGE</u>
INTRODUCTION	1
PROPOSED DEVELOPMENT.....	1
SITE CONDITIONS.....	2
GEOTECHNICAL EXPLORATION.....	3
FIELD EXPLORATION	3
Geologic Materials.....	3
Groundwater	4
Caving.....	4
SEISMIC EVALUATION.....	4
REGIONAL GEOLOGIC SETTING.....	4
REGIONAL FAULTING.....	5
SEISMIC HAZARDS AND DESIGN CONSIDERATIONS.....	6
Surface Rupture	6
Liquefaction	7
Dynamic Dry Settlement.....	9
Tsunamis, Seiches and Flooding.....	9
Landsliding	9
CONCLUSIONS AND RECOMMENDATIONS	10
SEISMIC DESIGN CONSIDERATIONS	11
California Building Code Seismic Parameters	11
EXPANSIVE SOILS	12
SOIL CORROSION POTENTIAL.....	13
METHANE ZONES	13
GRADING GUIDELINES	14
Site Preparation.....	14
Recommended Overexcavation and Blending.....	14
Compaction.....	15
Acceptable Materials	15
Utility Trench Backfill.....	16
Wet Soils.....	16
Shrinkage	17
Weather Related Grading Considerations.....	17
Abandoned Seepage Pits.....	18
Geotechnical Observations and Testing During Grading.....	19
LEED Considerations	19
FOUNDATION DESIGN.....	20
Conventional.....	20
Foundation Reinforcement.....	21
Lateral Design.....	21
Foundation Settlement	22
Foundation Observations	22
RETAINING WALL DESIGN.....	23
Cantilever Retaining Walls.....	23



TABLE OF CONTENTS

SECTION	PAGE
Restrained Retaining Walls.....	24
Dynamic (Seismic) Earth Pressure	24
Surcharge from Adjacent Structures	25
Retaining Wall Drainage.....	25
Sump Pump Design.....	26
Waterproofing	27
Retaining Wall Backfill	27
TEMPORARY EXCAVATIONS	28
Slot Cutting.....	29
Trench Shoring.....	29
SHORING DESIGN	30
Soldier Piles	30
Lagging	32
Lateral Pressures	32
Deflection.....	32
Monitoring	33
Shoring Observations.....	33
SLABS ON GRADE.....	33
Concrete Slabs-on Grade	33
Design of Slabs That Receive Moisture-Sensitive Floor Coverings	34
Concrete Crack Control	35
Slab Reinforcing	36
PAVEMENTS.....	36
SITE DRAINAGE	37
STORMWATER DISPOSAL	38
DESIGN REVIEW	39
CONSTRUCTION MONITORING.....	39
EXCAVATION CHARACTERISTICS.....	40
CLOSURE AND LIMITATIONS.....	41
EXCLUSIONS.....	42
GEOTECHNICAL TESTING.....	42
Classification and Sampling	42
Moisture and Density Relationships	43
Direct Shear Testing	43
Consolidation Testing.....	44
Expansion Index Testing.....	44
Laboratory Compaction Characteristics	45
Grain Size Distribution	45
Atterberg Limits.....	45



TABLE OF CONTENTS

<u>SECTION</u>	<u>PAGE</u>
ENCLOSURES	
References	
Vicinity Map	
Plot Plan	
Local Geologic Map	
Historically Highest Groundwater Levels Map	
Earthquake Zones of Required Investigation Map	
Plates A-1 and A-2	
Plates B-1 and B-2	
Plates C-1 through C-3	
Plate D	
Plate E	
Plate F	
Calculation Sheets (9 pages)	
Soil Corrosivity Study by Project X (31 pages)	



**GEOTECHNICAL ENGINEERING INVESTIGATION
PROPOSED MIXED-USE DEVELOPMENT
1200 THROUGH 1218 NORTH VINE STREET,
6245 AND 6247 WEST LEXINGTON AVENUE
LOS ANGELES, CALIFORNIA**

INTRODUCTION

This report presents the results of the geotechnical engineering investigation performed on the subject site. The purpose of this investigation was to identify the distribution and engineering properties of the geologic materials underlying the site, and to provide geotechnical recommendations for the design of the proposed development.

This investigation included two exploratory excavations, collection of representative samples, laboratory testing, engineering analysis, review of published geologic data, review of available geotechnical engineering information and the preparation of this report. The exploratory excavation locations are shown on the enclosed Plot Plan. The results of the exploration and the laboratory testing are presented in the Appendix of this report.

PROPOSED DEVELOPMENT

Information concerning the proposed development was obtained by review of the Conceptual Plans prepared by KTGy, dated October 11, 2021. The proposed development consists of construction of an eight story mixed-use structure, to be built at- or near the existing site grade. The first two levels will consist of parking and retail space, while the remaining levels will consist of residential space. The location and alignment of the proposed structure is shown on the enclosed Plot Plan.



Structural information is not available at this time. Wall loads are estimated to range between 4 and 12 kips per lineal foot. Column loads are estimated to range between 300 and 700 kips. Grading is expected to consist of excavations on the order of 5 to 7 feet for the removal and recompaction of existing unsuitable soils.

Any changes in the design of the project or location of any structure, as outlined in this report, should be reviewed by this office. The recommendations contained in this report should not be considered valid until reviewed and modified or reaffirmed, in writing, subsequent to such review.

SITE CONDITIONS

The site is located at 1200 through 1218 North Vine Street, and 6245 and 6247 West Lexington Avenue, in the Hollywood area of the City of Los Angeles, California. The site is rectangular in shape, and just under one acre in area. The site is bounded by a two-story office building to the north, two apartment buildings to the east, Lexington Avenue to the south, and North Vine Street to the west. The site is shown relative to nearby topographic features in the enclosed Vicinity Map.

The apartment buildings located to the east of the subject site are two and three stories in height. One of the buildings was built at-grade, while the other was built over a partially-subterranean parking garage. As shown in the enclosed Plot Plan, the building with the partially-subterranean garage is setback from the property line, therefore it is not anticipated that the new structure will surcharge the adjacent subterranean retaining walls.

Based on review of the Land Title Survey prepared by LG Land Surveying, Inc., dated October 13, 2020, the site grade descends gently to the southwest. The elevation relief observed across the site is in the order of 3 feet. The site is currently developed with two single-story commercial structures, and a paved parking lot. Vegetation at the site is limited, and consists of a few mature palm trees, as well as shrubbery contained in small planter areas. Drainage across the site appears to be by sheetflow to the city streets to the southwest.



GEOTECHNICAL EXPLORATION

FIELD EXPLORATION

The site was explored on October 25, 2021 by drilling two borings. The borings were drilled to a depth of 30 and 50 feet below the existing grade, with the aid of a truck-mounted drilling machine using 8-inch diameter hollowstem augers. The exploration locations are shown on the Plot Plan and the geologic materials encountered are logged on Plates A-1 and A-2.

The location of exploratory excavations was determined from hardscaped features shown in the enclosed Plot Plan. Elevations of the exploratory excavations were approximated from elevation provided in the Land Title Survey prepared by LG Land Surveying, Inc., dated October 13, 2020. The location and elevation of the exploratory excavations should be considered accurate only to the degree implied by the method used.

Geologic Materials

Fill materials were encountered in both exploratory borings, to an approximate depth of 3 feet below the existing grade. The fill consist of sandy to clayey silt, and is dark brown in color, moist and stiff.

The fill is in turn underlain by native older alluvial soils, consisting of interlayered mixtures of sand, silt and clay. The alluvial soils are yellowish brown to dark brown in color, moist to wet, medium dense to very dense, or stiff, and fine to medium grained. More detailed descriptions of the earth materials encountered may be obtained from individual logs of the subsurface excavations.



Groundwater

Groundwater was encountered in both exploratory borings, at depths of 20 and 21½ feet below the existing grade. The historically highest groundwater level was established by review of the California Geological Survey Seismic Hazard Evaluation Report 026 Plate 1.2 entitled “Historically Highest Ground Water Contours”. Review of this plate indicates that the historically highest groundwater level is on the order of 37 feet below grade. A copy of this plate is included in the Appendix as Historically Highest Groundwater Levels Map.

Fluctuations in the level of groundwater may occur due to variations in rainfall, temperature, and other factors not evident at the time of the measurements reported herein. Fluctuations also may occur across the site. High groundwater levels can result in changed conditions.

Caving

Caving could not be directly observed during exploration due to the type of excavation equipment utilized. However, based on the experience of this firm, large diameter excavations, excavations that encounter granular, cohesionless soils and excavations below the groundwater could potentially experience caving.

SEISMIC EVALUATION

REGIONAL GEOLOGIC SETTING

The subject site is located in the Los Angeles Basin of the northern portion of the Peninsular Ranges Geomorphic Province. The Peninsular Ranges are characterized by northwest-trending blocks of mountain ridges and sediment-floored valleys. The dominant geologic structural features are northwest trending fault zones that either die out to the northwest or terminate at east-trending reverse faults that form the southern margin of the Transverse Ranges.



The Los Angeles Basin is located at the northern end of the Peninsular Ranges Geomorphic Province. The basin is bounded by the east and southeast by the Santa Ana Mountains and San Joaquin Hills, to the northwest by the Santa Monica Mountains. Over 22 million years ago the Los Angeles basin was a deep marine basin formed by tectonic forces between the North American and Pacific plates. Since that time, over 5 miles of marine and non-marine sedimentary rock as well as intrusive and extrusive igneous rocks have filled the basin. During the last 2 million years, defined by the Pleistocene and Holocene epochs, the Los Angeles basin and surrounding mountain ranges have been uplifted to form the present day landscape. Erosion of the surrounding mountains has resulted in deposition of unconsolidated sediments in low-lying areas by rivers such as the Los Angeles River. Areas that have experienced subtle uplift have been eroded with gullies.

REGIONAL FAULTING

Based on criteria established by the California Division of Mines and Geology (CDMG) now called California Geologic Survey (CGS), Faults may be categorized as Holocene-active, Pre-Holocene faults, and Age-undetermined faults. Holocene-active faults are those which show evidence of surface displacement within the last 11,700 years. Pre-Holocene faults are those that have not moved in the past 11,700 years. Age-undetermined faults are faults where the recency of fault movement has not been determined.

Buried thrust faults are faults without a surface expression but are a significant source of seismic activity. They are typically broadly defined based on the analysis of seismic wave recordings of hundreds of small and large earthquakes in the southern California area. Due to the buried nature of these thrust faults, their existence is usually not known until they produce an earthquake. The risk for surface rupture potential of these buried thrust faults is inferred to be low (Leighton, 1990). However, the seismic risk of these buried structures in terms of recurrence and maximum potential magnitude is not well established. Therefore, the potential for surface rupture on these surface-verging splays at magnitudes higher than 6.0 cannot be precluded.



SEISMIC HAZARDS AND DESIGN CONSIDERATIONS

The primary geologic hazard at the site is moderate to strong ground motion (acceleration) caused by an earthquake on any of the local or regional faults. The potential for other earthquake-induced hazards was also evaluated including surface rupture, liquefaction, dynamic settlement, inundation and landsliding.

Surface Rupture

In 1972, the Alquist-Priolo Special Studies Zones Act (now known as the Alquist-Priolo Earthquake Fault Zoning Act) was passed into law. As revised in 2018, The Act defines “Holocene-active” Faults utilizing the same aging criteria as that used by California Geological Survey (CGS). However, established state policy has been to zone only those faults which have direct evidence of movement within the last 11,700 years. It is this recency of fault movement that the CGS considers as a characteristic for faults that have a relatively high potential for ground rupture in the future.

CGS policy is to delineate a boundary from 200 to 500 feet wide on each side of the Holocene-Active fault trace based on the location precision, the complexity, or the regional significance of the fault. If a site lies within an Earthquake Fault Zone, a geologic fault rupture investigation must be performed that demonstrates that the proposed building site is not threatened by surface displacement from the fault before development permits may be issued.

Review of the Earthquake Zones of Required Investigation Map of the Hollywood Quadrangle (CGS, 2014) indicates that the subject site is not located within an Alquist-Priolo Earthquake Fault Zone. The closest zone is the Hollywood Fault Zone, which is located just over half-mile to the north of the subject site. A copy of this map is enclosed herein.



Ground rupture is defined as surface displacement which occurs along the surface trace of the causative fault during an earthquake. Based on research of available literature and results of site reconnaissance, no known active or potentially active faults underlie the subject site. In addition, the subject site is not located within an Alquist-Priolo Earthquake Fault Zone. Based on these considerations, the potential for surface ground rupture at the subject site is considered low.

Liquefaction

Liquefaction is a phenomenon in which saturated silty to cohesionless soils below the groundwater table are subject to a temporary loss of strength due to the buildup of excess pore pressure during cyclic loading conditions such as those induced by an earthquake. Liquefaction-related effects include loss of bearing strength, amplified ground oscillations, lateral spreading, and flow failures.

As shown in the enclosed Earthquake Zones of Required Investigation Map, the State of California does not classify the site as part of a Liquefiable area. This determination is based on groundwater depth records, soil type and distance to a fault capable of producing a substantial earthquake.

As a conservative measure, a site-specific liquefaction analysis was performed following the Recommended Procedures for Implementation of the California Geologic Survey Special Publication 117A, Guidelines for Analyzing and Mitigating Seismic Hazards in California (CGS, 2008), and the EERI Monograph (MNO-12) by Idriss and Boulanger (2008). This semi-empirical method is based on a correlation between measured values of Standard Penetration Test (SPT) resistance and field performance data.

Groundwater was encountered during exploration, at a depth of 20 and 21½ feet below the existing grade. Based on review of the seismic hazard zone report of the Hollywood 7½-minute quadrangle (CDMG, 2006), the historically highest groundwater level for the site was 37 feet below the ground surface. The enclosed liquefaction analysis is based on a groundwater level of 20 feet.



Section 11.8.3 of ASCE 7-16 indicates that the potential for liquefaction shall be evaluated utilizing an acceleration consistent with the MCE_G PGA. Utilizing the OSHPD seismic utility program, this corresponds to a PGA_M of 0.99g. The USGS Probabilistic Seismic Hazard Deaggregation program (USGS, 2014) indicates a PGA of 0.91g (2 percent in 50 years ground motion) and a mean magnitude of 6.8 for the site. The liquefaction potential evaluation was performed by utilizing a magnitude 6.8 earthquake, and a peak horizontal acceleration of 0.99g.

The enclosed “Empirical Estimation of Liquefaction Potential” is based on Boring 1. Standard Penetration Test (SPT) data were collected at 5-foot intervals. Samples of the collected materials were conveyed to the laboratory for testing and analysis. The percent passing a Number 200 sieve, Atterberg Limits, and the plasticity index (PI) of representative samples of the soils encountered in the exploratory borings are presented on the enclosed E-Plate and F-Plate.

Based on CGS Special Publication 117A (CDMG, 2008) and (Bray and Sancio, 2006), the vast majority of liquefaction hazards are associated with sandy soils and silty soils of low plasticity. Furthermore, soils having a PI greater than 18 exhibit clay-like behavior, and the liquefaction potential of these soils are considered to be low. The results of Atterberg Limits testing (shown on Plate F) indicate that some of soil layers below the subject site have PI greater than 18. Therefore, these soils are not considered prone to liquefaction, and the analysis of these soil layers was turned off in the liquefaction susceptibility columns.

The site-specific liquefaction analysis included in the Appendix, indicates that the site soils would not be prone to liquefaction during the ground motion expected during the design-based seismic event.



Dynamic Dry Settlement

Seismically-induced settlement or compaction of dry or moist, cohesionless soils can be an effect related to earthquake ground motion. Such settlements are typically most damaging when the settlements are differential in nature across the length of structures.

Some seismically-induced settlement of the proposed structures should be expected as a result of strong ground-shaking, however, due to the uniform nature of the underlying geologic materials, excessive differential settlements are not expected to occur.

Tsunamis, Seiches and Flooding

Tsunamis are large ocean waves generated by sudden water displacement caused by a submarine earthquake, landslide, or volcanic eruption. Review of the County of Los Angeles Flood and Inundation Hazards Map (Leighton, 1990) indicates the site does not lie within mapped tsunami inundation boundaries.

Review of the County of Los Angeles Flood and Inundation Hazards Map, (Leighton, 1990), indicates the site lies within the mapped inundation boundaries of the Mulholland Dam. A determination of whether a higher site elevation would remove the site from the potential inundation zones is beyond the scope of this assessment.

Landsliding

The probability of seismically-induced landslides occurring on the site is considered to be low due to the general lack of elevation difference across or adjacent to the site.



CONCLUSIONS AND RECOMMENDATIONS

Based upon the exploration, laboratory testing, and research, it is the finding of Geotechnologies, Inc. that construction of the proposed mixed-use structure is considered feasible from a geotechnical engineering standpoint provided the advice and recommendations presented herein are followed and implemented during construction.

During exploration, fill materials were observed to extend to a depth of 3 feet below the existing grade. The existing fill materials are considered to be unsuitable for support of foundations, floor slabs, or additional fill. However, the existing fill materials may be reused in the preparation of a compacted fill pad.

The reported fill depth was recorded at two discrete locations. Deeper fill materials may be encountered within other areas, including the portion of the site currently occupied by the existing structures. It is recommended that supplemental potholing be conducted around the perimeter of the site prior to construction. This would provide a better understanding of the fill distribution across the site, and help select a suitable temporary stabilization measure for temporary excavations which will be conducted adjacent to the property line.

The proposed structure may be supported on conventional foundations bearing in a newly placed uniform compacted fill pad. For the construction of a uniform compacted fill pad, all existing fill materials and upper alluvial soils shall be removed and recompacted to a minimum depth of 5 feet below the proposed grade, or of 3 feet below the bottom of the proposed foundations, whichever is deeper. In addition, the compacted fill should extend horizontally a minimum of 3 feet beyond the edge of foundations, or for a distance equal to the depth of fill below the foundation, whichever is greater.



Construction of a proper compacted fill pad may not be possible along portions of the perimeter, where the proposed structure will be built adjacent to the property lines, and the recommended compacted fill pad horizontal over-excavation may not be achievable. In areas where the horizontal over-excavation will not be possible, the proposed foundations should be deepened to bear in undisturbed alluvial soils.

The validity of the conclusions and design recommendations presented herein is dependent upon review of the geotechnical aspects of the proposed construction by this firm. The subsurface conditions described herein have been projected from excavations on the site as indicated and should in no way be construed to reflect any variations which may occur between these excavations or which may result from changes in subsurface conditions. Any changes in the design, as outlined in this report, should be reviewed by this office. The recommendations contained herein should not be considered valid until reviewed and modified or reaffirmed subsequent to such review.

SEISMIC DESIGN CONSIDERATIONS

California Building Code Seismic Parameters

Based on information derived from the subsurface investigation, the subject site is classified as Site Class D, which corresponds to a “Stiff Soil” Profile, according to Table 20.3-1 of ASCE 7-16. This information and the site coordinates were input into the OSHPD seismic utility program in order to calculate ground motion parameters for the site.



CALIFORNIA BUILDING CODE SEISMIC PARAMETERS	
California Building Code	2019
ASCE Design Standard	7-16
Site Class	D
Mapped Spectral Acceleration at Short Periods (S_S)	2.096g
Site Coefficient (F_a)	1.0
Maximum Considered Earthquake Spectral Response for Short Periods (S_{MS})	2.096g
Five-Percent Damped Design Spectral Response Acceleration at Short Periods (S_{DS})	1.397g
Mapped Spectral Acceleration at One-Second Period (S_1)	0.750g
Site Coefficient (F_v)	1.7*
Maximum Considered Earthquake Spectral Response for One-Second Period (S_{M1})	1.275g*
Five-Percent Damped Design Spectral Response Acceleration for One-Second Period (S_{D1})	0.850g*

* According to ASCE 7-16, a Long Period Site Coefficient (F_v) of 1.7 may be utilized provided that the value of the Seismic Response Coefficient (C_s) is determined by Equation 12.8-2 for values of $T \leq 1.5T_s$ and taken as equal to 1.5 times the value computed in accordance with either Equation 12.8-3 for $T_L \geq T > 1.5T_s$ or equation 12.8-4 for $T > T_L$. Alternatively, a site-specific ground motion hazard analysis may be performed in accordance with ASCE 7-16 Section 21.1 and/or a ground motion hazard analysis in accordance with ASCE 7-16 Section 21.2 to determine ground motions for any structure.

EXPANSIVE SOILS

The onsite geologic materials are in the high expansion range. The Expansion Index was found to be 94 and 106 for a representative bulk samples. Recommended reinforcing is provided in the “Foundation Design” and “Slab-On-Grade” sections of this report.



SOIL CORROSION POTENTIAL

The results of the soil corrosivity testing performed on two samples representative of the onsite soils by Project X Corrosion Engineering indicate that the electrical resistivities of the soils are moderately corrosive to general metals when saturated. The soil pH value of the samples was between 8.0 and 8.1. This pH level is not detrimental to copper and aluminum alloys, but can allow corrosion of steel and iron in moist environments. Chloride levels in the samples are low and may cause insignificant corrosion of metals. Ammonia and Nitrates concentrations were not high enough to cause accelerated corrosion of copper and copper alloys, such as brass.

Sulfate content in the samples are considered negligible for corrosion of metals and cement. Special cement types need not be utilized for concrete structures in contact with the soils, since the sulfate content of the soils is negligible.

Detailed results, discussion of results and recommended mitigating measures are provided within the enclosed Corrosion Evaluation Report prepared by Project X Corrosion Engineering, dated December 7, 2021.

METHANE ZONES

This office has reviewed the City of Los Angeles Methane and Methane Buffer Zones map. Based on this review it appears that the subject property is not located within a Methane Zone or a Methane Buffer Zone, as designated by the City.



GRADING GUIDELINES

Site Preparation

- A thorough search should be made for possible underground utilities and/or structures. Any existing or abandoned utilities or structures located within the footprint of the proposed grading should be removed or relocated as appropriate.
- All vegetation, existing fill, and soft or disturbed geologic materials should be removed from the areas to receive controlled fill. All existing fill materials and any disturbed geologic materials resulting from grading operations shall be completely removed and properly recompacted prior to foundation excavation.
- Any vegetation or associated root system located within the footprint of the proposed structures should be removed during grading.
- Subsequent to the indicated removals, the exposed grade shall be scarified to a depth of six inches, moistened to optimum moisture content, and recompacted in excess of the minimum required comparative density.
- The excavated areas shall be observed by the geotechnical engineer prior to placing compacted fill.

Recommended Overexcavation and Blending

The proposed building areas shall be excavated to a minimum depth of 5 feet below the proposed grade, or 3 feet below the bottom of all foundations, whichever is greater. The excavation shall extend at least 3 feet beyond the edge of foundations or for a distance equal to the depth of fill below the foundations, whichever is greater. It is very important that the positions of the proposed structures are accurately located so that the limits of the graded area are accurate and the grading operation proceeds efficiently.

Once the onsite soils have been removed it is recommended that they should be blended to reduce the overall expansion index of the newly placed controlled fill. Where the site grading will result in a net export, the sandier or more granular materials should be segregated from the



stockpiled soils and the more clayey or expansive materials should be exported. Samples of the segregated and/or blended soils should be tested by this office to ascertain the expansion index prior to placement and compaction.

Compaction

All fill should be mechanically compacted in layers not more than 8 inches thick. Based on the high expansion index of the site soils, it is recommended that fill materials are moisture conditioned to approximately 3 percent over optimum moisture content before recompaction.

All fill should be mechanically compacted in layers not more than 8 inches thick. The City of Los Angeles Department of Building and Safety requires a minimum comparative compaction of 95 percent of the laboratory maximum density where the soils to be utilized in the fill have less than 15 percent finer than 0.005 millimeters. Comparative compaction is defined, for purposes of these guidelines, as the ratio of the in-place density to the maximum density as determined by applicable ASTM testing.

Field observation and testing shall be performed by a representative of the geotechnical engineer during grading to assist the contractor in obtaining the required degree of compaction and the proper moisture content. Where compaction is less than required, additional compactive effort shall be made with adjustment of the moisture content, as necessary, until a minimum of 90 percent (or 95 percent for cohesionless soils having less than 15 percent finer than 0.005 millimeters) compaction is obtained.

Acceptable Materials

The excavated onsite materials are considered satisfactory for reuse in the controlled fills as long as any debris and/or organic matter is removed. Any imported materials shall be observed and tested by the representative of the geotechnical engineer prior to use in fill areas. Imported



materials should contain sufficient fines so as to be relatively impermeable and result in a stable subgrade when compacted. Any required import materials should consist of geologic materials with an expansion index of less than 60. The water-soluble sulfate content of the import materials should be less than 0.1% percentage by weight.

Imported materials should be free from chemical or organic substances which could affect the proposed development. A competent professional should be retained in order to test imported materials and address environmental issues and organic substances which might affect the proposed development.

Utility Trench Backfill

Utility trenches should be backfilled with controlled fill. The utility should be bedded with clean sands at least one foot over the crown. The remainder of the backfill may be onsite soil compacted to 90 percent (or 95 percent for cohesionless soils having less than 15 percent finer than 0.005 millimeters) of the laboratory maximum density. Utility trench backfill should be tested by representatives of this firm in accordance with the most recent revision of ASTM D-1557.

Wet Soils

At the time of exploration some of the soils which will be exposed during grading and at the bottom of the excavations were locally above optimum moisture content. It is anticipated that the some of the excavated material to be placed as compacted fill, and some of the materials exposed at the bottom of excavated planes may require drying and aeration prior to recompaction.



Pumping (yielding or vertical deflection) of the high-moisture content soils at the bottom of the excavations may occur during operation of heavy equipment. Where pumping is encountered, angular minimum ¾-inch gravel should be placed and worked into the subgrade. The exact thickness of the gravel would be a trial and error procedure, and would be determined in the field. It would likely be on the order of 1 to 2 feet thick.

The gravel will help to densify the subgrade as well as function as a stabilization material upon which heavy equipment may operate. It is not recommended that rubber tire construction equipment attempt to operate directly on the pumping subgrade soils prior to placing the gravel. Direct operation of rubber tire equipment on the soft subgrade soils will likely result in excessive disturbance to the soils, which in turn will result in a delay to the construction schedule since those disturbed soils would then have to be removed and properly recompacted. Extreme care should be utilized to place gravel as the subgrade becomes exposed.

Shrinkage

Shrinkage results when a volume of soil removed at one density is compacted to a higher density. A shrinkage factor between 5 and 15 percent should be anticipated when excavating and recompacting the existing fill and underlying native geologic materials on the site to an average comparative compaction of 92 percent.

Weather Related Grading Considerations

When rain is forecast all fill that has been spread and awaits compaction shall be properly compacted prior to stopping work for the day or prior to stopping due to inclement weather. These fills, once compacted, shall have the surface sloped to drain to an area where water can be removed.



Temporary drainage devices should be installed to collect and transfer excess water to the street in non-erosive drainage devices. Drainage should not be allowed to pond anywhere on the site, and especially not against any foundation or retaining wall. Drainage should not be allowed to flow uncontrolled over any descending slope.

Work may start again, after a period of rainfall, once the site has been reviewed by a representative of this office. Any soils saturated by the rain shall be removed and aerated so that the moisture content will fall within three percent of the optimum moisture content.

Surface materials previously compacted before the rain shall be scarified, brought to the proper moisture content and recompacted prior to placing additional fill, if considered necessary by a representative of this firm.

Abandoned Seepage Pits

No abandoned seepage pits were encountered during exploration and none are known to exist on the site. However, should such a structure be encountered during grading, options to permanently abandon seepage pits include complete removal and backfill of the excavation with compacted fill, or drilling out the loose materials and backfilling to within a few feet of grade with slurry, followed by a compacted fill cap.

If the subsurface structures are to be removed by grading, the entire structure should be demolished. The resulting void may be refilled with compacted soil. Concrete and brick generated during the seepage pit removal may be reused in the fill as long as all fragments are less than 6 inches in longest dimension and the debris comprises less than 15 percent of the fill by volume. All grading should comply with the recommendations of this report.



Where the seepage pit structure is to be left in place, the seepage pits should be cleaned of all soil and debris. This may be accomplished by drilling. The pits should be filled with minimum 1½ sack concrete slurry to within 5 feet of the bottom of the proposed foundations. In order to provide a more uniform foundation condition, the remainder of the void should be filled with controlled fill.

Geotechnical Observations and Testing During Grading

Geotechnical observations and testing during grading are considered to be a continuation of the geotechnical investigation. It is critical that the geotechnical aspects of the project be reviewed by representatives of Geotechnologies, Inc. during the construction process. Compliance with the design concepts, specifications or recommendations during construction requires review by this firm during the course of construction. Any fill which is placed should be observed, tested, and verified if used for engineered purposes. Please advise this office at least twenty-four hours prior to any required site visit.

LEED Considerations

The Leadership in Energy and Environmental Design (LEED) Green Building Rating System encourages adoption of sustainable green building and development practices. Credit for LEED Certification can be assigned for reuse of construction waste and diversion of materials from landfills in new construction.

In an effort to provide the design team with a viable option in this regard, demolition debris could be crushed onsite in order to use it in the ongoing grading operations. The environmental ramifications of this option, if any, should be considered by the team. The demolition debris should be limited to concrete, asphalt and other non-deleterious materials. All deleterious materials should be removed including, but not limited to, paper, garbage, ceramic materials and wood.



For structural fill applications, the materials should be crushed to 2 inches in maximum dimension or smaller. The crushed materials should be thoroughly blended and mixed with onsite soils prior to placement as compacted fill. The amount of crushed material should not exceed 20 percent. The blended and mixed materials should be tested by this office prior to placement to insure it is suitable for compaction purposes. The blended and mixed materials should be tested by Geotechnologies, Inc. during placement to insure that it has been compacted in a suitable manner.

FOUNDATION DESIGN

Conventional

The proposed structure may be supported by conventional foundations bearing in a newly built uniform compacted fill pad. Where perimeter foundations will be built immediately adjacent to the property line, and the recommended compacted fill pad horizontal over-excavation will not be possible, the affected foundations shall be deepened through any fill to bear in undisturbed native alluvial soils.

In addition, conventional foundations proposed within the northern and eastern portion of the site shall be deepened as appropriate, to prevent the surcharge of neighboring foundations. The bottom of these foundations shall extend below a 1:1 (45 degree) surcharge plane, which is projected upward from the bottom of the neighboring foundations.

Where a foundation requires deepening to bear in native soils, the deepened portion of the proposed foundation should be backfilled with hard rock concrete having the same strength as the planned structural footing. The initial pour would not require reinforcing as it is simply passing the load through to the competent native soils. Once the initial pour has hardened, the footing may be reinforced and poured on top of the first pour. Some method of creating a positive bond between the two pours should be employed.



Continuous foundations may be designed for a bearing capacity of 2,500 pounds per square foot, and should be a minimum of 12 inches in width, 24 inches in depth below the lowest adjacent grade and 24 inches into the recommended bearing material.

Column foundations may be designed for a bearing capacity of 3,000 pounds per square foot, and should be a minimum of 24 inches in width, 24 inches in depth below the lowest adjacent grade and 24 inches into the recommended bearing material.

The bearing capacity increase for each additional foot of width is 100 pounds per square foot. The bearing capacity increase for each additional foot of depth is 250 pounds per square foot. The maximum recommended bearing capacity is 5,000 pounds per square foot.

The bearing capacities indicated above are for the total of dead and frequently applied live loads, and may be increased by one third for short duration loading, which includes the effects of wind or seismic forces.

Foundation Reinforcement

All continuous foundations should be reinforced with a minimum of four #4 steel bars. Two should be placed near the top of the foundation, and two should be placed near the bottom.

Lateral Design

Resistance to lateral loading may be provided by friction acting at the base of foundations and by passive earth pressure. An allowable coefficient of friction of 0.30 may be used with the dead load forces.

Passive geologic pressure for the sides of foundations poured against undisturbed or recompacted soil may be computed as an equivalent fluid having a density of 250 pounds per cubic foot with a maximum earth pressure of 1,500 pounds per square foot.



The passive and friction components may be combined for lateral resistance without reduction. A one-third increase in the passive value may be used for short duration loading such as wind or seismic forces.

Foundation Settlement

Settlement of the foundation system is expected to occur on initial application of loading. This firm has prepared two settlement analyses, which calculate the anticipated settlement of the heaviest column foundations, for conditions where they bear in compacted fill and native alluvial soils. Copies of these analyses may be found in the Appendix of this report.

Based on these enclosed analyses, the maximum column foundation settlement anticipated for foundations bearing in compacted fill materials would be 0.99 inches, while the maximum column foundation settlement anticipated for foundations bearing in native soils would be on the order of 1.01 inches. The maximum differential settlement for the proposed foundation system is not expected to exceed ½-inch, and occur over a distance of approximately 30 feet.

Foundation Observations

It is critical that all foundation excavations are observed by a representative of this firm to verify penetration into the recommended bearing materials. The observation should be performed prior to the placement of reinforcement. Foundations should be deepened to extend into satisfactory geologic materials, if necessary.

Foundation excavations should be cleaned of all loose soils prior to placing steel and concrete. Any required foundation backfill should be mechanically compacted, flooding is not permitted.



RETAINING WALL DESIGN

The proposed structure is expected to be built near the existing grade. Therefore, the only retaining walls anticipated would be associated with the construction of elevator pits, planters, or shallow perimeter walls where the interior finished floor elevation will be slightly lower than the outdoor grade.

At this time, it is unknown if the proposed retaining walls will be serviced by a subdrain system. If the installation of a subdrain system will be omitted, the walls shall be designed for an undrained condition with full hydrostatic pressure. Recommendations for drained and undrained conditions are provided herein.

Additional pressure should be added to the retaining wall design, for a surcharge condition due to vehicular traffic or adjacent structures. At this time, it is not anticipated that the retaining walls will be surcharged by existing structures or traffic. For traffic surcharge, the upper 10 feet of any retaining wall adjacent to streets, driveways or parking areas should be designed to resist a uniform lateral pressure of 100 pounds per square foot, acting as a result of an assumed 300 pounds per square foot traffic surcharge. If the traffic is more than 10 feet from the retaining walls, the traffic surcharge may be neglected.

Cantilever Retaining Walls

Retaining walls supporting a level backslope may be designed utilizing a triangular distribution of pressure. Cantilever retaining walls may be designed utilizing the following table:

Height of Retaining Wall	Cantilever Retaining Wall <u>with</u> Wall Subdrain System Triangular Distribution of Active Earth Pressure	Cantilever Retaining Wall <u>without</u> Wall Subdrain System Triangular Distribution of Active Earth Pressure
Up to 6 feet	45 pcf	98 pcf (includes hydrostatic pressure)



The highly expansive properties of the on-site soils have been considered in the development of the recommended lateral earth pressure. For this equivalent fluid pressure to be valid, walls which are to be restrained at the top should be backfilled prior to the upper connection being made. Additional active pressure should be added for a surcharge condition due to sloping ground, vehicular traffic or adjacent structures.

Restrained Retaining Walls

Restrained retaining walls may be designed to resist a triangular pressure distribution of at-rest earth pressure. Restrained retaining walls may be designed utilizing the following table:

Height of Retaining Wall	Restrained Retaining Wall <u>with</u> Wall Subdrain System Triangular Distribution of At-Rest Earth Pressure	Restrained Retaining Wall <u>without</u> Wall Subdrain System Triangular Distribution of At-Rest Earth Pressure
Up to 6 feet	68 pcf	95 pcf (includes hydrostatic pressure)

Additional active pressure should be added for a surcharge condition due to sloping ground, vehicular traffic or adjacent structures.

Dynamic (Seismic) Earth Pressure

Based on the California Building Code, retaining walls exceeding 6 feet in height shall be designed to resist the additional earth pressure caused by seismic ground shaking. Miscellaneous retaining walls anticipated for the proposed project are not expected to exceed 6 feet in height. Therefore, the dynamic earth pressure may be omitted.



Surcharge from Adjacent Structures

The following surcharge equation provided in the LADBS Information Bulletin Document No. P/BC 2020-83, may be utilized to determine the surcharge loads on basement walls and shoring system for existing structures located within the 1:1 (h:v) surcharge influence zone of the excavation and basement.

Resultant lateral force: $R = (0.3 * P * h^2) / (x^2 + h^2)$

Location of lateral resultant: $d = x * [(x^2 / h^2 + 1) * \tan^{-1}(h/x) - (x/h)]$

where:

- R = resultant lateral force measured in pounds per foot of wall width.
- P = resultant surcharge loads of continuous or isolated footings measured in pounds per foot of length parallel to the wall.
- x = distance of resultant load from back face of wall measured in feet.
- h = depth below point of application of surcharge loading to bottom of wall footing measured in feet.
- d = depth of lateral resultant below point of application of surcharge loading measure in feet.
- $\tan^{-1}(h/x)$ = the angle in radians whose tangent is equal to h/x.

The structural engineer may use this equation to determine the surcharge loads based on the loading of the adjacent structures located within the surcharge influence zone.

Retaining Wall Drainage

If the retaining wall will be designed for a drained condition, the retaining walls should be provided with a subdrain covered with a minimum of 12 inches of gravel, and a compacted fill blanket or other seal at the surface. The onsite geologic materials are acceptable for use as retaining wall backfill as long as they are compacted to a minimum of 90 percent (or 95 percent for cohesionless soils having less than 15 percent finer than 0.005 millimeters) of the maximum density as determined by the most recent revision of ASTM D 1557.



As an alternative to the standard perforated subdrain pipe and gravel drainage system, the use of gravel pockets and weepholes is an acceptable drainage method. Weepholes shall be a minimum of 2 inches in diameter, placed at 8 feet on center along the base of the wall. Gravel pockets shall be a minimum of 1 cubic foot in dimension, and may consist of three-quarter inch to one-inch crushed rocks, wrapped in filter fabric. Subdrainage pipes should outlet to an acceptable location. Certain types of subdrain pipe are not acceptable to the various municipal agencies, it is recommended that prior to purchasing subdrainage pipe, the type and brand is cleared with the proper municipal agencies.

If a drainage system is not provided, the walls should be designed to resist an external hydrostatic pressure due to water in addition to the lateral earth pressure. Lateral pressures based on a hydrostatic design are provided in a previous section of this report.

Sump Pump Design

The purpose of the recommended retaining wall backdrainage system is to relieve hydrostatic pressure. Groundwater was encountered at a depth of 20 feet below the existing grade. Therefore, the only water which could affect the proposed retaining walls would be irrigation water and precipitation. Additionally, the proposed site grading is such that all drainage is directed to the street and the structure has been designed with adequate non-erosive drainage devices.

Based on these considerations the retaining wall backdrainage system is not expected to experience an appreciable flow of water, and in particular, no groundwater will affect it. However, for the purposes of design, a flow of 5 gallons per minute may be assumed.



Waterproofing

Moisture effecting retaining walls is one of the most common post construction complaints. Poorly applied or omitted waterproofing can lead to efflorescence or standing water inside the building. Efflorescence is a process in which a powdery substance is produced on the surface of the concrete by the evaporation of water. The white powder usually consists of soluble salts such as gypsum, calcite, or common salt. Efflorescence is common to retaining walls and does not affect their strength or integrity.

It is recommended that retaining walls be waterproofed. Waterproofing design and inspection of its installation is not the responsibility of the geotechnical engineer. A qualified waterproofing consultant should be retained in order to recommend a product or method which would provide protection to below grade walls.

Retaining Wall Backfill

Any required backfill should be mechanically compacted in layers not more than 8 inches thick, to at least 90 percent (or 95 percent for cohesionless soils having less than 15 percent finer than 0.005 millimeters) of the maximum density obtainable by the most recent revision of ASTM D 1557 method of compaction. Flooding should not be permitted. Compaction within 5 feet, measured horizontally, behind a retaining structure should be achieved by use of light weight, hand operated compaction equipment.

Proper compaction of the backfill will be necessary to reduce settlement of overlying walks and paving. Some settlement of required backfill should be anticipated, and any utilities supported therein should be designed to accept differential settlement.



TEMPORARY EXCAVATIONS

Based on the depths of fill encountered during exploration, and anticipating that the proposed foundations may extend to depths ranging between 2 and 4 feet, it is expected that temporary excavations in the order of 5 to 7 feet in depth will be required for the recommended grading and foundation construction. Deeper temporary excavations will be required if deeper fill materials are encountered during construction, or if deeper foundations will be required. It is recommended that potholing be conducted prior to construction, in order to anticipate the presence of deeper fill materials.

The on-site fill and native soils are suitable for vertical excavations up to 5 feet where not surcharged by adjacent traffic, structures or property lines. Surcharged and unsurcharged vertical excavations may be performed to a maximum height of 7 feet with the aid of slot-cuts, as recommended in the following section. Temporary shoring will be required for vertical excavations exceeding a height of 7 feet. Trench shoring may be utilized for the deepening of foundations.

Where sufficient space is available, temporary unsurcharged embankments could be cut at a uniform 1:1 slope gradient to a maximum depth of 15 feet. A uniform sloped excavation is sloped from bottom to top and does not have a vertical component.

Where sloped embankments are utilized, the tops of the slopes should be barricaded to prevent vehicles and storage loads near the top of slope within a horizontal distance equal to the depth of the excavation. If the temporary construction embankments are to be maintained during the rainy season, berms are strongly recommended along the tops of the slopes to prevent runoff water from entering the excavation and eroding the slope faces. Water should not be allowed to pond on top of the excavation nor to flow towards it.



Slot Cutting

Where a property line, the public right of way, an adjacent structure, or traffic will surcharge a temporary excavation, the slot cutting method may be utilized to maintain a stable excavation. The slot cutting method may also be utilized for the deepening of foundations. The height of the excavation is limited to 7 feet. The “A-B-C” slot-cutting procedure is recommended.

The slot cutting method employs the earth as a buttress and allows the earth excavation to proceed in phases. The initial excavation consists of excavating the “A” slots. Alternate “A” slots of 8 feet may be worked. The remaining earth buttresses (“B” and “C” slots) should be 8 feet in width for a combined intervening length of 16 feet. The “A” slots should be properly backfilled, before the “B” slots are excavated. The height of the slots shall not exceed 7 feet in height. Calculations indicating that slots 8 feet in width will be stable for the maximum recommended height of 7 feet, including a surcharge load from adjacent walls and vehicular traffic, have been included in the appendix of this report.

Trench Shoring

Where necessary, a temporary trench shoring system may be utilized to stabilize new foundation excavations. Temporary trench shoring may consist of plywood, timber struts and angle braces, or a hydraulic trench shoring system. Temporary shoring and bracing systems up to 10 feet in height should be designed for a triangular pressure distribution with a minimum equivalent fluid pressure of 28 pounds per cubic foot. Additional active pressure should be added for a surcharge condition due to adjacent structures or vehicular traffic. It is recommended that a qualified shoring contractor be retained to determine the acceptable materials and procedures to be utilized for shoring.

The design team and contractor must be aware that the use of temporary shoring may impede the continuous construction of foundations. Foundations may require to be poured in several phases to accommodate for the removal of the trench shoring, while maintaining a stable excavation.



SHORING DESIGN

Conventional shoring may also be utilized to stabilize grading or foundation excavations. The following information on the design and installation of the shoring is as complete as possible at this time. It is suggested that Geotechnologies, Inc. review the final shoring plans and specifications prior to bidding or negotiating with a shoring contractor.

One method of shoring would consist of steel soldier piles, placed in drilled holes and backfilled with concrete. Based on the anticipated excavation depth, it is anticipated that the soldier piles will be designed for a cantilever condition.

Soldier Piles

Drilled cast-in-place soldier piles should be placed no closer than 2½ diameters on center. The minimum diameter of the piles is 18 inches. Structural concrete should be used for the soldier piles below the excavation; lean-mix concrete may be employed above that level. As an alternative, lean-mix concrete may be used throughout the pile where the reinforcing consists of a wideflange section. The slurry must be of sufficient strength to impart the lateral bearing pressure developed by the wideflange section to the earth materials. For soldier pile design purposes, an allowable passive value for the earth materials below the bottom plane of excavation may be assumed to be 500 pounds per square foot per foot of depth, up to a maximum of 5,000 pounds per square foot. To develop the full lateral value, provisions should be implemented to assure firm contact between the soldier piles and the undisturbed earth materials.

Groundwater was encountered during exploration at depths ranging between 20 and 21½ feet below the existing site grade. Piles placed below the water level require the use of a tremie to place the concrete into the bottom of the hole. A tremie shall consist of a water-tight tube having a diameter of not less than 10 inches with a hopper at the top. The tube shall be equipped with a



device that will close the discharge end and prevent water from entering the tube while it is being charged with concrete. The tremie shall be supported so as to permit free movement of the discharge end over the entire top surface of the work and to permit rapid lowering when necessary to retard or stop the flow of concrete. The discharge end shall be closed at the start of the work to prevent water entering the tube and shall be entirely sealed at all times, except when the concrete is being placed. The tremie tube shall be kept full of concrete. The flow shall be continuous until the work is completed and the resulting concrete seal shall be monolithic and homogeneous. The tip of the tremie tube shall always be kept about five feet below the surface of the concrete and definite steps and safeguards should be taken to insure that the tip of the tremie tube is never raised above the surface of the concrete.

A special concrete mix should be used for concrete to be placed below water. The design shall provide for concrete with a strength p.s.i. of 1,000 over the initial job specification. An admixture that reduces the problem of segregation of paste/aggregates and dilution of paste shall be included. The slump shall be commensurate to any research report for the admixture, provided that it shall also be the minimum for a reasonable consistency for placing when water is present.

Where caving occurs, it will be necessary to utilize casing or polymer drilling fluid to maintain open pile shafts. If casing is used, extreme care should be employed so that the pile is not pulled apart as the casing is withdrawn. At no time should the distance between the surface of the concrete and the bottom of the casing be less than 5 feet.

The frictional resistance between the soldier piles and retained geologic material may be used to resist the vertical component of the anchor load. The coefficient of friction may be taken as 0.30 based on uniform contact between the steel beam and lean-mix concrete and retained earth. The portion of soldier piles below the plane of excavation may also be employed to resist the downward loads. The downward capacity may be determined using a frictional resistance of 500 pounds per square foot. The minimum depth of embedment for shoring piles is 5 feet below the bottom of the footing excavation or 5 feet below the bottom of excavated plane whichever is deeper.



Lagging

Soldier piles and anchors should be designed for the full anticipated pressures. Due to arching in the geologic materials, the pressure on the lagging will be less. It is recommended that the lagging should be designed for the full design pressure but be limited to a maximum of 400 pounds per square foot. It is recommended that a representative of this firm observe the installation of lagging to insure uniform support of the excavated embankment.

Lateral Pressures

Cantilevered shoring supporting a level backslope may be designed utilizing a triangular distribution of pressure as indicated in the following table:

HEIGHT OF SHORING "H" (feet)	EQUIVALENT FLUID PRESSURE (pounds per cubic foot)
Up to 10	28

Where a combination of sloped embankment and shoring is utilized, the pressure will be greater and must be determined for each combination. Additional active pressure should be applied where the shoring will be surcharged by adjacent traffic or structures.

Deflection

It is difficult to accurately predict the amount of deflection of a shored embankment. It should be realized that some deflection will occur. It is recommended that shoring deflection be limited to ½ inch at the top of the shored embankment where a structure is within a 1:1 plane projected up from the base of the excavation. A maximum deflection of 1-inch has been allowed, provided there are no structures within a 1:1 plane drawn upward from the base of the excavation. If greater deflection occurs during construction, additional bracing may be necessary to minimize settlement of adjacent buildings and utilities in adjacent street and alleys. If desired to reduce the deflection, a greater active pressure could be used in the shoring design.



Monitoring

Because of the depth of the excavation, some means of monitoring the performance of the shoring system is suggested. The monitoring should consist of periodic surveying of the lateral and vertical locations of the tops of all soldier piles and the lateral movement along the entire lengths of selected soldier piles. Also, some means of periodically checking the load on selected anchors will be necessary, where applicable.

Some movement of the shored embankments should be anticipated as a result of the relatively deep excavation. It is recommended that photographs of the existing buildings on the adjacent properties be made during construction to record any movements for use in the event of a dispute.

Shoring Observations

It is critical that the installation of shoring is observed by a representative of Geotechnologies, Inc. Many building officials require that shoring installation should be performed during continuous observation of a representative of the geotechnical engineer. The observations insure that the recommendations of the geotechnical report are implemented and so that modifications of the recommendations can be made if variations in the geologic material or groundwater conditions warrant. The observations will allow for a report to be prepared on the installation of shoring for the use of the local building official, where necessary.

SLABS ON GRADE

Concrete Slabs-on Grade

Interior concrete floor slabs should be a minimum of 5 inches in thickness. Slabs-on-grade should be cast over undisturbed native alluvial soils or properly controlled fill materials. Any geologic materials loosened or over-excavated should be wasted from the site or properly compacted to 90 percent (or 95 percent for cohesionless soils having less than 15 percent finer than 0.005 millimeters) of the maximum dry density.



Outdoor concrete flatwork should be a minimum of 5 inches in thickness. Outdoor concrete flatwork should be cast over undisturbed native alluvial soils or properly controlled fill materials. Any geologic materials loosened or over-excavated should be wasted from the site or properly compacted to 90 percent (or 95 percent for cohesionless soils having less than 15 percent finer than 0.005 millimeters) of the maximum dry density.

Design of Slabs That Receive Moisture-Sensitive Floor Coverings

Geotechnologies, Inc. does not practice in the field of moisture vapor transmission evaluation and mitigation. Therefore, where necessary, it is recommended that a qualified consultant should be engaged to evaluate the general and specific moisture vapor transmission paths and any impact on the proposed construction. The qualified consultant should provide recommendations for mitigation of potential adverse impacts of moisture vapor on various components of the structure.

Where any dampness would be objectionable or where the slab will be cast below the historic high groundwater level, it is recommended that floor slabs should be waterproofed. A qualified waterproofing consultant should be engaged in order to recommend a product and/or method which would provide protection from unwanted moisture.

Based on ACI 302.2R-30, Chapter 7, for projects which do not have vapor sensitive coverings or humidity-controlled areas, a vapor retarder/barrier is not necessary. Where a vapor retarder/barrier is considered necessary, the design of the slab and the installation of the vapor retarder/barrier should comply with the most recent revisions of ASTM E 1643 and ASTM E 1745. The vapor retarder/barrier should comply with ASTM E 1745 Class A requirements. The necessity of a vapor retarder/barrier is not a geotechnical issue and should be confirmed by qualified members of the design team.



Based on ACI 302.2R-30, Chapter 7, for projects with vapor sensitive coverings, a vapor retarder/ barrier should be provided. Figure 7.1 shows that the slab should be poured on the vapor retarder/barrier. The ACI guide notes in 5.2.3.2 that the decision to locate the vapor retarder/barrier in direct contact with the slab's underside had long been debated. Experience has shown, however, that the greatest level of protection for floor coverings, coating, or building environments is provided when the vapor retarder/barrier is placed in direct contact with the slab. The necessity of a vapor retarder as well as the use of dry granular material, as discussed above is not a geotechnical issue and should be confirmed by qualified members of the design team.

Where a vapor retarder/barrier is used, it should be placed on a level and compact subgrade. Precautions should be taken to protect the vapor retarder/barrier from damage during installation of reinforcing, utilities and concrete. The use of stakes driven through the vapor retarder/barrier should be avoided. Repair any damaged areas of the vapor retarder/barrier prior to concrete placement.

Concrete Crack Control

The recommendations presented in this report are intended to reduce the potential for cracking of concrete slabs-on-grade due to settlement. However even where these recommendations have been implemented, foundations, stucco walls and concrete slabs-on-grade may display some cracking due to minor soil movement and/or concrete shrinkage. The occurrence of concrete cracking may be reduced and/or controlled by limiting the slump of the concrete used, proper concrete placement and curing, and by placement of crack control joints at reasonable intervals, in particular, where re-entrant slab corners occur.

For standard control of concrete cracking, a maximum crack control joint spacing of 8 feet should not be exceeded. Lesser spacings would provide greater crack control. Joints at curves and angle points are recommended. The crack control joints should be installed as soon as practical following concrete placement. Crack control joints should extend a minimum depth of one-fourth the slab thickness. Construction joints should be designed by a structural engineer.



Complete removal of the existing fill soils beneath outdoor flatwork such as walkways or patio areas, is not required, however, due to the rigid nature of concrete, some cracking, a shorter design life and increased maintenance costs should be anticipated. In order to provide uniform support beneath the flatwork it is recommended that a minimum of 12 inches of the exposed subgrade beneath the flatwork be scarified and recompact to 90 percent (or 95 percent for cohesionless soils having less than 15 percent finer than 0.005 millimeters) relative compaction.

Slab Reinforcing

Concrete slabs-on-grade and outdoor flatwork should be reinforced with a minimum of #4 steel bars on 16-inch centers each way.

PAVEMENTS

Prior to placing paving, the existing grade should be scarified to a depth of 12 inches, moistened as required to obtain optimum moisture content, and recompact to 90 percent (or 95 percent for cohesionless soils having less than 15 percent finer than 0.005 millimeters) relative compaction, as determined by the most recent revision of ASTM D 1557. The client should be aware that removal of all existing fill in the area of new paving is not required, however, pavement constructed in this manner will most likely have a shorter design life and increased maintenance costs. The following pavement sections are recommended:

Service	Asphalt Pavement Thickness Inches	Base Course Inches
Passenger Cars Traffic	4	5
Moderate Truck Traffic	5	7

Concrete paving may also be used on the project. For passenger cars and moderate truck traffic, concrete paving should be 6 inches of concrete over 4 inches of compacted base. For standard crack control maximum expansion joint spacing of 8 feet should not be exceeded. Lesser



spacings would provide greater crack control. Joints at curves and angle points are recommended. Concrete paving should be reinforced with a minimum of #4 steel bars on 16-inch centers each way.

Aggregate base should be compacted to a minimum of 95 percent of the most recent revision of ASTM D 1557 laboratory maximum dry density. Base materials should conform to Sections 200-2.2 or 200-2.4 of the “Standard Specifications for Public Works Construction”, (Green Book), latest edition.

The performance of pavement is highly dependent upon providing positive surface drainage away from the edges. Ponding of water on or adjacent to pavement can result in saturation of the subgrade materials and subsequent pavement distress. If planter islands are planned, the perimeter curb should extend a minimum of 12 inches below the bottom of the aggregate base.

SITE DRAINAGE

Proper surface drainage is critical to the future performance of the project. Saturation of a soil can cause it to lose internal shear strength and increase its compressibility, resulting in a change in the designed engineering properties. Proper site drainage should be maintained at all times.

All site drainage, with the exception of any required to be disposed of onsite by stormwater regulations, should be collected and transferred to the street in non-erosive drainage devices. The proposed structure should be provided with roof drainage. Discharge from downspouts, roof drains and scuppers should not be permitted on unprotected soils within five feet of the building perimeter. Drainage should not be allowed to pond anywhere on the site, and especially not against any foundation or retaining wall. Drainage should not be allowed to flow uncontrolled over any descending slope. Planters which are located within a distance equal to the depth of a retaining wall should be sealed to prevent moisture adversely affecting the wall. Planters which are located within five feet of a foundation should be sealed to prevent moisture affecting the earth materials supporting the foundation.



STORMWATER DISPOSAL

Recently regulatory agencies have been requiring the disposal of a certain amount of stormwater generated on a site by infiltration into the site soils. Increasing the moisture content of a soil can cause it to lose internal shear strength and increase its compressibility, resulting in a change in the designed engineering properties. This means that any overlying structure, including buildings, pavements and concrete flatwork, could sustain damage due to saturation of the subgrade soils. Structures serviced by subterranean levels could be adversely impacted by stormwater disposal by increasing the design fluid pressures on retaining walls and causing leaks in the walls. Proper site drainage is critical to the performance of any structure in the built environment.

Percolation testing of the on-site soils was not conducted by this firm. However, based on the fines content of the majority of the site soils, it is the opinion of this firm that these soils will have poor infiltration capabilities. Allowing stormwater infiltration would result in a perched water condition. In addition, some of the site soils were determined to be highly expansive when saturated.

Groundwater was encountered during exploration, to depths ranging between 20 and 21½ feet below grade. Current regulations require that the bottom of infiltration systems maintain a minimum vertical separation of 10 feet above the groundwater level. Based on the required vertical separation, and the shallowest depth to groundwater observed during exploration, any potential stormwater infiltration to be conducted at the site would have to occur within the upper 10 feet of soils. Infiltration within this upper soil stratum is not recommend, as it would saturate the soils providing primary support to the proposed structure. Saturation of these soils would affect their strength.



Based on the above considerations, stormwater infiltration is not recommended for the subject site. Where infiltration of stormwater into the subgrade soils is not advisable, most Building Officials have allowed the stormwater to be filtered through soils in planter areas. Once the water has been filtered through a planter it may be released into the storm drain system. It is recommended that overflow pipes are incorporated into the design of the discharge system in the planters to prevent flooding. In addition, the planters shall be sealed and waterproofed to prevent leakage. Please be advised that adverse impact to landscaping and periodic maintenance may result due to excessive water and contaminants discharged into the planters.

It is recommended that the design team (including the structural engineer, waterproofing consultant, plumbing engineer, and landscape architect) be consulted in regards to the design and construction of filtration systems.

DESIGN REVIEW

Engineering of the proposed project should not begin until approval of the geotechnical report by the Building Official is obtained in writing. Significant changes in the geotechnical recommendations may result during the building department review process.

It is recommended that the geotechnical aspects of the project be reviewed by this firm during the design process. This review provides assistance to the design team by providing specific recommendations for particular cases, as well as review of the proposed construction to evaluate whether the intent of the recommendations presented herein are satisfied.

CONSTRUCTION MONITORING

Geotechnical observations and testing during construction are considered to be a continuation of the geotechnical investigation. It is critical that this firm review the geotechnical aspects of the project during the construction process. Compliance with the design concepts, specifications or recommendations during construction requires review by this firm during the course of



construction. All foundations should be observed by a representative of this firm prior to placing concrete or steel. Any fill which is placed should be observed, tested, and verified if used for engineered purposes. Please advise Geotechnologies, Inc. at least twenty-four hours prior to any required site visit.

If conditions encountered during construction appear to differ from those disclosed herein, notify Geotechnologies, Inc. immediately so the need for modifications may be considered in a timely manner.

It is the responsibility of the contractor to ensure that all excavations and trenches are properly sloped or shored. All temporary excavations should be cut and maintained in accordance with applicable OSHA rules and regulations.

EXCAVATION CHARACTERISTICS

The exploration performed for this investigation is limited to the geotechnical excavations described. Direct exploration of the entire site would not be economically feasible. The owner, design team and contractor must understand that differing excavation and drilling conditions may be encountered based on boulders, gravel, oversize materials, groundwater and many other conditions. Fill materials, especially when they were placed without benefit of modern grading codes, regularly contain materials which could impede efficient grading and drilling. Southern California sedimentary bedrock is known to contain variable layers which reflect differences in depositional environment. Such layers may include abundant gravel, cobbles and boulders. Similarly bedrock can contain concretions. Concretions are typically lenticular and follow the bedding. They are formed by mineral deposits. Concretions can be very hard. Excavation and drilling in these areas may require full size equipment and coring capability. The contractor should be familiar with the site and the geologic materials in the vicinity.



CLOSURE AND LIMITATIONS

The purpose of this report is to aid in the design and completion of the described project. Implementation of the advice presented in this report is intended to reduce certain risks associated with construction projects. The professional opinions and geotechnical advice contained in this report are sought because of special skill in engineering and geology and were prepared in accordance with generally accepted geotechnical engineering practice. Geotechnologies, Inc. has a duty to exercise the ordinary skill and competence of members of the engineering profession. Those who hire Geotechnologies, Inc. are not justified in expecting infallibility, but can expect reasonable professional care and competence.

The recommendations of this report pertain only to the site investigated and are based upon the assumption that the geologic conditions do not deviate from those disclosed in the investigation. If any variations are encountered during construction, or if the proposed construction will differ from that anticipated herein, Geotechnologies, Inc. should be notified so that supplemental recommendations can be prepared.

This report is issued with the understanding that it is the responsibility of the owner, or the owner's representatives, to ensure that the information and recommendations contained herein are brought to the attention of the project architect and engineer and are incorporated into the plans. The owner is also responsible to see that the contractor and subcontractors carry out the geotechnical recommendations during construction.

The findings of this report are valid as of the date of this report. However, changes in the conditions of a property can occur with the passage of time, whether they are due to natural processes or the works of man on this or adjacent properties. In addition, changes in applicable or appropriate standards may occur, whether they result from legislation or the broadening of knowledge. Accordingly, the findings of this report may be invalidated wholly or partially by changes outside control of this firm. Therefore, this report is subject to review and should not be relied upon after a period of three years.



Geotechnical observations and testing during construction is considered to be a continuation of the geotechnical investigation. It is, therefore, most prudent to employ the consultant performing the initial investigative work to provide observation and testing services during construction. This practice enables the project to flow smoothly from the planning stages through to completion.

Should another geotechnical firm be selected to provide the testing and observation services during construction, that firm should prepare a letter indicating their assumption of the responsibilities of geotechnical engineer of record. A copy of the letter should be provided to the regulatory agency for review. The letter should acknowledge the concurrence of the new geotechnical engineer with the recommendations presented in this report.

EXCLUSIONS

Geotechnologies, Inc. does not practice in the fields of methane gas, radon gas, environmental engineering, waterproofing, dewatering organic substances or the presence of corrosive soils or wetlands which could affect the proposed development including mold and toxic mold. Nothing in this report is intended to address these issues and/or their potential effect on the proposed development. A competent professional consultant should be retained in order to address environmental issues, waterproofing, organic substances and wetlands which might affect the proposed development.

GEOTECHNICAL TESTING

Classification and Sampling

The soil is continuously logged by a representative of this firm and classified by visual examination in accordance with the Unified Soil Classification system. The field classification is verified in the laboratory, also in accordance with the Unified Soil Classification System. Laboratory classification may include visual examination, Atterberg Limit Tests and grain size distribution. The final classification is shown on the excavation logs.



Samples of the geologic materials encountered in the exploratory excavations were collected and transported to the laboratory. Undisturbed samples of soil are obtained at frequent intervals. Unless noted on the excavation logs as an SPT sample, samples acquired while utilizing a hollow-stem auger drill rig are obtained by driving a thin-walled, California Modified Sampler with successive 30-inch drops of a 140-pound automatic hammer. The soil is retained in brass rings of 2.50 inches outside diameter and 1.00 inch in height. The central portion of the samples are stored in close fitting, waterproof containers for transportation to the laboratory. Samples noted on the excavation logs as SPT samples are obtained in general accordance with the most recent revision of ASTM D 1586. Samples are retained for 30 days after the date of the geotechnical report.

Moisture and Density Relationships

The field moisture content and dry unit weight are determined for each of the undisturbed soil samples, and the moisture content is determined for SPT samples in general accordance with the most recent revision of ASTM D 4959 or ASTM D 4643. This information is useful in providing a gross picture of the soil consistency between exploration locations and any local variations. The dry unit weight is determined in pounds per cubic foot and shown on the "Excavation Logs", A-Plates. The field moisture content is determined as a percentage of the dry unit weight.

Direct Shear Testing

Shear tests are performed in general accordance with the most recent revision of ASTM D 3080 with a strain controlled, direct shear machine manufactured by Soil Test, Inc. or a Direct Shear Apparatus manufactured by GeoMatic, Inc. The rate of deformation is approximately 0.025 inches per minute. Each sample is sheared under varying confining pressures in order to determine the Mohr-Coulomb shear strength parameters of the cohesion intercept and the angle of internal friction. Samples are generally tested in an artificially saturated condition. Depending upon the sample location and future site conditions, samples may be tested at field moisture content. The results are plotted on the "Shear Test Diagram," B-Plates.



The most recent revision of ASTM 3080 limits the particle size to 10 percent of the diameter of the direct shear test specimen. The sheared sample is inspected by the laboratory technician running the test. The inspection is performed by splitting the sample along the sheared plane and observing the soils exposed on both sides. Where oversize particles are observed in the shear plane, the results are discarded and the test run again with a fresh sample.

Consolidation Testing

Settlement predictions of the soil's behavior under load are made on the basis of the consolidation tests in general accordance with the most recent revision of ASTM D 2435. The consolidation apparatus is designed to receive a single one-inch high ring. Loads are applied in several increments in a geometric progression, and the resulting deformations are recorded at selected time intervals. Porous stones are placed in contact with the top and bottom of each specimen to permit addition and release of pore fluid. Samples are generally tested at increased moisture content to determine the effects of water on the bearing soil. The normal pressure at which the water is added is noted on the drawing. Results are plotted on the "Consolidation Test," C-Plates.

Expansion Index Testing

The expansion tests performed on the remolded samples are in accordance with the Expansion Index testing procedures, as described in the most recent revision of ASTM D 4829. The soil sample is compacted into a metal ring at a saturation degree of 50 percent. The ring sample is then placed in a consolidometer, under a vertical confining pressure of 1 lbf/square inch and inundated with distilled water. The deformation of the specimen is recorded for a period of 24 hour or until the rate of deformation becomes less than 0.0002 inches/hour, whichever occurs first. The expansion index, EI, is determined by dividing the difference between final and initial height of the ring sample by the initial height, and multiplied by 1,000. Results are presented in Plate D of this report.



Laboratory Compaction Characteristics

The maximum dry unit weight and optimum moisture content of a soil are determined in general accordance with the most recent revision of ASTM D 1557. A soil at a selected moisture content is placed in five layers into a mold of given dimensions, with each layer compacted by 25 blows of a 10 pound hammer dropped from a distance of 18 inches subjecting the soil to a total compactive effort of about 56,000 pounds per cubic foot. The resulting dry unit weight is determined. The procedure is repeated for a sufficient number of moisture contents to establish a relationship between the dry unit weight and the water content of the soil. The data when plotted represent a curvilinear relationship known as the compaction curve. The values of optimum moisture content and modified maximum dry unit weight are determined from the compaction curve. Results are presented in Plate D of this report.

Grain Size Distribution

These tests cover the quantitative determination of the distribution of particle sizes in soils. Sieve analysis is used to determine the grain size distribution of the soil larger than the Number 200 sieve. The most recent revision of ASTM D 422 is used to determine particle sizes smaller than the Number 200 sieve. A hydrometer is used to determine the distribution of particle sizes by a sedimentation process. The grain size distributions are plotted on the E-Plate presented in the Appendix of this report.

Atterberg Limits

Depending on their moisture content, cohesive soils can be solid, plastic, or liquid. The water contents corresponding to the transitions from solid to plastic or plastic to liquid are known as the Atterberg Limits. The transitions are called the plastic limit and liquid limit. The difference between the liquid and plastic limits is known as the plasticity index. ASTM D 4318 is utilized to determine the Atterberg Limits. The results are shown on the enclosed F-Plate.



REFERENCES

- California Department of Conservation, 2008, Guidelines for Evaluating and Mitigating Seismic Hazards in California, Special Publication 117A, California Geological Survey.
- California Department of Conservation, Division of Mines and Geology, 1998 (Revised 2006), Seismic Hazard Zone Report of the Hollywood 7½-Minute Quadrangle, Los Angeles County, California., C.D.M.G. Seismic Hazard Zone Report 026, map scale 1:24,000.
- California Department of Conservation, Division of Mines and Geology, 1999, Seismic Hazard Zones Map, Hollywood 7½-minute Quadrangle, CDMG Seismic Hazard Zone Mapping Act of 1990.
- California Geological Survey, 2014, Earthquake Zones of Required Investigation, Hollywood 7½-minute Quadrangle.
- Leighton and Associates, Inc., 1990, Technical Appendix to the Safety Element of the Los Angeles County General Plan: Hazard Reduction in Los Angeles County.
- Poland, J.F., Garell, A.A., AND Sinott, A., 1959, Geology, Hydrology, and Chemical Character of Groundwaters in the Torrance-Santa Monica area, California; U.S. Geological Survey, Water Supply Paper 1461.
- SEAOC/OSHPD U.S. Seismic Design Maps tool.
- State of California Division of Oil, Gas, and Geothermal Resources, Online Mapping System, <http://maps.conservation.ca.gov/doms/doms-app.html>.
- Stewart, J.P., Blake, T.F., and Hollingsworth, R.A., 2003, a screen analysis procedure of seismic slope stability: Earthquake Spectra, v. 19, n. 3, p. 697-712.
- Tinsley, J.C., and Fumal, T.E., 1985, Mapping quaternary Sedimentary Deposits for Areal Variations in Shaking Response, in Evaluation Earthquake Hazards in the Los Angeles Region- An Earth Science Perspective, U.S. Geological Survey Professional Paper 1360, Ziony, J.I. ed., pp 101-125.
- United States Geological Survey, 2014, U.S.G.S. Interactive Deaggregation Program. <http://eqint.cr.usgs.gov/deaggint/2014/index.php>.
- Yerkes, R.F., McCulloh, T.H., Schoellhamer, J.E., Vedder, J.G., Geology of the Los Angeles Basin, Southern California-An Introduction, U.S. Geological Professional Paper 420-A.



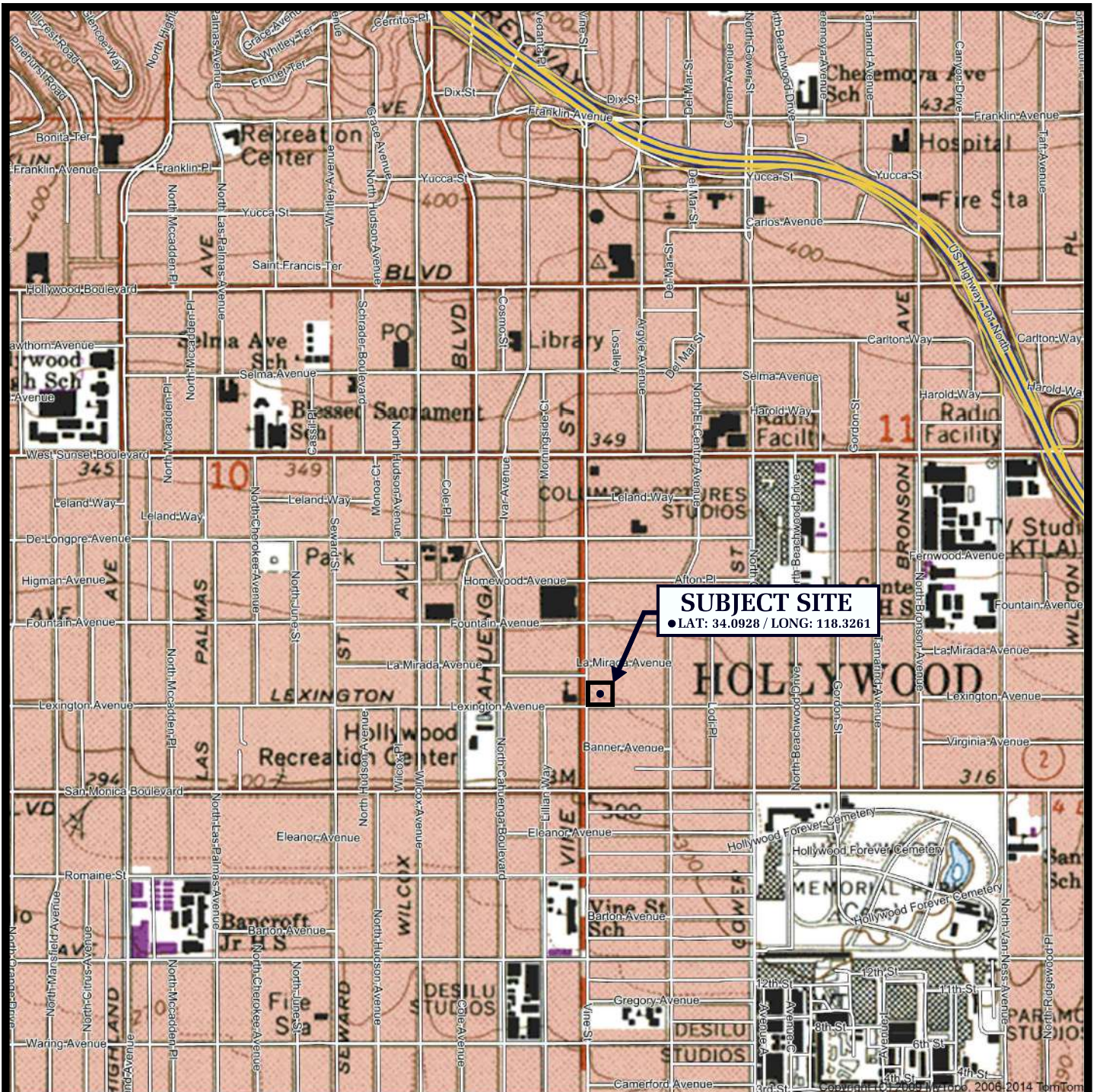

SUBJECT SITE
 ● LAT: 34.0928 / LONG: 118.3261

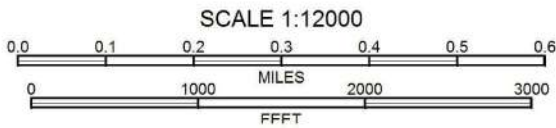

REFERENCE: U.S.G.S. TOPOGRAPHIC MAPS, 7.5 MINUTE SERIES,
 HOLLYWOOD, CA QUADRANGLE

VICINITY MAP

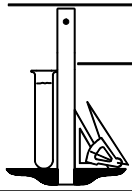

Geotechnologies, Inc.
 Consulting Geotechnical Engineers

GRUBB PROPERTIES
 1200 N. VINE ST., LOS ANGELES, CA

FILE NO. 22207

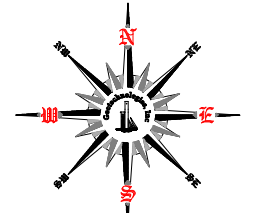
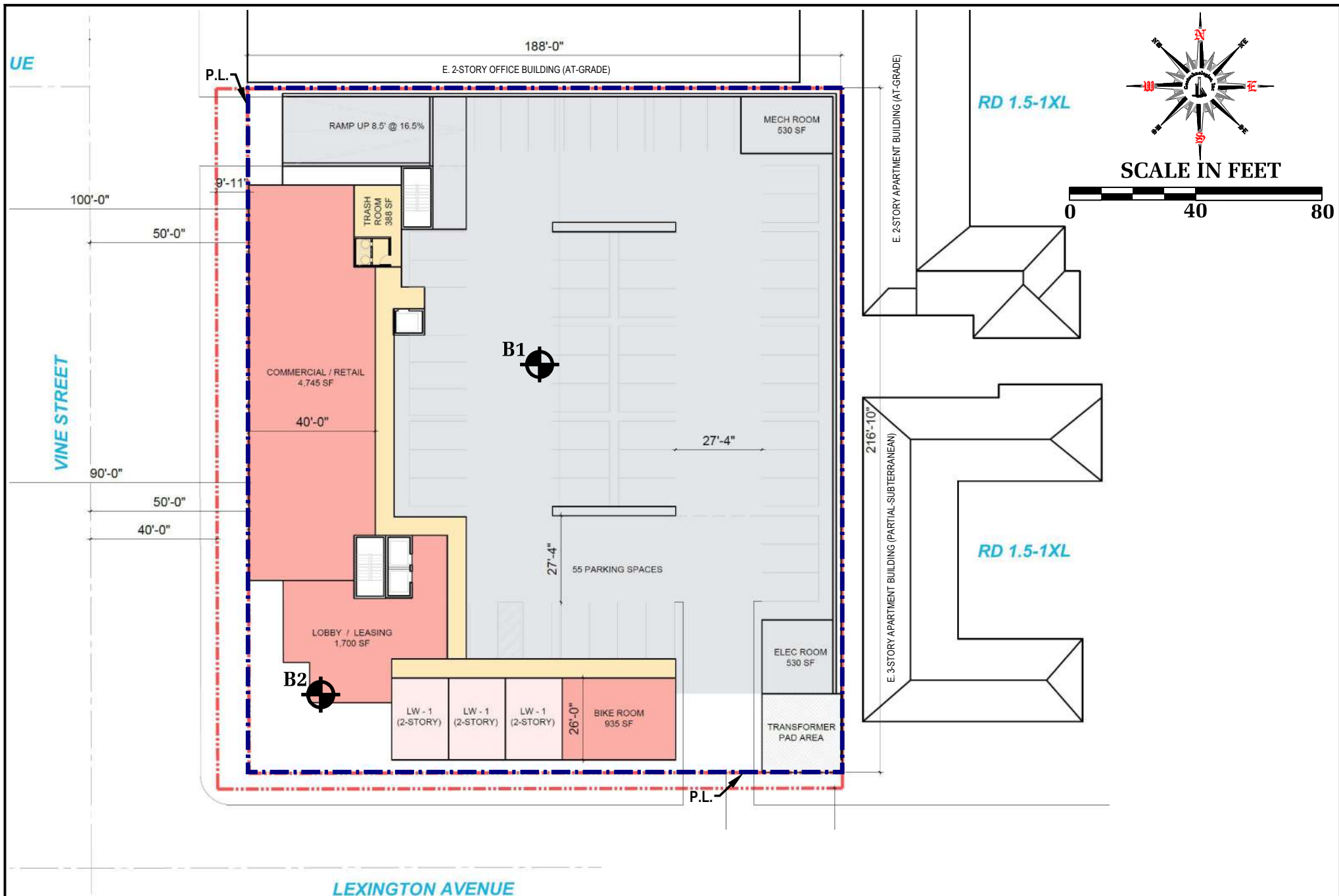

SCALE IN FEET

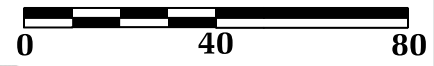

LEGEND

B2 LOCATION & NUMBER OF BORING

REFERENCE: CONCEPTUAL PLAN (LEVEL 1) BY KTG
DATED 10/11/21

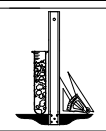

Geotechnologies, Inc.
Consulting Geotechnical Engineers

PLOT PLAN

GRUBB PROPERTIES
1200 N. VINE STREET, LOS ANGELES, CA
File No.: 22207

Date: December 2021

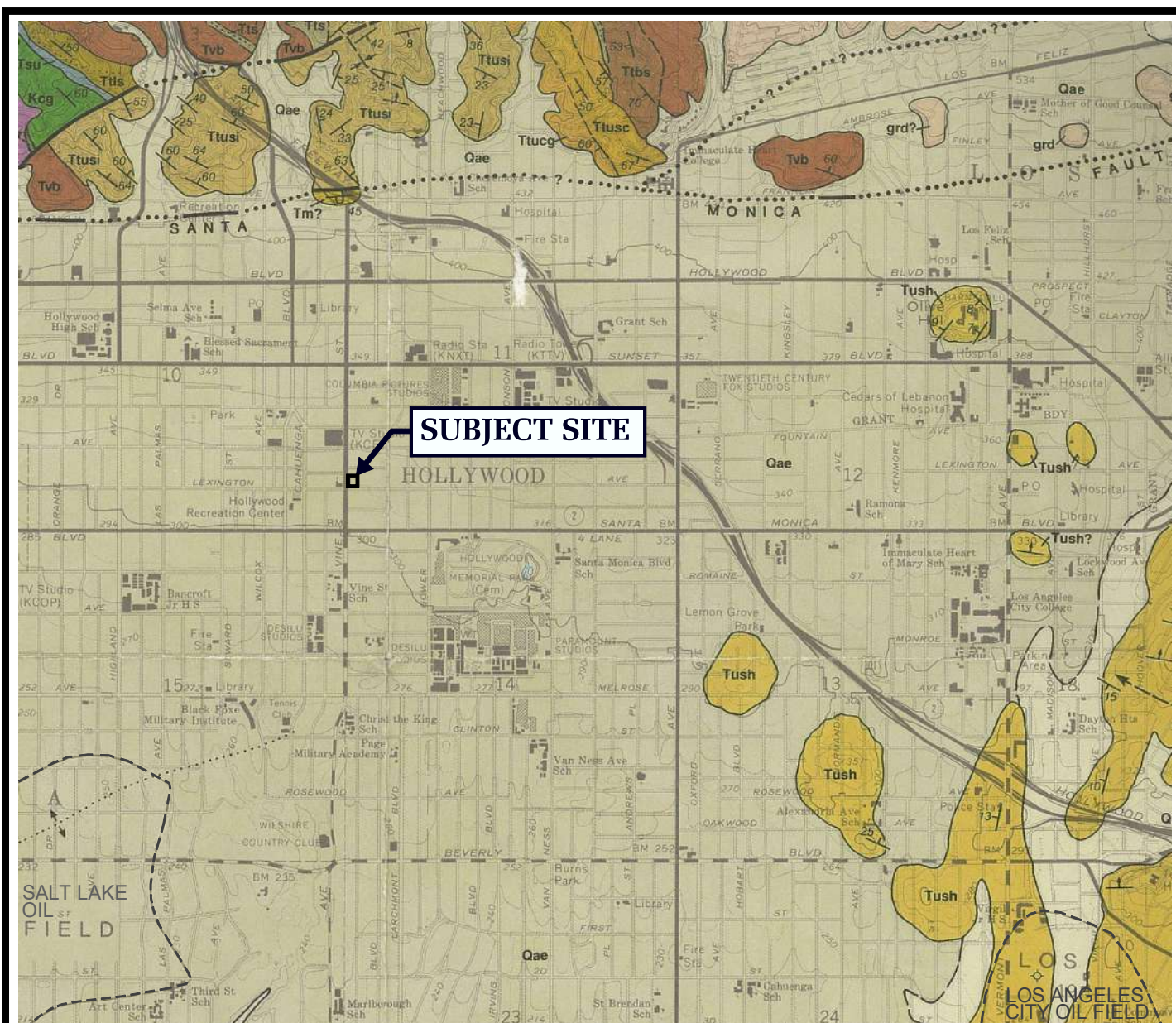

LEGEND

- Qae:** Alluvium- Clay, sand and gravel, slightly elevated and dissected
- Tush:** Unnamed Shale- Silty clay shale
- Ttusi:** Upper Topanga Formation- Clay shale or claystone
- Ttus:** Upper Topanga Formation- Sandstone
- Ttusc:** Upper Topanga Formation- Massive sandstone
- Ttucg:** Upper Topanga Formation- Cahuenga conglomerate
- Tvb:** Middle Topanga Formation- Basaltic volcanic rocks
- Kcg:** Unnamed Streta- Crudely bedded conglomerate
- ? Fault - dashed where indefinite or inferred, dotted where concealed, queried where existence is doubtful



REFERENCE: DIBBLEE, T.W., (1991), MAP #DF-30, GEOLOGIC MAP OF THE HOLLYWOOD AND BURBANK (SOUTH 1/2) QUADRANGLES

LOCAL GEOLOGIC MAP

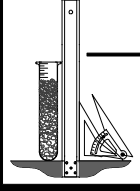

Geotechnologies, Inc.
 Consulting Geotechnical Engineers

GRUBB PROPERTIES
 1200 N. VINE ST., LOS ANGELES, CA

FILE NO. 22207

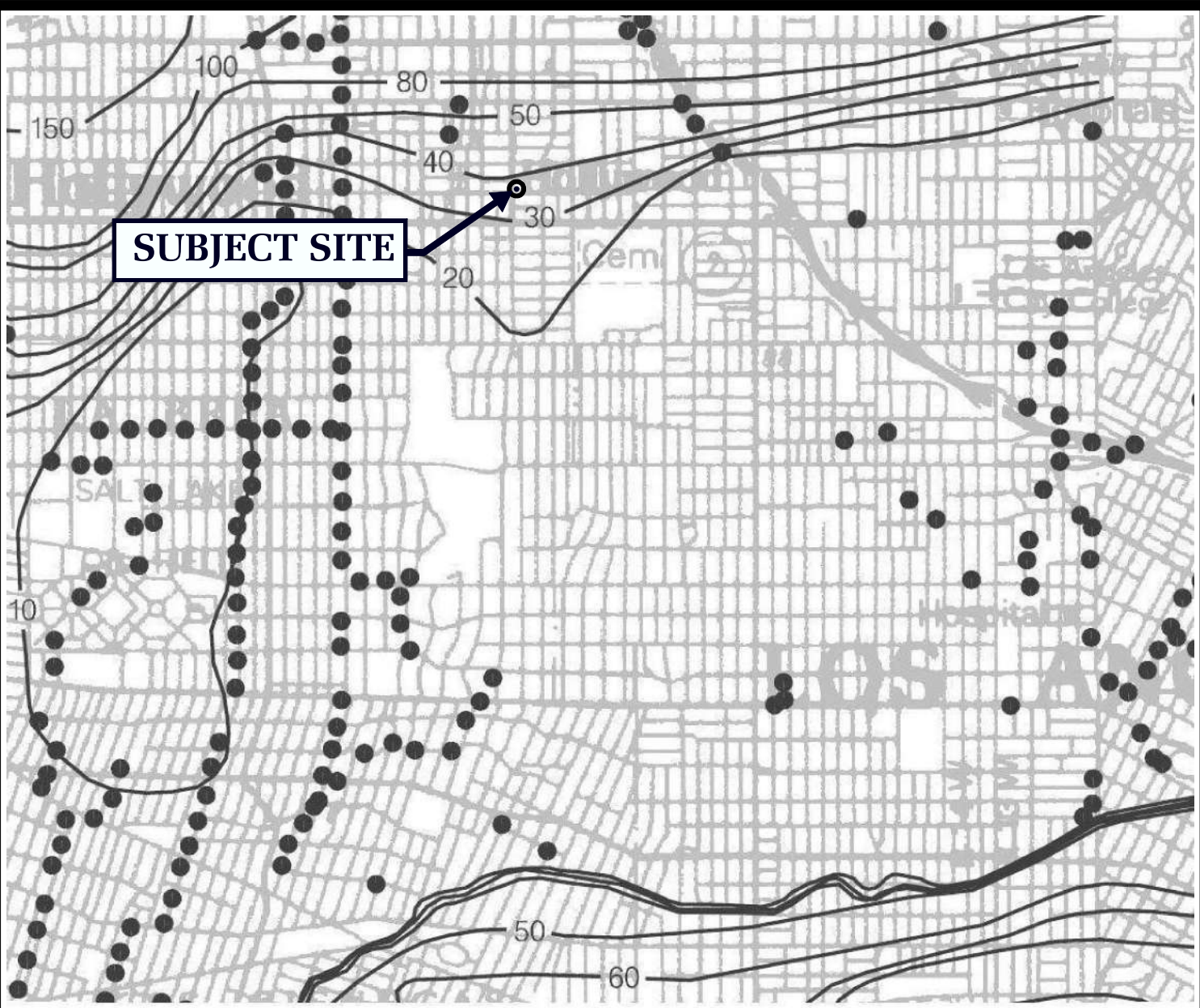

LEGEND

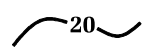
 20 ~ Depth to groundwater in feet

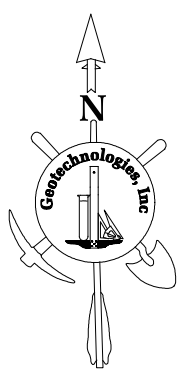

REFERENCE: CDMG, SEISMIC HAZARD ZONE REPORT, 026
 HOLLYWOOD 7.5 - MINUTE QUADRANGLE, LOS ANGELES COUNTY, CALIFORNIA (1998, REVISED 2006)

HISTORICALLY HIGHEST GROUNDWATER LEVELS

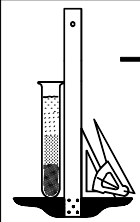

Geotechnologies, Inc.
 Consulting Geotechnical Engineers

GRUBB PROPERTIES
 1200 N. VINE ST., LOS ANGELES, CA

FILE NO. 22207

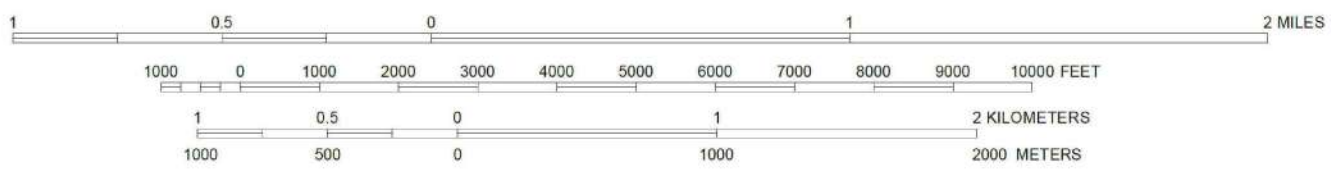
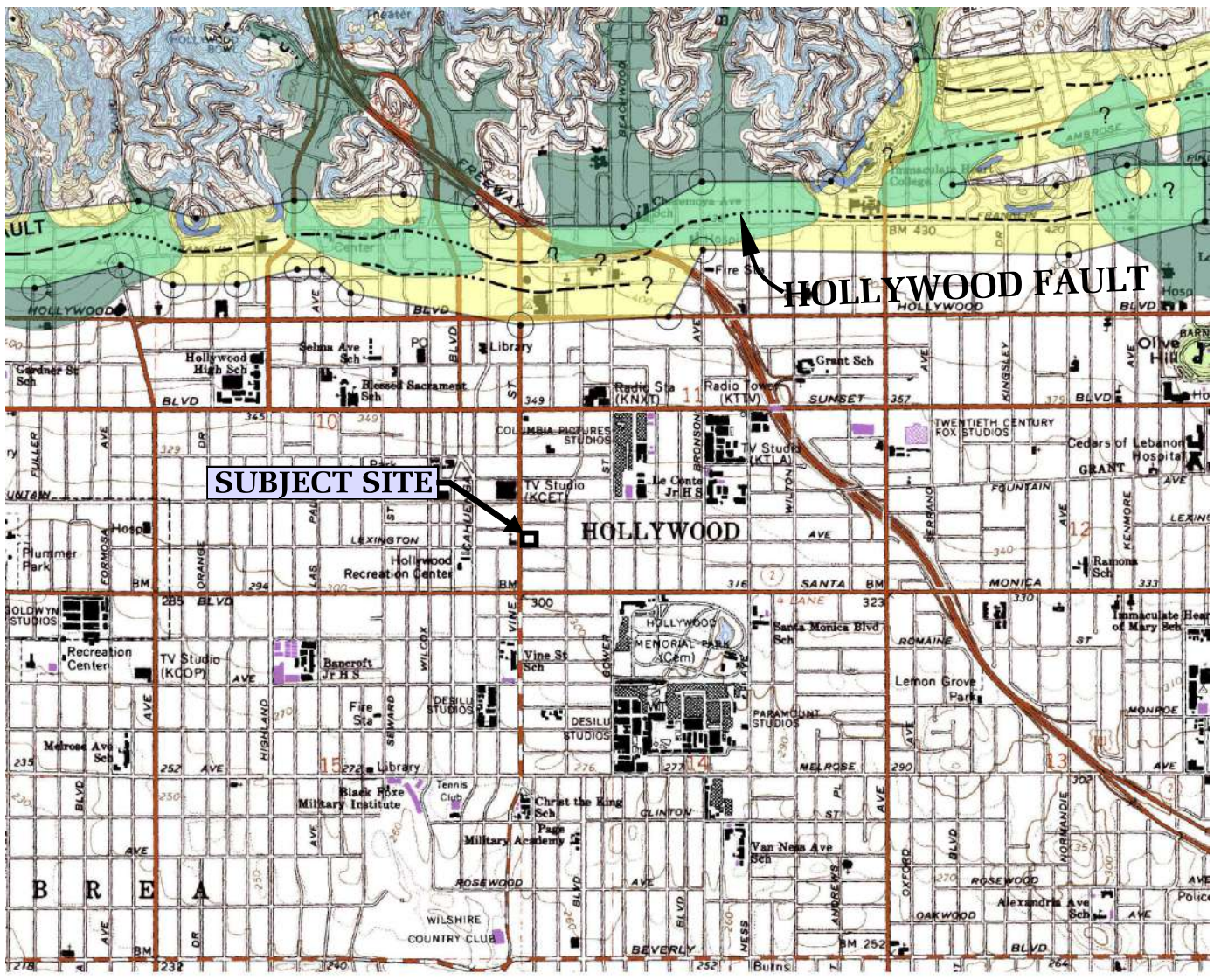

-  Earthquake Fault Zones
-  Alquist-Priolo Earthquake Fault Zone
-  Liquefaction Area

Contour Interval 20 Feet



REFERENCE: EARTHQUAKE ZONES OF REQUIRED INVESTIGATION, HOLLYWOOD QUADRANGLE, CALIFORNIA GEOLOGICAL SURVEY, NOVEMBER 6, 2014

EARTHQUAKE ZONES OF REQUIRED INVESTIGATION MAP

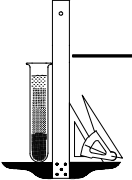

Geotechnologies, Inc.
Consulting Geotechnical Engineers

GRUBB PROPERTIES
1200 N. VINE ST., LOS ANGELES, CA

FILE NO. 22207

BORING LOG NUMBER 1

Grubb Properties

Date: 10/25/21

Elevation: 315.0'*

File No. 22207

Method: 8-inch diameter Hollow Stem Auger

in

***Reference: Land Title Survey by LG Land Surveying, Inc. dated 10/13/20**

Sample Depth ft.	Blows per ft.	Moisture content %	Dry Density p.c.f.	Depth in feet	USCS Class.	Description
				0 --		Surface Conditions: Asphalt for Parking
				-		4-inch Asphalt over 2-inch Base
				1 --		FILL: Sandy Silt, dark brown, moist, stiff
				-		
				2 --		
				-		
2.5	19	19.3	110.6	3 --		
				-		
				4 --	CL	NATIVE SOIL: Silty Clay, dark brown, moist, stiff
				-		
5	15	16.1	SPT	5 --		
				-	SM/ML	Silty Sand to Sandy Silt, dark brown, moist, medium dense, stiff, fine grained
				6 --		
				-		
				7 --		
				-		
7.5	26	11.4	109.5	8 --	SM	Silty Sand, dark brown, moist, medium dense, fine grained, minor pebbles
				-		
				9 --		
				-		
10	13	8.0	SPT	10 --		
				-	SM/SP	Silty Sand to Sand, dark and yellowish brown, moist, medium dense, fine to medium grained
				11 --		
				-		
				12 --		
				-		
12.5	22	10.8	115.5	13 --	SP	Sand, dark brown, moist, medium dense, fine to medium grained
				-		
				14 --		
				-		
15	15	8.7	SPT	15 --		
				-	SP/SM	Silty Sand to Sand, dark brown, moist, medium dense, fine grained
				16 --		
				-		
				17 --		
				-		
17.5	28	18.4	106.5	18 --	ML/CL	Sandy Silt to Silty Clay, dark brown, moist, stiff
				-		
				19 --		
				-		
20	19	12.7	SPT	20 --		
				-	SM/ML	Silty Sand to Sandy Silt, dark brown, moist, medium dense, stiff, fine grained
				21 --		
				-		
				22 --		
				-		
				23 --		
				-		
				24 --		
				-		
25	11	24.6	SPT	25 --		
				-	CL/SC	Silty Clay to Clayey Sand, dark brown, wet, medium dense, stiff, fine grained

BORING LOG NUMBER 1

Grubb Properties

File No. 22207

In

Sample Depth ft.	Blows per ft.	Moisture content %	Dry Density p.c.f.	Depth in feet	USCS Class.	Description
				-		
				26 --		
				-		
27.5	22	17.8	113.5	27 --		
				-		
				28 --		
				-		
				29 --		
				-		
30	21	16.8	SPT	30 --		
				-	SM	Silty Sand, dark brown, very moist, medium dense, fine to medium grained
				31 --		
				-		
32.5	77	14.4	120.2	32 --		
				-		
				33 --		
				-		
				34 --		
				-		
35	31	16.3	SPT	35 --		
				-	SM/SP	Silty Sand to Sand, dark brown, moist, medium dense, fine to medium grained
				36 --		
				-		
				37 --		
				-		
37.5	84	11.9	114.5	38 --	SP	Sand, dark brown, wet, very dense, fine to medium grained
				-		
				39 --		
				-		
40	26	15.2	SPT	40 --		----- medium dense
				-		
				41 --		
				-		
				42 --		
				-		
42.5	70	11.0	123.9	43 --	SP	Sand, dark brown, wet, very dense, fine grained, minor cobbles
				-		
				44 --		
				-		
45	35	15.4	SPT	45 --		----- medium dense
				-		
				46 --		
				-		
				47 --		
				-		
47.5	75	15.6	115.8	48 --	SM/ML	Silty Sand to Sandy Silt with Clay, dark brown, dense, stiff, fine to medium grained
				-		
				49 --		
				-		
50	20	24.9	SPT	50 --	CL	Silty Clay, dark brown, moist, stiff
				-		Total Depth: 50 feet Water at 20 feet Fill To 3 feet

BORING LOG NUMBER 2

Grubb Properties

Date: 10/25/21

Elevation: 312.5'*

File No. 22207

Method: 8-inch diameter Hollow Stem Auger

In

***Reference: Land Title Survey by LG Land Surveying, Inc. dated 10/13/20**

Sample Depth ft.	Blows per ft.	Moisture content %	Dry Density p.c.f.	Depth in feet	USCS Class.	Description
				0 --		Surface Conditions: Asphalt for Parking
				-		4-inch Asphalt over 2-inch Base
				1 --		FILL: Sandy to Clayey Silt, dark brown, moist, stiff
				-		
2.5	30	18.0	114.2	2 --		
				-		
				3 --		ML/CL NATIVE SOILS: Clayey Silt to Silty Clay, dark brown, moist, stiff
				-		
5	31	14.1	113.7	4 --		
				-		
				5 --		
				-		
				6 --		
				-		
				7 --		SM/ML Silty Sand to Sandy Silt, dark brown, moist, medium dense, fine grained
				-		
10	27	11.8	119.3	8 --		
				-		
				9 --		
				-		
				10 --		
				-		
				11 --		SP Sand, dark and yellowish brown, moist, medium dense fine to medium grained
				-		
15	28	5.6	106.6	12 --		
				-		
				13 --		
				-		
				14 --		
				-		
				15 --		SM Silty Sand, dark brown, moist, medium dense, fine grained
				-		
20	27	15.1	116.0	16 --		
				-		
				17 --		
				-		
				18 --		
				-		
				19 --		ML/CL Sandy Silt to Silty Clay, dark brown, moist, stiff
				-		
25	16	20.1	110.9	20 --		
				-		
				21 --		
				-		

BORING LOG NUMBER 2

Grubb Properties

File No. 22207

In

Sample Depth ft.	Blows per ft.	Moisture content %	Dry Density p.c.f.	Depth in feet	USCS Class.	Description			
30	81	14.8	120.9	-					
				26 --					
				-					
				27 --					
				-					
				28 --					
				-					
				29 --					
				-					
				30 --					
					ML	Sandy to Clayey Silt, dark and grayish brown, moist, stiff			
				-		Total Depth: 30 feet			
				31 --		Water At 21.5 feet			
				-		Fill To 3 feet			
				32 --					
				-		NOTE: The stratification lines represent the approximate boundary between earth types; the transition may be gradual.			
				33 --					
				-					
				34 --		Used 8-inch diameter Hollow-Stem Auger			
				-		140-lb. Automatic Hammer, 30-inch drop			
				35 --		Modified California Sampler used unless otherwise noted			
				-					
				36 --					
				-					
				37 --					
				-					
38 --									
-									
39 --									
-									
40 --									
-									
41 --									
-									
42 --									
-									
43 --									
-									
44 --									
-									
45 --									
-									
46 --									
-									
47 --									
-									
48 --									
-									
49 --									
-									
50 --									
-									

**BULK SAMPLE REMOLDED TO 90 PERCENT
OF THE MAXIMUM LABORATORY DENSITY**

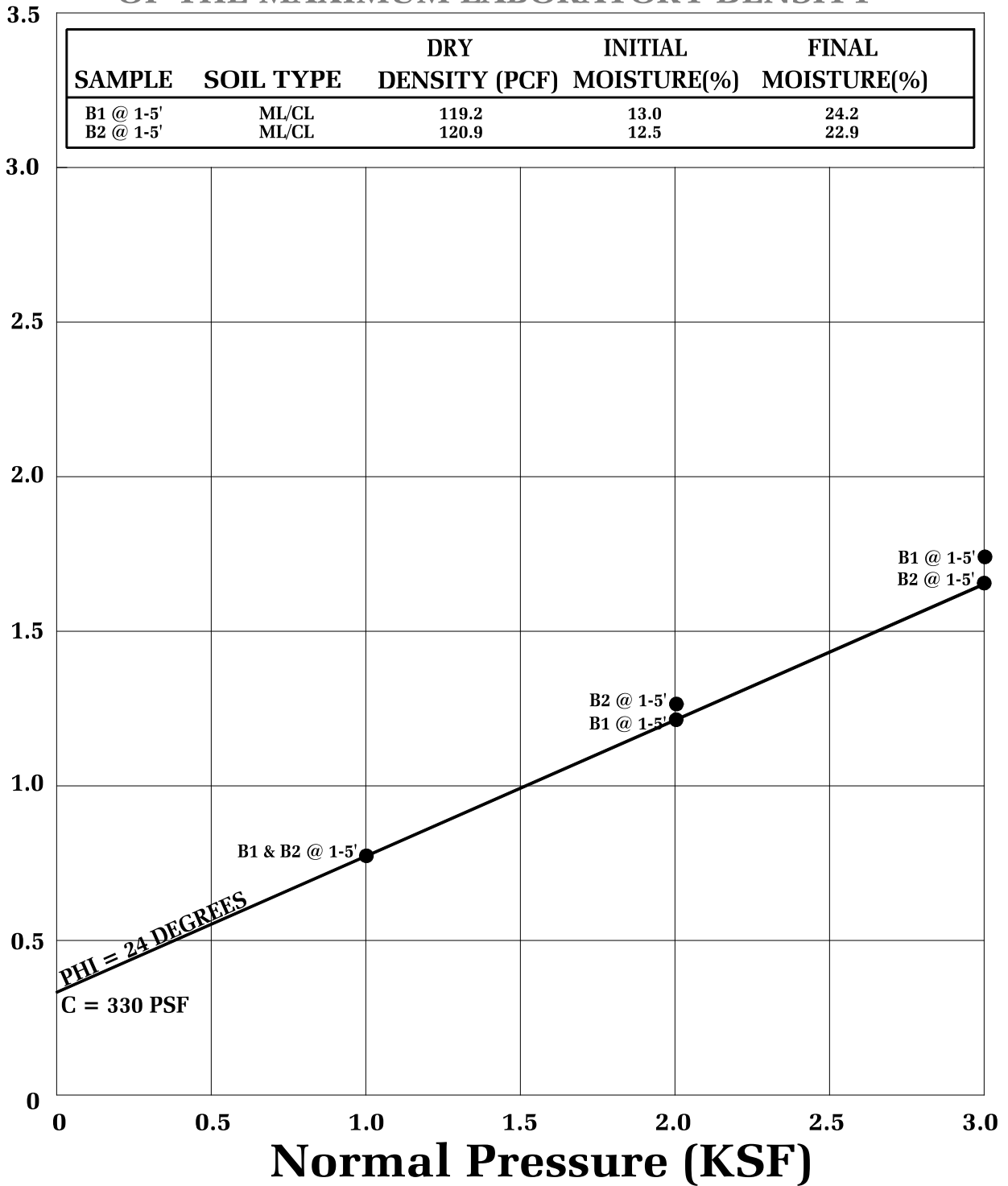

SHEAR TEST DIAGRAM

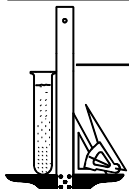

Geotechnologies, Inc.
Consulting Geotechnical Engineers

GRUBB PROERTIES
1200 NORTH VINE STREET, LOS ANGELES

FILE NO. 22207

PLATE: B-1

SAMPLE	SOIL TYPE	DRY DENSITY (PCF)	INITIAL MOISTURE(%)	FINAL MOISTURE(%)
B2 @ 5'	ML/CL	113.7	14.1	16.3
B1 @ 7.5'	SC	109.5	11.4	17.1
B2 @ 10'	SM/ML	119.3	11.8	18.5
B1 @ 12.5'	SP/SC	115.5	10.8	14.0
B2 @ 15'	SP/SC	106.6	5.6	18.8
B2 @ 20'	SC	116.0	15.1	20.5

Shear Strength (KSF)

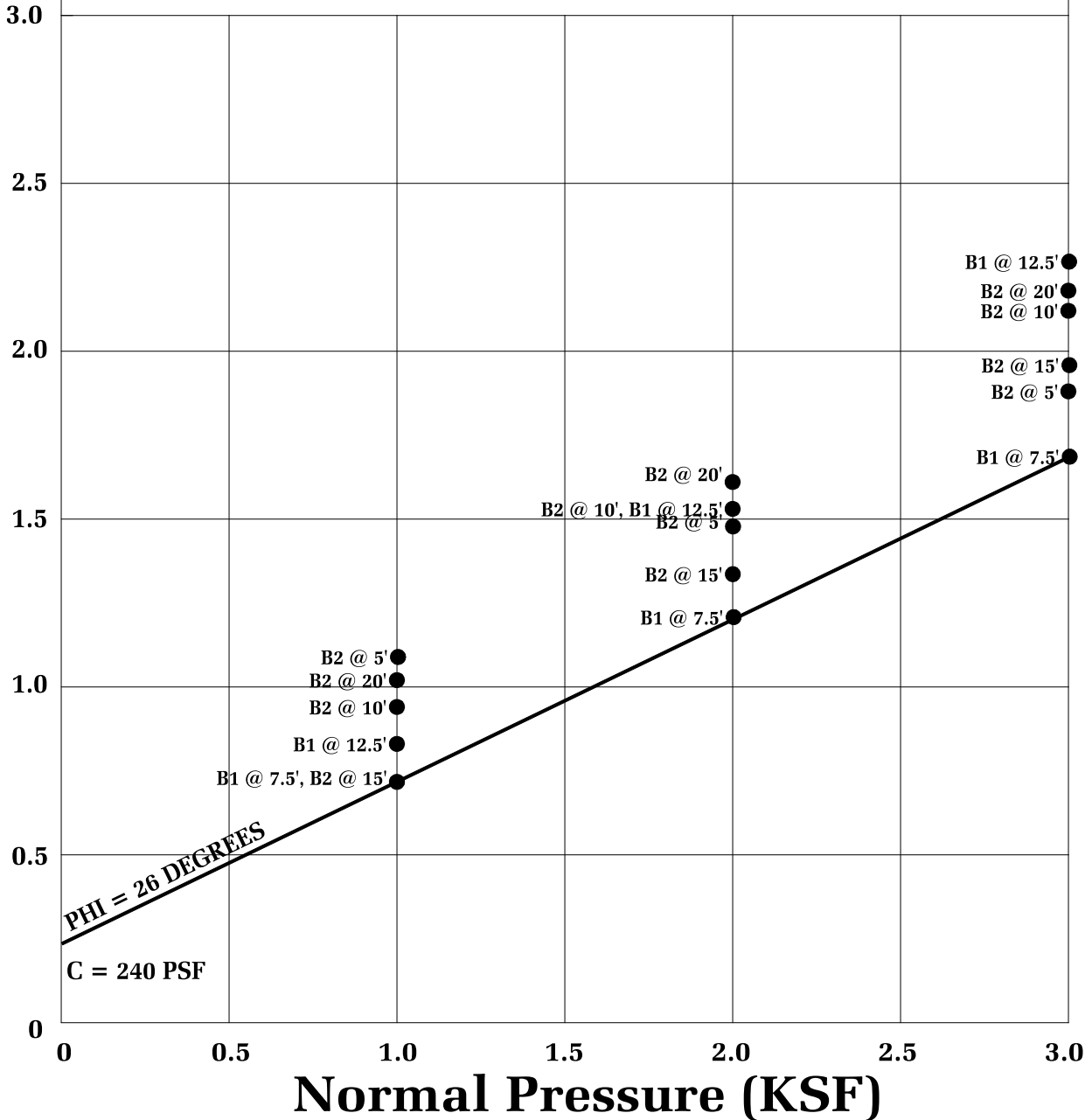

● Direct Shear, Saturated

SHEAR TEST DIAGRAM

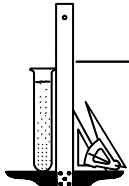

Geotechnologies, Inc.
Consulting Geotechnical Engineers

GRUBB PROPERTIES
1200 NORTH VINE STREET, LOS ANGELES

FILE NO. 22207

PLATE: B-2

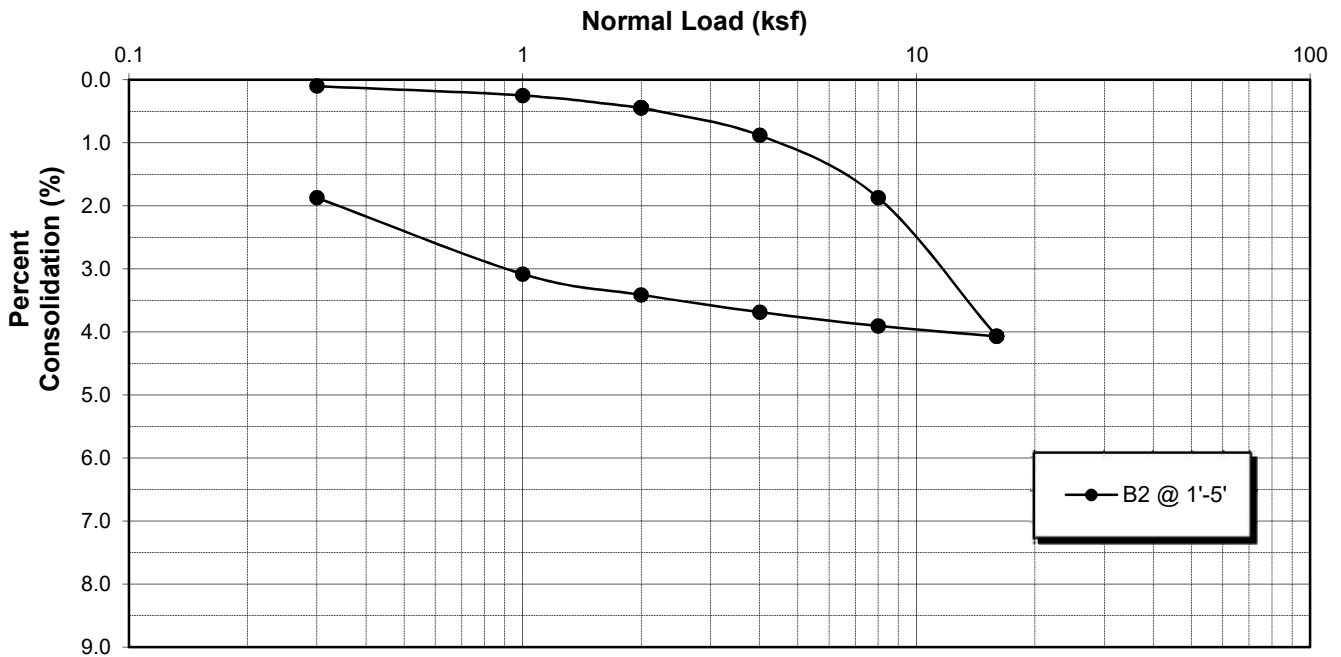
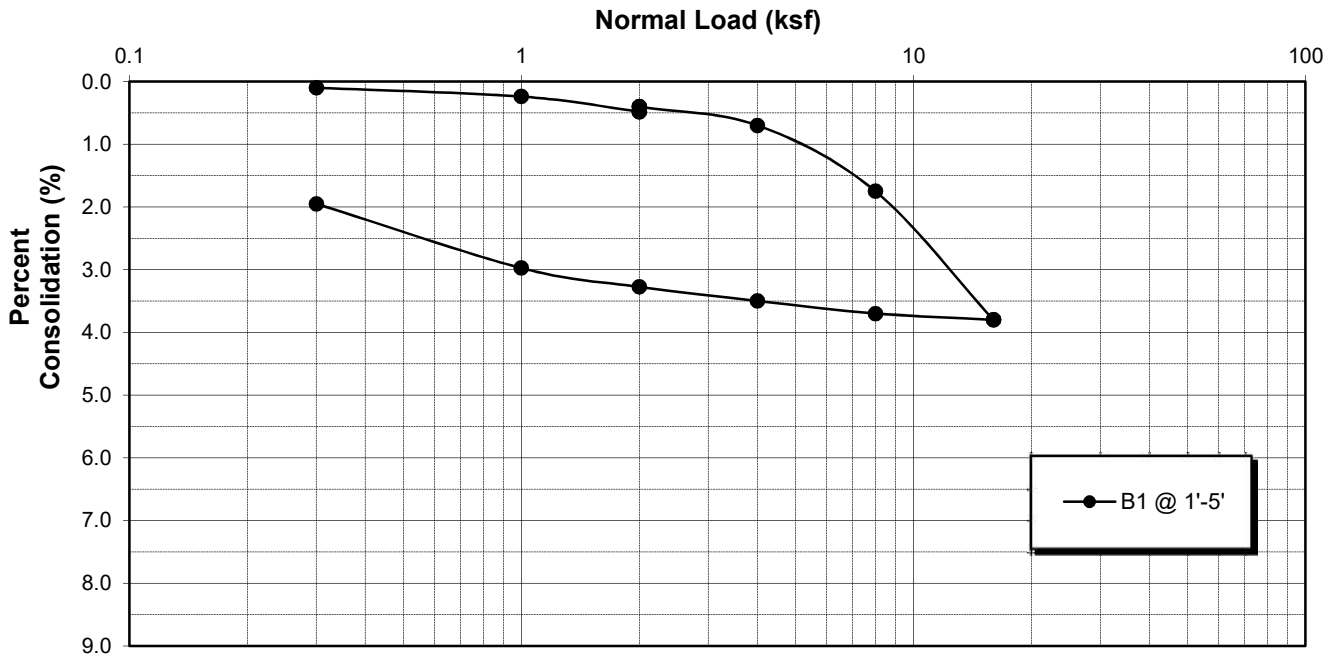

Water added at 2 KSF

CONSOLIDATION

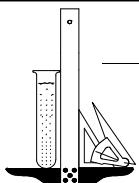

Geotechnologies, Inc.
Consulting Geotechnical Engineers

PROJECT: GRUBB PROPERTIES

FILE NO.: 22207

PLATE: C-1

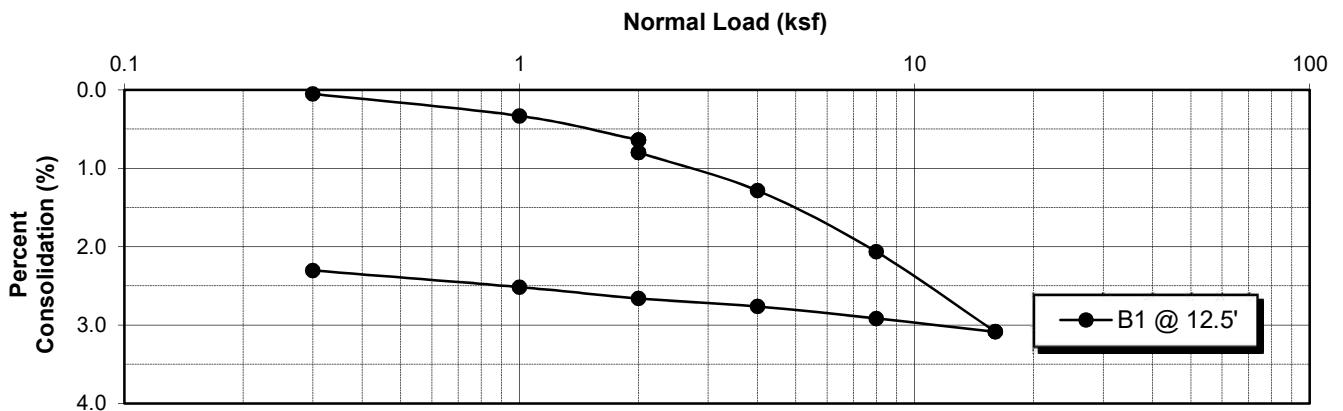
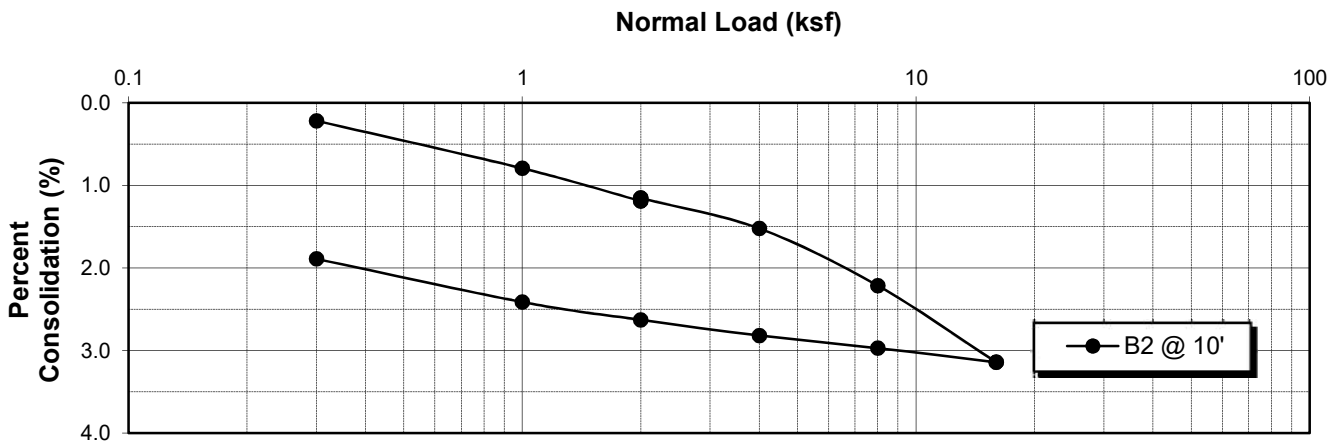
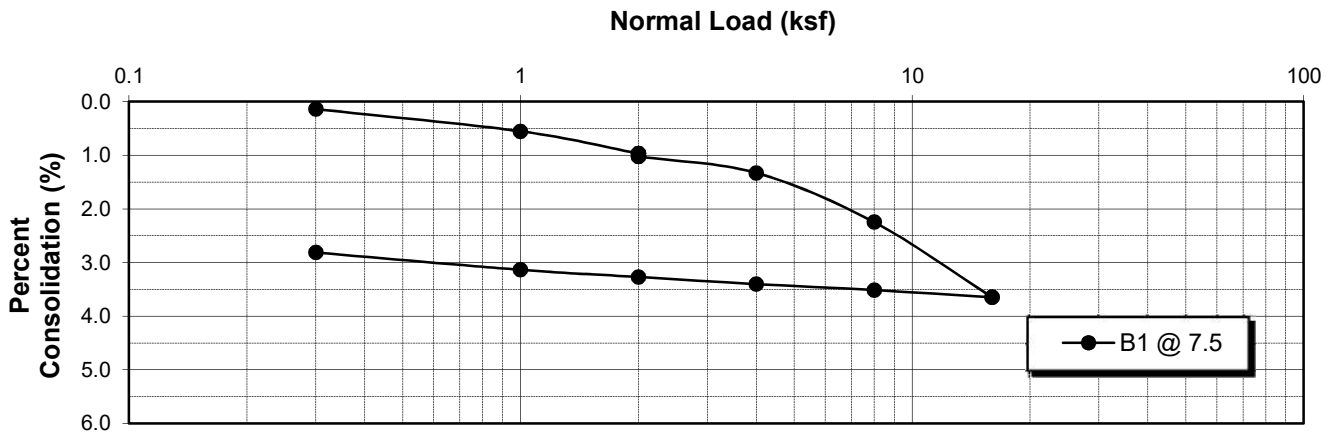

Water added at 2 KSF

CONSOLIDATION

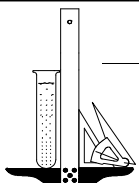

Geotechnologies, Inc.
Consulting Geotechnical Engineers

PROJECT: GRUBB PROPERTIES

FILE NO.: 22207

PLATE: C-2

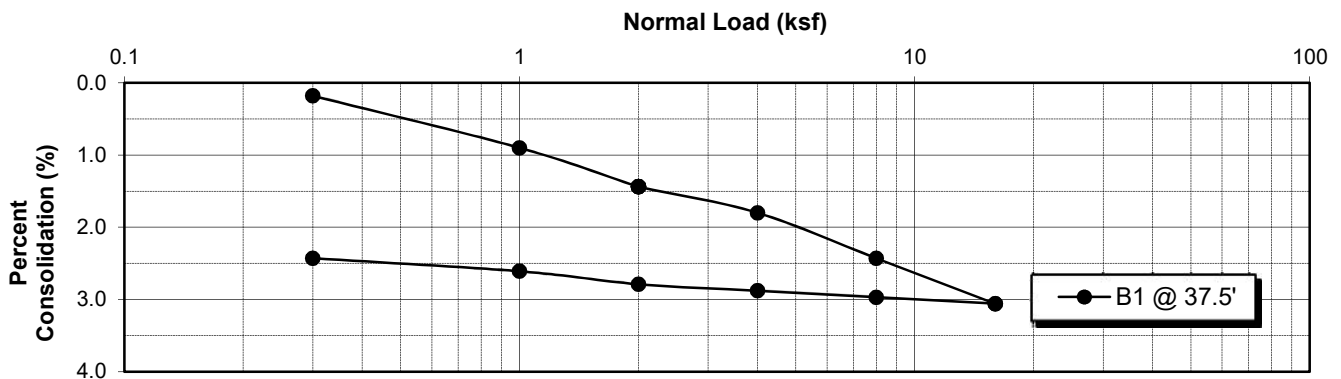
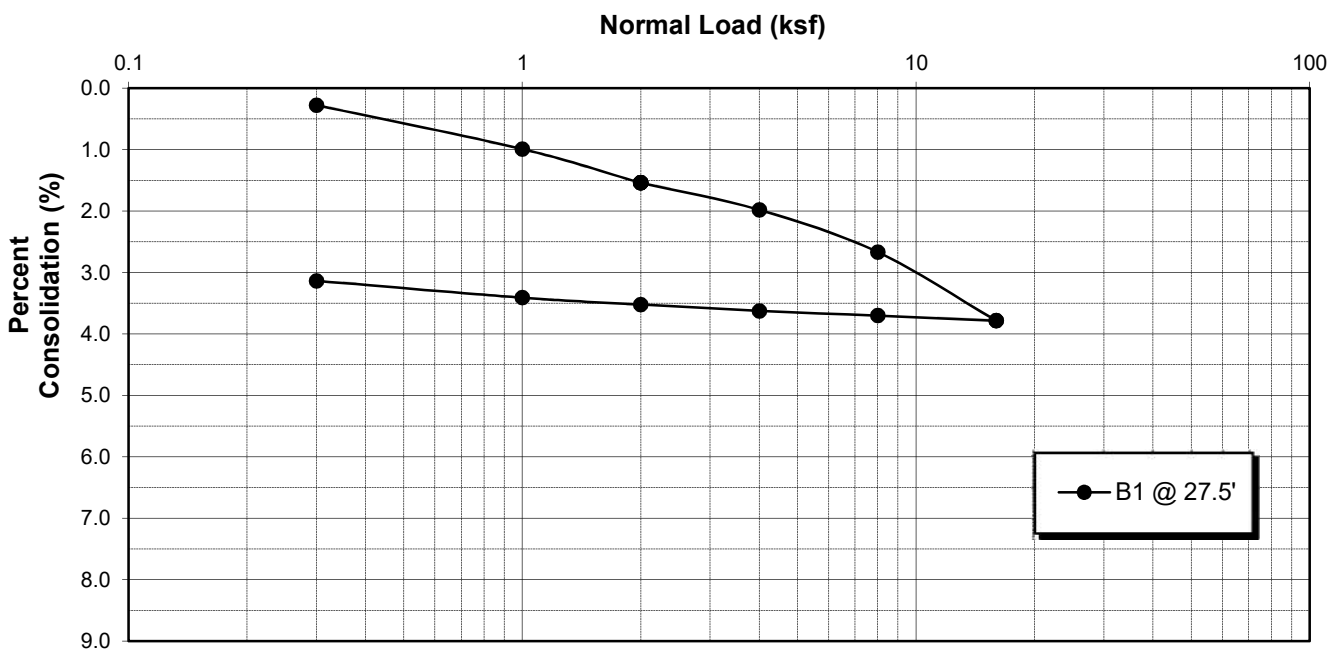
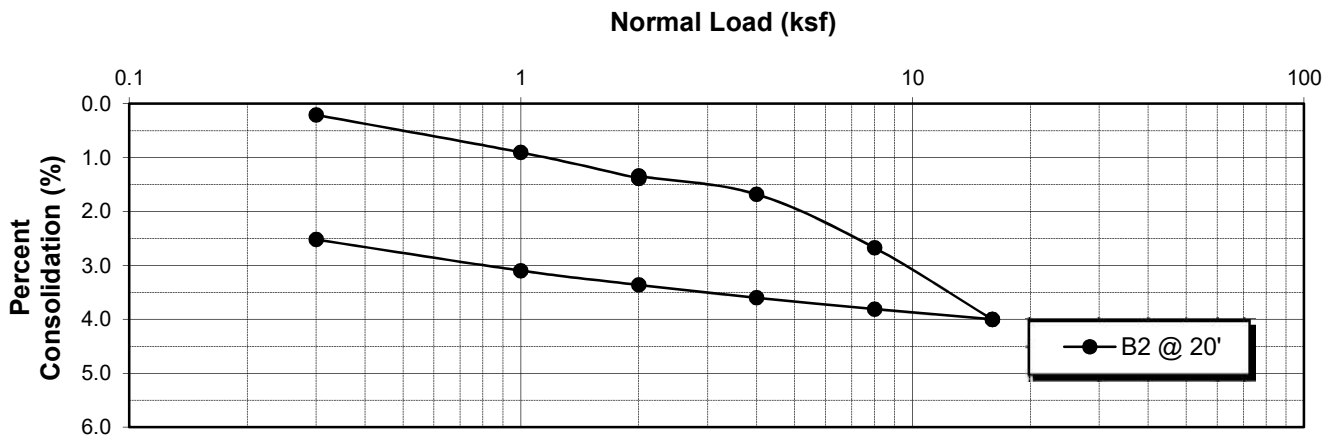

Water added at 2 KSF

CONSOLIDATION

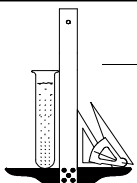

Geotechnologies, Inc.
Consulting Geotechnical Engineers

PROJECT: GRUBB PROPERTIES

FILE NO.: 22207

PLATE: C-3

ASTM D-1557		
SAMPLE	B1 @ 1'-5'	B2 @ 1'-5'
SOIL TYPE	ML/CL	ML/CL
MAXIMUM DENSITY PCF.	119.2	120.9
OPTIMUM MOISTURE %	13	12.5

ASTM D 4829		
SAMPLE	B1 @ 1'-5'	B2 @ 1'-5'
SOIL TYPE	ML/CL	ML/CL
EXPANSION INDEX UBC STANDARD 18-2	94	106
EXPANSION CHARACTER	<u>HIGH</u>	<u>HIGH</u>

SULFATE CONTENT		
SAMPLE	B1 @ 1'-5'	B2 @ 1'-5'
SULFATE CONTENT: (PERCENTAGE BY WEIGHT)	<0.1%	<0.1%

COMPACTION/EXPANSION/SULFATE DATA SHEET

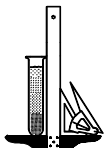

Geotechnologies, Inc.
Consulting Geotechnical Engineers

GRUBB PROPERTIES
1200 NORTH VINE STREET, LOS ANGELES

FILE NO. 22207

PLATE: D-1

GRAVEL	SAND		SILT	CLAY
	MEDIUM TO COARSE	FINE		

U.S. Standard Sieve Sizes

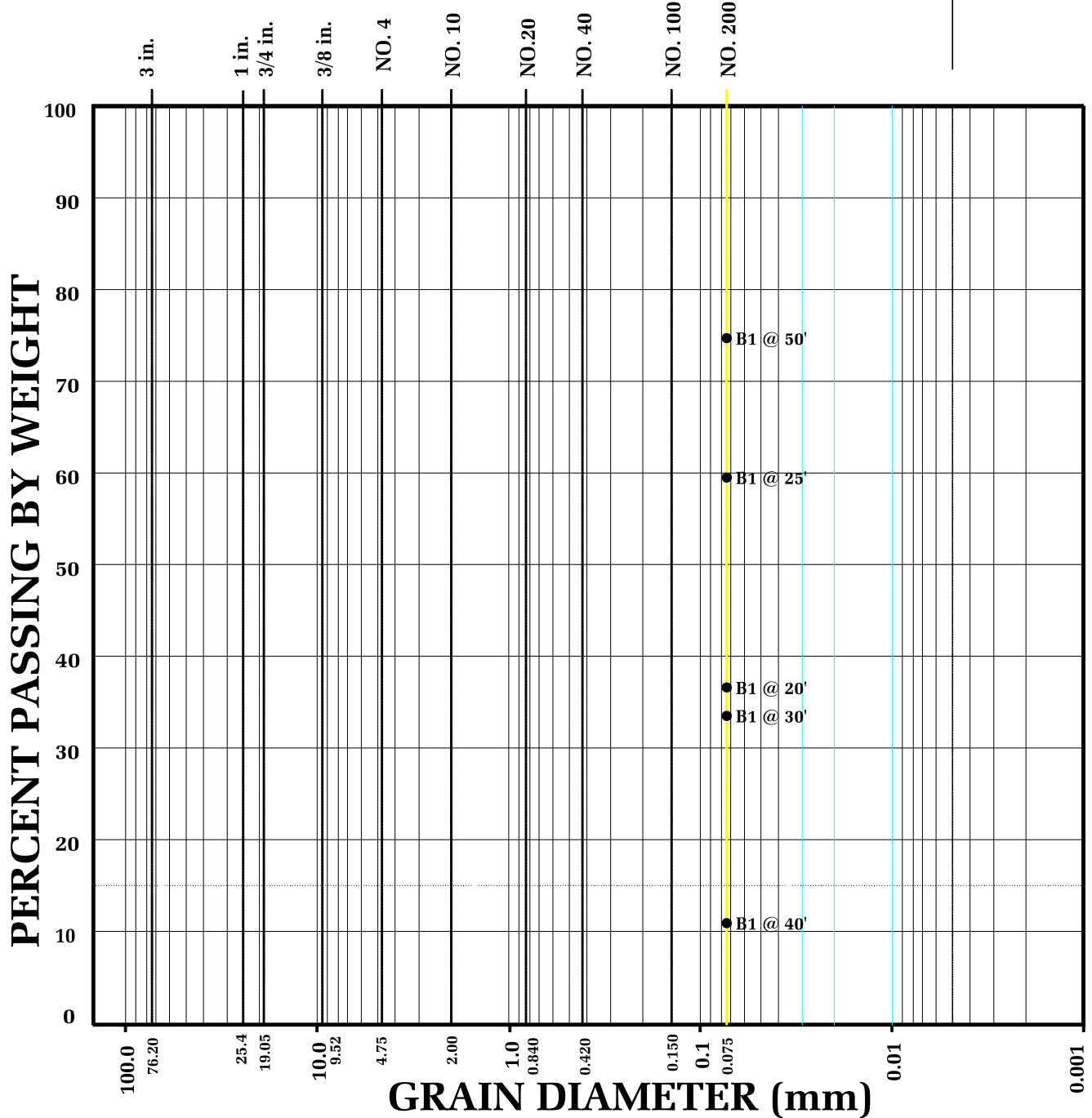

GRAIN SIZE DISTRIBUTION

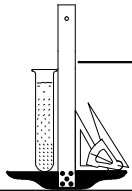

Geotechnologies, Inc.
Consulting Geotechnical Engineers

GRUBB PROPERTIES
1200 NORTH VINE STREET, LOS ANGELES

FILE NO. 22207

PLATE: E

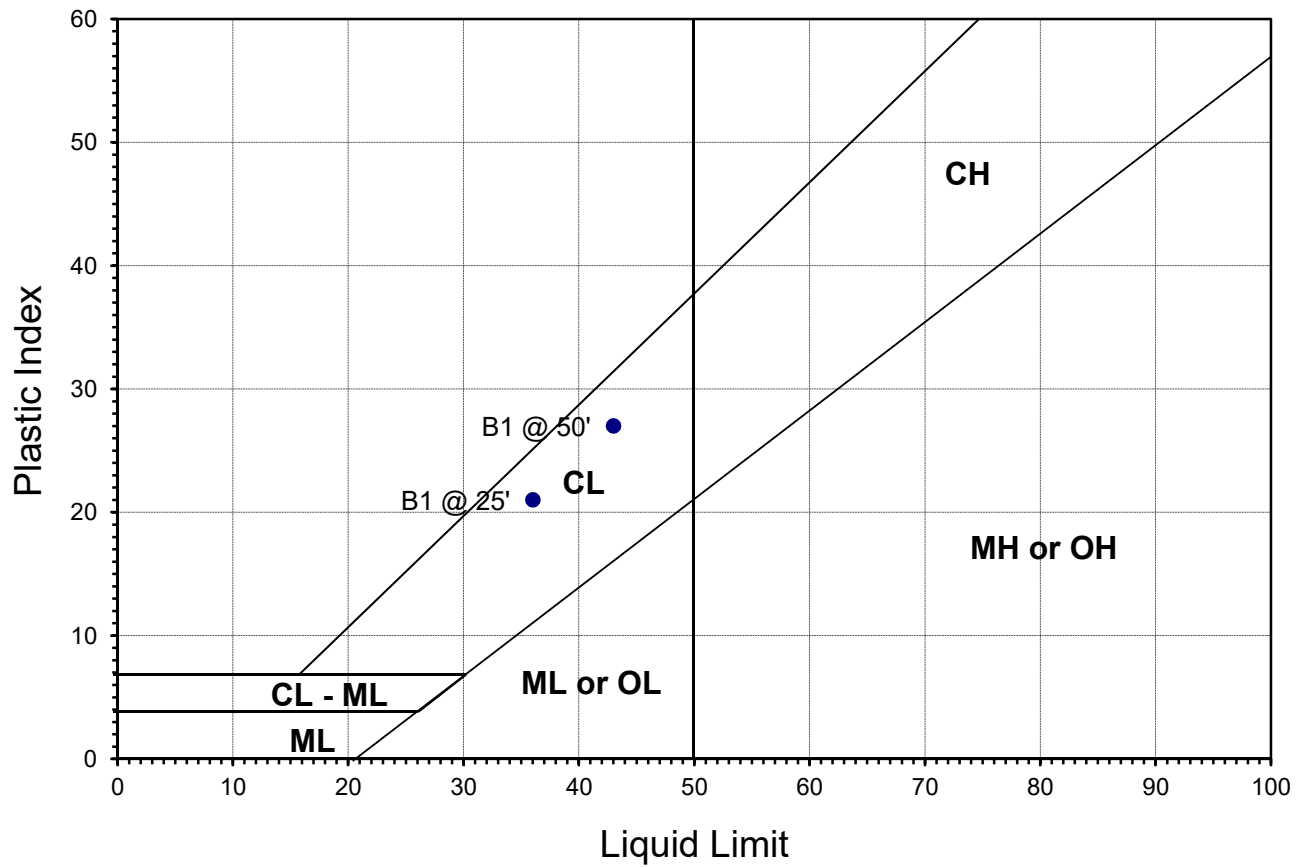

Sample ID	Descriptions	Passing #200	Liquid Limit	Plastic Limit	Plastic Index
B1 @ 25'	CL	59.5	36.0	15.0	21.0
B1 @ 50'	CL	74.7	43.0	16.0	27.0
0	0	0.0	0.0	0.0	0.0
0	0	0.0	0.0	0.0	0.0
0	0	0.0	0.0	0.0	0.0
0	0	0.0	0.0	0.0	0.0
0	0	0.0	0.0	0.0	0.0
0	0	0.0	0.0	0.0	0.0
0	0	0.0	0.0	0.0	0.0
0	0	0.0	0.0	0.0	0.0

ATTERBERG LIMITS

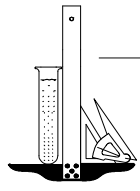

Geotechnologies, Inc.
CONSULTING GEOTECHNICAL ENGINEERS

PROJECT: GRUBB PROPERTIES

FILE NO.: 22207

PLATE: F-1



Geotechnologies, Inc.

Project: Grubb Properties

File No.: 22207

Settlement Calculation - Column Footing

Description: Column footing bearing in compacted fill

Soil Unit Weight	120.0 pcf	Column Footing
Bearing Value	5000.0 psf	690 kips
Depth of Footing	3.0 feet	
Width of Footing	11.75 feet	

* Influence Values are based on Westergaard's Analyses (Ref: Sowers)

Depth Below Basement Subgrade (feet)	Average Depth Below Ground Surface (feet)	Average Depth Below Foundation (feet)	Ratio of Foundation vs. Depth (a/z)	Influence Value	Foundation Influence Pressure (psf)	Natural Soil Pressure (psf)	Total Pressure (psf)	Consolidation Curve Used	Percent Strain [Total] (%)	Percent Strain [Natural] (%)	Percent Strain [Net] (%)	Thickness of Depth Increment (feet)	Net Settlement (inches)
3.0													
	4.5	1.5	7.8	83%	4153.875	540	4693.875	B1 @ 1-5'	0.80	0.25	0.55	3.0	0.20
6.0													
	8.0	5.0	2.4	50%	2493.75	960	3453.75	B1 @ 7.5'	1.25	0.60	0.65	4.0	0.31
10.0													
	12.5	9.5	1.2	29%	1429	1500	2929	B1 @ 12.5'	1.05	0.50	0.55	5.0	0.33
15.0													
	21.3	18.3	0.6	10%	499.5	2550	3049.5	B2 @ 20'	1.50	1.40	0.10	12.5	0.15
27.5													

Settlement: 0.99

Total Settlement in inches: 0.99

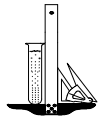

Geotechnologies, Inc.

Project: Grubb Properties
 File No.: 22207

Settlement Calculation - Column Footing

Description: Column footing bearing in native soils

Soil Unit Weight	120.0 pcf	Column Footing
Bearing Value	5000.0 psf	690 kips
Depth of Footing	3.0 feet	
Width of Footing	11.75 feet	

* Influence Values are based on Westergaard's Analyses (Ref: Sowers)

Depth Below Basement Subgrade (feet)	Average Depth Below Ground Surface (feet)	Average Depth Below Foundation (feet)	Ratio of Foundation vs. Depth (a/z)	Influence Value	Foundation Influence Pressure (psf)	Natural Soil Pressure (psf)	Total Pressure (psf)	Consolidation Curve Used	Percent Strain [Total] (%)	Percent Strain [Natural] (%)	Percent Strain [Net] (%)	Thickness of Depth Increment (feet)	Net Settlement (inches)
3.0													
	6.5	3.5	3.4	63%	3154.5	780	3934.5	B1 @ 7.5'	1.30	0.55	0.75	7.0	0.63
10.0													
	12.5	9.5	1.2	29%	1429	1500	2929	B1 @ 12.5'	1.07	0.52	0.55	5.0	0.33
15.0													
	21.3	18.3	0.6	10%	499.5	2550	3049.5	B2 @ 20'	1.50	1.47	0.03	12.5	0.05
27.5													

Settlement: 1.01

Total Settlement in inches: 1.01

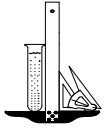

Geotechnologies, Inc.

Project: **Grubb Properties**

File No.: **22207**

Description: **Drained Catilever Retaining Wall (up to 6 feet)**

Retaining Wall Design with Level Backfill (Vector Analysis)

Input:
 Retaining Wall Height (H) **6.00** feet
 Unit Weight of Retained Soils (γ) **120.0** pcf
 Friction Angle of Retained Soils (ϕ) **26.0** degrees
 Cohesion of Retained Soils (c) **240.0** psf
 Factor of Safety (FS) **1.50**
 Factored Parameters: (ϕ_{FS}) **18.0** degrees
84.2 160.0 psf

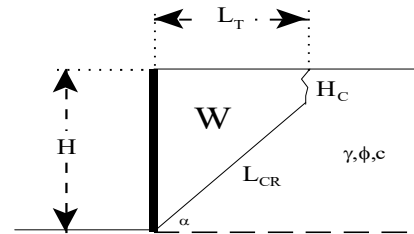

Failure Angle (α) degrees	Height of Tension Crack (H_C) feet	Area of Wedge (A) feet ²	Weight of Wedge (W) lbs/lineal foot	Length of Failure Plane (L_{CR}) feet	Failure Plane		Active Pressure (P_A) lbs/lineal foot
					a lbs/lineal foot	b lbs/lineal foot	
40	4.4	10	1176.6	2.5	998.3	178.3	72.0
41	4.3	10	1207.4	2.6	1008.4	199.0	84.4
42	4.2	10	1225.1	2.7	1008.5	216.6	96.4
43	4.1	10	1232.5	2.8	1001.2	231.2	107.8
44	4.0	10	1231.3	2.8	988.4	242.9	118.4
45	4.0	10	1223.1	2.9	971.4	251.8	128.2
46	3.9	10	1209.3	2.9	951.2	258.1	137.1
47	3.8	10	1190.7	3.0	928.8	261.9	145.1
48	3.8	10	1168.3	3.0	904.8	263.5	152.1
49	3.8	10	1142.7	3.0	879.5	263.1	158.0
50	3.7	9	1114.3	3.0	853.5	260.8	162.9
51	3.7	9	1083.7	3.0	826.9	256.9	166.7
52	3.7	9	1051.3	2.9	799.9	251.4	169.5
53	3.7	8	1017.2	2.9	772.7	244.5	171.1
54	3.7	8	981.8	2.9	745.4	236.4	171.7
55	3.7	8	945.2	2.8	718.0	227.2	171.2
56	3.7	8	907.7	2.8	690.6	217.1	169.5
57	3.7	7	869.2	2.7	663.1	206.1	166.8
58	3.7	7	829.9	2.7	635.6	194.3	163.0
59	3.8	7	789.9	2.6	608.0	181.9	158.1
60	3.8	6	749.3	2.6	580.2	169.1	152.2
61	3.8	6	708.0	2.5	552.2	155.8	145.2
62	3.9	6	666.0	2.4	523.8	142.2	137.2
63	4.0	5	623.4	2.3	495.0	128.4	128.3
64	4.0	5	580.1	2.2	465.6	114.5	118.5
65	4.1	4	536.2	2.1	435.5	100.7	107.9

Design Equations (Vector Analysis):
 $a = c_{FS} * L_{CR} * \sin(90 + \phi_{FS}) / \sin(\alpha - \phi_{FS})$
 $b = W - a$
 $P_A = b * \tan(\alpha - \phi_{FS})$
 $EFP = 2 * P_A / H^2$

Maximum Active Pressure Resultant

$$P_{A, \max}$$

171.7 | lbs/lineal foot

Equivalent Fluid Pressure (per lineal foot of wall)

$$EFP = 2 * P_A / H^2$$

EFP

9.5 pcf

Design Wall for an Equivalent Fluid Pressure:

45 pcf

(High E.I.)



Geotechnologies, Inc.

Project: Grubb Properties

File No.: 22207

Description: Drained Catilever Retaining Wall (up to 6 feet)

Retaining Wall Design with Level Backfill (Vector Analysis)

Input:

Retaining Wall Height (H) 6.00 feet

Unit Weight of Retained Soils (γ) 57.6 pcf

Friction Angle of Retained Soils (ϕ) 26.0 degrees

Cohesion of Retained Soils (c) 240.0 psf

Factor of Safety (FS) 1.50

Factored Parameters: (ϕ_{FS}) 18.0 degrees

84.2 160.0 psf

(Buoyant)

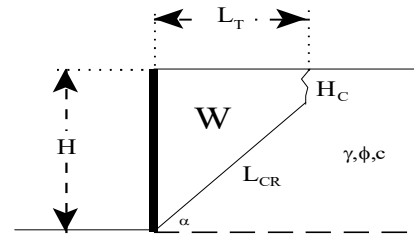

Failure Angle (α) degrees	Height of Tension Crack (H_C) feet	Area of Wedge (A) feet ²	Weight of Wedge (W) lbs/lineal foot	Length of Failure Plane (L_{CR}) feet	a		b		Active Pressure (P_A) lbs/lineal foot
					lbs/lineal foot	lbs/lineal foot	lbs/lineal foot	lbs/lineal foot	
40	9.2	-29	-1675.9	-5.0	-2029.7	353.7	0.0	0.0	
41	9.0	-25	-1468.6	-4.5	-1759.4	290.8	0.0	0.0	
42	8.7	-22	-1293.9	-4.1	-1534.7	240.8	0.0	0.0	
43	8.6	-20	-1146.2	-3.7	-1347.1	200.9	0.0	0.0	
44	8.4	-18	-1021.1	-3.4	-1190.2	169.0	0.0	0.0	
45	8.2	-16	-915.0	-3.2	-1058.5	143.5	0.0	0.0	
46	8.1	-14	-825.0	-2.9	-948.1	123.0	0.0	0.0	
47	8.0	-13	-748.8	-2.7	-855.4	106.6	0.0	0.0	
48	7.9	-12	-684.3	-2.6	-777.8	93.5	0.0	0.0	
49	7.8	-11	-630.0	-2.4	-713.0	83.0	0.0	0.0	
50	7.8	-10	-584.5	-2.3	-659.1	74.7	0.0	0.0	
51	7.7	-9	-546.6	-2.2	-614.8	68.2	0.0	0.0	
52	7.7	-9	-515.6	-2.1	-578.7	63.2	0.0	0.0	
53	7.7	-9	-490.5	-2.1	-549.9	59.5	0.0	0.0	
54	7.6	-8	-470.7	-2.0	-527.6	56.8	0.0	0.0	
55	7.7	-8	-455.7	-2.0	-510.9	55.2	0.0	0.0	
56	7.7	-8	-445.0	-2.0	-499.5	54.5	0.0	0.0	
57	7.7	-8	-438.2	-2.0	-492.9	54.6	0.0	0.0	
58	7.8	-8	-435.1	-2.1	-490.6	55.6	0.0	0.0	
59	7.8	-8	-435.2	-2.1	-492.5	57.3	0.0	0.0	
60	7.9	-8	-438.5	-2.2	-498.4	59.9	0.0	0.0	
61	8.0	-8	-444.8	-2.3	-508.1	63.3	0.0	0.0	
62	8.1	-8	-453.9	-2.4	-521.6	67.7	0.0	0.0	
63	8.2	-8	-465.8	-2.5	-538.8	73.0	0.0	0.0	
64	8.4	-8	-480.5	-2.6	-560.0	79.5	0.0	0.0	
65	8.5	-9	-497.9	-2.8	-585.1	87.2	0.0	0.0	

Design Equations (Vector Analysis):
 $a = c_{FS} * L_{CR} * \sin(90 + \phi_{FS}) / \sin(\alpha - \phi_{FS})$
 $b = W - a$
 $P_A = b * \tan(\alpha - \phi_{FS})$
 $EFP = 2 * P_A / H^2$

Maximum Active Pressure Resultant

$P_{A, max}$

0.0 | lbs/lineal foot

Equivalent Fluid Pressure (per lineal foot of wall)

$EFP = 2 * P_A / H^2$

EFP

0.0 pcf

Design Wall for an Equivalent Fluid Pressure:

98 pcf

(Includes Hydrostatic Pressure)

Geotechnologies, Inc.

Project: Grubb Properties
File No.: 22207

DRAINED RESTRAINED RETAINING WALL

Soil Weight	γ	120 pcf
Internal Friction Angle	ϕ	26 degrees
Cohesion	c	0 psf
Height of Retaining Wall	H	6 feet

Restrained Retaining Wall Design based on At Rest Earth Pressure

$$\sigma'_h = K_o \sigma'_v$$

$$K_o = 1 - \sin\phi \quad 0.562$$

$$\sigma'_v = \gamma H \quad 720.0 \text{ psf}$$

$$\sigma'_h = 404.4 \text{ psf}$$

$$\text{EFP} = 67.4 \text{ pcf}$$

$$P_o = 1213.1 \text{ lbs/ft} \quad (\text{based on a triangular distribution of pressure})$$

Design wall for an EFP of 68 pcf

Geotechnologies, Inc.

Project: Grubb Properties
File No.: 22207

UNDRAINED RESTRAINED RETAINING WALL

Soil Weight	γ	57.6 pcf	(Buoyant)
Internal Friction Angle	ϕ	26 degrees	
Cohesion	c	0 psf	
Height of Retaining Wall	H	6 feet	

Restrained Retaining Wall Design based on At Rest Earth Pressure

$$\sigma'_h = K_o \sigma'_v$$

$$K_o = 1 - \sin\phi \quad 0.562$$

$$\sigma'_v = \gamma H \quad 345.6 \text{ psf}$$

$$\sigma'_h = 194.1 \text{ psf}$$

$$\text{EFP} = 32.3 \text{ pcf}$$

$$P_o = 582.3 \text{ lbs/ft} \quad (\text{based on a triangular distribution of pressure})$$

Design wall for an EFP of 93 pcf (Includes Hydrostatic Pressure)

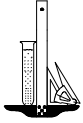

Geotechnologies, Inc.

Project: GRUBB PROPERTIES
 File No.: 22207
 Description: Slot Cut

Slot Cut Calculation

Input:

Height of Slots (H) 7 feet
 Unit Weight of Soils (γ) 120.0 pcf
 Friction Angle of Soils (ϕ) 26.0 degrees
 Cohesion of Soils (c) 240.0 psf
 Factor of Safety (FS) 1.25
 Factor of Safety = Resistance Force/Driving Force
 Coefficient of Lateral Earth Pressure At-Rest (K_0) 0.5
 Surcharge Pressure:
 Line Load (q_L) 2500.0 plf
 Distance Away from Edge of Excavation (X) 0.0 feet

Design Equations

$$b = H/(\tan \alpha)$$

$$A = 0.5 * H * b$$

$$W = 0.5 * H * b * \gamma \text{ (per lineal foot of slot width)}$$

$$F_1 = d * W * (\sin \alpha) * (\cos \alpha)$$

$$F_2 = d * L$$

$$R_1 = d * [W * (\cos^2 \alpha) * (\tan \phi) + (c * b)]$$

$$R_2 = 2 * \Delta F$$

$$\Delta F = A * [1/3 * \gamma * H * K_0 * (\tan \phi) + c]$$

$$FS = \text{Resistance Force/Driving Force}$$

$$FS = (R_1 + R_2) / (F_1 + F_2)$$

Failure Angle (α) degrees	Base Width of Failure Wedge (b) feet	Area of Failure Wedge (A) feet ²	Weight of Failure Wedge (W) lbs/lineal foot	Driving Force Wedge + Surcharge per lineal foot of Slot Width	Resisting Force Failure Wedge per lineal foot of Slot Width	Resisting Force Side Resistance Force (ΔF) lbs	Allowable Width of Slots* (d) feet
60	4.0	14	1697.4	1817.5	1481.8	4438.0	11.4
61	3.9	14	1629.7	1751.1	1404.7	4260.8	11.0
62	3.7	13	1563.2	1684.3	1330.1	4087.1	10.7
63	3.6	12	1498.0	1617.2	1257.9	3916.6	10.4
64	3.4	12	1433.9	1550.0	1188.1	3749.1	10.1
65	3.3	11	1370.9	1482.7	1120.6	3584.4	9.9
66	3.1	11	1309.0	1415.3	1055.3	3422.4	9.7
67	3.0	10	1248.0	1348.0	992.2	3262.8	9.5
68	2.8	10	1187.8	1280.9	931.2	3105.7	9.4
69	2.7	9	1128.6	1214.0	872.2	2950.7	9.2
70	2.5	9	1070.1	1147.4	815.2	2797.8	9.1
71	2.4	8	1012.3	1081.2	760.0	2646.8	9.0
72	2.3	8	955.3	1015.5	706.8	2497.6	9.0
73	2.1	7	898.8	950.3	655.3	2350.1	8.9
74	2.0	7	843.0	885.8	605.6	2204.1	8.9
75	1.9	7	787.8	821.9	557.6	2059.7	8.8
76	1.7	6	733.0	758.9	511.2	1916.5	8.8
77	1.6	6	678.8	696.7	466.3	1774.6	8.8
78	1.5	5	624.9	635.5	423.0	1633.9	8.9
79	1.4	5	571.5	575.3	381.1	1494.2	8.9
80	1.2	4	518.4	516.2	340.6	1355.4	9.0
81	1.1	4	465.7	458.2	301.5	1217.5	9.1
82	1.0	3	413.2	401.5	263.6	1080.3	9.1
83	0.9	3	361.0	346.1	227.0	943.8	9.3
84	0.7	3	309.0	292.0	191.5	807.9	9.4
85	0.6	2	257.2	239.4	157.2	672.5	9.5

Critical Slot Width with Factor of Safety equal or exceeding 1.5:

d_{allow}

8.8 feet

The proposed excavation may be made using the **A-B-C** Slot-Cutting Method with a Maximum Allowable Slot Width of **8** Feet, and up to **7** Feet in Height, with a Factor of Safety Equal or Exceeding 1.25.

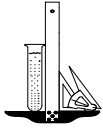

Geotechnologies, Inc.

Project: **Grubb Properties**

File No.: **22207**

Description: **Temporary Shoring (up to 10 feet)**

Shoring Design with Level Backfill (Vector Analysis)

Input:
 Shoring Height (H) **10.00** feet
 Unit Weight of Retained Soils (γ) **120.0** pcf
 Friction Angle of Retained Soils (ϕ) **26.0** degrees
 Cohesion of Retained Soils (c) **240.0** psf
 Factor of Safety (FS) **1.25**
 Factored Parameters: (ϕ_{FS}) **21.3** degrees
84.2 192.0 psf

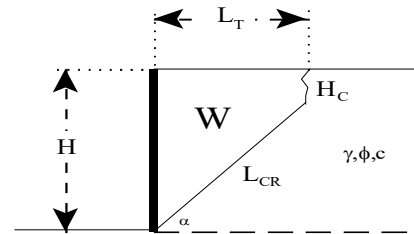

Failure Angle (α) degrees	Height of Tension Crack (H_C) feet	Area of Wedge (A) feet ²	Weight of Wedge (W) lbs/lineal foot	Length of Failure Plane (L_{CR}) feet	Active Pressure (P_A) lbs/lineal foot		
					a	b	
40	6.1	38	4512.8	6.1	3410.4	1102.3	372.8
41	5.9	38	4529.4	6.3	3348.3	1181.2	422.6
42	5.7	38	4515.1	6.5	3270.5	1244.6	469.9
43	5.5	37	4476.7	6.6	3182.9	1293.8	514.5
44	5.4	37	4419.6	6.7	3089.3	1330.3	556.1
45	5.2	36	4347.8	6.7	2992.6	1355.2	594.5
46	5.1	36	4264.6	6.8	2894.9	1369.7	629.6
47	5.0	35	4172.4	6.8	2797.3	1375.1	661.3
48	5.0	34	4073.2	6.8	2701.0	1372.1	689.7
49	4.9	33	3968.5	6.8	2606.6	1361.9	714.6
50	4.8	32	3859.6	6.7	2514.4	1345.1	736.0
51	4.8	31	3747.3	6.7	2424.8	1322.6	753.9
52	4.7	30	3632.6	6.7	2337.7	1294.9	768.4
53	4.7	29	3516.0	6.6	2253.3	1262.7	779.4
54	4.7	28	3398.0	6.6	2171.6	1226.4	786.9
55	4.7	27	3278.9	6.5	2092.3	1186.6	790.9
56	4.7	26	3159.1	6.4	2015.4	1143.7	791.5
57	4.7	25	3038.8	6.3	1940.8	1098.0	788.5
58	4.7	24	2918.1	6.2	1868.2	1049.9	782.1
59	4.7	23	2797.2	6.1	1797.5	999.7	772.2
60	4.8	22	2676.1	6.0	1728.4	947.7	758.9
61	4.8	21	2554.9	5.9	1660.6	894.2	742.0
62	4.9	20	2433.5	5.8	1594.1	839.5	721.7
63	4.9	19	2312.0	5.7	1528.3	783.7	697.9
64	5.0	18	2190.3	5.5	1463.2	727.1	670.6
65	5.1	17	2068.3	5.4	1398.3	670.0	639.9

Design Equations (Vector Analysis):
 $a = c_{FS} * L_{CR} * \sin(90 + \phi_{FS}) / \sin(\alpha - \phi_{FS})$
 $b = W - a$
 $P_A = b * \tan(\alpha - \phi_{FS})$
 $EFP = 2 * P_A / H^2$

Maximum Active Pressure Resultant

$$P_{A, \max}$$

791.5 | lbs/lineal foot

Equivalent Fluid Pressure (per lineal foot of shoring)

$$EFP = 2 * P_A / H^2$$

EFP

15.8 pcf

Design Shoring for an Equivalent Fluid Pressure:

28 pcf



Soil Corrosivity Evaluation Report for Grubb Properties

December 7, 2021

**Prepared for:
Gregorio Varela
Geotechnologies, Inc.
439 Western Ave.
Glendale, CA, 91201
gvarela@geoteq.com**

**Project X Job #: S211203F
Client Job or PO #: 22207**



Contents

1	Executive Summary	4
2	Corrosion Control Recommendations.....	5
2.1	Cement	5
2.2	Steel Reinforced Cement/ Cement Mortar Lined & Coated (CML&C)	5
2.3	Stainless Steel Pipe/Conduit/Fittings	6
2.4	Steel Post Tensioning Systems.....	6
2.5	Steel Piles	6
2.5.1	Expected Corrosion Rate of Steel and Zinc in disturbed soil	7
2.5.2	Expected Corrosion Rate of Steel and Zinc in Undisturbed soil	8
2.6	Steel Storage tanks	8
2.7	Steel Pipelines	8
2.8	Steel Fittings.....	10
2.9	Ductile Iron (DI) & Cast Iron Fittings	10
2.10	Ductile Iron & Cast Iron Pipe.....	11
2.11	Copper Materials	13
2.11.1	Copper Pipes	13
2.11.2	Brass Fittings	13
2.11.3	Bare Copper Grounding Wire.....	14
2.12	Aluminum Pipe/Conduit/Fittings	15
2.13	Carbon Fiber or Graphite Materials.....	15
2.14	Plastic and Vitrified Clay Pipe	15
3	CLOSURE	16
4	Soil analysis lab results	17
5	Corrosion Basics	20
5.1	Pourbaix Diagram – In regards to a material’s environment	20
5.2	Galvanic Series – In regards to dissimilar metal connections.....	20
5.3	Corrosion Cell	23
5.4	Design Considerations to Avoid Corrosion	24
5.4.1	Testing Soil Factors (Resistivity, pH, REDOX, SO, CL, NO3, NH3)	24
5.4.2	Proper Drainage	25
5.4.3	Avoiding Crevices	25
5.4.4	Coatings and Cathodic Protection.....	26



5.4.5	Good Electrical Continuity	28
5.4.6	Bad Electrical Continuity.....	29
5.4.7	Corrosion Test Stations.....	29
5.4.8	Excess Flux in Plumbing	30
5.4.9	Landscapers and Irrigation Sprinkler Systems	30
5.4.10	Roof Drainage splash zones.....	30
5.4.11	Stray Current Sources	31



1 Executive Summary

A corrosion evaluation of the soils at Grubb Properties was performed to provide corrosion control recommendations for general construction materials. The site is located at 1200 North Vine St, Los Angeles, CA. Two (2) samples were tested to a depth of 20 ft. Site ground water and topography information was provided by Geotechnologies, Inc.. Groundwater depth was determined to be 20 feet below finished grade.

Every material has its weakness. Aluminum alloys, galvanized/zinc coatings, and copper alloys do not survive well in very alkaline or very acidic pH environments. Copper and brasses do not survive well in high nitrate or ammonia environments. Steels and irons do not survive well in low soil resistivity and high chloride environments. High chloride environments can even overcome and attack steel encased in normally protective concrete. Concrete does not survive well in high sulfate environments. And nothing survives well in high sulfide and low redox potential environments with corrosive bacteria. This is why Project X tests for these 8 factors to determine a soil's corrosivity towards various construction materials. **Depending solely on soil resistivity or Caltrans corrosion guidelines (which concentrate on concrete/steel highways), will over-simplify descriptions as corrosive or non-corrosive. This approach will not detect these other factors attacking other metals because it is possible to have bad levels of corrosive ions and still have greater than 1,100 ohm-cm soil resistivity. We have observed this fact on thousands of soil samples tested in our laboratory.**

It should not be forgotten that import soil should also be tested for all factors to avoid making your site more corrosive than it was to begin with.

The recommendations outlined herein are not a substitute for any design documents previously prepared for the purpose of construction and apply only to the depth of samples collected.

Soil samples were tested for minimum resistivity, pH, chlorides, sulfates, ammonia, nitrates, sulfides and redox.

As-Received soil resistivities ranged between 14,740 ohm-cm and 20,770.0 ohm-cm. This data would be similar to a Wenner 4 pin test in the field and used in the design of a cathodic protection or grounding bed system. This resistivity can change seasonally depending on the weather and moisture in the ground. This reading alone can be misleading because condensation or minor water leaks will occur underground along pipe surfaces creating a saturated soil environment in the trench on infrastructure surfaces. This is why minimum or saturated soil resistivity measurements are more important than as-received resistivities.

Saturated soil resistivities ranged between 2,010 ohm-cm to 2,211 ohm-cm. The worst of these values is considered to be moderately corrosive to general metals.

PH levels ranged between 8.0 to 8.1 pH. PH levels were determined to be at levels not detrimental to copper or aluminum alloys. The pH of these samples can allow corrosion of steel and iron in moist environments.

Chlorides ranged between 6 mg/kg to 17 mg/kg. Chloride levels in these samples are low and may cause insignificant corrosion of metals.

Sulfates ranged between 33 mg/kg to 36 mg/kg. Sulfate levels in these samples are negligible for corrosion of cement. Any type of cement can be used that does not contain encased metal.



Ammonia ranged between 0.6 mg/kg to 1.8 mg/kg. Nitrates ranged between 24.4 mg/kg to 36.8 mg/kg. Concentrations of these elements were not high enough to cause accelerated corrosion of copper and copper alloys such as brass.

Sulfides presence was determined to be negative. REDOX ranged between + 210 mV to + 215 mV. The probability of corrosive bacteria was determined to be low due to the sulfide and positive REDOX levels determined in these samples.

2 Corrosion Control Recommendations

The following recommendations are based upon the results of soil testing.

2.1 Cement

The highest reading for sulfates was 36 mg/kg or 0.0036 percent by weight.

Per ACI 318-14, Table 19.3.1.1, sulfate levels in these samples categorized as S0 and are negligible for corrosion of metals and cement. Per ACI 318-14 Table 19.3.2.1 any type of cement not containing steel or other metal can be used.

2.2 Steel Reinforced Cement/ Cement Mortar Lined & Coated (CML&C)

Chlorides in soil can overcome the corrosion inhibiting property of cement for steel, as it can also break through passivated surfaces of aluminum and stainless steels.^{1,2} The highest concentration of chlorides was 17 mg/kg.

Chloride levels in these samples are not significantly corrosive to metals not in tension. Standard cement cover may be used in these soils.

Though soils at some locations are significantly corrosive to various metals, per ACI 318-14 Chapter 19 Table 19.3.1.1, all slabs on this site exposure categories and class for **Corrosion Protection of Reinforcement (C) would be considered C1** as Concrete exposed to moisture [mud/rain] (slab sides and bottom) but not to an external source of chlorides. Though there are chlorides in the soil, ACI 318's definition of "external source of chlorides" consists of deicing chemicals, salt, brackish water, seawater, or spray from these sources. The chloride levels in seawater are typically over 19,000 mg/L or 19,000 ppm.

When concrete is tested for water-soluble chloride ion content, the tests should be made at an age of 28 to 42 days. The limits in Per ACI 318-14 Table 5.3.2.1 are to be applied to chlorides contributed from the concrete ingredients, not those from the environment surrounding the concrete.³

¹ Design Manual 303: Cement Cylinder Pipe. Ameron. p.65

² Chapter 19, Table 1904.2.2(1), 2012 International Building Code

³ ACI 318-14., BUILDING CODE REQUIREMENTS FOR STRUCTURAL CONCRETE (ACI 318-14) AND COMMENTARY (ACI 318R-14)



2.3 Stainless Steel Pipe/Conduit/Fittings

Stainless steels derive their corrosion resistance from their chromium content and oxide layer which needs oxygen to regenerate if damaged. Thus stainless steel is not good for deep soil applications where oxygen levels are extremely low. Stainless steels should not be installed deeper than a plant root zone. Stainless steels typically have the same nobility as copper on the galvanic series and can be connected to copper. If stainless steel must be used, it must be backfilled with soil having greater than 10,000 ohm-cm resistivity and excellent drainage. 304 Stainless steel will also corrode if in contact with carbon materials such as activated carbon. Stainless steel welds should be pickled.

The soil at this site has low probability for anaerobic corrosive bacteria and low chloride levels. Per Nickel Institute guidelines, 304 or 316 Stainless steels can be used in these soils.

2.4 Steel Post Tensioning Systems

The proper sealing of stressing holes is of utmost importance in PT Systems. Cut off excess strand 1/2" to 3/4" back in the hole. Coat or paint exposed anchorage, grippers, and stub of strands with "Rust-o-leum" or equal. After tendons have been coated, the cement contractor shall dry pack blockouts within ten (10) days. A non-shrink, non-metallic, non-porous moisture-insensitive grout (Master EMACO S 488 or equivalent), or epoxy grout shall be used for this purpose. If an encapsulated post-tension system is used, regular non-shrink grout can be used.

Due to the low chloride concentrations measured on samples obtained from this site, post-tensioned slabs should be protected in accordance with soil considered normal (non-corrosive).^{4,5} Addition of grease caps to the cut strand at live end anchors can deter construction defect accusations but are not needed.

2.5 Steel Piles

Steel piles are most susceptible to corrosion in disturbed soil where oxygen is available. Further, a dissimilar environment corrosion cell would exist between the steel embedded in cement, such as pile caps and the steel in the soil. In the cell, the steel in the soil is the anode (corroding metal), and the steel in cement is the cathode (protected metal). This cell can be minimized by coating the part of the steel piles that will be embedded in cement to prevent contact with cement and reinforcing steel.

Piles driven into soils without disturbing soils will avoid oxygen introduction and low corrosion rates unless there is a probability for corrosive anaerobic bacteria. Galvanized steel's zinc coating can provide significant protection for driven piles. In corrosive soils in which normal zinc coatings are not enough, the life of piles can be extended by increasing zinc coating thickness, using sacrificial metal, or providing a combination of epoxy coatings and cathodic protection. Corrosion has been observed to be extremely localized even at and below underground water tables. Pit depths of this magnitude do not have an appreciable effect on the strength or useful life of piling structures because the reduction in pile cross section is not

⁴ *Standard Requirements for Design and Analysis of Shallow Post-Tensioned Concrete Foundations on Expansive Soils, PTI DC10.5-12, Table 4.1, pg 16*

⁵ *Specification for Unbonded Single Strand Tendons. Post-tensioning Institute (PTI), Phoenix, AZ, 2000.*



significant.⁶ Pitting is of more importance to pipes transporting liquids or gases which should not be leaked into the ground.

The following recommendations are recommended to achieve desired life. We defer to structural engineers to use our estimated corrosion rates and to choose from the corrosion control options listed below.

- 1) Sacrificial metal by use of thicker piles per non-disturbed soil corrosion rates, or
- 2) Galvanized steel piles per non-disturbed soil corrosion rates, or
- 3) Combination of galvanized and sacrificial metal per non-disturbed soil corrosion rates, or
- 4) For no loss of metal, coat entire pile with abrasion resistant epoxy coating such as 3M Scotchkote 323, or PowercreteDD, or equivalent, or
- 5) Use high yield steel which will corrode at the same rate as mild steel but have greater yield strength and thus be able to suffer more material loss than mild steel.

2.5.1 Expected Corrosion Rate of Steel and Zinc in disturbed soil

In general, the corrosion rate of metals in soil depends on the electrical resistivity, the elemental composition, and the oxygen content of the soil. Soils can vary greatly from one acre to the next, especially at earthquake faults. The better a soil is for farming; the easier it will be for corrosion to take place. Expansive soils will also be considered disturbed simply because of their nature from dry to wet seasons.

In Melvin Romanoff's NBS Circular 579, the corrosion rates of carbon steels and various metals was studied over long term periods. Various metals were placed in various soil types to gather corrosion rate data of all metals in all soil types. Samples were collected and material loss measured over the course of 20 years in some sites. The following corrosion rates were estimated by comparing the worst results of soils tested with similar soils in Romanoff's studies and Highway Research Board's publications.⁷ The corrosion rate of zinc in disturbed soils is determined per Romanoff studies and King Nomograph.⁸

Expected Corrosion Rate for Steel = 1.53 mils/year for one sided attack

Expected Corrosion Rate for Zinc = 0.34 mils/year for one sided attack.

Note: 1 mil = 0.001 inch

In undisturbed soils, a corrosion rate of 1 mil/year for steel is expected with little change in the corrosion rate of zinc due to its low nobility in the galvanic series.

Per CTM 643: Years to perforation of corrugated galvanized steel culverts

- 33.9 Years to Perforation for a 18 gage metal culvert
- 44.1 Years to Perforation for a 16 gage metal culvert

⁶ Melvin Romanoff, Corrosion of Steel Pilings in Soils, National Bureau of Standards Monograph 58, pg 20.

⁷ Field test for Estimating Service Life of Corrugated Metal Culverts, J.L. Beaton, Proc. Highway Research Board, Vol 41, P. 255, 1962

⁸ King, R.A. 1977, Corrosion Nomograph, TRRC Supplementary Report, British Corrosion Journal



- 54.3 Years to Perforation for a 14 gage metal culvert
- 74.6 Years to Perforation for a 12 gage metal culvert
- 94.9 Years to Perforation for a 10 gage metal culvert
- 115.3 Years to Perforation for a 8 gage metal culvert

2.5.2 Expected Corrosion Rate of Steel and Zinc in Undisturbed soil

Expected Corrosion Rate for Steel = 1 mils/year for one sided attack

Expected Corrosion Rate for Zinc = 0.34 mils/year for one sided attack.

Note: 1 mil = 0.001 inch

2.6 Steel Storage tanks

Underground fuel tanks must be constructed and protected in accordance with California Underground Storage Tank Regulations, CCR, Title 23, Division 3, Chapter 16. Metals should be protected with cathodic protection or isolated from backfill material with an epoxy coating.

2.7 Steel Pipelines

Though a site may not be corrosive in nature at the time of construction, **installation of corrosion test stations and electrical continuity joint bonding should be performed during construction** so that future corrosion inspections can be performed. If steel pipes with gasket joints or other possibly non-conductive type joints are installed, their joints should be bonded across by welding or pin brazing a #8 AWG copper strand bond cable. Electrical continuity is necessary for corrosion inspections and for cathodic protection.

Corrosion test stations should be installed every 1,000 feet of pipeline.

Test stations shall have two #8 HMWPE copper strand wire test leads welded or pin brazed to the underground pipe, brought up into the test station hand hole and marked CTS. Wires should be brought into test station hand hole at finished grade with 12 inches of wire coiled within test station.

At isolation joints and pipe casings, 4 wire test stations shall be installed using #8 HMWPE copper strand wire test leads. Use different color wires to distinguish which wires are bonded to one side of isolation joint or to casing. Wires should be brought into test station hand hole at finished grade with 12 inches of wire coiled within test station.

Prevent dissimilar metal corrosion cells per NACE SP0286:

- 1) Electrically isolate dissimilar metal connections
- 2) Electrically isolate dissimilar coatings (Epoxy vs CML&C) segments connections
- 3) Electrically isolate river crossing segments
- 4) Electrically isolate freeway crossing segments
- 5) Electrically isolate old existing pipelines from new pipelines



- 6) Electrically isolate aboveground and underground pipe segments with flange isolation joint kits per NACE SP0286 to avoid galvanic corrosion cells. **These are especially important for fire risers.**

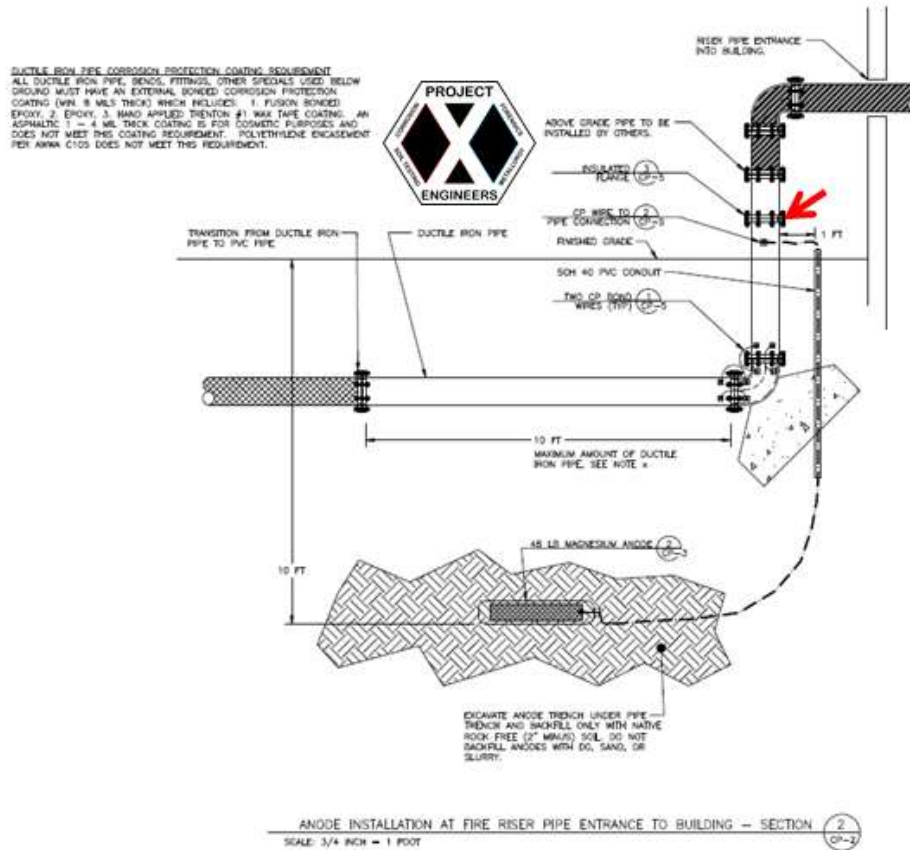

Figure 1- Fire Riser Detail: Install Isolation joint at red arrow

The bare steel surfaces, the corrosivity at this site is mildly corrosive to steel. The corrosion control options for this site are as follows:

- 1) Apply impermeable dielectric coating such as minimum 10 mil thick polyethylene, or
- 2) Tape coating system per AWWA C214, or
- 3) Wax tape per AWWA C217, or
- 4) Coal tar enamel per AWWA C203, or
- 5) Fusion bonded epoxy per AWWA C213, or
- 6) For bare steel surfaces, such as welded pipe joints, apply 3 inch thick field coating of Type II cement or high pH slurry that will maintain pH higher than 12. Cement is both a corrosion inhibitor and a coating for ferrous metals. Cement naturally holds a pH of 12 or higher for many years if not exposed to high levels of carbon dioxide. (For CML&C pipes, CML&C factory applied 3/4 inch thick coating is equivalent and needs no extra thickness added.)

It is critical for the life of the pipe that the protective wrap contains no openings or holes. Prevent damage to the protective sleeve during backfilling of the pipe trench. Penetrations of



any kind within these or other protective materials generally leads to accelerated corrosion failure due to the fact that the corrosion attack is concentrated at the location of these penetrations. Cathodic protection will protect these defects. The better the coating, the less expensive a cathodic protection system will be in anode material and power requirement if needed.

2.8 Steel Fittings

The corrosivity at this site is mildly corrosive to steel. The corrosion control options for this site can be one of the following:

- 1) Apply impermeable dielectric coating such as minimum 10 mil thick polyethylene, or
- 2) Tape coating system per AWWA C214, or
- 3) Wax tape per AWWA C217, or
- 4) Coal tar enamel per AWWA C203, or
- 5) Fusion bonded epoxy per AWWA C213
- 6) Use powder coated steel with minimum 60 micron (2-3 mil) thick coating⁹, or
- 7) Galvanized steel, or
- 8) Apply standard concrete cover of Type II cement or high pH slurry that will maintain pH higher than 12. Cement is both a corrosion inhibitor and a coating for ferrous metals. Cement naturally holds a pH of 12 or higher for many years if not exposed to high levels of carbon dioxide.

It is critical for the life of the metal that the protective wrap contains no openings or holes. Prevent damage to the protective sleeve during backfilling of the pipe trench. Penetrations of any kind within these or other protective materials generally leads to accelerated corrosion failure due to the fact that the corrosion attack is concentrated at the location of these penetrations. Cathodic protection will protect these defects. The better the coating, the less expensive a cathodic protection system will be in anode material and power requirement if needed.

2.9 Ductile Iron (DI) & Cast Iron Fittings

AWWA C105 developed a 10 point system to classify sites as aggressive or non-aggressive to ductile iron materials. The 10-point system does not, and was never intended to, quantify the corrosivity of a soil. It is a tool used to distinguish nonaggressive from aggressive soils relative to iron pipe. Soils <10 points are considered nonaggressive to iron pipe, whereas soils ≥ 10 points are considered aggressive. A 15 and a 20 point soil are both considered aggressive to iron pipe, however, because of the nature of the soil parameters measured, the 20 point soil may not necessarily be more aggressive than the 15 point soil. The criterion is based upon soil resistivities, soil drainage, pH, sulfide presence, and reduction-oxidation (REDOX) potential. The soil samples tested for this site resulted in a score of 1 out of 25.5. A score greater or equal

⁹ Manish Kumar Bhadu, Akshya Kumar Guin, Veena Singh, Shyam K. Choudhary, "Corrosion Study of Powder-Coated Galvanised Steel", International Scholarly Research Notices, vol. 2013, Article ID 464710, 9 pages, 2013



to 10 points classifies soils as aggressive to iron materials. The black coating on iron pipes is purely for aesthetic purposes and should not be relied upon for corrosion protection.¹⁰

The corrosivity at this site is mildly corrosive to iron. The corrosion control options for this site are as follows:

- 1) Apply impermeable dielectric coating such as minimum 10 mil thick polyethylene, or
- 2) Tape coating system per AWWA C214, or
- 3) Wax tape per AWWA C217, or
- 4) Coal tar enamel per AWWA C203, or
- 5) Fusion bonded epoxy per AWWA C213
- 6) Apply standard concrete cover of Type II cement or high pH slurry that will maintain pH higher than 12. Cement is both a corrosion inhibitor and a coating for ferrous metals. Cement naturally holds a pH of 12 or higher for many years if not exposed to high levels of carbon dioxide.

It is critical for the life of the metal that the protective wrap contains no openings or holes. Prevent damage to the protective sleeve during backfilling of the pipe trench. Penetrations of any kind within these or other protective materials generally leads to accelerated corrosion failure due to the fact that the corrosion attack is concentrated at the location of these penetrations. Cathodic protection will protect these defects. The better the coating, the less expensive a cathodic protection system will be in anode material and power requirement if needed.

2.10 Ductile Iron & Cast Iron Pipe

AWWA C105 developed a 10 point system to classify sites as aggressive or non-aggressive to ductile iron materials. The 10-point system does not, and was never intended to, quantify the corrosivity of a soil. It is a tool used to distinguish nonaggressive from aggressive soils relative to iron pipe. Soils <10 points are considered nonaggressive to iron pipe, whereas soils ≥ 10 points are considered aggressive. A 15 and a 20 point soil are both considered aggressive to iron pipe, however, because of the nature of the soil parameters measured, the 20 point soil may not necessarily be more aggressive than the 15 point soil. The criterion is based upon soil resistivities, soil drainage, pH, sulfide presence, and reduction-oxidation (REDOX) potential. The soil samples tested for this site resulted in a score of 1 out of 25.5. A score greater or equal to 10 points classifies soils as aggressive to iron materials. The black coating on iron pipes is purely for aesthetic purposes and should not be relied upon for corrosion protection.¹¹

Though a site may not be corrosive in nature at the time of construction, **installation of corrosion test stations and electrical continuity joint bonding should be performed during construction** so that future corrosion inspections can be performed. If steel pipes with gasket joints or other possibly non-conductive type joints are installed, their joints should be bonded across by welding or pin brazing a #8 AWG copper strand bond cable. Electrical continuity is necessary for corrosion inspections and for cathodic protection. **If using thermite, perform one**

¹⁰ <https://www.dipra.org/ductile-iron-pipe-resources/frequently-asked-questions/corrosion-control>

¹¹ <https://www.dipra.org/ductile-iron-pipe-resources/frequently-asked-questions/corrosion-control>



test bond using a half-charge then pressure test to confirm excess heat and pinholes were not created.

Pea gravel is used by plumbers to lay pipes and establish slopes. If the gravel has more than 200 ppm chlorides or is not tested, a 25 mil plastic should be placed between the gravel and pipe to avoid corrosion.

Corrosion test stations should be installed every 1,000 feet of pipeline.

Test stations shall have two #8 HMWPE copper strand wire test leads welded or pin brazed to the underground pipe, brought up into the test station hand hole and marked CTS. Wires should be brought into test station hand hole at finished grade with 12 inches of wire coiled within test station.

At isolation joints and pipe casings, 4 wire test stations shall be installed using #8 HMWPE copper strand wire test leads. Use different color wires to distinguish which wires are bonded to one side of isolation joint or to casing. Wires should be brought into test station hand hole at finished grade with 12 inches of wire coiled within test station.

Prevent dissimilar metal corrosion cells per NACE SP0286:

- 1) Electrically isolate dissimilar metal connections
- 2) Electrically isolate dissimilar coatings (Epoxy vs CML&C) segments connections
- 3) Electrically isolate river crossing segments
- 4) Electrically isolate freeway crossing segments
- 5) Electrically isolate old existing pipelines from new pipelines
- 6) Electrically isolate aboveground and underground pipe segments with flange isolation joint kits per NACE SP0286. **These are especially important for fire risers.**

The corrosivity at this site is mildly corrosive to iron. The corrosion control options for this site are as follows:

- 1) Apply impermeable dielectric coating such as minimum 10 mil thick polyethylene, or
- 2) Tape coating system per AWWA C214, or
- 3) Wax tape per AWWA C217, or
- 4) Coal tar enamel per AWWA C203, or
- 5) Fusion bonded epoxy per AWWA C213
- 6) Apply standard concrete cover of Type II cement or high pH slurry that will maintain pH higher than 12. Cement is both a corrosion inhibitor and a coating for ferrous metals. Cement naturally holds a pH of 12 or higher for many years if not exposed to high levels of carbon dioxide.

It is critical for the life of the metal that the protective wrap contains no openings or holes. Prevent damage to the protective sleeve during backfilling of the pipe trench. Penetrations of any kind within these or other protective materials generally leads to accelerated corrosion failure due to the fact that the corrosion attack is concentrated at the location of these penetrations. Cathodic protection will protect these defects. The better the coating, the less



expensive a cathodic protection system will be in anode material and power requirement if needed.

2.11 Copper Materials

Copper is an amphoteric material which is susceptible to corrosion at very high and very low pH. It is one of the most noble metals used in construction thus typically making it a cathode when connected to dissimilar metals. Copper's nobility can change with temperature, similar to the phenomenon in zinc. When zinc is at room temperature, it is less noble than steel and can provide cathodic protection to steel. But when zinc is at a temperature above 140F such as in a water heater, it becomes more noble than the steel and the steel becomes the sacrificial anode. This is why zinc is not used in steel water heaters or boilers. Cold copper has one native potential, but when heated it develops a more electronegative electro-potential aka open circuit potential. Thus hot and cold copper pipes should be electrically isolated from each other to avoid creation of a thermo-galvanic corrosion cell.

2.11.1 Copper Pipes

The lowest pH for this area was measured to be 8.0. Copper is greatly affected by pH, ammonia and nitrate concentrations¹². The highest nitrate concentration was 36.8 mg/kg and the highest ammonia concentration was 1.8 mg/kg at this site.

These soils were determined mildly corrosive to copper and copper alloys such as brass.

Underground, aboveground, cold water, and hot water pipes should be electrically isolated from each other by use of dielectric unions and plastic in-wall pipe supports per NACE SP0286. The following are corrosion control options for underground copper water pipes.

- 1) Cover cold copper piping with minimum 8 mil polyethylene and backfill with clean sand with 2 inch minimum cover above and below tubing. Backfill should have a pH between 6 and 8 with electrical resistivity greater than 2,000 ohm-cm
- 2) Heat increases corrosion rates. Hot water pipes should be installed within PVC piping to prevent soil contact, or
- 3) Cover hot water pipes with minimum 8 mil polyethylene sleeve or incase in double 4-mil thick polyethylene sleeves over a suitable primer

It is critical for the life of the metal that the protective wrap contains no openings or holes. Prevent damage to the protective sleeve during backfilling of the pipe trench. Penetrations of any kind within these or other protective materials generally leads to accelerated corrosion failure due to the fact that the corrosion attack is concentrated at the location of these penetrations. Cathodic protection will protect these defects. The better the coating, the less expensive a cathodic protection system will be in anode material and power requirement if needed.

2.11.2 Brass Fittings

Brass fittings should be electrically isolated from dissimilar metals by use of dielectric unions or isolation joint kits per NACE SP0286.

¹² Corrosion Data Handbook, Table 6, Corrosion Resistance of copper alloys to various environments, 1995



These soils were determined to be mildly corrosive to copper and copper alloys such as brass.

The following are corrosion control options for underground brass.

- 1) Cover with minimum 10 mil polyethylene or other impermeable coating and backfill with clean sand with 4 inch minimum cover above and below brass. Backfill should have a pH between 6 and 8 with electrical resistivity greater than 2,000 ohm-cm, or
- 2) Wrap fitting or valves in wax tape

It is critical for the life of the metal that the protective wrap contains no openings or holes. Prevent damage to the protective sleeve during backfilling of the pipe trench. Penetrations of any kind within these or other protective materials generally leads to accelerated corrosion failure due to the fact that the corrosion attack is concentrated at the location of these penetrations. Cathodic protection will protect these defects. The better the coating, the less expensive a cathodic protection system will be in anode material and power requirement if needed.

2.11.3 Bare Copper Grounding Wire

It is assumed that corrosion will occur at all sides of the bare wire, thus the corrosion rate is calculated as a two sided attack determining the time it takes for the corrosion from two sides to meet at the center of the wire. The estimated life of bare copper wire for this site is the following:¹³

Size (AWG)	Diameter (mils)	Est. Time to penetration (Yrs)
14	64.1	1068.3
13	72	1200.0
12	80.8	1346.7
11	90.7	1511.7
10	101.9	1698.3
9	114.4	1906.7
8	128.5	2141.7
7	144.3	2405.0
6	162	2700.0
5	181.9	3031.7
4	204.3	3405.0
3	229.4	3823.3
2	257.6	4293.3
1	289.3	4821.7

If the bare copper wire is being used as a grounding wire connected to less noble metals such as galvanized steel or carbon steel, the less noble metals will provide additional cathodic protection to the copper reducing the corrosion rate of the copper.

¹³ Soil-Corrosion studies 1946 and 1948: Copper Alloys, Lead, and Zinc, Melvin Romanoff, National Bureau of Standards, Research Paper RP2077, 1950



It is recommended that a corrosion inhibiting and water-repelling coating be applied to aboveground and belowground copper-to-dissimilar metal connections to reduce risk of dissimilar corrosion. This can be wax tape, or other epoxy coating.

Tinned copper wiring or laying copper wire in conductive concrete can protect against chemical attack in soils with high nitrates, ammonia, sulfide and severely low soil electrical resistivity.

2.12 Aluminum Pipe/Conduit/Fittings

Aluminum is an amphoteric material prone to pitting corrosion in environments that are very acidic or very alkaline or high in chlorides.

Conditions at this site are safe for aluminum.

Aluminum derives its corrosion resistance from its oxide layer which needs oxygen to regenerate if damaged, similar to stainless steels. Thus aluminum is not good for deep soil applications. Since aluminum corrodes at very alkaline environments, it cannot be encased or placed against cement or mortar such as brick wall mortar up against an aluminum window frame.

Aluminum is also very low on the galvanic series scale making it most likely to become a sacrificial anode when in contact with dissimilar metals in moist environments. Avoid electrical continuity with dissimilar metals by use of insulators, dielectric unions, or isolation joints per NACE SP0286. Pooling of water at post bottoms or surfaces should be avoided by integrating good drainage.

2.13 Carbon Fiber or Graphite Materials

Carbon fiber or other graphite materials are extremely noble on the galvanic series and should always be electrically isolated from dissimilar metals. They can conduct electricity and will create corrosion cells if placed in contact within a moist environment with any metal.

2.14 Plastic and Vitrified Clay Pipe

No special precautions are required for plastic and vitrified clay piping from a corrosion viewpoint.

Protect all metallic fittings and pipe restraining joints with wax tape per AWWA C217, cement if previously recommended, or epoxy.



3 CLOSURE

In addition to soils chemistry and resistivity, another contributing influence to the corrosion of buried metallic structures is stray electrical currents. These electrical currents flowing through the earth originate from buried electrical systems, grounding of electrical systems in residences, commercial buildings, and from high voltage overhead power grids. Therefore, it is imperative that the application of protective wraps and/or coatings and electrical isolation joints be properly applied and inspected.

It is the responsibility of the builder and/or contractor to closely monitor the installation of such materials requiring protection in order to assure that the protective wraps or coatings are not damaged.

The recommendations outlined herein are in conformance with current accepted standards of practice that meet or exceed the provisions of the Uniform Building Code (UBC), the International Building Code (IBC), California Building Code (CBC), the American Cement Institute (ACI), Nickel Institute, National Association of Corrosion Engineers (NACE International), Post-Tensioning Institute Guide Specifications and State of California Department of Transportation, Standard Specifications, American Water Works Association (AWWA) and the Ductile Iron Pipe Research Association (DIPRA).

Our services have been performed with the usual thoroughness and competence of the engineering profession. No other warranty or representation, either expressed or implied, is included or intended.

Please call if you have any questions.

Respectfully Submitted,

Ed Hernandez, M.Sc., P.E.
Sr. Corrosion Consultant
NACE Corrosion Technologist #16592
Professional Engineer
California No. M37102
ehernandez@projectxcorrosion.com





4 SOIL ANALYSIS LAB RESULTS

Client: Geotechnologies, Inc.
 Job Name: Grubb Properties
 Client Job Number: 22207
 Project X Job Number: S211203F
 December 7, 2021

Bore# / Description	Method Depth	ASTM D4327 Sulfates		ASTM D4327 Chlorides		ASTM G187 Resistivity		ASTM D4972 pH	ASTM G200 Redox	ASTM D4658 Sulfide	ASTM D4327 Nitrate	ASTM D6919 Ammonium	ASTM D6919 Lithium	ASTM D6919 Sodium	ASTM D6919 Potassium	ASTM D6919 Magnesium	ASTM D6919 Calcium	ASTM D4327 Fluoride	ASTM D4327 Phosphate
		SO ₄ ²⁻ (mg/kg)	(wt%)	Cl ⁻ (mg/kg)	(wt%)	As Rec'd (Ohm-cm)	Minimum (Ohm-cm)												
B1 ML/CL	1-5	33.0	0.0033	6.3	0.0006	20,770	2,211	8.1	215	0.16	24.4	1.8	0.02	19.1	2.3	14.8	54.5	0.8	1.4
B2 ML/CL	1-5	35.7	0.0036	16.6	0.0017	14,740	2,010	8.0	210	0.15	36.8	0.6	0.02	88.4	5.6	19.3	20.4	4.1	2.2

Unk = Unknown

NT = Not Tested

ND = 0 = Not Detected

mg/kg = milligrams per kilogram (parts per million) of dry soil weight

Chemical Analysis performed on 1:3 Soil-To-Water extract

Anions and Cations tested via Ion Chromatograph except Sulfide.

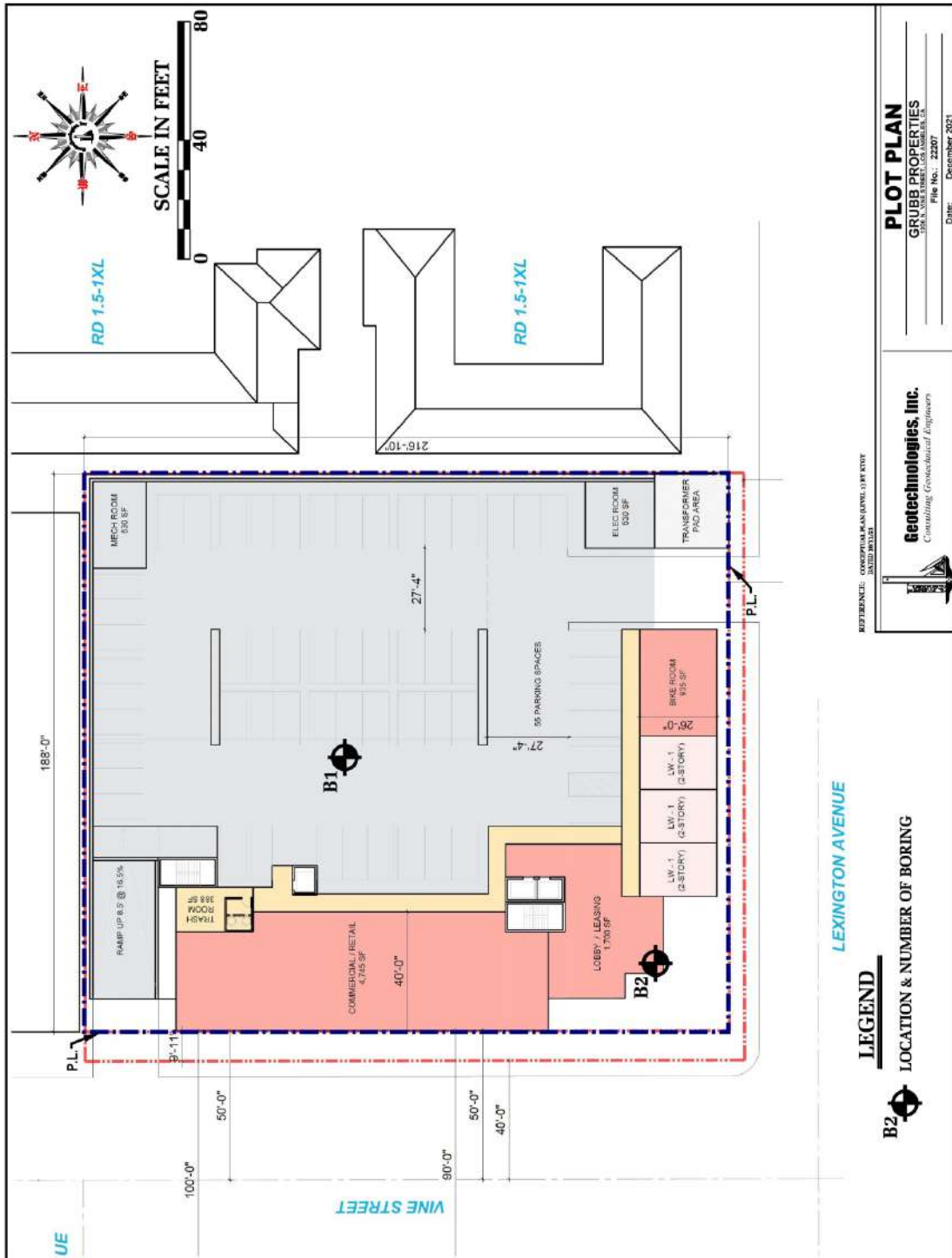



Figure 2- Soil Sample Locations, 1200 North Vine St, Los Angeles, CA

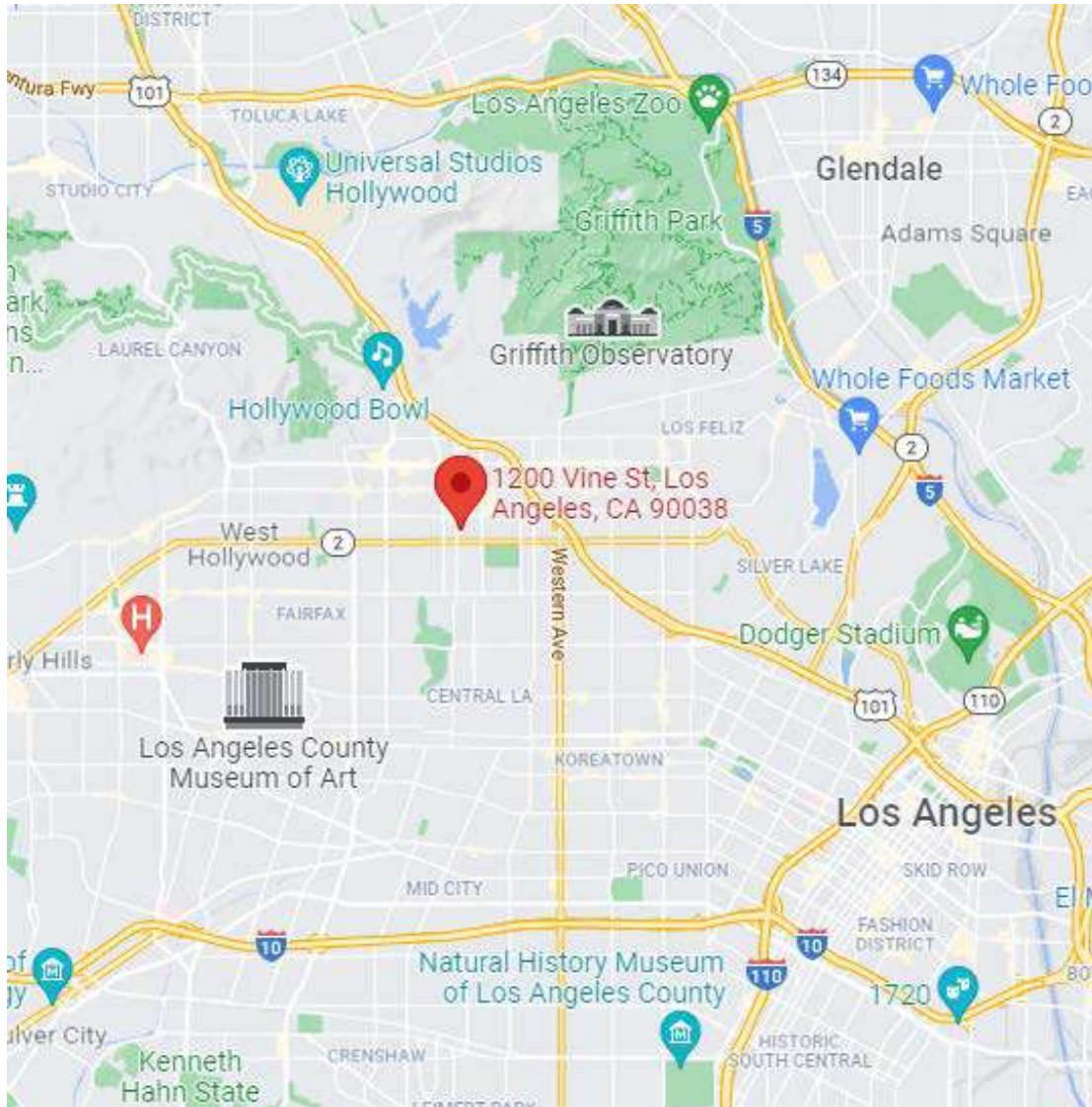

Figure 3- Vicinity Map, 1200 North Vine St, Los Angeles, CA



5 Corrosion Basics

In general, the corrosion rate of metals in soil depends on the electrical resistivity, the elemental composition, and the oxygen content of the soil. Soils can vary greatly from one acre to the next, especially at earthquake faults. The better a soil is for farming; the easier it will be for corrosion to take place. Expansive soils should be considered disturbed simply because of their nature from dry to wet seasons.

5.1 Pourbaix Diagram – In regards to a material's environment

All metals are unique and have a weakness. Some metals do not like acidic (low pH) environments. Some metals do not like alkaline (high pH) environments. Some metals don't like either high or low pH environments such as aluminum. These are called amphoteric materials. Some metals become passivated and do not corrode at high pH environments such as steel. These characteristics are documented in Marcel Pourbaix's book "Atlas of electrochemical equilibria in aqueous solutions"

In the mid 1900's, Marcel Pourbaix developed the Pourbaix diagram which describes a metal's reaction to an environment dependent on pH and voltage conditions. It describes when a metal remains passive (non-corroding) and in which conditions metals become soluble (corrode). Steels are passive in pH over 12 such as the condition when it is encased in cement. If the cement were to carbonate and its pH reduce to below 12, the cement would no longer be able to act as a corrosion inhibitor and the steel will begin to corrode when moist.

Some metals such as aluminum are amphoteric, meaning that they react with acids and bases. They can corrode in low pH and in high pH conditions. Aluminum alloys are generally passive within a pH of 4 and 8.5 but will corrode outside of those ranges. This is why aluminum cannot be embedded in cement and why brick mortar should not be laid against an aluminum window frame without a protective barrier between them.

5.2 Galvanic Series – In regards to dissimilar metal connections

All metals have a natural electrical potential. This electrical potential is measured using a high impedance voltmeter connected to the metal being tested and with the common lead connected to a copper copper-sulfate reference electrode (CSE) in water or soil. There are many types of reference electrodes. In laboratory measurements, a Standard Hydrogen Electrode (SHE) is commonly used. When different metal alloys are tested they can be ranked into an order from most noble (less corrosion), to least noble (more active corrosion). When a more noble metal is connected to a less noble metal, the less noble metal will become an anode and sacrifice itself through corrosion providing corrosion protection to the more noble metal. This hierarchy is known as the galvanic series named after Luigi Galvani whose experiments with electricity and muscles led Alessandro Volta to discover the reactions between dissimilar metals leading to the early battery. The greater the voltage difference between two metals, the faster the corrosion rate will be.



Table 1- Dissimilar Metal Corrosion Risk

	Zinc	Galvanized Steel	Aluminum	Cast Iron	Lead	Mild Steel	Tin	Copper	Stainless Steel
Zinc	None	Low	Medium	High	High	High	High	High	High
Galvanized Steel	Low	None	Medium	Medium	Medium	High	High	High	High
Aluminum	Medium	Medium	None	Medium	Medium	Medium	Medium	High	High
Cast Iron	High	Medium	Medium	None	Low	Low	Low	Medium	Medium
Lead	High	Medium	Medium	Low	None	Low	Low	Medium	Medium
Mild Steel	High	High	Medium	Low	Low	None	Low	Medium	Medium
Tin	High	High	Medium	Low	Low	Low	None	Medium	Medium
Copper	High	High	High	Medium	Medium	Medium	Medium	None	Low
Stainless Steel	High	High	High	Medium	Medium	Medium	Medium	Low	None

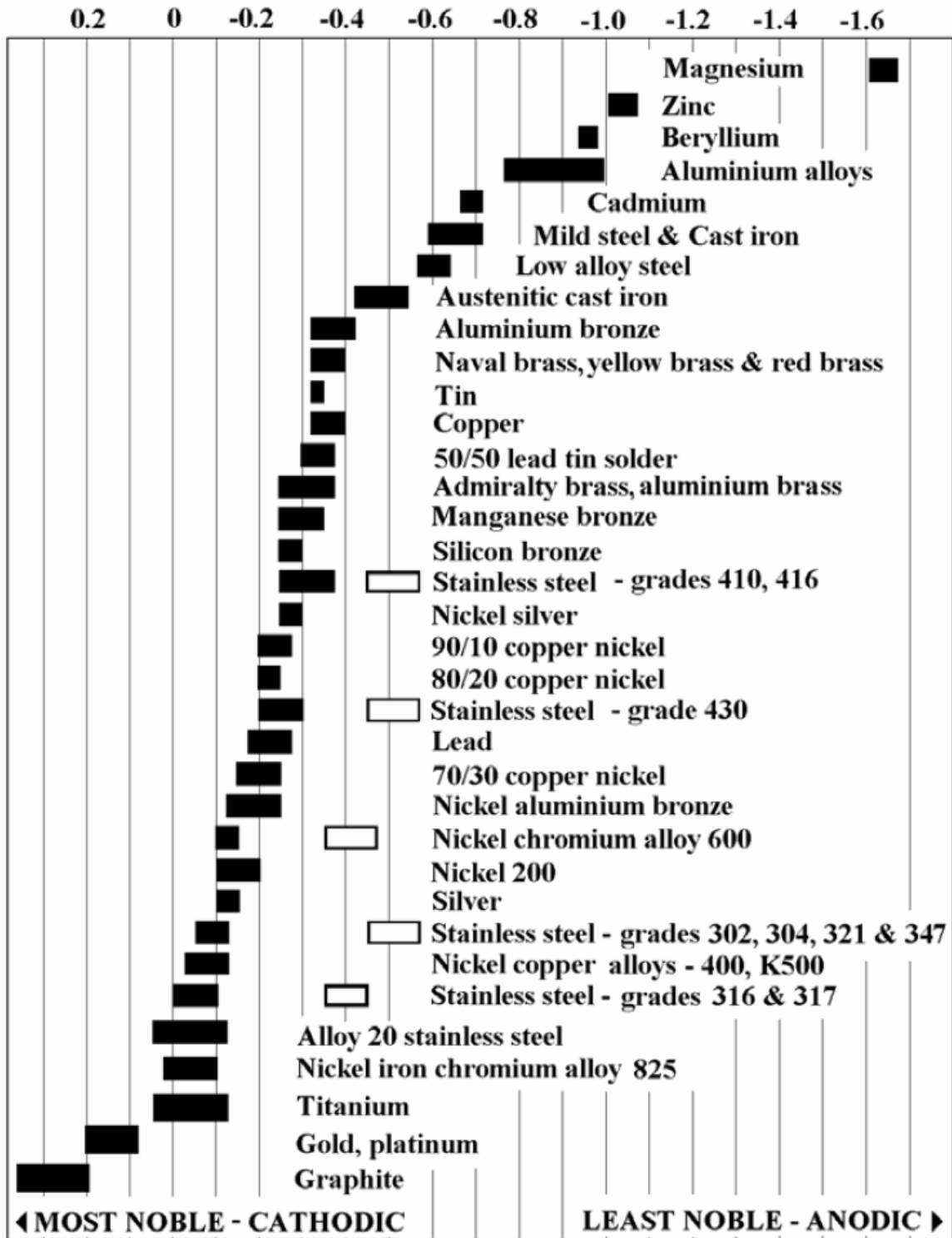

Figure 4 - Galvanic series of metals relative to CSE half cell.



5.3 Corrosion Cell

In order for corrosion to occur, four factors must be present. (1) The anode (2) the cathode (3) the electrolyte and (4) the metallic or conductive path joining the anode and the cathode. If any one of these is removed, corrosion activity will stop. This is how a simple battery produces electricity. An example of a non-metallic yet conductive material is graphite. Graphite is similar in nobility to gold. Do not connect graphite to anything in moist environments.

The anode is where the corrosion occurs, and the cathode is the corrosion free material. Sometimes the anode and cathode are different materials connected by a wire or union. Sometimes the anode and cathode are on the same pipe with one area of the pipe in a low oxygen zone while the other part of the pipe is in a high oxygen zone. A good example of this is a post in the ocean that is repeatedly splashed. Deep underwater, corrosion is minimal, but at the splash zone, the corrosion rate is greatest.

Low oxygen zones and crevices can also harbor corrosive bacteria which in moist environments will lead to corrosion. This is why pipes are laid on backfill instead of directly on native cut soil in a trench. Filling a trench slightly with backfill before installing pipe then finishing the backfill creates a uniform environment around the entire surface of the pipe.

The electrolyte is generally water, seawater, or moist soil which allows for the transfer of ions and electrical current. Pure water itself is not very conductive. It is when salts and minerals dissolve into pure water that it becomes a good conductor of electricity and chemical reactions. Metal ores are turned into metal alloys which we use in construction. They naturally want to return to their natural metal ore state but it requires energy to return to it. The corrosion cell, creates the energy needed to return a metal to its natural ore state.

The metallic or conductive path can be a wire or coupling. Examples are steel threaded into a copper joint, or an electrician grounding equipment to steel pipes inadvertently connecting electrical grid copper grounding systems to steel or iron underground pipes.

The ratio of surface area between the anode and the cathode is very important. If the anode is very large, and the cathode is very small, then the corrosion rate will be very small and the anode may live a long life. An example of this is when short copper laterals were connected to a large and long steel pipeline. The steel had plenty of surface area to spread the copper's attack, thus corrosion was not

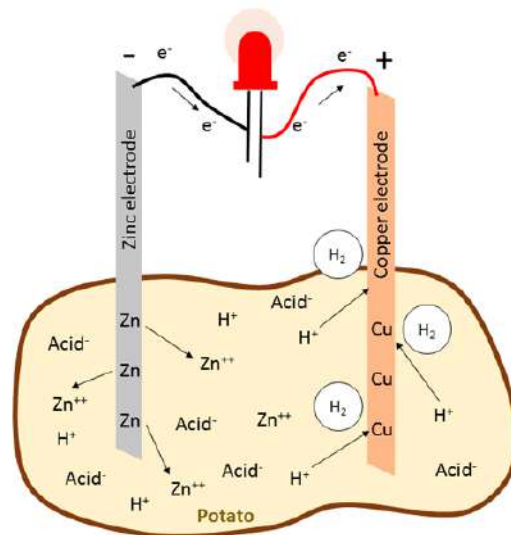
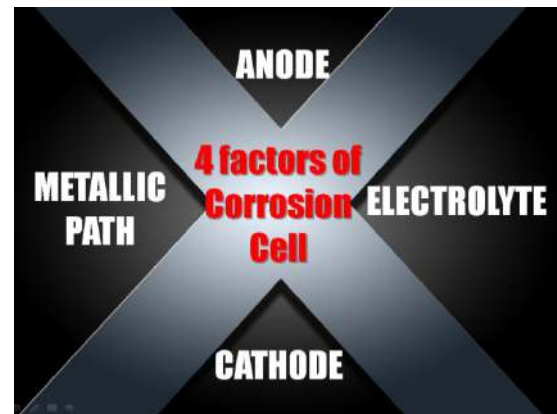



noticeable. But if the copper was the large pipe and the steel the short laterals, the steel would corrode at an amazing rate.

5.4 Design Considerations to Avoid Corrosion

The following recommendations are based upon typical observations and conclusions made by forensic engineers in construction defect lawsuits and NACE International (Corrosion Society) recommendations.

5.4.1 Testing Soil Factors (Resistivity, pH, REDOX, SO, CL, NO3, NH3)

As previously mentioned, different factors can cause corrosion. The most useful and common test for categorizing a soil's corrosivity has been the measure of soil resistivity which is typically measured in units of (ohm-cm) by corrosion engineers and geologists. Soil resistivity is the ability of soil to conduct or resist electrical currents and ion transfer. The lower the soil resistivity, the more conductive and corrosive it is. The following are "generally" accepted categories but keep in mind, the question is not "Is my soil corrosive?", the question should be, "What is my soil corrosive to?" and to answer that question, soil resistivity and chemistry must be tested. Though **soil resistivity is a good corrosivity indicator for steel materials, high chlorides or other corrosive elements do not always lower soil resistivity, thus if you don't test for chlorides and other water soluble salts, you can get an unpleasant surprise.** The largest contributing factor to a soil's electrical resistivity is its clay, mineral, metal, or sand make-up.

Table 2 - Corrosion Basics- An Introduction, NACE, 1984, pg 191

(Ohm-cm)	Corrosivity Description
0-500	Very Corrosive
500-1,000	Corrosive
1,000-2,000	Moderately Corrosive
2,000-10,000	Mildly Corrosive
Above 10,000	Progressively less corrosive

Testing a soil's pH provides information to reference the Pourbaix diagram of specific metals. Some elements such as ammonia and nitrates can create localized alkaline conditions which will greatly affect amphoteric materials such as aluminum and copper alloys.

Excess sulfates can break-down the structural integrity of cement and high concentrations of chlorides can overcome cement's corrosion inhibiting effect on encased ferrous metals and break down protective passivated surface layers on stainless steels and aluminum.

Corrosive bacteria are everywhere but can multiply significantly in anaerobic conditions with plentiful sulfates. The bacteria themselves do not eat the metal but their by-products can form corrosive sulfuric acids. The probability of corrosive bacteria is tested by measuring a soil's oxidation-reduction (REDOX) electro-potential and by testing for the presence of sulfides.

Only by testing a soil's chemistry for minimum resistivity, pH, chlorides, sulfates, sulfides, ammonia, nitrate, and redox potential can one have the information to evaluate the corrosion risk to construction materials such as steel, stainless steel, galvanized steel, iron, copper, brass, aluminum, and concrete.



5.4.2 Proper Drainage

It cannot be emphasized enough that pooled stagnant water on metals will eventually lead to corrosion. This stands for internal corrosion and external corrosion situations. In soils, providing good drainage will lower soil moisture content reducing corrosion rates. Attention to properly sealing polyethylene wraps around valves and piping will avoid water intrusion which would allow water to pool against metals. Above ground structures should not have cupped or flat surfaces that will pond water after rain or irrigation events.

Buildings typically are built on pads and have swales when constructed to drain water away from buildings directing it towards an acceptable exit point such as a driveway where it continues draining to a local storm drain. Many homeowners, landscapers and flatwork contractors appear to not be aware of this and destroy swales during remodeling. The majority of garage floor and finished grade elevations are governed by drainage during design.^{14,15}

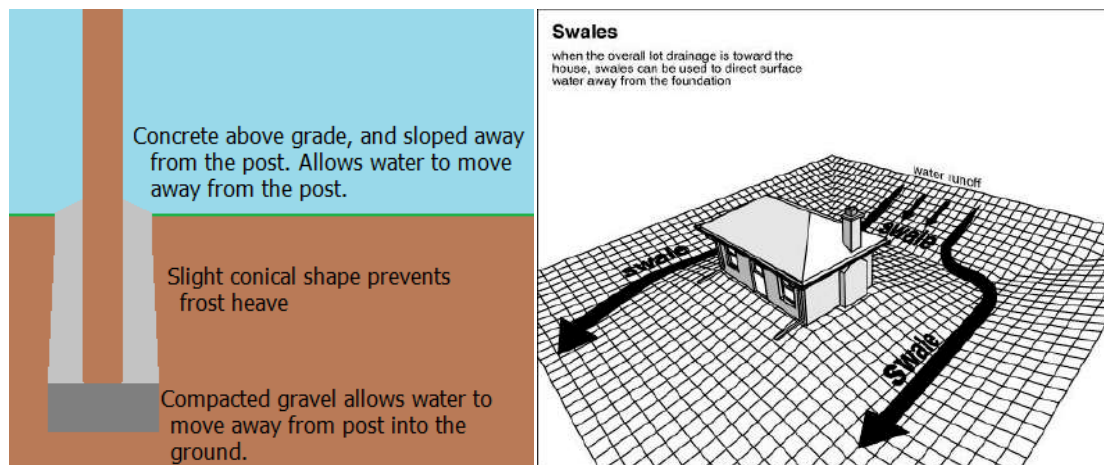

5.4.3 Avoiding Crevices

Crevices are excellent locations for oxygen differential induced corrosion cells to begin. Crevices can also harbor corrosive bacteria even in the most chemically treated waters. Crevices will also gather salts. If water's total alkalinity is low, its ability to maintain a stable pH can also become more difficult within a crevice allowing the pH to drop to acidic levels continuing a pitting process. Welds in extremely corrosive environments should be complete and well filleted without sharp edges to avoid crevices. Sharp edges should be avoided to allow uniform coating of protective epoxy. Detection of crevices in welds should be treated immediately. If pressures and loads are low, sanding and rewelding or epoxy patching can be suitable repairs. Damaged coatings can usually be repaired with Direct to Metal paints. **Scratches and crevice corrosion are like infections, they should not be left to fester or the infection will spread making things worse.**

¹⁴ <https://www.fencedaddy.com/blogs/tips-and-tricks/132606467-how-to-repair-a-broken-fence-post>

¹⁵ <http://southdownstudio.co.uk/problme-drainage-maison.html>

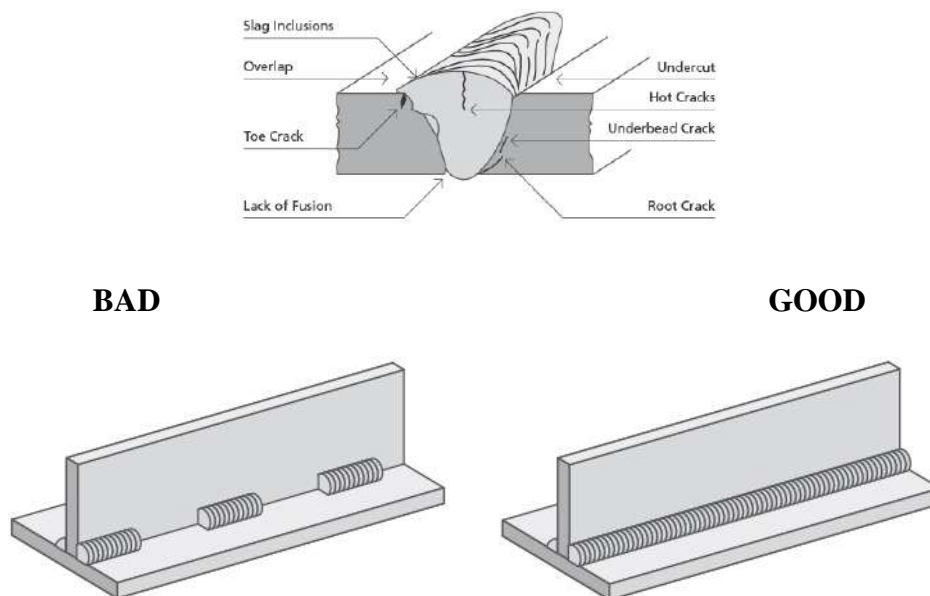

Figure 5 Defects which form weld crevices¹⁶

5.4.4 Coatings and Cathodic Protection

When faced with a corrosive environment, the best defense against corrosion is removing the electrolyte from the corrosion cell by applying coatings to separate the metal from the soil. During construction and installation, there is always some scratch or damage made to a coating. NACE training recommends that coatings be used as a first line of defense and that sacrificial or impressed current cathodic protection is used as a 2nd line of defense to protect the scratched areas. Use of a good coating dramatically reduces the amount of anodes a CP system would need. If CP is not installed as a 2nd line of defense in an extremely corrosive environment, the small scratched zones will suffer accelerated corrosion. CP details such as anode installation instructions must be designed by corrosion engineers or vessel manufacturers on a per project basis because it depends on electrolyte resistivity, surface area of infrastructure to be protected, and system geometry.

There are two types of cathodic protection systems, a Galvanic Anode Cathodic Protection (GACP) system and an Impressed Current Cathodic Protection (ICCP) system. A Galvanic Anode Cathodic Protection (GACP) system is simpler to install and maintain than an Impressed Current Cathodic Protection (ICCP) system. To protect the metals, they must all be electrically continuous to each other. In a GACP system, sacrificial zinc or magnesium anodes are then buried at locations per the CP design and connected by wire to a structure at various points in system. At the connection points, a wire connecting to the structure and the wire from the anode are joined in a Cathodic Protection Test Station hand hole which looks similar in size and shape to an irrigation valve pull box. By coating the underground structures, one can reduce the number of anodes needed to provide cathodic protection by 80% in many instances.

An ICCP system requires a power source, a rectifier, significantly more trenching, and more expensive type anodes. These systems are typically specified when bare metal is requiring protection

¹⁶ <http://www.daroproducts.co.uk/makes-good-weld/>



in severely corrosive environments in which galvanic anodes do not provide enough power to polarize infrastructure to -850 mV structure-to-soil potential or be able to create a 100 mV potential shift as required by NACE SP169 to control corrosion. In severely corrosive environments, a GACP system simply may not last a required lifetime due to the high rate of consumption of the sacrificial anodes. ICCP system rectifiers must be inspected and adjusted quarterly or at a minimum bi-annually per NACE recommendations. Different anode installations may be possible but for large sites, anodes are placed evenly throughout the site and all anode wires must be trenched to the rectifier. For a large site, it may be beneficial to use two or more rectifiers to reduce wire lengths or trenching.

To simplify, a GACP system can be installed and practically forgotten with minor trenching because the anodes can be installed very close to the structures. An ICCP system must be inspected annually and anode wires run back to the rectifier which itself connects to the pile system. If any type of trenching or development is expected to occur at the site during the life of the site, it is a good idea to inspect the anode connections once a year to make sure wires are not cut and that the infrastructure is still being provided adequate protection. A common situation that occurs with ICCP systems is that a contractor accidentally cuts the wires during construction then reconnects them incorrectly, turning the once cathode, into a sacrificing anode.

Design of a cathodic protection system protecting against soil side corrosion requires that Wenner Four Pin ground resistance measurements per ASTM G57 be performed by corrosion engineers at various locations of the site to determine the best depths and locations for anode installations. Ideally, a sample pile is installed and experiments determining current requirement are conducted. Using this data, the decision is made whether a GACP system is feasible or if an ICCP must be used.

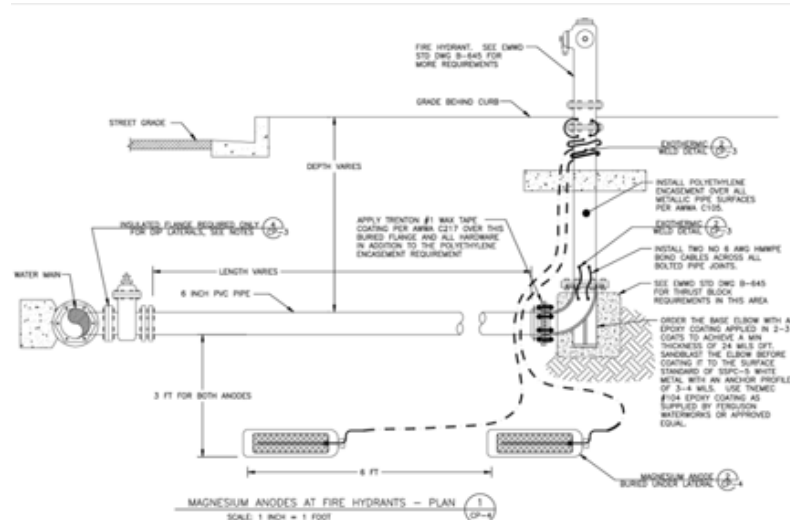

Figure 6 Sample anode design for fire hydrant underground piping

Vessels such as water tanks will have protective interior coatings and anodes to protect the interior surfaces. Anodes can also be buried on site and connected to system metal supports to protect the metal in contact with soil. A good example of a vessel cathodic protection system exists in all home water heaters which contain sacrificial aluminum or magnesium anodes. In environments that exceed 140F, zinc anodes cannot be used with carbon steel because they become the aggressor (Cathodic) to



the steel instead of sacrificial (anodic). Anodes in vessels containing extremely brackish water with chloride levels over 2,000 ppm should inspect or change out their anodes every 6 months.

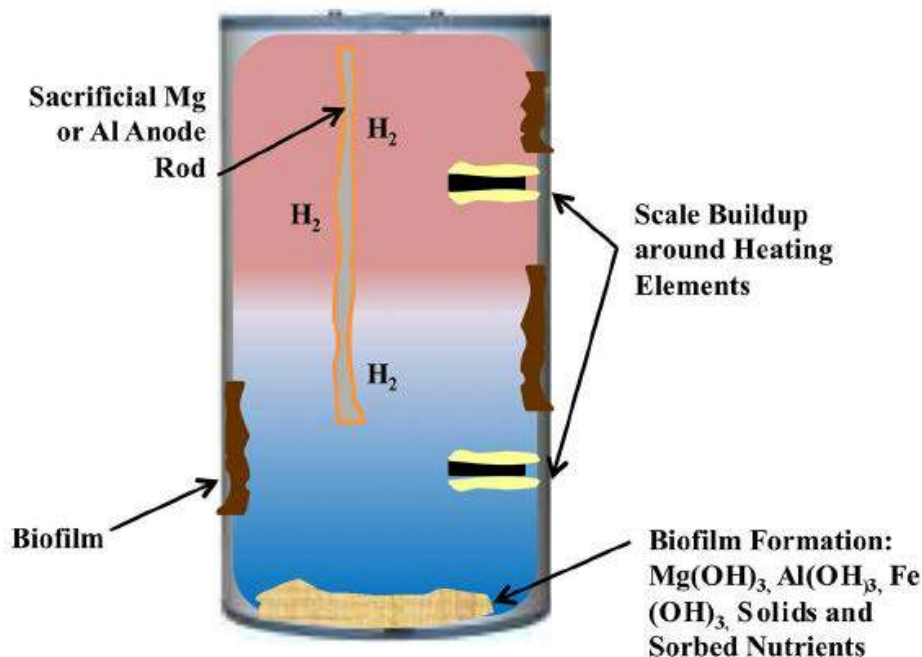

Figure 7 Cross section of boiler with anode

Cathodic protection can only protect a few diameters within a pipeline thus it is not recommended for small diameter pipelines and tubing internal corrosion protection. Anodes are like a lamp shining light in a room. They can only protect along their line of sight.

5.4.5 Good Electrical Continuity

In order for cathodic protection to protect a long pipeline or system of pipes from external soil side corrosion, they must all be electrically continuous to each other so that the electric current from the anode can travel along the pipes, then return through the earth to the anode. Electrical continuity is achieved by welding or pin brazing #8 AWG copper strand bond cable to the end of pipe sticks which have rubber gaskets at bell and spigots. If steel pipes are joined by full weld, bonding wires are not needed.

Electrical continuity between dissimilar metals is not desirable. Isolation joints or di-electric unions should be installed between dissimilar metals, such as steel pipes connecting to a brass valve per NACE SP0286. Bonding wires should then be welded onto the steel pipes by-passing the brass valve so that the cathodic protection system's current can continue to travel along the steel piping but isolate the brass valve from the steel pipeline. Another option would be to provide a separate cathodic protection system for steel pipes on both sides of the brass valve.

Typically, water heater inlets and outlets, gas meters and water meters have dielectric unions installed in them to separate utility property from homeowner property. This also protects them in the case that a home owner somehow electrically connects water pipes or gas pipes to a neighborhood electrical grounding system which can potentially have less noble steel in soil now connected to much



more noble copper in soil which will then create a corrosion cell. This is exactly how a lemon powered clock works when a galvanized zinc nail and a steel nail are inserted into a lemon then connected to a clock. The clock is powered by the corrosion cell created.

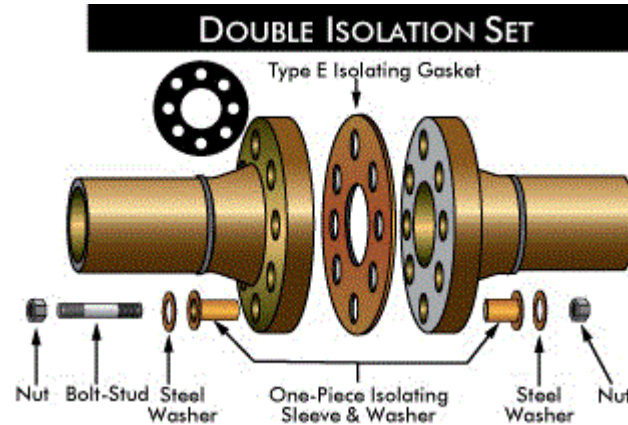

5.4.6 Bad Electrical Continuity

Bad electrical continuity is when two different materials or systems are made electrically continuous (aka shorted) when they were not designed to be electrically continuous. Examples of this would be when gas lines are shorted to water lines or to electrical grounding beds. Very often, fire risers are shorted to electrical grounding systems, and water pipes at business parks. Since fire risers usually have a very short ductile iron pipe in the ground which connects to PVC pipe systems, they tend to experience leaks after 7 to 10 years of being attacked by underground copper systems.

It is absolutely imperative that any copper water piping or other metal conduits penetrating cement slab or footings, not come in contact with the reinforcing steel or post-tensioning tendons to avoid creation of galvanic corrosion cells.

5.4.7 Corrosion Test Stations

Corrosion test stations should be installed every 1,000 feet along pipelines in order to measure corrosion activity in the future. For a simple pipeline, two #8 AWG copper strand bond cable welded or pin brazed onto the pipeline are run up to finished grade and left in a hand hole. Corrosion test stations are used to measure pipe-to-soil electro potential relative to a copper-copper-sulfate reference electrode to determine if the pipe is experiencing significant corrosion activity. By measuring test stations along a pipeline, hot spots can be determined, if any. The wires also allow for electrical continuity testing, condition assessment, and a multitude of other types of tests.

At isolation joints and pipe casings, two wires should be welded to either side of the isolation joint for a total of 4 wires to be brought up to the hand hole. This allows for future tests of the isolation joint, casing separation confirmation, and pipe-to-soil potential readings during corrosion surveys.

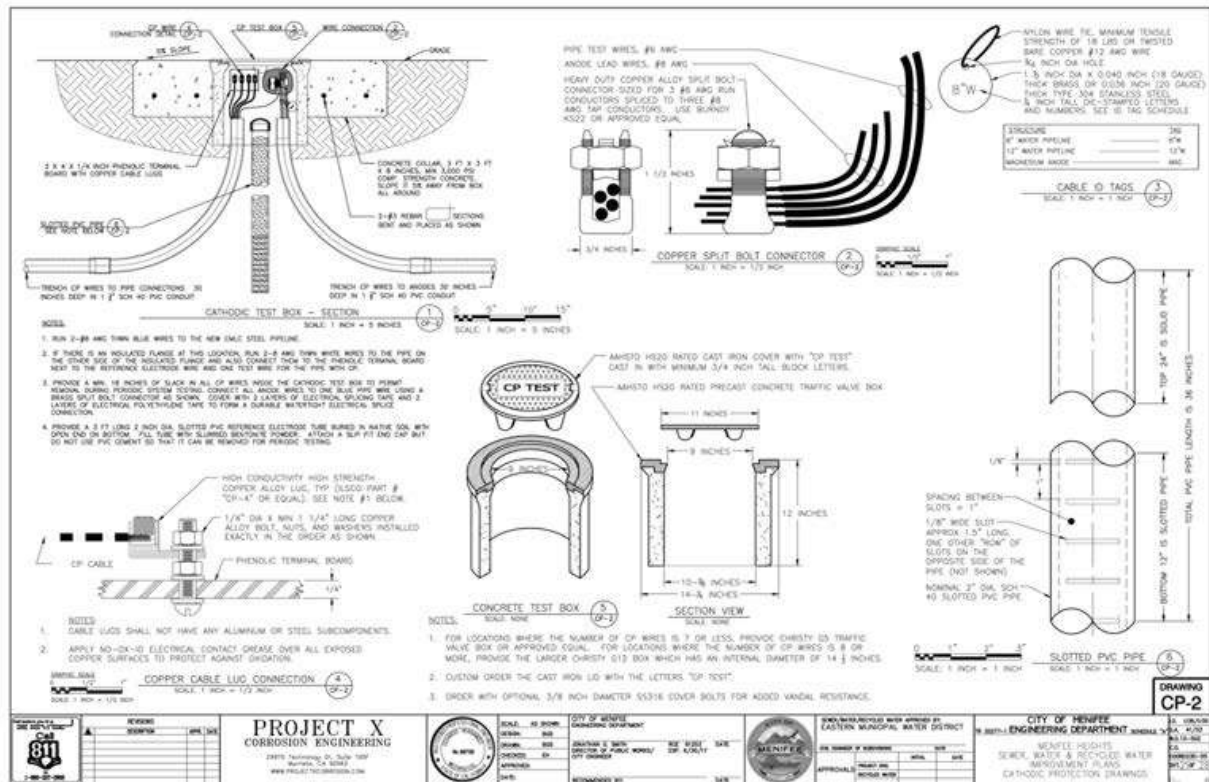

Figure 8 Sample of corrosion test station specification drawing

5.4.8 Excess Flux in Plumbing

Investigations of internal corrosion of domestic water plumbing systems almost always finds excess flux to be the cause of internal pitting of copper pipes. Some people believe that there is no such thing as too much flux. Flux runs have been observed to travel up to 20 feet with pitting occurring along the flux run. Flushing a soldered plumbing system with hot water for 15 minutes can remove significant amounts of excess flux left in the pipes. If a plumbing system is expected to be stagnant for some time, it should be drained to avoid stagnant water conditions that can lead to pitting and dezincification of yellow brasses.

5.4.9 Landscapers and Irrigation Sprinkler Systems

A significant amount of corrosion of fences is due to landscaper tools scratching fence coatings and irrigation sprinklers spraying these damaged fences. Recycled water typically has a higher salt content than potable drinking water, meaning that it is more corrosive than regular tap water. The same risk from damage and water spray exists for above ground pipe valves and backflow preventers. Fiber glass covers, cages, and cement footings have worked well to keep tools at an arm’s length.

5.4.10 Roof Drainage splash zones

Unbelievably, even the location where your roof drain splashes down can matter. We have seen drainage from a home’s roof valley fall directly down onto a gas meter causing it’s piping to corrode at an accelerated rate reaching 50% wall thickness within 4 years. It is the same effect as a splash

zone in the ocean or in a pool which has a lot of oxygen and agitation that can remove material as it corrodes.

5.4.11 Stray Current Sources

Stray currents which cause material loss when jumping off of metals may originate from direct-current distribution lines, substations, or street railway systems, etc., and flow into a pipe system or other steel structure. Alternating currents may occasionally cause corrosion. The corrosion resulting from stray currents (external sources) is similar to that from galvanic cells (which generate their own current) but different remedial measures may be indicated. In the electrolyte and at the metal-electrolyte interfaces, chemical and electrical reactions occur and are the same as those in the galvanic cell; specifically, the corroding metal is again considered to be the anode from which current leaves to flow to the cathode. Soil and water characteristics affect the corrosion rate in the same manner as with galvanic-type corrosion.

However, stray current strengths may be much higher than those produced by galvanic cells and, as a consequence, corrosion may be much more rapid. Another difference between galvanic-type currents and stray currents is that the latter are more likely to operate over long distances since the anode and cathode are more likely to be remotely separated from one another. Seeking the path of least resistance, the stray current from a foreign installation may travel along a pipeline causing severe corrosion where it leaves the line. Knowing when stray currents are present becomes highly important when remedial measures are undertaken since a simple sacrificial anode system is likely to be ineffectual in preventing corrosion under such circumstances.¹⁷ Stray currents can be avoided by installing proper electrical shielding, installation of isolation joints, or installation of sacrificial jump off anodes at crossings near protected structures such as metal gas pipelines or electrical feeders.

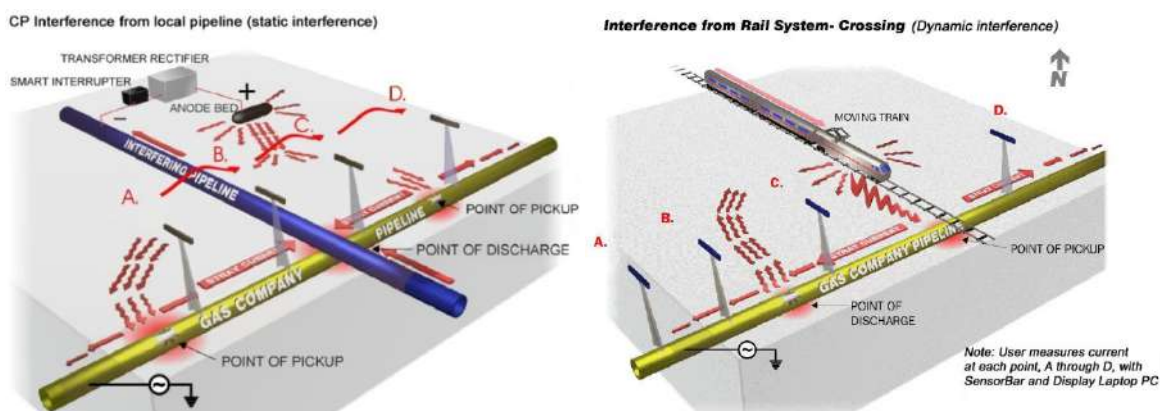

Figure 9 Examples of Stray Current¹⁸

¹⁷ <http://corrosion-doctors.org/StrayCurrent/Introduction.htm>

¹⁸ <http://www.eastcomassoc.com/>

JAVIER NUNEZ
VICE PRESIDENT

JOSELYN GEAGA-ROSENTHAL
LAUREL GILLETTE
GEORGE HOVAGUIMIAN
ELVIN W. MOON



ERIC GARCETTI
MAYOR

OSAMA YOUNAN, P.E.
GENERAL MANAGER
SUPERINTENDENT OF BUILDING

JOHN WEIGHT
EXECUTIVE OFFICER

SOILS REPORT APPROVAL LETTER

July 29, 2022

LOG # 122343
SOILS/GEOLOGY FILE - 2

Grubb Properties
4601 Park Road, Suite 450
Charlotte, NC 28209

TRACT: COLEGROVE (M R 53-10)
BLOCK: BLK 12
LOT(S): FR ARB 3-6, 8
LOCATION: 1200 -1218 N VINE ST, 6245 - 6247 W. LEXINGTON AVE.

<u>CURRENT REFERENCE</u> <u>REPORT/LETTER(S)</u>	<u>REPORT</u> <u>No.</u>	<u>DATE OF</u> <u>DOCUMENT</u>	<u>PREPARED BY</u>
Soils Report	22207	12/09/2021	Geotechnologies, Inc.

The Grading Division of the Department of Building and Safety has reviewed the referenced report that provides recommendations for the proposed 8-story mixed-use structure to be built at or near existing grade. The earth materials at the subsurface exploration locations consist of up to 3 feet of uncertified fill underlain by sand, silt and clay. The consultants recommend to support the proposed structure on conventional foundations bearing on minimum three feet of compacted fill.

The referenced report is acceptable, provided the following conditions are complied with during site development:

(Note: Numbers in parenthesis () refer to applicable sections of the 2020 City of LA Building Code. P/BC numbers refer the applicable Information Bulletin. Information Bulletins can be accessed on the internet at LADBS.ORG.)

1. The soils engineer shall review and approve the detailed plans prior to issuance of any permit. This approval shall be by signature on the plans that clearly indicates the soils engineer has reviewed the plans prepared by the design engineer; and, that the plans included the recommendations contained in their reports (7006.1).
2. All recommendations of the report that are in addition to or more restrictive than the conditions contained herein shall be incorporated into the plans.
3. A copy of the subject and appropriate referenced reports and this approval letter shall be attached to the District Office and field set of plans (7006.1). Submit one copy of the above reports to the Building Department Plan Checker prior to issuance of the permit.

4. A grading permit shall be obtained for all structural fill and retaining wall backfill (106.1.2).
5. All man-made fill shall be compacted to a minimum 90 percent of the maximum dry density of the fill material per the latest version of ASTM D 1557. Where cohesionless soil having less than 15 percent finer than 0.005 millimeters is used for fill, it shall be compacted to a minimum of 95 percent relative compaction based on maximum dry density. Placement of gravel in lieu of compacted fill is only allowed if complying with LAMC Section 91.7011.3.
6. If import soils are used, no footings shall be poured until the soils engineer has submitted a compaction report containing in-place shear test data and settlement data to the Grading Division of the Department; and, obtained approval (7008.2).
7. Compacted fill shall extend beyond the footings a minimum distance equal to the depth of the fill below the bottom of footings or a minimum of three feet whichever is greater (7011.3).
8. Existing uncertified fill shall not be used for support of footings, concrete slabs or new fill (1809.2, 7011.3).
9. Drainage in conformance with the provisions of the Code shall be maintained during and subsequent to construction (7013.12).
10. The applicant is advised that the approval of this report does not waive the requirements for excavations contained in the General Safety Orders of the California Department of Industrial Relations (3301.1).
11. Temporary excavations that remove lateral support to the public way, adjacent property, or adjacent structures shall be supported by shoring or constructed using ABC slot cuts. Note: Lateral support shall be considered to be removed when the excavation extends below a plane projected downward at an angle of 45 degrees from the bottom of a footing of an existing structure, from the edge of the public way or an adjacent property. (3307.3.1)
12. Prior to the issuance of any permit that authorizes an excavation where the excavation is to be of a greater depth than are the walls or foundation of any adjoining building or structure and located closer to the property line than the depth of the excavation, the owner of the subject site shall provide the Department with evidence that the adjacent property owner has been given a 30-day written notice of such intent to make an excavation (3307.1).
13. The soils engineer shall review and approve the shoring and/or underpinning plans prior to issuance of the permit (3307.3.2).
14. Prior to the issuance of the permits, the soils engineer and/or the structural designer shall evaluate the surcharge loads used in the report calculations for the design of the retaining walls and shoring. If the surcharge loads used in the calculations do not conform to the actual surcharge loads, the soil engineer shall submit a supplementary report with revised recommendations to the Department for approval.
15. Unsurcharged temporary excavation may be cut vertical up to 5 feet. Excavations over 5 feet to a maximum height of 15 feet shall be trimmed back at a uniform gradient not exceeding 1:1, from top to bottom of excavation, as recommended.

16. Shoring shall be designed for the lateral earth pressures specified in the section titled "Shoring Design" starting on page 30 of the 12/08/2021 report; all surcharge loads shall be included into the design.
17. Shoring shall be designed for a maximum lateral deflection of 1 inch, provided there are no structures within a 1:1 plane projected up from the base of the excavation. Where a structure is within a 1:1 plane projected up from the base of the excavation, shoring shall be designed for a maximum lateral deflection of ½ inch, or to a lower deflection determined by the consultant that does not present any potential hazard to the adjacent structure.
18. A shoring monitoring program shall be implemented to the satisfaction of the soils engineer.
19. Surcharged ABC slot-cut method may be used for temporary excavations with each slot-cut not exceeding 7 feet in height and not exceeding 8 feet in width, as recommended. The surcharge load shall not exceed the value given in the report. The soils engineer shall determine the clearance between the excavation and the existing foundation. The soils engineer shall verify in the field if the existing earth materials are stable in the slot-cut excavation. Each slot shall be inspected by the soils engineer and approved in writing prior to any worker access.
20. All foundations shall derive entire support from minimum three feet of compacted fill, as recommended and shall be approved by the geologist and soils engineer by inspection.
21. Footings supported on approved compacted fill or expansive soil shall be reinforced with a minimum of four (4), ½-inch diameter (#4) deformed reinforcing bars. Two (2) bars shall be placed near the bottom and two (2) bars placed near the top of the footing.
22. The foundation/slab design shall satisfy all requirements of the Information Bulletin P/BC 2017-116 "Foundation Design for Expansive Soils" (1803.5.3).
23. Slabs placed on approved compacted fill shall be at least 5 inches thick and shall be reinforced with ½-inch diameter (#4) reinforcing bars spaced a maximum of 16 inches on center each way.
24. Concrete floor slabs placed on expansive soil shall be placed on a 4-inch fill of coarse aggregate or on a moisture barrier membrane.
25. The seismic design shall be based on a Site Class D, as recommended. All other seismic design parameters shall be reviewed by LADBS building plan check.
26. Retaining walls shall be designed for the lateral earth pressures specified in the section titled "Retaining Wall Design" starting on page 23 of the 12/09/2021 report. All surcharge loads shall be included into the design.
27. All retaining walls shall be provided with a standard surface backdrain system and all drainage shall be conducted in a non-erosive device to the street in an acceptable manner (7013.11).
28. With the exception of retaining walls designed for hydrostatic pressure, all retaining walls shall be provided with a subdrain system to prevent possible hydrostatic pressure behind the wall. Prior to issuance of any permit, the retaining wall subdrain system recommended

1200 -1218 N VINE ST, 6245 - 6247 W. LEXINGTON AVE.

- in the soils report shall be incorporated into the foundation plan which shall be reviewed and approved by the soils engineer of record (1805.4).
29. Installation of the subdrain system shall be inspected and approved by the soils engineer of record and the City grading/building inspector (108.9).
 30. Prefabricated drainage composites (Miradrain, Geotextiles) may be only used in addition to traditionally accepted methods of draining retained earth.
 31. All roof, pad and deck drainage shall be conducted to the street in an acceptable manner in non-erosive devices or other approved location in a manner that is acceptable to the LADBS and the Department of Public Works (7013.10).
 32. An on-site storm water infiltration system at the subject site shall not be implemented, as recommended.
 33. All concentrated drainage shall be conducted in an approved device and disposed of in a manner approved by the LADBS (7013.10).
 34. The soils engineer shall inspect all excavations to determine that conditions anticipated in the report have been encountered and to provide recommendations for the correction of hazards found during grading (7008, 1705.6 & 1705.8).
 35. Prior to pouring concrete, a representative of the consulting soils engineer shall inspect and approve the footing excavations. The representative shall post a notice on the job site for the LADBS Inspector and the Contractor stating that the work inspected meets the conditions of the report. No concrete shall be poured until the LADBS Inspector has also inspected and approved the footing excavations. A written certification to this effect shall be filed with the Grading Division of the Department upon completion of the work. (108.9 & 7008.2)
 36. Prior to excavation an initial inspection shall be called with the LADBS Inspector. During the initial inspection, the sequence of construction; [shoring; ABC slot cuts; underpinning; pile installation;] protection fences; and, dust and traffic control will be scheduled (108.9.1).
 37. Installation of shoring, underpinning, slot cutting and/or pile excavations shall be performed under the inspection and approval of the soils engineer and deputy grading inspector (1705.6, 1705.8).
 38. Prior to the placing of compacted fill, a representative of the soils engineer shall inspect and approve the bottom excavations. The representative shall post a notice on the job site for the LADBS Inspector and the Contractor stating that the soil inspected meets the conditions of the report. No fill shall be placed until the LADBS Inspector has also inspected and approved the bottom excavations. A written certification to this effect shall be included in the final compaction report filed with the Grading Division of the Department. All fill shall be placed under the inspection and approval of the soils engineer. A compaction report together with the approved soil report and Department approval letter shall be submitted to the Grading Division of the Department upon completion of the compaction. In addition, an Engineer's Certificate of Compliance with the legal description as indicated in the grading permit and the permit number shall be included (7011.3).

1200 -1218 N VINE ST, 6245 - 6247 W. LEXINGTON AVE.

39. No footing/slab shall be poured until the compaction report is submitted and approved by the Grading Division of the Department.

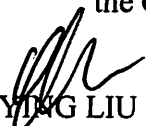

YING LIU

Geotechnical Engineer II

Log No. 122343
213-482-0480

cc: Geotechnologies, Inc., Project Consultant
LA District Office

APPLICATION FOR REVIEW OF TECHNICAL REPORTS

INSTRUCTIONS

- A. Address all communications to the Grading Division, LADBS, 221 N. Figueroa St., 12th Fl., Los Angeles, CA 90012
Telephone No. (213)482-0480.
- B. Submit two copies (three for subdivisions) of reports, one "pdf" copy of the report on a CD-Rom or flash drive, and one copy of application with items "1" through "10" completed.
- C. Check should be made to the City of Los Angeles.

1. LEGAL DESCRIPTION	2. PROJECT ADDRESS:
Tract: <u>COLEGROVE</u>	<u>1200 through 1218 N. Vine St., 645 and 647 W. Lexington Ave., LA</u>
Block: <u>Block 12</u> Lots: _____	4. APPLICANT <u>Geotechnologies, Inc.</u>
3. OWNER: <u>Grubb Properties</u>	Address: <u>439 Western Avenue</u>
Address: <u>4601 Park Road, Suite 450</u>	City: <u>Glendale, CA</u> Zip: <u>91201</u>
City: <u>Charlotte, NC</u> Zip: <u>28209</u>	Phone (Daytime): <u>818-240-9600</u>
Phone (Daytime): _____	E-mail address: <u>aalcocer@geoteq.com</u>

5. Report(s) Prepared by: Geotechnologies, Inc. File No. 22207 6. Report Date(s): December 9, 2021

7. Status of project: Proposed Under Construction Storm Damage

8. Previous site reports? YES if yes, give date(s) of report(s) and name of company who prepared report(s)
Geotechnologies, Inc.

9. Previous Department actions? YES if yes, provide dates and attach a copy to expedite processing.
Dates: _____

10. Applicant Signature: _____ Position: _____

(DEPARTMENT USE ONLY)

REVIEW REQUESTED	FEES	REVIEW REQUESTED	FEES
<input checked="" type="checkbox"/> Soils Engineering	<u>363.00</u>	No. of Lots	
<input type="checkbox"/> Geology		No. of Acres	
<input type="checkbox"/> Combined Soils Engr. & Geol.		<input type="checkbox"/> Division of Land	
<input type="checkbox"/> Supplemental		Other	
<input type="checkbox"/> Combined Supplemental		<input checked="" type="checkbox"/> Expedite	<u>181.50</u>
<input type="checkbox"/> Import-Export Route		<input type="checkbox"/> Response to Correction	
Cubic Yards: _____		<input type="checkbox"/> Expedite ONLY	
		Sub-total	<u>544.50</u>
		Surcharges	<u>29.80</u>
		TOTAL FEE	<u>674.30</u>

Fee Due: 674.30
Fee Verified By: Am Date: 7/16/22
(Cashier Use Only)

Receipt #
1369352

ACTION BY: _____

THE REPORT IS: NOT APPROVED
 APPROVED WITH CONDITIONS BELOW ATTACHED

_____	Date
For Geology	
_____	Date
For Soils	

As a covered entity under Title II of the Americans with Disabilities Act, the City of Los Angeles does not discriminate on the basis of disability and, upon request will provide reasonable accommodation to ensure equal access to its programs, services and activities.

Exhibit C – Maps

(Vicinity & Radius)

VICINITY MAP

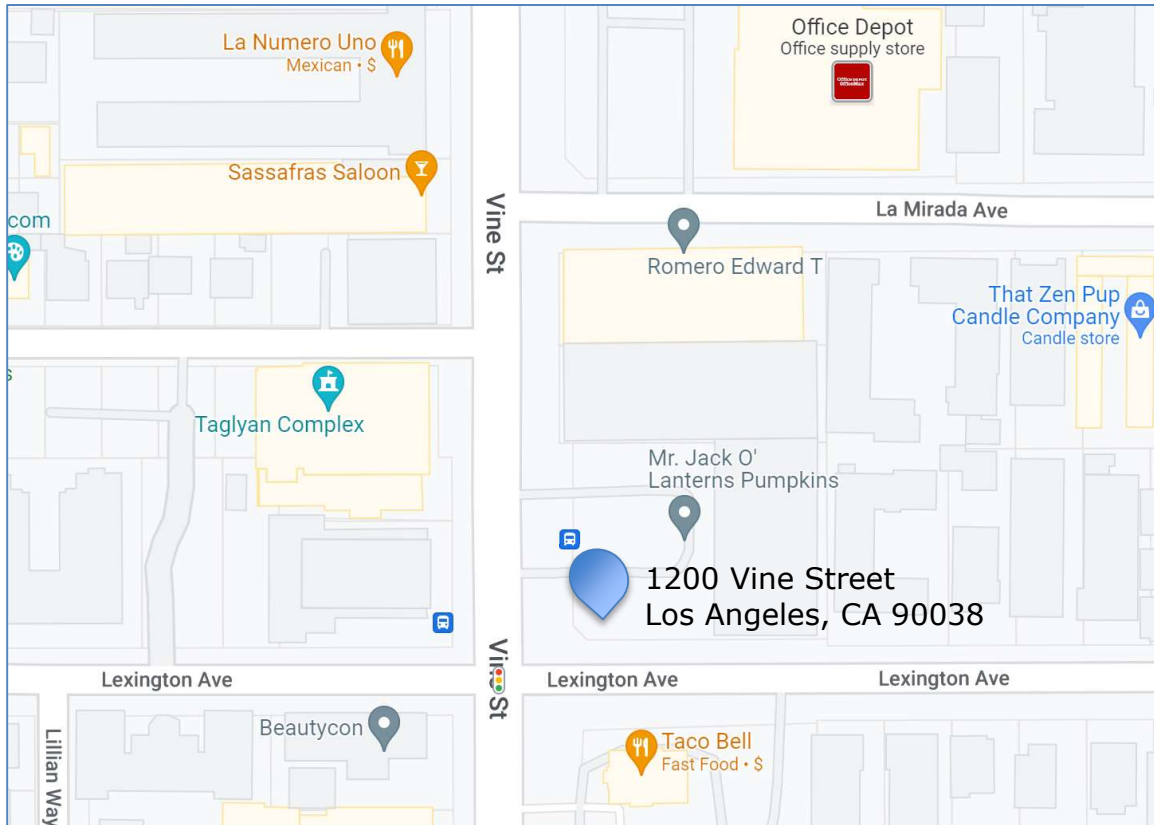

Primary Address: 1200 Vine Street, Los Angeles, CA 90038

Supplemental Addresses:
6245 W LEXINGTON AVE
6247 W LEXINGTON AVE
1204 VINE STREET
1214 VINE STREET
1218 VINE STREET

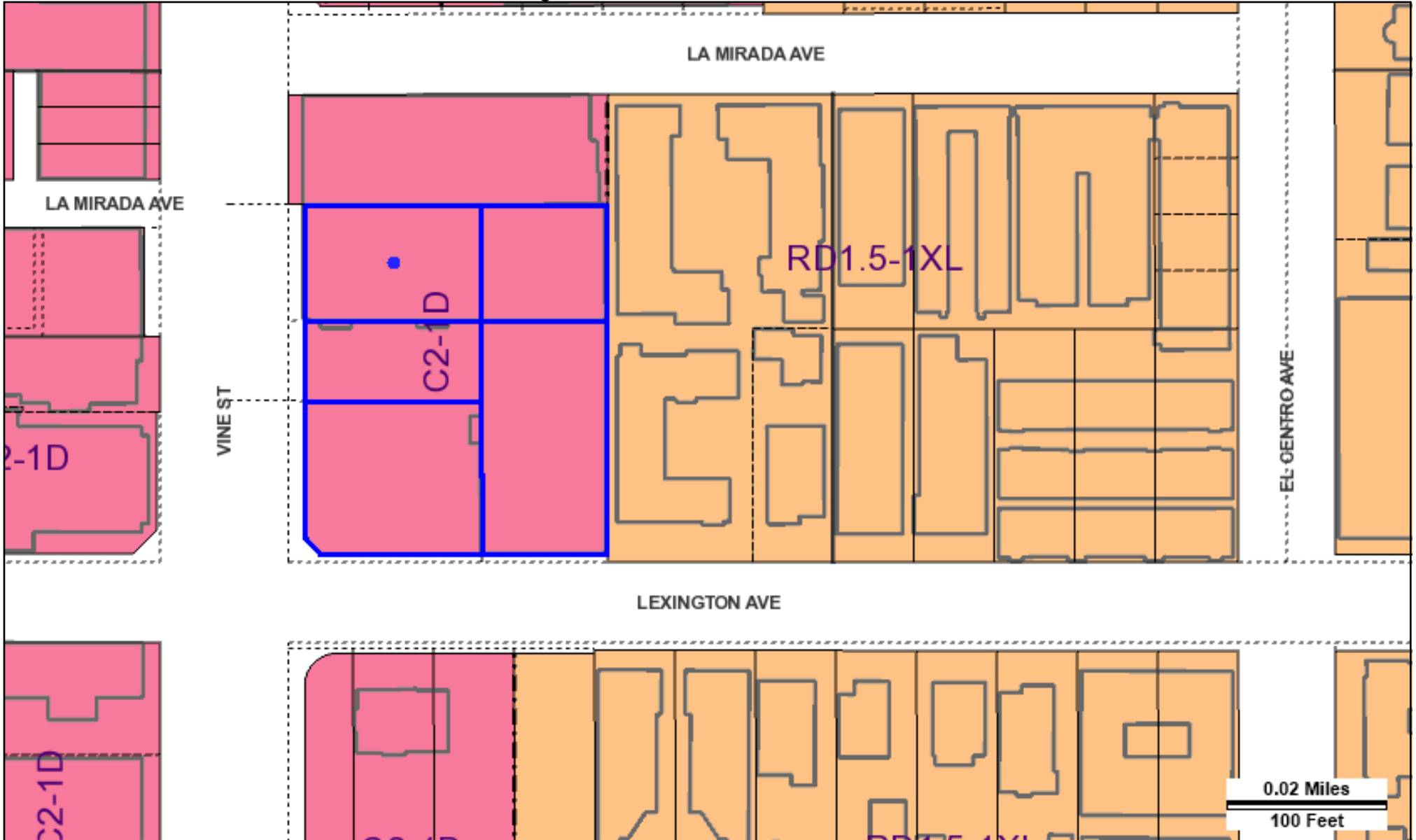

Address: 1218 N VINE ST
 APN: 5534002018
 PIN #: 144B189 297

Tract: COLEGROVE
 Block: BLK 12
 Lot: FR
 Arb: 6

Zoning: C2-1D
 General Plan: Highway Oriented Commercial





City of Los Angeles Department of City Planning

9/26/2022 PARCEL PROFILE REPORT

PROPERTY ADDRESSES

1218 N VINE ST
1214 N VINE ST

ZIP CODES

90038

RECENT ACTIVITY

None

CASE NUMBERS

CPC-2016-1450-CPU
CPC-2014-669-CPU
CPC-2005-6082
CPC-1997-43-CPU
CPC-1986-831-GPC
CPC-1984-1-HD
ORD-98865
ORD-182960
ORD-182173-SA19
ORD-164692
ORD-161116-SA19
ENV-2016-1451-EIR
ENV-2014-670-SE
ENV-2005-2158-EIR
MND-95-116-ZV
AFF-45525
PRIOR-06/01/1946

Address/Legal Information

PIN Number	144B189 297
Lot/Parcel Area (Calculated)	7,934.0 (sq ft)
Thomas Brothers Grid	PAGE 593 - GRID F5
Assessor Parcel No. (APN)	5534002018
Tract	COLEGROVE
Map Reference	M R 53-10
Block	BLK 12
Lot	FR
Arb (Lot Cut Reference)	6
Map Sheet	144B189

Jurisdictional Information

Community Plan Area	Hollywood
Area Planning Commission	Central
Neighborhood Council	Central Hollywood
Council District	CD 13 - Mitch O'Farrell
Census Tract #	1908.01
LADBS District Office	Los Angeles Metro

Permitting and Zoning Compliance Information

Administrative Review	None
-----------------------	------

Planning and Zoning Information

Special Notes	None
Zoning	C2-1D
Zoning Information (ZI)	ZI-2374 State Enterprise Zone: Los Angeles ZI-2498 Local Emergency Temporary Regulations - Time Limits and Parking Relief - LAMC 16.02.1 ZI-2433 Revised Hollywood Community Plan Injunction ZI-2452 Transit Priority Area in the City of Los Angeles
General Plan Land Use	Highway Oriented Commercial
General Plan Note(s)	Yes
Hillside Area (Zoning Code)	No
Specific Plan Area	None
Subarea	None
Special Land Use / Zoning	None
Historic Preservation Review	No
Historic Preservation Overlay Zone	None
Other Historic Designations	None
Other Historic Survey Information	None
Mills Act Contract	None
CDO: Community Design Overlay	None
CPIO: Community Plan Imp. Overlay	None
Subarea	None
CUGU: Clean Up-Green Up	None
HCR: Hillside Construction Regulation	No
NSO: Neighborhood Stabilization Overlay	No
POD: Pedestrian Oriented Districts	None
RBP: Restaurant Beverage Program Eligible Area	General (RBPA)

This report is subject to the terms and conditions as set forth on the website. For more details, please refer to the terms and conditions at zimas.lacity.org
(*) - APN Area is provided "as is" from the Los Angeles County's Public Works, Flood Control, Benefit Assessment.

RFA: Residential Floor Area District	None
RIO: River Implementation Overlay	No
SN: Sign District	No
Streetscape	No
Adaptive Reuse Incentive Area	None
Affordable Housing Linkage Fee	
Residential Market Area	Medium-High
Non-Residential Market Area	High
Transit Oriented Communities (TOC)	Tier 1
RPA: Redevelopment Project Area	None
Central City Parking	No
Downtown Parking	No
Building Line	None
500 Ft School Zone	No
500 Ft Park Zone	No

Assessor Information

Assessor Parcel No. (APN)	5534002018
APN Area (Co. Public Works)*	0.327 (ac)
Use Code	1100 - Commercial - Store - One Story
Assessed Land Val.	\$598,779
Assessed Improvement Val.	\$0
Last Owner Change	12/30/2021
Last Sale Amount	\$17,000,170
Tax Rate Area	67
Deed Ref No. (City Clerk)	774613
	4-995
	240869-70
	1697228
	1667997
	1369936
	1136061
	1130389

Building 1

Year Built	1980
Building Class	C6B
Number of Units	1
Number of Bedrooms	0
Number of Bathrooms	0
Building Square Footage	13,536.0 (sq ft)
Building 2	No data for building 2
Building 3	No data for building 3
Building 4	No data for building 4
Building 5	No data for building 5
Rent Stabilization Ordinance (RSO)	No [APN: 5534002018]

Additional Information

Airport Hazard	None
Coastal Zone	None
Farmland	Area Not Mapped
Urban Agriculture Incentive Zone	YES
Very High Fire Hazard Severity Zone	No
Fire District No. 1	No
Flood Zone	Outside Flood Zone
Watercourse	No
Hazardous Waste / Border Zone Properties	No
Methane Hazard Site	None

This report is subject to the terms and conditions as set forth on the website. For more details, please refer to the terms and conditions at zimas.lacity.org
 (*) - APN Area is provided "as is" from the Los Angeles County's Public Works, Flood Control, Benefit Assessment.

High Wind Velocity Areas	No
Special Grading Area (BOE Basic Grid Map A-13372)	No
Wells	None

Seismic Hazards

Active Fault Near-Source Zone	
Nearest Fault (Distance in km)	1.64265864
Nearest Fault (Name)	Hollywood Fault
Region	Transverse Ranges and Los Angeles Basin
Fault Type	B
Slip Rate (mm/year)	1.00000000
Slip Geometry	Left Lateral - Reverse - Oblique
Slip Type	Poorly Constrained
Down Dip Width (km)	14.00000000
Rupture Top	0.00000000
Rupture Bottom	13.00000000
Dip Angle (degrees)	70.00000000
Maximum Magnitude	6.40000000
Alquist-Priolo Fault Zone	No
Landslide	No
Liquefaction	No
Preliminary Fault Rupture Study Area	No
Tsunami Inundation Zone	No

Economic Development Areas

Business Improvement District	HOLLYWOOD ENTERTAINMENT DISTRICT
Hubzone	Qualified
Jobs and Economic Development Incentive Zone (JEDI)	None
Opportunity Zone	Yes
Promise Zone	Los Angeles
State Enterprise Zone	LOS ANGELES STATE ENTERPRISE ZONE

Housing

Direct all Inquiries to	Los Angeles Housing Department
Telephone	(866) 557-7368
Website	https://housing.lacity.org
Rent Stabilization Ordinance (RSO)	No [APN: 5534002018]
Ellis Act Property	No
AB 1482: Tenant Protection Act	No
Housing Crisis Act Replacement Review	Yes

Public Safety

Police Information	
Bureau	West
Division / Station	Hollywood
Reporting District	666
Fire Information	
Bureau	West
Battalion	5
District / Fire Station	27
Red Flag Restricted Parking	No

CASE SUMMARIES

Note: Information for case summaries is retrieved from the Planning Department's Plan Case Tracking System (PCTS) database.

Case Number:	CPC-2016-1450-CPU
Required Action(s):	CPU-COMMUNITY PLAN UPDATE
Project Descriptions(s):	UPDATE TO THE HOLLYWOOD COMMUNITY PLAN
Case Number:	CPC-2014-669-CPU
Required Action(s):	CPU-COMMUNITY PLAN UPDATE
Project Descriptions(s):	COMMUNITY PLAN UPDATE/GENERAL PLAN AMENDMENT
Case Number:	CPC-2005-6082
Required Action(s):	Data Not Available
Project Descriptions(s):	HOLLYWOOD COMMUNITY PLAN UPDATE
Case Number:	CPC-1997-43-CPU
Required Action(s):	CPU-COMMUNITY PLAN UPDATE
Project Descriptions(s):	COMMUNITY PLAN UPDATE FOR HOLLYWOOD WHICH IDENTIFIES AND REDEFINES OUTDATED LAND USE ISSUES AND INCONSISTENT ZONING, REVIEWS POLICIES AND PROGRAMS, AS WELL AS REVISING AND UPDATING THE PLAN MAP AND TEXT
Case Number:	CPC-1986-831-GPC
Required Action(s):	GPC-GENERAL PLAN/ZONING CONSISTENCY (AB283)
Project Descriptions(s):	HOLLYWOOD COMMUNITY PLAN REVISION/GENERAL PLAN CONSISTENCY PLAN AMENDMENT, ZONE CHANGES AND HEIGHT DISTRICT CHANGES
Case Number:	CPC-1984-1-HD
Required Action(s):	HD-HEIGHT DISTRICT
Project Descriptions(s):	CHANGE OF HEIGHT DISTRICT WITHIN THE "CORE AREA OF L.A."- GENERAL PLAN ZONE CONSISTENCY PROGRAM.
Case Number:	ENV-2016-1451-EIR
Required Action(s):	EIR-ENVIRONMENTAL IMPACT REPORT
Project Descriptions(s):	UPDATE TO THE HOLLYWOOD COMMUNITY PLAN
Case Number:	ENV-2014-670-SE
Required Action(s):	SE-STATUTORY EXEMPTIONS
Project Descriptions(s):	COMMUNITY PLAN UPDATE/GENERAL PLAN AMENDMENT
Case Number:	ENV-2005-2158-EIR
Required Action(s):	EIR-ENVIRONMENTAL IMPACT REPORT
Project Descriptions(s):	COMMUNITY PLAN UPDATE FOR HOLLYWOOD WHICH IDENTIFIES AND REDEFINES OUTDATED LAND USE ISSUES AND INCONSISTENT ZONING, REVIEWS POLICIES AND PROGRAMS, AS WELL AS REVISING AND UPDATING THE PLAN MAP AND TEXT
Case Number:	MND-95-116-ZV
Required Action(s):	ZV-ZONE VARIANCE
Project Descriptions(s):	Data Not Available

DATA NOT AVAILABLE

ORD-98865
ORD-182960
ORD-182173-SA19
ORD-164692
ORD-161116-SA19
AFF-45525
PRIOR-06/01/1946

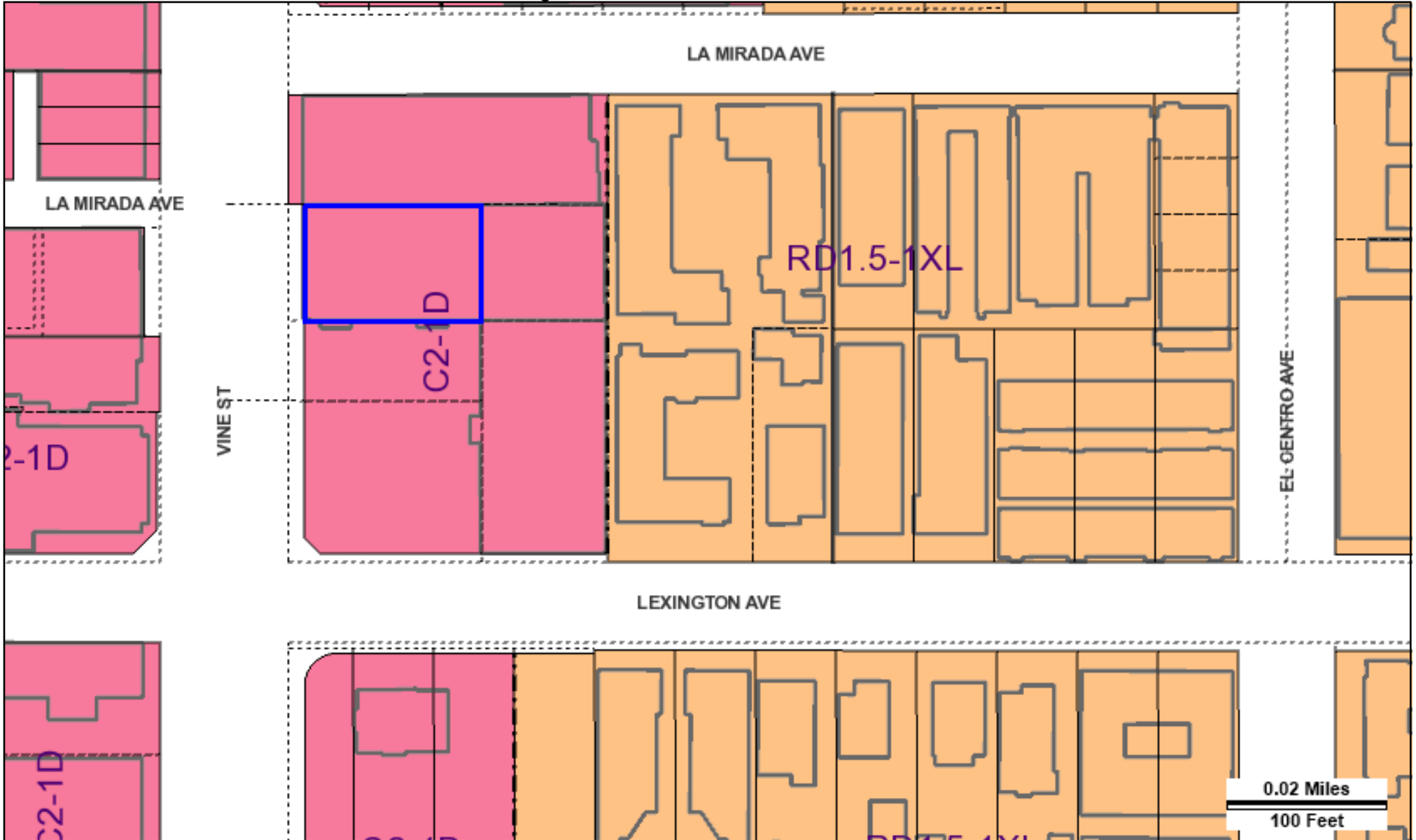

Address: 1218 N VINE ST
 APN: 5534002018
 PIN #: 144B189 297

Tract: COLEGROVE
 Block: BLK 12
 Lot: FR
 Arb: 6

Zoning: C2-1D
 General Plan: Highway Oriented Commercial





City of Los Angeles Department of City Planning

9/26/2022 PARCEL PROFILE REPORT

PROPERTY ADDRESSES

None

ZIP CODES

None

RECENT ACTIVITY

None

CASE NUMBERS

CPC-2016-1450-CPU
CPC-2014-669-CPU
CPC-2005-6082
CPC-1997-43-CPU
CPC-1986-831-GPC
CPC-1984-1-HD
ORD-182960
ORD-182173-SA19
ORD-164692
ORD-161116-SA19
ENV-2016-1451-EIR
ENV-2014-670-SE
ENV-2005-2158-EIR
MND-95-116-ZV
AFF-45525
PRIOR-06/01/1946

Address/Legal Information

PIN Number	144B189 296
Lot/Parcel Area (Calculated)	5,616.0 (sq ft)
Thomas Brothers Grid	PAGE 593 - GRID F5
Assessor Parcel No. (APN)	5534002018
Tract	COLEGROVE
Map Reference	M R 53-10
Block	BLK 12
Lot	FR
Arb (Lot Cut Reference)	8
Map Sheet	144B189

Jurisdictional Information

Community Plan Area	Hollywood
Area Planning Commission	Central
Neighborhood Council	Central Hollywood
Council District	CD 13 - Mitch O'Farrell
Census Tract #	1908.01
LADBS District Office	Los Angeles Metro

Permitting and Zoning Compliance Information

Administrative Review	None
-----------------------	------

Planning and Zoning Information

Special Notes	None
Zoning	C2-1D
Zoning Information (ZI)	ZI-2374 State Enterprise Zone: Los Angeles ZI-2498 Local Emergency Temporary Regulations - Time Limits and Parking Relief - LAMC 16.02.1 ZI-2433 Revised Hollywood Community Plan Injunction ZI-2452 Transit Priority Area in the City of Los Angeles
General Plan Land Use	Highway Oriented Commercial
General Plan Note(s)	Yes
Hillside Area (Zoning Code)	No
Specific Plan Area	None
Subarea	None
Special Land Use / Zoning	None
Historic Preservation Review	No
Historic Preservation Overlay Zone	None
Other Historic Designations	None
Other Historic Survey Information	None
Mills Act Contract	None
CDO: Community Design Overlay	None
CPIO: Community Plan Imp. Overlay	None
Subarea	None
CUGU: Clean Up-Green Up	None
HCR: Hillside Construction Regulation	No
NSO: Neighborhood Stabilization Overlay	No
POD: Pedestrian Oriented Districts	None
RBP: Restaurant Beverage Program Eligible Area	General (RBPA)

This report is subject to the terms and conditions as set forth on the website. For more details, please refer to the terms and conditions at zimas.lacity.org
(*) - APN Area is provided "as is" from the Los Angeles County's Public Works, Flood Control, Benefit Assessment.

RFA: Residential Floor Area District	None
RIO: River Implementation Overlay	No
SN: Sign District	No
Streetscape	No
Adaptive Reuse Incentive Area	None
Affordable Housing Linkage Fee	
Residential Market Area	Medium-High
Non-Residential Market Area	High
Transit Oriented Communities (TOC)	Tier 1
RPA: Redevelopment Project Area	None
Central City Parking	No
Downtown Parking	No
Building Line	None
500 Ft School Zone	No
500 Ft Park Zone	No

Assessor Information

Assessor Parcel No. (APN)	5534002018
APN Area (Co. Public Works)*	0.327 (ac)
Use Code	1100 - Commercial - Store - One Story
Assessed Land Val.	\$598,779
Assessed Improvement Val.	\$0
Last Owner Change	12/30/2021
Last Sale Amount	\$17,000,170
Tax Rate Area	67
Deed Ref No. (City Clerk)	774613
	4-995
	240869-70
	1697228
	1667997
	1369936
	1136061
	1130389

Building 1

Year Built	1980
Building Class	C6B
Number of Units	1
Number of Bedrooms	0
Number of Bathrooms	0
Building Square Footage	13,536.0 (sq ft)
Building 2	No data for building 2
Building 3	No data for building 3
Building 4	No data for building 4
Building 5	No data for building 5
Rent Stabilization Ordinance (RSO)	No [APN: 5534002018]

Additional Information

Airport Hazard	None
Coastal Zone	None
Farmland	Area Not Mapped
Urban Agriculture Incentive Zone	YES
Very High Fire Hazard Severity Zone	No
Fire District No. 1	No
Flood Zone	Outside Flood Zone
Watercourse	No
Hazardous Waste / Border Zone Properties	No
Methane Hazard Site	None

This report is subject to the terms and conditions as set forth on the website. For more details, please refer to the terms and conditions at zimas.lacity.org
 (*) - APN Area is provided "as is" from the Los Angeles County's Public Works, Flood Control, Benefit Assessment.

High Wind Velocity Areas	No
Special Grading Area (BOE Basic Grid Map A-13372)	No
Wells	None

Seismic Hazards

Active Fault Near-Source Zone	
Nearest Fault (Distance in km)	1.65061392
Nearest Fault (Name)	Hollywood Fault
Region	Transverse Ranges and Los Angeles Basin
Fault Type	B
Slip Rate (mm/year)	1.00000000
Slip Geometry	Left Lateral - Reverse - Oblique
Slip Type	Poorly Constrained
Down Dip Width (km)	14.00000000
Rupture Top	0.00000000
Rupture Bottom	13.00000000
Dip Angle (degrees)	70.00000000
Maximum Magnitude	6.40000000
Alquist-Priolo Fault Zone	No
Landslide	No
Liquefaction	No
Preliminary Fault Rupture Study Area	No
Tsunami Inundation Zone	No

Economic Development Areas

Business Improvement District	HOLLYWOOD ENTERTAINMENT DISTRICT
Hubzone	Qualified
Jobs and Economic Development Incentive Zone (JEDI)	None
Opportunity Zone	Yes
Promise Zone	Los Angeles
State Enterprise Zone	LOS ANGELES STATE ENTERPRISE ZONE

Housing

Direct all Inquiries to	Los Angeles Housing Department
Telephone	(866) 557-7368
Website	https://housing.lacity.org
Rent Stabilization Ordinance (RSO)	No [APN: 5534002018]
Ellis Act Property	No
AB 1482: Tenant Protection Act	No
Housing Crisis Act Replacement Review	Yes

Public Safety

Police Information	
Bureau	West
Division / Station	Hollywood
Reporting District	666
Fire Information	
Bureau	West
Battalion	5
District / Fire Station	27
Red Flag Restricted Parking	No

CASE SUMMARIES

Note: Information for case summaries is retrieved from the Planning Department's Plan Case Tracking System (PCTS) database.

Case Number:	CPC-2016-1450-CPU
Required Action(s):	CPU-COMMUNITY PLAN UPDATE
Project Descriptions(s):	UPDATE TO THE HOLLYWOOD COMMUNITY PLAN
Case Number:	CPC-2014-669-CPU
Required Action(s):	CPU-COMMUNITY PLAN UPDATE
Project Descriptions(s):	COMMUNITY PLAN UPDATE/GENERAL PLAN AMENDMENT
Case Number:	CPC-2005-6082
Required Action(s):	Data Not Available
Project Descriptions(s):	HOLLYWOOD COMMUNITY PLAN UPDATE
Case Number:	CPC-1997-43-CPU
Required Action(s):	CPU-COMMUNITY PLAN UPDATE
Project Descriptions(s):	COMMUNITY PLAN UPDATE FOR HOLLYWOOD WHICH IDENTIFIES AND REDEFINES OUTDATED LAND USE ISSUES AND INCONSISTENT ZONING, REVIEWS POLICIES AND PROGRAMS, AS WELL AS REVISING AND UPDATING THE PLAN MAP AND TEXT
Case Number:	CPC-1986-831-GPC
Required Action(s):	GPC-GENERAL PLAN/ZONING CONSISTENCY (AB283)
Project Descriptions(s):	HOLLYWOOD COMMUNITY PLAN REVISION/GENERAL PLAN CONSISTENCY PLAN AMENDMENT, ZONE CHANGES AND HEIGHT DISTRICT CHANGES
Case Number:	CPC-1984-1-HD
Required Action(s):	HD-HEIGHT DISTRICT
Project Descriptions(s):	CHANGE OF HEIGHT DISTRICT WITHIN THE "CORE AREA OF L.A."- GENERAL PLAN ZONE CONSISTENCY PROGRAM.
Case Number:	ENV-2016-1451-EIR
Required Action(s):	EIR-ENVIRONMENTAL IMPACT REPORT
Project Descriptions(s):	UPDATE TO THE HOLLYWOOD COMMUNITY PLAN
Case Number:	ENV-2014-670-SE
Required Action(s):	SE-STATUTORY EXEMPTIONS
Project Descriptions(s):	COMMUNITY PLAN UPDATE/GENERAL PLAN AMENDMENT
Case Number:	ENV-2005-2158-EIR
Required Action(s):	EIR-ENVIRONMENTAL IMPACT REPORT
Project Descriptions(s):	COMMUNITY PLAN UPDATE FOR HOLLYWOOD WHICH IDENTIFIES AND REDEFINES OUTDATED LAND USE ISSUES AND INCONSISTENT ZONING, REVIEWS POLICIES AND PROGRAMS, AS WELL AS REVISING AND UPDATING THE PLAN MAP AND TEXT
Case Number:	MND-95-116-ZV
Required Action(s):	ZV-ZONE VARIANCE
Project Descriptions(s):	Data Not Available

DATA NOT AVAILABLE

ORD-182960
ORD-182173-SA19
ORD-164692
ORD-161116-SA19
AFF-45525
PRIOR-06/01/1946

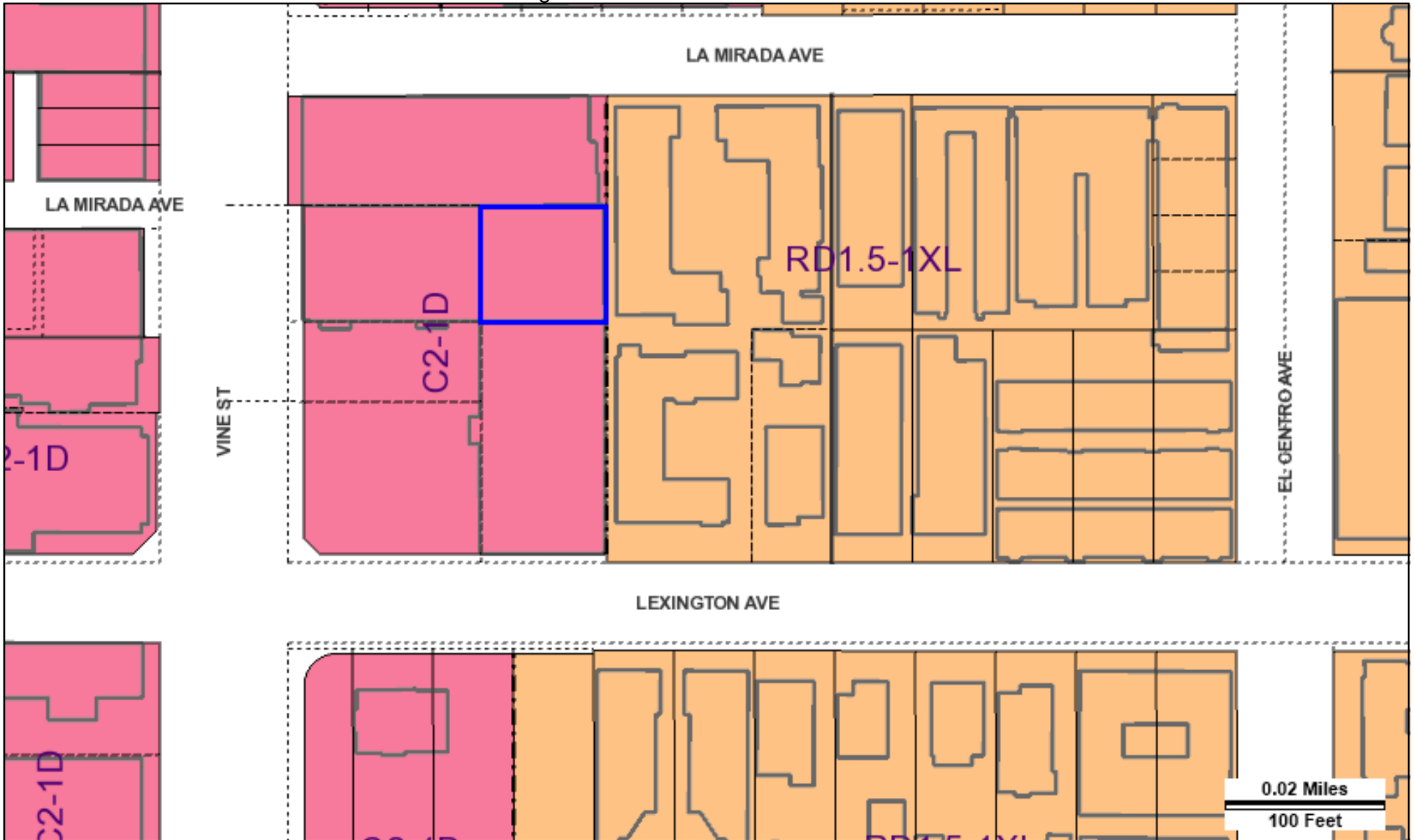

Address: undefined
 APN: 5534002018
 PIN #: 144B189 296

Tract: COLEGROVE
 Block: BLK 12
 Lot: FR
 Arb: 8

Zoning: C2-1D
 General Plan: Highway Oriented Commercial





City of Los Angeles Department of City Planning

9/26/2022 PARCEL PROFILE REPORT

PROPERTY ADDRESSES

None

ZIP CODES

None

RECENT ACTIVITY

None

CASE NUMBERS

CPC-2016-1450-CPU
CPC-2014-669-CPU
CPC-2005-6082
CPC-1997-43-CPU
CPC-1986-831-GPC
CPC-1984-1-HD
ORD-98865
ORD-182960
ORD-182173-SA19
ORD-164692
ORD-161116-SA19
ZA-19XX-8370
ZA-14237
ZA-11663
ENV-2016-1451-EIR
ENV-2014-670-SE
ENV-2005-2158-EIR
AFF-44439-A
AFF-28153

Address/Legal Information

PIN Number	144B189 322
Lot/Parcel Area (Calculated)	5,509.0 (sq ft)
Thomas Brothers Grid	PAGE 593 - GRID F5
Assessor Parcel No. (APN)	5534002023
Tract	COLEGROVE
Map Reference	M R 53-10
Block	BLK 12
Lot	FR
Arb (Lot Cut Reference)	5
Map Sheet	144B189

Jurisdictional Information

Community Plan Area	Hollywood
Area Planning Commission	Central
Neighborhood Council	Central Hollywood
Council District	CD 13 - Mitch O'Farrell
Census Tract #	1908.01
LADBS District Office	Los Angeles Metro

Permitting and Zoning Compliance Information

Administrative Review	None
-----------------------	------

Planning and Zoning Information

Special Notes	None
Zoning	C2-1D
Zoning Information (ZI)	ZI-2374 State Enterprise Zone: Los Angeles ZI-2498 Local Emergency Temporary Regulations - Time Limits and Parking Relief - LAMC 16.02.1 ZI-2433 Revised Hollywood Community Plan Injunction ZI-2452 Transit Priority Area in the City of Los Angeles
General Plan Land Use	Highway Oriented Commercial
General Plan Note(s)	Yes
Hillside Area (Zoning Code)	No
Specific Plan Area	None
Subarea	None
Special Land Use / Zoning	None
Historic Preservation Review	No
Historic Preservation Overlay Zone	None
Other Historic Designations	None
Other Historic Survey Information	None
Mills Act Contract	None
CDO: Community Design Overlay	None
CPIO: Community Plan Imp. Overlay	None
Subarea	None
CUGU: Clean Up-Green Up	None
HCR: Hillside Construction Regulation	No
NSO: Neighborhood Stabilization Overlay	No
POD: Pedestrian Oriented Districts	None
RBP: Restaurant Beverage Program Eligible Area	General (RBPA)

This report is subject to the terms and conditions as set forth on the website. For more details, please refer to the terms and conditions at zimas.lacity.org
(*) - APN Area is provided "as is" from the Los Angeles County's Public Works, Flood Control, Benefit Assessment.

RFA: Residential Floor Area District	None
RIO: River Implementation Overlay	No
SN: Sign District	No
Streetscape	No
Adaptive Reuse Incentive Area	None
Affordable Housing Linkage Fee	
Residential Market Area	Medium-High
Non-Residential Market Area	High
Transit Oriented Communities (TOC)	Tier 1
RPA: Redevelopment Project Area	None
Central City Parking	No
Downtown Parking	No
Building Line	None
500 Ft School Zone	No
500 Ft Park Zone	No

Assessor Information

Assessor Parcel No. (APN)	5534002023
APN Area (Co. Public Works)*	0.623 (ac)
Use Code	1100 - Commercial - Store - One Story
Assessed Land Val.	\$764,661
Assessed Improvement Val.	\$0
Last Owner Change	12/30/2021
Last Sale Amount	\$17,000,170
Tax Rate Area	67
Deed Ref No. (City Clerk)	774614
	5-887
	240867-8
	1697229
	1667998
	1369937
	1136078
	1130390

Building 1

Year Built	1992
Building Class	C6A
Number of Units	1
Number of Bedrooms	0
Number of Bathrooms	0
Building Square Footage	13,475.0 (sq ft)

Building 2 No data for building 2

Building 3 No data for building 3

Building 4 No data for building 4

Building 5 No data for building 5

Rent Stabilization Ordinance (RSO) No [APN: 5534002023]

Additional Information

Airport Hazard	None
Coastal Zone	None
Farmland	Area Not Mapped
Urban Agriculture Incentive Zone	YES
Very High Fire Hazard Severity Zone	No
Fire District No. 1	No
Flood Zone	Outside Flood Zone
Watercourse	No
Hazardous Waste / Border Zone Properties	No
Methane Hazard Site	None

This report is subject to the terms and conditions as set forth on the website. For more details, please refer to the terms and conditions at zimas.lacity.org
 (*) - APN Area is provided "as is" from the Los Angeles County's Public Works, Flood Control, Benefit Assessment.

High Wind Velocity Areas	No
Special Grading Area (BOE Basic Grid Map A-13372)	No
Wells	None

Seismic Hazards

Active Fault Near-Source Zone	
Nearest Fault (Distance in km)	1.66399464
Nearest Fault (Name)	Hollywood Fault
Region	Transverse Ranges and Los Angeles Basin
Fault Type	B
Slip Rate (mm/year)	1.00000000
Slip Geometry	Left Lateral - Reverse - Oblique
Slip Type	Poorly Constrained
Down Dip Width (km)	14.00000000
Rupture Top	0.00000000
Rupture Bottom	13.00000000
Dip Angle (degrees)	70.00000000
Maximum Magnitude	6.40000000
Alquist-Priolo Fault Zone	No
Landslide	No
Liquefaction	No
Preliminary Fault Rupture Study Area	No
Tsunami Inundation Zone	No

Economic Development Areas

Business Improvement District	HOLLYWOOD ENTERTAINMENT DISTRICT
Hubzone	Qualified
Jobs and Economic Development Incentive Zone (JEDI)	None
Opportunity Zone	Yes
Promise Zone	Los Angeles
State Enterprise Zone	LOS ANGELES STATE ENTERPRISE ZONE

Housing

Direct all Inquiries to	Los Angeles Housing Department
Telephone	(866) 557-7368
Website	https://housing.lacity.org
Rent Stabilization Ordinance (RSO)	No [APN: 5534002023]
Ellis Act Property	No
AB 1482: Tenant Protection Act	No
Housing Crisis Act Replacement Review	Yes

Public Safety

Police Information	
Bureau	West
Division / Station	Hollywood
Reporting District	666
Fire Information	
Bureau	West
Battalion	5
District / Fire Station	27
Red Flag Restricted Parking	No

CASE SUMMARIES

Note: Information for case summaries is retrieved from the Planning Department's Plan Case Tracking System (PCTS) database.

Case Number:	CPC-2016-1450-CPU
Required Action(s):	CPU-COMMUNITY PLAN UPDATE
Project Descriptions(s):	UPDATE TO THE HOLLYWOOD COMMUNITY PLAN
Case Number:	CPC-2014-669-CPU
Required Action(s):	CPU-COMMUNITY PLAN UPDATE
Project Descriptions(s):	COMMUNITY PLAN UPDATE/GENERAL PLAN AMENDMENT
Case Number:	CPC-2005-6082
Required Action(s):	Data Not Available
Project Descriptions(s):	HOLLYWOOD COMMUNITY PLAN UPDATE
Case Number:	CPC-1997-43-CPU
Required Action(s):	CPU-COMMUNITY PLAN UPDATE
Project Descriptions(s):	COMMUNITY PLAN UPDATE FOR HOLLYWOOD WHICH IDENTIFIES AND REDEFINES OUTDATED LAND USE ISSUES AND INCONSISTENT ZONING, REVIEWS POLICIES AND PROGRAMS, AS WELL AS REVISING AND UPDATING THE PLAN MAP AND TEXT
Case Number:	CPC-1986-831-GPC
Required Action(s):	GPC-GENERAL PLAN/ZONING CONSISTENCY (AB283)
Project Descriptions(s):	HOLLYWOOD COMMUNITY PLAN REVISION/GENERAL PLAN CONSISTENCY PLAN AMENDMENT, ZONE CHANGES AND HEIGHT DISTRICT CHANGES
Case Number:	CPC-1984-1-HD
Required Action(s):	HD-HEIGHT DISTRICT
Project Descriptions(s):	CHANGE OF HEIGHT DISTRICT WITHIN THE "CORE AREA OF L.A."- GENERAL PLAN ZONE CONSISTENCY PROGRAM.
Case Number:	ZA-19XX-8370
Required Action(s):	Data Not Available
Project Descriptions(s):	
Case Number:	ENV-2016-1451-EIR
Required Action(s):	EIR-ENVIRONMENTAL IMPACT REPORT
Project Descriptions(s):	UPDATE TO THE HOLLYWOOD COMMUNITY PLAN
Case Number:	ENV-2014-670-SE
Required Action(s):	SE-STATUTORY EXEMPTIONS
Project Descriptions(s):	COMMUNITY PLAN UPDATE/GENERAL PLAN AMENDMENT
Case Number:	ENV-2005-2158-EIR
Required Action(s):	EIR-ENVIRONMENTAL IMPACT REPORT
Project Descriptions(s):	COMMUNITY PLAN UPDATE FOR HOLLYWOOD WHICH IDENTIFIES AND REDEFINES OUTDATED LAND USE ISSUES AND INCONSISTENT ZONING, REVIEWS POLICIES AND PROGRAMS, AS WELL AS REVISING AND UPDATING THE PLAN MAP AND TEXT
Case Number:	AFF-44439-A
Required Action(s):	A-PRIVATE STREET MODIFICATIONS (1ST REQUEST)
Project Descriptions(s):	Data Not Available

DATA NOT AVAILABLE

ORD-98865
ORD-182960
ORD-182173-SA19
ORD-164692
ORD-161116-SA19
ZA-14237
ZA-11663
AFF-28153

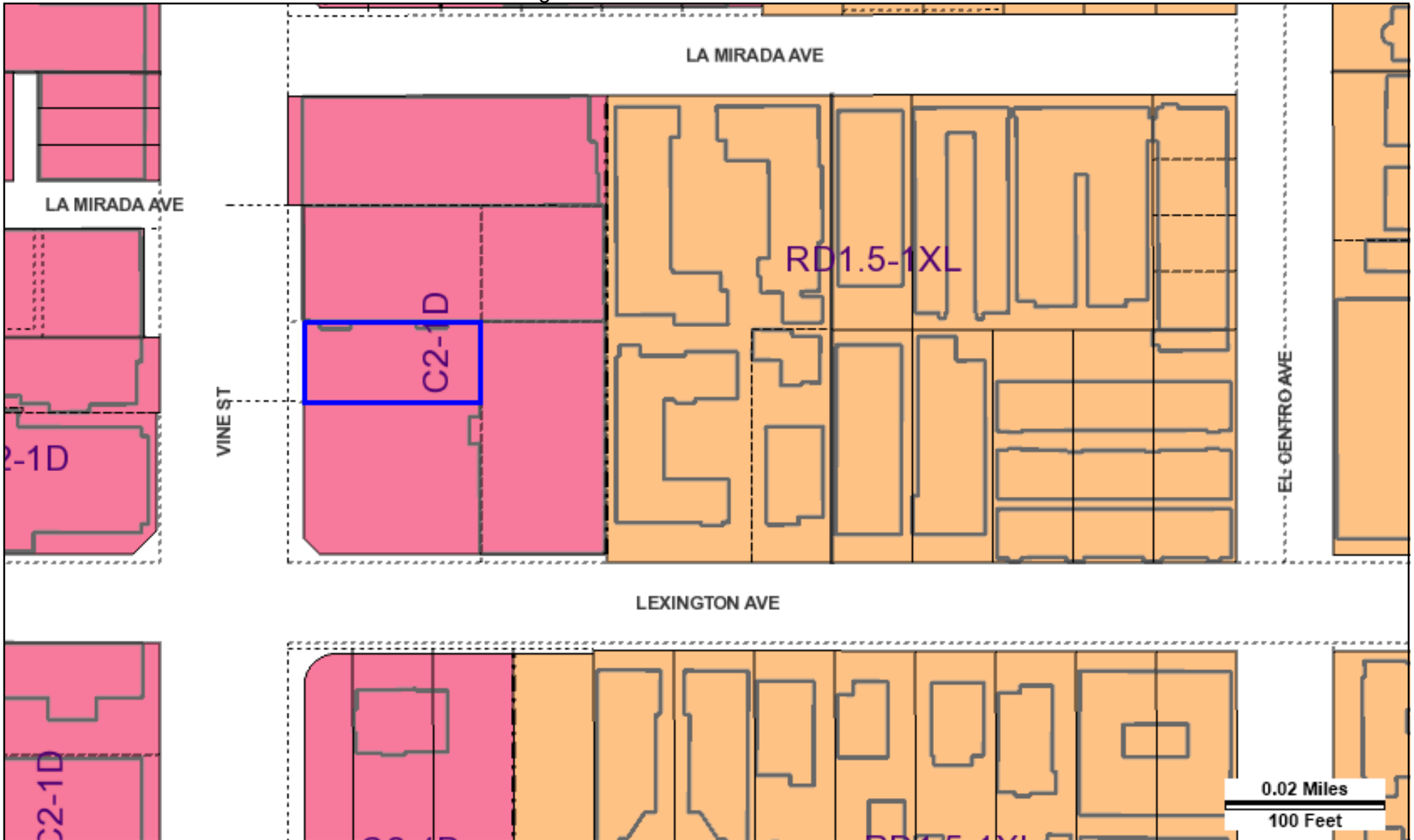

Address: undefined
 APN: 5534002023
 PIN #: 144B189 322

Tract: COLEGROVE
 Block: BLK 12
 Lot: FR
 Arb: 5

Zoning: C2-1D
 General Plan: Highway Oriented Commercial





City of Los Angeles Department of City Planning

9/26/2022 PARCEL PROFILE REPORT

PROPERTY ADDRESSES

1204 N VINE ST
1200 N VINE ST

ZIP CODES

90038

RECENT ACTIVITY

None

CASE NUMBERS

CPC-2016-1450-CPU
CPC-2014-669-CPU
CPC-2005-6082
CPC-1997-43-CPU
CPC-1986-831-GPC
CPC-1984-1-HD
ORD-98865
ORD-182960
ORD-182173-SA19
ORD-164692
ORD-161116-SA19
ZA-19XX-8370
ZA-14237
ZA-11663
ENV-2016-1451-EIR
ENV-2014-670-SE
ENV-2005-2158-EIR
AFF-44439-A
AFF-28153

Address/Legal Information

PIN Number	144B189 338
Lot/Parcel Area (Calculated)	10,417.6 (sq ft)
Thomas Brothers Grid	PAGE 593 - GRID F5
Assessor Parcel No. (APN)	5534002023
Tract	COLEGROVE
Map Reference	M R 53-10
Block	BLK 12
Lot	FR
Arb (Lot Cut Reference)	4
Map Sheet	144B189

Jurisdictional Information

Community Plan Area	Hollywood
Area Planning Commission	Central
Neighborhood Council	Central Hollywood
Council District	CD 13 - Mitch O'Farrell
Census Tract #	1908.01
LADBS District Office	Los Angeles Metro

Permitting and Zoning Compliance Information

Administrative Review	None
-----------------------	------

Planning and Zoning Information

Special Notes	None
Zoning	C2-1D
Zoning Information (ZI)	ZI-2374 State Enterprise Zone: Los Angeles ZI-2498 Local Emergency Temporary Regulations - Time Limits and Parking Relief - LAMC 16.02.1 ZI-2433 Revised Hollywood Community Plan Injunction ZI-2452 Transit Priority Area in the City of Los Angeles
General Plan Land Use	Highway Oriented Commercial
General Plan Note(s)	Yes
Hillside Area (Zoning Code)	No
Specific Plan Area	None
Subarea	None
Special Land Use / Zoning	None
Historic Preservation Review	No
Historic Preservation Overlay Zone	None
Other Historic Designations	None
Other Historic Survey Information	None
Mills Act Contract	None
CDO: Community Design Overlay	None
CPIO: Community Plan Imp. Overlay	None
Subarea	None
CUGU: Clean Up-Green Up	None
HCR: Hillside Construction Regulation	No
NSO: Neighborhood Stabilization Overlay	No
POD: Pedestrian Oriented Districts	None
RBP: Restaurant Beverage Program Eligible Area	General (RBPA)

This report is subject to the terms and conditions as set forth on the website. For more details, please refer to the terms and conditions at zimas.lacity.org
(*) - APN Area is provided "as is" from the Los Angeles County's Public Works, Flood Control, Benefit Assessment.

RFA: Residential Floor Area District	None
RIO: River Implementation Overlay	No
SN: Sign District	No
Streetscape	No
Adaptive Reuse Incentive Area	None
Affordable Housing Linkage Fee	
Residential Market Area	Medium-High
Non-Residential Market Area	High
Transit Oriented Communities (TOC)	Tier 1
RPA: Redevelopment Project Area	None
Central City Parking	No
Downtown Parking	No
Building Line	None
500 Ft School Zone	No
500 Ft Park Zone	No

Assessor Information

Assessor Parcel No. (APN)	5534002023
APN Area (Co. Public Works)*	0.623 (ac)
Use Code	1100 - Commercial - Store - One Story
Assessed Land Val.	\$764,661
Assessed Improvement Val.	\$0
Last Owner Change	12/30/2021
Last Sale Amount	\$17,000,170
Tax Rate Area	67
Deed Ref No. (City Clerk)	774614
	5-887
	240867-8
	1697229
	1667998
	1369937
	1136078
	1130390

Building 1

Year Built	1992
Building Class	C6A
Number of Units	1
Number of Bedrooms	0
Number of Bathrooms	0
Building Square Footage	13,475.0 (sq ft)

Building 2 No data for building 2

Building 3 No data for building 3

Building 4 No data for building 4

Building 5 No data for building 5

Rent Stabilization Ordinance (RSO) No [APN: 5534002023]

Additional Information

Airport Hazard	None
Coastal Zone	None
Farmland	Area Not Mapped
Urban Agriculture Incentive Zone	YES
Very High Fire Hazard Severity Zone	No
Fire District No. 1	No
Flood Zone	Outside Flood Zone
Watercourse	No
Hazardous Waste / Border Zone Properties	No
Methane Hazard Site	None

This report is subject to the terms and conditions as set forth on the website. For more details, please refer to the terms and conditions at zimas.lacity.org
 (*) - APN Area is provided "as is" from the Los Angeles County's Public Works, Flood Control, Benefit Assessment.

High Wind Velocity Areas	No
Special Grading Area (BOE Basic Grid Map A-13372)	No
Wells	None

Seismic Hazards

Active Fault Near-Source Zone	
Nearest Fault (Distance in km)	1.67880792
Nearest Fault (Name)	Hollywood Fault
Region	Transverse Ranges and Los Angeles Basin
Fault Type	B
Slip Rate (mm/year)	1.00000000
Slip Geometry	Left Lateral - Reverse - Oblique
Slip Type	Poorly Constrained
Down Dip Width (km)	14.00000000
Rupture Top	0.00000000
Rupture Bottom	13.00000000
Dip Angle (degrees)	70.00000000
Maximum Magnitude	6.40000000
Alquist-Priolo Fault Zone	No
Landslide	No
Liquefaction	No
Preliminary Fault Rupture Study Area	No
Tsunami Inundation Zone	No

Economic Development Areas

Business Improvement District	HOLLYWOOD ENTERTAINMENT DISTRICT
Hubzone	Qualified
Jobs and Economic Development Incentive Zone (JEDI)	None
Opportunity Zone	Yes
Promise Zone	Los Angeles
State Enterprise Zone	LOS ANGELES STATE ENTERPRISE ZONE

Housing

Direct all Inquiries to	Los Angeles Housing Department
Telephone	(866) 557-7368
Website	https://housing.lacity.org
Rent Stabilization Ordinance (RSO)	No [APN: 5534002023]
Ellis Act Property	No
AB 1482: Tenant Protection Act	No
Housing Crisis Act Replacement Review	Yes

Public Safety

Police Information	
Bureau	West
Division / Station	Hollywood
Reporting District	666
Fire Information	
Bureau	West
Battalion	5
District / Fire Station	27
Red Flag Restricted Parking	No

CASE SUMMARIES

Note: Information for case summaries is retrieved from the Planning Department's Plan Case Tracking System (PCTS) database.

Case Number:	CPC-2016-1450-CPU
Required Action(s):	CPU-COMMUNITY PLAN UPDATE
Project Descriptions(s):	UPDATE TO THE HOLLYWOOD COMMUNITY PLAN
Case Number:	CPC-2014-669-CPU
Required Action(s):	CPU-COMMUNITY PLAN UPDATE
Project Descriptions(s):	COMMUNITY PLAN UPDATE/GENERAL PLAN AMENDMENT
Case Number:	CPC-2005-6082
Required Action(s):	Data Not Available
Project Descriptions(s):	HOLLYWOOD COMMUNITY PLAN UPDATE
Case Number:	CPC-1997-43-CPU
Required Action(s):	CPU-COMMUNITY PLAN UPDATE
Project Descriptions(s):	COMMUNITY PLAN UPDATE FOR HOLLYWOOD WHICH IDENTIFIES AND REDEFINES OUTDATED LAND USE ISSUES AND INCONSISTENT ZONING, REVIEWS POLICIES AND PROGRAMS, AS WELL AS REVISING AND UPDATING THE PLAN MAP AND TEXT
Case Number:	CPC-1986-831-GPC
Required Action(s):	GPC-GENERAL PLAN/ZONING CONSISTENCY (AB283)
Project Descriptions(s):	HOLLYWOOD COMMUNITY PLAN REVISION/GENERAL PLAN CONSISTENCY PLAN AMENDMENT, ZONE CHANGES AND HEIGHT DISTRICT CHANGES
Case Number:	CPC-1984-1-HD
Required Action(s):	HD-HEIGHT DISTRICT
Project Descriptions(s):	CHANGE OF HEIGHT DISTRICT WITHIN THE "CORE AREA OF L.A."- GENERAL PLAN ZONE CONSISTENCY PROGRAM.
Case Number:	ZA-19XX-8370
Required Action(s):	Data Not Available
Project Descriptions(s):	
Case Number:	ENV-2016-1451-EIR
Required Action(s):	EIR-ENVIRONMENTAL IMPACT REPORT
Project Descriptions(s):	UPDATE TO THE HOLLYWOOD COMMUNITY PLAN
Case Number:	ENV-2014-670-SE
Required Action(s):	SE-STATUTORY EXEMPTIONS
Project Descriptions(s):	COMMUNITY PLAN UPDATE/GENERAL PLAN AMENDMENT
Case Number:	ENV-2005-2158-EIR
Required Action(s):	EIR-ENVIRONMENTAL IMPACT REPORT
Project Descriptions(s):	COMMUNITY PLAN UPDATE FOR HOLLYWOOD WHICH IDENTIFIES AND REDEFINES OUTDATED LAND USE ISSUES AND INCONSISTENT ZONING, REVIEWS POLICIES AND PROGRAMS, AS WELL AS REVISING AND UPDATING THE PLAN MAP AND TEXT
Case Number:	AFF-44439-A
Required Action(s):	A-PRIVATE STREET MODIFICATIONS (1ST REQUEST)
Project Descriptions(s):	Data Not Available

DATA NOT AVAILABLE

ORD-98865
ORD-182960
ORD-182173-SA19
ORD-164692
ORD-161116-SA19
ZA-14237
ZA-11663
AFF-28153

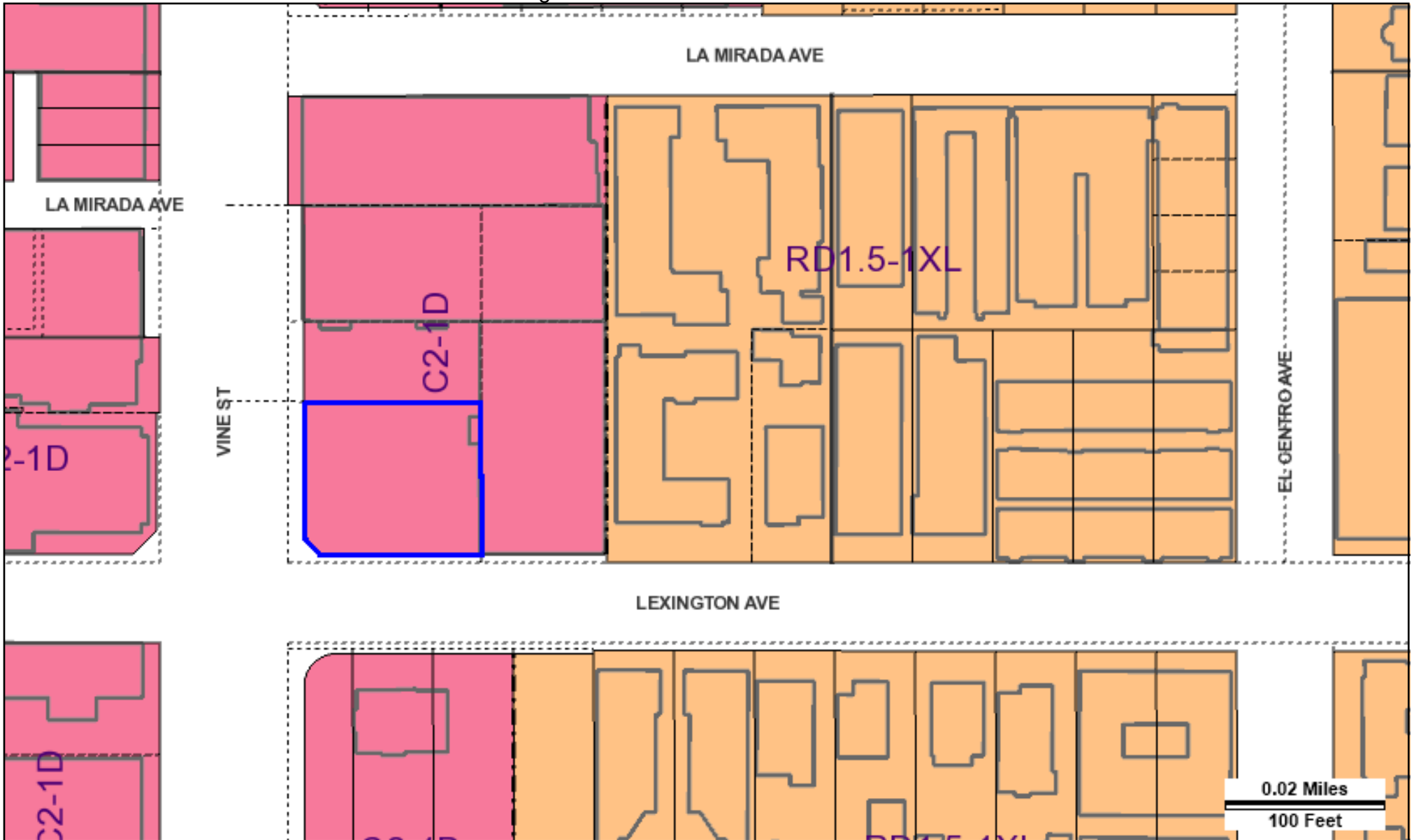

Address: 1204 N VINE ST
 APN: 5534002023
 PIN #: 144B189 338

Tract: COLEGROVE
 Block: BLK 12
 Lot: FR
 Arb: 4

Zoning: C2-1D
 General Plan: Highway Oriented Commercial





City of Los Angeles Department of City Planning

9/26/2022 PARCEL PROFILE REPORT

PROPERTY ADDRESSES

6245 W LEXINGTON AVE
6247 W LEXINGTON AVE

ZIP CODES

90038

RECENT ACTIVITY

None

CASE NUMBERS

CPC-2016-1450-CPU
CPC-2014-669-CPU
CPC-2005-6082
CPC-1997-43-CPU
CPC-1986-831-GPC
CPC-1984-1-HD
ORD-182960
ORD-182173-SA19
ORD-164692
ORD-161116-SA19
ZA-19XX-8370
ZA-14237
ZA-11663
ENV-2016-1451-EIR
ENV-2014-670-SE
ENV-2005-2158-EIR
AFF-44439-A
AFF-28153

Address/Legal Information

PIN Number	144B189 321
Lot/Parcel Area (Calculated)	11,309.9 (sq ft)
Thomas Brothers Grid	PAGE 593 - GRID F5
Assessor Parcel No. (APN)	5534002023
Tract	COLEGROVE
Map Reference	M R 53-10
Block	BLK 12
Lot	FR
Arb (Lot Cut Reference)	3
Map Sheet	144B189

Jurisdictional Information

Community Plan Area	Hollywood
Area Planning Commission	Central
Neighborhood Council	Central Hollywood
Council District	CD 13 - Mitch O'Farrell
Census Tract #	1908.01
LADBS District Office	Los Angeles Metro

Permitting and Zoning Compliance Information

Administrative Review	None
-----------------------	------

Planning and Zoning Information

Special Notes	None
Zoning	C2-1D
Zoning Information (ZI)	ZI-2374 State Enterprise Zone: Los Angeles ZI-2498 Local Emergency Temporary Regulations - Time Limits and Parking Relief - LAMC 16.02.1 ZI-2433 Revised Hollywood Community Plan Injunction ZI-2452 Transit Priority Area in the City of Los Angeles
General Plan Land Use	Highway Oriented Commercial
General Plan Note(s)	Yes
Hillside Area (Zoning Code)	No
Specific Plan Area	None
Subarea	None
Special Land Use / Zoning	None
Historic Preservation Review	No
Historic Preservation Overlay Zone	None
Other Historic Designations	None
Other Historic Survey Information	None
Mills Act Contract	None
CDO: Community Design Overlay	None
CPIO: Community Plan Imp. Overlay	None
Subarea	None
CUGU: Clean Up-Green Up	None
HCR: Hillside Construction Regulation	No
NSO: Neighborhood Stabilization Overlay	No
POD: Pedestrian Oriented Districts	None
RBP: Restaurant Beverage Program Eligible Area	General (RBPA)

This report is subject to the terms and conditions as set forth on the website. For more details, please refer to the terms and conditions at zimas.lacity.org
(*) - APN Area is provided "as is" from the Los Angeles County's Public Works, Flood Control, Benefit Assessment.

RFA: Residential Floor Area District	None
RIO: River Implementation Overlay	No
SN: Sign District	No
Streetscape	No
Adaptive Reuse Incentive Area	None
Affordable Housing Linkage Fee	
Residential Market Area	Medium-High
Non-Residential Market Area	High
Transit Oriented Communities (TOC)	Tier 1
RPA: Redevelopment Project Area	None
Central City Parking	No
Downtown Parking	No
Building Line	None
500 Ft School Zone	No
500 Ft Park Zone	No

Assessor Information

Assessor Parcel No. (APN)	5534002023
APN Area (Co. Public Works)*	0.623 (ac)
Use Code	1100 - Commercial - Store - One Story
Assessed Land Val.	\$764,661
Assessed Improvement Val.	\$0
Last Owner Change	12/30/2021
Last Sale Amount	\$17,000,170
Tax Rate Area	67
Deed Ref No. (City Clerk)	774614
	5-887
	240867-8
	1697229
	1667998
	1369937
	1136078
	1130390

Building 1

Year Built	1992
Building Class	C6A
Number of Units	1
Number of Bedrooms	0
Number of Bathrooms	0
Building Square Footage	13,475.0 (sq ft)

Building 2 No data for building 2

Building 3 No data for building 3

Building 4 No data for building 4

Building 5 No data for building 5

Rent Stabilization Ordinance (RSO) No [APN: 5534002023]

Additional Information

Airport Hazard	None
Coastal Zone	None
Farmland	Area Not Mapped
Urban Agriculture Incentive Zone	YES
Very High Fire Hazard Severity Zone	No
Fire District No. 1	No
Flood Zone	Outside Flood Zone
Watercourse	No
Hazardous Waste / Border Zone Properties	No
Methane Hazard Site	None

This report is subject to the terms and conditions as set forth on the website. For more details, please refer to the terms and conditions at zimas.lacity.org
 (*) - APN Area is provided "as is" from the Los Angeles County's Public Works, Flood Control, Benefit Assessment.

High Wind Velocity Areas	No
Special Grading Area (BOE Basic Grid Map A-13372)	No
Wells	None

Seismic Hazards

Active Fault Near-Source Zone	
Nearest Fault (Distance in km)	1.67194992
Nearest Fault (Name)	Hollywood Fault
Region	Transverse Ranges and Los Angeles Basin
Fault Type	B
Slip Rate (mm/year)	1.00000000
Slip Geometry	Left Lateral - Reverse - Oblique
Slip Type	Poorly Constrained
Down Dip Width (km)	14.00000000
Rupture Top	0.00000000
Rupture Bottom	13.00000000
Dip Angle (degrees)	70.00000000
Maximum Magnitude	6.40000000
Alquist-Priolo Fault Zone	No
Landslide	No
Liquefaction	No
Preliminary Fault Rupture Study Area	No
Tsunami Inundation Zone	No

Economic Development Areas

Business Improvement District	HOLLYWOOD ENTERTAINMENT DISTRICT
Hubzone	Qualified
Jobs and Economic Development Incentive Zone (JEDI)	None
Opportunity Zone	Yes
Promise Zone	Los Angeles
State Enterprise Zone	LOS ANGELES STATE ENTERPRISE ZONE

Housing

Direct all Inquiries to	Los Angeles Housing Department
Telephone	(866) 557-7368
Website	https://housing.lacity.org
Rent Stabilization Ordinance (RSO)	No [APN: 5534002023]
Ellis Act Property	No
AB 1482: Tenant Protection Act	No
Housing Crisis Act Replacement Review	Yes

Public Safety

Police Information	
Bureau	West
Division / Station	Hollywood
Reporting District	666
Fire Information	
Bureau	West
Battalion	5
District / Fire Station	27
Red Flag Restricted Parking	No

CASE SUMMARIES

Note: Information for case summaries is retrieved from the Planning Department's Plan Case Tracking System (PCTS) database.

Case Number:	CPC-2016-1450-CPU
Required Action(s):	CPU-COMMUNITY PLAN UPDATE
Project Descriptions(s):	UPDATE TO THE HOLLYWOOD COMMUNITY PLAN
Case Number:	CPC-2014-669-CPU
Required Action(s):	CPU-COMMUNITY PLAN UPDATE
Project Descriptions(s):	COMMUNITY PLAN UPDATE/GENERAL PLAN AMENDMENT
Case Number:	CPC-2005-6082
Required Action(s):	Data Not Available
Project Descriptions(s):	HOLLYWOOD COMMUNITY PLAN UPDATE
Case Number:	CPC-1997-43-CPU
Required Action(s):	CPU-COMMUNITY PLAN UPDATE
Project Descriptions(s):	COMMUNITY PLAN UPDATE FOR HOLLYWOOD WHICH IDENTIFIES AND REDEFINES OUTDATED LAND USE ISSUES AND INCONSISTENT ZONING, REVIEWS POLICIES AND PROGRAMS, AS WELL AS REVISING AND UPDATING THE PLAN MAP AND TEXT
Case Number:	CPC-1986-831-GPC
Required Action(s):	GPC-GENERAL PLAN/ZONING CONSISTENCY (AB283)
Project Descriptions(s):	HOLLYWOOD COMMUNITY PLAN REVISION/GENERAL PLAN CONSISTENCY PLAN AMENDMENT, ZONE CHANGES AND HEIGHT DISTRICT CHANGES
Case Number:	CPC-1984-1-HD
Required Action(s):	HD-HEIGHT DISTRICT
Project Descriptions(s):	CHANGE OF HEIGHT DISTRICT WITHIN THE "CORE AREA OF L.A."- GENERAL PLAN ZONE CONSISTENCY PROGRAM.
Case Number:	ZA-19XX-8370
Required Action(s):	Data Not Available
Project Descriptions(s):	
Case Number:	ENV-2016-1451-EIR
Required Action(s):	EIR-ENVIRONMENTAL IMPACT REPORT
Project Descriptions(s):	UPDATE TO THE HOLLYWOOD COMMUNITY PLAN
Case Number:	ENV-2014-670-SE
Required Action(s):	SE-STATUTORY EXEMPTIONS
Project Descriptions(s):	COMMUNITY PLAN UPDATE/GENERAL PLAN AMENDMENT
Case Number:	ENV-2005-2158-EIR
Required Action(s):	EIR-ENVIRONMENTAL IMPACT REPORT
Project Descriptions(s):	COMMUNITY PLAN UPDATE FOR HOLLYWOOD WHICH IDENTIFIES AND REDEFINES OUTDATED LAND USE ISSUES AND INCONSISTENT ZONING, REVIEWS POLICIES AND PROGRAMS, AS WELL AS REVISING AND UPDATING THE PLAN MAP AND TEXT
Case Number:	AFF-44439-A
Required Action(s):	A-PRIVATE STREET MODIFICATIONS (1ST REQUEST)
Project Descriptions(s):	Data Not Available

DATA NOT AVAILABLE

ORD-182960
ORD-182173-SA19
ORD-164692
ORD-161116-SA19
ZA-14237
ZA-11663
AFF-28153

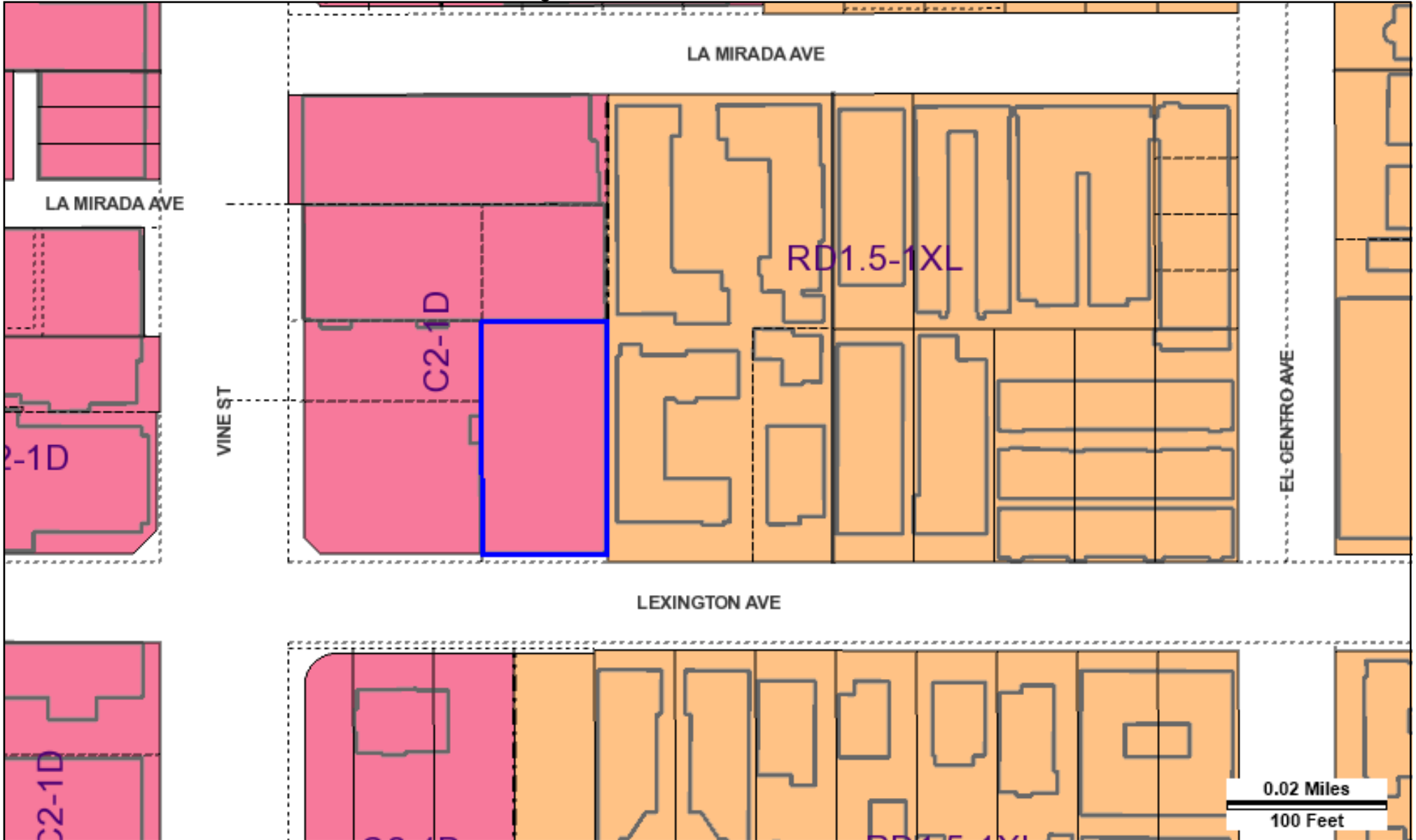

Address: 6245 W LEXINGTON AVE

APN: 5534002023

PIN #: 144B189 321

Tract: COLEGROVE

Block: BLK 12

Lot: FR

Arb: 3

Zoning: C2-1D

General Plan: Highway Oriented Commercial



0.02 Miles

100 Feet



Exhibit D – Site & Surrounding Area

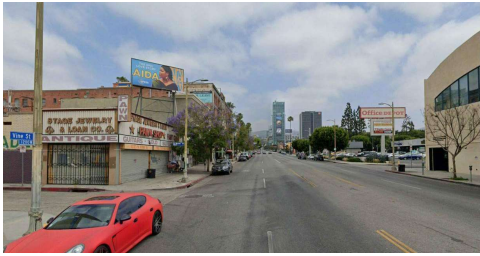

[1]



[5]



[7]



[2]

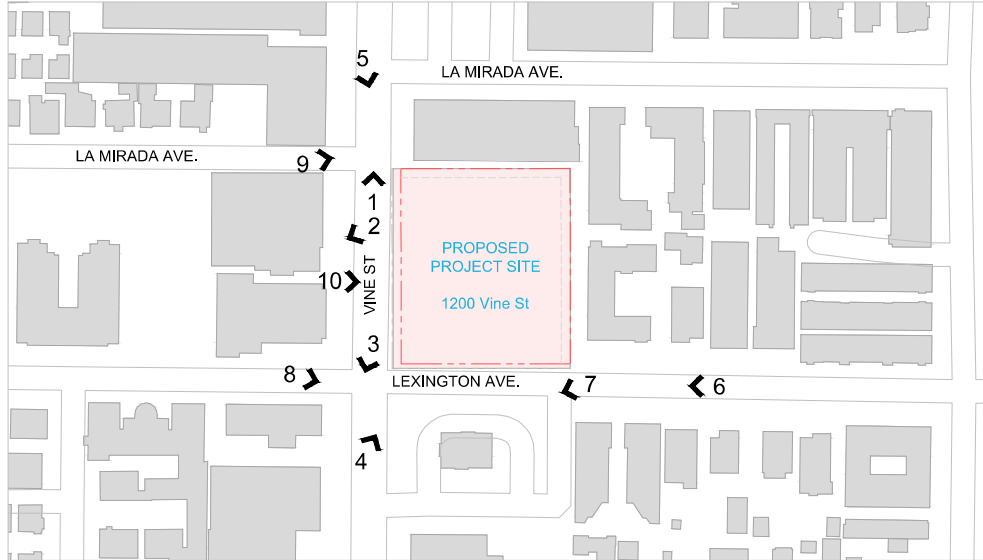

[8]



[3]



[9]

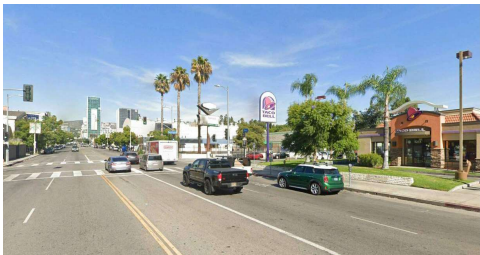

[4]



[6]



[10]



Architecture + Planning
888.456.5849
ktgy.com

Grubb Properties
4601 Park Road, Suite 450
Charlotte, NC 28209

1200 VINE STREET
LOS ANGELES, CA # 2021-1034

CONCEPTUAL DESIGN
SEPTEMBER 16, 2022



EXISTING CONTEXT

A0-2

Exhibit E – Public Correspondence

P: (626) 381-9248
F: (626) 389-5414
E: info@mitschtsailaw.com



Mitchell M. Tsai
Attorney At Law

139 South Hudson Avenue
Suite 200
Pasadena, California 91101

VIA E-MAIL

February 7, 2023

Stephanie Escobar, Planning Assistant
City of Los Angeles City Planning Commission
200 North Spring Street, Rm 763
Los Angeles, CA 90012
Em: Stephanie.Escobar@lacity.org

RE: City of Los Angeles' 1200 North Vine Street Project (CPC-2022-7047-CU-DB-SPR-HCA) (ENV-2022-7048-CE).

Dear Stephanie Escobar,

On behalf of the Southwest Mountain States Regional Council of Carpenters (“**Southwest Carpenters**” or “**SWMSRCC**”), my Office is submitting these comments for the City of Los Angeles’ (“**City**”) February 7, 2023, Hearing Officer Hearing on behalf of City Planning Commission for the City of Los Angeles’ 1200 North Vine Street Project (CPC-2022-7047-CU-DB-SPR-HCA) (ENV-2022-7048-CE) (“**Project**”).

The Southwest Carpenters is a labor union representing over 63,000 union carpenters in 10 states, including California, and has a strong interest in well-ordered land use planning and in addressing the environmental impacts of development projects.

Individual members of the Southwest Carpenters live, work, and recreate in the City and surrounding communities and would be directly affected by the Project’s environmental impacts.

The Southwest Carpenters expressly reserves the right to supplement these comments at or prior to hearings on the Project, and at any later hearing and proceeding related to this Project. Gov. Code, § 65009, subd. (b); Pub. Res. Code, § 21177, subd. (a); see *Bakersfield Citizens for Local Control v. Bakersfield* (2004) 124 Cal.App.4th 1184, 1199-1203; see also *Galante Vineyards v. Monterey Water Dist.* (1997) 60 Cal.App.4th 1109, 1121.

The Southwest Carpenters incorporates by reference all comments raising issues regarding the Environmental Impact Report (EIR) submitted prior to certification of the EIR for the Project. See *Citizens for Clean Energy v City of Woodland* (2014) 225 Cal.App.4th 173, 191 (finding that any party who has objected to the project’s environmental documentation may assert any issue timely raised by other parties).

Moreover, the Southwest Carpenters requests that the City provide notice for any and all notices referring or related to the Project issued under the California Environmental Quality Act (**CEQA**) (Pub. Res. Code, § 21000 *et seq.*), and the California Planning and Zoning Law (“**Planning and Zoning Law**”) (Gov. Code, §§ 65000–65010). California Public Resources Code Sections 21092.2, and 21167(f) and California Government Code Section 65092 require agencies to mail such notices to any person who has filed a written request for them with the clerk of the agency’s governing body.

I. THE CITY SHOULD REQUIRE THE USE OF A LOCAL WORKFORCE TO BENEFIT THE COMMUNITY’S ECONOMIC DEVELOPMENT AND ENVIRONMENT

The City should require the Project to be built using local workers who have graduated from a Joint Labor-Management Apprenticeship Program approved by the State of California, have at least as many hours of on-the-job experience in the applicable craft which would be required to graduate from such a state-approved apprenticeship training program, or who are registered apprentices in a state-approved apprenticeship training program.

Community benefits such as local hire can also be helpful to reduce environmental impacts and improve the positive economic impact of the Project. Local hire provisions requiring that a certain percentage of workers reside within 10 miles or less of the Project site can reduce the length of vendor trips, reduce greenhouse gas emissions, and provide localized economic benefits. As environmental consultants Matt Hagemann and Paul E. Rosenfeld note:

[A]ny local hire requirement that results in a decreased worker trip length from the default value has the potential to result in a reduction of construction-related GHG emissions, though the significance of the reduction would vary based on the location and urbanization level of the project site.

March 8, 2021, SWAPE Letter to Mitchell M. Tsai re Local Hire Requirements and Considerations for Greenhouse Gas Modeling.

Workforce requirements promote the development of skilled trades that yield sustainable economic development. As the California Workforce Development Board and the University of California, Berkeley Center for Labor Research and Education concluded:

[L]abor should be considered an investment rather than a cost—and investments in growing, diversifying, and upskilling California’s workforce can positively affect returns on climate mitigation efforts. In other words, well-trained workers are key to delivering emissions reductions and moving California closer to its climate targets.¹

Furthermore, workforce policies have significant environmental benefits given that they improve an area’s jobs-housing balance, decreasing the amount and length of job commutes and the associated greenhouse gas (GHG) emissions. In fact, on May 7, 2021, the South Coast Air Quality Management District found that that the “[u]se of a local state-certified apprenticeship program” can result in air pollutant reductions.²

Locating jobs closer to residential areas can have significant environmental benefits. As the California Planning Roundtable noted in 2008:

People who live and work in the same jurisdiction would be more likely to take transit, walk, or bicycle to work than residents of less balanced communities and their vehicle trips would be shorter. Benefits would include potential reductions in both vehicle miles traveled and vehicle hours traveled.³

¹ California Workforce Development Board (2020) Putting California on the High Road: A Jobs and Climate Action Plan for 2030 at p. ii, *available at* <https://laborcenter.berkeley.edu/wp-content/uploads/2020/09/Putting-California-on-the-High-Road.pdf>.

² South Coast Air Quality Management District (May 7, 2021) Certify Final Environmental Assessment and Adopt Proposed Rule 2305 – Warehouse Indirect Source Rule – Warehouse Actions and Investments to Reduce Emissions Program, and Proposed Rule 316 – Fees for Rule 2305, Submit Rule 2305 for Inclusion Into the SIP, and Approve Supporting Budget Actions, *available at* <http://www.aqmd.gov/docs/default-source/Agendas/Governing-Board/2021/2021-May7-027.pdf?sfvrsn=10>.

³ California Planning Roundtable (2008) Deconstructing Jobs-Housing Balance at p. 6, *available at* <https://cproundtable.org/static/media/uploads/publications/cpr-jobs-housing.pdf>

Moreover, local hire mandates and skill-training are critical facets of a strategy to reduce vehicle miles traveled (VMT). As planning experts Robert Cervero and Michael Duncan have noted, simply placing jobs near housing stock is insufficient to achieve VMT reductions given that the skill requirements of available local jobs must match those held by local residents.⁴ Some municipalities have even tied local hire and other workforce policies to local development permits to address transportation issues. Cervero and Duncan note that:

In nearly built-out Berkeley, CA, the approach to balancing jobs and housing is to create local jobs rather than to develop new housing. The city's First Source program encourages businesses to hire local residents, especially for entry- and intermediate-level jobs, and sponsors vocational training to ensure residents are employment-ready. While the program is voluntary, some 300 businesses have used it to date, placing more than 3,000 city residents in local jobs since it was launched in 1986. When needed, these carrots are matched by sticks, since the city is not shy about negotiating corporate participation in First Source as a condition of approval for development permits.

Recently, the State of California verified its commitment towards workforce development through the Affordable Housing and High Road Jobs Act of 2022, otherwise known as Assembly Bill No. 2011 (“**AB2011**”). AB2011 amended the Planning and Zoning Law to allow ministerial, by-right approval for projects being built alongside commercial corridors that meet affordability and labor requirements.

The City should consider utilizing local workforce policies and requirements to benefit the local area economically and to mitigate greenhouse gas, improve air quality, and reduce transportation impacts.

II. THE CITY SHOULD IMPOSE TRAINING REQUIREMENTS FOR THE PROJECT'S CONSTRUCTION ACTIVITIES TO PREVENT COMMUNITY SPREAD OF COVID-19 AND OTHER INFECTIOUS DISEASES

⁴ Cervero, Robert and Duncan, Michael (2006) Which Reduces Vehicle Travel More: Jobs-Housing Balance or Retail-Housing Mixing? *Journal of the American Planning Association* 72 (4), 475-490, 482, available at <http://reconnectingamerica.org/assets/Uploads/UTCT-825.pdf>.

Construction work has been defined as a Lower to High-risk activity for COVID-19 spread by the Occupational Safety and Health Administration. Recently, several construction sites have been identified as sources of community spread of COVID-19.⁵

Southwest Carpenters recommend that the Lead Agency adopt additional requirements to mitigate public health risks from the Project's construction activities. Southwest Carpenters requests that the Lead Agency require safe on-site construction work practices as well as training and certification for any construction workers on the Project Site.

In particular, based upon Southwest Carpenters' experience with safe construction site work practices, Southwest Carpenters recommends that the Lead Agency require that while construction activities are being conducted at the Project Site:

Construction Site Design:

- The Project Site will be limited to two controlled entry points.
- Entry points will have temperature screening technicians taking temperature readings when the entry point is open.
- The Temperature Screening Site Plan shows details regarding access to the Project Site and Project Site logistics for conducting temperature screening.
- A 48-hour advance notice will be provided to all trades prior to the first day of temperature screening.
- The perimeter fence directly adjacent to the entry points will be clearly marked indicating the appropriate 6-foot social distancing position for when you approach the screening area. Please reference the Apex temperature screening site map for additional details.

⁵ Santa Clara County Public Health (June 12, 2020) COVID-19 CASES AT CONSTRUCTION SITES HIGHLIGHT NEED FOR CONTINUED VIGILANCE IN SECTORS THAT HAVE REOPENED, available at <https://www.sccgov.org/sites/covid19/Pages/press-release-06-12-2020-cases-at-construction-sites.aspx>.

- There will be clear signage posted at the project site directing you through temperature screening.
- Provide hand washing stations throughout the construction site.

Testing Procedures:

- The temperature screening being used are non-contact devices.
- Temperature readings will not be recorded.
- Personnel will be screened upon entering the testing center and should only take 1-2 seconds per individual.
- Hard hats, head coverings, sweat, dirt, sunscreen or any other cosmetics must be removed on the forehead before temperature screening.
- Anyone who refuses to submit to a temperature screening or does not answer the health screening questions will be refused access to the Project Site.
- Screening will be performed at both entrances from 5:30 am to 7:30 am.; main gate [ZONE 1] and personnel gate [ZONE 2]
- After 7:30 am only the main gate entrance [ZONE 1] will continue to be used for temperature testing for anybody gaining entry to the project site such as returning personnel, deliveries, and visitors.
- If the digital thermometer displays a temperature reading above 100.0 degrees Fahrenheit, a second reading will be taken to verify an accurate reading.
- If the second reading confirms an elevated temperature, DHS will instruct the individual that he/she will not be allowed to enter the Project Site. DHS will also instruct the individual to promptly notify his/her supervisor and his/her

human resources (HR) representative and provide them with a copy of Annex A.

Planning

- Require the development of an Infectious Disease Preparedness and Response Plan that will include basic infection prevention measures (requiring the use of personal protection equipment), policies and procedures for prompt identification and isolation of sick individuals, social distancing (prohibiting gatherings of no more than 10 people including all-hands meetings and all-hands lunches) communication and training and workplace controls that meet standards that may be promulgated by the Center for Disease Control, Occupational Safety and Health Administration, Cal/OSHA, California Department of Public Health or applicable local public health agencies.⁶

The United Brotherhood of Carpenters and Carpenters International Training Fund has developed COVID-19 Training and Certification to ensure that Carpenter union members and apprentices conduct safe work practices. The Agency should require that all construction workers undergo COVID-19 Training and Certification before being allowed to conduct construction activities at the Project Site.

Southwest Carpenters has also developed a rigorous Infection Control Risk Assessment (“**ICRA**”) training program to ensure it delivers a workforce that understands how to identify and control infection risks by implementing protocols to protect themselves and all others during renovation and construction projects in healthcare environments.⁷

⁶ See also The Center for Construction Research and Training, North America’s Building Trades Unions (April 27 2020) NABTU and CPWR COVID-19 Standards for U.S. Construction Sites, available at https://www.cpwr.com/sites/default/files/NABTU_CPWR_Standards_COVID-19.pdf; Los Angeles County Department of Public Works (2020) Guidelines for Construction Sites During COVID-19 Pandemic, available at https://dpw.lacounty.gov/building-and-safety/docs/pw_guidelines-construction-sites.pdf.

⁷ For details concerning Southwest Carpenters’s ICRA training program, see <https://icrahealthcare.com/>.

ICRA protocols are intended to contain pathogens, control airflow, and protect patients during the construction, maintenance and renovation of healthcare facilities. ICRA protocols prevent cross contamination, minimizing the risk of secondary infections in patients at hospital facilities.

The City should require the Project to be built using a workforce trained in ICRA protocols.

Sincerely,

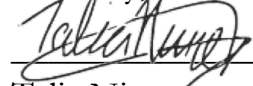

Talia Nimmer

Attorneys for Southwest Regional
Council of Carpenters

Attached:

March 8, 2021, SWAPE Letter to Mitchell M. Tsai re Local Hire Requirements and Considerations for Greenhouse Gas Modeling (Exhibit A);

Air Quality and GHG Expert Paul Rosenfeld CV (Exhibit B); and

Air Quality and GHG Expert Matt Hagemann CV (Exhibit C).

EXHIBIT A



Technical Consultation, Data Analysis and
Litigation Support for the Environment

2656 29th Street, Suite 201
Santa Monica, CA 90405

Matt Hagemann, P.G, C.Hg.
(949) 887-9013
mhagemann@swape.com

Paul E. Rosenfeld, PhD
(310) 795-2335
prosenfeld@swape.com

March 8, 2021

Mitchell M. Tsai
155 South El Molino, Suite 104
Pasadena, CA 91101

Subject: Local Hire Requirements and Considerations for Greenhouse Gas Modeling

Dear Mr. Tsai,

Soil Water Air Protection Enterprise (“SWAPE”) is pleased to provide the following draft technical report explaining the significance of worker trips required for construction of land use development projects with respect to the estimation of greenhouse gas (“GHG”) emissions. The report will also discuss the potential for local hire requirements to reduce the length of worker trips, and consequently, reduced or mitigate the potential GHG impacts.

Worker Trips and Greenhouse Gas Calculations

The California Emissions Estimator Model (“CalEEMod”) is a “statewide land use emissions computer model designed to provide a uniform platform for government agencies, land use planners, and environmental professionals to quantify potential criteria pollutant and greenhouse gas (GHG) emissions associated with both construction and operations from a variety of land use projects.”¹ CalEEMod quantifies construction-related emissions associated with land use projects resulting from off-road construction equipment; on-road mobile equipment associated with workers, vendors, and hauling; fugitive dust associated with grading, demolition, truck loading, and on-road vehicles traveling along paved and unpaved roads; and architectural coating activities; and paving.²

The number, length, and vehicle class of worker trips are utilized by CalEEMod to calculate emissions associated with the on-road vehicle trips required to transport workers to and from the Project site during construction.³

¹ “California Emissions Estimator Model.” CAPCOA, 2017, available at: <http://www.aqmd.gov/caleemod/home>.

² “California Emissions Estimator Model.” CAPCOA, 2017, available at: <http://www.aqmd.gov/caleemod/home>.

³ “CalEEMod User’s Guide.” CAPCOA, November 2017, available at: http://www.aqmd.gov/docs/default-source/caleemod/01_user-39-s-guide2016-3-2_15november2017.pdf?sfvrsn=4, p. 34.

Specifically, the number and length of vehicle trips is utilized to estimate the vehicle miles travelled (“VMT”) associated with construction. Then, utilizing vehicle-class specific EMFAC 2014 emission factors, CalEEMod calculates the vehicle exhaust, evaporative, and dust emissions resulting from construction-related VMT, including personal vehicles for worker commuting.⁴

Specifically, in order to calculate VMT, CalEEMod multiplies the average daily trip rate by the average overall trip length (see excerpt below):

$$\text{“VMT}_d = \Sigma(\text{Average Daily Trip Rate}_i * \text{Average Overall Trip Length}_i)_n$$

Where:

n = Number of land uses being modeled.”⁵

Furthermore, to calculate the on-road emissions associated with worker trips, CalEEMod utilizes the following equation (see excerpt below):

$$\text{“Emissions}_{\text{pollutant}} = \text{VMT} * \text{EF}_{\text{running,pollutant}}$$

Where:

$\text{Emissions}_{\text{pollutant}}$ = emissions from vehicle running for each pollutant

VMT = vehicle miles traveled

$\text{EF}_{\text{running,pollutant}}$ = emission factor for running emissions.”⁶

Thus, there is a direct relationship between trip length and VMT, as well as a direct relationship between VMT and vehicle running emissions. In other words, when the trip length is increased, the VMT and vehicle running emissions increase as a result. Thus, vehicle running emissions can be reduced by decreasing the average overall trip length, by way of a local hire requirement or otherwise.

Default Worker Trip Parameters and Potential Local Hire Requirements

As previously discussed, the number, length, and vehicle class of worker trips are utilized by CalEEMod to calculate emissions associated with the on-road vehicle trips required to transport workers to and from the Project site during construction.⁷ In order to understand how local hire requirements and associated worker trip length reductions impact GHG emissions calculations, it is important to consider the CalEEMod default worker trip parameters. CalEEMod provides recommended default values based on site-specific information, such as land use type, meteorological data, total lot acreage, project type and typical equipment associated with project type. If more specific project information is known, the user can change the default values and input project-specific values, but the California Environmental Quality Act (“CEQA”) requires that such changes be justified by substantial evidence.⁸ The default number of construction-related worker trips is calculated by multiplying the

⁴ “Appendix A Calculation Details for CalEEMod.” CAPCOA, October 2017, available at: http://www.aqmd.gov/docs/default-source/caleemod/02_appendix-a2016-3-2.pdf?sfvrsn=6, p. 14-15.

⁵ “Appendix A Calculation Details for CalEEMod.” CAPCOA, October 2017, available at: http://www.aqmd.gov/docs/default-source/caleemod/02_appendix-a2016-3-2.pdf?sfvrsn=6, p. 23.

⁶ “Appendix A Calculation Details for CalEEMod.” CAPCOA, October 2017, available at: http://www.aqmd.gov/docs/default-source/caleemod/02_appendix-a2016-3-2.pdf?sfvrsn=6, p. 15.

⁷ “CalEEMod User’s Guide.” CAPCOA, November 2017, available at: http://www.aqmd.gov/docs/default-source/caleemod/01_user-39-s-guide2016-3-2_15november2017.pdf?sfvrsn=4, p. 34.

⁸ CalEEMod User Guide, available at: <http://www.caleemod.com/>, p. 1, 9.

number of pieces of equipment for all phases by 1.25, with the exception of worker trips required for the building construction and architectural coating phases.⁹ Furthermore, the worker trip vehicle class is a 50/25/25 percent mix of light duty autos, light duty truck class 1 and light duty truck class 2, respectively.”¹⁰ Finally, the default worker trip length is consistent with the length of the operational home-to-work vehicle trips.¹¹ The operational home-to-work vehicle trip lengths are:

“[B]ased on the *location* and *urbanization* selected on the project characteristic screen. These values were *supplied by the air districts or use a default average for the state*. Each district (or county) also assigns trip lengths for urban and rural settings” (emphasis added).¹²

Thus, the default worker trip length is based on the location and urbanization level selected by the User when modeling emissions. The below table shows the CalEEMod default rural and urban worker trip lengths by air basin (see excerpt below and Attachment A).¹³

Worker Trip Length by Air Basin		
Air Basin	Rural (miles)	Urban (miles)
Great Basin Valleys	16.8	10.8
Lake County	16.8	10.8
Lake Tahoe	16.8	10.8
Mojave Desert	16.8	10.8
Mountain Counties	16.8	10.8
North Central Coast	17.1	12.3
North Coast	16.8	10.8
Northeast Plateau	16.8	10.8
Sacramento Valley	16.8	10.8
Salton Sea	14.6	11
San Diego	16.8	10.8
San Francisco Bay Area	10.8	10.8
San Joaquin Valley	16.8	10.8
South Central Coast	16.8	10.8
South Coast	19.8	14.7
Average	16.47	11.17
Minimum	10.80	10.80
Maximum	19.80	14.70
Range	9.00	3.90

⁹ “CalEEMod User’s Guide.” CAPCOA, November 2017, available at: http://www.aqmd.gov/docs/default-source/caleemod/01_user-39-s-guide2016-3-2_15november2017.pdf?sfvrsn=4, p. 34.

¹⁰ “Appendix A Calculation Details for CalEEMod.” CAPCOA, October 2017, available at: http://www.aqmd.gov/docs/default-source/caleemod/02_appendix-a2016-3-2.pdf?sfvrsn=6, p. 15.

¹¹ “Appendix A Calculation Details for CalEEMod.” CAPCOA, October 2017, available at: http://www.aqmd.gov/docs/default-source/caleemod/02_appendix-a2016-3-2.pdf?sfvrsn=6, p. 14.

¹² “Appendix A Calculation Details for CalEEMod.” CAPCOA, October 2017, available at: http://www.aqmd.gov/docs/default-source/caleemod/02_appendix-a2016-3-2.pdf?sfvrsn=6, p. 21.

¹³ “Appendix D Default Data Tables.” CAPCOA, October 2017, available at: http://www.aqmd.gov/docs/default-source/caleemod/05_appendix-d2016-3-2.pdf?sfvrsn=4, p. D-84 – D-86.

As demonstrated above, default rural worker trip lengths for air basins in California vary from 10.8- to 19.8- miles, with an average of 16.47 miles. Furthermore, default urban worker trip lengths vary from 10.8- to 14.7- miles, with an average of 11.17 miles. Thus, while default worker trip lengths vary by location, default urban worker trip lengths tend to be shorter in length. Based on these trends evident in the CalEEMod default worker trip lengths, we can reasonably assume that the efficacy of a local hire requirement is especially dependent upon the urbanization of the project site, as well as the project location.

Practical Application of a Local Hire Requirement and Associated Impact

To provide an example of the potential impact of a local hire provision on construction-related GHG emissions, we estimated the significance of a local hire provision for the Village South Specific Plan (“Project”) located in the City of Claremont (“City”). The Project proposed to construct 1,000 residential units, 100,000-SF of retail space, 45,000-SF of office space, as well as a 50-room hotel, on the 24-acre site. The Project location is classified as Urban and lies within the Los Angeles-South Coast County. As a result, the Project has a default worker trip length of 14.7 miles.¹⁴ In an effort to evaluate the potential for a local hire provision to reduce the Project’s construction-related GHG emissions, we prepared an updated model, reducing all worker trip lengths to 10 miles (see Attachment B). Our analysis estimates that if a local hire provision with a 10-mile radius were to be implemented, the GHG emissions associated with Project construction would decrease by approximately 17% (see table below and Attachment C).

Local Hire Provision Net Change	
Without Local Hire Provision	
Total Construction GHG Emissions (MT CO ₂ e)	3,623
Amortized Construction GHG Emissions (MT CO ₂ e/year)	120.77
With Local Hire Provision	
Total Construction GHG Emissions (MT CO ₂ e)	3,024
Amortized Construction GHG Emissions (MT CO ₂ e/year)	100.80
% Decrease in Construction-related GHG Emissions	17%

As demonstrated above, by implementing a local hire provision requiring 10 mile worker trip lengths, the Project could reduce potential GHG emissions associated with construction worker trips. More broadly, any local hire requirement that results in a decreased worker trip length from the default value has the potential to result in a reduction of construction-related GHG emissions, though the significance of the reduction would vary based on the location and urbanization level of the project site.

This serves as an example of the potential impacts of local hire requirements on estimated project-level GHG emissions, though it does not indicate that local hire requirements would result in reduced construction-related GHG emission for all projects. As previously described, the significance of a local hire requirement depends on the worker trip length enforced and the default worker trip length for the project’s urbanization level and location.

¹⁴ “Appendix D Default Data Tables.” CAPCOA, October 2017, available at: http://www.aqmd.gov/docs/default-source/caleemod/05_appendix-d2016-3-2.pdf?sfvrsn=4, p. D-85.

Disclaimer

SWAPE has received limited discovery. Additional information may become available in the future; thus, we retain the right to revise or amend this report when additional information becomes available. Our professional services have been performed using that degree of care and skill ordinarily exercised, under similar circumstances, by reputable environmental consultants practicing in this or similar localities at the time of service. No other warranty, expressed or implied, is made as to the scope of work, work methodologies and protocols, site conditions, analytical testing results, and findings presented. This report reflects efforts which were limited to information that was reasonably accessible at the time of the work, and may contain informational gaps, inconsistencies, or otherwise be incomplete due to the unavailability or uncertainty of information obtained or provided by third parties.

Sincerely,

A handwritten signature in blue ink that reads "Matt Hagemann". The signature is fluid and cursive.

Matt Hagemann, P.G., C.Hg.

A handwritten signature in blue ink that reads "Paul Rosenfeld". The signature is fluid and cursive.

Paul E. Rosenfeld, Ph.D.

Attachment A

Location Type	Location Name	Rural H-W (miles)	Urban H-W (miles)
Air Basin	Great Basin	16.8	10.8
Air Basin	Lake County	16.8	10.8
Air Basin	Lake Tahoe	16.8	10.8
Air Basin	Mojave Desert	16.8	10.8
Air Basin	Mountain	16.8	10.8
Air Basin	North Central	17.1	12.3
Air Basin	North Coast	16.8	10.8
Air Basin	Northeast	16.8	10.8
Air Basin	Sacramento	16.8	10.8
Air Basin	Salton Sea	14.6	11
Air Basin	San Diego	16.8	10.8
Air Basin	San Francisco	10.8	10.8
Air Basin	San Joaquin	16.8	10.8
Air Basin	South Central	16.8	10.8
Air Basin	South Coast	19.8	14.7
Air District	Amador County	16.8	10.8
Air District	Antelope Valley	16.8	10.8
Air District	Bay Area AQMD	10.8	10.8
Air District	Butte County	12.54	12.54
Air District	Calaveras	16.8	10.8
Air District	Colusa County	16.8	10.8
Air District	El Dorado	16.8	10.8
Air District	Feather River	16.8	10.8
Air District	Glenn County	16.8	10.8
Air District	Great Basin	16.8	10.8
Air District	Imperial County	10.2	7.3
Air District	Kern County	16.8	10.8
Air District	Lake County	16.8	10.8
Air District	Lassen County	16.8	10.8
Air District	Mariposa	16.8	10.8
Air District	Mendocino	16.8	10.8
Air District	Modoc County	16.8	10.8
Air District	Mojave Desert	16.8	10.8
Air District	Monterey Bay	16.8	10.8
Air District	North Coast	16.8	10.8
Air District	Northern Sierra	16.8	10.8
Air District	Northern	16.8	10.8
Air District	Placer County	16.8	10.8
Air District	Sacramento	15	10

Air District	San Diego	16.8	10.8
Air District	San Joaquin	16.8	10.8
Air District	San Luis Obispo	13	13
Air District	Santa Barbara	8.3	8.3
Air District	Shasta County	16.8	10.8
Air District	Siskiyou County	16.8	10.8
Air District	South Coast	19.8	14.7
Air District	Tehama County	16.8	10.8
Air District	Tuolumne	16.8	10.8
Air District	Ventura County	16.8	10.8
Air District	Yolo/Solano	15	10
County	Alameda	10.8	10.8
County	Alpine	16.8	10.8
County	Amador	16.8	10.8
County	Butte	12.54	12.54
County	Calaveras	16.8	10.8
County	Colusa	16.8	10.8
County	Contra Costa	10.8	10.8
County	Del Norte	16.8	10.8
County	El Dorado-Lake	16.8	10.8
County	El Dorado-	16.8	10.8
County	Fresno	16.8	10.8
County	Glenn	16.8	10.8
County	Humboldt	16.8	10.8
County	Imperial	10.2	7.3
County	Inyo	16.8	10.8
County	Kern-Mojave	16.8	10.8
County	Kern-San	16.8	10.8
County	Kings	16.8	10.8
County	Lake	16.8	10.8
County	Lassen	16.8	10.8
County	Los Angeles-	16.8	10.8
County	Los Angeles-	19.8	14.7
County	Madera	16.8	10.8
County	Marin	10.8	10.8
County	Mariposa	16.8	10.8
County	Mendocino-	16.8	10.8
County	Mendocino-	16.8	10.8
County	Mendocino-	16.8	10.8
County	Mendocino-	16.8	10.8
County	Merced	16.8	10.8
County	Modoc	16.8	10.8
County	Mono	16.8	10.8
County	Monterey	16.8	10.8
County	Napa	10.8	10.8

County	Nevada	16.8	10.8
County	Orange	19.8	14.7
County	Placer-Lake	16.8	10.8
County	Placer-Mountain	16.8	10.8
County	Placer-	16.8	10.8
County	Plumas	16.8	10.8
County	Riverside-	16.8	10.8
County	Riverside-	19.8	14.7
County	Riverside-Salton	14.6	11
County	Riverside-South	19.8	14.7
County	Sacramento	15	10
County	San Benito	16.8	10.8
County	San Bernardino-	16.8	10.8
County	San Bernardino-	19.8	14.7
County	San Diego	16.8	10.8
County	San Francisco	10.8	10.8
County	San Joaquin	16.8	10.8
County	San Luis Obispo	13	13
County	San Mateo	10.8	10.8
County	Santa Barbara-	8.3	8.3
County	Santa Barbara-	8.3	8.3
County	Santa Clara	10.8	10.8
County	Santa Cruz	16.8	10.8
County	Shasta	16.8	10.8
County	Sierra	16.8	10.8
County	Siskiyou	16.8	10.8
County	Solano-	15	10
County	Solano-San	16.8	10.8
County	Sonoma-North	16.8	10.8
County	Sonoma-San	10.8	10.8
County	Stanislaus	16.8	10.8
County	Sutter	16.8	10.8
County	Tehama	16.8	10.8
County	Trinity	16.8	10.8
County	Tulare	16.8	10.8
County	Tuolumne	16.8	10.8
County	Ventura	16.8	10.8
County	Yolo	15	10
County	Yuba	16.8	10.8
Statewide	Statewide	16.8	10.8

Worker Trip Length by Air Basin		
Air Basin	Rural (miles)	Urban (miles)
Great Basin Valleys	16.8	10.8
Lake County	16.8	10.8
Lake Tahoe	16.8	10.8
Mojave Desert	16.8	10.8
Mountain Counties	16.8	10.8
North Central Coast	17.1	12.3
North Coast	16.8	10.8
Northeast Plateau	16.8	10.8
Sacramento Valley	16.8	10.8
Salton Sea	14.6	11
San Diego	16.8	10.8
San Francisco Bay Area	10.8	10.8
San Joaquin Valley	16.8	10.8
South Central Coast	16.8	10.8
South Coast	19.8	14.7
Average	16.47	11.17
Minimum	10.80	10.80
Maximum	19.80	14.70
Range	9.00	3.90

Village South Specific Plan (Proposed) - Los Angeles-South Coast County, Annual

Village South Specific Plan (Proposed)
Los Angeles-South Coast County, Annual

1.0 Project Characteristics**1.1 Land Usage**

Land Uses	Size	Metric	Lot Acreage	Floor Surface Area	Population
General Office Building	45.00	1000sqft	1.03	45,000.00	0
High Turnover (Sit Down Restaurant)	36.00	1000sqft	0.83	36,000.00	0
Hotel	50.00	Room	1.67	72,600.00	0
Quality Restaurant	8.00	1000sqft	0.18	8,000.00	0
Apartments Low Rise	25.00	Dwelling Unit	1.56	25,000.00	72
Apartments Mid Rise	975.00	Dwelling Unit	25.66	975,000.00	2789
Regional Shopping Center	56.00	1000sqft	1.29	56,000.00	0

1.2 Other Project Characteristics

Urbanization	Urban	Wind Speed (m/s)	2.2	Precipitation Freq (Days)	33
Climate Zone	9			Operational Year	2028
Utility Company	Southern California Edison				
CO2 Intensity (lb/MWhr)	702.44	CH4 Intensity (lb/MWhr)	0.029	N2O Intensity (lb/MWhr)	0.006

1.3 User Entered Comments & Non-Default Data

Village South Specific Plan (Proposed) - Los Angeles-South Coast County, Annual

Project Characteristics - Consistent with the DEIR's model.

Land Use - See SWAPE comment regarding residential and retail land uses.

Construction Phase - See SWAPE comment regarding individual construction phase lengths.

Demolition - Consistent with the DEIR's model. See SWAPE comment regarding demolition.

Vehicle Trips - Saturday trips consistent with the DEIR's model. See SWAPE comment regarding weekday and Sunday trips.

Woodstoves - Woodstoves and wood-burning fireplaces consistent with the DEIR's model. See SWAPE comment regarding gas fireplaces.

Energy Use -

Construction Off-road Equipment Mitigation - See SWAPE comment on construction-related mitigation.

Area Mitigation - See SWAPE comment regarding operational mitigation measures.

Water Mitigation - See SWAPE comment regarding operational mitigation measures.

Table Name	Column Name	Default Value	New Value
tblFireplaces	FireplaceWoodMass	1,019.20	0.00
tblFireplaces	FireplaceWoodMass	1,019.20	0.00
tblFireplaces	NumberWood	1.25	0.00
tblFireplaces	NumberWood	48.75	0.00
tblVehicleTrips	ST_TR	7.16	6.17
tblVehicleTrips	ST_TR	6.39	3.87
tblVehicleTrips	ST_TR	2.46	1.39
tblVehicleTrips	ST_TR	158.37	79.82
tblVehicleTrips	ST_TR	8.19	3.75
tblVehicleTrips	ST_TR	94.36	63.99
tblVehicleTrips	ST_TR	49.97	10.74
tblVehicleTrips	SU_TR	6.07	6.16
tblVehicleTrips	SU_TR	5.86	4.18
tblVehicleTrips	SU_TR	1.05	0.69
tblVehicleTrips	SU_TR	131.84	78.27

Village South Specific Plan (Proposed) - Los Angeles-South Coast County, Annual

tblVehicleTrips	SU_TR	5.95	3.20
tblVehicleTrips	SU_TR	72.16	57.65
tblVehicleTrips	SU_TR	25.24	6.39
tblVehicleTrips	WD_TR	6.59	5.83
tblVehicleTrips	WD_TR	6.65	4.13
tblVehicleTrips	WD_TR	11.03	6.41
tblVehicleTrips	WD_TR	127.15	65.80
tblVehicleTrips	WD_TR	8.17	3.84
tblVehicleTrips	WD_TR	89.95	62.64
tblVehicleTrips	WD_TR	42.70	9.43
tblWoodstoves	NumberCatalytic	1.25	0.00
tblWoodstoves	NumberCatalytic	48.75	0.00
tblWoodstoves	NumberNoncatalytic	1.25	0.00
tblWoodstoves	NumberNoncatalytic	48.75	0.00
tblWoodstoves	WoodstoveDayYear	25.00	0.00
tblWoodstoves	WoodstoveDayYear	25.00	0.00
tblWoodstoves	WoodstoveWoodMass	999.60	0.00
tblWoodstoves	WoodstoveWoodMass	999.60	0.00

2.0 Emissions Summary

Village South Specific Plan (Proposed) - Los Angeles-South Coast County, Annual

2.1 Overall Construction

Unmitigated Construction

	ROG	NOx	CO	SO2	Fugitive PM10	Exhaust PM10	PM10 Total	Fugitive PM2.5	Exhaust PM2.5	PM2.5 Total	Bio- CO2	NBio- CO2	Total CO2	CH4	N2O	CO2e
Year	tons/yr										MT/yr					
2021	0.1713	1.8242	1.1662	2.4000e-003	0.4169	0.0817	0.4986	0.1795	0.0754	0.2549	0.0000	213.1969	213.1969	0.0601	0.0000	214.6993
2022	0.6904	4.1142	6.1625	0.0189	1.3058	0.1201	1.4259	0.3460	0.1128	0.4588	0.0000	1,721.6826	1,721.6826	0.1294	0.0000	1,724.9187
2023	0.6148	3.3649	5.6747	0.0178	1.1963	0.0996	1.2959	0.3203	0.0935	0.4138	0.0000	1,627.5295	1,627.5295	0.1185	0.0000	1,630.4925
2024	4.1619	0.1335	0.2810	5.9000e-004	0.0325	6.4700e-003	0.0390	8.6300e-003	6.0400e-003	0.0147	0.0000	52.9078	52.9078	8.0200e-003	0.0000	53.1082
Maximum	4.1619	4.1142	6.1625	0.0189	1.3058	0.1201	1.4259	0.3460	0.1128	0.4588	0.0000	1,721.6826	1,721.6826	0.1294	0.0000	1,724.9187

Village South Specific Plan (Proposed) - Los Angeles-South Coast County, Annual

2.1 Overall Construction

Mitigated Construction

	ROG	NOx	CO	SO2	Fugitive PM10	Exhaust PM10	PM10 Total	Fugitive PM2.5	Exhaust PM2.5	PM2.5 Total	Bio- CO2	NBio- CO2	Total CO2	CH4	N2O	CO2e
Year	tons/yr										MT/yr					
2021	0.1713	1.8242	1.1662	2.4000e-003	0.4169	0.0817	0.4986	0.1795	0.0754	0.2549	0.0000	213.1967	213.1967	0.0601	0.0000	214.6991
2022	0.6904	4.1142	6.1625	0.0189	1.3058	0.1201	1.4259	0.3460	0.1128	0.4588	0.0000	1,721.6823	1,721.6823	0.1294	0.0000	1,724.9183
2023	0.6148	3.3648	5.6747	0.0178	1.1963	0.0996	1.2959	0.3203	0.0935	0.4138	0.0000	1,627.5291	1,627.5291	0.1185	0.0000	1,630.4921
2024	4.1619	0.1335	0.2810	5.9000e-004	0.0325	6.4700e-003	0.0390	8.6300e-003	6.0400e-003	0.0147	0.0000	52.9077	52.9077	8.0200e-003	0.0000	53.1082
Maximum	4.1619	4.1142	6.1625	0.0189	1.3058	0.1201	1.4259	0.3460	0.1128	0.4588	0.0000	1,721.6823	1,721.6823	0.1294	0.0000	1,724.9183

	ROG	NOx	CO	SO2	Fugitive PM10	Exhaust PM10	PM10 Total	Fugitive PM2.5	Exhaust PM2.5	PM2.5 Total	Bio- CO2	NBio- CO2	Total CO2	CH4	N2O	CO2e
Percent Reduction	0.00	0.00	0.00	0.00	0.00	0.00	0.00	0.00	0.00	0.00	0.00	0.00	0.00	0.00	0.00	0.00

Quarter	Start Date	End Date	Maximum Unmitigated ROG + NOX (tons/quarter)	Maximum Mitigated ROG + NOX (tons/quarter)
1	9-1-2021	11-30-2021	1.4103	1.4103
2	12-1-2021	2-28-2022	1.3613	1.3613
3	3-1-2022	5-31-2022	1.1985	1.1985
4	6-1-2022	8-31-2022	1.1921	1.1921
5	9-1-2022	11-30-2022	1.1918	1.1918
6	12-1-2022	2-28-2023	1.0774	1.0774
7	3-1-2023	5-31-2023	1.0320	1.0320
8	6-1-2023	8-31-2023	1.0260	1.0260

Village South Specific Plan (Proposed) - Los Angeles-South Coast County, Annual

9	9-1-2023	11-30-2023	1.0265	1.0265
10	12-1-2023	2-29-2024	2.8857	2.8857
11	3-1-2024	5-31-2024	1.6207	1.6207
		Highest	2.8857	2.8857

2.2 Overall Operational
Unmitigated Operational

	ROG	NOx	CO	SO2	Fugitive PM10	Exhaust PM10	PM10 Total	Fugitive PM2.5	Exhaust PM2.5	PM2.5 Total	Bio- CO2	NBio- CO2	Total CO2	CH4	N2O	CO2e
Category	tons/yr										MT/yr					
Area	5.1437	0.2950	10.3804	1.6700e-003		0.0714	0.0714		0.0714	0.0714	0.0000	220.9670	220.9670	0.0201	3.7400e-003	222.5835
Energy	0.1398	1.2312	0.7770	7.6200e-003		0.0966	0.0966		0.0966	0.0966	0.0000	3,896.0732	3,896.0732	0.1303	0.0468	3,913.2833
Mobile	1.5857	7.9962	19.1834	0.0821	7.7979	0.0580	7.8559	2.0895	0.0539	2.1434	0.0000	7,620.4986	7,620.4986	0.3407	0.0000	7,629.0162
Waste						0.0000	0.0000		0.0000	0.0000	207.8079	0.0000	207.8079	12.2811	0.0000	514.8354
Water						0.0000	0.0000		0.0000	0.0000	29.1632	556.6420	585.8052	3.0183	0.0755	683.7567
Total	6.8692	9.5223	30.3407	0.0914	7.7979	0.2260	8.0240	2.0895	0.2219	2.3114	236.9712	12,294.1807	12,531.1519	15.7904	0.1260	12,963.4751

Village South Specific Plan (Proposed) - Los Angeles-South Coast County, Annual

2.2 Overall Operational

Mitigated Operational

	ROG	NOx	CO	SO2	Fugitive PM10	Exhaust PM10	PM10 Total	Fugitive PM2.5	Exhaust PM2.5	PM2.5 Total	Bio- CO2	NBio- CO2	Total CO2	CH4	N2O	CO2e
Category	tons/yr										MT/yr					
Area	5.1437	0.2950	10.3804	1.6700e-003		0.0714	0.0714		0.0714	0.0714	0.0000	220.9670	220.9670	0.0201	3.7400e-003	222.5835
Energy	0.1398	1.2312	0.7770	7.6200e-003		0.0966	0.0966		0.0966	0.0966	0.0000	3,896.0732	3,896.0732	0.1303	0.0468	3,913.2833
Mobile	1.5857	7.9962	19.1834	0.0821	7.7979	0.0580	7.8559	2.0895	0.0539	2.1434	0.0000	7,620.4986	7,620.4986	0.3407	0.0000	7,629.0162
Waste						0.0000	0.0000		0.0000	0.0000	207.8079	0.0000	207.8079	12.2811	0.0000	514.8354
Water						0.0000	0.0000		0.0000	0.0000	29.1632	556.6420	585.8052	3.0183	0.0755	683.7567
Total	6.8692	9.5223	30.3407	0.0914	7.7979	0.2260	8.0240	2.0895	0.2219	2.3114	236.9712	12,294.1807	12,531.1519	15.7904	0.1260	12,963.4751

	ROG	NOx	CO	SO2	Fugitive PM10	Exhaust PM10	PM10 Total	Fugitive PM2.5	Exhaust PM2.5	PM2.5 Total	Bio- CO2	NBio- CO2	Total CO2	CH4	N2O	CO2e
Percent Reduction	0.00	0.00	0.00	0.00	0.00	0.00	0.00	0.00	0.00	0.00	0.00	0.00	0.00	0.00	0.00	0.00

3.0 Construction Detail

Construction Phase

Village South Specific Plan (Proposed) - Los Angeles-South Coast County, Annual

Phase Number	Phase Name	Phase Type	Start Date	End Date	Num Days Week	Num Days	Phase Description
1	Demolition	Demolition	9/1/2021	10/12/2021	5	30	
2	Site Preparation	Site Preparation	10/13/2021	11/9/2021	5	20	
3	Grading	Grading	11/10/2021	1/11/2022	5	45	
4	Building Construction	Building Construction	1/12/2022	12/12/2023	5	500	
5	Paving	Paving	12/13/2023	1/30/2024	5	35	
6	Architectural Coating	Architectural Coating	1/31/2024	3/19/2024	5	35	

Acres of Grading (Site Preparation Phase): 0

Acres of Grading (Grading Phase): 112.5

Acres of Paving: 0

Residential Indoor: 2,025,000; Residential Outdoor: 675,000; Non-Residential Indoor: 326,400; Non-Residential Outdoor: 108,800; Striped Parking Area: 0 (Architectural Coating – sqft)

OffRoad Equipment

Village South Specific Plan (Proposed) - Los Angeles-South Coast County, Annual

Phase Name	Offroad Equipment Type	Amount	Usage Hours	Horse Power	Load Factor
Demolition	Concrete/Industrial Saws	1	8.00	81	0.73
Demolition	Excavators	3	8.00	158	0.38
Demolition	Rubber Tired Dozers	2	8.00	247	0.40
Site Preparation	Rubber Tired Dozers	3	8.00	247	0.40
Site Preparation	Tractors/Loaders/Backhoes	4	8.00	97	0.37
Grading	Excavators	2	8.00	158	0.38
Grading	Graders	1	8.00	187	0.41
Grading	Rubber Tired Dozers	1	8.00	247	0.40
Grading	Scrapers	2	8.00	367	0.48
Grading	Tractors/Loaders/Backhoes	2	8.00	97	0.37
Building Construction	Cranes	1	7.00	231	0.29
Building Construction	Forklifts	3	8.00	89	0.20
Building Construction	Generator Sets	1	8.00	84	0.74
Building Construction	Tractors/Loaders/Backhoes	3	7.00	97	0.37
Building Construction	Welders	1	8.00	46	0.45
Paving	Pavers	2	8.00	130	0.42
Paving	Paving Equipment	2	8.00	132	0.36
Paving	Rollers	2	8.00	80	0.38
Architectural Coating	Air Compressors	1	6.00	78	0.48

Trips and VMT

Village South Specific Plan (Proposed) - Los Angeles-South Coast County, Annual

Phase Name	Offroad Equipment Count	Worker Trip Number	Vendor Trip Number	Hauling Trip Number	Worker Trip Length	Vendor Trip Length	Hauling Trip Length	Worker Vehicle Class	Vendor Vehicle Class	Hauling Vehicle Class
Demolition	6	15.00	0.00	458.00	14.70	6.90	20.00	LD_Mix	HDT_Mix	HHDT
Site Preparation	7	18.00	0.00	0.00	14.70	6.90	20.00	LD_Mix	HDT_Mix	HHDT
Grading	8	20.00	0.00	0.00	14.70	6.90	20.00	LD_Mix	HDT_Mix	HHDT
Building Construction	9	801.00	143.00	0.00	14.70	6.90	20.00	LD_Mix	HDT_Mix	HHDT
Paving	6	15.00	0.00	0.00	14.70	6.90	20.00	LD_Mix	HDT_Mix	HHDT
Architectural Coating	1	160.00	0.00	0.00	14.70	6.90	20.00	LD_Mix	HDT_Mix	HHDT

3.1 Mitigation Measures Construction

3.2 Demolition - 2021

Unmitigated Construction On-Site

	ROG	NOx	CO	SO2	Fugitive PM10	Exhaust PM10	PM10 Total	Fugitive PM2.5	Exhaust PM2.5	PM2.5 Total	Bio- CO2	NBio- CO2	Total CO2	CH4	N2O	CO2e
Category	tons/yr										MT/yr					
Fugitive Dust					0.0496	0.0000	0.0496	7.5100e-003	0.0000	7.5100e-003	0.0000	0.0000	0.0000	0.0000	0.0000	0.0000
Off-Road	0.0475	0.4716	0.3235	5.8000e-004		0.0233	0.0233		0.0216	0.0216	0.0000	51.0012	51.0012	0.0144	0.0000	51.3601
Total	0.0475	0.4716	0.3235	5.8000e-004	0.0496	0.0233	0.0729	7.5100e-003	0.0216	0.0291	0.0000	51.0012	51.0012	0.0144	0.0000	51.3601

Village South Specific Plan (Proposed) - Los Angeles-South Coast County, Annual

3.2 Demolition - 2021

Unmitigated Construction Off-Site

	ROG	NOx	CO	SO2	Fugitive PM10	Exhaust PM10	PM10 Total	Fugitive PM2.5	Exhaust PM2.5	PM2.5 Total	Bio- CO2	NBio- CO2	Total CO2	CH4	N2O	CO2e
Category	tons/yr										MT/yr					
Hauling	1.9300e-003	0.0634	0.0148	1.8000e-004	3.9400e-003	1.9000e-004	4.1300e-003	1.0800e-003	1.8000e-004	1.2600e-003	0.0000	17.4566	17.4566	1.2100e-003	0.0000	17.4869
Vendor	0.0000	0.0000	0.0000	0.0000	0.0000	0.0000	0.0000	0.0000	0.0000	0.0000	0.0000	0.0000	0.0000	0.0000	0.0000	0.0000
Worker	9.7000e-004	7.5000e-004	8.5100e-003	2.0000e-005	2.4700e-003	2.0000e-005	2.4900e-003	6.5000e-004	2.0000e-005	6.7000e-004	0.0000	2.2251	2.2251	7.0000e-005	0.0000	2.2267
Total	2.9000e-003	0.0641	0.0233	2.0000e-004	6.4100e-003	2.1000e-004	6.6200e-003	1.7300e-003	2.0000e-004	1.9300e-003	0.0000	19.6816	19.6816	1.2800e-003	0.0000	19.7136

Mitigated Construction On-Site

	ROG	NOx	CO	SO2	Fugitive PM10	Exhaust PM10	PM10 Total	Fugitive PM2.5	Exhaust PM2.5	PM2.5 Total	Bio- CO2	NBio- CO2	Total CO2	CH4	N2O	CO2e
Category	tons/yr										MT/yr					
Fugitive Dust					0.0496	0.0000	0.0496	7.5100e-003	0.0000	7.5100e-003	0.0000	0.0000	0.0000	0.0000	0.0000	0.0000
Off-Road	0.0475	0.4716	0.3235	5.8000e-004		0.0233	0.0233		0.0216	0.0216	0.0000	51.0011	51.0011	0.0144	0.0000	51.3600
Total	0.0475	0.4716	0.3235	5.8000e-004	0.0496	0.0233	0.0729	7.5100e-003	0.0216	0.0291	0.0000	51.0011	51.0011	0.0144	0.0000	51.3600

Village South Specific Plan (Proposed) - Los Angeles-South Coast County, Annual

3.2 Demolition - 2021

Mitigated Construction Off-Site

	ROG	NOx	CO	SO2	Fugitive PM10	Exhaust PM10	PM10 Total	Fugitive PM2.5	Exhaust PM2.5	PM2.5 Total	Bio- CO2	NBio- CO2	Total CO2	CH4	N2O	CO2e
Category	tons/yr										MT/yr					
Hauling	1.9300e-003	0.0634	0.0148	1.8000e-004	3.9400e-003	1.9000e-004	4.1300e-003	1.0800e-003	1.8000e-004	1.2600e-003	0.0000	17.4566	17.4566	1.2100e-003	0.0000	17.4869
Vendor	0.0000	0.0000	0.0000	0.0000	0.0000	0.0000	0.0000	0.0000	0.0000	0.0000	0.0000	0.0000	0.0000	0.0000	0.0000	0.0000
Worker	9.7000e-004	7.5000e-004	8.5100e-003	2.0000e-005	2.4700e-003	2.0000e-005	2.4900e-003	6.5000e-004	2.0000e-005	6.7000e-004	0.0000	2.2251	2.2251	7.0000e-005	0.0000	2.2267
Total	2.9000e-003	0.0641	0.0233	2.0000e-004	6.4100e-003	2.1000e-004	6.6200e-003	1.7300e-003	2.0000e-004	1.9300e-003	0.0000	19.6816	19.6816	1.2800e-003	0.0000	19.7136

3.3 Site Preparation - 2021

Unmitigated Construction On-Site

	ROG	NOx	CO	SO2	Fugitive PM10	Exhaust PM10	PM10 Total	Fugitive PM2.5	Exhaust PM2.5	PM2.5 Total	Bio- CO2	NBio- CO2	Total CO2	CH4	N2O	CO2e
Category	tons/yr										MT/yr					
Fugitive Dust					0.1807	0.0000	0.1807	0.0993	0.0000	0.0993	0.0000	0.0000	0.0000	0.0000	0.0000	0.0000
Off-Road	0.0389	0.4050	0.2115	3.8000e-004		0.0204	0.0204		0.0188	0.0188	0.0000	33.4357	33.4357	0.0108	0.0000	33.7061
Total	0.0389	0.4050	0.2115	3.8000e-004	0.1807	0.0204	0.2011	0.0993	0.0188	0.1181	0.0000	33.4357	33.4357	0.0108	0.0000	33.7061

Village South Specific Plan (Proposed) - Los Angeles-South Coast County, Annual

3.3 Site Preparation - 2021

Unmitigated Construction Off-Site

	ROG	NOx	CO	SO2	Fugitive PM10	Exhaust PM10	PM10 Total	Fugitive PM2.5	Exhaust PM2.5	PM2.5 Total	Bio- CO2	NBio- CO2	Total CO2	CH4	N2O	CO2e
Category	tons/yr										MT/yr					
Hauling	0.0000	0.0000	0.0000	0.0000	0.0000	0.0000	0.0000	0.0000	0.0000	0.0000	0.0000	0.0000	0.0000	0.0000	0.0000	0.0000
Vendor	0.0000	0.0000	0.0000	0.0000	0.0000	0.0000	0.0000	0.0000	0.0000	0.0000	0.0000	0.0000	0.0000	0.0000	0.0000	0.0000
Worker	7.7000e-004	6.0000e-004	6.8100e-003	2.0000e-005	1.9700e-003	2.0000e-005	1.9900e-003	5.2000e-004	1.0000e-005	5.4000e-004	0.0000	1.7801	1.7801	5.0000e-005	0.0000	1.7814
Total	7.7000e-004	6.0000e-004	6.8100e-003	2.0000e-005	1.9700e-003	2.0000e-005	1.9900e-003	5.2000e-004	1.0000e-005	5.4000e-004	0.0000	1.7801	1.7801	5.0000e-005	0.0000	1.7814

Mitigated Construction On-Site

	ROG	NOx	CO	SO2	Fugitive PM10	Exhaust PM10	PM10 Total	Fugitive PM2.5	Exhaust PM2.5	PM2.5 Total	Bio- CO2	NBio- CO2	Total CO2	CH4	N2O	CO2e
Category	tons/yr										MT/yr					
Fugitive Dust					0.1807	0.0000	0.1807	0.0993	0.0000	0.0993	0.0000	0.0000	0.0000	0.0000	0.0000	0.0000
Off-Road	0.0389	0.4050	0.2115	3.8000e-004		0.0204	0.0204		0.0188	0.0188	0.0000	33.4357	33.4357	0.0108	0.0000	33.7060
Total	0.0389	0.4050	0.2115	3.8000e-004	0.1807	0.0204	0.2011	0.0993	0.0188	0.1181	0.0000	33.4357	33.4357	0.0108	0.0000	33.7060

Village South Specific Plan (Proposed) - Los Angeles-South Coast County, Annual

3.3 Site Preparation - 2021

Mitigated Construction Off-Site

	ROG	NOx	CO	SO2	Fugitive PM10	Exhaust PM10	PM10 Total	Fugitive PM2.5	Exhaust PM2.5	PM2.5 Total	Bio- CO2	NBio- CO2	Total CO2	CH4	N2O	CO2e
Category	tons/yr										MT/yr					
Hauling	0.0000	0.0000	0.0000	0.0000	0.0000	0.0000	0.0000	0.0000	0.0000	0.0000	0.0000	0.0000	0.0000	0.0000	0.0000	0.0000
Vendor	0.0000	0.0000	0.0000	0.0000	0.0000	0.0000	0.0000	0.0000	0.0000	0.0000	0.0000	0.0000	0.0000	0.0000	0.0000	0.0000
Worker	7.7000e-004	6.0000e-004	6.8100e-003	2.0000e-005	1.9700e-003	2.0000e-005	1.9900e-003	5.2000e-004	1.0000e-005	5.4000e-004	0.0000	1.7801	1.7801	5.0000e-005	0.0000	1.7814
Total	7.7000e-004	6.0000e-004	6.8100e-003	2.0000e-005	1.9700e-003	2.0000e-005	1.9900e-003	5.2000e-004	1.0000e-005	5.4000e-004	0.0000	1.7801	1.7801	5.0000e-005	0.0000	1.7814

3.4 Grading - 2021

Unmitigated Construction On-Site

	ROG	NOx	CO	SO2	Fugitive PM10	Exhaust PM10	PM10 Total	Fugitive PM2.5	Exhaust PM2.5	PM2.5 Total	Bio- CO2	NBio- CO2	Total CO2	CH4	N2O	CO2e
Category	tons/yr										MT/yr					
Fugitive Dust					0.1741	0.0000	0.1741	0.0693	0.0000	0.0693	0.0000	0.0000	0.0000	0.0000	0.0000	0.0000
Off-Road	0.0796	0.8816	0.5867	1.1800e-003		0.0377	0.0377		0.0347	0.0347	0.0000	103.5405	103.5405	0.0335	0.0000	104.3776
Total	0.0796	0.8816	0.5867	1.1800e-003	0.1741	0.0377	0.2118	0.0693	0.0347	0.1040	0.0000	103.5405	103.5405	0.0335	0.0000	104.3776

Village South Specific Plan (Proposed) - Los Angeles-South Coast County, Annual

3.4 Grading - 2021

Unmitigated Construction Off-Site

	ROG	NOx	CO	SO2	Fugitive PM10	Exhaust PM10	PM10 Total	Fugitive PM2.5	Exhaust PM2.5	PM2.5 Total	Bio- CO2	NBio- CO2	Total CO2	CH4	N2O	CO2e
Category	tons/yr										MT/yr					
Hauling	0.0000	0.0000	0.0000	0.0000	0.0000	0.0000	0.0000	0.0000	0.0000	0.0000	0.0000	0.0000	0.0000	0.0000	0.0000	0.0000
Vendor	0.0000	0.0000	0.0000	0.0000	0.0000	0.0000	0.0000	0.0000	0.0000	0.0000	0.0000	0.0000	0.0000	0.0000	0.0000	0.0000
Worker	1.6400e-003	1.2700e-003	0.0144	4.0000e-005	4.1600e-003	3.0000e-005	4.2000e-003	1.1100e-003	3.0000e-005	1.1400e-003	0.0000	3.7579	3.7579	1.1000e-004	0.0000	3.7607
Total	1.6400e-003	1.2700e-003	0.0144	4.0000e-005	4.1600e-003	3.0000e-005	4.2000e-003	1.1100e-003	3.0000e-005	1.1400e-003	0.0000	3.7579	3.7579	1.1000e-004	0.0000	3.7607

Mitigated Construction On-Site

	ROG	NOx	CO	SO2	Fugitive PM10	Exhaust PM10	PM10 Total	Fugitive PM2.5	Exhaust PM2.5	PM2.5 Total	Bio- CO2	NBio- CO2	Total CO2	CH4	N2O	CO2e
Category	tons/yr										MT/yr					
Fugitive Dust					0.1741	0.0000	0.1741	0.0693	0.0000	0.0693	0.0000	0.0000	0.0000	0.0000	0.0000	0.0000
Off-Road	0.0796	0.8816	0.5867	1.1800e-003		0.0377	0.0377		0.0347	0.0347	0.0000	103.5403	103.5403	0.0335	0.0000	104.3775
Total	0.0796	0.8816	0.5867	1.1800e-003	0.1741	0.0377	0.2118	0.0693	0.0347	0.1040	0.0000	103.5403	103.5403	0.0335	0.0000	104.3775

Village South Specific Plan (Proposed) - Los Angeles-South Coast County, Annual

3.4 Grading - 2021

Mitigated Construction Off-Site

	ROG	NOx	CO	SO2	Fugitive PM10	Exhaust PM10	PM10 Total	Fugitive PM2.5	Exhaust PM2.5	PM2.5 Total	Bio- CO2	NBio- CO2	Total CO2	CH4	N2O	CO2e
Category	tons/yr										MT/yr					
Hauling	0.0000	0.0000	0.0000	0.0000	0.0000	0.0000	0.0000	0.0000	0.0000	0.0000	0.0000	0.0000	0.0000	0.0000	0.0000	0.0000
Vendor	0.0000	0.0000	0.0000	0.0000	0.0000	0.0000	0.0000	0.0000	0.0000	0.0000	0.0000	0.0000	0.0000	0.0000	0.0000	0.0000
Worker	1.6400e-003	1.2700e-003	0.0144	4.0000e-005	4.1600e-003	3.0000e-005	4.2000e-003	1.1100e-003	3.0000e-005	1.1400e-003	0.0000	3.7579	3.7579	1.1000e-004	0.0000	3.7607
Total	1.6400e-003	1.2700e-003	0.0144	4.0000e-005	4.1600e-003	3.0000e-005	4.2000e-003	1.1100e-003	3.0000e-005	1.1400e-003	0.0000	3.7579	3.7579	1.1000e-004	0.0000	3.7607

3.4 Grading - 2022

Unmitigated Construction On-Site

	ROG	NOx	CO	SO2	Fugitive PM10	Exhaust PM10	PM10 Total	Fugitive PM2.5	Exhaust PM2.5	PM2.5 Total	Bio- CO2	NBio- CO2	Total CO2	CH4	N2O	CO2e
Category	tons/yr										MT/yr					
Fugitive Dust					0.0807	0.0000	0.0807	0.0180	0.0000	0.0180	0.0000	0.0000	0.0000	0.0000	0.0000	0.0000
Off-Road	0.0127	0.1360	0.1017	2.2000e-004		5.7200e-003	5.7200e-003		5.2600e-003	5.2600e-003	0.0000	19.0871	19.0871	6.1700e-003	0.0000	19.2414
Total	0.0127	0.1360	0.1017	2.2000e-004	0.0807	5.7200e-003	0.0865	0.0180	5.2600e-003	0.0233	0.0000	19.0871	19.0871	6.1700e-003	0.0000	19.2414

Village South Specific Plan (Proposed) - Los Angeles-South Coast County, Annual

3.4 Grading - 2022

Unmitigated Construction Off-Site

	ROG	NOx	CO	SO2	Fugitive PM10	Exhaust PM10	PM10 Total	Fugitive PM2.5	Exhaust PM2.5	PM2.5 Total	Bio- CO2	NBio- CO2	Total CO2	CH4	N2O	CO2e
Category	tons/yr										MT/yr					
Hauling	0.0000	0.0000	0.0000	0.0000	0.0000	0.0000	0.0000	0.0000	0.0000	0.0000	0.0000	0.0000	0.0000	0.0000	0.0000	0.0000
Vendor	0.0000	0.0000	0.0000	0.0000	0.0000	0.0000	0.0000	0.0000	0.0000	0.0000	0.0000	0.0000	0.0000	0.0000	0.0000	0.0000
Worker	2.8000e-004	2.1000e-004	2.4400e-003	1.0000e-005	7.7000e-004	1.0000e-005	7.7000e-004	2.0000e-004	1.0000e-005	2.1000e-004	0.0000	0.6679	0.6679	2.0000e-005	0.0000	0.6684
Total	2.8000e-004	2.1000e-004	2.4400e-003	1.0000e-005	7.7000e-004	1.0000e-005	7.7000e-004	2.0000e-004	1.0000e-005	2.1000e-004	0.0000	0.6679	0.6679	2.0000e-005	0.0000	0.6684

Mitigated Construction On-Site

	ROG	NOx	CO	SO2	Fugitive PM10	Exhaust PM10	PM10 Total	Fugitive PM2.5	Exhaust PM2.5	PM2.5 Total	Bio- CO2	NBio- CO2	Total CO2	CH4	N2O	CO2e
Category	tons/yr										MT/yr					
Fugitive Dust					0.0807	0.0000	0.0807	0.0180	0.0000	0.0180	0.0000	0.0000	0.0000	0.0000	0.0000	0.0000
Off-Road	0.0127	0.1360	0.1017	2.2000e-004		5.7200e-003	5.7200e-003		5.2600e-003	5.2600e-003	0.0000	19.0871	19.0871	6.1700e-003	0.0000	19.2414
Total	0.0127	0.1360	0.1017	2.2000e-004	0.0807	5.7200e-003	0.0865	0.0180	5.2600e-003	0.0233	0.0000	19.0871	19.0871	6.1700e-003	0.0000	19.2414

Village South Specific Plan (Proposed) - Los Angeles-South Coast County, Annual

3.4 Grading - 2022

Mitigated Construction Off-Site

	ROG	NOx	CO	SO2	Fugitive PM10	Exhaust PM10	PM10 Total	Fugitive PM2.5	Exhaust PM2.5	PM2.5 Total	Bio- CO2	NBio- CO2	Total CO2	CH4	N2O	CO2e
Category	tons/yr										MT/yr					
Hauling	0.0000	0.0000	0.0000	0.0000	0.0000	0.0000	0.0000	0.0000	0.0000	0.0000	0.0000	0.0000	0.0000	0.0000	0.0000	0.0000
Vendor	0.0000	0.0000	0.0000	0.0000	0.0000	0.0000	0.0000	0.0000	0.0000	0.0000	0.0000	0.0000	0.0000	0.0000	0.0000	0.0000
Worker	2.8000e-004	2.1000e-004	2.4400e-003	1.0000e-005	7.7000e-004	1.0000e-005	7.7000e-004	2.0000e-004	1.0000e-005	2.1000e-004	0.0000	0.6679	0.6679	2.0000e-005	0.0000	0.6684
Total	2.8000e-004	2.1000e-004	2.4400e-003	1.0000e-005	7.7000e-004	1.0000e-005	7.7000e-004	2.0000e-004	1.0000e-005	2.1000e-004	0.0000	0.6679	0.6679	2.0000e-005	0.0000	0.6684

3.5 Building Construction - 2022

Unmitigated Construction On-Site

	ROG	NOx	CO	SO2	Fugitive PM10	Exhaust PM10	PM10 Total	Fugitive PM2.5	Exhaust PM2.5	PM2.5 Total	Bio- CO2	NBio- CO2	Total CO2	CH4	N2O	CO2e
Category	tons/yr										MT/yr					
Off-Road	0.2158	1.9754	2.0700	3.4100e-003		0.1023	0.1023		0.0963	0.0963	0.0000	293.1324	293.1324	0.0702	0.0000	294.8881
Total	0.2158	1.9754	2.0700	3.4100e-003		0.1023	0.1023		0.0963	0.0963	0.0000	293.1324	293.1324	0.0702	0.0000	294.8881

Village South Specific Plan (Proposed) - Los Angeles-South Coast County, Annual

3.5 Building Construction - 2022

Unmitigated Construction Off-Site

	ROG	NOx	CO	SO2	Fugitive PM10	Exhaust PM10	PM10 Total	Fugitive PM2.5	Exhaust PM2.5	PM2.5 Total	Bio- CO2	NBio- CO2	Total CO2	CH4	N2O	CO2e
Category	tons/yr										MT/yr					
Hauling	0.0000	0.0000	0.0000	0.0000	0.0000	0.0000	0.0000	0.0000	0.0000	0.0000	0.0000	0.0000	0.0000	0.0000	0.0000	0.0000
Vendor	0.0527	1.6961	0.4580	4.5500e-003	0.1140	3.1800e-003	0.1171	0.0329	3.0400e-003	0.0359	0.0000	441.9835	441.9835	0.0264	0.0000	442.6435
Worker	0.4088	0.3066	3.5305	0.0107	1.1103	8.8700e-003	1.1192	0.2949	8.1700e-003	0.3031	0.0000	966.8117	966.8117	0.0266	0.0000	967.4773
Total	0.4616	2.0027	3.9885	0.0152	1.2243	0.0121	1.2363	0.3278	0.0112	0.3390	0.0000	1,408.7952	1,408.7952	0.0530	0.0000	1,410.1208

Mitigated Construction On-Site

	ROG	NOx	CO	SO2	Fugitive PM10	Exhaust PM10	PM10 Total	Fugitive PM2.5	Exhaust PM2.5	PM2.5 Total	Bio- CO2	NBio- CO2	Total CO2	CH4	N2O	CO2e
Category	tons/yr										MT/yr					
Off-Road	0.2158	1.9754	2.0700	3.4100e-003		0.1023	0.1023		0.0963	0.0963	0.0000	293.1321	293.1321	0.0702	0.0000	294.8877
Total	0.2158	1.9754	2.0700	3.4100e-003		0.1023	0.1023		0.0963	0.0963	0.0000	293.1321	293.1321	0.0702	0.0000	294.8877

Village South Specific Plan (Proposed) - Los Angeles-South Coast County, Annual

3.5 Building Construction - 2022

Mitigated Construction Off-Site

	ROG	NOx	CO	SO2	Fugitive PM10	Exhaust PM10	PM10 Total	Fugitive PM2.5	Exhaust PM2.5	PM2.5 Total	Bio- CO2	NBio- CO2	Total CO2	CH4	N2O	CO2e
Category	tons/yr										MT/yr					
Hauling	0.0000	0.0000	0.0000	0.0000	0.0000	0.0000	0.0000	0.0000	0.0000	0.0000	0.0000	0.0000	0.0000	0.0000	0.0000	0.0000
Vendor	0.0527	1.6961	0.4580	4.5500e-003	0.1140	3.1800e-003	0.1171	0.0329	3.0400e-003	0.0359	0.0000	441.9835	441.9835	0.0264	0.0000	442.6435
Worker	0.4088	0.3066	3.5305	0.0107	1.1103	8.8700e-003	1.1192	0.2949	8.1700e-003	0.3031	0.0000	966.8117	966.8117	0.0266	0.0000	967.4773
Total	0.4616	2.0027	3.9885	0.0152	1.2243	0.0121	1.2363	0.3278	0.0112	0.3390	0.0000	1,408.7952	1,408.7952	0.0530	0.0000	1,410.1208

3.5 Building Construction - 2023

Unmitigated Construction On-Site

	ROG	NOx	CO	SO2	Fugitive PM10	Exhaust PM10	PM10 Total	Fugitive PM2.5	Exhaust PM2.5	PM2.5 Total	Bio- CO2	NBio- CO2	Total CO2	CH4	N2O	CO2e
Category	tons/yr										MT/yr					
Off-Road	0.1942	1.7765	2.0061	3.3300e-003		0.0864	0.0864		0.0813	0.0813	0.0000	286.2789	286.2789	0.0681	0.0000	287.9814
Total	0.1942	1.7765	2.0061	3.3300e-003		0.0864	0.0864		0.0813	0.0813	0.0000	286.2789	286.2789	0.0681	0.0000	287.9814

Village South Specific Plan (Proposed) - Los Angeles-South Coast County, Annual

3.5 Building Construction - 2023

Unmitigated Construction Off-Site

	ROG	NOx	CO	SO2	Fugitive PM10	Exhaust PM10	PM10 Total	Fugitive PM2.5	Exhaust PM2.5	PM2.5 Total	Bio- CO2	NBio- CO2	Total CO2	CH4	N2O	CO2e
Category	tons/yr										MT/yr					
Hauling	0.0000	0.0000	0.0000	0.0000	0.0000	0.0000	0.0000	0.0000	0.0000	0.0000	0.0000	0.0000	0.0000	0.0000	0.0000	0.0000
Vendor	0.0382	1.2511	0.4011	4.3000e-003	0.1113	1.4600e-003	0.1127	0.0321	1.4000e-003	0.0335	0.0000	417.9930	417.9930	0.0228	0.0000	418.5624
Worker	0.3753	0.2708	3.1696	0.0101	1.0840	8.4100e-003	1.0924	0.2879	7.7400e-003	0.2957	0.0000	909.3439	909.3439	0.0234	0.0000	909.9291
Total	0.4135	1.5218	3.5707	0.0144	1.1953	9.8700e-003	1.2051	0.3200	9.1400e-003	0.3292	0.0000	1,327.3369	1,327.3369	0.0462	0.0000	1,328.4916

Mitigated Construction On-Site

	ROG	NOx	CO	SO2	Fugitive PM10	Exhaust PM10	PM10 Total	Fugitive PM2.5	Exhaust PM2.5	PM2.5 Total	Bio- CO2	NBio- CO2	Total CO2	CH4	N2O	CO2e
Category	tons/yr										MT/yr					
Off-Road	0.1942	1.7765	2.0061	3.3300e-003		0.0864	0.0864		0.0813	0.0813	0.0000	286.2785	286.2785	0.0681	0.0000	287.9811
Total	0.1942	1.7765	2.0061	3.3300e-003		0.0864	0.0864		0.0813	0.0813	0.0000	286.2785	286.2785	0.0681	0.0000	287.9811

Village South Specific Plan (Proposed) - Los Angeles-South Coast County, Annual

3.5 Building Construction - 2023

Mitigated Construction Off-Site

	ROG	NOx	CO	SO2	Fugitive PM10	Exhaust PM10	PM10 Total	Fugitive PM2.5	Exhaust PM2.5	PM2.5 Total	Bio- CO2	NBio- CO2	Total CO2	CH4	N2O	CO2e
Category	tons/yr										MT/yr					
Hauling	0.0000	0.0000	0.0000	0.0000	0.0000	0.0000	0.0000	0.0000	0.0000	0.0000	0.0000	0.0000	0.0000	0.0000	0.0000	0.0000
Vendor	0.0382	1.2511	0.4011	4.3000e-003	0.1113	1.4600e-003	0.1127	0.0321	1.4000e-003	0.0335	0.0000	417.9930	417.9930	0.0228	0.0000	418.5624
Worker	0.3753	0.2708	3.1696	0.0101	1.0840	8.4100e-003	1.0924	0.2879	7.7400e-003	0.2957	0.0000	909.3439	909.3439	0.0234	0.0000	909.9291
Total	0.4135	1.5218	3.5707	0.0144	1.1953	9.8700e-003	1.2051	0.3200	9.1400e-003	0.3292	0.0000	1,327.3369	1,327.3369	0.0462	0.0000	1,328.4916

3.6 Paving - 2023

Unmitigated Construction On-Site

	ROG	NOx	CO	SO2	Fugitive PM10	Exhaust PM10	PM10 Total	Fugitive PM2.5	Exhaust PM2.5	PM2.5 Total	Bio- CO2	NBio- CO2	Total CO2	CH4	N2O	CO2e
Category	tons/yr										MT/yr					
Off-Road	6.7100e-003	0.0663	0.0948	1.5000e-004		3.3200e-003	3.3200e-003		3.0500e-003	3.0500e-003	0.0000	13.0175	13.0175	4.2100e-003	0.0000	13.1227
Paving	0.0000					0.0000	0.0000		0.0000	0.0000	0.0000	0.0000	0.0000	0.0000	0.0000	0.0000
Total	6.7100e-003	0.0663	0.0948	1.5000e-004		3.3200e-003	3.3200e-003		3.0500e-003	3.0500e-003	0.0000	13.0175	13.0175	4.2100e-003	0.0000	13.1227

Village South Specific Plan (Proposed) - Los Angeles-South Coast County, Annual

3.6 Paving - 2023

Unmitigated Construction Off-Site

	ROG	NOx	CO	SO2	Fugitive PM10	Exhaust PM10	PM10 Total	Fugitive PM2.5	Exhaust PM2.5	PM2.5 Total	Bio- CO2	NBio- CO2	Total CO2	CH4	N2O	CO2e
Category	tons/yr										MT/yr					
Hauling	0.0000	0.0000	0.0000	0.0000	0.0000	0.0000	0.0000	0.0000	0.0000	0.0000	0.0000	0.0000	0.0000	0.0000	0.0000	0.0000
Vendor	0.0000	0.0000	0.0000	0.0000	0.0000	0.0000	0.0000	0.0000	0.0000	0.0000	0.0000	0.0000	0.0000	0.0000	0.0000	0.0000
Worker	3.7000e-004	2.7000e-004	3.1200e-003	1.0000e-005	1.0700e-003	1.0000e-005	1.0800e-003	2.8000e-004	1.0000e-005	2.9000e-004	0.0000	0.8963	0.8963	2.0000e-005	0.0000	0.8968
Total	3.7000e-004	2.7000e-004	3.1200e-003	1.0000e-005	1.0700e-003	1.0000e-005	1.0800e-003	2.8000e-004	1.0000e-005	2.9000e-004	0.0000	0.8963	0.8963	2.0000e-005	0.0000	0.8968

Mitigated Construction On-Site

	ROG	NOx	CO	SO2	Fugitive PM10	Exhaust PM10	PM10 Total	Fugitive PM2.5	Exhaust PM2.5	PM2.5 Total	Bio- CO2	NBio- CO2	Total CO2	CH4	N2O	CO2e
Category	tons/yr										MT/yr					
Off-Road	6.7100e-003	0.0663	0.0948	1.5000e-004		3.3200e-003	3.3200e-003		3.0500e-003	3.0500e-003	0.0000	13.0175	13.0175	4.2100e-003	0.0000	13.1227
Paving	0.0000					0.0000	0.0000		0.0000	0.0000	0.0000	0.0000	0.0000	0.0000	0.0000	0.0000
Total	6.7100e-003	0.0663	0.0948	1.5000e-004		3.3200e-003	3.3200e-003		3.0500e-003	3.0500e-003	0.0000	13.0175	13.0175	4.2100e-003	0.0000	13.1227

Village South Specific Plan (Proposed) - Los Angeles-South Coast County, Annual

3.6 Paving - 2023

Mitigated Construction Off-Site

	ROG	NOx	CO	SO2	Fugitive PM10	Exhaust PM10	PM10 Total	Fugitive PM2.5	Exhaust PM2.5	PM2.5 Total	Bio- CO2	NBio- CO2	Total CO2	CH4	N2O	CO2e
Category	tons/yr										MT/yr					
Hauling	0.0000	0.0000	0.0000	0.0000	0.0000	0.0000	0.0000	0.0000	0.0000	0.0000	0.0000	0.0000	0.0000	0.0000	0.0000	0.0000
Vendor	0.0000	0.0000	0.0000	0.0000	0.0000	0.0000	0.0000	0.0000	0.0000	0.0000	0.0000	0.0000	0.0000	0.0000	0.0000	0.0000
Worker	3.7000e-004	2.7000e-004	3.1200e-003	1.0000e-005	1.0700e-003	1.0000e-005	1.0800e-003	2.8000e-004	1.0000e-005	2.9000e-004	0.0000	0.8963	0.8963	2.0000e-005	0.0000	0.8968
Total	3.7000e-004	2.7000e-004	3.1200e-003	1.0000e-005	1.0700e-003	1.0000e-005	1.0800e-003	2.8000e-004	1.0000e-005	2.9000e-004	0.0000	0.8963	0.8963	2.0000e-005	0.0000	0.8968

3.6 Paving - 2024

Unmitigated Construction On-Site

	ROG	NOx	CO	SO2	Fugitive PM10	Exhaust PM10	PM10 Total	Fugitive PM2.5	Exhaust PM2.5	PM2.5 Total	Bio- CO2	NBio- CO2	Total CO2	CH4	N2O	CO2e
Category	tons/yr										MT/yr					
Off-Road	0.0109	0.1048	0.1609	2.5000e-004		5.1500e-003	5.1500e-003		4.7400e-003	4.7400e-003	0.0000	22.0292	22.0292	7.1200e-003	0.0000	22.2073
Paving	0.0000					0.0000	0.0000		0.0000	0.0000	0.0000	0.0000	0.0000	0.0000	0.0000	0.0000
Total	0.0109	0.1048	0.1609	2.5000e-004		5.1500e-003	5.1500e-003		4.7400e-003	4.7400e-003	0.0000	22.0292	22.0292	7.1200e-003	0.0000	22.2073

Village South Specific Plan (Proposed) - Los Angeles-South Coast County, Annual

3.6 Paving - 2024

Unmitigated Construction Off-Site

	ROG	NOx	CO	SO2	Fugitive PM10	Exhaust PM10	PM10 Total	Fugitive PM2.5	Exhaust PM2.5	PM2.5 Total	Bio- CO2	NBio- CO2	Total CO2	CH4	N2O	CO2e
Category	tons/yr										MT/yr					
Hauling	0.0000	0.0000	0.0000	0.0000	0.0000	0.0000	0.0000	0.0000	0.0000	0.0000	0.0000	0.0000	0.0000	0.0000	0.0000	0.0000
Vendor	0.0000	0.0000	0.0000	0.0000	0.0000	0.0000	0.0000	0.0000	0.0000	0.0000	0.0000	0.0000	0.0000	0.0000	0.0000	0.0000
Worker	5.9000e-004	4.1000e-004	4.9200e-003	2.0000e-005	1.8100e-003	1.0000e-005	1.8200e-003	4.8000e-004	1.0000e-005	4.9000e-004	0.0000	1.4697	1.4697	4.0000e-005	0.0000	1.4706
Total	5.9000e-004	4.1000e-004	4.9200e-003	2.0000e-005	1.8100e-003	1.0000e-005	1.8200e-003	4.8000e-004	1.0000e-005	4.9000e-004	0.0000	1.4697	1.4697	4.0000e-005	0.0000	1.4706

Mitigated Construction On-Site

	ROG	NOx	CO	SO2	Fugitive PM10	Exhaust PM10	PM10 Total	Fugitive PM2.5	Exhaust PM2.5	PM2.5 Total	Bio- CO2	NBio- CO2	Total CO2	CH4	N2O	CO2e
Category	tons/yr										MT/yr					
Off-Road	0.0109	0.1048	0.1609	2.5000e-004		5.1500e-003	5.1500e-003		4.7400e-003	4.7400e-003	0.0000	22.0292	22.0292	7.1200e-003	0.0000	22.2073
Paving	0.0000					0.0000	0.0000		0.0000	0.0000	0.0000	0.0000	0.0000	0.0000	0.0000	0.0000
Total	0.0109	0.1048	0.1609	2.5000e-004		5.1500e-003	5.1500e-003		4.7400e-003	4.7400e-003	0.0000	22.0292	22.0292	7.1200e-003	0.0000	22.2073

Village South Specific Plan (Proposed) - Los Angeles-South Coast County, Annual

3.6 Paving - 2024

Mitigated Construction Off-Site

	ROG	NOx	CO	SO2	Fugitive PM10	Exhaust PM10	PM10 Total	Fugitive PM2.5	Exhaust PM2.5	PM2.5 Total	Bio- CO2	NBio- CO2	Total CO2	CH4	N2O	CO2e
Category	tons/yr										MT/yr					
Hauling	0.0000	0.0000	0.0000	0.0000	0.0000	0.0000	0.0000	0.0000	0.0000	0.0000	0.0000	0.0000	0.0000	0.0000	0.0000	0.0000
Vendor	0.0000	0.0000	0.0000	0.0000	0.0000	0.0000	0.0000	0.0000	0.0000	0.0000	0.0000	0.0000	0.0000	0.0000	0.0000	0.0000
Worker	5.9000e-004	4.1000e-004	4.9200e-003	2.0000e-005	1.8100e-003	1.0000e-005	1.8200e-003	4.8000e-004	1.0000e-005	4.9000e-004	0.0000	1.4697	1.4697	4.0000e-005	0.0000	1.4706
Total	5.9000e-004	4.1000e-004	4.9200e-003	2.0000e-005	1.8100e-003	1.0000e-005	1.8200e-003	4.8000e-004	1.0000e-005	4.9000e-004	0.0000	1.4697	1.4697	4.0000e-005	0.0000	1.4706

3.7 Architectural Coating - 2024

Unmitigated Construction On-Site

	ROG	NOx	CO	SO2	Fugitive PM10	Exhaust PM10	PM10 Total	Fugitive PM2.5	Exhaust PM2.5	PM2.5 Total	Bio- CO2	NBio- CO2	Total CO2	CH4	N2O	CO2e
Category	tons/yr										MT/yr					
Archit. Coating	4.1372					0.0000	0.0000		0.0000	0.0000	0.0000	0.0000	0.0000	0.0000	0.0000	0.0000
Off-Road	3.1600e-003	0.0213	0.0317	5.0000e-005		1.0700e-003	1.0700e-003		1.0700e-003	1.0700e-003	0.0000	4.4682	4.4682	2.5000e-004	0.0000	4.4745
Total	4.1404	0.0213	0.0317	5.0000e-005		1.0700e-003	1.0700e-003		1.0700e-003	1.0700e-003	0.0000	4.4682	4.4682	2.5000e-004	0.0000	4.4745

Village South Specific Plan (Proposed) - Los Angeles-South Coast County, Annual

3.7 Architectural Coating - 2024

Unmitigated Construction Off-Site

	ROG	NOx	CO	SO2	Fugitive PM10	Exhaust PM10	PM10 Total	Fugitive PM2.5	Exhaust PM2.5	PM2.5 Total	Bio- CO2	NBio- CO2	Total CO2	CH4	N2O	CO2e
Category	tons/yr										MT/yr					
Hauling	0.0000	0.0000	0.0000	0.0000	0.0000	0.0000	0.0000	0.0000	0.0000	0.0000	0.0000	0.0000	0.0000	0.0000	0.0000	0.0000
Vendor	0.0000	0.0000	0.0000	0.0000	0.0000	0.0000	0.0000	0.0000	0.0000	0.0000	0.0000	0.0000	0.0000	0.0000	0.0000	0.0000
Worker	0.0101	6.9900e-003	0.0835	2.8000e-004	0.0307	2.3000e-004	0.0309	8.1500e-003	2.2000e-004	8.3700e-003	0.0000	24.9407	24.9407	6.1000e-004	0.0000	24.9558
Total	0.0101	6.9900e-003	0.0835	2.8000e-004	0.0307	2.3000e-004	0.0309	8.1500e-003	2.2000e-004	8.3700e-003	0.0000	24.9407	24.9407	6.1000e-004	0.0000	24.9558

Mitigated Construction On-Site

	ROG	NOx	CO	SO2	Fugitive PM10	Exhaust PM10	PM10 Total	Fugitive PM2.5	Exhaust PM2.5	PM2.5 Total	Bio- CO2	NBio- CO2	Total CO2	CH4	N2O	CO2e
Category	tons/yr										MT/yr					
Archit. Coating	4.1372					0.0000	0.0000		0.0000	0.0000	0.0000	0.0000	0.0000	0.0000	0.0000	0.0000
Off-Road	3.1600e-003	0.0213	0.0317	5.0000e-005		1.0700e-003	1.0700e-003		1.0700e-003	1.0700e-003	0.0000	4.4682	4.4682	2.5000e-004	0.0000	4.4745
Total	4.1404	0.0213	0.0317	5.0000e-005		1.0700e-003	1.0700e-003		1.0700e-003	1.0700e-003	0.0000	4.4682	4.4682	2.5000e-004	0.0000	4.4745

Village South Specific Plan (Proposed) - Los Angeles-South Coast County, Annual

3.7 Architectural Coating - 2024

Mitigated Construction Off-Site

	ROG	NOx	CO	SO2	Fugitive PM10	Exhaust PM10	PM10 Total	Fugitive PM2.5	Exhaust PM2.5	PM2.5 Total	Bio- CO2	NBio- CO2	Total CO2	CH4	N2O	CO2e
Category	tons/yr										MT/yr					
Hauling	0.0000	0.0000	0.0000	0.0000	0.0000	0.0000	0.0000	0.0000	0.0000	0.0000	0.0000	0.0000	0.0000	0.0000	0.0000	0.0000
Vendor	0.0000	0.0000	0.0000	0.0000	0.0000	0.0000	0.0000	0.0000	0.0000	0.0000	0.0000	0.0000	0.0000	0.0000	0.0000	0.0000
Worker	0.0101	6.9900e-003	0.0835	2.8000e-004	0.0307	2.3000e-004	0.0309	8.1500e-003	2.2000e-004	8.3700e-003	0.0000	24.9407	24.9407	6.1000e-004	0.0000	24.9558
Total	0.0101	6.9900e-003	0.0835	2.8000e-004	0.0307	2.3000e-004	0.0309	8.1500e-003	2.2000e-004	8.3700e-003	0.0000	24.9407	24.9407	6.1000e-004	0.0000	24.9558

4.0 Operational Detail - Mobile

4.1 Mitigation Measures Mobile

Village South Specific Plan (Proposed) - Los Angeles-South Coast County, Annual

	ROG	NOx	CO	SO2	Fugitive PM10	Exhaust PM10	PM10 Total	Fugitive PM2.5	Exhaust PM2.5	PM2.5 Total	Bio- CO2	NBio- CO2	Total CO2	CH4	N2O	CO2e
Category	tons/yr										MT/yr					
Mitigated	1.5857	7.9962	19.1834	0.0821	7.7979	0.0580	7.8559	2.0895	0.0539	2.1434	0.0000	7,620.4986	7,620.4986	0.3407	0.0000	7,629.0162
Unmitigated	1.5857	7.9962	19.1834	0.0821	7.7979	0.0580	7.8559	2.0895	0.0539	2.1434	0.0000	7,620.4986	7,620.4986	0.3407	0.0000	7,629.0162

4.2 Trip Summary Information

Land Use	Average Daily Trip Rate			Unmitigated	Mitigated
	Weekday	Saturday	Sunday	Annual VMT	Annual VMT
Apartments Low Rise	145.75	154.25	154.00	506,227	506,227
Apartments Mid Rise	4,026.75	3,773.25	4075.50	13,660,065	13,660,065
General Office Building	288.45	62.55	31.05	706,812	706,812
High Turnover (Sit Down Restaurant)	2,368.80	2,873.52	2817.72	3,413,937	3,413,937
Hotel	192.00	187.50	160.00	445,703	445,703
Quality Restaurant	501.12	511.92	461.20	707,488	707,488
Regional Shopping Center	528.08	601.44	357.84	1,112,221	1,112,221
Total	8,050.95	8,164.43	8,057.31	20,552,452	20,552,452

4.3 Trip Type Information

Village South Specific Plan (Proposed) - Los Angeles-South Coast County, Annual

Land Use	Miles			Trip %			Trip Purpose %		
	H-W or C-W	H-S or C-C	H-O or C-NW	H-W or C-W	H-S or C-C	H-O or C-NW	Primary	Diverted	Pass-by
Apartments Low Rise	14.70	5.90	8.70	40.20	19.20	40.60	86	11	3
Apartments Mid Rise	14.70	5.90	8.70	40.20	19.20	40.60	86	11	3
General Office Building	16.60	8.40	6.90	33.00	48.00	19.00	77	19	4
High Turnover (Sit Down Restaurant)	16.60	8.40	6.90	8.50	72.50	19.00	37	20	43
Hotel	16.60	8.40	6.90	19.40	61.60	19.00	58	38	4
Quality Restaurant	16.60	8.40	6.90	12.00	69.00	19.00	38	18	44
Regional Shopping Center	16.60	8.40	6.90	16.30	64.70	19.00	54	35	11

4.4 Fleet Mix

Land Use	LDA	LDT1	LDT2	MDV	LHD1	LHD2	MHD	HHD	OBUS	UBUS	MCY	SBUS	MH
Apartments Low Rise	0.543088	0.044216	0.209971	0.116369	0.014033	0.006332	0.021166	0.033577	0.002613	0.001817	0.005285	0.000712	0.000821
Apartments Mid Rise	0.543088	0.044216	0.209971	0.116369	0.014033	0.006332	0.021166	0.033577	0.002613	0.001817	0.005285	0.000712	0.000821
General Office Building	0.543088	0.044216	0.209971	0.116369	0.014033	0.006332	0.021166	0.033577	0.002613	0.001817	0.005285	0.000712	0.000821
High Turnover (Sit Down Restaurant)	0.543088	0.044216	0.209971	0.116369	0.014033	0.006332	0.021166	0.033577	0.002613	0.001817	0.005285	0.000712	0.000821
Hotel	0.543088	0.044216	0.209971	0.116369	0.014033	0.006332	0.021166	0.033577	0.002613	0.001817	0.005285	0.000712	0.000821
Quality Restaurant	0.543088	0.044216	0.209971	0.116369	0.014033	0.006332	0.021166	0.033577	0.002613	0.001817	0.005285	0.000712	0.000821
Regional Shopping Center	0.543088	0.044216	0.209971	0.116369	0.014033	0.006332	0.021166	0.033577	0.002613	0.001817	0.005285	0.000712	0.000821

5.0 Energy Detail

Historical Energy Use: N

5.1 Mitigation Measures Energy

Village South Specific Plan (Proposed) - Los Angeles-South Coast County, Annual

	ROG	NOx	CO	SO2	Fugitive PM10	Exhaust PM10	PM10 Total	Fugitive PM2.5	Exhaust PM2.5	PM2.5 Total	Bio- CO2	NBio- CO2	Total CO2	CH4	N2O	CO2e
Category	tons/yr										MT/yr					
Electricity Mitigated							0.0000	0.0000		0.0000	0.0000	2,512.6465	2,512.6465	0.1037	0.0215	2,521.6356
Electricity Unmitigated							0.0000	0.0000		0.0000	0.0000	2,512.6465	2,512.6465	0.1037	0.0215	2,521.6356
NaturalGas Mitigated	0.1398	1.2312	0.7770	7.6200e-003			0.0966	0.0966		0.0966	0.0966	1,383.4267	1,383.4267	0.0265	0.0254	1,391.6478
NaturalGas Unmitigated	0.1398	1.2312	0.7770	7.6200e-003			0.0966	0.0966		0.0966	0.0966	1,383.4267	1,383.4267	0.0265	0.0254	1,391.6478

Village South Specific Plan (Proposed) - Los Angeles-South Coast County, Annual

5.2 Energy by Land Use - NaturalGas

Unmitigated

	NaturalGas Use	ROG	NOx	CO	SO2	Fugitive PM10	Exhaust PM10	PM10 Total	Fugitive PM2.5	Exhaust PM2.5	PM2.5 Total	Bio- CO2	NBio- CO2	Total CO2	CH4	N2O	CO2e
Land Use	kBTU/yr	tons/yr										MT/yr					
Apartments Low Rise	408494	2.2000e-003	0.0188	8.0100e-003	1.2000e-004		1.5200e-003	1.5200e-003		1.5200e-003	1.5200e-003	0.0000	21.7988	21.7988	4.2000e-004	4.0000e-004	21.9284
Apartments Mid Rise	1.30613e+007	0.0704	0.6018	0.2561	3.8400e-003		0.0487	0.0487		0.0487	0.0487	0.0000	696.9989	696.9989	0.0134	0.0128	701.1408
General Office Building	468450	2.5300e-003	0.0230	0.0193	1.4000e-004		1.7500e-003	1.7500e-003		1.7500e-003	1.7500e-003	0.0000	24.9983	24.9983	4.8000e-004	4.6000e-004	25.1468
High Turnover (Sit Down Restaurant)	8.30736e+006	0.0448	0.4072	0.3421	2.4400e-003		0.0310	0.0310		0.0310	0.0310	0.0000	443.3124	443.3124	8.5000e-003	8.1300e-003	445.9468
Hotel	1.74095e+006	9.3900e-003	0.0853	0.0717	5.1000e-004		6.4900e-003	6.4900e-003		6.4900e-003	6.4900e-003	0.0000	92.9036	92.9036	1.7800e-003	1.7000e-003	93.4557
Quality Restaurant	1.84608e+006	9.9500e-003	0.0905	0.0760	5.4000e-004		6.8800e-003	6.8800e-003		6.8800e-003	6.8800e-003	0.0000	98.5139	98.5139	1.8900e-003	1.8100e-003	99.0993
Regional Shopping Center	91840	5.0000e-004	4.5000e-003	3.7800e-003	3.0000e-005		3.4000e-004	3.4000e-004		3.4000e-004	3.4000e-004	0.0000	4.9009	4.9009	9.0000e-005	9.0000e-005	4.9301
Total		0.1398	1.2312	0.7770	7.6200e-003		0.0966	0.0966		0.0966	0.0966	0.0000	1,383.4268	1,383.4268	0.0265	0.0254	1,391.6478

Village South Specific Plan (Proposed) - Los Angeles-South Coast County, Annual

5.2 Energy by Land Use - NaturalGas

Mitigated

	NaturalGas Use	ROG	NOx	CO	SO2	Fugitive PM10	Exhaust PM10	PM10 Total	Fugitive PM2.5	Exhaust PM2.5	PM2.5 Total	Bio- CO2	NBio- CO2	Total CO2	CH4	N2O	CO2e
Land Use	kBTU/yr	tons/yr										MT/yr					
Apartments Low Rise	408494	2.2000e-003	0.0188	8.0100e-003	1.2000e-004		1.5200e-003	1.5200e-003		1.5200e-003	1.5200e-003	0.0000	21.7988	21.7988	4.2000e-004	4.0000e-004	21.9284
Apartments Mid Rise	1.30613e+007	0.0704	0.6018	0.2561	3.8400e-003		0.0487	0.0487		0.0487	0.0487	0.0000	696.9989	696.9989	0.0134	0.0128	701.1408
General Office Building	468450	2.5300e-003	0.0230	0.0193	1.4000e-004		1.7500e-003	1.7500e-003		1.7500e-003	1.7500e-003	0.0000	24.9983	24.9983	4.8000e-004	4.6000e-004	25.1468
High Turnover (Sit Down Restaurant)	8.30736e+006	0.0448	0.4072	0.3421	2.4400e-003		0.0310	0.0310		0.0310	0.0310	0.0000	443.3124	443.3124	8.5000e-003	8.1300e-003	445.9468
Hotel	1.74095e+006	9.3900e-003	0.0853	0.0717	5.1000e-004		6.4900e-003	6.4900e-003		6.4900e-003	6.4900e-003	0.0000	92.9036	92.9036	1.7800e-003	1.7000e-003	93.4557
Quality Restaurant	1.84608e+006	9.9500e-003	0.0905	0.0760	5.4000e-004		6.8800e-003	6.8800e-003		6.8800e-003	6.8800e-003	0.0000	98.5139	98.5139	1.8900e-003	1.8100e-003	99.0993
Regional Shopping Center	91840	5.0000e-004	4.5000e-003	3.7800e-003	3.0000e-005		3.4000e-004	3.4000e-004		3.4000e-004	3.4000e-004	0.0000	4.9009	4.9009	9.0000e-005	9.0000e-005	4.9301
Total		0.1398	1.2312	0.7770	7.6200e-003		0.0966	0.0966		0.0966	0.0966	0.0000	1,383.4268	1,383.4268	0.0265	0.0254	1,391.6478

Village South Specific Plan (Proposed) - Los Angeles-South Coast County, Annual

5.3 Energy by Land Use - Electricity

Unmitigated

	Electricity Use	Total CO2	CH4	N2O	CO2e
Land Use	kWh/yr	MT/yr			
Apartments Low Rise	106010	33.7770	1.3900e-003	2.9000e-004	33.8978
Apartments Mid Rise	3.94697e+006	1,257.5879	0.0519	0.0107	1,262.0869
General Office Building	584550	186.2502	7.6900e-003	1.5900e-003	186.9165
High Turnover (Sit Down Restaurant)	1.58904e+006	506.3022	0.0209	4.3200e-003	508.1135
Hotel	550308	175.3399	7.2400e-003	1.5000e-003	175.9672
Quality Restaurant	353120	112.5116	4.6500e-003	9.6000e-004	112.9141
Regional Shopping Center	756000	240.8778	9.9400e-003	2.0600e-003	241.7395
Total		2,512.6465	0.1037	0.0215	2,521.6356

Village South Specific Plan (Proposed) - Los Angeles-South Coast County, Annual

5.3 Energy by Land Use - Electricity

Mitigated

	Electricity Use	Total CO2	CH4	N2O	CO2e
Land Use	kWh/yr	MT/yr			
Apartments Low Rise	106010	33.7770	1.3900e-003	2.9000e-004	33.8978
Apartments Mid Rise	3.94697e+006	1,257.5879	0.0519	0.0107	1,262.0869
General Office Building	584550	186.2502	7.6900e-003	1.5900e-003	186.9165
High Turnover (Sit Down Restaurant)	1.58904e+006	506.3022	0.0209	4.3200e-003	508.1135
Hotel	550308	175.3399	7.2400e-003	1.5000e-003	175.9672
Quality Restaurant	353120	112.5116	4.6500e-003	9.6000e-004	112.9141
Regional Shopping Center	756000	240.8778	9.9400e-003	2.0600e-003	241.7395
Total		2,512.6465	0.1037	0.0215	2,521.6356

6.0 Area Detail

6.1 Mitigation Measures Area

Village South Specific Plan (Proposed) - Los Angeles-South Coast County, Annual

	ROG	NOx	CO	SO2	Fugitive PM10	Exhaust PM10	PM10 Total	Fugitive PM2.5	Exhaust PM2.5	PM2.5 Total	Bio- CO2	NBio- CO2	Total CO2	CH4	N2O	CO2e
Category	tons/yr										MT/yr					
Mitigated	5.1437	0.2950	10.3804	1.6700e-003		0.0714	0.0714		0.0714	0.0714	0.0000	220.9670	220.9670	0.0201	3.7400e-003	222.5835
Unmitigated	5.1437	0.2950	10.3804	1.6700e-003		0.0714	0.0714		0.0714	0.0714	0.0000	220.9670	220.9670	0.0201	3.7400e-003	222.5835

6.2 Area by SubCategory

Unmitigated

	ROG	NOx	CO	SO2	Fugitive PM10	Exhaust PM10	PM10 Total	Fugitive PM2.5	Exhaust PM2.5	PM2.5 Total	Bio- CO2	NBio- CO2	Total CO2	CH4	N2O	CO2e
SubCategory	tons/yr										MT/yr					
Architectural Coating	0.4137					0.0000	0.0000		0.0000	0.0000	0.0000	0.0000	0.0000	0.0000	0.0000	0.0000
Consumer Products	4.3998					0.0000	0.0000		0.0000	0.0000	0.0000	0.0000	0.0000	0.0000	0.0000	0.0000
Hearth	0.0206	0.1763	0.0750	1.1200e-003		0.0143	0.0143		0.0143	0.0143	0.0000	204.1166	204.1166	3.9100e-003	3.7400e-003	205.3295
Landscaping	0.3096	0.1187	10.3054	5.4000e-004		0.0572	0.0572		0.0572	0.0572	0.0000	16.8504	16.8504	0.0161	0.0000	17.2540
Total	5.1437	0.2950	10.3804	1.6600e-003		0.0714	0.0714		0.0714	0.0714	0.0000	220.9670	220.9670	0.0201	3.7400e-003	222.5835

Village South Specific Plan (Proposed) - Los Angeles-South Coast County, Annual

6.2 Area by SubCategory

Mitigated

	ROG	NOx	CO	SO2	Fugitive PM10	Exhaust PM10	PM10 Total	Fugitive PM2.5	Exhaust PM2.5	PM2.5 Total	Bio- CO2	NBio- CO2	Total CO2	CH4	N2O	CO2e
SubCategory	tons/yr										MT/yr					
Architectural Coating	0.4137					0.0000	0.0000		0.0000	0.0000	0.0000	0.0000	0.0000	0.0000	0.0000	0.0000
Consumer Products	4.3998					0.0000	0.0000		0.0000	0.0000	0.0000	0.0000	0.0000	0.0000	0.0000	0.0000
Hearth	0.0206	0.1763	0.0750	1.1200e-003		0.0143	0.0143		0.0143	0.0143	0.0000	204.1166	204.1166	3.9100e-003	3.7400e-003	205.3295
Landscaping	0.3096	0.1187	10.3054	5.4000e-004		0.0572	0.0572		0.0572	0.0572	0.0000	16.8504	16.8504	0.0161	0.0000	17.2540
Total	5.1437	0.2950	10.3804	1.6600e-003		0.0714	0.0714		0.0714	0.0714	0.0000	220.9670	220.9670	0.0201	3.7400e-003	222.5835

7.0 Water Detail

7.1 Mitigation Measures Water

Village South Specific Plan (Proposed) - Los Angeles-South Coast County, Annual

	Total CO2	CH4	N2O	CO2e
Category	MT/yr			
Mitigated	585.8052	3.0183	0.0755	683.7567
Unmitigated	585.8052	3.0183	0.0755	683.7567

Village South Specific Plan (Proposed) - Los Angeles-South Coast County, Annual

7.2 Water by Land Use

Unmitigated

	Indoor/Outdoor Use	Total CO2	CH4	N2O	CO2e
Land Use	Mgal	MT/yr			
Apartments Low Rise	1.62885 / 1.02688	10.9095	0.0535	1.3400e-003	12.6471
Apartments Mid Rise	63.5252 / 40.0485	425.4719	2.0867	0.0523	493.2363
General Office Building	7.99802 / 4.90201	53.0719	0.2627	6.5900e-003	61.6019
High Turnover (Sit Down Restaurant)	10.9272 / 0.697482	51.2702	0.3580	8.8200e-003	62.8482
Hotel	1.26834 / 0.140927	6.1633	0.0416	1.0300e-003	7.5079
Quality Restaurant	2.42827 / 0.154996	11.3934	0.0796	1.9600e-003	13.9663
Regional Shopping Center	4.14806 / 2.54236	27.5250	0.1363	3.4200e-003	31.9490
Total		585.8052	3.0183	0.0755	683.7567

Village South Specific Plan (Proposed) - Los Angeles-South Coast County, Annual

7.2 Water by Land Use

Mitigated

	Indoor/Outdoor Use	Total CO2	CH4	N2O	CO2e
Land Use	Mgal	MT/yr			
Apartments Low Rise	1.62885 / 1.02688	10.9095	0.0535	1.3400e-003	12.6471
Apartments Mid Rise	63.5252 / 40.0485	425.4719	2.0867	0.0523	493.2363
General Office Building	7.99802 / 4.90201	53.0719	0.2627	6.5900e-003	61.6019
High Turnover (Sit Down Restaurant)	10.9272 / 0.697482	51.2702	0.3580	8.8200e-003	62.8482
Hotel	1.26834 / 0.140927	6.1633	0.0416	1.0300e-003	7.5079
Quality Restaurant	2.42827 / 0.154996	11.3934	0.0796	1.9600e-003	13.9663
Regional Shopping Center	4.14806 / 2.54236	27.5250	0.1363	3.4200e-003	31.9490
Total		585.8052	3.0183	0.0755	683.7567

8.0 Waste Detail

8.1 Mitigation Measures Waste

Village South Specific Plan (Proposed) - Los Angeles-South Coast County, Annual

Category/Year

	Total CO2	CH4	N2O	CO2e
	MT/yr			
Mitigated	207.8079	12.2811	0.0000	514.8354
Unmitigated	207.8079	12.2811	0.0000	514.8354

Village South Specific Plan (Proposed) - Los Angeles-South Coast County, Annual

8.2 Waste by Land Use

Unmitigated

	Waste Disposed	Total CO2	CH4	N2O	CO2e
Land Use	tons	MT/yr			
Apartments Low Rise	11.5	2.3344	0.1380	0.0000	5.7834
Apartments Mid Rise	448.5	91.0415	5.3804	0.0000	225.5513
General Office Building	41.85	8.4952	0.5021	0.0000	21.0464
High Turnover (Sit Down Restaurant)	428.4	86.9613	5.1393	0.0000	215.4430
Hotel	27.38	5.5579	0.3285	0.0000	13.7694
Quality Restaurant	7.3	1.4818	0.0876	0.0000	3.6712
Regional Shopping Center	58.8	11.9359	0.7054	0.0000	29.5706
Total		207.8079	12.2811	0.0000	514.8354

Village South Specific Plan (Proposed) - Los Angeles-South Coast County, Annual

8.2 Waste by Land Use

Mitigated

	Waste Disposed	Total CO2	CH4	N2O	CO2e
Land Use	tons	MT/yr			
Apartments Low Rise	11.5	2.3344	0.1380	0.0000	5.7834
Apartments Mid Rise	448.5	91.0415	5.3804	0.0000	225.5513
General Office Building	41.85	8.4952	0.5021	0.0000	21.0464
High Turnover (Sit Down Restaurant)	428.4	86.9613	5.1393	0.0000	215.4430
Hotel	27.38	5.5579	0.3285	0.0000	13.7694
Quality Restaurant	7.3	1.4818	0.0876	0.0000	3.6712
Regional Shopping Center	58.8	11.9359	0.7054	0.0000	29.5706
Total		207.8079	12.2811	0.0000	514.8354

9.0 Operational Offroad

Equipment Type	Number	Hours/Day	Days/Year	Horse Power	Load Factor	Fuel Type
----------------	--------	-----------	-----------	-------------	-------------	-----------

10.0 Stationary Equipment

Fire Pumps and Emergency Generators

Equipment Type	Number	Hours/Day	Hours/Year	Horse Power	Load Factor	Fuel Type
----------------	--------	-----------	------------	-------------	-------------	-----------

Village South Specific Plan (Proposed) - Los Angeles-South Coast County, Annual

Boilers

Equipment Type	Number	Heat Input/Day	Heat Input/Year	Boiler Rating	Fuel Type
----------------	--------	----------------	-----------------	---------------	-----------

User Defined Equipment

Equipment Type	Number
----------------	--------

11.0 Vegetation

Village South Specific Plan (Proposed) - Los Angeles-South Coast County, Summer

Village South Specific Plan (Proposed)
Los Angeles-South Coast County, Summer

1.0 Project Characteristics

1.1 Land Usage

Land Uses	Size	Metric	Lot Acreage	Floor Surface Area	Population
General Office Building	45.00	1000sqft	1.03	45,000.00	0
High Turnover (Sit Down Restaurant)	36.00	1000sqft	0.83	36,000.00	0
Hotel	50.00	Room	1.67	72,600.00	0
Quality Restaurant	8.00	1000sqft	0.18	8,000.00	0
Apartments Low Rise	25.00	Dwelling Unit	1.56	25,000.00	72
Apartments Mid Rise	975.00	Dwelling Unit	25.66	975,000.00	2789
Regional Shopping Center	56.00	1000sqft	1.29	56,000.00	0

1.2 Other Project Characteristics

Urbanization	Urban	Wind Speed (m/s)	2.2	Precipitation Freq (Days)	33
Climate Zone	9			Operational Year	2028
Utility Company	Southern California Edison				
CO2 Intensity (lb/MWhr)	702.44	CH4 Intensity (lb/MWhr)	0.029	N2O Intensity (lb/MWhr)	0.006

1.3 User Entered Comments & Non-Default Data

Village South Specific Plan (Proposed) - Los Angeles-South Coast County, Summer

Project Characteristics - Consistent with the DEIR's model.

Land Use - See SWAPE comment regarding residential and retail land uses.

Construction Phase - See SWAPE comment regarding individual construction phase lengths.

Demolition - Consistent with the DEIR's model. See SWAPE comment regarding demolition.

Vehicle Trips - Saturday trips consistent with the DEIR's model. See SWAPE comment regarding weekday and Sunday trips.

Woodstoves - Woodstoves and wood-burning fireplaces consistent with the DEIR's model. See SWAPE comment regarding gas fireplaces.

Energy Use -

Construction Off-road Equipment Mitigation - See SWAPE comment on construction-related mitigation.

Area Mitigation - See SWAPE comment regarding operational mitigation measures.

Water Mitigation - See SWAPE comment regarding operational mitigation measures.

Table Name	Column Name	Default Value	New Value
tblFireplaces	FireplaceWoodMass	1,019.20	0.00
tblFireplaces	FireplaceWoodMass	1,019.20	0.00
tblFireplaces	NumberWood	1.25	0.00
tblFireplaces	NumberWood	48.75	0.00
tblVehicleTrips	ST_TR	7.16	6.17
tblVehicleTrips	ST_TR	6.39	3.87
tblVehicleTrips	ST_TR	2.46	1.39
tblVehicleTrips	ST_TR	158.37	79.82
tblVehicleTrips	ST_TR	8.19	3.75
tblVehicleTrips	ST_TR	94.36	63.99
tblVehicleTrips	ST_TR	49.97	10.74
tblVehicleTrips	SU_TR	6.07	6.16
tblVehicleTrips	SU_TR	5.86	4.18
tblVehicleTrips	SU_TR	1.05	0.69
tblVehicleTrips	SU_TR	131.84	78.27

Village South Specific Plan (Proposed) - Los Angeles-South Coast County, Summer

tblVehicleTrips	SU_TR	5.95	3.20
tblVehicleTrips	SU_TR	72.16	57.65
tblVehicleTrips	SU_TR	25.24	6.39
tblVehicleTrips	WD_TR	6.59	5.83
tblVehicleTrips	WD_TR	6.65	4.13
tblVehicleTrips	WD_TR	11.03	6.41
tblVehicleTrips	WD_TR	127.15	65.80
tblVehicleTrips	WD_TR	8.17	3.84
tblVehicleTrips	WD_TR	89.95	62.64
tblVehicleTrips	WD_TR	42.70	9.43
tblWoodstoves	NumberCatalytic	1.25	0.00
tblWoodstoves	NumberCatalytic	48.75	0.00
tblWoodstoves	NumberNoncatalytic	1.25	0.00
tblWoodstoves	NumberNoncatalytic	48.75	0.00
tblWoodstoves	WoodstoveDayYear	25.00	0.00
tblWoodstoves	WoodstoveDayYear	25.00	0.00
tblWoodstoves	WoodstoveWoodMass	999.60	0.00
tblWoodstoves	WoodstoveWoodMass	999.60	0.00

2.0 Emissions Summary

Village South Specific Plan (Proposed) - Los Angeles-South Coast County, Summer

2.1 Overall Construction (Maximum Daily Emission)

Unmitigated Construction

	ROG	NOx	CO	SO2	Fugitive PM10	Exhaust PM10	PM10 Total	Fugitive PM2.5	Exhaust PM2.5	PM2.5 Total	Bio- CO2	NBio- CO2	Total CO2	CH4	N2O	CO2e
Year	lb/day										lb/day					
2021	4.2769	46.4588	31.6840	0.0643	18.2675	2.0461	20.3135	9.9840	1.8824	11.8664	0.0000	6,234.7974	6,234.7974	1.9495	0.0000	6,283.5352
2022	5.3304	38.8967	49.5629	0.1517	9.8688	1.6366	10.7727	3.6558	1.5057	5.1615	0.0000	15,251.5674	15,251.5674	1.9503	0.0000	15,278.5288
2023	4.8957	26.3317	46.7567	0.1472	9.8688	0.7794	10.6482	2.6381	0.7322	3.3702	0.0000	14,807.5269	14,807.5269	1.0250	0.0000	14,833.1521
2024	237.1630	9.5575	15.1043	0.0244	1.7884	0.4698	1.8628	0.4743	0.4322	0.5476	0.0000	2,361.3989	2,361.3989	0.7177	0.0000	2,379.3421
Maximum	237.1630	46.4588	49.5629	0.1517	18.2675	2.0461	20.3135	9.9840	1.8824	11.8664	0.0000	15,251.5674	15,251.5674	1.9503	0.0000	15,278.5288

Village South Specific Plan (Proposed) - Los Angeles-South Coast County, Summer

2.2 Overall Operational

Unmitigated Operational

	ROG	NOx	CO	SO2	Fugitive PM10	Exhaust PM10	PM10 Total	Fugitive PM2.5	Exhaust PM2.5	PM2.5 Total	Bio- CO2	NBio- CO2	Total CO2	CH4	N2O	CO2e
Category	lb/day										lb/day					
Area	30.5020	15.0496	88.4430	0.0944		1.5974	1.5974		1.5974	1.5974	0.0000	18,148.59 50	18,148.59 50	0.4874	0.3300	18,259.11 92
Energy	0.7660	6.7462	4.2573	0.0418		0.5292	0.5292		0.5292	0.5292		8,355.983 2	8,355.983 2	0.1602	0.1532	8,405.638 7
Mobile	9.8489	45.4304	114.8495	0.4917	45.9592	0.3360	46.2951	12.2950	0.3119	12.6070		50,306.60 34	50,306.60 34	2.1807		50,361.12 08
Total	41.1168	67.2262	207.5497	0.6278	45.9592	2.4626	48.4217	12.2950	2.4385	14.7336	0.0000	76,811.18 16	76,811.18 16	2.8282	0.4832	77,025.87 86

Mitigated Operational

	ROG	NOx	CO	SO2	Fugitive PM10	Exhaust PM10	PM10 Total	Fugitive PM2.5	Exhaust PM2.5	PM2.5 Total	Bio- CO2	NBio- CO2	Total CO2	CH4	N2O	CO2e
Category	lb/day										lb/day					
Area	30.5020	15.0496	88.4430	0.0944		1.5974	1.5974		1.5974	1.5974	0.0000	18,148.59 50	18,148.59 50	0.4874	0.3300	18,259.11 92
Energy	0.7660	6.7462	4.2573	0.0418		0.5292	0.5292		0.5292	0.5292		8,355.983 2	8,355.983 2	0.1602	0.1532	8,405.638 7
Mobile	9.8489	45.4304	114.8495	0.4917	45.9592	0.3360	46.2951	12.2950	0.3119	12.6070		50,306.60 34	50,306.60 34	2.1807		50,361.12 08
Total	41.1168	67.2262	207.5497	0.6278	45.9592	2.4626	48.4217	12.2950	2.4385	14.7336	0.0000	76,811.18 16	76,811.18 16	2.8282	0.4832	77,025.87 86

Village South Specific Plan (Proposed) - Los Angeles-South Coast County, Summer

	ROG	NOx	CO	SO2	Fugitive PM10	Exhaust PM10	PM10 Total	Fugitive PM2.5	Exhaust PM2.5	PM2.5 Total	Bio- CO2	NBio-CO2	Total CO2	CH4	N2O	CO2e
Percent Reduction	0.00	0.00	0.00	0.00	0.00	0.00	0.00	0.00	0.00	0.00	0.00	0.00	0.00	0.00	0.00	0.00

3.0 Construction Detail

Construction Phase

Phase Number	Phase Name	Phase Type	Start Date	End Date	Num Days Week	Num Days	Phase Description
1	Demolition	Demolition	9/1/2021	10/12/2021	5	30	
2	Site Preparation	Site Preparation	10/13/2021	11/9/2021	5	20	
3	Grading	Grading	11/10/2021	1/11/2022	5	45	
4	Building Construction	Building Construction	1/12/2022	12/12/2023	5	500	
5	Paving	Paving	12/13/2023	1/30/2024	5	35	
6	Architectural Coating	Architectural Coating	1/31/2024	3/19/2024	5	35	

Acres of Grading (Site Preparation Phase): 0

Acres of Grading (Grading Phase): 112.5

Acres of Paving: 0

Residential Indoor: 2,025,000; Residential Outdoor: 675,000; Non-Residential Indoor: 326,400; Non-Residential Outdoor: 108,800; Striped Parking Area: 0 (Architectural Coating – sqft)

OffRoad Equipment

Village South Specific Plan (Proposed) - Los Angeles-South Coast County, Summer

Phase Name	Offroad Equipment Type	Amount	Usage Hours	Horse Power	Load Factor
Demolition	Concrete/Industrial Saws	1	8.00	81	0.73
Demolition	Excavators	3	8.00	158	0.38
Demolition	Rubber Tired Dozers	2	8.00	247	0.40
Site Preparation	Rubber Tired Dozers	3	8.00	247	0.40
Site Preparation	Tractors/Loaders/Backhoes	4	8.00	97	0.37
Grading	Excavators	2	8.00	158	0.38
Grading	Graders	1	8.00	187	0.41
Grading	Rubber Tired Dozers	1	8.00	247	0.40
Grading	Scrapers	2	8.00	367	0.48
Grading	Tractors/Loaders/Backhoes	2	8.00	97	0.37
Building Construction	Cranes	1	7.00	231	0.29
Building Construction	Forklifts	3	8.00	89	0.20
Building Construction	Generator Sets	1	8.00	84	0.74
Building Construction	Tractors/Loaders/Backhoes	3	7.00	97	0.37
Building Construction	Welders	1	8.00	46	0.45
Paving	Pavers	2	8.00	130	0.42
Paving	Paving Equipment	2	8.00	132	0.36
Paving	Rollers	2	8.00	80	0.38
Architectural Coating	Air Compressors	1	6.00	78	0.48

Trips and VMT

Village South Specific Plan (Proposed) - Los Angeles-South Coast County, Summer

Phase Name	Offroad Equipment Count	Worker Trip Number	Vendor Trip Number	Hauling Trip Number	Worker Trip Length	Vendor Trip Length	Hauling Trip Length	Worker Vehicle Class	Vendor Vehicle Class	Hauling Vehicle Class
Demolition	6	15.00	0.00	458.00	14.70	6.90	20.00	LD_Mix	HDT_Mix	HHDT
Site Preparation	7	18.00	0.00	0.00	14.70	6.90	20.00	LD_Mix	HDT_Mix	HHDT
Grading	8	20.00	0.00	0.00	14.70	6.90	20.00	LD_Mix	HDT_Mix	HHDT
Building Construction	9	801.00	143.00	0.00	14.70	6.90	20.00	LD_Mix	HDT_Mix	HHDT
Paving	6	15.00	0.00	0.00	14.70	6.90	20.00	LD_Mix	HDT_Mix	HHDT
Architectural Coating	1	160.00	0.00	0.00	14.70	6.90	20.00	LD_Mix	HDT_Mix	HHDT

3.1 Mitigation Measures Construction

3.2 Demolition - 2021

Unmitigated Construction On-Site

	ROG	NOx	CO	SO2	Fugitive PM10	Exhaust PM10	PM10 Total	Fugitive PM2.5	Exhaust PM2.5	PM2.5 Total	Bio- CO2	NBio- CO2	Total CO2	CH4	N2O	CO2e
Category	lb/day										lb/day					
Fugitive Dust					3.3074	0.0000	3.3074	0.5008	0.0000	0.5008			0.0000			0.0000
Off-Road	3.1651	31.4407	21.5650	0.0388		1.5513	1.5513		1.4411	1.4411		3,747.9449	3,747.9449	1.0549		3,774.3174
Total	3.1651	31.4407	21.5650	0.0388	3.3074	1.5513	4.8588	0.5008	1.4411	1.9419		3,747.9449	3,747.9449	1.0549		3,774.3174

Village South Specific Plan (Proposed) - Los Angeles-South Coast County, Summer

3.2 Demolition - 2021

Unmitigated Construction Off-Site

	ROG	NOx	CO	SO2	Fugitive PM10	Exhaust PM10	PM10 Total	Fugitive PM2.5	Exhaust PM2.5	PM2.5 Total	Bio- CO2	NBio- CO2	Total CO2	CH4	N2O	CO2e
Category	lb/day										lb/day					
Hauling	0.1273	4.0952	0.9602	0.0119	0.2669	0.0126	0.2795	0.0732	0.0120	0.0852		1,292.2413	1,292.2413	0.0877		1,294.4337
Vendor	0.0000	0.0000	0.0000	0.0000	0.0000	0.0000	0.0000	0.0000	0.0000	0.0000		0.0000	0.0000	0.0000		0.0000
Worker	0.0643	0.0442	0.6042	1.7100e-003	0.1677	1.3500e-003	0.1690	0.0445	1.2500e-003	0.0457		170.8155	170.8155	5.0300e-003		170.9413
Total	0.1916	4.1394	1.5644	0.0136	0.4346	0.0139	0.4485	0.1176	0.0133	0.1309		1,463.0568	1,463.0568	0.0927		1,465.3750

Mitigated Construction On-Site

	ROG	NOx	CO	SO2	Fugitive PM10	Exhaust PM10	PM10 Total	Fugitive PM2.5	Exhaust PM2.5	PM2.5 Total	Bio- CO2	NBio- CO2	Total CO2	CH4	N2O	CO2e
Category	lb/day										lb/day					
Fugitive Dust					3.3074	0.0000	3.3074	0.5008	0.0000	0.5008			0.0000			0.0000
Off-Road	3.1651	31.4407	21.5650	0.0388		1.5513	1.5513		1.4411	1.4411	0.0000	3,747.9449	3,747.9449	1.0549		3,774.3174
Total	3.1651	31.4407	21.5650	0.0388	3.3074	1.5513	4.8588	0.5008	1.4411	1.9419	0.0000	3,747.9449	3,747.9449	1.0549		3,774.3174

Village South Specific Plan (Proposed) - Los Angeles-South Coast County, Summer

3.2 Demolition - 2021

Mitigated Construction Off-Site

	ROG	NOx	CO	SO2	Fugitive PM10	Exhaust PM10	PM10 Total	Fugitive PM2.5	Exhaust PM2.5	PM2.5 Total	Bio- CO2	NBio- CO2	Total CO2	CH4	N2O	CO2e
Category	lb/day										lb/day					
Hauling	0.1273	4.0952	0.9602	0.0119	0.2669	0.0126	0.2795	0.0732	0.0120	0.0852		1,292.2413	1,292.2413	0.0877		1,294.4337
Vendor	0.0000	0.0000	0.0000	0.0000	0.0000	0.0000	0.0000	0.0000	0.0000	0.0000		0.0000	0.0000	0.0000		0.0000
Worker	0.0643	0.0442	0.6042	1.7100e-003	0.1677	1.3500e-003	0.1690	0.0445	1.2500e-003	0.0457		170.8155	170.8155	5.0300e-003		170.9413
Total	0.1916	4.1394	1.5644	0.0136	0.4346	0.0139	0.4485	0.1176	0.0133	0.1309		1,463.0568	1,463.0568	0.0927		1,465.3750

3.3 Site Preparation - 2021

Unmitigated Construction On-Site

	ROG	NOx	CO	SO2	Fugitive PM10	Exhaust PM10	PM10 Total	Fugitive PM2.5	Exhaust PM2.5	PM2.5 Total	Bio- CO2	NBio- CO2	Total CO2	CH4	N2O	CO2e
Category	lb/day										lb/day					
Fugitive Dust					18.0663	0.0000	18.0663	9.9307	0.0000	9.9307			0.0000			0.0000
Off-Road	3.8882	40.4971	21.1543	0.0380		2.0445	2.0445		1.8809	1.8809		3,685.6569	3,685.6569	1.1920		3,715.4573
Total	3.8882	40.4971	21.1543	0.0380	18.0663	2.0445	20.1107	9.9307	1.8809	11.8116		3,685.6569	3,685.6569	1.1920		3,715.4573

Village South Specific Plan (Proposed) - Los Angeles-South Coast County, Summer

3.3 Site Preparation - 2021

Unmitigated Construction Off-Site

	ROG	NOx	CO	SO2	Fugitive PM10	Exhaust PM10	PM10 Total	Fugitive PM2.5	Exhaust PM2.5	PM2.5 Total	Bio- CO2	NBio- CO2	Total CO2	CH4	N2O	CO2e
Category	lb/day										lb/day					
Hauling	0.0000	0.0000	0.0000	0.0000	0.0000	0.0000	0.0000	0.0000	0.0000	0.0000		0.0000	0.0000	0.0000		0.0000
Vendor	0.0000	0.0000	0.0000	0.0000	0.0000	0.0000	0.0000	0.0000	0.0000	0.0000		0.0000	0.0000	0.0000		0.0000
Worker	0.0772	0.0530	0.7250	2.0600e-003	0.2012	1.6300e-003	0.2028	0.0534	1.5000e-003	0.0549		204.9786	204.9786	6.0400e-003		205.1296
Total	0.0772	0.0530	0.7250	2.0600e-003	0.2012	1.6300e-003	0.2028	0.0534	1.5000e-003	0.0549		204.9786	204.9786	6.0400e-003		205.1296

Mitigated Construction On-Site

	ROG	NOx	CO	SO2	Fugitive PM10	Exhaust PM10	PM10 Total	Fugitive PM2.5	Exhaust PM2.5	PM2.5 Total	Bio- CO2	NBio- CO2	Total CO2	CH4	N2O	CO2e
Category	lb/day										lb/day					
Fugitive Dust					18.0663	0.0000	18.0663	9.9307	0.0000	9.9307			0.0000			0.0000
Off-Road	3.8882	40.4971	21.1543	0.0380		2.0445	2.0445		1.8809	1.8809	0.0000	3,685.6569	3,685.6569	1.1920		3,715.4573
Total	3.8882	40.4971	21.1543	0.0380	18.0663	2.0445	20.1107	9.9307	1.8809	11.8116	0.0000	3,685.6569	3,685.6569	1.1920		3,715.4573

Village South Specific Plan (Proposed) - Los Angeles-South Coast County, Summer

3.3 Site Preparation - 2021

Mitigated Construction Off-Site

	ROG	NOx	CO	SO2	Fugitive PM10	Exhaust PM10	PM10 Total	Fugitive PM2.5	Exhaust PM2.5	PM2.5 Total	Bio- CO2	NBio- CO2	Total CO2	CH4	N2O	CO2e
Category	lb/day										lb/day					
Hauling	0.0000	0.0000	0.0000	0.0000	0.0000	0.0000	0.0000	0.0000	0.0000	0.0000		0.0000	0.0000	0.0000		0.0000
Vendor	0.0000	0.0000	0.0000	0.0000	0.0000	0.0000	0.0000	0.0000	0.0000	0.0000		0.0000	0.0000	0.0000		0.0000
Worker	0.0772	0.0530	0.7250	2.0600e-003	0.2012	1.6300e-003	0.2028	0.0534	1.5000e-003	0.0549		204.9786	204.9786	6.0400e-003		205.1296
Total	0.0772	0.0530	0.7250	2.0600e-003	0.2012	1.6300e-003	0.2028	0.0534	1.5000e-003	0.0549		204.9786	204.9786	6.0400e-003		205.1296

3.4 Grading - 2021

Unmitigated Construction On-Site

	ROG	NOx	CO	SO2	Fugitive PM10	Exhaust PM10	PM10 Total	Fugitive PM2.5	Exhaust PM2.5	PM2.5 Total	Bio- CO2	NBio- CO2	Total CO2	CH4	N2O	CO2e
Category	lb/day										lb/day					
Fugitive Dust					8.6733	0.0000	8.6733	3.5965	0.0000	3.5965			0.0000			0.0000
Off-Road	4.1912	46.3998	30.8785	0.0620		1.9853	1.9853		1.8265	1.8265		6,007.0434	6,007.0434	1.9428		6,055.6134
Total	4.1912	46.3998	30.8785	0.0620	8.6733	1.9853	10.6587	3.5965	1.8265	5.4230		6,007.0434	6,007.0434	1.9428		6,055.6134

Village South Specific Plan (Proposed) - Los Angeles-South Coast County, Summer

3.4 Grading - 2021

Unmitigated Construction Off-Site

	ROG	NOx	CO	SO2	Fugitive PM10	Exhaust PM10	PM10 Total	Fugitive PM2.5	Exhaust PM2.5	PM2.5 Total	Bio- CO2	NBio- CO2	Total CO2	CH4	N2O	CO2e
Category	lb/day										lb/day					
Hauling	0.0000	0.0000	0.0000	0.0000	0.0000	0.0000	0.0000	0.0000	0.0000	0.0000		0.0000	0.0000	0.0000		0.0000
Vendor	0.0000	0.0000	0.0000	0.0000	0.0000	0.0000	0.0000	0.0000	0.0000	0.0000		0.0000	0.0000	0.0000		0.0000
Worker	0.0857	0.0589	0.8056	2.2900e-003	0.2236	1.8100e-003	0.2254	0.0593	1.6600e-003	0.0610		227.7540	227.7540	6.7100e-003		227.9217
Total	0.0857	0.0589	0.8056	2.2900e-003	0.2236	1.8100e-003	0.2254	0.0593	1.6600e-003	0.0610		227.7540	227.7540	6.7100e-003		227.9217

Mitigated Construction On-Site

	ROG	NOx	CO	SO2	Fugitive PM10	Exhaust PM10	PM10 Total	Fugitive PM2.5	Exhaust PM2.5	PM2.5 Total	Bio- CO2	NBio- CO2	Total CO2	CH4	N2O	CO2e
Category	lb/day										lb/day					
Fugitive Dust					8.6733	0.0000	8.6733	3.5965	0.0000	3.5965			0.0000			0.0000
Off-Road	4.1912	46.3998	30.8785	0.0620		1.9853	1.9853		1.8265	1.8265	0.0000	6,007.0434	6,007.0434	1.9428		6,055.6134
Total	4.1912	46.3998	30.8785	0.0620	8.6733	1.9853	10.6587	3.5965	1.8265	5.4230	0.0000	6,007.0434	6,007.0434	1.9428		6,055.6134

Village South Specific Plan (Proposed) - Los Angeles-South Coast County, Summer

3.4 Grading - 2021

Mitigated Construction Off-Site

	ROG	NOx	CO	SO2	Fugitive PM10	Exhaust PM10	PM10 Total	Fugitive PM2.5	Exhaust PM2.5	PM2.5 Total	Bio- CO2	NBio- CO2	Total CO2	CH4	N2O	CO2e
Category	lb/day										lb/day					
Hauling	0.0000	0.0000	0.0000	0.0000	0.0000	0.0000	0.0000	0.0000	0.0000	0.0000		0.0000	0.0000	0.0000		0.0000
Vendor	0.0000	0.0000	0.0000	0.0000	0.0000	0.0000	0.0000	0.0000	0.0000	0.0000		0.0000	0.0000	0.0000		0.0000
Worker	0.0857	0.0589	0.8056	2.2900e-003	0.2236	1.8100e-003	0.2254	0.0593	1.6600e-003	0.0610		227.7540	227.7540	6.7100e-003		227.9217
Total	0.0857	0.0589	0.8056	2.2900e-003	0.2236	1.8100e-003	0.2254	0.0593	1.6600e-003	0.0610		227.7540	227.7540	6.7100e-003		227.9217

3.4 Grading - 2022

Unmitigated Construction On-Site

	ROG	NOx	CO	SO2	Fugitive PM10	Exhaust PM10	PM10 Total	Fugitive PM2.5	Exhaust PM2.5	PM2.5 Total	Bio- CO2	NBio- CO2	Total CO2	CH4	N2O	CO2e
Category	lb/day										lb/day					
Fugitive Dust					8.6733	0.0000	8.6733	3.5965	0.0000	3.5965			0.0000			0.0000
Off-Road	3.6248	38.8435	29.0415	0.0621		1.6349	1.6349		1.5041	1.5041		6,011.4105	6,011.4105	1.9442		6,060.0158
Total	3.6248	38.8435	29.0415	0.0621	8.6733	1.6349	10.3082	3.5965	1.5041	5.1006		6,011.4105	6,011.4105	1.9442		6,060.0158

Village South Specific Plan (Proposed) - Los Angeles-South Coast County, Summer

3.4 Grading - 2022

Unmitigated Construction Off-Site

	ROG	NOx	CO	SO2	Fugitive PM10	Exhaust PM10	PM10 Total	Fugitive PM2.5	Exhaust PM2.5	PM2.5 Total	Bio- CO2	NBio- CO2	Total CO2	CH4	N2O	CO2e
Category	lb/day										lb/day					
Hauling	0.0000	0.0000	0.0000	0.0000	0.0000	0.0000	0.0000	0.0000	0.0000	0.0000		0.0000	0.0000	0.0000		0.0000
Vendor	0.0000	0.0000	0.0000	0.0000	0.0000	0.0000	0.0000	0.0000	0.0000	0.0000		0.0000	0.0000	0.0000		0.0000
Worker	0.0803	0.0532	0.7432	2.2100e-003	0.2236	1.7500e-003	0.2253	0.0593	1.6100e-003	0.0609		219.7425	219.7425	6.0600e-003		219.8941
Total	0.0803	0.0532	0.7432	2.2100e-003	0.2236	1.7500e-003	0.2253	0.0593	1.6100e-003	0.0609		219.7425	219.7425	6.0600e-003		219.8941

Mitigated Construction On-Site

	ROG	NOx	CO	SO2	Fugitive PM10	Exhaust PM10	PM10 Total	Fugitive PM2.5	Exhaust PM2.5	PM2.5 Total	Bio- CO2	NBio- CO2	Total CO2	CH4	N2O	CO2e
Category	lb/day										lb/day					
Fugitive Dust					8.6733	0.0000	8.6733	3.5965	0.0000	3.5965			0.0000			0.0000
Off-Road	3.6248	38.8435	29.0415	0.0621		1.6349	1.6349		1.5041	1.5041	0.0000	6,011.4105	6,011.4105	1.9442		6,060.0158
Total	3.6248	38.8435	29.0415	0.0621	8.6733	1.6349	10.3082	3.5965	1.5041	5.1006	0.0000	6,011.4105	6,011.4105	1.9442		6,060.0158

Village South Specific Plan (Proposed) - Los Angeles-South Coast County, Summer

3.4 Grading - 2022

Mitigated Construction Off-Site

	ROG	NOx	CO	SO2	Fugitive PM10	Exhaust PM10	PM10 Total	Fugitive PM2.5	Exhaust PM2.5	PM2.5 Total	Bio- CO2	NBio- CO2	Total CO2	CH4	N2O	CO2e
Category	lb/day										lb/day					
Hauling	0.0000	0.0000	0.0000	0.0000	0.0000	0.0000	0.0000	0.0000	0.0000	0.0000		0.0000	0.0000	0.0000		0.0000
Vendor	0.0000	0.0000	0.0000	0.0000	0.0000	0.0000	0.0000	0.0000	0.0000	0.0000		0.0000	0.0000	0.0000		0.0000
Worker	0.0803	0.0532	0.7432	2.2100e-003	0.2236	1.7500e-003	0.2253	0.0593	1.6100e-003	0.0609		219.7425	219.7425	6.0600e-003		219.8941
Total	0.0803	0.0532	0.7432	2.2100e-003	0.2236	1.7500e-003	0.2253	0.0593	1.6100e-003	0.0609		219.7425	219.7425	6.0600e-003		219.8941

3.5 Building Construction - 2022

Unmitigated Construction On-Site

	ROG	NOx	CO	SO2	Fugitive PM10	Exhaust PM10	PM10 Total	Fugitive PM2.5	Exhaust PM2.5	PM2.5 Total	Bio- CO2	NBio- CO2	Total CO2	CH4	N2O	CO2e
Category	lb/day										lb/day					
Off-Road	1.7062	15.6156	16.3634	0.0269		0.8090	0.8090		0.7612	0.7612		2,554.3336	2,554.3336	0.6120		2,569.6322
Total	1.7062	15.6156	16.3634	0.0269		0.8090	0.8090		0.7612	0.7612		2,554.3336	2,554.3336	0.6120		2,569.6322

Village South Specific Plan (Proposed) - Los Angeles-South Coast County, Summer

3.5 Building Construction - 2022

Unmitigated Construction Off-Site

	ROG	NOx	CO	SO2	Fugitive PM10	Exhaust PM10	PM10 Total	Fugitive PM2.5	Exhaust PM2.5	PM2.5 Total	Bio- CO2	NBio- CO2	Total CO2	CH4	N2O	CO2e
Category	lb/day										lb/day					
Hauling	0.0000	0.0000	0.0000	0.0000	0.0000	0.0000	0.0000	0.0000	0.0000	0.0000		0.0000	0.0000	0.0000		0.0000
Vendor	0.4079	13.2032	3.4341	0.0364	0.9155	0.0248	0.9404	0.2636	0.0237	0.2873		3,896.548 2	3,896.548 2	0.2236		3,902.138 4
Worker	3.2162	2.1318	29.7654	0.0883	8.9533	0.0701	9.0234	2.3745	0.0646	2.4390		8,800.685 7	8,800.685 7	0.2429		8,806.758 2
Total	3.6242	15.3350	33.1995	0.1247	9.8688	0.0949	9.9637	2.6381	0.0883	2.7263		12,697.23 39	12,697.23 39	0.4665		12,708.89 66

Mitigated Construction On-Site

	ROG	NOx	CO	SO2	Fugitive PM10	Exhaust PM10	PM10 Total	Fugitive PM2.5	Exhaust PM2.5	PM2.5 Total	Bio- CO2	NBio- CO2	Total CO2	CH4	N2O	CO2e
Category	lb/day										lb/day					
Off-Road	1.7062	15.6156	16.3634	0.0269		0.8090	0.8090		0.7612	0.7612	0.0000	2,554.333 6	2,554.333 6	0.6120		2,569.632 2
Total	1.7062	15.6156	16.3634	0.0269		0.8090	0.8090		0.7612	0.7612	0.0000	2,554.333 6	2,554.333 6	0.6120		2,569.632 2

Village South Specific Plan (Proposed) - Los Angeles-South Coast County, Summer

3.5 Building Construction - 2022

Mitigated Construction Off-Site

	ROG	NOx	CO	SO2	Fugitive PM10	Exhaust PM10	PM10 Total	Fugitive PM2.5	Exhaust PM2.5	PM2.5 Total	Bio- CO2	NBio- CO2	Total CO2	CH4	N2O	CO2e
Category	lb/day										lb/day					
Hauling	0.0000	0.0000	0.0000	0.0000	0.0000	0.0000	0.0000	0.0000	0.0000	0.0000		0.0000	0.0000	0.0000		0.0000
Vendor	0.4079	13.2032	3.4341	0.0364	0.9155	0.0248	0.9404	0.2636	0.0237	0.2873		3,896.548 2	3,896.548 2	0.2236		3,902.138 4
Worker	3.2162	2.1318	29.7654	0.0883	8.9533	0.0701	9.0234	2.3745	0.0646	2.4390		8,800.685 7	8,800.685 7	0.2429		8,806.758 2
Total	3.6242	15.3350	33.1995	0.1247	9.8688	0.0949	9.9637	2.6381	0.0883	2.7263		12,697.23 39	12,697.23 39	0.4665		12,708.89 66

3.5 Building Construction - 2023

Unmitigated Construction On-Site

	ROG	NOx	CO	SO2	Fugitive PM10	Exhaust PM10	PM10 Total	Fugitive PM2.5	Exhaust PM2.5	PM2.5 Total	Bio- CO2	NBio- CO2	Total CO2	CH4	N2O	CO2e
Category	lb/day										lb/day					
Off-Road	1.5728	14.3849	16.2440	0.0269		0.6997	0.6997		0.6584	0.6584		2,555.209 9	2,555.209 9	0.6079		2,570.406 1
Total	1.5728	14.3849	16.2440	0.0269		0.6997	0.6997		0.6584	0.6584		2,555.209 9	2,555.209 9	0.6079		2,570.406 1

Village South Specific Plan (Proposed) - Los Angeles-South Coast County, Summer

3.5 Building Construction - 2023

Unmitigated Construction Off-Site

	ROG	NOx	CO	SO2	Fugitive PM10	Exhaust PM10	PM10 Total	Fugitive PM2.5	Exhaust PM2.5	PM2.5 Total	Bio- CO2	NBio- CO2	Total CO2	CH4	N2O	CO2e
Category	lb/day										lb/day					
Hauling	0.0000	0.0000	0.0000	0.0000	0.0000	0.0000	0.0000	0.0000	0.0000	0.0000		0.0000	0.0000	0.0000		0.0000
Vendor	0.3027	10.0181	3.1014	0.0352	0.9156	0.0116	0.9271	0.2636	0.0111	0.2747		3,773.876 2	3,773.876 2	0.1982		3,778.830 0
Worker	3.0203	1.9287	27.4113	0.0851	8.9533	0.0681	9.0214	2.3745	0.0627	2.4372		8,478.440 8	8,478.440 8	0.2190		8,483.916 0
Total	3.3229	11.9468	30.5127	0.1203	9.8688	0.0797	9.9485	2.6381	0.0738	2.7118		12,252.31 70	12,252.31 70	0.4172		12,262.74 60

Mitigated Construction On-Site

	ROG	NOx	CO	SO2	Fugitive PM10	Exhaust PM10	PM10 Total	Fugitive PM2.5	Exhaust PM2.5	PM2.5 Total	Bio- CO2	NBio- CO2	Total CO2	CH4	N2O	CO2e
Category	lb/day										lb/day					
Off-Road	1.5728	14.3849	16.2440	0.0269		0.6997	0.6997		0.6584	0.6584	0.0000	2,555.209 9	2,555.209 9	0.6079		2,570.406 1
Total	1.5728	14.3849	16.2440	0.0269		0.6997	0.6997		0.6584	0.6584	0.0000	2,555.209 9	2,555.209 9	0.6079		2,570.406 1

Village South Specific Plan (Proposed) - Los Angeles-South Coast County, Summer

3.5 Building Construction - 2023

Mitigated Construction Off-Site

	ROG	NOx	CO	SO2	Fugitive PM10	Exhaust PM10	PM10 Total	Fugitive PM2.5	Exhaust PM2.5	PM2.5 Total	Bio- CO2	NBio- CO2	Total CO2	CH4	N2O	CO2e
Category	lb/day										lb/day					
Hauling	0.0000	0.0000	0.0000	0.0000	0.0000	0.0000	0.0000	0.0000	0.0000	0.0000		0.0000	0.0000	0.0000		0.0000
Vendor	0.3027	10.0181	3.1014	0.0352	0.9156	0.0116	0.9271	0.2636	0.0111	0.2747		3,773.876 2	3,773.876 2	0.1982		3,778.830 0
Worker	3.0203	1.9287	27.4113	0.0851	8.9533	0.0681	9.0214	2.3745	0.0627	2.4372		8,478.440 8	8,478.440 8	0.2190		8,483.916 0
Total	3.3229	11.9468	30.5127	0.1203	9.8688	0.0797	9.9485	2.6381	0.0738	2.7118		12,252.31 70	12,252.31 70	0.4172		12,262.74 60

3.6 Paving - 2023

Unmitigated Construction On-Site

	ROG	NOx	CO	SO2	Fugitive PM10	Exhaust PM10	PM10 Total	Fugitive PM2.5	Exhaust PM2.5	PM2.5 Total	Bio- CO2	NBio- CO2	Total CO2	CH4	N2O	CO2e
Category	lb/day										lb/day					
Off-Road	1.0327	10.1917	14.5842	0.0228		0.5102	0.5102		0.4694	0.4694		2,207.584 1	2,207.584 1	0.7140		2,225.433 6
Paving	0.0000					0.0000	0.0000		0.0000	0.0000			0.0000			0.0000
Total	1.0327	10.1917	14.5842	0.0228		0.5102	0.5102		0.4694	0.4694		2,207.584 1	2,207.584 1	0.7140		2,225.433 6

Village South Specific Plan (Proposed) - Los Angeles-South Coast County, Summer

3.6 Paving - 2023

Unmitigated Construction Off-Site

	ROG	NOx	CO	SO2	Fugitive PM10	Exhaust PM10	PM10 Total	Fugitive PM2.5	Exhaust PM2.5	PM2.5 Total	Bio- CO2	NBio- CO2	Total CO2	CH4	N2O	CO2e
Category	lb/day										lb/day					
Hauling	0.0000	0.0000	0.0000	0.0000	0.0000	0.0000	0.0000	0.0000	0.0000	0.0000		0.0000	0.0000	0.0000		0.0000
Vendor	0.0000	0.0000	0.0000	0.0000	0.0000	0.0000	0.0000	0.0000	0.0000	0.0000		0.0000	0.0000	0.0000		0.0000
Worker	0.0566	0.0361	0.5133	1.5900e-003	0.1677	1.2800e-003	0.1689	0.0445	1.1700e-003	0.0456		158.7723	158.7723	4.1000e-003		158.8748
Total	0.0566	0.0361	0.5133	1.5900e-003	0.1677	1.2800e-003	0.1689	0.0445	1.1700e-003	0.0456		158.7723	158.7723	4.1000e-003		158.8748

Mitigated Construction On-Site

	ROG	NOx	CO	SO2	Fugitive PM10	Exhaust PM10	PM10 Total	Fugitive PM2.5	Exhaust PM2.5	PM2.5 Total	Bio- CO2	NBio- CO2	Total CO2	CH4	N2O	CO2e
Category	lb/day										lb/day					
Off-Road	1.0327	10.1917	14.5842	0.0228		0.5102	0.5102		0.4694	0.4694	0.0000	2,207.5841	2,207.5841	0.7140		2,225.4336
Paving	0.0000					0.0000	0.0000		0.0000	0.0000			0.0000			0.0000
Total	1.0327	10.1917	14.5842	0.0228		0.5102	0.5102		0.4694	0.4694	0.0000	2,207.5841	2,207.5841	0.7140		2,225.4336

Village South Specific Plan (Proposed) - Los Angeles-South Coast County, Summer

3.6 Paving - 2023

Mitigated Construction Off-Site

	ROG	NOx	CO	SO2	Fugitive PM10	Exhaust PM10	PM10 Total	Fugitive PM2.5	Exhaust PM2.5	PM2.5 Total	Bio- CO2	NBio- CO2	Total CO2	CH4	N2O	CO2e
Category	lb/day										lb/day					
Hauling	0.0000	0.0000	0.0000	0.0000	0.0000	0.0000	0.0000	0.0000	0.0000	0.0000		0.0000	0.0000	0.0000		0.0000
Vendor	0.0000	0.0000	0.0000	0.0000	0.0000	0.0000	0.0000	0.0000	0.0000	0.0000		0.0000	0.0000	0.0000		0.0000
Worker	0.0566	0.0361	0.5133	1.5900e-003	0.1677	1.2800e-003	0.1689	0.0445	1.1700e-003	0.0456		158.7723	158.7723	4.1000e-003		158.8748
Total	0.0566	0.0361	0.5133	1.5900e-003	0.1677	1.2800e-003	0.1689	0.0445	1.1700e-003	0.0456		158.7723	158.7723	4.1000e-003		158.8748

3.6 Paving - 2024

Unmitigated Construction On-Site

	ROG	NOx	CO	SO2	Fugitive PM10	Exhaust PM10	PM10 Total	Fugitive PM2.5	Exhaust PM2.5	PM2.5 Total	Bio- CO2	NBio- CO2	Total CO2	CH4	N2O	CO2e
Category	lb/day										lb/day					
Off-Road	0.9882	9.5246	14.6258	0.0228		0.4685	0.4685		0.4310	0.4310		2,207.5472	2,207.5472	0.7140		2,225.3963
Paving	0.0000					0.0000	0.0000		0.0000	0.0000			0.0000			0.0000
Total	0.9882	9.5246	14.6258	0.0228		0.4685	0.4685		0.4310	0.4310		2,207.5472	2,207.5472	0.7140		2,225.3963

Village South Specific Plan (Proposed) - Los Angeles-South Coast County, Summer

3.6 Paving - 2024

Unmitigated Construction Off-Site

	ROG	NOx	CO	SO2	Fugitive PM10	Exhaust PM10	PM10 Total	Fugitive PM2.5	Exhaust PM2.5	PM2.5 Total	Bio- CO2	NBio- CO2	Total CO2	CH4	N2O	CO2e
Category	lb/day										lb/day					
Hauling	0.0000	0.0000	0.0000	0.0000	0.0000	0.0000	0.0000	0.0000	0.0000	0.0000		0.0000	0.0000	0.0000		0.0000
Vendor	0.0000	0.0000	0.0000	0.0000	0.0000	0.0000	0.0000	0.0000	0.0000	0.0000		0.0000	0.0000	0.0000		0.0000
Worker	0.0535	0.0329	0.4785	1.5400e-003	0.1677	1.2600e-003	0.1689	0.0445	1.1600e-003	0.0456		153.8517	153.8517	3.7600e-003		153.9458
Total	0.0535	0.0329	0.4785	1.5400e-003	0.1677	1.2600e-003	0.1689	0.0445	1.1600e-003	0.0456		153.8517	153.8517	3.7600e-003		153.9458

Mitigated Construction On-Site

	ROG	NOx	CO	SO2	Fugitive PM10	Exhaust PM10	PM10 Total	Fugitive PM2.5	Exhaust PM2.5	PM2.5 Total	Bio- CO2	NBio- CO2	Total CO2	CH4	N2O	CO2e
Category	lb/day										lb/day					
Off-Road	0.9882	9.5246	14.6258	0.0228		0.4685	0.4685		0.4310	0.4310	0.0000	2,207.5472	2,207.5472	0.7140		2,225.3963
Paving	0.0000					0.0000	0.0000		0.0000	0.0000			0.0000			0.0000
Total	0.9882	9.5246	14.6258	0.0228		0.4685	0.4685		0.4310	0.4310	0.0000	2,207.5472	2,207.5472	0.7140		2,225.3963

Village South Specific Plan (Proposed) - Los Angeles-South Coast County, Summer

3.6 Paving - 2024

Mitigated Construction Off-Site

	ROG	NOx	CO	SO2	Fugitive PM10	Exhaust PM10	PM10 Total	Fugitive PM2.5	Exhaust PM2.5	PM2.5 Total	Bio- CO2	NBio- CO2	Total CO2	CH4	N2O	CO2e
Category	lb/day										lb/day					
Hauling	0.0000	0.0000	0.0000	0.0000	0.0000	0.0000	0.0000	0.0000	0.0000	0.0000		0.0000	0.0000	0.0000		0.0000
Vendor	0.0000	0.0000	0.0000	0.0000	0.0000	0.0000	0.0000	0.0000	0.0000	0.0000		0.0000	0.0000	0.0000		0.0000
Worker	0.0535	0.0329	0.4785	1.5400e-003	0.1677	1.2600e-003	0.1689	0.0445	1.1600e-003	0.0456		153.8517	153.8517	3.7600e-003		153.9458
Total	0.0535	0.0329	0.4785	1.5400e-003	0.1677	1.2600e-003	0.1689	0.0445	1.1600e-003	0.0456		153.8517	153.8517	3.7600e-003		153.9458

3.7 Architectural Coating - 2024

Unmitigated Construction On-Site

	ROG	NOx	CO	SO2	Fugitive PM10	Exhaust PM10	PM10 Total	Fugitive PM2.5	Exhaust PM2.5	PM2.5 Total	Bio- CO2	NBio- CO2	Total CO2	CH4	N2O	CO2e
Category	lb/day										lb/day					
Archit. Coating	236.4115					0.0000	0.0000		0.0000	0.0000			0.0000			0.0000
Off-Road	0.1808	1.2188	1.8101	2.9700e-003		0.0609	0.0609		0.0609	0.0609		281.4481	281.4481	0.0159		281.8443
Total	236.5923	1.2188	1.8101	2.9700e-003		0.0609	0.0609		0.0609	0.0609		281.4481	281.4481	0.0159		281.8443

Village South Specific Plan (Proposed) - Los Angeles-South Coast County, Summer

3.7 Architectural Coating - 2024

Unmitigated Construction Off-Site

	ROG	NOx	CO	SO2	Fugitive PM10	Exhaust PM10	PM10 Total	Fugitive PM2.5	Exhaust PM2.5	PM2.5 Total	Bio- CO2	NBio- CO2	Total CO2	CH4	N2O	CO2e
Category	lb/day										lb/day					
Hauling	0.0000	0.0000	0.0000	0.0000	0.0000	0.0000	0.0000	0.0000	0.0000	0.0000		0.0000	0.0000	0.0000		0.0000
Vendor	0.0000	0.0000	0.0000	0.0000	0.0000	0.0000	0.0000	0.0000	0.0000	0.0000		0.0000	0.0000	0.0000		0.0000
Worker	0.5707	0.3513	5.1044	0.0165	1.7884	0.0134	1.8018	0.4743	0.0123	0.4866		1,641.085 2	1,641.085 2	0.0401		1,642.088 6
Total	0.5707	0.3513	5.1044	0.0165	1.7884	0.0134	1.8018	0.4743	0.0123	0.4866		1,641.085 2	1,641.085 2	0.0401		1,642.088 6

Mitigated Construction On-Site

	ROG	NOx	CO	SO2	Fugitive PM10	Exhaust PM10	PM10 Total	Fugitive PM2.5	Exhaust PM2.5	PM2.5 Total	Bio- CO2	NBio- CO2	Total CO2	CH4	N2O	CO2e
Category	lb/day										lb/day					
Archit. Coating	236.4115					0.0000	0.0000		0.0000	0.0000			0.0000			0.0000
Off-Road	0.1808	1.2188	1.8101	2.9700e-003		0.0609	0.0609		0.0609	0.0609	0.0000	281.4481	281.4481	0.0159		281.8443
Total	236.5923	1.2188	1.8101	2.9700e-003		0.0609	0.0609		0.0609	0.0609	0.0000	281.4481	281.4481	0.0159		281.8443

Village South Specific Plan (Proposed) - Los Angeles-South Coast County, Summer

3.7 Architectural Coating - 2024

Mitigated Construction Off-Site

	ROG	NOx	CO	SO2	Fugitive PM10	Exhaust PM10	PM10 Total	Fugitive PM2.5	Exhaust PM2.5	PM2.5 Total	Bio- CO2	NBio- CO2	Total CO2	CH4	N2O	CO2e
Category	lb/day										lb/day					
Hauling	0.0000	0.0000	0.0000	0.0000	0.0000	0.0000	0.0000	0.0000	0.0000	0.0000		0.0000	0.0000	0.0000		0.0000
Vendor	0.0000	0.0000	0.0000	0.0000	0.0000	0.0000	0.0000	0.0000	0.0000	0.0000		0.0000	0.0000	0.0000		0.0000
Worker	0.5707	0.3513	5.1044	0.0165	1.7884	0.0134	1.8018	0.4743	0.0123	0.4866		1,641.085 2	1,641.085 2	0.0401		1,642.088 6
Total	0.5707	0.3513	5.1044	0.0165	1.7884	0.0134	1.8018	0.4743	0.0123	0.4866		1,641.085 2	1,641.085 2	0.0401		1,642.088 6

4.0 Operational Detail - Mobile

4.1 Mitigation Measures Mobile

Village South Specific Plan (Proposed) - Los Angeles-South Coast County, Summer

	ROG	NOx	CO	SO2	Fugitive PM10	Exhaust PM10	PM10 Total	Fugitive PM2.5	Exhaust PM2.5	PM2.5 Total	Bio- CO2	NBio- CO2	Total CO2	CH4	N2O	CO2e
Category	lb/day										lb/day					
Mitigated	9.8489	45.4304	114.8495	0.4917	45.9592	0.3360	46.2951	12.2950	0.3119	12.6070		50,306.60 34	50,306.60 34	2.1807		50,361.12 08
Unmitigated	9.8489	45.4304	114.8495	0.4917	45.9592	0.3360	46.2951	12.2950	0.3119	12.6070		50,306.60 34	50,306.60 34	2.1807		50,361.12 08

4.2 Trip Summary Information

Land Use	Average Daily Trip Rate			Unmitigated	Mitigated
	Weekday	Saturday	Sunday	Annual VMT	Annual VMT
Apartments Low Rise	145.75	154.25	154.00	506,227	506,227
Apartments Mid Rise	4,026.75	3,773.25	4075.50	13,660,065	13,660,065
General Office Building	288.45	62.55	31.05	706,812	706,812
High Turnover (Sit Down Restaurant)	2,368.80	2,873.52	2817.72	3,413,937	3,413,937
Hotel	192.00	187.50	160.00	445,703	445,703
Quality Restaurant	501.12	511.92	461.20	707,488	707,488
Regional Shopping Center	528.08	601.44	357.84	1,112,221	1,112,221
Total	8,050.95	8,164.43	8,057.31	20,552,452	20,552,452

4.3 Trip Type Information

Village South Specific Plan (Proposed) - Los Angeles-South Coast County, Summer

Land Use	Miles			Trip %			Trip Purpose %		
	H-W or C-W	H-S or C-C	H-O or C-NW	H-W or C-W	H-S or C-C	H-O or C-NW	Primary	Diverted	Pass-by
Apartments Low Rise	14.70	5.90	8.70	40.20	19.20	40.60	86	11	3
Apartments Mid Rise	14.70	5.90	8.70	40.20	19.20	40.60	86	11	3
General Office Building	16.60	8.40	6.90	33.00	48.00	19.00	77	19	4
High Turnover (Sit Down Restaurant)	16.60	8.40	6.90	8.50	72.50	19.00	37	20	43
Hotel	16.60	8.40	6.90	19.40	61.60	19.00	58	38	4
Quality Restaurant	16.60	8.40	6.90	12.00	69.00	19.00	38	18	44
Regional Shopping Center	16.60	8.40	6.90	16.30	64.70	19.00	54	35	11

4.4 Fleet Mix

Land Use	LDA	LDT1	LDT2	MDV	LHD1	LHD2	MHD	HHD	OBUS	UBUS	MCY	SBUS	MH
Apartments Low Rise	0.543088	0.044216	0.209971	0.116369	0.014033	0.006332	0.021166	0.033577	0.002613	0.001817	0.005285	0.000712	0.000821
Apartments Mid Rise	0.543088	0.044216	0.209971	0.116369	0.014033	0.006332	0.021166	0.033577	0.002613	0.001817	0.005285	0.000712	0.000821
General Office Building	0.543088	0.044216	0.209971	0.116369	0.014033	0.006332	0.021166	0.033577	0.002613	0.001817	0.005285	0.000712	0.000821
High Turnover (Sit Down Restaurant)	0.543088	0.044216	0.209971	0.116369	0.014033	0.006332	0.021166	0.033577	0.002613	0.001817	0.005285	0.000712	0.000821
Hotel	0.543088	0.044216	0.209971	0.116369	0.014033	0.006332	0.021166	0.033577	0.002613	0.001817	0.005285	0.000712	0.000821
Quality Restaurant	0.543088	0.044216	0.209971	0.116369	0.014033	0.006332	0.021166	0.033577	0.002613	0.001817	0.005285	0.000712	0.000821
Regional Shopping Center	0.543088	0.044216	0.209971	0.116369	0.014033	0.006332	0.021166	0.033577	0.002613	0.001817	0.005285	0.000712	0.000821

5.0 Energy Detail

Historical Energy Use: N

5.1 Mitigation Measures Energy

Village South Specific Plan (Proposed) - Los Angeles-South Coast County, Summer

	ROG	NOx	CO	SO2	Fugitive PM10	Exhaust PM10	PM10 Total	Fugitive PM2.5	Exhaust PM2.5	PM2.5 Total	Bio- CO2	NBio- CO2	Total CO2	CH4	N2O	CO2e
Category	lb/day										lb/day					
NaturalGas Mitigated	0.7660	6.7462	4.2573	0.0418		0.5292	0.5292		0.5292	0.5292		8,355.983 2	8,355.983 2	0.1602	0.1532	8,405.638 7
NaturalGas Unmitigated	0.7660	6.7462	4.2573	0.0418		0.5292	0.5292		0.5292	0.5292		8,355.983 2	8,355.983 2	0.1602	0.1532	8,405.638 7

Village South Specific Plan (Proposed) - Los Angeles-South Coast County, Summer

5.2 Energy by Land Use - NaturalGas

Unmitigated

	NaturalGas Use	ROG	NOx	CO	SO2	Fugitive PM10	Exhaust PM10	PM10 Total	Fugitive PM2.5	Exhaust PM2.5	PM2.5 Total	Bio- CO2	NBio- CO2	Total CO2	CH4	N2O	CO2e
Land Use	kBTU/yr	lb/day										lb/day					
Apartments Low Rise	1119.16	0.0121	0.1031	0.0439	6.6000e-004		8.3400e-003	8.3400e-003		8.3400e-003	8.3400e-003		131.6662	131.6662	2.5200e-003	2.4100e-003	132.4486
Apartments Mid Rise	35784.3	0.3859	3.2978	1.4033	0.0211		0.2666	0.2666		0.2666	0.2666		4,209.9164	4,209.9164	0.0807	0.0772	4,234.9339
General Office Building	1283.42	0.0138	0.1258	0.1057	7.5000e-004		9.5600e-003	9.5600e-003		9.5600e-003	9.5600e-003		150.9911	150.9911	2.8900e-003	2.7700e-003	151.8884
High Turnover (Sit Down Restaurant)	22759.9	0.2455	2.2314	1.8743	0.0134		0.1696	0.1696		0.1696	0.1696		2,677.6342	2,677.6342	0.0513	0.0491	2,693.5460
Hotel	4769.72	0.0514	0.4676	0.3928	2.8100e-003		0.0355	0.0355		0.0355	0.0355		561.1436	561.1436	0.0108	0.0103	564.4782
Quality Restaurant	5057.75	0.0545	0.4959	0.4165	2.9800e-003		0.0377	0.0377		0.0377	0.0377		595.0298	595.0298	0.0114	0.0109	598.5658
Regional Shopping Center	251.616	2.7100e-003	0.0247	0.0207	1.5000e-004		1.8700e-003	1.8700e-003		1.8700e-003	1.8700e-003		29.6019	29.6019	5.7000e-004	5.4000e-004	29.7778
Total		0.7660	6.7463	4.2573	0.0418		0.5292	0.5292		0.5292	0.5292		8,355.9832	8,355.9832	0.1602	0.1532	8,405.6387

Village South Specific Plan (Proposed) - Los Angeles-South Coast County, Summer

5.2 Energy by Land Use - NaturalGas

Mitigated

	NaturalGas Use	ROG	NOx	CO	SO2	Fugitive PM10	Exhaust PM10	PM10 Total	Fugitive PM2.5	Exhaust PM2.5	PM2.5 Total	Bio- CO2	NBio- CO2	Total CO2	CH4	N2O	CO2e
Land Use	kBTU/yr	lb/day										lb/day					
Apartments Low Rise	1.11916	0.0121	0.1031	0.0439	6.6000e-004		8.3400e-003	8.3400e-003		8.3400e-003	8.3400e-003		131.6662	131.6662	2.5200e-003	2.4100e-003	132.4486
Apartments Mid Rise	35.7843	0.3859	3.2978	1.4033	0.0211		0.2666	0.2666		0.2666	0.2666		4,209.9164	4,209.9164	0.0807	0.0772	4,234.9339
General Office Building	1.28342	0.0138	0.1258	0.1057	7.5000e-004		9.5600e-003	9.5600e-003		9.5600e-003	9.5600e-003		150.9911	150.9911	2.8900e-003	2.7700e-003	151.8884
High Turnover (Sit Down Restaurant)	22.7599	0.2455	2.2314	1.8743	0.0134		0.1696	0.1696		0.1696	0.1696		2,677.6342	2,677.6342	0.0513	0.0491	2,693.5460
Hotel	4.76972	0.0514	0.4676	0.3928	2.8100e-003		0.0355	0.0355		0.0355	0.0355		561.1436	561.1436	0.0108	0.0103	564.4782
Quality Restaurant	5.05775	0.0545	0.4959	0.4165	2.9800e-003		0.0377	0.0377		0.0377	0.0377		595.0298	595.0298	0.0114	0.0109	598.5658
Regional Shopping Center	0.251616	2.7100e-003	0.0247	0.0207	1.5000e-004		1.8700e-003	1.8700e-003		1.8700e-003	1.8700e-003		29.6019	29.6019	5.7000e-004	5.4000e-004	29.7778
Total		0.7660	6.7463	4.2573	0.0418		0.5292	0.5292		0.5292	0.5292		8,355.9832	8,355.9832	0.1602	0.1532	8,405.6387

6.0 Area Detail

6.1 Mitigation Measures Area

Village South Specific Plan (Proposed) - Los Angeles-South Coast County, Summer

	ROG	NOx	CO	SO2	Fugitive PM10	Exhaust PM10	PM10 Total	Fugitive PM2.5	Exhaust PM2.5	PM2.5 Total	Bio- CO2	NBio- CO2	Total CO2	CH4	N2O	CO2e
Category	lb/day										lb/day					
Mitigated	30.5020	15.0496	88.4430	0.0944		1.5974	1.5974		1.5974	1.5974	0.0000	18,148.5950	18,148.5950	0.4874	0.3300	18,259.1192
Unmitigated	30.5020	15.0496	88.4430	0.0944		1.5974	1.5974		1.5974	1.5974	0.0000	18,148.5950	18,148.5950	0.4874	0.3300	18,259.1192

6.2 Area by SubCategory

Unmitigated

	ROG	NOx	CO	SO2	Fugitive PM10	Exhaust PM10	PM10 Total	Fugitive PM2.5	Exhaust PM2.5	PM2.5 Total	Bio- CO2	NBio- CO2	Total CO2	CH4	N2O	CO2e
SubCategory	lb/day										lb/day					
Architectural Coating	2.2670					0.0000	0.0000		0.0000	0.0000			0.0000			0.0000
Consumer Products	24.1085					0.0000	0.0000		0.0000	0.0000			0.0000			0.0000
Hearth	1.6500	14.1000	6.0000	0.0900		1.1400	1.1400		1.1400	1.1400	0.0000	18,000.0000	18,000.0000	0.3450	0.3300	18,106.9650
Landscaping	2.4766	0.9496	82.4430	4.3600e-003		0.4574	0.4574		0.4574	0.4574		148.5950	148.5950	0.1424		152.1542
Total	30.5020	15.0496	88.4430	0.0944		1.5974	1.5974		1.5974	1.5974	0.0000	18,148.5950	18,148.5950	0.4874	0.3300	18,259.1192

Village South Specific Plan (Proposed) - Los Angeles-South Coast County, Summer

6.2 Area by SubCategory

Mitigated

	ROG	NOx	CO	SO2	Fugitive PM10	Exhaust PM10	PM10 Total	Fugitive PM2.5	Exhaust PM2.5	PM2.5 Total	Bio- CO2	NBio- CO2	Total CO2	CH4	N2O	CO2e
SubCategory	lb/day										lb/day					
Architectural Coating	2.2670					0.0000	0.0000		0.0000	0.0000			0.0000			0.0000
Consumer Products	24.1085					0.0000	0.0000		0.0000	0.0000			0.0000			0.0000
Hearth	1.6500	14.1000	6.0000	0.0900		1.1400	1.1400		1.1400	1.1400	0.0000	18,000.0000	18,000.0000	0.3450	0.3300	18,106.9650
Landscaping	2.4766	0.9496	82.4430	4.3600e-003		0.4574	0.4574		0.4574	0.4574		148.5950	148.5950	0.1424		152.1542
Total	30.5020	15.0496	88.4430	0.0944		1.5974	1.5974		1.5974	1.5974	0.0000	18,148.5950	18,148.5950	0.4874	0.3300	18,259.1192

7.0 Water Detail

7.1 Mitigation Measures Water

8.0 Waste Detail

8.1 Mitigation Measures Waste

9.0 Operational Offroad

Equipment Type	Number	Hours/Day	Days/Year	Horse Power	Load Factor	Fuel Type
----------------	--------	-----------	-----------	-------------	-------------	-----------

10.0 Stationary Equipment

Village South Specific Plan (Proposed) - Los Angeles-South Coast County, Summer

Fire Pumps and Emergency Generators

Equipment Type	Number	Hours/Day	Hours/Year	Horse Power	Load Factor	Fuel Type
----------------	--------	-----------	------------	-------------	-------------	-----------

Boilers

Equipment Type	Number	Heat Input/Day	Heat Input/Year	Boiler Rating	Fuel Type
----------------	--------	----------------	-----------------	---------------	-----------

User Defined Equipment

Equipment Type	Number
----------------	--------

11.0 Vegetation

Village South Specific Plan (Proposed) - Los Angeles-South Coast County, Winter

Village South Specific Plan (Proposed)
Los Angeles-South Coast County, Winter

1.0 Project Characteristics

1.1 Land Usage

Land Uses	Size	Metric	Lot Acreage	Floor Surface Area	Population
General Office Building	45.00	1000sqft	1.03	45,000.00	0
High Turnover (Sit Down Restaurant)	36.00	1000sqft	0.83	36,000.00	0
Hotel	50.00	Room	1.67	72,600.00	0
Quality Restaurant	8.00	1000sqft	0.18	8,000.00	0
Apartments Low Rise	25.00	Dwelling Unit	1.56	25,000.00	72
Apartments Mid Rise	975.00	Dwelling Unit	25.66	975,000.00	2789
Regional Shopping Center	56.00	1000sqft	1.29	56,000.00	0

1.2 Other Project Characteristics

Urbanization	Urban	Wind Speed (m/s)	2.2	Precipitation Freq (Days)	33
Climate Zone	9			Operational Year	2028
Utility Company	Southern California Edison				
CO2 Intensity (lb/MW hr)	702.44	CH4 Intensity (lb/MW hr)	0.029	N2O Intensity (lb/MW hr)	0.006

1.3 User Entered Comments & Non-Default Data

Village South Specific Plan (Proposed) - Los Angeles-South Coast County, Winter

Project Characteristics - Consistent with the DEIR's model.

Land Use - See SWAPE comment regarding residential and retail land uses.

Construction Phase - See SWAPE comment regarding individual construction phase lengths.

Demolition - Consistent with the DEIR's model. See SWAPE comment regarding demolition.

Vehicle Trips - Saturday trips consistent with the DEIR's model. See SWAPE comment regarding weekday and Sunday trips.

Woodstoves - Woodstoves and wood-burning fireplaces consistent with the DEIR's model. See SWAPE comment regarding gas fireplaces.

Energy Use -

Construction Off-road Equipment Mitigation - See SWAPE comment on construction-related mitigation.

Area Mitigation - See SWAPE comment regarding operational mitigation measures.

Water Mitigation - See SWAPE comment regarding operational mitigation measures.

Table Name	Column Name	Default Value	New Value
tblFireplaces	FireplaceWoodMass	1,019.20	0.00
tblFireplaces	FireplaceWoodMass	1,019.20	0.00
tblFireplaces	NumberWood	1.25	0.00
tblFireplaces	NumberWood	48.75	0.00
tblVehicleTrips	ST_TR	7.16	6.17
tblVehicleTrips	ST_TR	6.39	3.87
tblVehicleTrips	ST_TR	2.46	1.39
tblVehicleTrips	ST_TR	158.37	79.82
tblVehicleTrips	ST_TR	8.19	3.75
tblVehicleTrips	ST_TR	94.36	63.99
tblVehicleTrips	ST_TR	49.97	10.74
tblVehicleTrips	SU_TR	6.07	6.16
tblVehicleTrips	SU_TR	5.86	4.18
tblVehicleTrips	SU_TR	1.05	0.69
tblVehicleTrips	SU_TR	131.84	78.27

Village South Specific Plan (Proposed) - Los Angeles-South Coast County, Winter

tblVehicleTrips	SU_TR	5.95	3.20
tblVehicleTrips	SU_TR	72.16	57.65
tblVehicleTrips	SU_TR	25.24	6.39
tblVehicleTrips	WD_TR	6.59	5.83
tblVehicleTrips	WD_TR	6.65	4.13
tblVehicleTrips	WD_TR	11.03	6.41
tblVehicleTrips	WD_TR	127.15	65.80
tblVehicleTrips	WD_TR	8.17	3.84
tblVehicleTrips	WD_TR	89.95	62.64
tblVehicleTrips	WD_TR	42.70	9.43
tblWoodstoves	NumberCatalytic	1.25	0.00
tblWoodstoves	NumberCatalytic	48.75	0.00
tblWoodstoves	NumberNoncatalytic	1.25	0.00
tblWoodstoves	NumberNoncatalytic	48.75	0.00
tblWoodstoves	WoodstoveDayYear	25.00	0.00
tblWoodstoves	WoodstoveDayYear	25.00	0.00
tblWoodstoves	WoodstoveWoodMass	999.60	0.00
tblWoodstoves	WoodstoveWoodMass	999.60	0.00

2.0 Emissions Summary

Village South Specific Plan (Proposed) - Los Angeles-South Coast County, Winter

2.1 Overall Construction (Maximum Daily Emission)

Unmitigated Construction

	ROG	NOx	CO	SO2	Fugitive PM10	Exhaust PM10	PM10 Total	Fugitive PM2.5	Exhaust PM2.5	PM2.5 Total	Bio- CO2	NBio- CO2	Total CO2	CH4	N2O	CO2e
Year	lb/day										lb/day					
2021	4.2865	46.4651	31.6150	0.0642	18.2675	2.0461	20.3135	9.9840	1.8824	11.8664	0.0000	6,221.4937	6,221.4937	1.9491	0.0000	6,270.2214
2022	5.7218	38.9024	47.3319	0.1455	9.8688	1.6366	10.7736	3.6558	1.5057	5.1615	0.0000	14,630.3099	14,630.3099	1.9499	0.0000	14,657.2663
2023	5.2705	26.4914	44.5936	0.1413	9.8688	0.7800	10.6488	2.6381	0.7328	3.3708	0.0000	14,210.3424	14,210.3424	1.0230	0.0000	14,235.9160
2024	237.2328	9.5610	15.0611	0.0243	1.7884	0.4698	1.8628	0.4743	0.4322	0.5476	0.0000	2,352.4178	2,352.4178	0.7175	0.0000	2,370.3550
Maximum	237.2328	46.4651	47.3319	0.1455	18.2675	2.0461	20.3135	9.9840	1.8824	11.8664	0.0000	14,630.3099	14,630.3099	1.9499	0.0000	14,657.2663

Village South Specific Plan (Proposed) - Los Angeles-South Coast County, Winter

2.2 Overall Operational

Unmitigated Operational

	ROG	NOx	CO	SO2	Fugitive PM10	Exhaust PM10	PM10 Total	Fugitive PM2.5	Exhaust PM2.5	PM2.5 Total	Bio- CO2	NBio- CO2	Total CO2	CH4	N2O	CO2e
Category	lb/day										lb/day					
Area	30.5020	15.0496	88.4430	0.0944		1.5974	1.5974		1.5974	1.5974	0.0000	18,148.59 50	18,148.59 50	0.4874	0.3300	18,259.11 92
Energy	0.7660	6.7462	4.2573	0.0418		0.5292	0.5292		0.5292	0.5292		8,355.983 2	8,355.983 2	0.1602	0.1532	8,405.638 7
Mobile	9.5233	45.9914	110.0422	0.4681	45.9592	0.3373	46.2965	12.2950	0.3132	12.6083		47,917.80 05	47,917.80 05	2.1953		47,972.68 39
Total	40.7912	67.7872	202.7424	0.6043	45.9592	2.4640	48.4231	12.2950	2.4399	14.7349	0.0000	74,422.37 87	74,422.37 87	2.8429	0.4832	74,637.44 17

Mitigated Operational

	ROG	NOx	CO	SO2	Fugitive PM10	Exhaust PM10	PM10 Total	Fugitive PM2.5	Exhaust PM2.5	PM2.5 Total	Bio- CO2	NBio- CO2	Total CO2	CH4	N2O	CO2e
Category	lb/day										lb/day					
Area	30.5020	15.0496	88.4430	0.0944		1.5974	1.5974		1.5974	1.5974	0.0000	18,148.59 50	18,148.59 50	0.4874	0.3300	18,259.11 92
Energy	0.7660	6.7462	4.2573	0.0418		0.5292	0.5292		0.5292	0.5292		8,355.983 2	8,355.983 2	0.1602	0.1532	8,405.638 7
Mobile	9.5233	45.9914	110.0422	0.4681	45.9592	0.3373	46.2965	12.2950	0.3132	12.6083		47,917.80 05	47,917.80 05	2.1953		47,972.68 39
Total	40.7912	67.7872	202.7424	0.6043	45.9592	2.4640	48.4231	12.2950	2.4399	14.7349	0.0000	74,422.37 87	74,422.37 87	2.8429	0.4832	74,637.44 17

Village South Specific Plan (Proposed) - Los Angeles-South Coast County, Winter

	ROG	NOx	CO	SO2	Fugitive PM10	Exhaust PM10	PM10 Total	Fugitive PM2.5	Exhaust PM2.5	PM2.5 Total	Bio- CO2	NBio-CO2	Total CO2	CH4	N2O	CO2e
Percent Reduction	0.00	0.00	0.00	0.00	0.00	0.00	0.00	0.00	0.00	0.00	0.00	0.00	0.00	0.00	0.00	0.00

3.0 Construction Detail

Construction Phase

Phase Number	Phase Name	Phase Type	Start Date	End Date	Num Days Week	Num Days	Phase Description
1	Demolition	Demolition	9/1/2021	10/12/2021	5	30	
2	Site Preparation	Site Preparation	10/13/2021	11/9/2021	5	20	
3	Grading	Grading	11/10/2021	1/11/2022	5	45	
4	Building Construction	Building Construction	1/12/2022	12/12/2023	5	500	
5	Paving	Paving	12/13/2023	1/30/2024	5	35	
6	Architectural Coating	Architectural Coating	1/31/2024	3/19/2024	5	35	

Acres of Grading (Site Preparation Phase): 0

Acres of Grading (Grading Phase): 112.5

Acres of Paving: 0

Residential Indoor: 2,025,000; Residential Outdoor: 675,000; Non-Residential Indoor: 326,400; Non-Residential Outdoor: 108,800; Striped Parking Area: 0 (Architectural Coating – sqft)

OffRoad Equipment

Village South Specific Plan (Proposed) - Los Angeles-South Coast County, Winter

Phase Name	Offroad Equipment Type	Amount	Usage Hours	Horse Power	Load Factor
Demolition	Concrete/Industrial Saws	1	8.00	81	0.73
Demolition	Excavators	3	8.00	158	0.38
Demolition	Rubber Tired Dozers	2	8.00	247	0.40
Site Preparation	Rubber Tired Dozers	3	8.00	247	0.40
Site Preparation	Tractors/Loaders/Backhoes	4	8.00	97	0.37
Grading	Excavators	2	8.00	158	0.38
Grading	Graders	1	8.00	187	0.41
Grading	Rubber Tired Dozers	1	8.00	247	0.40
Grading	Scrapers	2	8.00	367	0.48
Grading	Tractors/Loaders/Backhoes	2	8.00	97	0.37
Building Construction	Cranes	1	7.00	231	0.29
Building Construction	Forklifts	3	8.00	89	0.20
Building Construction	Generator Sets	1	8.00	84	0.74
Building Construction	Tractors/Loaders/Backhoes	3	7.00	97	0.37
Building Construction	Welders	1	8.00	46	0.45
Paving	Pavers	2	8.00	130	0.42
Paving	Paving Equipment	2	8.00	132	0.36
Paving	Rollers	2	8.00	80	0.38
Architectural Coating	Air Compressors	1	6.00	78	0.48

Trips and VMT

Village South Specific Plan (Proposed) - Los Angeles-South Coast County, Winter

Phase Name	Offroad Equipment Count	Worker Trip Number	Vendor Trip Number	Hauling Trip Number	Worker Trip Length	Vendor Trip Length	Hauling Trip Length	Worker Vehicle Class	Vendor Vehicle Class	Hauling Vehicle Class
Demolition	6	15.00	0.00	458.00	14.70	6.90	20.00	LD_Mix	HDT_Mix	HHDT
Site Preparation	7	18.00	0.00	0.00	14.70	6.90	20.00	LD_Mix	HDT_Mix	HHDT
Grading	8	20.00	0.00	0.00	14.70	6.90	20.00	LD_Mix	HDT_Mix	HHDT
Building Construction	9	801.00	143.00	0.00	14.70	6.90	20.00	LD_Mix	HDT_Mix	HHDT
Paving	6	15.00	0.00	0.00	14.70	6.90	20.00	LD_Mix	HDT_Mix	HHDT
Architectural Coating	1	160.00	0.00	0.00	14.70	6.90	20.00	LD_Mix	HDT_Mix	HHDT

3.1 Mitigation Measures Construction

3.2 Demolition - 2021

Unmitigated Construction On-Site

	ROG	NOx	CO	SO2	Fugitive PM10	Exhaust PM10	PM10 Total	Fugitive PM2.5	Exhaust PM2.5	PM2.5 Total	Bio- CO2	NBio- CO2	Total CO2	CH4	N2O	CO2e
Category	lb/day										lb/day					
Fugitive Dust					3.3074	0.0000	3.3074	0.5008	0.0000	0.5008			0.0000			0.0000
Off-Road	3.1651	31.4407	21.5650	0.0388		1.5513	1.5513		1.4411	1.4411		3,747.9449	3,747.9449	1.0549		3,774.3174
Total	3.1651	31.4407	21.5650	0.0388	3.3074	1.5513	4.8588	0.5008	1.4411	1.9419		3,747.9449	3,747.9449	1.0549		3,774.3174

Village South Specific Plan (Proposed) - Los Angeles-South Coast County, Winter

3.2 Demolition - 2021

Unmitigated Construction Off-Site

	ROG	NOx	CO	SO2	Fugitive PM10	Exhaust PM10	PM10 Total	Fugitive PM2.5	Exhaust PM2.5	PM2.5 Total	Bio- CO2	NBio- CO2	Total CO2	CH4	N2O	CO2e
Category	lb/day										lb/day					
Hauling	0.1304	4.1454	1.0182	0.0117	0.2669	0.0128	0.2797	0.0732	0.0122	0.0854		1,269.8555	1,269.8555	0.0908		1,272.1252
Vendor	0.0000	0.0000	0.0000	0.0000	0.0000	0.0000	0.0000	0.0000	0.0000	0.0000		0.0000	0.0000	0.0000		0.0000
Worker	0.0715	0.0489	0.5524	1.6100e-003	0.1677	1.3500e-003	0.1690	0.0445	1.2500e-003	0.0457		160.8377	160.8377	4.7300e-003		160.9560
Total	0.2019	4.1943	1.5706	0.0133	0.4346	0.0141	0.4487	0.1176	0.0135	0.1311		1,430.6932	1,430.6932	0.0955		1,433.0812

Mitigated Construction On-Site

	ROG	NOx	CO	SO2	Fugitive PM10	Exhaust PM10	PM10 Total	Fugitive PM2.5	Exhaust PM2.5	PM2.5 Total	Bio- CO2	NBio- CO2	Total CO2	CH4	N2O	CO2e
Category	lb/day										lb/day					
Fugitive Dust					3.3074	0.0000	3.3074	0.5008	0.0000	0.5008			0.0000			0.0000
Off-Road	3.1651	31.4407	21.5650	0.0388		1.5513	1.5513		1.4411	1.4411	0.0000	3,747.9449	3,747.9449	1.0549		3,774.3174
Total	3.1651	31.4407	21.5650	0.0388	3.3074	1.5513	4.8588	0.5008	1.4411	1.9419	0.0000	3,747.9449	3,747.9449	1.0549		3,774.3174

Village South Specific Plan (Proposed) - Los Angeles-South Coast County, Winter

3.2 Demolition - 2021

Mitigated Construction Off-Site

	ROG	NOx	CO	SO2	Fugitive PM10	Exhaust PM10	PM10 Total	Fugitive PM2.5	Exhaust PM2.5	PM2.5 Total	Bio- CO2	NBio- CO2	Total CO2	CH4	N2O	CO2e
Category	lb/day										lb/day					
Hauling	0.1304	4.1454	1.0182	0.0117	0.2669	0.0128	0.2797	0.0732	0.0122	0.0854		1,269.8555	1,269.8555	0.0908		1,272.1252
Vendor	0.0000	0.0000	0.0000	0.0000	0.0000	0.0000	0.0000	0.0000	0.0000	0.0000		0.0000	0.0000	0.0000		0.0000
Worker	0.0715	0.0489	0.5524	1.6100e-003	0.1677	1.3500e-003	0.1690	0.0445	1.2500e-003	0.0457		160.8377	160.8377	4.7300e-003		160.9560
Total	0.2019	4.1943	1.5706	0.0133	0.4346	0.0141	0.4487	0.1176	0.0135	0.1311		1,430.6932	1,430.6932	0.0955		1,433.0812

3.3 Site Preparation - 2021

Unmitigated Construction On-Site

	ROG	NOx	CO	SO2	Fugitive PM10	Exhaust PM10	PM10 Total	Fugitive PM2.5	Exhaust PM2.5	PM2.5 Total	Bio- CO2	NBio- CO2	Total CO2	CH4	N2O	CO2e
Category	lb/day										lb/day					
Fugitive Dust					18.0663	0.0000	18.0663	9.9307	0.0000	9.9307			0.0000			0.0000
Off-Road	3.8882	40.4971	21.1543	0.0380		2.0445	2.0445		1.8809	1.8809		3,685.6569	3,685.6569	1.1920		3,715.4573
Total	3.8882	40.4971	21.1543	0.0380	18.0663	2.0445	20.1107	9.9307	1.8809	11.8116		3,685.6569	3,685.6569	1.1920		3,715.4573

Village South Specific Plan (Proposed) - Los Angeles-South Coast County, Winter

3.3 Site Preparation - 2021

Unmitigated Construction Off-Site

	ROG	NOx	CO	SO2	Fugitive PM10	Exhaust PM10	PM10 Total	Fugitive PM2.5	Exhaust PM2.5	PM2.5 Total	Bio- CO2	NBio- CO2	Total CO2	CH4	N2O	CO2e
Category	lb/day										lb/day					
Hauling	0.0000	0.0000	0.0000	0.0000	0.0000	0.0000	0.0000	0.0000	0.0000	0.0000		0.0000	0.0000	0.0000		0.0000
Vendor	0.0000	0.0000	0.0000	0.0000	0.0000	0.0000	0.0000	0.0000	0.0000	0.0000		0.0000	0.0000	0.0000		0.0000
Worker	0.0858	0.0587	0.6629	1.9400e-003	0.2012	1.6300e-003	0.2028	0.0534	1.5000e-003	0.0549		193.0052	193.0052	5.6800e-003		193.1472
Total	0.0858	0.0587	0.6629	1.9400e-003	0.2012	1.6300e-003	0.2028	0.0534	1.5000e-003	0.0549		193.0052	193.0052	5.6800e-003		193.1472

Mitigated Construction On-Site

	ROG	NOx	CO	SO2	Fugitive PM10	Exhaust PM10	PM10 Total	Fugitive PM2.5	Exhaust PM2.5	PM2.5 Total	Bio- CO2	NBio- CO2	Total CO2	CH4	N2O	CO2e
Category	lb/day										lb/day					
Fugitive Dust					18.0663	0.0000	18.0663	9.9307	0.0000	9.9307			0.0000			0.0000
Off-Road	3.8882	40.4971	21.1543	0.0380		2.0445	2.0445		1.8809	1.8809	0.0000	3,685.6569	3,685.6569	1.1920		3,715.4573
Total	3.8882	40.4971	21.1543	0.0380	18.0663	2.0445	20.1107	9.9307	1.8809	11.8116	0.0000	3,685.6569	3,685.6569	1.1920		3,715.4573

Village South Specific Plan (Proposed) - Los Angeles-South Coast County, Winter

3.3 Site Preparation - 2021

Mitigated Construction Off-Site

	ROG	NOx	CO	SO2	Fugitive PM10	Exhaust PM10	PM10 Total	Fugitive PM2.5	Exhaust PM2.5	PM2.5 Total	Bio- CO2	NBio- CO2	Total CO2	CH4	N2O	CO2e
Category	lb/day										lb/day					
Hauling	0.0000	0.0000	0.0000	0.0000	0.0000	0.0000	0.0000	0.0000	0.0000	0.0000		0.0000	0.0000	0.0000		0.0000
Vendor	0.0000	0.0000	0.0000	0.0000	0.0000	0.0000	0.0000	0.0000	0.0000	0.0000		0.0000	0.0000	0.0000		0.0000
Worker	0.0858	0.0587	0.6629	1.9400e-003	0.2012	1.6300e-003	0.2028	0.0534	1.5000e-003	0.0549		193.0052	193.0052	5.6800e-003		193.1472
Total	0.0858	0.0587	0.6629	1.9400e-003	0.2012	1.6300e-003	0.2028	0.0534	1.5000e-003	0.0549		193.0052	193.0052	5.6800e-003		193.1472

3.4 Grading - 2021

Unmitigated Construction On-Site

	ROG	NOx	CO	SO2	Fugitive PM10	Exhaust PM10	PM10 Total	Fugitive PM2.5	Exhaust PM2.5	PM2.5 Total	Bio- CO2	NBio- CO2	Total CO2	CH4	N2O	CO2e
Category	lb/day										lb/day					
Fugitive Dust					8.6733	0.0000	8.6733	3.5965	0.0000	3.5965			0.0000			0.0000
Off-Road	4.1912	46.3998	30.8785	0.0620		1.9853	1.9853		1.8265	1.8265		6,007.0434	6,007.0434	1.9428		6,055.6134
Total	4.1912	46.3998	30.8785	0.0620	8.6733	1.9853	10.6587	3.5965	1.8265	5.4230		6,007.0434	6,007.0434	1.9428		6,055.6134

Village South Specific Plan (Proposed) - Los Angeles-South Coast County, Winter

3.4 Grading - 2021

Unmitigated Construction Off-Site

	ROG	NOx	CO	SO2	Fugitive PM10	Exhaust PM10	PM10 Total	Fugitive PM2.5	Exhaust PM2.5	PM2.5 Total	Bio- CO2	NBio- CO2	Total CO2	CH4	N2O	CO2e
Category	lb/day										lb/day					
Hauling	0.0000	0.0000	0.0000	0.0000	0.0000	0.0000	0.0000	0.0000	0.0000	0.0000		0.0000	0.0000	0.0000		0.0000
Vendor	0.0000	0.0000	0.0000	0.0000	0.0000	0.0000	0.0000	0.0000	0.0000	0.0000		0.0000	0.0000	0.0000		0.0000
Worker	0.0954	0.0652	0.7365	2.1500e-003	0.2236	1.8100e-003	0.2254	0.0593	1.6600e-003	0.0610		214.4502	214.4502	6.3100e-003		214.6080
Total	0.0954	0.0652	0.7365	2.1500e-003	0.2236	1.8100e-003	0.2254	0.0593	1.6600e-003	0.0610		214.4502	214.4502	6.3100e-003		214.6080

Mitigated Construction On-Site

	ROG	NOx	CO	SO2	Fugitive PM10	Exhaust PM10	PM10 Total	Fugitive PM2.5	Exhaust PM2.5	PM2.5 Total	Bio- CO2	NBio- CO2	Total CO2	CH4	N2O	CO2e
Category	lb/day										lb/day					
Fugitive Dust					8.6733	0.0000	8.6733	3.5965	0.0000	3.5965			0.0000			0.0000
Off-Road	4.1912	46.3998	30.8785	0.0620		1.9853	1.9853		1.8265	1.8265	0.0000	6,007.0434	6,007.0434	1.9428		6,055.6134
Total	4.1912	46.3998	30.8785	0.0620	8.6733	1.9853	10.6587	3.5965	1.8265	5.4230	0.0000	6,007.0434	6,007.0434	1.9428		6,055.6134

Village South Specific Plan (Proposed) - Los Angeles-South Coast County, Winter

3.4 Grading - 2021

Mitigated Construction Off-Site

	ROG	NOx	CO	SO2	Fugitive PM10	Exhaust PM10	PM10 Total	Fugitive PM2.5	Exhaust PM2.5	PM2.5 Total	Bio- CO2	NBio- CO2	Total CO2	CH4	N2O	CO2e
Category	lb/day										lb/day					
Hauling	0.0000	0.0000	0.0000	0.0000	0.0000	0.0000	0.0000	0.0000	0.0000	0.0000		0.0000	0.0000	0.0000		0.0000
Vendor	0.0000	0.0000	0.0000	0.0000	0.0000	0.0000	0.0000	0.0000	0.0000	0.0000		0.0000	0.0000	0.0000		0.0000
Worker	0.0954	0.0652	0.7365	2.1500e-003	0.2236	1.8100e-003	0.2254	0.0593	1.6600e-003	0.0610		214.4502	214.4502	6.3100e-003		214.6080
Total	0.0954	0.0652	0.7365	2.1500e-003	0.2236	1.8100e-003	0.2254	0.0593	1.6600e-003	0.0610		214.4502	214.4502	6.3100e-003		214.6080

3.4 Grading - 2022

Unmitigated Construction On-Site

	ROG	NOx	CO	SO2	Fugitive PM10	Exhaust PM10	PM10 Total	Fugitive PM2.5	Exhaust PM2.5	PM2.5 Total	Bio- CO2	NBio- CO2	Total CO2	CH4	N2O	CO2e
Category	lb/day										lb/day					
Fugitive Dust					8.6733	0.0000	8.6733	3.5965	0.0000	3.5965			0.0000			0.0000
Off-Road	3.6248	38.8435	29.0415	0.0621		1.6349	1.6349		1.5041	1.5041		6,011.4105	6,011.4105	1.9442		6,060.0158
Total	3.6248	38.8435	29.0415	0.0621	8.6733	1.6349	10.3082	3.5965	1.5041	5.1006		6,011.4105	6,011.4105	1.9442		6,060.0158

Village South Specific Plan (Proposed) - Los Angeles-South Coast County, Winter

3.4 Grading - 2022

Unmitigated Construction Off-Site

	ROG	NOx	CO	SO2	Fugitive PM10	Exhaust PM10	PM10 Total	Fugitive PM2.5	Exhaust PM2.5	PM2.5 Total	Bio- CO2	NBio- CO2	Total CO2	CH4	N2O	CO2e
Category	lb/day										lb/day					
Hauling	0.0000	0.0000	0.0000	0.0000	0.0000	0.0000	0.0000	0.0000	0.0000	0.0000		0.0000	0.0000	0.0000		0.0000
Vendor	0.0000	0.0000	0.0000	0.0000	0.0000	0.0000	0.0000	0.0000	0.0000	0.0000		0.0000	0.0000	0.0000		0.0000
Worker	0.0896	0.0589	0.6784	2.0800e-003	0.2236	1.7500e-003	0.2253	0.0593	1.6100e-003	0.0609		206.9139	206.9139	5.7000e-003		207.0563
Total	0.0896	0.0589	0.6784	2.0800e-003	0.2236	1.7500e-003	0.2253	0.0593	1.6100e-003	0.0609		206.9139	206.9139	5.7000e-003		207.0563

Mitigated Construction On-Site

	ROG	NOx	CO	SO2	Fugitive PM10	Exhaust PM10	PM10 Total	Fugitive PM2.5	Exhaust PM2.5	PM2.5 Total	Bio- CO2	NBio- CO2	Total CO2	CH4	N2O	CO2e
Category	lb/day										lb/day					
Fugitive Dust					8.6733	0.0000	8.6733	3.5965	0.0000	3.5965			0.0000			0.0000
Off-Road	3.6248	38.8435	29.0415	0.0621		1.6349	1.6349		1.5041	1.5041	0.0000	6,011.4105	6,011.4105	1.9442		6,060.0158
Total	3.6248	38.8435	29.0415	0.0621	8.6733	1.6349	10.3082	3.5965	1.5041	5.1006	0.0000	6,011.4105	6,011.4105	1.9442		6,060.0158

Village South Specific Plan (Proposed) - Los Angeles-South Coast County, Winter

3.4 Grading - 2022

Mitigated Construction Off-Site

	ROG	NOx	CO	SO2	Fugitive PM10	Exhaust PM10	PM10 Total	Fugitive PM2.5	Exhaust PM2.5	PM2.5 Total	Bio- CO2	NBio- CO2	Total CO2	CH4	N2O	CO2e
Category	lb/day										lb/day					
Hauling	0.0000	0.0000	0.0000	0.0000	0.0000	0.0000	0.0000	0.0000	0.0000	0.0000		0.0000	0.0000	0.0000		0.0000
Vendor	0.0000	0.0000	0.0000	0.0000	0.0000	0.0000	0.0000	0.0000	0.0000	0.0000		0.0000	0.0000	0.0000		0.0000
Worker	0.0896	0.0589	0.6784	2.0800e-003	0.2236	1.7500e-003	0.2253	0.0593	1.6100e-003	0.0609		206.9139	206.9139	5.7000e-003		207.0563
Total	0.0896	0.0589	0.6784	2.0800e-003	0.2236	1.7500e-003	0.2253	0.0593	1.6100e-003	0.0609		206.9139	206.9139	5.7000e-003		207.0563

3.5 Building Construction - 2022

Unmitigated Construction On-Site

	ROG	NOx	CO	SO2	Fugitive PM10	Exhaust PM10	PM10 Total	Fugitive PM2.5	Exhaust PM2.5	PM2.5 Total	Bio- CO2	NBio- CO2	Total CO2	CH4	N2O	CO2e
Category	lb/day										lb/day					
Off-Road	1.7062	15.6156	16.3634	0.0269		0.8090	0.8090		0.7612	0.7612		2,554.3336	2,554.3336	0.6120		2,569.6322
Total	1.7062	15.6156	16.3634	0.0269		0.8090	0.8090		0.7612	0.7612		2,554.3336	2,554.3336	0.6120		2,569.6322

Village South Specific Plan (Proposed) - Los Angeles-South Coast County, Winter

3.5 Building Construction - 2022

Unmitigated Construction Off-Site

	ROG	NOx	CO	SO2	Fugitive PM10	Exhaust PM10	PM10 Total	Fugitive PM2.5	Exhaust PM2.5	PM2.5 Total	Bio- CO2	NBio- CO2	Total CO2	CH4	N2O	CO2e
Category	lb/day										lb/day					
Hauling	0.0000	0.0000	0.0000	0.0000	0.0000	0.0000	0.0000	0.0000	0.0000	0.0000		0.0000	0.0000	0.0000		0.0000
Vendor	0.4284	13.1673	3.8005	0.0354	0.9155	0.0256	0.9412	0.2636	0.0245	0.2881		3,789.0750	3,789.0750	0.2381		3,795.0283
Worker	3.5872	2.3593	27.1680	0.0832	8.9533	0.0701	9.0234	2.3745	0.0646	2.4390		8,286.9013	8,286.9013	0.2282		8,292.6058
Total	4.0156	15.5266	30.9685	0.1186	9.8688	0.0957	9.9645	2.6381	0.0891	2.7271		12,075.9763	12,075.9763	0.4663		12,087.6341

Mitigated Construction On-Site

	ROG	NOx	CO	SO2	Fugitive PM10	Exhaust PM10	PM10 Total	Fugitive PM2.5	Exhaust PM2.5	PM2.5 Total	Bio- CO2	NBio- CO2	Total CO2	CH4	N2O	CO2e
Category	lb/day										lb/day					
Off-Road	1.7062	15.6156	16.3634	0.0269		0.8090	0.8090		0.7612	0.7612	0.0000	2,554.3336	2,554.3336	0.6120		2,569.6322
Total	1.7062	15.6156	16.3634	0.0269		0.8090	0.8090		0.7612	0.7612	0.0000	2,554.3336	2,554.3336	0.6120		2,569.6322

Village South Specific Plan (Proposed) - Los Angeles-South Coast County, Winter

3.5 Building Construction - 2022

Mitigated Construction Off-Site

	ROG	NOx	CO	SO2	Fugitive PM10	Exhaust PM10	PM10 Total	Fugitive PM2.5	Exhaust PM2.5	PM2.5 Total	Bio- CO2	NBio- CO2	Total CO2	CH4	N2O	CO2e
Category	lb/day										lb/day					
Hauling	0.0000	0.0000	0.0000	0.0000	0.0000	0.0000	0.0000	0.0000	0.0000	0.0000		0.0000	0.0000	0.0000		0.0000
Vendor	0.4284	13.1673	3.8005	0.0354	0.9155	0.0256	0.9412	0.2636	0.0245	0.2881		3,789.0750	3,789.0750	0.2381		3,795.0283
Worker	3.5872	2.3593	27.1680	0.0832	8.9533	0.0701	9.0234	2.3745	0.0646	2.4390		8,286.9013	8,286.9013	0.2282		8,292.6058
Total	4.0156	15.5266	30.9685	0.1186	9.8688	0.0957	9.9645	2.6381	0.0891	2.7271		12,075.9763	12,075.9763	0.4663		12,087.6341

3.5 Building Construction - 2023

Unmitigated Construction On-Site

	ROG	NOx	CO	SO2	Fugitive PM10	Exhaust PM10	PM10 Total	Fugitive PM2.5	Exhaust PM2.5	PM2.5 Total	Bio- CO2	NBio- CO2	Total CO2	CH4	N2O	CO2e
Category	lb/day										lb/day					
Off-Road	1.5728	14.3849	16.2440	0.0269		0.6997	0.6997		0.6584	0.6584		2,555.2099	2,555.2099	0.6079		2,570.4061
Total	1.5728	14.3849	16.2440	0.0269		0.6997	0.6997		0.6584	0.6584		2,555.2099	2,555.2099	0.6079		2,570.4061

Village South Specific Plan (Proposed) - Los Angeles-South Coast County, Winter

3.5 Building Construction - 2023

Unmitigated Construction Off-Site

	ROG	NOx	CO	SO2	Fugitive PM10	Exhaust PM10	PM10 Total	Fugitive PM2.5	Exhaust PM2.5	PM2.5 Total	Bio- CO2	NBio- CO2	Total CO2	CH4	N2O	CO2e
Category	lb/day										lb/day					
Hauling	0.0000	0.0000	0.0000	0.0000	0.0000	0.0000	0.0000	0.0000	0.0000	0.0000		0.0000	0.0000	0.0000		0.0000
Vendor	0.3183	9.9726	3.3771	0.0343	0.9156	0.0122	0.9277	0.2636	0.0116	0.2752		3,671.4007	3,671.4007	0.2096		3,676.6417
Worker	3.3795	2.1338	24.9725	0.0801	8.9533	0.0681	9.0214	2.3745	0.0627	2.4372		7,983.7318	7,983.7318	0.2055		7,988.8683
Total	3.6978	12.1065	28.3496	0.1144	9.8688	0.0803	9.9491	2.6381	0.0743	2.7124		11,655.1325	11,655.1325	0.4151		11,665.5099

Mitigated Construction On-Site

	ROG	NOx	CO	SO2	Fugitive PM10	Exhaust PM10	PM10 Total	Fugitive PM2.5	Exhaust PM2.5	PM2.5 Total	Bio- CO2	NBio- CO2	Total CO2	CH4	N2O	CO2e
Category	lb/day										lb/day					
Off-Road	1.5728	14.3849	16.2440	0.0269		0.6997	0.6997		0.6584	0.6584	0.0000	2,555.2099	2,555.2099	0.6079		2,570.4061
Total	1.5728	14.3849	16.2440	0.0269		0.6997	0.6997		0.6584	0.6584	0.0000	2,555.2099	2,555.2099	0.6079		2,570.4061

Village South Specific Plan (Proposed) - Los Angeles-South Coast County, Winter

3.5 Building Construction - 2023

Mitigated Construction Off-Site

	ROG	NOx	CO	SO2	Fugitive PM10	Exhaust PM10	PM10 Total	Fugitive PM2.5	Exhaust PM2.5	PM2.5 Total	Bio- CO2	NBio- CO2	Total CO2	CH4	N2O	CO2e
Category	lb/day										lb/day					
Hauling	0.0000	0.0000	0.0000	0.0000	0.0000	0.0000	0.0000	0.0000	0.0000	0.0000		0.0000	0.0000	0.0000		0.0000
Vendor	0.3183	9.9726	3.3771	0.0343	0.9156	0.0122	0.9277	0.2636	0.0116	0.2752		3,671.4007	3,671.4007	0.2096		3,676.6417
Worker	3.3795	2.1338	24.9725	0.0801	8.9533	0.0681	9.0214	2.3745	0.0627	2.4372		7,983.7318	7,983.7318	0.2055		7,988.8683
Total	3.6978	12.1065	28.3496	0.1144	9.8688	0.0803	9.9491	2.6381	0.0743	2.7124		11,655.1325	11,655.1325	0.4151		11,665.5099

3.6 Paving - 2023

Unmitigated Construction On-Site

	ROG	NOx	CO	SO2	Fugitive PM10	Exhaust PM10	PM10 Total	Fugitive PM2.5	Exhaust PM2.5	PM2.5 Total	Bio- CO2	NBio- CO2	Total CO2	CH4	N2O	CO2e
Category	lb/day										lb/day					
Off-Road	1.0327	10.1917	14.5842	0.0228		0.5102	0.5102		0.4694	0.4694		2,207.5841	2,207.5841	0.7140		2,225.4336
Paving	0.0000					0.0000	0.0000		0.0000	0.0000			0.0000			0.0000
Total	1.0327	10.1917	14.5842	0.0228		0.5102	0.5102		0.4694	0.4694		2,207.5841	2,207.5841	0.7140		2,225.4336

Village South Specific Plan (Proposed) - Los Angeles-South Coast County, Winter

3.6 Paving - 2023

Unmitigated Construction Off-Site

	ROG	NOx	CO	SO2	Fugitive PM10	Exhaust PM10	PM10 Total	Fugitive PM2.5	Exhaust PM2.5	PM2.5 Total	Bio- CO2	NBio- CO2	Total CO2	CH4	N2O	CO2e
Category	lb/day										lb/day					
Hauling	0.0000	0.0000	0.0000	0.0000	0.0000	0.0000	0.0000	0.0000	0.0000	0.0000		0.0000	0.0000	0.0000		0.0000
Vendor	0.0000	0.0000	0.0000	0.0000	0.0000	0.0000	0.0000	0.0000	0.0000	0.0000		0.0000	0.0000	0.0000		0.0000
Worker	0.0633	0.0400	0.4677	1.5000e-003	0.1677	1.2800e-003	0.1689	0.0445	1.1700e-003	0.0456		149.5081	149.5081	3.8500e-003		149.6043
Total	0.0633	0.0400	0.4677	1.5000e-003	0.1677	1.2800e-003	0.1689	0.0445	1.1700e-003	0.0456		149.5081	149.5081	3.8500e-003		149.6043

Mitigated Construction On-Site

	ROG	NOx	CO	SO2	Fugitive PM10	Exhaust PM10	PM10 Total	Fugitive PM2.5	Exhaust PM2.5	PM2.5 Total	Bio- CO2	NBio- CO2	Total CO2	CH4	N2O	CO2e
Category	lb/day										lb/day					
Off-Road	1.0327	10.1917	14.5842	0.0228		0.5102	0.5102		0.4694	0.4694	0.0000	2,207.5841	2,207.5841	0.7140		2,225.4336
Paving	0.0000					0.0000	0.0000		0.0000	0.0000			0.0000			0.0000
Total	1.0327	10.1917	14.5842	0.0228		0.5102	0.5102		0.4694	0.4694	0.0000	2,207.5841	2,207.5841	0.7140		2,225.4336

Village South Specific Plan (Proposed) - Los Angeles-South Coast County, Winter

3.6 Paving - 2023

Mitigated Construction Off-Site

	ROG	NOx	CO	SO2	Fugitive PM10	Exhaust PM10	PM10 Total	Fugitive PM2.5	Exhaust PM2.5	PM2.5 Total	Bio- CO2	NBio- CO2	Total CO2	CH4	N2O	CO2e
Category	lb/day										lb/day					
Hauling	0.0000	0.0000	0.0000	0.0000	0.0000	0.0000	0.0000	0.0000	0.0000	0.0000		0.0000	0.0000	0.0000		0.0000
Vendor	0.0000	0.0000	0.0000	0.0000	0.0000	0.0000	0.0000	0.0000	0.0000	0.0000		0.0000	0.0000	0.0000		0.0000
Worker	0.0633	0.0400	0.4677	1.5000e-003	0.1677	1.2800e-003	0.1689	0.0445	1.1700e-003	0.0456		149.5081	149.5081	3.8500e-003		149.6043
Total	0.0633	0.0400	0.4677	1.5000e-003	0.1677	1.2800e-003	0.1689	0.0445	1.1700e-003	0.0456		149.5081	149.5081	3.8500e-003		149.6043

3.6 Paving - 2024

Unmitigated Construction On-Site

	ROG	NOx	CO	SO2	Fugitive PM10	Exhaust PM10	PM10 Total	Fugitive PM2.5	Exhaust PM2.5	PM2.5 Total	Bio- CO2	NBio- CO2	Total CO2	CH4	N2O	CO2e
Category	lb/day										lb/day					
Off-Road	0.9882	9.5246	14.6258	0.0228		0.4685	0.4685		0.4310	0.4310		2,207.5472	2,207.5472	0.7140		2,225.3963
Paving	0.0000					0.0000	0.0000		0.0000	0.0000			0.0000			0.0000
Total	0.9882	9.5246	14.6258	0.0228		0.4685	0.4685		0.4310	0.4310		2,207.5472	2,207.5472	0.7140		2,225.3963

Village South Specific Plan (Proposed) - Los Angeles-South Coast County, Winter

3.6 Paving - 2024

Unmitigated Construction Off-Site

	ROG	NOx	CO	SO2	Fugitive PM10	Exhaust PM10	PM10 Total	Fugitive PM2.5	Exhaust PM2.5	PM2.5 Total	Bio- CO2	NBio- CO2	Total CO2	CH4	N2O	CO2e
Category	lb/day										lb/day					
Hauling	0.0000	0.0000	0.0000	0.0000	0.0000	0.0000	0.0000	0.0000	0.0000	0.0000		0.0000	0.0000	0.0000		0.0000
Vendor	0.0000	0.0000	0.0000	0.0000	0.0000	0.0000	0.0000	0.0000	0.0000	0.0000		0.0000	0.0000	0.0000		0.0000
Worker	0.0601	0.0364	0.4354	1.4500e-003	0.1677	1.2600e-003	0.1689	0.0445	1.1600e-003	0.0456		144.8706	144.8706	3.5300e-003		144.9587
Total	0.0601	0.0364	0.4354	1.4500e-003	0.1677	1.2600e-003	0.1689	0.0445	1.1600e-003	0.0456		144.8706	144.8706	3.5300e-003		144.9587

Mitigated Construction On-Site

	ROG	NOx	CO	SO2	Fugitive PM10	Exhaust PM10	PM10 Total	Fugitive PM2.5	Exhaust PM2.5	PM2.5 Total	Bio- CO2	NBio- CO2	Total CO2	CH4	N2O	CO2e
Category	lb/day										lb/day					
Off-Road	0.9882	9.5246	14.6258	0.0228		0.4685	0.4685		0.4310	0.4310	0.0000	2,207.5472	2,207.5472	0.7140		2,225.3963
Paving	0.0000					0.0000	0.0000		0.0000	0.0000			0.0000			0.0000
Total	0.9882	9.5246	14.6258	0.0228		0.4685	0.4685		0.4310	0.4310	0.0000	2,207.5472	2,207.5472	0.7140		2,225.3963

Village South Specific Plan (Proposed) - Los Angeles-South Coast County, Winter

3.6 Paving - 2024

Mitigated Construction Off-Site

	ROG	NOx	CO	SO2	Fugitive PM10	Exhaust PM10	PM10 Total	Fugitive PM2.5	Exhaust PM2.5	PM2.5 Total	Bio- CO2	NBio- CO2	Total CO2	CH4	N2O	CO2e
Category	lb/day										lb/day					
Hauling	0.0000	0.0000	0.0000	0.0000	0.0000	0.0000	0.0000	0.0000	0.0000	0.0000		0.0000	0.0000	0.0000		0.0000
Vendor	0.0000	0.0000	0.0000	0.0000	0.0000	0.0000	0.0000	0.0000	0.0000	0.0000		0.0000	0.0000	0.0000		0.0000
Worker	0.0601	0.0364	0.4354	1.4500e-003	0.1677	1.2600e-003	0.1689	0.0445	1.1600e-003	0.0456		144.8706	144.8706	3.5300e-003		144.9587
Total	0.0601	0.0364	0.4354	1.4500e-003	0.1677	1.2600e-003	0.1689	0.0445	1.1600e-003	0.0456		144.8706	144.8706	3.5300e-003		144.9587

3.7 Architectural Coating - 2024

Unmitigated Construction On-Site

	ROG	NOx	CO	SO2	Fugitive PM10	Exhaust PM10	PM10 Total	Fugitive PM2.5	Exhaust PM2.5	PM2.5 Total	Bio- CO2	NBio- CO2	Total CO2	CH4	N2O	CO2e
Category	lb/day										lb/day					
Archit. Coating	236.4115					0.0000	0.0000		0.0000	0.0000			0.0000			0.0000
Off-Road	0.1808	1.2188	1.8101	2.9700e-003		0.0609	0.0609		0.0609	0.0609		281.4481	281.4481	0.0159		281.8443
Total	236.5923	1.2188	1.8101	2.9700e-003		0.0609	0.0609		0.0609	0.0609		281.4481	281.4481	0.0159		281.8443

Village South Specific Plan (Proposed) - Los Angeles-South Coast County, Winter

3.7 Architectural Coating - 2024

Unmitigated Construction Off-Site

	ROG	NOx	CO	SO2	Fugitive PM10	Exhaust PM10	PM10 Total	Fugitive PM2.5	Exhaust PM2.5	PM2.5 Total	Bio- CO2	NBio- CO2	Total CO2	CH4	N2O	CO2e
Category	lb/day										lb/day					
Hauling	0.0000	0.0000	0.0000	0.0000	0.0000	0.0000	0.0000	0.0000	0.0000	0.0000		0.0000	0.0000	0.0000		0.0000
Vendor	0.0000	0.0000	0.0000	0.0000	0.0000	0.0000	0.0000	0.0000	0.0000	0.0000		0.0000	0.0000	0.0000		0.0000
Worker	0.6406	0.3886	4.6439	0.0155	1.7884	0.0134	1.8018	0.4743	0.0123	0.4866		1,545.2860	1,545.2860	0.0376		1,546.2262
Total	0.6406	0.3886	4.6439	0.0155	1.7884	0.0134	1.8018	0.4743	0.0123	0.4866		1,545.2860	1,545.2860	0.0376		1,546.2262

Mitigated Construction On-Site

	ROG	NOx	CO	SO2	Fugitive PM10	Exhaust PM10	PM10 Total	Fugitive PM2.5	Exhaust PM2.5	PM2.5 Total	Bio- CO2	NBio- CO2	Total CO2	CH4	N2O	CO2e
Category	lb/day										lb/day					
Archit. Coating	236.4115					0.0000	0.0000		0.0000	0.0000			0.0000			0.0000
Off-Road	0.1808	1.2188	1.8101	2.9700e-003		0.0609	0.0609		0.0609	0.0609	0.0000	281.4481	281.4481	0.0159		281.8443
Total	236.5923	1.2188	1.8101	2.9700e-003		0.0609	0.0609		0.0609	0.0609	0.0000	281.4481	281.4481	0.0159		281.8443

Village South Specific Plan (Proposed) - Los Angeles-South Coast County, Winter

3.7 Architectural Coating - 2024

Mitigated Construction Off-Site

	ROG	NOx	CO	SO2	Fugitive PM10	Exhaust PM10	PM10 Total	Fugitive PM2.5	Exhaust PM2.5	PM2.5 Total	Bio- CO2	NBio- CO2	Total CO2	CH4	N2O	CO2e
Category	lb/day										lb/day					
Hauling	0.0000	0.0000	0.0000	0.0000	0.0000	0.0000	0.0000	0.0000	0.0000	0.0000		0.0000	0.0000	0.0000		0.0000
Vendor	0.0000	0.0000	0.0000	0.0000	0.0000	0.0000	0.0000	0.0000	0.0000	0.0000		0.0000	0.0000	0.0000		0.0000
Worker	0.6406	0.3886	4.6439	0.0155	1.7884	0.0134	1.8018	0.4743	0.0123	0.4866		1,545.2860	1,545.2860	0.0376		1,546.2262
Total	0.6406	0.3886	4.6439	0.0155	1.7884	0.0134	1.8018	0.4743	0.0123	0.4866		1,545.2860	1,545.2860	0.0376		1,546.2262

4.0 Operational Detail - Mobile

4.1 Mitigation Measures Mobile

Village South Specific Plan (Proposed) - Los Angeles-South Coast County, Winter

	ROG	NOx	CO	SO2	Fugitive PM10	Exhaust PM10	PM10 Total	Fugitive PM2.5	Exhaust PM2.5	PM2.5 Total	Bio- CO2	NBio- CO2	Total CO2	CH4	N2O	CO2e
Category	lb/day										lb/day					
Mitigated	9.5233	45.9914	110.0422	0.4681	45.9592	0.3373	46.2965	12.2950	0.3132	12.6083		47,917.8005	47,917.8005	2.1953		47,972.6839
Unmitigated	9.5233	45.9914	110.0422	0.4681	45.9592	0.3373	46.2965	12.2950	0.3132	12.6083		47,917.8005	47,917.8005	2.1953		47,972.6839

4.2 Trip Summary Information

Land Use	Average Daily Trip Rate			Unmitigated	Mitigated
	Weekday	Saturday	Sunday	Annual VMT	Annual VMT
Apartments Low Rise	145.75	154.25	154.00	506,227	506,227
Apartments Mid Rise	4,026.75	3,773.25	4075.50	13,660,065	13,660,065
General Office Building	288.45	62.55	31.05	706,812	706,812
High Turnover (Sit Down Restaurant)	2,368.80	2,873.52	2817.72	3,413,937	3,413,937
Hotel	192.00	187.50	160.00	445,703	445,703
Quality Restaurant	501.12	511.92	461.20	707,488	707,488
Regional Shopping Center	528.08	601.44	357.84	1,112,221	1,112,221
Total	8,050.95	8,164.43	8,057.31	20,552,452	20,552,452

4.3 Trip Type Information

Village South Specific Plan (Proposed) - Los Angeles-South Coast County, Winter

Land Use	Miles			Trip %			Trip Purpose %		
	H-W or C-W	H-S or C-C	H-O or C-NW	H-W or C-W	H-S or C-C	H-O or C-NW	Primary	Diverted	Pass-by
Apartments Low Rise	14.70	5.90	8.70	40.20	19.20	40.60	86	11	3
Apartments Mid Rise	14.70	5.90	8.70	40.20	19.20	40.60	86	11	3
General Office Building	16.60	8.40	6.90	33.00	48.00	19.00	77	19	4
High Turnover (Sit Down Restaurant)	16.60	8.40	6.90	8.50	72.50	19.00	37	20	43
Hotel	16.60	8.40	6.90	19.40	61.60	19.00	58	38	4
Quality Restaurant	16.60	8.40	6.90	12.00	69.00	19.00	38	18	44
Regional Shopping Center	16.60	8.40	6.90	16.30	64.70	19.00	54	35	11

4.4 Fleet Mix

Land Use	LDA	LDT1	LDT2	MDV	LHD1	LHD2	MHD	HHD	OBUS	UBUS	MCY	SBUS	MH
Apartments Low Rise	0.543088	0.044216	0.209971	0.116369	0.014033	0.006332	0.021166	0.033577	0.002613	0.001817	0.005285	0.000712	0.000821
Apartments Mid Rise	0.543088	0.044216	0.209971	0.116369	0.014033	0.006332	0.021166	0.033577	0.002613	0.001817	0.005285	0.000712	0.000821
General Office Building	0.543088	0.044216	0.209971	0.116369	0.014033	0.006332	0.021166	0.033577	0.002613	0.001817	0.005285	0.000712	0.000821
High Turnover (Sit Down Restaurant)	0.543088	0.044216	0.209971	0.116369	0.014033	0.006332	0.021166	0.033577	0.002613	0.001817	0.005285	0.000712	0.000821
Hotel	0.543088	0.044216	0.209971	0.116369	0.014033	0.006332	0.021166	0.033577	0.002613	0.001817	0.005285	0.000712	0.000821
Quality Restaurant	0.543088	0.044216	0.209971	0.116369	0.014033	0.006332	0.021166	0.033577	0.002613	0.001817	0.005285	0.000712	0.000821
Regional Shopping Center	0.543088	0.044216	0.209971	0.116369	0.014033	0.006332	0.021166	0.033577	0.002613	0.001817	0.005285	0.000712	0.000821

5.0 Energy Detail

Historical Energy Use: N

5.1 Mitigation Measures Energy

Village South Specific Plan (Proposed) - Los Angeles-South Coast County, Winter

	ROG	NOx	CO	SO2	Fugitive PM10	Exhaust PM10	PM10 Total	Fugitive PM2.5	Exhaust PM2.5	PM2.5 Total	Bio- CO2	NBio- CO2	Total CO2	CH4	N2O	CO2e
Category	lb/day										lb/day					
NaturalGas Mitigated	0.7660	6.7462	4.2573	0.0418		0.5292	0.5292		0.5292	0.5292		8,355.983 2	8,355.983 2	0.1602	0.1532	8,405.638 7
NaturalGas Unmitigated	0.7660	6.7462	4.2573	0.0418		0.5292	0.5292		0.5292	0.5292		8,355.983 2	8,355.983 2	0.1602	0.1532	8,405.638 7

Village South Specific Plan (Proposed) - Los Angeles-South Coast County, Winter

5.2 Energy by Land Use - NaturalGas

Unmitigated

	NaturalGas Use	ROG	NOx	CO	SO2	Fugitive PM10	Exhaust PM10	PM10 Total	Fugitive PM2.5	Exhaust PM2.5	PM2.5 Total	Bio- CO2	NBio- CO2	Total CO2	CH4	N2O	CO2e
Land Use	kBTU/yr	lb/day										lb/day					
Apartments Low Rise	1119.16	0.0121	0.1031	0.0439	6.6000e-004		8.3400e-003	8.3400e-003		8.3400e-003	8.3400e-003		131.6662	131.6662	2.5200e-003	2.4100e-003	132.4486
Apartments Mid Rise	35784.3	0.3859	3.2978	1.4033	0.0211		0.2666	0.2666		0.2666	0.2666		4,209.9164	4,209.9164	0.0807	0.0772	4,234.9339
General Office Building	1283.42	0.0138	0.1258	0.1057	7.5000e-004		9.5600e-003	9.5600e-003		9.5600e-003	9.5600e-003		150.9911	150.9911	2.8900e-003	2.7700e-003	151.8884
High Turnover (Sit Down Restaurant)	22759.9	0.2455	2.2314	1.8743	0.0134		0.1696	0.1696		0.1696	0.1696		2,677.6342	2,677.6342	0.0513	0.0491	2,693.5460
Hotel	4769.72	0.0514	0.4676	0.3928	2.8100e-003		0.0355	0.0355		0.0355	0.0355		561.1436	561.1436	0.0108	0.0103	564.4782
Quality Restaurant	5057.75	0.0545	0.4959	0.4165	2.9800e-003		0.0377	0.0377		0.0377	0.0377		595.0298	595.0298	0.0114	0.0109	598.5658
Regional Shopping Center	251.616	2.7100e-003	0.0247	0.0207	1.5000e-004		1.8700e-003	1.8700e-003		1.8700e-003	1.8700e-003		29.6019	29.6019	5.7000e-004	5.4000e-004	29.7778
Total		0.7660	6.7463	4.2573	0.0418		0.5292	0.5292		0.5292	0.5292		8,355.9832	8,355.9832	0.1602	0.1532	8,405.6387

Village South Specific Plan (Proposed) - Los Angeles-South Coast County, Winter

5.2 Energy by Land Use - NaturalGas

Mitigated

	NaturalGas Use	ROG	NOx	CO	SO2	Fugitive PM10	Exhaust PM10	PM10 Total	Fugitive PM2.5	Exhaust PM2.5	PM2.5 Total	Bio- CO2	NBio- CO2	Total CO2	CH4	N2O	CO2e
Land Use	kBTU/yr	lb/day										lb/day					
Apartments Low Rise	1.11916	0.0121	0.1031	0.0439	6.6000e-004		8.3400e-003	8.3400e-003		8.3400e-003	8.3400e-003		131.6662	131.6662	2.5200e-003	2.4100e-003	132.4486
Apartments Mid Rise	35.7843	0.3859	3.2978	1.4033	0.0211		0.2666	0.2666		0.2666	0.2666		4,209.9164	4,209.9164	0.0807	0.0772	4,234.9339
General Office Building	1.28342	0.0138	0.1258	0.1057	7.5000e-004		9.5600e-003	9.5600e-003		9.5600e-003	9.5600e-003		150.9911	150.9911	2.8900e-003	2.7700e-003	151.8884
High Turnover (Sit Down Restaurant)	22.7599	0.2455	2.2314	1.8743	0.0134		0.1696	0.1696		0.1696	0.1696		2,677.6342	2,677.6342	0.0513	0.0491	2,693.5460
Hotel	4.76972	0.0514	0.4676	0.3928	2.8100e-003		0.0355	0.0355		0.0355	0.0355		561.1436	561.1436	0.0108	0.0103	564.4782
Quality Restaurant	5.05775	0.0545	0.4959	0.4165	2.9800e-003		0.0377	0.0377		0.0377	0.0377		595.0298	595.0298	0.0114	0.0109	598.5658
Regional Shopping Center	0.251616	2.7100e-003	0.0247	0.0207	1.5000e-004		1.8700e-003	1.8700e-003		1.8700e-003	1.8700e-003		29.6019	29.6019	5.7000e-004	5.4000e-004	29.7778
Total		0.7660	6.7463	4.2573	0.0418		0.5292	0.5292		0.5292	0.5292		8,355.9832	8,355.9832	0.1602	0.1532	8,405.6387

6.0 Area Detail

6.1 Mitigation Measures Area

Village South Specific Plan (Proposed) - Los Angeles-South Coast County, Winter

	ROG	NOx	CO	SO2	Fugitive PM10	Exhaust PM10	PM10 Total	Fugitive PM2.5	Exhaust PM2.5	PM2.5 Total	Bio- CO2	NBio- CO2	Total CO2	CH4	N2O	CO2e
Category	lb/day										lb/day					
Mitigated	30.5020	15.0496	88.4430	0.0944		1.5974	1.5974		1.5974	1.5974	0.0000	18,148.5950	18,148.5950	0.4874	0.3300	18,259.1192
Unmitigated	30.5020	15.0496	88.4430	0.0944		1.5974	1.5974		1.5974	1.5974	0.0000	18,148.5950	18,148.5950	0.4874	0.3300	18,259.1192

6.2 Area by SubCategory

Unmitigated

	ROG	NOx	CO	SO2	Fugitive PM10	Exhaust PM10	PM10 Total	Fugitive PM2.5	Exhaust PM2.5	PM2.5 Total	Bio- CO2	NBio- CO2	Total CO2	CH4	N2O	CO2e
SubCategory	lb/day										lb/day					
Architectural Coating	2.2670					0.0000	0.0000		0.0000	0.0000			0.0000			0.0000
Consumer Products	24.1085					0.0000	0.0000		0.0000	0.0000			0.0000			0.0000
Hearth	1.6500	14.1000	6.0000	0.0900		1.1400	1.1400		1.1400	1.1400	0.0000	18,000.0000	18,000.0000	0.3450	0.3300	18,106.9650
Landscaping	2.4766	0.9496	82.4430	4.3600e-003		0.4574	0.4574		0.4574	0.4574		148.5950	148.5950	0.1424		152.1542
Total	30.5020	15.0496	88.4430	0.0944		1.5974	1.5974		1.5974	1.5974	0.0000	18,148.5950	18,148.5950	0.4874	0.3300	18,259.1192

Village South Specific Plan (Proposed) - Los Angeles-South Coast County, Winter

6.2 Area by SubCategory

Mitigated

	ROG	NOx	CO	SO2	Fugitive PM10	Exhaust PM10	PM10 Total	Fugitive PM2.5	Exhaust PM2.5	PM2.5 Total	Bio- CO2	NBio- CO2	Total CO2	CH4	N2O	CO2e
SubCategory	lb/day										lb/day					
Architectural Coating	2.2670					0.0000	0.0000		0.0000	0.0000			0.0000			0.0000
Consumer Products	24.1085					0.0000	0.0000		0.0000	0.0000			0.0000			0.0000
Hearth	1.6500	14.1000	6.0000	0.0900		1.1400	1.1400		1.1400	1.1400	0.0000	18,000.0000	18,000.0000	0.3450	0.3300	18,106.9650
Landscaping	2.4766	0.9496	82.4430	4.3600e-003		0.4574	0.4574		0.4574	0.4574		148.5950	148.5950	0.1424		152.1542
Total	30.5020	15.0496	88.4430	0.0944		1.5974	1.5974		1.5974	1.5974	0.0000	18,148.5950	18,148.5950	0.4874	0.3300	18,259.1192

7.0 Water Detail

7.1 Mitigation Measures Water

8.0 Waste Detail

8.1 Mitigation Measures Waste

9.0 Operational Offroad

Equipment Type	Number	Hours/Day	Days/Year	Horse Power	Load Factor	Fuel Type
----------------	--------	-----------	-----------	-------------	-------------	-----------

10.0 Stationary Equipment

Village South Specific Plan (Proposed) - Los Angeles-South Coast County, Winter

Fire Pumps and Emergency Generators

Equipment Type	Number	Hours/Day	Hours/Year	Horse Power	Load Factor	Fuel Type
----------------	--------	-----------	------------	-------------	-------------	-----------

Boilers

Equipment Type	Number	Heat Input/Day	Heat Input/Year	Boiler Rating	Fuel Type
----------------	--------	----------------	-----------------	---------------	-----------

User Defined Equipment

Equipment Type	Number
----------------	--------

11.0 Vegetation

Village South Specific Plan (Proposed) - Los Angeles-South Coast County, Annual

Village South Specific Plan (Proposed)
Los Angeles-South Coast County, Annual

1.0 Project Characteristics

1.1 Land Usage

Land Uses	Size	Metric	Lot Acreage	Floor Surface Area	Population
General Office Building	45.00	1000sqft	1.03	45,000.00	0
High Turnover (Sit Down Restaurant)	36.00	1000sqft	0.83	36,000.00	0
Hotel	50.00	Room	1.67	72,600.00	0
Quality Restaurant	8.00	1000sqft	0.18	8,000.00	0
Apartments Low Rise	25.00	Dwelling Unit	1.56	25,000.00	72
Apartments Mid Rise	975.00	Dwelling Unit	25.66	975,000.00	2789
Regional Shopping Center	56.00	1000sqft	1.29	56,000.00	0

1.2 Other Project Characteristics

Urbanization	Urban	Wind Speed (m/s)	2.2	Precipitation Freq (Days)	33
Climate Zone	9			Operational Year	2028
Utility Company	Southern California Edison				
CO2 Intensity (lb/MW hr)	702.44	CH4 Intensity (lb/MW hr)	0.029	N2O Intensity (lb/MW hr)	0.006

1.3 User Entered Comments & Non-Default Data

Village South Specific Plan (Proposed) - Los Angeles-South Coast County, Annual

Project Characteristics - Consistent with the DEIR's model.

Land Use - See SWAPE comment regarding residential and retail land uses.

Construction Phase - See SWAPE comment regarding individual construction phase lengths.

Demolition - Consistent with the DEIR's model. See SWAPE comment regarding demolition.

Vehicle Trips - Saturday trips consistent with the DEIR's model. See SWAPE comment regarding weekday and Sunday trips.

Woodstoves - Woodstoves and wood-burning fireplaces consistent with the DEIR's model. See SWAPE comment regarding gas fireplaces.

Energy Use -

Construction Off-road Equipment Mitigation - See SWAPE comment on construction-related mitigation.

Area Mitigation - See SWAPE comment regarding operational mitigation measures.

Water Mitigation - See SWAPE comment regarding operational mitigation measures.

Trips and VMT - Local hire provision

Table Name	Column Name	Default Value	New Value
tblFireplaces	FireplaceWoodMass	1,019.20	0.00
tblFireplaces	FireplaceWoodMass	1,019.20	0.00
tblFireplaces	NumberWood	1.25	0.00
tblFireplaces	NumberWood	48.75	0.00
tblTripsAndVMT	WorkerTripLength	14.70	10.00
tblTripsAndVMT	WorkerTripLength	14.70	10.00
tblTripsAndVMT	WorkerTripLength	14.70	10.00
tblTripsAndVMT	WorkerTripLength	14.70	10.00
tblTripsAndVMT	WorkerTripLength	14.70	10.00
tblTripsAndVMT	WorkerTripLength	14.70	10.00
tblVehicleTrips	ST_TR	7.16	6.17
tblVehicleTrips	ST_TR	6.39	3.87
tblVehicleTrips	ST_TR	2.46	1.39
tblVehicleTrips	ST_TR	158.37	79.82

Village South Specific Plan (Proposed) - Los Angeles-South Coast County, Annual

tblVehicleTrips	ST_TR	8.19	3.75
tblVehicleTrips	ST_TR	94.36	63.99
tblVehicleTrips	ST_TR	49.97	10.74
tblVehicleTrips	SU_TR	6.07	6.16
tblVehicleTrips	SU_TR	5.86	4.18
tblVehicleTrips	SU_TR	1.05	0.69
tblVehicleTrips	SU_TR	131.84	78.27
tblVehicleTrips	SU_TR	5.95	3.20
tblVehicleTrips	SU_TR	72.16	57.65
tblVehicleTrips	SU_TR	25.24	6.39
tblVehicleTrips	WD_TR	6.59	5.83
tblVehicleTrips	WD_TR	6.65	4.13
tblVehicleTrips	WD_TR	11.03	6.41
tblVehicleTrips	WD_TR	127.15	65.80
tblVehicleTrips	WD_TR	8.17	3.84
tblVehicleTrips	WD_TR	89.95	62.64
tblVehicleTrips	WD_TR	42.70	9.43
tblWoodstoves	NumberCatalytic	1.25	0.00
tblWoodstoves	NumberCatalytic	48.75	0.00
tblWoodstoves	NumberNoncatalytic	1.25	0.00
tblWoodstoves	NumberNoncatalytic	48.75	0.00
tblWoodstoves	WoodstoveDayYear	25.00	0.00
tblWoodstoves	WoodstoveDayYear	25.00	0.00
tblWoodstoves	WoodstoveWoodMass	999.60	0.00
tblWoodstoves	WoodstoveWoodMass	999.60	0.00

2.0 Emissions Summary

Village South Specific Plan (Proposed) - Los Angeles-South Coast County, Annual

2.1 Overall Construction

Unmitigated Construction

	ROG	NOx	CO	SO2	Fugitive PM10	Exhaust PM10	PM10 Total	Fugitive PM2.5	Exhaust PM2.5	PM2.5 Total	Bio- CO2	NBio- CO2	Total CO2	CH4	N2O	CO2e
Year	tons/yr										MT/yr					
2021	0.1704	1.8234	1.1577	2.3800e-003	0.4141	0.0817	0.4958	0.1788	0.0754	0.2542	0.0000	210.7654	210.7654	0.0600	0.0000	212.2661
2022	0.5865	4.0240	5.1546	0.0155	0.9509	0.1175	1.0683	0.2518	0.1103	0.3621	0.0000	1,418.6554	1,418.6554	0.1215	0.0000	1,421.6925
2023	0.5190	3.2850	4.7678	0.0147	0.8497	0.0971	0.9468	0.2283	0.0912	0.3195	0.0000	1,342.4412	1,342.4412	0.1115	0.0000	1,345.2291
2024	4.1592	0.1313	0.2557	5.0000e-004	0.0221	6.3900e-003	0.0285	5.8700e-003	5.9700e-003	0.0118	0.0000	44.6355	44.6355	7.8300e-003	0.0000	44.8311
Maximum	4.1592	4.0240	5.1546	0.0155	0.9509	0.1175	1.0683	0.2518	0.1103	0.3621	0.0000	1,418.6554	1,418.6554	0.1215	0.0000	1,421.6925

Village South Specific Plan (Proposed) - Los Angeles-South Coast County, Annual

2.1 Overall Construction

Mitigated Construction

	ROG	NOx	CO	SO2	Fugitive PM10	Exhaust PM10	PM10 Total	Fugitive PM2.5	Exhaust PM2.5	PM2.5 Total	Bio- CO2	NBio- CO2	Total CO2	CH4	N2O	CO2e
Year	tons/yr										MT/yr					
2021	0.1704	1.8234	1.1577	2.3800e-003	0.4141	0.0817	0.4958	0.1788	0.0754	0.2542	0.0000	210.7651	210.7651	0.0600	0.0000	212.2658
2022	0.5865	4.0240	5.1546	0.0155	0.9509	0.1175	1.0683	0.2518	0.1103	0.3621	0.0000	1,418.6550	1,418.6550	0.1215	0.0000	1,421.6921
2023	0.5190	3.2850	4.7678	0.0147	0.8497	0.0971	0.9468	0.2283	0.0912	0.3195	0.0000	1,342.4409	1,342.4409	0.1115	0.0000	1,345.2287
2024	4.1592	0.1313	0.2557	5.0000e-004	0.0221	6.3900e-003	0.0285	5.8700e-003	5.9700e-003	0.0118	0.0000	44.6354	44.6354	7.8300e-003	0.0000	44.8311
Maximum	4.1592	4.0240	5.1546	0.0155	0.9509	0.1175	1.0683	0.2518	0.1103	0.3621	0.0000	1,418.6550	1,418.6550	0.1215	0.0000	1,421.6921

	ROG	NOx	CO	SO2	Fugitive PM10	Exhaust PM10	PM10 Total	Fugitive PM2.5	Exhaust PM2.5	PM2.5 Total	Bio- CO2	NBio- CO2	Total CO2	CH4	N2O	CO2e
Percent Reduction	0.00	0.00	0.00	0.00	0.00	0.00	0.00	0.00	0.00	0.00	0.00	0.00	0.00	0.00	0.00	0.00

Quarter	Start Date	End Date	Maximum Unmitigated ROG + NOX (tons/quarter)	Maximum Mitigated ROG + NOX (tons/quarter)
1	9-1-2021	11-30-2021	1.4091	1.4091
2	12-1-2021	2-28-2022	1.3329	1.3329
3	3-1-2022	5-31-2022	1.1499	1.1499
4	6-1-2022	8-31-2022	1.1457	1.1457
5	9-1-2022	11-30-2022	1.1415	1.1415
6	12-1-2022	2-28-2023	1.0278	1.0278
7	3-1-2023	5-31-2023	0.9868	0.9868
8	6-1-2023	8-31-2023	0.9831	0.9831

Village South Specific Plan (Proposed) - Los Angeles-South Coast County, Annual

9	9-1-2023	11-30-2023	0.9798	0.9798
10	12-1-2023	2-29-2024	2.8757	2.8757
11	3-1-2024	5-31-2024	1.6188	1.6188
		Highest	2.8757	2.8757

2.2 Overall Operational
Unmitigated Operational

	ROG	NOx	CO	SO2	Fugitive PM10	Exhaust PM10	PM10 Total	Fugitive PM2.5	Exhaust PM2.5	PM2.5 Total	Bio- CO2	NBio- CO2	Total CO2	CH4	N2O	CO2e
Category	tons/yr										MT/yr					
Area	5.1437	0.2950	10.3804	1.6700e-003		0.0714	0.0714		0.0714	0.0714	0.0000	220.9670	220.9670	0.0201	3.7400e-003	222.5835
Energy	0.1398	1.2312	0.7770	7.6200e-003		0.0966	0.0966		0.0966	0.0966	0.0000	3,896.0732	3,896.0732	0.1303	0.0468	3,913.2833
Mobile	1.5857	7.9962	19.1834	0.0821	7.7979	0.0580	7.8559	2.0895	0.0539	2.1434	0.0000	7,620.4986	7,620.4986	0.3407	0.0000	7,629.0162
Waste						0.0000	0.0000		0.0000	0.0000	207.8079	0.0000	207.8079	12.2811	0.0000	514.8354
Water						0.0000	0.0000		0.0000	0.0000	29.1632	556.6420	585.8052	3.0183	0.0755	683.7567
Total	6.8692	9.5223	30.3407	0.0914	7.7979	0.2260	8.0240	2.0895	0.2219	2.3114	236.9712	12,294.1807	12,531.1519	15.7904	0.1260	12,963.4751

Village South Specific Plan (Proposed) - Los Angeles-South Coast County, Annual

2.2 Overall Operational

Mitigated Operational

	ROG	NOx	CO	SO2	Fugitive PM10	Exhaust PM10	PM10 Total	Fugitive PM2.5	Exhaust PM2.5	PM2.5 Total	Bio- CO2	NBio- CO2	Total CO2	CH4	N2O	CO2e
Category	tons/yr										MT/yr					
Area	5.1437	0.2950	10.3804	1.6700e-003		0.0714	0.0714		0.0714	0.0714	0.0000	220.9670	220.9670	0.0201	3.7400e-003	222.5835
Energy	0.1398	1.2312	0.7770	7.6200e-003		0.0966	0.0966		0.0966	0.0966	0.0000	3,896.0732	3,896.0732	0.1303	0.0468	3,913.2833
Mobile	1.5857	7.9962	19.1834	0.0821	7.7979	0.0580	7.8559	2.0895	0.0539	2.1434	0.0000	7,620.4986	7,620.4986	0.3407	0.0000	7,629.0162
Waste						0.0000	0.0000		0.0000	0.0000	207.8079	0.0000	207.8079	12.2811	0.0000	514.8354
Water						0.0000	0.0000		0.0000	0.0000	29.1632	556.6420	585.8052	3.0183	0.0755	683.7567
Total	6.8692	9.5223	30.3407	0.0914	7.7979	0.2260	8.0240	2.0895	0.2219	2.3114	236.9712	12,294.1807	12,531.1519	15.7904	0.1260	12,963.4751

	ROG	NOx	CO	SO2	Fugitive PM10	Exhaust PM10	PM10 Total	Fugitive PM2.5	Exhaust PM2.5	PM2.5 Total	Bio- CO2	NBio- CO2	Total CO2	CH4	N2O	CO2e
Percent Reduction	0.00	0.00	0.00	0.00	0.00	0.00	0.00	0.00	0.00	0.00	0.00	0.00	0.00	0.00	0.00	0.00

3.0 Construction Detail

Construction Phase

Village South Specific Plan (Proposed) - Los Angeles-South Coast County, Annual

Phase Number	Phase Name	Phase Type	Start Date	End Date	Num Days Week	Num Days	Phase Description
1	Demolition	Demolition	9/1/2021	10/12/2021	5	30	
2	Site Preparation	Site Preparation	10/13/2021	11/9/2021	5	20	
3	Grading	Grading	11/10/2021	1/11/2022	5	45	
4	Building Construction	Building Construction	1/12/2022	12/12/2023	5	500	
5	Paving	Paving	12/13/2023	1/30/2024	5	35	
6	Architectural Coating	Architectural Coating	1/31/2024	3/19/2024	5	35	

Acres of Grading (Site Preparation Phase): 0

Acres of Grading (Grading Phase): 112.5

Acres of Paving: 0

Residential Indoor: 2,025,000; Residential Outdoor: 675,000; Non-Residential Indoor: 326,400; Non-Residential Outdoor: 108,800; Striped Parking Area: 0 (Architectural Coating – sqft)

OffRoad Equipment

Village South Specific Plan (Proposed) - Los Angeles-South Coast County, Annual

Phase Name	Offroad Equipment Type	Amount	Usage Hours	Horse Power	Load Factor
Demolition	Concrete/Industrial Saws	1	8.00	81	0.73
Demolition	Excavators	3	8.00	158	0.38
Demolition	Rubber Tired Dozers	2	8.00	247	0.40
Site Preparation	Rubber Tired Dozers	3	8.00	247	0.40
Site Preparation	Tractors/Loaders/Backhoes	4	8.00	97	0.37
Grading	Excavators	2	8.00	158	0.38
Grading	Graders	1	8.00	187	0.41
Grading	Rubber Tired Dozers	1	8.00	247	0.40
Grading	Scrapers	2	8.00	367	0.48
Grading	Tractors/Loaders/Backhoes	2	8.00	97	0.37
Building Construction	Cranes	1	7.00	231	0.29
Building Construction	Forklifts	3	8.00	89	0.20
Building Construction	Generator Sets	1	8.00	84	0.74
Building Construction	Tractors/Loaders/Backhoes	3	7.00	97	0.37
Building Construction	Welders	1	8.00	46	0.45
Paving	Pavers	2	8.00	130	0.42
Paving	Paving Equipment	2	8.00	132	0.36
Paving	Rollers	2	8.00	80	0.38
Architectural Coating	Air Compressors	1	6.00	78	0.48

Trips and VMT

Village South Specific Plan (Proposed) - Los Angeles-South Coast County, Annual

Phase Name	Offroad Equipment Count	Worker Trip Number	Vendor Trip Number	Hauling Trip Number	Worker Trip Length	Vendor Trip Length	Hauling Trip Length	Worker Vehicle Class	Vendor Vehicle Class	Hauling Vehicle Class
Demolition	6	15.00	0.00	458.00	10.00	6.90	20.00	LD_Mix	HDT_Mix	HHDT
Site Preparation	7	18.00	0.00	0.00	10.00	6.90	20.00	LD_Mix	HDT_Mix	HHDT
Grading	8	20.00	0.00	0.00	10.00	6.90	20.00	LD_Mix	HDT_Mix	HHDT
Building Construction	9	801.00	143.00	0.00	10.00	6.90	20.00	LD_Mix	HDT_Mix	HHDT
Paving	6	15.00	0.00	0.00	10.00	6.90	20.00	LD_Mix	HDT_Mix	HHDT
Architectural Coating	1	160.00	0.00	0.00	10.00	6.90	20.00	LD_Mix	HDT_Mix	HHDT

3.1 Mitigation Measures Construction

3.2 Demolition - 2021

Unmitigated Construction On-Site

	ROG	NOx	CO	SO2	Fugitive PM10	Exhaust PM10	PM10 Total	Fugitive PM2.5	Exhaust PM2.5	PM2.5 Total	Bio- CO2	NBio- CO2	Total CO2	CH4	N2O	CO2e
Category	tons/yr										MT/yr					
Fugitive Dust					0.0496	0.0000	0.0496	7.5100e-003	0.0000	7.5100e-003	0.0000	0.0000	0.0000	0.0000	0.0000	0.0000
Off-Road	0.0475	0.4716	0.3235	5.8000e-004		0.0233	0.0233		0.0216	0.0216	0.0000	51.0012	51.0012	0.0144	0.0000	51.3601
Total	0.0475	0.4716	0.3235	5.8000e-004	0.0496	0.0233	0.0729	7.5100e-003	0.0216	0.0291	0.0000	51.0012	51.0012	0.0144	0.0000	51.3601

Village South Specific Plan (Proposed) - Los Angeles-South Coast County, Annual

3.2 Demolition - 2021

Unmitigated Construction Off-Site

	ROG	NOx	CO	SO2	Fugitive PM10	Exhaust PM10	PM10 Total	Fugitive PM2.5	Exhaust PM2.5	PM2.5 Total	Bio- CO2	NBio- CO2	Total CO2	CH4	N2O	CO2e
Category	tons/yr										MT/yr					
Hauling	1.9300e-003	0.0634	0.0148	1.8000e-004	3.9400e-003	1.9000e-004	4.1300e-003	1.0800e-003	1.8000e-004	1.2600e-003	0.0000	17.4566	17.4566	1.2100e-003	0.0000	17.4869
Vendor	0.0000	0.0000	0.0000	0.0000	0.0000	0.0000	0.0000	0.0000	0.0000	0.0000	0.0000	0.0000	0.0000	0.0000	0.0000	0.0000
Worker	7.2000e-004	5.3000e-004	6.0900e-003	2.0000e-005	1.6800e-003	1.0000e-005	1.6900e-003	4.5000e-004	1.0000e-005	4.6000e-004	0.0000	1.5281	1.5281	5.0000e-005	0.0000	1.5293
Total	2.6500e-003	0.0639	0.0209	2.0000e-004	5.6200e-003	2.0000e-004	5.8200e-003	1.5300e-003	1.9000e-004	1.7200e-003	0.0000	18.9847	18.9847	1.2600e-003	0.0000	19.0161

Mitigated Construction On-Site

	ROG	NOx	CO	SO2	Fugitive PM10	Exhaust PM10	PM10 Total	Fugitive PM2.5	Exhaust PM2.5	PM2.5 Total	Bio- CO2	NBio- CO2	Total CO2	CH4	N2O	CO2e
Category	tons/yr										MT/yr					
Fugitive Dust					0.0496	0.0000	0.0496	7.5100e-003	0.0000	7.5100e-003	0.0000	0.0000	0.0000	0.0000	0.0000	0.0000
Off-Road	0.0475	0.4716	0.3235	5.8000e-004		0.0233	0.0233		0.0216	0.0216	0.0000	51.0011	51.0011	0.0144	0.0000	51.3600
Total	0.0475	0.4716	0.3235	5.8000e-004	0.0496	0.0233	0.0729	7.5100e-003	0.0216	0.0291	0.0000	51.0011	51.0011	0.0144	0.0000	51.3600

Village South Specific Plan (Proposed) - Los Angeles-South Coast County, Annual

3.2 Demolition - 2021

Mitigated Construction Off-Site

	ROG	NOx	CO	SO2	Fugitive PM10	Exhaust PM10	PM10 Total	Fugitive PM2.5	Exhaust PM2.5	PM2.5 Total	Bio- CO2	NBio- CO2	Total CO2	CH4	N2O	CO2e
Category	tons/yr										MT/yr					
Hauling	1.9300e-003	0.0634	0.0148	1.8000e-004	3.9400e-003	1.9000e-004	4.1300e-003	1.0800e-003	1.8000e-004	1.2600e-003	0.0000	17.4566	17.4566	1.2100e-003	0.0000	17.4869
Vendor	0.0000	0.0000	0.0000	0.0000	0.0000	0.0000	0.0000	0.0000	0.0000	0.0000	0.0000	0.0000	0.0000	0.0000	0.0000	0.0000
Worker	7.2000e-004	5.3000e-004	6.0900e-003	2.0000e-005	1.6800e-003	1.0000e-005	1.6900e-003	4.5000e-004	1.0000e-005	4.6000e-004	0.0000	1.5281	1.5281	5.0000e-005	0.0000	1.5293
Total	2.6500e-003	0.0639	0.0209	2.0000e-004	5.6200e-003	2.0000e-004	5.8200e-003	1.5300e-003	1.9000e-004	1.7200e-003	0.0000	18.9847	18.9847	1.2600e-003	0.0000	19.0161

3.3 Site Preparation - 2021

Unmitigated Construction On-Site

	ROG	NOx	CO	SO2	Fugitive PM10	Exhaust PM10	PM10 Total	Fugitive PM2.5	Exhaust PM2.5	PM2.5 Total	Bio- CO2	NBio- CO2	Total CO2	CH4	N2O	CO2e
Category	tons/yr										MT/yr					
Fugitive Dust					0.1807	0.0000	0.1807	0.0993	0.0000	0.0993	0.0000	0.0000	0.0000	0.0000	0.0000	0.0000
Off-Road	0.0389	0.4050	0.2115	3.8000e-004		0.0204	0.0204		0.0188	0.0188	0.0000	33.4357	33.4357	0.0108	0.0000	33.7061
Total	0.0389	0.4050	0.2115	3.8000e-004	0.1807	0.0204	0.2011	0.0993	0.0188	0.1181	0.0000	33.4357	33.4357	0.0108	0.0000	33.7061

Village South Specific Plan (Proposed) - Los Angeles-South Coast County, Annual

3.3 Site Preparation - 2021

Unmitigated Construction Off-Site

	ROG	NOx	CO	SO2	Fugitive PM10	Exhaust PM10	PM10 Total	Fugitive PM2.5	Exhaust PM2.5	PM2.5 Total	Bio- CO2	NBio- CO2	Total CO2	CH4	N2O	CO2e
Category	tons/yr										MT/yr					
Hauling	0.0000	0.0000	0.0000	0.0000	0.0000	0.0000	0.0000	0.0000	0.0000	0.0000	0.0000	0.0000	0.0000	0.0000	0.0000	0.0000
Vendor	0.0000	0.0000	0.0000	0.0000	0.0000	0.0000	0.0000	0.0000	0.0000	0.0000	0.0000	0.0000	0.0000	0.0000	0.0000	0.0000
Worker	5.8000e-004	4.3000e-004	4.8700e-003	1.0000e-005	1.3400e-003	1.0000e-005	1.3500e-003	3.6000e-004	1.0000e-005	3.7000e-004	0.0000	1.2225	1.2225	4.0000e-005	0.0000	1.2234
Total	5.8000e-004	4.3000e-004	4.8700e-003	1.0000e-005	1.3400e-003	1.0000e-005	1.3500e-003	3.6000e-004	1.0000e-005	3.7000e-004	0.0000	1.2225	1.2225	4.0000e-005	0.0000	1.2234

Mitigated Construction On-Site

	ROG	NOx	CO	SO2	Fugitive PM10	Exhaust PM10	PM10 Total	Fugitive PM2.5	Exhaust PM2.5	PM2.5 Total	Bio- CO2	NBio- CO2	Total CO2	CH4	N2O	CO2e
Category	tons/yr										MT/yr					
Fugitive Dust					0.1807	0.0000	0.1807	0.0993	0.0000	0.0993	0.0000	0.0000	0.0000	0.0000	0.0000	0.0000
Off-Road	0.0389	0.4050	0.2115	3.8000e-004		0.0204	0.0204		0.0188	0.0188	0.0000	33.4357	33.4357	0.0108	0.0000	33.7060
Total	0.0389	0.4050	0.2115	3.8000e-004	0.1807	0.0204	0.2011	0.0993	0.0188	0.1181	0.0000	33.4357	33.4357	0.0108	0.0000	33.7060

Village South Specific Plan (Proposed) - Los Angeles-South Coast County, Annual

3.3 Site Preparation - 2021

Mitigated Construction Off-Site

	ROG	NOx	CO	SO2	Fugitive PM10	Exhaust PM10	PM10 Total	Fugitive PM2.5	Exhaust PM2.5	PM2.5 Total	Bio- CO2	NBio- CO2	Total CO2	CH4	N2O	CO2e
Category	tons/yr										MT/yr					
Hauling	0.0000	0.0000	0.0000	0.0000	0.0000	0.0000	0.0000	0.0000	0.0000	0.0000	0.0000	0.0000	0.0000	0.0000	0.0000	0.0000
Vendor	0.0000	0.0000	0.0000	0.0000	0.0000	0.0000	0.0000	0.0000	0.0000	0.0000	0.0000	0.0000	0.0000	0.0000	0.0000	0.0000
Worker	5.8000e-004	4.3000e-004	4.8700e-003	1.0000e-005	1.3400e-003	1.0000e-005	1.3500e-003	3.6000e-004	1.0000e-005	3.7000e-004	0.0000	1.2225	1.2225	4.0000e-005	0.0000	1.2234
Total	5.8000e-004	4.3000e-004	4.8700e-003	1.0000e-005	1.3400e-003	1.0000e-005	1.3500e-003	3.6000e-004	1.0000e-005	3.7000e-004	0.0000	1.2225	1.2225	4.0000e-005	0.0000	1.2234

3.4 Grading - 2021

Unmitigated Construction On-Site

	ROG	NOx	CO	SO2	Fugitive PM10	Exhaust PM10	PM10 Total	Fugitive PM2.5	Exhaust PM2.5	PM2.5 Total	Bio- CO2	NBio- CO2	Total CO2	CH4	N2O	CO2e
Category	tons/yr										MT/yr					
Fugitive Dust					0.1741	0.0000	0.1741	0.0693	0.0000	0.0693	0.0000	0.0000	0.0000	0.0000	0.0000	0.0000
Off-Road	0.0796	0.8816	0.5867	1.1800e-003		0.0377	0.0377		0.0347	0.0347	0.0000	103.5405	103.5405	0.0335	0.0000	104.3776
Total	0.0796	0.8816	0.5867	1.1800e-003	0.1741	0.0377	0.2118	0.0693	0.0347	0.1040	0.0000	103.5405	103.5405	0.0335	0.0000	104.3776

Village South Specific Plan (Proposed) - Los Angeles-South Coast County, Annual

3.4 Grading - 2021

Unmitigated Construction Off-Site

	ROG	NOx	CO	SO2	Fugitive PM10	Exhaust PM10	PM10 Total	Fugitive PM2.5	Exhaust PM2.5	PM2.5 Total	Bio- CO2	NBio- CO2	Total CO2	CH4	N2O	CO2e
Category	tons/yr										MT/yr					
Hauling	0.0000	0.0000	0.0000	0.0000	0.0000	0.0000	0.0000	0.0000	0.0000	0.0000	0.0000	0.0000	0.0000	0.0000	0.0000	0.0000
Vendor	0.0000	0.0000	0.0000	0.0000	0.0000	0.0000	0.0000	0.0000	0.0000	0.0000	0.0000	0.0000	0.0000	0.0000	0.0000	0.0000
Worker	1.2200e-003	9.0000e-004	0.0103	3.0000e-005	2.8300e-003	2.0000e-005	2.8600e-003	7.5000e-004	2.0000e-005	7.8000e-004	0.0000	2.5808	2.5808	8.0000e-005	0.0000	2.5828
Total	1.2200e-003	9.0000e-004	0.0103	3.0000e-005	2.8300e-003	2.0000e-005	2.8600e-003	7.5000e-004	2.0000e-005	7.8000e-004	0.0000	2.5808	2.5808	8.0000e-005	0.0000	2.5828

Mitigated Construction On-Site

	ROG	NOx	CO	SO2	Fugitive PM10	Exhaust PM10	PM10 Total	Fugitive PM2.5	Exhaust PM2.5	PM2.5 Total	Bio- CO2	NBio- CO2	Total CO2	CH4	N2O	CO2e
Category	tons/yr										MT/yr					
Fugitive Dust					0.1741	0.0000	0.1741	0.0693	0.0000	0.0693	0.0000	0.0000	0.0000	0.0000	0.0000	0.0000
Off-Road	0.0796	0.8816	0.5867	1.1800e-003		0.0377	0.0377		0.0347	0.0347	0.0000	103.5403	103.5403	0.0335	0.0000	104.3775
Total	0.0796	0.8816	0.5867	1.1800e-003	0.1741	0.0377	0.2118	0.0693	0.0347	0.1040	0.0000	103.5403	103.5403	0.0335	0.0000	104.3775

Village South Specific Plan (Proposed) - Los Angeles-South Coast County, Annual

3.4 Grading - 2021

Mitigated Construction Off-Site

	ROG	NOx	CO	SO2	Fugitive PM10	Exhaust PM10	PM10 Total	Fugitive PM2.5	Exhaust PM2.5	PM2.5 Total	Bio- CO2	NBio- CO2	Total CO2	CH4	N2O	CO2e
Category	tons/yr										MT/yr					
Hauling	0.0000	0.0000	0.0000	0.0000	0.0000	0.0000	0.0000	0.0000	0.0000	0.0000	0.0000	0.0000	0.0000	0.0000	0.0000	0.0000
Vendor	0.0000	0.0000	0.0000	0.0000	0.0000	0.0000	0.0000	0.0000	0.0000	0.0000	0.0000	0.0000	0.0000	0.0000	0.0000	0.0000
Worker	1.2200e-003	9.0000e-004	0.0103	3.0000e-005	2.8300e-003	2.0000e-005	2.8600e-003	7.5000e-004	2.0000e-005	7.8000e-004	0.0000	2.5808	2.5808	8.0000e-005	0.0000	2.5828
Total	1.2200e-003	9.0000e-004	0.0103	3.0000e-005	2.8300e-003	2.0000e-005	2.8600e-003	7.5000e-004	2.0000e-005	7.8000e-004	0.0000	2.5808	2.5808	8.0000e-005	0.0000	2.5828

3.4 Grading - 2022

Unmitigated Construction On-Site

	ROG	NOx	CO	SO2	Fugitive PM10	Exhaust PM10	PM10 Total	Fugitive PM2.5	Exhaust PM2.5	PM2.5 Total	Bio- CO2	NBio- CO2	Total CO2	CH4	N2O	CO2e
Category	tons/yr										MT/yr					
Fugitive Dust					0.0807	0.0000	0.0807	0.0180	0.0000	0.0180	0.0000	0.0000	0.0000	0.0000	0.0000	0.0000
Off-Road	0.0127	0.1360	0.1017	2.2000e-004		5.7200e-003	5.7200e-003		5.2600e-003	5.2600e-003	0.0000	19.0871	19.0871	6.1700e-003	0.0000	19.2414
Total	0.0127	0.1360	0.1017	2.2000e-004	0.0807	5.7200e-003	0.0865	0.0180	5.2600e-003	0.0233	0.0000	19.0871	19.0871	6.1700e-003	0.0000	19.2414

Village South Specific Plan (Proposed) - Los Angeles-South Coast County, Annual

3.4 Grading - 2022

Unmitigated Construction Off-Site

	ROG	NOx	CO	SO2	Fugitive PM10	Exhaust PM10	PM10 Total	Fugitive PM2.5	Exhaust PM2.5	PM2.5 Total	Bio- CO2	NBio- CO2	Total CO2	CH4	N2O	CO2e
Category	tons/yr										MT/yr					
Hauling	0.0000	0.0000	0.0000	0.0000	0.0000	0.0000	0.0000	0.0000	0.0000	0.0000	0.0000	0.0000	0.0000	0.0000	0.0000	0.0000
Vendor	0.0000	0.0000	0.0000	0.0000	0.0000	0.0000	0.0000	0.0000	0.0000	0.0000	0.0000	0.0000	0.0000	0.0000	0.0000	0.0000
Worker	2.1000e-004	1.5000e-004	1.7400e-003	1.0000e-005	5.2000e-004	0.0000	5.3000e-004	1.4000e-004	0.0000	1.4000e-004	0.0000	0.4587	0.4587	1.0000e-005	0.0000	0.4590
Total	2.1000e-004	1.5000e-004	1.7400e-003	1.0000e-005	5.2000e-004	0.0000	5.3000e-004	1.4000e-004	0.0000	1.4000e-004	0.0000	0.4587	0.4587	1.0000e-005	0.0000	0.4590

Mitigated Construction On-Site

	ROG	NOx	CO	SO2	Fugitive PM10	Exhaust PM10	PM10 Total	Fugitive PM2.5	Exhaust PM2.5	PM2.5 Total	Bio- CO2	NBio- CO2	Total CO2	CH4	N2O	CO2e
Category	tons/yr										MT/yr					
Fugitive Dust					0.0807	0.0000	0.0807	0.0180	0.0000	0.0180	0.0000	0.0000	0.0000	0.0000	0.0000	0.0000
Off-Road	0.0127	0.1360	0.1017	2.2000e-004		5.7200e-003	5.7200e-003		5.2600e-003	5.2600e-003	0.0000	19.0871	19.0871	6.1700e-003	0.0000	19.2414
Total	0.0127	0.1360	0.1017	2.2000e-004	0.0807	5.7200e-003	0.0865	0.0180	5.2600e-003	0.0233	0.0000	19.0871	19.0871	6.1700e-003	0.0000	19.2414

Village South Specific Plan (Proposed) - Los Angeles-South Coast County, Annual

3.4 Grading - 2022

Mitigated Construction Off-Site

	ROG	NOx	CO	SO2	Fugitive PM10	Exhaust PM10	PM10 Total	Fugitive PM2.5	Exhaust PM2.5	PM2.5 Total	Bio- CO2	NBio- CO2	Total CO2	CH4	N2O	CO2e
Category	tons/yr										MT/yr					
Hauling	0.0000	0.0000	0.0000	0.0000	0.0000	0.0000	0.0000	0.0000	0.0000	0.0000	0.0000	0.0000	0.0000	0.0000	0.0000	0.0000
Vendor	0.0000	0.0000	0.0000	0.0000	0.0000	0.0000	0.0000	0.0000	0.0000	0.0000	0.0000	0.0000	0.0000	0.0000	0.0000	0.0000
Worker	2.1000e-004	1.5000e-004	1.7400e-003	1.0000e-005	5.2000e-004	0.0000	5.3000e-004	1.4000e-004	0.0000	1.4000e-004	0.0000	0.4587	0.4587	1.0000e-005	0.0000	0.4590
Total	2.1000e-004	1.5000e-004	1.7400e-003	1.0000e-005	5.2000e-004	0.0000	5.3000e-004	1.4000e-004	0.0000	1.4000e-004	0.0000	0.4587	0.4587	1.0000e-005	0.0000	0.4590

3.5 Building Construction - 2022

Unmitigated Construction On-Site

	ROG	NOx	CO	SO2	Fugitive PM10	Exhaust PM10	PM10 Total	Fugitive PM2.5	Exhaust PM2.5	PM2.5 Total	Bio- CO2	NBio- CO2	Total CO2	CH4	N2O	CO2e
Category	tons/yr										MT/yr					
Off-Road	0.2158	1.9754	2.0700	3.4100e-003		0.1023	0.1023		0.0963	0.0963	0.0000	293.1324	293.1324	0.0702	0.0000	294.8881
Total	0.2158	1.9754	2.0700	3.4100e-003		0.1023	0.1023		0.0963	0.0963	0.0000	293.1324	293.1324	0.0702	0.0000	294.8881

Village South Specific Plan (Proposed) - Los Angeles-South Coast County, Annual

3.5 Building Construction - 2022

Unmitigated Construction Off-Site

	ROG	NOx	CO	SO2	Fugitive PM10	Exhaust PM10	PM10 Total	Fugitive PM2.5	Exhaust PM2.5	PM2.5 Total	Bio- CO2	NBio- CO2	Total CO2	CH4	N2O	CO2e
Category	tons/yr										MT/yr					
Hauling	0.0000	0.0000	0.0000	0.0000	0.0000	0.0000	0.0000	0.0000	0.0000	0.0000	0.0000	0.0000	0.0000	0.0000	0.0000	0.0000
Vendor	0.0527	1.6961	0.4580	4.5500e-003	0.1140	3.1800e-003	0.1171	0.0329	3.0400e-003	0.0359	0.0000	441.9835	441.9835	0.0264	0.0000	442.6435
Worker	0.3051	0.2164	2.5233	7.3500e-003	0.7557	6.2300e-003	0.7619	0.2007	5.7400e-003	0.2065	0.0000	663.9936	663.9936	0.0187	0.0000	664.4604
Total	0.3578	1.9125	2.9812	0.0119	0.8696	9.4100e-003	0.8790	0.2336	8.7800e-003	0.2424	0.0000	1,105.9771	1,105.9771	0.0451	0.0000	1,107.1039

Mitigated Construction On-Site

	ROG	NOx	CO	SO2	Fugitive PM10	Exhaust PM10	PM10 Total	Fugitive PM2.5	Exhaust PM2.5	PM2.5 Total	Bio- CO2	NBio- CO2	Total CO2	CH4	N2O	CO2e
Category	tons/yr										MT/yr					
Off-Road	0.2158	1.9754	2.0700	3.4100e-003		0.1023	0.1023		0.0963	0.0963	0.0000	293.1321	293.1321	0.0702	0.0000	294.8877
Total	0.2158	1.9754	2.0700	3.4100e-003		0.1023	0.1023		0.0963	0.0963	0.0000	293.1321	293.1321	0.0702	0.0000	294.8877

Village South Specific Plan (Proposed) - Los Angeles-South Coast County, Annual

3.5 Building Construction - 2022

Mitigated Construction Off-Site

	ROG	NOx	CO	SO2	Fugitive PM10	Exhaust PM10	PM10 Total	Fugitive PM2.5	Exhaust PM2.5	PM2.5 Total	Bio- CO2	NBio- CO2	Total CO2	CH4	N2O	CO2e
Category	tons/yr										MT/yr					
Hauling	0.0000	0.0000	0.0000	0.0000	0.0000	0.0000	0.0000	0.0000	0.0000	0.0000	0.0000	0.0000	0.0000	0.0000	0.0000	0.0000
Vendor	0.0527	1.6961	0.4580	4.5500e-003	0.1140	3.1800e-003	0.1171	0.0329	3.0400e-003	0.0359	0.0000	441.9835	441.9835	0.0264	0.0000	442.6435
Worker	0.3051	0.2164	2.5233	7.3500e-003	0.7557	6.2300e-003	0.7619	0.2007	5.7400e-003	0.2065	0.0000	663.9936	663.9936	0.0187	0.0000	664.4604
Total	0.3578	1.9125	2.9812	0.0119	0.8696	9.4100e-003	0.8790	0.2336	8.7800e-003	0.2424	0.0000	1,105.9771	1,105.9771	0.0451	0.0000	1,107.1039

3.5 Building Construction - 2023

Unmitigated Construction On-Site

	ROG	NOx	CO	SO2	Fugitive PM10	Exhaust PM10	PM10 Total	Fugitive PM2.5	Exhaust PM2.5	PM2.5 Total	Bio- CO2	NBio- CO2	Total CO2	CH4	N2O	CO2e
Category	tons/yr										MT/yr					
Off-Road	0.1942	1.7765	2.0061	3.3300e-003		0.0864	0.0864		0.0813	0.0813	0.0000	286.2789	286.2789	0.0681	0.0000	287.9814
Total	0.1942	1.7765	2.0061	3.3300e-003		0.0864	0.0864		0.0813	0.0813	0.0000	286.2789	286.2789	0.0681	0.0000	287.9814

Village South Specific Plan (Proposed) - Los Angeles-South Coast County, Annual

3.5 Building Construction - 2023

Unmitigated Construction Off-Site

	ROG	NOx	CO	SO2	Fugitive PM10	Exhaust PM10	PM10 Total	Fugitive PM2.5	Exhaust PM2.5	PM2.5 Total	Bio- CO2	NBio- CO2	Total CO2	CH4	N2O	CO2e
Category	tons/yr										MT/yr					
Hauling	0.0000	0.0000	0.0000	0.0000	0.0000	0.0000	0.0000	0.0000	0.0000	0.0000	0.0000	0.0000	0.0000	0.0000	0.0000	0.0000
Vendor	0.0382	1.2511	0.4011	4.3000e-003	0.1113	1.4600e-003	0.1127	0.0321	1.4000e-003	0.0335	0.0000	417.9930	417.9930	0.0228	0.0000	418.5624
Worker	0.2795	0.1910	2.2635	6.9100e-003	0.7377	5.9100e-003	0.7436	0.1960	5.4500e-003	0.2014	0.0000	624.5363	624.5363	0.0164	0.0000	624.9466
Total	0.3177	1.4420	2.6646	0.0112	0.8490	7.3700e-003	0.8564	0.2281	6.8500e-003	0.2349	0.0000	1,042.5294	1,042.5294	0.0392	0.0000	1,043.5090

Mitigated Construction On-Site

	ROG	NOx	CO	SO2	Fugitive PM10	Exhaust PM10	PM10 Total	Fugitive PM2.5	Exhaust PM2.5	PM2.5 Total	Bio- CO2	NBio- CO2	Total CO2	CH4	N2O	CO2e
Category	tons/yr										MT/yr					
Off-Road	0.1942	1.7765	2.0061	3.3300e-003		0.0864	0.0864		0.0813	0.0813	0.0000	286.2785	286.2785	0.0681	0.0000	287.9811
Total	0.1942	1.7765	2.0061	3.3300e-003		0.0864	0.0864		0.0813	0.0813	0.0000	286.2785	286.2785	0.0681	0.0000	287.9811

Village South Specific Plan (Proposed) - Los Angeles-South Coast County, Annual

3.5 Building Construction - 2023

Mitigated Construction Off-Site

	ROG	NOx	CO	SO2	Fugitive PM10	Exhaust PM10	PM10 Total	Fugitive PM2.5	Exhaust PM2.5	PM2.5 Total	Bio- CO2	NBio- CO2	Total CO2	CH4	N2O	CO2e
Category	tons/yr										MT/yr					
Hauling	0.0000	0.0000	0.0000	0.0000	0.0000	0.0000	0.0000	0.0000	0.0000	0.0000	0.0000	0.0000	0.0000	0.0000	0.0000	0.0000
Vendor	0.0382	1.2511	0.4011	4.3000e-003	0.1113	1.4600e-003	0.1127	0.0321	1.4000e-003	0.0335	0.0000	417.9930	417.9930	0.0228	0.0000	418.5624
Worker	0.2795	0.1910	2.2635	6.9100e-003	0.7377	5.9100e-003	0.7436	0.1960	5.4500e-003	0.2014	0.0000	624.5363	624.5363	0.0164	0.0000	624.9466
Total	0.3177	1.4420	2.6646	0.0112	0.8490	7.3700e-003	0.8564	0.2281	6.8500e-003	0.2349	0.0000	1,042.5294	1,042.5294	0.0392	0.0000	1,043.5090

3.6 Paving - 2023

Unmitigated Construction On-Site

	ROG	NOx	CO	SO2	Fugitive PM10	Exhaust PM10	PM10 Total	Fugitive PM2.5	Exhaust PM2.5	PM2.5 Total	Bio- CO2	NBio- CO2	Total CO2	CH4	N2O	CO2e
Category	tons/yr										MT/yr					
Off-Road	6.7100e-003	0.0663	0.0948	1.5000e-004		3.3200e-003	3.3200e-003		3.0500e-003	3.0500e-003	0.0000	13.0175	13.0175	4.2100e-003	0.0000	13.1227
Paving	0.0000					0.0000	0.0000		0.0000	0.0000	0.0000	0.0000	0.0000	0.0000	0.0000	0.0000
Total	6.7100e-003	0.0663	0.0948	1.5000e-004		3.3200e-003	3.3200e-003		3.0500e-003	3.0500e-003	0.0000	13.0175	13.0175	4.2100e-003	0.0000	13.1227

Village South Specific Plan (Proposed) - Los Angeles-South Coast County, Annual

3.6 Paving - 2023

Unmitigated Construction Off-Site

	ROG	NOx	CO	SO2	Fugitive PM10	Exhaust PM10	PM10 Total	Fugitive PM2.5	Exhaust PM2.5	PM2.5 Total	Bio- CO2	NBio- CO2	Total CO2	CH4	N2O	CO2e
Category	tons/yr										MT/yr					
Hauling	0.0000	0.0000	0.0000	0.0000	0.0000	0.0000	0.0000	0.0000	0.0000	0.0000	0.0000	0.0000	0.0000	0.0000	0.0000	0.0000
Vendor	0.0000	0.0000	0.0000	0.0000	0.0000	0.0000	0.0000	0.0000	0.0000	0.0000	0.0000	0.0000	0.0000	0.0000	0.0000	0.0000
Worker	2.8000e-004	1.9000e-004	2.2300e-003	1.0000e-005	7.3000e-004	1.0000e-005	7.3000e-004	1.9000e-004	1.0000e-005	2.0000e-004	0.0000	0.6156	0.6156	2.0000e-005	0.0000	0.6160
Total	2.8000e-004	1.9000e-004	2.2300e-003	1.0000e-005	7.3000e-004	1.0000e-005	7.3000e-004	1.9000e-004	1.0000e-005	2.0000e-004	0.0000	0.6156	0.6156	2.0000e-005	0.0000	0.6160

Mitigated Construction On-Site

	ROG	NOx	CO	SO2	Fugitive PM10	Exhaust PM10	PM10 Total	Fugitive PM2.5	Exhaust PM2.5	PM2.5 Total	Bio- CO2	NBio- CO2	Total CO2	CH4	N2O	CO2e
Category	tons/yr										MT/yr					
Off-Road	6.7100e-003	0.0663	0.0948	1.5000e-004		3.3200e-003	3.3200e-003		3.0500e-003	3.0500e-003	0.0000	13.0175	13.0175	4.2100e-003	0.0000	13.1227
Paving	0.0000					0.0000	0.0000		0.0000	0.0000	0.0000	0.0000	0.0000	0.0000	0.0000	0.0000
Total	6.7100e-003	0.0663	0.0948	1.5000e-004		3.3200e-003	3.3200e-003		3.0500e-003	3.0500e-003	0.0000	13.0175	13.0175	4.2100e-003	0.0000	13.1227

Village South Specific Plan (Proposed) - Los Angeles-South Coast County, Annual

3.6 Paving - 2023

Mitigated Construction Off-Site

	ROG	NOx	CO	SO2	Fugitive PM10	Exhaust PM10	PM10 Total	Fugitive PM2.5	Exhaust PM2.5	PM2.5 Total	Bio- CO2	NBio- CO2	Total CO2	CH4	N2O	CO2e
Category	tons/yr										MT/yr					
Hauling	0.0000	0.0000	0.0000	0.0000	0.0000	0.0000	0.0000	0.0000	0.0000	0.0000	0.0000	0.0000	0.0000	0.0000	0.0000	0.0000
Vendor	0.0000	0.0000	0.0000	0.0000	0.0000	0.0000	0.0000	0.0000	0.0000	0.0000	0.0000	0.0000	0.0000	0.0000	0.0000	0.0000
Worker	2.8000e-004	1.9000e-004	2.2300e-003	1.0000e-005	7.3000e-004	1.0000e-005	7.3000e-004	1.9000e-004	1.0000e-005	2.0000e-004	0.0000	0.6156	0.6156	2.0000e-005	0.0000	0.6160
Total	2.8000e-004	1.9000e-004	2.2300e-003	1.0000e-005	7.3000e-004	1.0000e-005	7.3000e-004	1.9000e-004	1.0000e-005	2.0000e-004	0.0000	0.6156	0.6156	2.0000e-005	0.0000	0.6160

3.6 Paving - 2024

Unmitigated Construction On-Site

	ROG	NOx	CO	SO2	Fugitive PM10	Exhaust PM10	PM10 Total	Fugitive PM2.5	Exhaust PM2.5	PM2.5 Total	Bio- CO2	NBio- CO2	Total CO2	CH4	N2O	CO2e
Category	tons/yr										MT/yr					
Off-Road	0.0109	0.1048	0.1609	2.5000e-004		5.1500e-003	5.1500e-003		4.7400e-003	4.7400e-003	0.0000	22.0292	22.0292	7.1200e-003	0.0000	22.2073
Paving	0.0000					0.0000	0.0000		0.0000	0.0000	0.0000	0.0000	0.0000	0.0000	0.0000	0.0000
Total	0.0109	0.1048	0.1609	2.5000e-004		5.1500e-003	5.1500e-003		4.7400e-003	4.7400e-003	0.0000	22.0292	22.0292	7.1200e-003	0.0000	22.2073

Village South Specific Plan (Proposed) - Los Angeles-South Coast County, Annual

3.6 Paving - 2024

Unmitigated Construction Off-Site

	ROG	NOx	CO	SO2	Fugitive PM10	Exhaust PM10	PM10 Total	Fugitive PM2.5	Exhaust PM2.5	PM2.5 Total	Bio- CO2	NBio- CO2	Total CO2	CH4	N2O	CO2e
Category	tons/yr										MT/yr					
Hauling	0.0000	0.0000	0.0000	0.0000	0.0000	0.0000	0.0000	0.0000	0.0000	0.0000	0.0000	0.0000	0.0000	0.0000	0.0000	0.0000
Vendor	0.0000	0.0000	0.0000	0.0000	0.0000	0.0000	0.0000	0.0000	0.0000	0.0000	0.0000	0.0000	0.0000	0.0000	0.0000	0.0000
Worker	4.4000e-004	2.9000e-004	3.5100e-003	1.0000e-005	1.2300e-003	1.0000e-005	1.2400e-003	3.3000e-004	1.0000e-005	3.4000e-004	0.0000	1.0094	1.0094	3.0000e-005	0.0000	1.0100
Total	4.4000e-004	2.9000e-004	3.5100e-003	1.0000e-005	1.2300e-003	1.0000e-005	1.2400e-003	3.3000e-004	1.0000e-005	3.4000e-004	0.0000	1.0094	1.0094	3.0000e-005	0.0000	1.0100

Mitigated Construction On-Site

	ROG	NOx	CO	SO2	Fugitive PM10	Exhaust PM10	PM10 Total	Fugitive PM2.5	Exhaust PM2.5	PM2.5 Total	Bio- CO2	NBio- CO2	Total CO2	CH4	N2O	CO2e
Category	tons/yr										MT/yr					
Off-Road	0.0109	0.1048	0.1609	2.5000e-004		5.1500e-003	5.1500e-003		4.7400e-003	4.7400e-003	0.0000	22.0292	22.0292	7.1200e-003	0.0000	22.2073
Paving	0.0000					0.0000	0.0000		0.0000	0.0000	0.0000	0.0000	0.0000	0.0000	0.0000	0.0000
Total	0.0109	0.1048	0.1609	2.5000e-004		5.1500e-003	5.1500e-003		4.7400e-003	4.7400e-003	0.0000	22.0292	22.0292	7.1200e-003	0.0000	22.2073

Village South Specific Plan (Proposed) - Los Angeles-South Coast County, Annual

3.6 Paving - 2024

Mitigated Construction Off-Site

	ROG	NOx	CO	SO2	Fugitive PM10	Exhaust PM10	PM10 Total	Fugitive PM2.5	Exhaust PM2.5	PM2.5 Total	Bio- CO2	NBio- CO2	Total CO2	CH4	N2O	CO2e
Category	tons/yr										MT/yr					
Hauling	0.0000	0.0000	0.0000	0.0000	0.0000	0.0000	0.0000	0.0000	0.0000	0.0000	0.0000	0.0000	0.0000	0.0000	0.0000	0.0000
Vendor	0.0000	0.0000	0.0000	0.0000	0.0000	0.0000	0.0000	0.0000	0.0000	0.0000	0.0000	0.0000	0.0000	0.0000	0.0000	0.0000
Worker	4.4000e-004	2.9000e-004	3.5100e-003	1.0000e-005	1.2300e-003	1.0000e-005	1.2400e-003	3.3000e-004	1.0000e-005	3.4000e-004	0.0000	1.0094	1.0094	3.0000e-005	0.0000	1.0100
Total	4.4000e-004	2.9000e-004	3.5100e-003	1.0000e-005	1.2300e-003	1.0000e-005	1.2400e-003	3.3000e-004	1.0000e-005	3.4000e-004	0.0000	1.0094	1.0094	3.0000e-005	0.0000	1.0100

3.7 Architectural Coating - 2024

Unmitigated Construction On-Site

	ROG	NOx	CO	SO2	Fugitive PM10	Exhaust PM10	PM10 Total	Fugitive PM2.5	Exhaust PM2.5	PM2.5 Total	Bio- CO2	NBio- CO2	Total CO2	CH4	N2O	CO2e
Category	tons/yr										MT/yr					
Archit. Coating	4.1372					0.0000	0.0000		0.0000	0.0000	0.0000	0.0000	0.0000	0.0000	0.0000	0.0000
Off-Road	3.1600e-003	0.0213	0.0317	5.0000e-005		1.0700e-003	1.0700e-003		1.0700e-003	1.0700e-003	0.0000	4.4682	4.4682	2.5000e-004	0.0000	4.4745
Total	4.1404	0.0213	0.0317	5.0000e-005		1.0700e-003	1.0700e-003		1.0700e-003	1.0700e-003	0.0000	4.4682	4.4682	2.5000e-004	0.0000	4.4745

Village South Specific Plan (Proposed) - Los Angeles-South Coast County, Annual

3.7 Architectural Coating - 2024

Unmitigated Construction Off-Site

	ROG	NOx	CO	SO2	Fugitive PM10	Exhaust PM10	PM10 Total	Fugitive PM2.5	Exhaust PM2.5	PM2.5 Total	Bio- CO2	NBio- CO2	Total CO2	CH4	N2O	CO2e
Category	tons/yr										MT/yr					
Hauling	0.0000	0.0000	0.0000	0.0000	0.0000	0.0000	0.0000	0.0000	0.0000	0.0000	0.0000	0.0000	0.0000	0.0000	0.0000	0.0000
Vendor	0.0000	0.0000	0.0000	0.0000	0.0000	0.0000	0.0000	0.0000	0.0000	0.0000	0.0000	0.0000	0.0000	0.0000	0.0000	0.0000
Worker	7.4800e-003	4.9300e-003	0.0596	1.9000e-004	0.0209	1.6000e-004	0.0211	5.5500e-003	1.5000e-004	5.7000e-003	0.0000	17.1287	17.1287	4.3000e-004	0.0000	17.1394
Total	7.4800e-003	4.9300e-003	0.0596	1.9000e-004	0.0209	1.6000e-004	0.0211	5.5500e-003	1.5000e-004	5.7000e-003	0.0000	17.1287	17.1287	4.3000e-004	0.0000	17.1394

Mitigated Construction On-Site

	ROG	NOx	CO	SO2	Fugitive PM10	Exhaust PM10	PM10 Total	Fugitive PM2.5	Exhaust PM2.5	PM2.5 Total	Bio- CO2	NBio- CO2	Total CO2	CH4	N2O	CO2e
Category	tons/yr										MT/yr					
Archit. Coating	4.1372					0.0000	0.0000		0.0000	0.0000	0.0000	0.0000	0.0000	0.0000	0.0000	0.0000
Off-Road	3.1600e-003	0.0213	0.0317	5.0000e-005		1.0700e-003	1.0700e-003		1.0700e-003	1.0700e-003	0.0000	4.4682	4.4682	2.5000e-004	0.0000	4.4745
Total	4.1404	0.0213	0.0317	5.0000e-005		1.0700e-003	1.0700e-003		1.0700e-003	1.0700e-003	0.0000	4.4682	4.4682	2.5000e-004	0.0000	4.4745

Village South Specific Plan (Proposed) - Los Angeles-South Coast County, Annual

3.7 Architectural Coating - 2024

Mitigated Construction Off-Site

	ROG	NOx	CO	SO2	Fugitive PM10	Exhaust PM10	PM10 Total	Fugitive PM2.5	Exhaust PM2.5	PM2.5 Total	Bio- CO2	NBio- CO2	Total CO2	CH4	N2O	CO2e
Category	tons/yr										MT/yr					
Hauling	0.0000	0.0000	0.0000	0.0000	0.0000	0.0000	0.0000	0.0000	0.0000	0.0000	0.0000	0.0000	0.0000	0.0000	0.0000	0.0000
Vendor	0.0000	0.0000	0.0000	0.0000	0.0000	0.0000	0.0000	0.0000	0.0000	0.0000	0.0000	0.0000	0.0000	0.0000	0.0000	0.0000
Worker	7.4800e-003	4.9300e-003	0.0596	1.9000e-004	0.0209	1.6000e-004	0.0211	5.5500e-003	1.5000e-004	5.7000e-003	0.0000	17.1287	17.1287	4.3000e-004	0.0000	17.1394
Total	7.4800e-003	4.9300e-003	0.0596	1.9000e-004	0.0209	1.6000e-004	0.0211	5.5500e-003	1.5000e-004	5.7000e-003	0.0000	17.1287	17.1287	4.3000e-004	0.0000	17.1394

4.0 Operational Detail - Mobile

4.1 Mitigation Measures Mobile

Village South Specific Plan (Proposed) - Los Angeles-South Coast County, Annual

	ROG	NOx	CO	SO2	Fugitive PM10	Exhaust PM10	PM10 Total	Fugitive PM2.5	Exhaust PM2.5	PM2.5 Total	Bio- CO2	NBio- CO2	Total CO2	CH4	N2O	CO2e
Category	tons/yr										MT/yr					
Mitigated	1.5857	7.9962	19.1834	0.0821	7.7979	0.0580	7.8559	2.0895	0.0539	2.1434	0.0000	7,620.4986	7,620.4986	0.3407	0.0000	7,629.0162
Unmitigated	1.5857	7.9962	19.1834	0.0821	7.7979	0.0580	7.8559	2.0895	0.0539	2.1434	0.0000	7,620.4986	7,620.4986	0.3407	0.0000	7,629.0162

4.2 Trip Summary Information

Land Use	Average Daily Trip Rate			Unmitigated	Mitigated
	Weekday	Saturday	Sunday	Annual VMT	Annual VMT
Apartments Low Rise	145.75	154.25	154.00	506,227	506,227
Apartments Mid Rise	4,026.75	3,773.25	4075.50	13,660,065	13,660,065
General Office Building	288.45	62.55	31.05	706,812	706,812
High Turnover (Sit Down Restaurant)	2,368.80	2,873.52	2817.72	3,413,937	3,413,937
Hotel	192.00	187.50	160.00	445,703	445,703
Quality Restaurant	501.12	511.92	461.20	707,488	707,488
Regional Shopping Center	528.08	601.44	357.84	1,112,221	1,112,221
Total	8,050.95	8,164.43	8,057.31	20,552,452	20,552,452

4.3 Trip Type Information

Village South Specific Plan (Proposed) - Los Angeles-South Coast County, Annual

Land Use	Miles			Trip %			Trip Purpose %		
	H-W or C-W	H-S or C-C	H-O or C-NW	H-W or C-W	H-S or C-C	H-O or C-NW	Primary	Diverted	Pass-by
Apartments Low Rise	14.70	5.90	8.70	40.20	19.20	40.60	86	11	3
Apartments Mid Rise	14.70	5.90	8.70	40.20	19.20	40.60	86	11	3
General Office Building	16.60	8.40	6.90	33.00	48.00	19.00	77	19	4
High Turnover (Sit Down Restaurant)	16.60	8.40	6.90	8.50	72.50	19.00	37	20	43
Hotel	16.60	8.40	6.90	19.40	61.60	19.00	58	38	4
Quality Restaurant	16.60	8.40	6.90	12.00	69.00	19.00	38	18	44
Regional Shopping Center	16.60	8.40	6.90	16.30	64.70	19.00	54	35	11

4.4 Fleet Mix

Land Use	LDA	LDT1	LDT2	MDV	LHD1	LHD2	MHD	HHD	OBUS	UBUS	MCY	SBUS	MH
Apartments Low Rise	0.543088	0.044216	0.209971	0.116369	0.014033	0.006332	0.021166	0.033577	0.002613	0.001817	0.005285	0.000712	0.000821
Apartments Mid Rise	0.543088	0.044216	0.209971	0.116369	0.014033	0.006332	0.021166	0.033577	0.002613	0.001817	0.005285	0.000712	0.000821
General Office Building	0.543088	0.044216	0.209971	0.116369	0.014033	0.006332	0.021166	0.033577	0.002613	0.001817	0.005285	0.000712	0.000821
High Turnover (Sit Down Restaurant)	0.543088	0.044216	0.209971	0.116369	0.014033	0.006332	0.021166	0.033577	0.002613	0.001817	0.005285	0.000712	0.000821
Hotel	0.543088	0.044216	0.209971	0.116369	0.014033	0.006332	0.021166	0.033577	0.002613	0.001817	0.005285	0.000712	0.000821
Quality Restaurant	0.543088	0.044216	0.209971	0.116369	0.014033	0.006332	0.021166	0.033577	0.002613	0.001817	0.005285	0.000712	0.000821
Regional Shopping Center	0.543088	0.044216	0.209971	0.116369	0.014033	0.006332	0.021166	0.033577	0.002613	0.001817	0.005285	0.000712	0.000821

5.0 Energy Detail

Historical Energy Use: N

5.1 Mitigation Measures Energy

Village South Specific Plan (Proposed) - Los Angeles-South Coast County, Annual

	ROG	NOx	CO	SO2	Fugitive PM10	Exhaust PM10	PM10 Total	Fugitive PM2.5	Exhaust PM2.5	PM2.5 Total	Bio- CO2	NBio- CO2	Total CO2	CH4	N2O	CO2e
Category	tons/yr										MT/yr					
Electricity Mitigated							0.0000	0.0000		0.0000	0.0000	2,512.6465	2,512.6465	0.1037	0.0215	2,521.6356
Electricity Unmitigated							0.0000	0.0000		0.0000	0.0000	2,512.6465	2,512.6465	0.1037	0.0215	2,521.6356
NaturalGas Mitigated	0.1398	1.2312	0.7770	7.6200e-003			0.0966	0.0966		0.0966	0.0000	1,383.4267	1,383.4267	0.0265	0.0254	1,391.6478
NaturalGas Unmitigated	0.1398	1.2312	0.7770	7.6200e-003			0.0966	0.0966		0.0966	0.0000	1,383.4267	1,383.4267	0.0265	0.0254	1,391.6478

Village South Specific Plan (Proposed) - Los Angeles-South Coast County, Annual

5.2 Energy by Land Use - NaturalGas

Unmitigated

	NaturalGas Use	ROG	NOx	CO	SO2	Fugitive PM10	Exhaust PM10	PM10 Total	Fugitive PM2.5	Exhaust PM2.5	PM2.5 Total	Bio- CO2	NBio- CO2	Total CO2	CH4	N2O	CO2e
Land Use	kBTU/yr	tons/yr										MT/yr					
Apartments Low Rise	408494	2.2000e-003	0.0188	8.0100e-003	1.2000e-004		1.5200e-003	1.5200e-003		1.5200e-003	1.5200e-003	0.0000	21.7988	21.7988	4.2000e-004	4.0000e-004	21.9284
Apartments Mid Rise	1.30613e+007	0.0704	0.6018	0.2561	3.8400e-003		0.0487	0.0487		0.0487	0.0487	0.0000	696.9989	696.9989	0.0134	0.0128	701.1408
General Office Building	468450	2.5300e-003	0.0230	0.0193	1.4000e-004		1.7500e-003	1.7500e-003		1.7500e-003	1.7500e-003	0.0000	24.9983	24.9983	4.8000e-004	4.6000e-004	25.1468
High Turnover (Sit Down Restaurant)	8.30736e+006	0.0448	0.4072	0.3421	2.4400e-003		0.0310	0.0310		0.0310	0.0310	0.0000	443.3124	443.3124	8.5000e-003	8.1300e-003	445.9468
Hotel	1.74095e+006	9.3900e-003	0.0853	0.0717	5.1000e-004		6.4900e-003	6.4900e-003		6.4900e-003	6.4900e-003	0.0000	92.9036	92.9036	1.7800e-003	1.7000e-003	93.4557
Quality Restaurant	1.84608e+006	9.9500e-003	0.0905	0.0760	5.4000e-004		6.8800e-003	6.8800e-003		6.8800e-003	6.8800e-003	0.0000	98.5139	98.5139	1.8900e-003	1.8100e-003	99.0993
Regional Shopping Center	91840	5.0000e-004	4.5000e-003	3.7800e-003	3.0000e-005		3.4000e-004	3.4000e-004		3.4000e-004	3.4000e-004	0.0000	4.9009	4.9009	9.0000e-005	9.0000e-005	4.9301
Total		0.1398	1.2312	0.7770	7.6200e-003		0.0966	0.0966		0.0966	0.0966	0.0000	1,383.4268	1,383.4268	0.0265	0.0254	1,391.6478

Village South Specific Plan (Proposed) - Los Angeles-South Coast County, Annual

5.2 Energy by Land Use - NaturalGas

Mitigated

	NaturalGas Use	ROG	NOx	CO	SO2	Fugitive PM10	Exhaust PM10	PM10 Total	Fugitive PM2.5	Exhaust PM2.5	PM2.5 Total	Bio- CO2	NBio- CO2	Total CO2	CH4	N2O	CO2e
Land Use	kBTU/yr	tons/yr										MT/yr					
Apartments Low Rise	408494	2.2000e-003	0.0188	8.0100e-003	1.2000e-004		1.5200e-003	1.5200e-003		1.5200e-003	1.5200e-003	0.0000	21.7988	21.7988	4.2000e-004	4.0000e-004	21.9284
Apartments Mid Rise	1.30613e+007	0.0704	0.6018	0.2561	3.8400e-003		0.0487	0.0487		0.0487	0.0487	0.0000	696.9989	696.9989	0.0134	0.0128	701.1408
General Office Building	468450	2.5300e-003	0.0230	0.0193	1.4000e-004		1.7500e-003	1.7500e-003		1.7500e-003	1.7500e-003	0.0000	24.9983	24.9983	4.8000e-004	4.6000e-004	25.1468
High Turnover (Sit Down Restaurant)	8.30736e+006	0.0448	0.4072	0.3421	2.4400e-003		0.0310	0.0310		0.0310	0.0310	0.0000	443.3124	443.3124	8.5000e-003	8.1300e-003	445.9468
Hotel	1.74095e+006	9.3900e-003	0.0853	0.0717	5.1000e-004		6.4900e-003	6.4900e-003		6.4900e-003	6.4900e-003	0.0000	92.9036	92.9036	1.7800e-003	1.7000e-003	93.4557
Quality Restaurant	1.84608e+006	9.9500e-003	0.0905	0.0760	5.4000e-004		6.8800e-003	6.8800e-003		6.8800e-003	6.8800e-003	0.0000	98.5139	98.5139	1.8900e-003	1.8100e-003	99.0993
Regional Shopping Center	91840	5.0000e-004	4.5000e-003	3.7800e-003	3.0000e-005		3.4000e-004	3.4000e-004		3.4000e-004	3.4000e-004	0.0000	4.9009	4.9009	9.0000e-005	9.0000e-005	4.9301
Total		0.1398	1.2312	0.7770	7.6200e-003		0.0966	0.0966		0.0966	0.0966	0.0000	1,383.4268	1,383.4268	0.0265	0.0254	1,391.6478

Village South Specific Plan (Proposed) - Los Angeles-South Coast County, Annual

5.3 Energy by Land Use - Electricity

Unmitigated

	Electricity Use	Total CO2	CH4	N2O	CO2e
Land Use	kWh/yr	MT/yr			
Apartments Low Rise	106010	33.7770	1.3900e-003	2.9000e-004	33.8978
Apartments Mid Rise	3.94697e+006	1,257.5879	0.0519	0.0107	1,262.0869
General Office Building	584550	186.2502	7.6900e-003	1.5900e-003	186.9165
High Turnover (Sit Down Restaurant)	1.58904e+006	506.3022	0.0209	4.3200e-003	508.1135
Hotel	550308	175.3399	7.2400e-003	1.5000e-003	175.9672
Quality Restaurant	353120	112.5116	4.6500e-003	9.6000e-004	112.9141
Regional Shopping Center	756000	240.8778	9.9400e-003	2.0600e-003	241.7395
Total		2,512.6465	0.1037	0.0215	2,521.6356

Village South Specific Plan (Proposed) - Los Angeles-South Coast County, Annual

5.3 Energy by Land Use - Electricity

Mitigated

	Electricity Use	Total CO2	CH4	N2O	CO2e
Land Use	kWh/yr	MT/yr			
Apartments Low Rise	106010	33.7770	1.3900e-003	2.9000e-004	33.8978
Apartments Mid Rise	3.94697e+006	1,257.5879	0.0519	0.0107	1,262.0869
General Office Building	584550	186.2502	7.6900e-003	1.5900e-003	186.9165
High Turnover (Sit Down Restaurant)	1.58904e+006	506.3022	0.0209	4.3200e-003	508.1135
Hotel	550308	175.3399	7.2400e-003	1.5000e-003	175.9672
Quality Restaurant	353120	112.5116	4.6500e-003	9.6000e-004	112.9141
Regional Shopping Center	756000	240.8778	9.9400e-003	2.0600e-003	241.7395
Total		2,512.6465	0.1037	0.0215	2,521.6356

6.0 Area Detail

6.1 Mitigation Measures Area

Village South Specific Plan (Proposed) - Los Angeles-South Coast County, Annual

	ROG	NOx	CO	SO2	Fugitive PM10	Exhaust PM10	PM10 Total	Fugitive PM2.5	Exhaust PM2.5	PM2.5 Total	Bio- CO2	NBio- CO2	Total CO2	CH4	N2O	CO2e
Category	tons/yr										MT/yr					
Mitigated	5.1437	0.2950	10.3804	1.6700e-003		0.0714	0.0714		0.0714	0.0714	0.0000	220.9670	220.9670	0.0201	3.7400e-003	222.5835
Unmitigated	5.1437	0.2950	10.3804	1.6700e-003		0.0714	0.0714		0.0714	0.0714	0.0000	220.9670	220.9670	0.0201	3.7400e-003	222.5835

6.2 Area by SubCategory

Unmitigated

	ROG	NOx	CO	SO2	Fugitive PM10	Exhaust PM10	PM10 Total	Fugitive PM2.5	Exhaust PM2.5	PM2.5 Total	Bio- CO2	NBio- CO2	Total CO2	CH4	N2O	CO2e
SubCategory	tons/yr										MT/yr					
Architectural Coating	0.4137					0.0000	0.0000		0.0000	0.0000	0.0000	0.0000	0.0000	0.0000	0.0000	0.0000
Consumer Products	4.3998					0.0000	0.0000		0.0000	0.0000	0.0000	0.0000	0.0000	0.0000	0.0000	0.0000
Hearth	0.0206	0.1763	0.0750	1.1200e-003		0.0143	0.0143		0.0143	0.0143	0.0000	204.1166	204.1166	3.9100e-003	3.7400e-003	205.3295
Landscaping	0.3096	0.1187	10.3054	5.4000e-004		0.0572	0.0572		0.0572	0.0572	0.0000	16.8504	16.8504	0.0161	0.0000	17.2540
Total	5.1437	0.2950	10.3804	1.6600e-003		0.0714	0.0714		0.0714	0.0714	0.0000	220.9670	220.9670	0.0201	3.7400e-003	222.5835

Village South Specific Plan (Proposed) - Los Angeles-South Coast County, Annual

6.2 Area by SubCategory

Mitigated

	ROG	NOx	CO	SO2	Fugitive PM10	Exhaust PM10	PM10 Total	Fugitive PM2.5	Exhaust PM2.5	PM2.5 Total	Bio- CO2	NBio- CO2	Total CO2	CH4	N2O	CO2e
SubCategory	tons/yr										MT/yr					
Architectural Coating	0.4137					0.0000	0.0000		0.0000	0.0000	0.0000	0.0000	0.0000	0.0000	0.0000	0.0000
Consumer Products	4.3998					0.0000	0.0000		0.0000	0.0000	0.0000	0.0000	0.0000	0.0000	0.0000	0.0000
Hearth	0.0206	0.1763	0.0750	1.1200e-003		0.0143	0.0143		0.0143	0.0143	0.0000	204.1166	204.1166	3.9100e-003	3.7400e-003	205.3295
Landscaping	0.3096	0.1187	10.3054	5.4000e-004		0.0572	0.0572		0.0572	0.0572	0.0000	16.8504	16.8504	0.0161	0.0000	17.2540
Total	5.1437	0.2950	10.3804	1.6600e-003		0.0714	0.0714		0.0714	0.0714	0.0000	220.9670	220.9670	0.0201	3.7400e-003	222.5835

7.0 Water Detail

7.1 Mitigation Measures Water

Village South Specific Plan (Proposed) - Los Angeles-South Coast County, Annual

	Total CO2	CH4	N2O	CO2e
Category	MT/yr			
Mitigated	585.8052	3.0183	0.0755	683.7567
Unmitigated	585.8052	3.0183	0.0755	683.7567

Village South Specific Plan (Proposed) - Los Angeles-South Coast County, Annual

7.2 Water by Land Use

Unmitigated

	Indoor/Outdoor Use	Total CO2	CH4	N2O	CO2e
Land Use	Mgal	MT/yr			
Apartments Low Rise	1.62885 / 1.02688	10.9095	0.0535	1.3400e-003	12.6471
Apartments Mid Rise	63.5252 / 40.0485	425.4719	2.0867	0.0523	493.2363
General Office Building	7.99802 / 4.90201	53.0719	0.2627	6.5900e-003	61.6019
High Turnover (Sit Down Restaurant)	10.9272 / 0.697482	51.2702	0.3580	8.8200e-003	62.8482
Hotel	1.26834 / 0.140927	6.1633	0.0416	1.0300e-003	7.5079
Quality Restaurant	2.42827 / 0.154996	11.3934	0.0796	1.9600e-003	13.9663
Regional Shopping Center	4.14806 / 2.54236	27.5250	0.1363	3.4200e-003	31.9490
Total		585.8052	3.0183	0.0755	683.7567

Village South Specific Plan (Proposed) - Los Angeles-South Coast County, Annual

7.2 Water by Land Use

Mitigated

	Indoor/Outdoor Use	Total CO2	CH4	N2O	CO2e
Land Use	Mgal	MT/yr			
Apartments Low Rise	1.62885 / 1.02688	10.9095	0.0535	1.3400e-003	12.6471
Apartments Mid Rise	63.5252 / 40.0485	425.4719	2.0867	0.0523	493.2363
General Office Building	7.99802 / 4.90201	53.0719	0.2627	6.5900e-003	61.6019
High Turnover (Sit Down Restaurant)	10.9272 / 0.697482	51.2702	0.3580	8.8200e-003	62.8482
Hotel	1.26834 / 0.140927	6.1633	0.0416	1.0300e-003	7.5079
Quality Restaurant	2.42827 / 0.154996	11.3934	0.0796	1.9600e-003	13.9663
Regional Shopping Center	4.14806 / 2.54236	27.5250	0.1363	3.4200e-003	31.9490
Total		585.8052	3.0183	0.0755	683.7567

8.0 Waste Detail

8.1 Mitigation Measures Waste

Village South Specific Plan (Proposed) - Los Angeles-South Coast County, Annual

Category/Year

	Total CO2	CH4	N2O	CO2e
	MT/yr			
Mitigated	207.8079	12.2811	0.0000	514.8354
Unmitigated	207.8079	12.2811	0.0000	514.8354

Village South Specific Plan (Proposed) - Los Angeles-South Coast County, Annual

8.2 Waste by Land Use

Unmitigated

	Waste Disposed	Total CO2	CH4	N2O	CO2e
Land Use	tons	MT/yr			
Apartments Low Rise	11.5	2.3344	0.1380	0.0000	5.7834
Apartments Mid Rise	448.5	91.0415	5.3804	0.0000	225.5513
General Office Building	41.85	8.4952	0.5021	0.0000	21.0464
High Turnover (Sit Down Restaurant)	428.4	86.9613	5.1393	0.0000	215.4430
Hotel	27.38	5.5579	0.3285	0.0000	13.7694
Quality Restaurant	7.3	1.4818	0.0876	0.0000	3.6712
Regional Shopping Center	58.8	11.9359	0.7054	0.0000	29.5706
Total		207.8079	12.2811	0.0000	514.8354

Village South Specific Plan (Proposed) - Los Angeles-South Coast County, Annual

8.2 Waste by Land Use

Mitigated

	Waste Disposed	Total CO2	CH4	N2O	CO2e
Land Use	tons	MT/yr			
Apartments Low Rise	11.5	2.3344	0.1380	0.0000	5.7834
Apartments Mid Rise	448.5	91.0415	5.3804	0.0000	225.5513
General Office Building	41.85	8.4952	0.5021	0.0000	21.0464
High Turnover (Sit Down Restaurant)	428.4	86.9613	5.1393	0.0000	215.4430
Hotel	27.38	5.5579	0.3285	0.0000	13.7694
Quality Restaurant	7.3	1.4818	0.0876	0.0000	3.6712
Regional Shopping Center	58.8	11.9359	0.7054	0.0000	29.5706
Total		207.8079	12.2811	0.0000	514.8354

9.0 Operational Offroad

Equipment Type	Number	Hours/Day	Days/Year	Horse Power	Load Factor	Fuel Type
----------------	--------	-----------	-----------	-------------	-------------	-----------

10.0 Stationary Equipment

Fire Pumps and Emergency Generators

Equipment Type	Number	Hours/Day	Hours/Year	Horse Power	Load Factor	Fuel Type
----------------	--------	-----------	------------	-------------	-------------	-----------

Village South Specific Plan (Proposed) - Los Angeles-South Coast County, Annual

Boilers

Equipment Type	Number	Heat Input/Day	Heat Input/Year	Boiler Rating	Fuel Type
----------------	--------	----------------	-----------------	---------------	-----------

User Defined Equipment

Equipment Type	Number
----------------	--------

11.0 Vegetation

Village South Specific Plan (Proposed) - Los Angeles-South Coast County, Summer

Village South Specific Plan (Proposed)
Los Angeles-South Coast County, Summer

1.0 Project Characteristics

1.1 Land Usage

Land Uses	Size	Metric	Lot Acreage	Floor Surface Area	Population
General Office Building	45.00	1000sqft	1.03	45,000.00	0
High Turnover (Sit Down Restaurant)	36.00	1000sqft	0.83	36,000.00	0
Hotel	50.00	Room	1.67	72,600.00	0
Quality Restaurant	8.00	1000sqft	0.18	8,000.00	0
Apartments Low Rise	25.00	Dwelling Unit	1.56	25,000.00	72
Apartments Mid Rise	975.00	Dwelling Unit	25.66	975,000.00	2789
Regional Shopping Center	56.00	1000sqft	1.29	56,000.00	0

1.2 Other Project Characteristics

Urbanization	Urban	Wind Speed (m/s)	2.2	Precipitation Freq (Days)	33
Climate Zone	9			Operational Year	2028
Utility Company	Southern California Edison				
CO2 Intensity (lb/MW hr)	702.44	CH4 Intensity (lb/MW hr)	0.029	N2O Intensity (lb/MW hr)	0.006

1.3 User Entered Comments & Non-Default Data

Village South Specific Plan (Proposed) - Los Angeles-South Coast County, Summer

Project Characteristics - Consistent with the DEIR's model.

Land Use - See SWAPE comment regarding residential and retail land uses.

Construction Phase - See SWAPE comment regarding individual construction phase lengths.

Demolition - Consistent with the DEIR's model. See SWAPE comment regarding demolition.

Vehicle Trips - Saturday trips consistent with the DEIR's model. See SWAPE comment regarding weekday and Sunday trips.

Woodstoves - Woodstoves and wood-burning fireplaces consistent with the DEIR's model. See SWAPE comment regarding gas fireplaces.

Energy Use -

Construction Off-road Equipment Mitigation - See SWAPE comment on construction-related mitigation.

Area Mitigation - See SWAPE comment regarding operational mitigation measures.

Water Mitigation - See SWAPE comment regarding operational mitigation measures.

Trips and VMT - Local hire provision

Table Name	Column Name	Default Value	New Value
tblFireplaces	FireplaceWoodMass	1,019.20	0.00
tblFireplaces	FireplaceWoodMass	1,019.20	0.00
tblFireplaces	NumberWood	1.25	0.00
tblFireplaces	NumberWood	48.75	0.00
tblTripsAndVMT	WorkerTripLength	14.70	10.00
tblTripsAndVMT	WorkerTripLength	14.70	10.00
tblTripsAndVMT	WorkerTripLength	14.70	10.00
tblTripsAndVMT	WorkerTripLength	14.70	10.00
tblTripsAndVMT	WorkerTripLength	14.70	10.00
tblTripsAndVMT	WorkerTripLength	14.70	10.00
tblVehicleTrips	ST_TR	7.16	6.17
tblVehicleTrips	ST_TR	6.39	3.87
tblVehicleTrips	ST_TR	2.46	1.39
tblVehicleTrips	ST_TR	158.37	79.82

Village South Specific Plan (Proposed) - Los Angeles-South Coast County, Summer

tblVehicleTrips	ST_TR	8.19	3.75
tblVehicleTrips	ST_TR	94.36	63.99
tblVehicleTrips	ST_TR	49.97	10.74
tblVehicleTrips	SU_TR	6.07	6.16
tblVehicleTrips	SU_TR	5.86	4.18
tblVehicleTrips	SU_TR	1.05	0.69
tblVehicleTrips	SU_TR	131.84	78.27
tblVehicleTrips	SU_TR	5.95	3.20
tblVehicleTrips	SU_TR	72.16	57.65
tblVehicleTrips	SU_TR	25.24	6.39
tblVehicleTrips	WD_TR	6.59	5.83
tblVehicleTrips	WD_TR	6.65	4.13
tblVehicleTrips	WD_TR	11.03	6.41
tblVehicleTrips	WD_TR	127.15	65.80
tblVehicleTrips	WD_TR	8.17	3.84
tblVehicleTrips	WD_TR	89.95	62.64
tblVehicleTrips	WD_TR	42.70	9.43
tblWoodstoves	NumberCatalytic	1.25	0.00
tblWoodstoves	NumberCatalytic	48.75	0.00
tblWoodstoves	NumberNoncatalytic	1.25	0.00
tblWoodstoves	NumberNoncatalytic	48.75	0.00
tblWoodstoves	WoodstoveDayYear	25.00	0.00
tblWoodstoves	WoodstoveDayYear	25.00	0.00
tblWoodstoves	WoodstoveWoodMass	999.60	0.00
tblWoodstoves	WoodstoveWoodMass	999.60	0.00

2.0 Emissions Summary

Village South Specific Plan (Proposed) - Los Angeles-South Coast County, Summer

2.1 Overall Construction (Maximum Daily Emission)

Unmitigated Construction

	ROG	NOx	CO	SO2	Fugitive PM10	Exhaust PM10	PM10 Total	Fugitive PM2.5	Exhaust PM2.5	PM2.5 Total	Bio- CO2	NBio- CO2	Total CO2	CH4	N2O	CO2e
Year	lb/day										lb/day					
2021	4.2561	46.4415	31.4494	0.0636	18.2032	2.0456	20.2488	9.9670	1.8820	11.8490	0.0000	6,163.4166	6,163.4166	1.9475	0.0000	6,212.1039
2022	4.5441	38.8811	40.8776	0.1240	8.8255	1.6361	10.4616	3.6369	1.5052	5.1421	0.0000	12,493.4403	12,493.4403	1.9485	0.0000	12,518.5707
2023	4.1534	25.7658	38.7457	0.1206	7.0088	0.7592	7.7679	1.8799	0.7136	2.5935	0.0000	12,150.4890	12,150.4890	0.9589	0.0000	12,174.4615
2024	237.0219	9.5478	14.9642	0.0239	1.2171	0.4694	1.2875	0.3229	0.4319	0.4621	0.0000	2,313.1808	2,313.1808	0.7166	0.0000	2,331.0956
Maximum	237.0219	46.4415	40.8776	0.1240	18.2032	2.0456	20.2488	9.9670	1.8820	11.8490	0.0000	12,493.4403	12,493.4403	1.9485	0.0000	12,518.5707

Village South Specific Plan (Proposed) - Los Angeles-South Coast County, Summer

2.2 Overall Operational

Unmitigated Operational

	ROG	NOx	CO	SO2	Fugitive PM10	Exhaust PM10	PM10 Total	Fugitive PM2.5	Exhaust PM2.5	PM2.5 Total	Bio- CO2	NBio- CO2	Total CO2	CH4	N2O	CO2e
Category	lb/day										lb/day					
Area	30.5020	15.0496	88.4430	0.0944		1.5974	1.5974		1.5974	1.5974	0.0000	18,148.59 50	18,148.59 50	0.4874	0.3300	18,259.11 92
Energy	0.7660	6.7462	4.2573	0.0418		0.5292	0.5292		0.5292	0.5292		8,355.983 2	8,355.983 2	0.1602	0.1532	8,405.638 7
Mobile	9.8489	45.4304	114.8495	0.4917	45.9592	0.3360	46.2951	12.2950	0.3119	12.6070		50,306.60 34	50,306.60 34	2.1807		50,361.12 08
Total	41.1168	67.2262	207.5497	0.6278	45.9592	2.4626	48.4217	12.2950	2.4385	14.7336	0.0000	76,811.18 16	76,811.18 16	2.8282	0.4832	77,025.87 86

Mitigated Operational

	ROG	NOx	CO	SO2	Fugitive PM10	Exhaust PM10	PM10 Total	Fugitive PM2.5	Exhaust PM2.5	PM2.5 Total	Bio- CO2	NBio- CO2	Total CO2	CH4	N2O	CO2e
Category	lb/day										lb/day					
Area	30.5020	15.0496	88.4430	0.0944		1.5974	1.5974		1.5974	1.5974	0.0000	18,148.59 50	18,148.59 50	0.4874	0.3300	18,259.11 92
Energy	0.7660	6.7462	4.2573	0.0418		0.5292	0.5292		0.5292	0.5292		8,355.983 2	8,355.983 2	0.1602	0.1532	8,405.638 7
Mobile	9.8489	45.4304	114.8495	0.4917	45.9592	0.3360	46.2951	12.2950	0.3119	12.6070		50,306.60 34	50,306.60 34	2.1807		50,361.12 08
Total	41.1168	67.2262	207.5497	0.6278	45.9592	2.4626	48.4217	12.2950	2.4385	14.7336	0.0000	76,811.18 16	76,811.18 16	2.8282	0.4832	77,025.87 86

Village South Specific Plan (Proposed) - Los Angeles-South Coast County, Summer

	ROG	NOx	CO	SO2	Fugitive PM10	Exhaust PM10	PM10 Total	Fugitive PM2.5	Exhaust PM2.5	PM2.5 Total	Bio- CO2	NBio-CO2	Total CO2	CH4	N2O	CO2e
Percent Reduction	0.00	0.00	0.00	0.00	0.00	0.00	0.00	0.00	0.00	0.00	0.00	0.00	0.00	0.00	0.00	0.00

3.0 Construction Detail

Construction Phase

Phase Number	Phase Name	Phase Type	Start Date	End Date	Num Days Week	Num Days	Phase Description
1	Demolition	Demolition	9/1/2021	10/12/2021	5	30	
2	Site Preparation	Site Preparation	10/13/2021	11/9/2021	5	20	
3	Grading	Grading	11/10/2021	1/11/2022	5	45	
4	Building Construction	Building Construction	1/12/2022	12/12/2023	5	500	
5	Paving	Paving	12/13/2023	1/30/2024	5	35	
6	Architectural Coating	Architectural Coating	1/31/2024	3/19/2024	5	35	

Acres of Grading (Site Preparation Phase): 0

Acres of Grading (Grading Phase): 112.5

Acres of Paving: 0

Residential Indoor: 2,025,000; Residential Outdoor: 675,000; Non-Residential Indoor: 326,400; Non-Residential Outdoor: 108,800; Striped Parking Area: 0 (Architectural Coating – sqft)

OffRoad Equipment

Village South Specific Plan (Proposed) - Los Angeles-South Coast County, Summer

Phase Name	Offroad Equipment Type	Amount	Usage Hours	Horse Power	Load Factor
Demolition	Concrete/Industrial Saws	1	8.00	81	0.73
Demolition	Excavators	3	8.00	158	0.38
Demolition	Rubber Tired Dozers	2	8.00	247	0.40
Site Preparation	Rubber Tired Dozers	3	8.00	247	0.40
Site Preparation	Tractors/Loaders/Backhoes	4	8.00	97	0.37
Grading	Excavators	2	8.00	158	0.38
Grading	Graders	1	8.00	187	0.41
Grading	Rubber Tired Dozers	1	8.00	247	0.40
Grading	Scrapers	2	8.00	367	0.48
Grading	Tractors/Loaders/Backhoes	2	8.00	97	0.37
Building Construction	Cranes	1	7.00	231	0.29
Building Construction	Forklifts	3	8.00	89	0.20
Building Construction	Generator Sets	1	8.00	84	0.74
Building Construction	Tractors/Loaders/Backhoes	3	7.00	97	0.37
Building Construction	Welders	1	8.00	46	0.45
Paving	Pavers	2	8.00	130	0.42
Paving	Paving Equipment	2	8.00	132	0.36
Paving	Rollers	2	8.00	80	0.38
Architectural Coating	Air Compressors	1	6.00	78	0.48

Trips and VMT

Village South Specific Plan (Proposed) - Los Angeles-South Coast County, Summer

Phase Name	Offroad Equipment Count	Worker Trip Number	Vendor Trip Number	Hauling Trip Number	Worker Trip Length	Vendor Trip Length	Hauling Trip Length	Worker Vehicle Class	Vendor Vehicle Class	Hauling Vehicle Class
Demolition	6	15.00	0.00	458.00	10.00	6.90	20.00	LD_Mix	HDT_Mix	HHDT
Site Preparation	7	18.00	0.00	0.00	10.00	6.90	20.00	LD_Mix	HDT_Mix	HHDT
Grading	8	20.00	0.00	0.00	10.00	6.90	20.00	LD_Mix	HDT_Mix	HHDT
Building Construction	9	801.00	143.00	0.00	10.00	6.90	20.00	LD_Mix	HDT_Mix	HHDT
Paving	6	15.00	0.00	0.00	10.00	6.90	20.00	LD_Mix	HDT_Mix	HHDT
Architectural Coating	1	160.00	0.00	0.00	10.00	6.90	20.00	LD_Mix	HDT_Mix	HHDT

3.1 Mitigation Measures Construction

3.2 Demolition - 2021

Unmitigated Construction On-Site

	ROG	NOx	CO	SO2	Fugitive PM10	Exhaust PM10	PM10 Total	Fugitive PM2.5	Exhaust PM2.5	PM2.5 Total	Bio- CO2	NBio- CO2	Total CO2	CH4	N2O	CO2e
Category	lb/day										lb/day					
Fugitive Dust					3.3074	0.0000	3.3074	0.5008	0.0000	0.5008			0.0000			0.0000
Off-Road	3.1651	31.4407	21.5650	0.0388		1.5513	1.5513		1.4411	1.4411		3,747.9449	3,747.9449	1.0549		3,774.3174
Total	3.1651	31.4407	21.5650	0.0388	3.3074	1.5513	4.8588	0.5008	1.4411	1.9419		3,747.9449	3,747.9449	1.0549		3,774.3174

Village South Specific Plan (Proposed) - Los Angeles-South Coast County, Summer

3.2 Demolition - 2021

Unmitigated Construction Off-Site

	ROG	NOx	CO	SO2	Fugitive PM10	Exhaust PM10	PM10 Total	Fugitive PM2.5	Exhaust PM2.5	PM2.5 Total	Bio- CO2	NBio- CO2	Total CO2	CH4	N2O	CO2e
Category	lb/day										lb/day					
Hauling	0.1273	4.0952	0.9602	0.0119	0.2669	0.0126	0.2795	0.0732	0.0120	0.0852		1,292.2413	1,292.2413	0.0877		1,294.4337
Vendor	0.0000	0.0000	0.0000	0.0000	0.0000	0.0000	0.0000	0.0000	0.0000	0.0000		0.0000	0.0000	0.0000		0.0000
Worker	0.0487	0.0313	0.4282	1.1800e-003	0.1141	9.5000e-004	0.1151	0.0303	8.8000e-004	0.0311		117.2799	117.2799	3.5200e-003		117.3678
Total	0.1760	4.1265	1.3884	0.0131	0.3810	0.0135	0.3946	0.1034	0.0129	0.1163		1,409.5212	1,409.5212	0.0912		1,411.8015

Mitigated Construction On-Site

	ROG	NOx	CO	SO2	Fugitive PM10	Exhaust PM10	PM10 Total	Fugitive PM2.5	Exhaust PM2.5	PM2.5 Total	Bio- CO2	NBio- CO2	Total CO2	CH4	N2O	CO2e
Category	lb/day										lb/day					
Fugitive Dust					3.3074	0.0000	3.3074	0.5008	0.0000	0.5008			0.0000			0.0000
Off-Road	3.1651	31.4407	21.5650	0.0388		1.5513	1.5513		1.4411	1.4411	0.0000	3,747.9449	3,747.9449	1.0549		3,774.3174
Total	3.1651	31.4407	21.5650	0.0388	3.3074	1.5513	4.8588	0.5008	1.4411	1.9419	0.0000	3,747.9449	3,747.9449	1.0549		3,774.3174

Village South Specific Plan (Proposed) - Los Angeles-South Coast County, Summer

3.2 Demolition - 2021

Mitigated Construction Off-Site

	ROG	NOx	CO	SO2	Fugitive PM10	Exhaust PM10	PM10 Total	Fugitive PM2.5	Exhaust PM2.5	PM2.5 Total	Bio- CO2	NBio- CO2	Total CO2	CH4	N2O	CO2e
Category	lb/day										lb/day					
Hauling	0.1273	4.0952	0.9602	0.0119	0.2669	0.0126	0.2795	0.0732	0.0120	0.0852		1,292.2413	1,292.2413	0.0877		1,294.4337
Vendor	0.0000	0.0000	0.0000	0.0000	0.0000	0.0000	0.0000	0.0000	0.0000	0.0000		0.0000	0.0000	0.0000		0.0000
Worker	0.0487	0.0313	0.4282	1.1800e-003	0.1141	9.5000e-004	0.1151	0.0303	8.8000e-004	0.0311		117.2799	117.2799	3.5200e-003		117.3678
Total	0.1760	4.1265	1.3884	0.0131	0.3810	0.0135	0.3946	0.1034	0.0129	0.1163		1,409.5212	1,409.5212	0.0912		1,411.8015

3.3 Site Preparation - 2021

Unmitigated Construction On-Site

	ROG	NOx	CO	SO2	Fugitive PM10	Exhaust PM10	PM10 Total	Fugitive PM2.5	Exhaust PM2.5	PM2.5 Total	Bio- CO2	NBio- CO2	Total CO2	CH4	N2O	CO2e
Category	lb/day										lb/day					
Fugitive Dust					18.0663	0.0000	18.0663	9.9307	0.0000	9.9307			0.0000			0.0000
Off-Road	3.8882	40.4971	21.1543	0.0380		2.0445	2.0445		1.8809	1.8809		3,685.6569	3,685.6569	1.1920		3,715.4573
Total	3.8882	40.4971	21.1543	0.0380	18.0663	2.0445	20.1107	9.9307	1.8809	11.8116		3,685.6569	3,685.6569	1.1920		3,715.4573

Village South Specific Plan (Proposed) - Los Angeles-South Coast County, Summer

3.3 Site Preparation - 2021

Unmitigated Construction Off-Site

	ROG	NOx	CO	SO2	Fugitive PM10	Exhaust PM10	PM10 Total	Fugitive PM2.5	Exhaust PM2.5	PM2.5 Total	Bio- CO2	NBio- CO2	Total CO2	CH4	N2O	CO2e
Category	lb/day										lb/day					
Hauling	0.0000	0.0000	0.0000	0.0000	0.0000	0.0000	0.0000	0.0000	0.0000	0.0000		0.0000	0.0000	0.0000		0.0000
Vendor	0.0000	0.0000	0.0000	0.0000	0.0000	0.0000	0.0000	0.0000	0.0000	0.0000		0.0000	0.0000	0.0000		0.0000
Worker	0.0584	0.0375	0.5139	1.4100e-003	0.1369	1.1400e-003	0.1381	0.0363	1.0500e-003	0.0374		140.7359	140.7359	4.2200e-003		140.8414
Total	0.0584	0.0375	0.5139	1.4100e-003	0.1369	1.1400e-003	0.1381	0.0363	1.0500e-003	0.0374		140.7359	140.7359	4.2200e-003		140.8414

Mitigated Construction On-Site

	ROG	NOx	CO	SO2	Fugitive PM10	Exhaust PM10	PM10 Total	Fugitive PM2.5	Exhaust PM2.5	PM2.5 Total	Bio- CO2	NBio- CO2	Total CO2	CH4	N2O	CO2e
Category	lb/day										lb/day					
Fugitive Dust					18.0663	0.0000	18.0663	9.9307	0.0000	9.9307			0.0000			0.0000
Off-Road	3.8882	40.4971	21.1543	0.0380		2.0445	2.0445		1.8809	1.8809	0.0000	3,685.6569	3,685.6569	1.1920		3,715.4573
Total	3.8882	40.4971	21.1543	0.0380	18.0663	2.0445	20.1107	9.9307	1.8809	11.8116	0.0000	3,685.6569	3,685.6569	1.1920		3,715.4573

Village South Specific Plan (Proposed) - Los Angeles-South Coast County, Summer

3.3 Site Preparation - 2021

Mitigated Construction Off-Site

	ROG	NOx	CO	SO2	Fugitive PM10	Exhaust PM10	PM10 Total	Fugitive PM2.5	Exhaust PM2.5	PM2.5 Total	Bio- CO2	NBio- CO2	Total CO2	CH4	N2O	CO2e
Category	lb/day										lb/day					
Hauling	0.0000	0.0000	0.0000	0.0000	0.0000	0.0000	0.0000	0.0000	0.0000	0.0000		0.0000	0.0000	0.0000		0.0000
Vendor	0.0000	0.0000	0.0000	0.0000	0.0000	0.0000	0.0000	0.0000	0.0000	0.0000		0.0000	0.0000	0.0000		0.0000
Worker	0.0584	0.0375	0.5139	1.4100e-003	0.1369	1.1400e-003	0.1381	0.0363	1.0500e-003	0.0374		140.7359	140.7359	4.2200e-003		140.8414
Total	0.0584	0.0375	0.5139	1.4100e-003	0.1369	1.1400e-003	0.1381	0.0363	1.0500e-003	0.0374		140.7359	140.7359	4.2200e-003		140.8414

3.4 Grading - 2021

Unmitigated Construction On-Site

	ROG	NOx	CO	SO2	Fugitive PM10	Exhaust PM10	PM10 Total	Fugitive PM2.5	Exhaust PM2.5	PM2.5 Total	Bio- CO2	NBio- CO2	Total CO2	CH4	N2O	CO2e
Category	lb/day										lb/day					
Fugitive Dust					8.6733	0.0000	8.6733	3.5965	0.0000	3.5965			0.0000			0.0000
Off-Road	4.1912	46.3998	30.8785	0.0620		1.9853	1.9853		1.8265	1.8265		6,007.0434	6,007.0434	1.9428		6,055.6134
Total	4.1912	46.3998	30.8785	0.0620	8.6733	1.9853	10.6587	3.5965	1.8265	5.4230		6,007.0434	6,007.0434	1.9428		6,055.6134

Village South Specific Plan (Proposed) - Los Angeles-South Coast County, Summer

3.4 Grading - 2021

Unmitigated Construction Off-Site

	ROG	NOx	CO	SO2	Fugitive PM10	Exhaust PM10	PM10 Total	Fugitive PM2.5	Exhaust PM2.5	PM2.5 Total	Bio- CO2	NBio- CO2	Total CO2	CH4	N2O	CO2e
Category	lb/day										lb/day					
Hauling	0.0000	0.0000	0.0000	0.0000	0.0000	0.0000	0.0000	0.0000	0.0000	0.0000		0.0000	0.0000	0.0000		0.0000
Vendor	0.0000	0.0000	0.0000	0.0000	0.0000	0.0000	0.0000	0.0000	0.0000	0.0000		0.0000	0.0000	0.0000		0.0000
Worker	0.0649	0.0417	0.5710	1.5700e-003	0.1521	1.2700e-003	0.1534	0.0404	1.1700e-003	0.0415		156.3732	156.3732	4.6900e-003		156.4904
Total	0.0649	0.0417	0.5710	1.5700e-003	0.1521	1.2700e-003	0.1534	0.0404	1.1700e-003	0.0415		156.3732	156.3732	4.6900e-003		156.4904

Mitigated Construction On-Site

	ROG	NOx	CO	SO2	Fugitive PM10	Exhaust PM10	PM10 Total	Fugitive PM2.5	Exhaust PM2.5	PM2.5 Total	Bio- CO2	NBio- CO2	Total CO2	CH4	N2O	CO2e
Category	lb/day										lb/day					
Fugitive Dust					8.6733	0.0000	8.6733	3.5965	0.0000	3.5965			0.0000			0.0000
Off-Road	4.1912	46.3998	30.8785	0.0620		1.9853	1.9853		1.8265	1.8265	0.0000	6,007.0434	6,007.0434	1.9428		6,055.6134
Total	4.1912	46.3998	30.8785	0.0620	8.6733	1.9853	10.6587	3.5965	1.8265	5.4230	0.0000	6,007.0434	6,007.0434	1.9428		6,055.6134

Village South Specific Plan (Proposed) - Los Angeles-South Coast County, Summer

3.4 Grading - 2021

Mitigated Construction Off-Site

	ROG	NOx	CO	SO2	Fugitive PM10	Exhaust PM10	PM10 Total	Fugitive PM2.5	Exhaust PM2.5	PM2.5 Total	Bio- CO2	NBio- CO2	Total CO2	CH4	N2O	CO2e
Category	lb/day										lb/day					
Hauling	0.0000	0.0000	0.0000	0.0000	0.0000	0.0000	0.0000	0.0000	0.0000	0.0000		0.0000	0.0000	0.0000		0.0000
Vendor	0.0000	0.0000	0.0000	0.0000	0.0000	0.0000	0.0000	0.0000	0.0000	0.0000		0.0000	0.0000	0.0000		0.0000
Worker	0.0649	0.0417	0.5710	1.5700e-003	0.1521	1.2700e-003	0.1534	0.0404	1.1700e-003	0.0415		156.3732	156.3732	4.6900e-003		156.4904
Total	0.0649	0.0417	0.5710	1.5700e-003	0.1521	1.2700e-003	0.1534	0.0404	1.1700e-003	0.0415		156.3732	156.3732	4.6900e-003		156.4904

3.4 Grading - 2022

Unmitigated Construction On-Site

	ROG	NOx	CO	SO2	Fugitive PM10	Exhaust PM10	PM10 Total	Fugitive PM2.5	Exhaust PM2.5	PM2.5 Total	Bio- CO2	NBio- CO2	Total CO2	CH4	N2O	CO2e
Category	lb/day										lb/day					
Fugitive Dust					8.6733	0.0000	8.6733	3.5965	0.0000	3.5965			0.0000			0.0000
Off-Road	3.6248	38.8435	29.0415	0.0621		1.6349	1.6349		1.5041	1.5041		6,011.4105	6,011.4105	1.9442		6,060.0158
Total	3.6248	38.8435	29.0415	0.0621	8.6733	1.6349	10.3082	3.5965	1.5041	5.1006		6,011.4105	6,011.4105	1.9442		6,060.0158

Village South Specific Plan (Proposed) - Los Angeles-South Coast County, Summer

3.4 Grading - 2022

Unmitigated Construction Off-Site

	ROG	NOx	CO	SO2	Fugitive PM10	Exhaust PM10	PM10 Total	Fugitive PM2.5	Exhaust PM2.5	PM2.5 Total	Bio- CO2	NBio- CO2	Total CO2	CH4	N2O	CO2e
Category	lb/day										lb/day					
Hauling	0.0000	0.0000	0.0000	0.0000	0.0000	0.0000	0.0000	0.0000	0.0000	0.0000		0.0000	0.0000	0.0000		0.0000
Vendor	0.0000	0.0000	0.0000	0.0000	0.0000	0.0000	0.0000	0.0000	0.0000	0.0000		0.0000	0.0000	0.0000		0.0000
Worker	0.0607	0.0376	0.5263	1.5100e-003	0.1521	1.2300e-003	0.1534	0.0404	1.1300e-003	0.0415		150.8754	150.8754	4.2400e-003		150.9813
Total	0.0607	0.0376	0.5263	1.5100e-003	0.1521	1.2300e-003	0.1534	0.0404	1.1300e-003	0.0415		150.8754	150.8754	4.2400e-003		150.9813

Mitigated Construction On-Site

	ROG	NOx	CO	SO2	Fugitive PM10	Exhaust PM10	PM10 Total	Fugitive PM2.5	Exhaust PM2.5	PM2.5 Total	Bio- CO2	NBio- CO2	Total CO2	CH4	N2O	CO2e
Category	lb/day										lb/day					
Fugitive Dust					8.6733	0.0000	8.6733	3.5965	0.0000	3.5965			0.0000			0.0000
Off-Road	3.6248	38.8435	29.0415	0.0621		1.6349	1.6349		1.5041	1.5041	0.0000	6,011.4105	6,011.4105	1.9442		6,060.0158
Total	3.6248	38.8435	29.0415	0.0621	8.6733	1.6349	10.3082	3.5965	1.5041	5.1006	0.0000	6,011.4105	6,011.4105	1.9442		6,060.0158

Village South Specific Plan (Proposed) - Los Angeles-South Coast County, Summer

3.4 Grading - 2022

Mitigated Construction Off-Site

	ROG	NOx	CO	SO2	Fugitive PM10	Exhaust PM10	PM10 Total	Fugitive PM2.5	Exhaust PM2.5	PM2.5 Total	Bio- CO2	NBio- CO2	Total CO2	CH4	N2O	CO2e
Category	lb/day										lb/day					
Hauling	0.0000	0.0000	0.0000	0.0000	0.0000	0.0000	0.0000	0.0000	0.0000	0.0000		0.0000	0.0000	0.0000		0.0000
Vendor	0.0000	0.0000	0.0000	0.0000	0.0000	0.0000	0.0000	0.0000	0.0000	0.0000		0.0000	0.0000	0.0000		0.0000
Worker	0.0607	0.0376	0.5263	1.5100e-003	0.1521	1.2300e-003	0.1534	0.0404	1.1300e-003	0.0415		150.8754	150.8754	4.2400e-003		150.9813
Total	0.0607	0.0376	0.5263	1.5100e-003	0.1521	1.2300e-003	0.1534	0.0404	1.1300e-003	0.0415		150.8754	150.8754	4.2400e-003		150.9813

3.5 Building Construction - 2022

Unmitigated Construction On-Site

	ROG	NOx	CO	SO2	Fugitive PM10	Exhaust PM10	PM10 Total	Fugitive PM2.5	Exhaust PM2.5	PM2.5 Total	Bio- CO2	NBio- CO2	Total CO2	CH4	N2O	CO2e
Category	lb/day										lb/day					
Off-Road	1.7062	15.6156	16.3634	0.0269		0.8090	0.8090		0.7612	0.7612		2,554.3336	2,554.3336	0.6120		2,569.6322
Total	1.7062	15.6156	16.3634	0.0269		0.8090	0.8090		0.7612	0.7612		2,554.3336	2,554.3336	0.6120		2,569.6322

Village South Specific Plan (Proposed) - Los Angeles-South Coast County, Summer

3.5 Building Construction - 2022

Unmitigated Construction Off-Site

	ROG	NOx	CO	SO2	Fugitive PM10	Exhaust PM10	PM10 Total	Fugitive PM2.5	Exhaust PM2.5	PM2.5 Total	Bio- CO2	NBio- CO2	Total CO2	CH4	N2O	CO2e
Category	lb/day										lb/day					
Hauling	0.0000	0.0000	0.0000	0.0000	0.0000	0.0000	0.0000	0.0000	0.0000	0.0000		0.0000	0.0000	0.0000		0.0000
Vendor	0.4079	13.2032	3.4341	0.0364	0.9155	0.0248	0.9404	0.2636	0.0237	0.2873		3,896.548 2	3,896.548 2	0.2236		3,902.138 4
Worker	2.4299	1.5074	21.0801	0.0607	6.0932	0.0493	6.1425	1.6163	0.0454	1.6617		6,042.558 5	6,042.558 5	0.1697		6,046.800 0
Total	2.8378	14.7106	24.5142	0.0971	7.0087	0.0741	7.0828	1.8799	0.0691	1.9490		9,939.106 7	9,939.106 7	0.3933		9,948.938 4

Mitigated Construction On-Site

	ROG	NOx	CO	SO2	Fugitive PM10	Exhaust PM10	PM10 Total	Fugitive PM2.5	Exhaust PM2.5	PM2.5 Total	Bio- CO2	NBio- CO2	Total CO2	CH4	N2O	CO2e
Category	lb/day										lb/day					
Off-Road	1.7062	15.6156	16.3634	0.0269		0.8090	0.8090		0.7612	0.7612	0.0000	2,554.333 6	2,554.333 6	0.6120		2,569.632 2
Total	1.7062	15.6156	16.3634	0.0269		0.8090	0.8090		0.7612	0.7612	0.0000	2,554.333 6	2,554.333 6	0.6120		2,569.632 2

Village South Specific Plan (Proposed) - Los Angeles-South Coast County, Summer

3.5 Building Construction - 2022

Mitigated Construction Off-Site

	ROG	NOx	CO	SO2	Fugitive PM10	Exhaust PM10	PM10 Total	Fugitive PM2.5	Exhaust PM2.5	PM2.5 Total	Bio- CO2	NBio- CO2	Total CO2	CH4	N2O	CO2e
Category	lb/day										lb/day					
Hauling	0.0000	0.0000	0.0000	0.0000	0.0000	0.0000	0.0000	0.0000	0.0000	0.0000		0.0000	0.0000	0.0000		0.0000
Vendor	0.4079	13.2032	3.4341	0.0364	0.9155	0.0248	0.9404	0.2636	0.0237	0.2873		3,896.548 2	3,896.548 2	0.2236		3,902.138 4
Worker	2.4299	1.5074	21.0801	0.0607	6.0932	0.0493	6.1425	1.6163	0.0454	1.6617		6,042.558 5	6,042.558 5	0.1697		6,046.800 0
Total	2.8378	14.7106	24.5142	0.0971	7.0087	0.0741	7.0828	1.8799	0.0691	1.9490		9,939.106 7	9,939.106 7	0.3933		9,948.938 4

3.5 Building Construction - 2023

Unmitigated Construction On-Site

	ROG	NOx	CO	SO2	Fugitive PM10	Exhaust PM10	PM10 Total	Fugitive PM2.5	Exhaust PM2.5	PM2.5 Total	Bio- CO2	NBio- CO2	Total CO2	CH4	N2O	CO2e
Category	lb/day										lb/day					
Off-Road	1.5728	14.3849	16.2440	0.0269		0.6997	0.6997		0.6584	0.6584		2,555.209 9	2,555.209 9	0.6079		2,570.406 1
Total	1.5728	14.3849	16.2440	0.0269		0.6997	0.6997		0.6584	0.6584		2,555.209 9	2,555.209 9	0.6079		2,570.406 1

Village South Specific Plan (Proposed) - Los Angeles-South Coast County, Summer

3.5 Building Construction - 2023

Unmitigated Construction Off-Site

	ROG	NOx	CO	SO2	Fugitive PM10	Exhaust PM10	PM10 Total	Fugitive PM2.5	Exhaust PM2.5	PM2.5 Total	Bio- CO2	NBio- CO2	Total CO2	CH4	N2O	CO2e
Category	lb/day										lb/day					
Hauling	0.0000	0.0000	0.0000	0.0000	0.0000	0.0000	0.0000	0.0000	0.0000	0.0000		0.0000	0.0000	0.0000		0.0000
Vendor	0.3027	10.0181	3.1014	0.0352	0.9156	0.0116	0.9271	0.2636	0.0111	0.2747		3,773.876 2	3,773.876 2	0.1982		3,778.830 0
Worker	2.2780	1.3628	19.4002	0.0584	6.0932	0.0479	6.1411	1.6163	0.0441	1.6604		5,821.402 8	5,821.402 8	0.1529		5,825.225 4
Total	2.5807	11.3809	22.5017	0.0936	7.0088	0.0595	7.0682	1.8799	0.0552	1.9350		9,595.279 0	9,595.279 0	0.3511		9,604.055 4

Mitigated Construction On-Site

	ROG	NOx	CO	SO2	Fugitive PM10	Exhaust PM10	PM10 Total	Fugitive PM2.5	Exhaust PM2.5	PM2.5 Total	Bio- CO2	NBio- CO2	Total CO2	CH4	N2O	CO2e
Category	lb/day										lb/day					
Off-Road	1.5728	14.3849	16.2440	0.0269		0.6997	0.6997		0.6584	0.6584	0.0000	2,555.209 9	2,555.209 9	0.6079		2,570.406 1
Total	1.5728	14.3849	16.2440	0.0269		0.6997	0.6997		0.6584	0.6584	0.0000	2,555.209 9	2,555.209 9	0.6079		2,570.406 1

Village South Specific Plan (Proposed) - Los Angeles-South Coast County, Summer

3.5 Building Construction - 2023

Mitigated Construction Off-Site

	ROG	NOx	CO	SO2	Fugitive PM10	Exhaust PM10	PM10 Total	Fugitive PM2.5	Exhaust PM2.5	PM2.5 Total	Bio- CO2	NBio- CO2	Total CO2	CH4	N2O	CO2e
Category	lb/day										lb/day					
Hauling	0.0000	0.0000	0.0000	0.0000	0.0000	0.0000	0.0000	0.0000	0.0000	0.0000		0.0000	0.0000	0.0000		0.0000
Vendor	0.3027	10.0181	3.1014	0.0352	0.9156	0.0116	0.9271	0.2636	0.0111	0.2747		3,773.876 2	3,773.876 2	0.1982		3,778.830 0
Worker	2.2780	1.3628	19.4002	0.0584	6.0932	0.0479	6.1411	1.6163	0.0441	1.6604		5,821.402 8	5,821.402 8	0.1529		5,825.225 4
Total	2.5807	11.3809	22.5017	0.0936	7.0088	0.0595	7.0682	1.8799	0.0552	1.9350		9,595.279 0	9,595.279 0	0.3511		9,604.055 4

3.6 Paving - 2023

Unmitigated Construction On-Site

	ROG	NOx	CO	SO2	Fugitive PM10	Exhaust PM10	PM10 Total	Fugitive PM2.5	Exhaust PM2.5	PM2.5 Total	Bio- CO2	NBio- CO2	Total CO2	CH4	N2O	CO2e
Category	lb/day										lb/day					
Off-Road	1.0327	10.1917	14.5842	0.0228		0.5102	0.5102		0.4694	0.4694		2,207.584 1	2,207.584 1	0.7140		2,225.433 6
Paving	0.0000					0.0000	0.0000		0.0000	0.0000			0.0000			0.0000
Total	1.0327	10.1917	14.5842	0.0228		0.5102	0.5102		0.4694	0.4694		2,207.584 1	2,207.584 1	0.7140		2,225.433 6

Village South Specific Plan (Proposed) - Los Angeles-South Coast County, Summer

3.6 Paving - 2023

Unmitigated Construction Off-Site

	ROG	NOx	CO	SO2	Fugitive PM10	Exhaust PM10	PM10 Total	Fugitive PM2.5	Exhaust PM2.5	PM2.5 Total	Bio- CO2	NBio- CO2	Total CO2	CH4	N2O	CO2e
Category	lb/day										lb/day					
Hauling	0.0000	0.0000	0.0000	0.0000	0.0000	0.0000	0.0000	0.0000	0.0000	0.0000		0.0000	0.0000	0.0000		0.0000
Vendor	0.0000	0.0000	0.0000	0.0000	0.0000	0.0000	0.0000	0.0000	0.0000	0.0000		0.0000	0.0000	0.0000		0.0000
Worker	0.0427	0.0255	0.3633	1.0900e-003	0.1141	9.0000e-004	0.1150	0.0303	8.3000e-004	0.0311		109.0150	109.0150	2.8600e-003		109.0866
Total	0.0427	0.0255	0.3633	1.0900e-003	0.1141	9.0000e-004	0.1150	0.0303	8.3000e-004	0.0311		109.0150	109.0150	2.8600e-003		109.0866

Mitigated Construction On-Site

	ROG	NOx	CO	SO2	Fugitive PM10	Exhaust PM10	PM10 Total	Fugitive PM2.5	Exhaust PM2.5	PM2.5 Total	Bio- CO2	NBio- CO2	Total CO2	CH4	N2O	CO2e
Category	lb/day										lb/day					
Off-Road	1.0327	10.1917	14.5842	0.0228		0.5102	0.5102		0.4694	0.4694	0.0000	2,207.5841	2,207.5841	0.7140		2,225.4336
Paving	0.0000					0.0000	0.0000		0.0000	0.0000			0.0000			0.0000
Total	1.0327	10.1917	14.5842	0.0228		0.5102	0.5102		0.4694	0.4694	0.0000	2,207.5841	2,207.5841	0.7140		2,225.4336

Village South Specific Plan (Proposed) - Los Angeles-South Coast County, Summer

3.6 Paving - 2023

Mitigated Construction Off-Site

	ROG	NOx	CO	SO2	Fugitive PM10	Exhaust PM10	PM10 Total	Fugitive PM2.5	Exhaust PM2.5	PM2.5 Total	Bio- CO2	NBio- CO2	Total CO2	CH4	N2O	CO2e
Category	lb/day										lb/day					
Hauling	0.0000	0.0000	0.0000	0.0000	0.0000	0.0000	0.0000	0.0000	0.0000	0.0000		0.0000	0.0000	0.0000		0.0000
Vendor	0.0000	0.0000	0.0000	0.0000	0.0000	0.0000	0.0000	0.0000	0.0000	0.0000		0.0000	0.0000	0.0000		0.0000
Worker	0.0427	0.0255	0.3633	1.0900e-003	0.1141	9.0000e-004	0.1150	0.0303	8.3000e-004	0.0311		109.0150	109.0150	2.8600e-003		109.0866
Total	0.0427	0.0255	0.3633	1.0900e-003	0.1141	9.0000e-004	0.1150	0.0303	8.3000e-004	0.0311		109.0150	109.0150	2.8600e-003		109.0866

3.6 Paving - 2024

Unmitigated Construction On-Site

	ROG	NOx	CO	SO2	Fugitive PM10	Exhaust PM10	PM10 Total	Fugitive PM2.5	Exhaust PM2.5	PM2.5 Total	Bio- CO2	NBio- CO2	Total CO2	CH4	N2O	CO2e
Category	lb/day										lb/day					
Off-Road	0.9882	9.5246	14.6258	0.0228		0.4685	0.4685		0.4310	0.4310		2,207.5472	2,207.5472	0.7140		2,225.3963
Paving	0.0000					0.0000	0.0000		0.0000	0.0000			0.0000			0.0000
Total	0.9882	9.5246	14.6258	0.0228		0.4685	0.4685		0.4310	0.4310		2,207.5472	2,207.5472	0.7140		2,225.3963

Village South Specific Plan (Proposed) - Los Angeles-South Coast County, Summer

3.6 Paving - 2024

Unmitigated Construction Off-Site

	ROG	NOx	CO	SO2	Fugitive PM10	Exhaust PM10	PM10 Total	Fugitive PM2.5	Exhaust PM2.5	PM2.5 Total	Bio- CO2	NBio- CO2	Total CO2	CH4	N2O	CO2e
Category	lb/day										lb/day					
Hauling	0.0000	0.0000	0.0000	0.0000	0.0000	0.0000	0.0000	0.0000	0.0000	0.0000		0.0000	0.0000	0.0000		0.0000
Vendor	0.0000	0.0000	0.0000	0.0000	0.0000	0.0000	0.0000	0.0000	0.0000	0.0000		0.0000	0.0000	0.0000		0.0000
Worker	0.0403	0.0233	0.3384	1.0600e-003	0.1141	8.8000e-004	0.1150	0.0303	8.1000e-004	0.0311		105.6336	105.6336	2.6300e-003		105.6992
Total	0.0403	0.0233	0.3384	1.0600e-003	0.1141	8.8000e-004	0.1150	0.0303	8.1000e-004	0.0311		105.6336	105.6336	2.6300e-003		105.6992

Mitigated Construction On-Site

	ROG	NOx	CO	SO2	Fugitive PM10	Exhaust PM10	PM10 Total	Fugitive PM2.5	Exhaust PM2.5	PM2.5 Total	Bio- CO2	NBio- CO2	Total CO2	CH4	N2O	CO2e
Category	lb/day										lb/day					
Off-Road	0.9882	9.5246	14.6258	0.0228		0.4685	0.4685		0.4310	0.4310	0.0000	2,207.5472	2,207.5472	0.7140		2,225.3963
Paving	0.0000					0.0000	0.0000		0.0000	0.0000			0.0000			0.0000
Total	0.9882	9.5246	14.6258	0.0228		0.4685	0.4685		0.4310	0.4310	0.0000	2,207.5472	2,207.5472	0.7140		2,225.3963

Village South Specific Plan (Proposed) - Los Angeles-South Coast County, Summer

3.6 Paving - 2024

Mitigated Construction Off-Site

	ROG	NOx	CO	SO2	Fugitive PM10	Exhaust PM10	PM10 Total	Fugitive PM2.5	Exhaust PM2.5	PM2.5 Total	Bio- CO2	NBio- CO2	Total CO2	CH4	N2O	CO2e
Category	lb/day										lb/day					
Hauling	0.0000	0.0000	0.0000	0.0000	0.0000	0.0000	0.0000	0.0000	0.0000	0.0000		0.0000	0.0000	0.0000		0.0000
Vendor	0.0000	0.0000	0.0000	0.0000	0.0000	0.0000	0.0000	0.0000	0.0000	0.0000		0.0000	0.0000	0.0000		0.0000
Worker	0.0403	0.0233	0.3384	1.0600e-003	0.1141	8.8000e-004	0.1150	0.0303	8.1000e-004	0.0311		105.6336	105.6336	2.6300e-003		105.6992
Total	0.0403	0.0233	0.3384	1.0600e-003	0.1141	8.8000e-004	0.1150	0.0303	8.1000e-004	0.0311		105.6336	105.6336	2.6300e-003		105.6992

3.7 Architectural Coating - 2024

Unmitigated Construction On-Site

	ROG	NOx	CO	SO2	Fugitive PM10	Exhaust PM10	PM10 Total	Fugitive PM2.5	Exhaust PM2.5	PM2.5 Total	Bio- CO2	NBio- CO2	Total CO2	CH4	N2O	CO2e
Category	lb/day										lb/day					
Archit. Coating	236.4115					0.0000	0.0000		0.0000	0.0000			0.0000			0.0000
Off-Road	0.1808	1.2188	1.8101	2.9700e-003		0.0609	0.0609		0.0609	0.0609		281.4481	281.4481	0.0159		281.8443
Total	236.5923	1.2188	1.8101	2.9700e-003		0.0609	0.0609		0.0609	0.0609		281.4481	281.4481	0.0159		281.8443

Village South Specific Plan (Proposed) - Los Angeles-South Coast County, Summer

3.7 Architectural Coating - 2024

Unmitigated Construction Off-Site

	ROG	NOx	CO	SO2	Fugitive PM10	Exhaust PM10	PM10 Total	Fugitive PM2.5	Exhaust PM2.5	PM2.5 Total	Bio- CO2	NBio- CO2	Total CO2	CH4	N2O	CO2e
Category	lb/day										lb/day					
Hauling	0.0000	0.0000	0.0000	0.0000	0.0000	0.0000	0.0000	0.0000	0.0000	0.0000		0.0000	0.0000	0.0000		0.0000
Vendor	0.0000	0.0000	0.0000	0.0000	0.0000	0.0000	0.0000	0.0000	0.0000	0.0000		0.0000	0.0000	0.0000		0.0000
Worker	0.4296	0.2481	3.6098	0.0113	1.2171	9.4300e-003	1.2266	0.3229	8.6800e-003	0.3315		1,126.7583	1,126.7583	0.0280		1,127.4583
Total	0.4296	0.2481	3.6098	0.0113	1.2171	9.4300e-003	1.2266	0.3229	8.6800e-003	0.3315		1,126.7583	1,126.7583	0.0280		1,127.4583

Mitigated Construction On-Site

	ROG	NOx	CO	SO2	Fugitive PM10	Exhaust PM10	PM10 Total	Fugitive PM2.5	Exhaust PM2.5	PM2.5 Total	Bio- CO2	NBio- CO2	Total CO2	CH4	N2O	CO2e
Category	lb/day										lb/day					
Archit. Coating	236.4115					0.0000	0.0000		0.0000	0.0000			0.0000			0.0000
Off-Road	0.1808	1.2188	1.8101	2.9700e-003		0.0609	0.0609		0.0609	0.0609	0.0000	281.4481	281.4481	0.0159		281.8443
Total	236.5923	1.2188	1.8101	2.9700e-003		0.0609	0.0609		0.0609	0.0609	0.0000	281.4481	281.4481	0.0159		281.8443

Village South Specific Plan (Proposed) - Los Angeles-South Coast County, Summer

3.7 Architectural Coating - 2024

Mitigated Construction Off-Site

	ROG	NOx	CO	SO2	Fugitive PM10	Exhaust PM10	PM10 Total	Fugitive PM2.5	Exhaust PM2.5	PM2.5 Total	Bio- CO2	NBio- CO2	Total CO2	CH4	N2O	CO2e
Category	lb/day										lb/day					
Hauling	0.0000	0.0000	0.0000	0.0000	0.0000	0.0000	0.0000	0.0000	0.0000	0.0000		0.0000	0.0000	0.0000		0.0000
Vendor	0.0000	0.0000	0.0000	0.0000	0.0000	0.0000	0.0000	0.0000	0.0000	0.0000		0.0000	0.0000	0.0000		0.0000
Worker	0.4296	0.2481	3.6098	0.0113	1.2171	9.4300e-003	1.2266	0.3229	8.6800e-003	0.3315		1,126.7583	1,126.7583	0.0280		1,127.4583
Total	0.4296	0.2481	3.6098	0.0113	1.2171	9.4300e-003	1.2266	0.3229	8.6800e-003	0.3315		1,126.7583	1,126.7583	0.0280		1,127.4583

4.0 Operational Detail - Mobile

4.1 Mitigation Measures Mobile

Village South Specific Plan (Proposed) - Los Angeles-South Coast County, Summer

	ROG	NOx	CO	SO2	Fugitive PM10	Exhaust PM10	PM10 Total	Fugitive PM2.5	Exhaust PM2.5	PM2.5 Total	Bio- CO2	NBio- CO2	Total CO2	CH4	N2O	CO2e
Category	lb/day										lb/day					
Mitigated	9.8489	45.4304	114.8495	0.4917	45.9592	0.3360	46.2951	12.2950	0.3119	12.6070		50,306.60 34	50,306.60 34	2.1807		50,361.12 08
Unmitigated	9.8489	45.4304	114.8495	0.4917	45.9592	0.3360	46.2951	12.2950	0.3119	12.6070		50,306.60 34	50,306.60 34	2.1807		50,361.12 08

4.2 Trip Summary Information

Land Use	Average Daily Trip Rate			Unmitigated	Mitigated
	Weekday	Saturday	Sunday	Annual VMT	Annual VMT
Apartments Low Rise	145.75	154.25	154.00	506,227	506,227
Apartments Mid Rise	4,026.75	3,773.25	4075.50	13,660,065	13,660,065
General Office Building	288.45	62.55	31.05	706,812	706,812
High Turnover (Sit Down Restaurant)	2,368.80	2,873.52	2817.72	3,413,937	3,413,937
Hotel	192.00	187.50	160.00	445,703	445,703
Quality Restaurant	501.12	511.92	461.20	707,488	707,488
Regional Shopping Center	528.08	601.44	357.84	1,112,221	1,112,221
Total	8,050.95	8,164.43	8,057.31	20,552,452	20,552,452

4.3 Trip Type Information

Village South Specific Plan (Proposed) - Los Angeles-South Coast County, Summer

Land Use	Miles			Trip %			Trip Purpose %		
	H-W or C-W	H-S or C-C	H-O or C-NW	H-W or C-W	H-S or C-C	H-O or C-NW	Primary	Diverted	Pass-by
Apartments Low Rise	14.70	5.90	8.70	40.20	19.20	40.60	86	11	3
Apartments Mid Rise	14.70	5.90	8.70	40.20	19.20	40.60	86	11	3
General Office Building	16.60	8.40	6.90	33.00	48.00	19.00	77	19	4
High Turnover (Sit Down Restaurant)	16.60	8.40	6.90	8.50	72.50	19.00	37	20	43
Hotel	16.60	8.40	6.90	19.40	61.60	19.00	58	38	4
Quality Restaurant	16.60	8.40	6.90	12.00	69.00	19.00	38	18	44
Regional Shopping Center	16.60	8.40	6.90	16.30	64.70	19.00	54	35	11

4.4 Fleet Mix

Land Use	LDA	LDT1	LDT2	MDV	LHD1	LHD2	MHD	HHD	OBUS	UBUS	MCY	SBUS	MH
Apartments Low Rise	0.543088	0.044216	0.209971	0.116369	0.014033	0.006332	0.021166	0.033577	0.002613	0.001817	0.005285	0.000712	0.000821
Apartments Mid Rise	0.543088	0.044216	0.209971	0.116369	0.014033	0.006332	0.021166	0.033577	0.002613	0.001817	0.005285	0.000712	0.000821
General Office Building	0.543088	0.044216	0.209971	0.116369	0.014033	0.006332	0.021166	0.033577	0.002613	0.001817	0.005285	0.000712	0.000821
High Turnover (Sit Down Restaurant)	0.543088	0.044216	0.209971	0.116369	0.014033	0.006332	0.021166	0.033577	0.002613	0.001817	0.005285	0.000712	0.000821
Hotel	0.543088	0.044216	0.209971	0.116369	0.014033	0.006332	0.021166	0.033577	0.002613	0.001817	0.005285	0.000712	0.000821
Quality Restaurant	0.543088	0.044216	0.209971	0.116369	0.014033	0.006332	0.021166	0.033577	0.002613	0.001817	0.005285	0.000712	0.000821
Regional Shopping Center	0.543088	0.044216	0.209971	0.116369	0.014033	0.006332	0.021166	0.033577	0.002613	0.001817	0.005285	0.000712	0.000821

5.0 Energy Detail

Historical Energy Use: N

5.1 Mitigation Measures Energy

Village South Specific Plan (Proposed) - Los Angeles-South Coast County, Summer

	ROG	NOx	CO	SO2	Fugitive PM10	Exhaust PM10	PM10 Total	Fugitive PM2.5	Exhaust PM2.5	PM2.5 Total	Bio- CO2	NBio- CO2	Total CO2	CH4	N2O	CO2e
Category	lb/day										lb/day					
NaturalGas Mitigated	0.7660	6.7462	4.2573	0.0418		0.5292	0.5292		0.5292	0.5292		8,355.983 2	8,355.983 2	0.1602	0.1532	8,405.638 7
NaturalGas Unmitigated	0.7660	6.7462	4.2573	0.0418		0.5292	0.5292		0.5292	0.5292		8,355.983 2	8,355.983 2	0.1602	0.1532	8,405.638 7

Village South Specific Plan (Proposed) - Los Angeles-South Coast County, Summer

5.2 Energy by Land Use - NaturalGas

Unmitigated

	NaturalGas Use	ROG	NOx	CO	SO2	Fugitive PM10	Exhaust PM10	PM10 Total	Fugitive PM2.5	Exhaust PM2.5	PM2.5 Total	Bio- CO2	NBio- CO2	Total CO2	CH4	N2O	CO2e
Land Use	kBTU/yr	lb/day										lb/day					
Apartments Low Rise	1119.16	0.0121	0.1031	0.0439	6.6000e-004		8.3400e-003	8.3400e-003		8.3400e-003	8.3400e-003		131.6662	131.6662	2.5200e-003	2.4100e-003	132.4486
Apartments Mid Rise	35784.3	0.3859	3.2978	1.4033	0.0211		0.2666	0.2666		0.2666	0.2666		4,209.9164	4,209.9164	0.0807	0.0772	4,234.9339
General Office Building	1283.42	0.0138	0.1258	0.1057	7.5000e-004		9.5600e-003	9.5600e-003		9.5600e-003	9.5600e-003		150.9911	150.9911	2.8900e-003	2.7700e-003	151.8884
High Turnover (Sit Down Restaurant)	22759.9	0.2455	2.2314	1.8743	0.0134		0.1696	0.1696		0.1696	0.1696		2,677.6342	2,677.6342	0.0513	0.0491	2,693.5460
Hotel	4769.72	0.0514	0.4676	0.3928	2.8100e-003		0.0355	0.0355		0.0355	0.0355		561.1436	561.1436	0.0108	0.0103	564.4782
Quality Restaurant	5057.75	0.0545	0.4959	0.4165	2.9800e-003		0.0377	0.0377		0.0377	0.0377		595.0298	595.0298	0.0114	0.0109	598.5658
Regional Shopping Center	251.616	2.7100e-003	0.0247	0.0207	1.5000e-004		1.8700e-003	1.8700e-003		1.8700e-003	1.8700e-003		29.6019	29.6019	5.7000e-004	5.4000e-004	29.7778
Total		0.7660	6.7463	4.2573	0.0418		0.5292	0.5292		0.5292	0.5292		8,355.9832	8,355.9832	0.1602	0.1532	8,405.6387

Village South Specific Plan (Proposed) - Los Angeles-South Coast County, Summer

5.2 Energy by Land Use - NaturalGas

Mitigated

	NaturalGas Use	ROG	NOx	CO	SO2	Fugitive PM10	Exhaust PM10	PM10 Total	Fugitive PM2.5	Exhaust PM2.5	PM2.5 Total	Bio- CO2	NBio- CO2	Total CO2	CH4	N2O	CO2e
Land Use	kBTU/yr	lb/day										lb/day					
Apartments Low Rise	1.11916	0.0121	0.1031	0.0439	6.6000e-004		8.3400e-003	8.3400e-003		8.3400e-003	8.3400e-003		131.6662	131.6662	2.5200e-003	2.4100e-003	132.4486
Apartments Mid Rise	35.7843	0.3859	3.2978	1.4033	0.0211		0.2666	0.2666		0.2666	0.2666		4,209.9164	4,209.9164	0.0807	0.0772	4,234.9339
General Office Building	1.28342	0.0138	0.1258	0.1057	7.5000e-004		9.5600e-003	9.5600e-003		9.5600e-003	9.5600e-003		150.9911	150.9911	2.8900e-003	2.7700e-003	151.8884
High Turnover (Sit Down Restaurant)	22.7599	0.2455	2.2314	1.8743	0.0134		0.1696	0.1696		0.1696	0.1696		2,677.6342	2,677.6342	0.0513	0.0491	2,693.5460
Hotel	4.76972	0.0514	0.4676	0.3928	2.8100e-003		0.0355	0.0355		0.0355	0.0355		561.1436	561.1436	0.0108	0.0103	564.4782
Quality Restaurant	5.05775	0.0545	0.4959	0.4165	2.9800e-003		0.0377	0.0377		0.0377	0.0377		595.0298	595.0298	0.0114	0.0109	598.5658
Regional Shopping Center	0.251616	2.7100e-003	0.0247	0.0207	1.5000e-004		1.8700e-003	1.8700e-003		1.8700e-003	1.8700e-003		29.6019	29.6019	5.7000e-004	5.4000e-004	29.7778
Total		0.7660	6.7463	4.2573	0.0418		0.5292	0.5292		0.5292	0.5292		8,355.9832	8,355.9832	0.1602	0.1532	8,405.6387

6.0 Area Detail

6.1 Mitigation Measures Area

Village South Specific Plan (Proposed) - Los Angeles-South Coast County, Summer

	ROG	NOx	CO	SO2	Fugitive PM10	Exhaust PM10	PM10 Total	Fugitive PM2.5	Exhaust PM2.5	PM2.5 Total	Bio- CO2	NBio- CO2	Total CO2	CH4	N2O	CO2e
Category	lb/day										lb/day					
Mitigated	30.5020	15.0496	88.4430	0.0944		1.5974	1.5974		1.5974	1.5974	0.0000	18,148.5950	18,148.5950	0.4874	0.3300	18,259.1192
Unmitigated	30.5020	15.0496	88.4430	0.0944		1.5974	1.5974		1.5974	1.5974	0.0000	18,148.5950	18,148.5950	0.4874	0.3300	18,259.1192

6.2 Area by SubCategory

Unmitigated

	ROG	NOx	CO	SO2	Fugitive PM10	Exhaust PM10	PM10 Total	Fugitive PM2.5	Exhaust PM2.5	PM2.5 Total	Bio- CO2	NBio- CO2	Total CO2	CH4	N2O	CO2e
SubCategory	lb/day										lb/day					
Architectural Coating	2.2670					0.0000	0.0000		0.0000	0.0000			0.0000			0.0000
Consumer Products	24.1085					0.0000	0.0000		0.0000	0.0000			0.0000			0.0000
Hearth	1.6500	14.1000	6.0000	0.0900		1.1400	1.1400		1.1400	1.1400	0.0000	18,000.0000	18,000.0000	0.3450	0.3300	18,106.9650
Landscaping	2.4766	0.9496	82.4430	4.3600e-003		0.4574	0.4574		0.4574	0.4574		148.5950	148.5950	0.1424		152.1542
Total	30.5020	15.0496	88.4430	0.0944		1.5974	1.5974		1.5974	1.5974	0.0000	18,148.5950	18,148.5950	0.4874	0.3300	18,259.1192

Village South Specific Plan (Proposed) - Los Angeles-South Coast County, Summer

6.2 Area by SubCategory

Mitigated

	ROG	NOx	CO	SO2	Fugitive PM10	Exhaust PM10	PM10 Total	Fugitive PM2.5	Exhaust PM2.5	PM2.5 Total	Bio- CO2	NBio- CO2	Total CO2	CH4	N2O	CO2e
SubCategory	lb/day										lb/day					
Architectural Coating	2.2670					0.0000	0.0000		0.0000	0.0000			0.0000			0.0000
Consumer Products	24.1085					0.0000	0.0000		0.0000	0.0000			0.0000			0.0000
Hearth	1.6500	14.1000	6.0000	0.0900		1.1400	1.1400		1.1400	1.1400	0.0000	18,000.0000	18,000.0000	0.3450	0.3300	18,106.9650
Landscaping	2.4766	0.9496	82.4430	4.3600e-003		0.4574	0.4574		0.4574	0.4574		148.5950	148.5950	0.1424		152.1542
Total	30.5020	15.0496	88.4430	0.0944		1.5974	1.5974		1.5974	1.5974	0.0000	18,148.5950	18,148.5950	0.4874	0.3300	18,259.1192

7.0 Water Detail

7.1 Mitigation Measures Water

8.0 Waste Detail

8.1 Mitigation Measures Waste

9.0 Operational Offroad

Equipment Type	Number	Hours/Day	Days/Year	Horse Power	Load Factor	Fuel Type
----------------	--------	-----------	-----------	-------------	-------------	-----------

10.0 Stationary Equipment

Village South Specific Plan (Proposed) - Los Angeles-South Coast County, Summer

Fire Pumps and Emergency Generators

Equipment Type	Number	Hours/Day	Hours/Year	Horse Power	Load Factor	Fuel Type
----------------	--------	-----------	------------	-------------	-------------	-----------

Boilers

Equipment Type	Number	Heat Input/Day	Heat Input/Year	Boiler Rating	Fuel Type
----------------	--------	----------------	-----------------	---------------	-----------

User Defined Equipment

Equipment Type	Number
----------------	--------

11.0 Vegetation

Village South Specific Plan (Proposed) - Los Angeles-South Coast County, Winter

Village South Specific Plan (Proposed)
Los Angeles-South Coast County, Winter

1.0 Project Characteristics

1.1 Land Usage

Land Uses	Size	Metric	Lot Acreage	Floor Surface Area	Population
General Office Building	45.00	1000sqft	1.03	45,000.00	0
High Turnover (Sit Down Restaurant)	36.00	1000sqft	0.83	36,000.00	0
Hotel	50.00	Room	1.67	72,600.00	0
Quality Restaurant	8.00	1000sqft	0.18	8,000.00	0
Apartments Low Rise	25.00	Dwelling Unit	1.56	25,000.00	72
Apartments Mid Rise	975.00	Dwelling Unit	25.66	975,000.00	2789
Regional Shopping Center	56.00	1000sqft	1.29	56,000.00	0

1.2 Other Project Characteristics

Urbanization	Urban	Wind Speed (m/s)	2.2	Precipitation Freq (Days)	33
Climate Zone	9			Operational Year	2028
Utility Company	Southern California Edison				
CO2 Intensity (lb/MW hr)	702.44	CH4 Intensity (lb/MW hr)	0.029	N2O Intensity (lb/MW hr)	0.006

1.3 User Entered Comments & Non-Default Data

Village South Specific Plan (Proposed) - Los Angeles-South Coast County, Winter

Project Characteristics - Consistent with the DEIR's model.

Land Use - See SWAPE comment regarding residential and retail land uses.

Construction Phase - See SWAPE comment regarding individual construction phase lengths.

Demolition - Consistent with the DEIR's model. See SWAPE comment regarding demolition.

Vehicle Trips - Saturday trips consistent with the DEIR's model. See SWAPE comment regarding weekday and Sunday trips.

Woodstoves - Woodstoves and wood-burning fireplaces consistent with the DEIR's model. See SWAPE comment regarding gas fireplaces.

Energy Use -

Construction Off-road Equipment Mitigation - See SWAPE comment on construction-related mitigation.

Area Mitigation - See SWAPE comment regarding operational mitigation measures.

Water Mitigation - See SWAPE comment regarding operational mitigation measures.

Trips and VMT - Local hire provision

Table Name	Column Name	Default Value	New Value
tblFireplaces	FireplaceWoodMass	1,019.20	0.00
tblFireplaces	FireplaceWoodMass	1,019.20	0.00
tblFireplaces	NumberWood	1.25	0.00
tblFireplaces	NumberWood	48.75	0.00
tblTripsAndVMT	WorkerTripLength	14.70	10.00
tblTripsAndVMT	WorkerTripLength	14.70	10.00
tblTripsAndVMT	WorkerTripLength	14.70	10.00
tblTripsAndVMT	WorkerTripLength	14.70	10.00
tblTripsAndVMT	WorkerTripLength	14.70	10.00
tblTripsAndVMT	WorkerTripLength	14.70	10.00
tblVehicleTrips	ST_TR	7.16	6.17
tblVehicleTrips	ST_TR	6.39	3.87
tblVehicleTrips	ST_TR	2.46	1.39
tblVehicleTrips	ST_TR	158.37	79.82

Village South Specific Plan (Proposed) - Los Angeles-South Coast County, Winter

tblVehicleTrips	ST_TR	8.19	3.75
tblVehicleTrips	ST_TR	94.36	63.99
tblVehicleTrips	ST_TR	49.97	10.74
tblVehicleTrips	SU_TR	6.07	6.16
tblVehicleTrips	SU_TR	5.86	4.18
tblVehicleTrips	SU_TR	1.05	0.69
tblVehicleTrips	SU_TR	131.84	78.27
tblVehicleTrips	SU_TR	5.95	3.20
tblVehicleTrips	SU_TR	72.16	57.65
tblVehicleTrips	SU_TR	25.24	6.39
tblVehicleTrips	WD_TR	6.59	5.83
tblVehicleTrips	WD_TR	6.65	4.13
tblVehicleTrips	WD_TR	11.03	6.41
tblVehicleTrips	WD_TR	127.15	65.80
tblVehicleTrips	WD_TR	8.17	3.84
tblVehicleTrips	WD_TR	89.95	62.64
tblVehicleTrips	WD_TR	42.70	9.43
tblWoodstoves	NumberCatalytic	1.25	0.00
tblWoodstoves	NumberCatalytic	48.75	0.00
tblWoodstoves	NumberNoncatalytic	1.25	0.00
tblWoodstoves	NumberNoncatalytic	48.75	0.00
tblWoodstoves	WoodstoveDayYear	25.00	0.00
tblWoodstoves	WoodstoveDayYear	25.00	0.00
tblWoodstoves	WoodstoveWoodMass	999.60	0.00
tblWoodstoves	WoodstoveWoodMass	999.60	0.00

2.0 Emissions Summary

Village South Specific Plan (Proposed) - Los Angeles-South Coast County, Winter

2.1 Overall Construction (Maximum Daily Emission)

Unmitigated Construction

	ROG	NOx	CO	SO2	Fugitive PM10	Exhaust PM10	PM10 Total	Fugitive PM2.5	Exhaust PM2.5	PM2.5 Total	Bio- CO2	NBio- CO2	Total CO2	CH4	N2O	CO2e
Year	lb/day										lb/day					
2021	4.2621	46.4460	31.4068	0.0635	18.2032	2.0456	20.2488	9.9670	1.8820	11.8490	0.0000	6,154.3377	6,154.3377	1.9472	0.0000	6,203.0186
2022	4.7966	38.8851	39.6338	0.1195	8.8255	1.6361	10.4616	3.6369	1.5052	5.1421	0.0000	12,035.3440	12,035.3440	1.9482	0.0000	12,060.6013
2023	4.3939	25.8648	37.5031	0.1162	7.0088	0.7598	7.7685	1.8799	0.7142	2.5940	0.0000	11,710.4080	11,710.4080	0.9617	0.0000	11,734.4497
2024	237.0656	9.5503	14.9372	0.0238	1.2171	0.4694	1.2875	0.3229	0.4319	0.4621	0.0000	2,307.0517	2,307.0517	0.7164	0.0000	2,324.9627
Maximum	237.0656	46.4460	39.6338	0.1195	18.2032	2.0456	20.2488	9.9670	1.8820	11.8490	0.0000	12,035.3440	12,035.3440	1.9482	0.0000	12,060.6013

Village South Specific Plan (Proposed) - Los Angeles-South Coast County, Winter

2.2 Overall Operational

Unmitigated Operational

	ROG	NOx	CO	SO2	Fugitive PM10	Exhaust PM10	PM10 Total	Fugitive PM2.5	Exhaust PM2.5	PM2.5 Total	Bio- CO2	NBio- CO2	Total CO2	CH4	N2O	CO2e
Category	lb/day										lb/day					
Area	30.5020	15.0496	88.4430	0.0944		1.5974	1.5974		1.5974	1.5974	0.0000	18,148.5950	18,148.5950	0.4874	0.3300	18,259.1192
Energy	0.7660	6.7462	4.2573	0.0418		0.5292	0.5292		0.5292	0.5292		8,355.9832	8,355.9832	0.1602	0.1532	8,405.6387
Mobile	9.5233	45.9914	110.0422	0.4681	45.9592	0.3373	46.2965	12.2950	0.3132	12.6083		47,917.8005	47,917.8005	2.1953		47,972.6839
Total	40.7912	67.7872	202.7424	0.6043	45.9592	2.4640	48.4231	12.2950	2.4399	14.7349	0.0000	74,422.3787	74,422.3787	2.8429	0.4832	74,637.4417

Mitigated Operational

	ROG	NOx	CO	SO2	Fugitive PM10	Exhaust PM10	PM10 Total	Fugitive PM2.5	Exhaust PM2.5	PM2.5 Total	Bio- CO2	NBio- CO2	Total CO2	CH4	N2O	CO2e
Category	lb/day										lb/day					
Area	30.5020	15.0496	88.4430	0.0944		1.5974	1.5974		1.5974	1.5974	0.0000	18,148.5950	18,148.5950	0.4874	0.3300	18,259.1192
Energy	0.7660	6.7462	4.2573	0.0418		0.5292	0.5292		0.5292	0.5292		8,355.9832	8,355.9832	0.1602	0.1532	8,405.6387
Mobile	9.5233	45.9914	110.0422	0.4681	45.9592	0.3373	46.2965	12.2950	0.3132	12.6083		47,917.8005	47,917.8005	2.1953		47,972.6839
Total	40.7912	67.7872	202.7424	0.6043	45.9592	2.4640	48.4231	12.2950	2.4399	14.7349	0.0000	74,422.3787	74,422.3787	2.8429	0.4832	74,637.4417

Village South Specific Plan (Proposed) - Los Angeles-South Coast County, Winter

	ROG	NOx	CO	SO2	Fugitive PM10	Exhaust PM10	PM10 Total	Fugitive PM2.5	Exhaust PM2.5	PM2.5 Total	Bio- CO2	NBio-CO2	Total CO2	CH4	N2O	CO2e
Percent Reduction	0.00	0.00	0.00	0.00	0.00	0.00	0.00	0.00	0.00	0.00	0.00	0.00	0.00	0.00	0.00	0.00

3.0 Construction Detail

Construction Phase

Phase Number	Phase Name	Phase Type	Start Date	End Date	Num Days Week	Num Days	Phase Description
1	Demolition	Demolition	9/1/2021	10/12/2021	5	30	
2	Site Preparation	Site Preparation	10/13/2021	11/9/2021	5	20	
3	Grading	Grading	11/10/2021	1/11/2022	5	45	
4	Building Construction	Building Construction	1/12/2022	12/12/2023	5	500	
5	Paving	Paving	12/13/2023	1/30/2024	5	35	
6	Architectural Coating	Architectural Coating	1/31/2024	3/19/2024	5	35	

Acres of Grading (Site Preparation Phase): 0

Acres of Grading (Grading Phase): 112.5

Acres of Paving: 0

Residential Indoor: 2,025,000; Residential Outdoor: 675,000; Non-Residential Indoor: 326,400; Non-Residential Outdoor: 108,800; Striped Parking Area: 0 (Architectural Coating – sqft)

OffRoad Equipment

Village South Specific Plan (Proposed) - Los Angeles-South Coast County, Winter

Phase Name	Offroad Equipment Type	Amount	Usage Hours	Horse Power	Load Factor
Demolition	Concrete/Industrial Saws	1	8.00	81	0.73
Demolition	Excavators	3	8.00	158	0.38
Demolition	Rubber Tired Dozers	2	8.00	247	0.40
Site Preparation	Rubber Tired Dozers	3	8.00	247	0.40
Site Preparation	Tractors/Loaders/Backhoes	4	8.00	97	0.37
Grading	Excavators	2	8.00	158	0.38
Grading	Graders	1	8.00	187	0.41
Grading	Rubber Tired Dozers	1	8.00	247	0.40
Grading	Scrapers	2	8.00	367	0.48
Grading	Tractors/Loaders/Backhoes	2	8.00	97	0.37
Building Construction	Cranes	1	7.00	231	0.29
Building Construction	Forklifts	3	8.00	89	0.20
Building Construction	Generator Sets	1	8.00	84	0.74
Building Construction	Tractors/Loaders/Backhoes	3	7.00	97	0.37
Building Construction	Welders	1	8.00	46	0.45
Paving	Pavers	2	8.00	130	0.42
Paving	Paving Equipment	2	8.00	132	0.36
Paving	Rollers	2	8.00	80	0.38
Architectural Coating	Air Compressors	1	6.00	78	0.48

Trips and VMT

Village South Specific Plan (Proposed) - Los Angeles-South Coast County, Winter

Phase Name	Offroad Equipment Count	Worker Trip Number	Vendor Trip Number	Hauling Trip Number	Worker Trip Length	Vendor Trip Length	Hauling Trip Length	Worker Vehicle Class	Vendor Vehicle Class	Hauling Vehicle Class
Demolition	6	15.00	0.00	458.00	10.00	6.90	20.00	LD_Mix	HDT_Mix	HHDT
Site Preparation	7	18.00	0.00	0.00	10.00	6.90	20.00	LD_Mix	HDT_Mix	HHDT
Grading	8	20.00	0.00	0.00	10.00	6.90	20.00	LD_Mix	HDT_Mix	HHDT
Building Construction	9	801.00	143.00	0.00	10.00	6.90	20.00	LD_Mix	HDT_Mix	HHDT
Paving	6	15.00	0.00	0.00	10.00	6.90	20.00	LD_Mix	HDT_Mix	HHDT
Architectural Coating	1	160.00	0.00	0.00	10.00	6.90	20.00	LD_Mix	HDT_Mix	HHDT

3.1 Mitigation Measures Construction

3.2 Demolition - 2021

Unmitigated Construction On-Site

	ROG	NOx	CO	SO2	Fugitive PM10	Exhaust PM10	PM10 Total	Fugitive PM2.5	Exhaust PM2.5	PM2.5 Total	Bio- CO2	NBio- CO2	Total CO2	CH4	N2O	CO2e
Category	lb/day										lb/day					
Fugitive Dust					3.3074	0.0000	3.3074	0.5008	0.0000	0.5008			0.0000			0.0000
Off-Road	3.1651	31.4407	21.5650	0.0388		1.5513	1.5513		1.4411	1.4411		3,747.9449	3,747.9449	1.0549		3,774.3174
Total	3.1651	31.4407	21.5650	0.0388	3.3074	1.5513	4.8588	0.5008	1.4411	1.9419		3,747.9449	3,747.9449	1.0549		3,774.3174

Village South Specific Plan (Proposed) - Los Angeles-South Coast County, Winter

3.2 Demolition - 2021

Unmitigated Construction Off-Site

	ROG	NOx	CO	SO2	Fugitive PM10	Exhaust PM10	PM10 Total	Fugitive PM2.5	Exhaust PM2.5	PM2.5 Total	Bio- CO2	NBio- CO2	Total CO2	CH4	N2O	CO2e
Category	lb/day										lb/day					
Hauling	0.1304	4.1454	1.0182	0.0117	0.2669	0.0128	0.2797	0.0732	0.0122	0.0854		1,269.8555	1,269.8555	0.0908		1,272.1252
Vendor	0.0000	0.0000	0.0000	0.0000	0.0000	0.0000	0.0000	0.0000	0.0000	0.0000		0.0000	0.0000	0.0000		0.0000
Worker	0.0532	0.0346	0.3963	1.1100e-003	0.1141	9.5000e-004	0.1151	0.0303	8.8000e-004	0.0311		110.4707	110.4707	3.3300e-003		110.5539
Total	0.1835	4.1800	1.4144	0.0128	0.3810	0.0137	0.3948	0.1034	0.0131	0.1165		1,380.3262	1,380.3262	0.0941		1,382.6791

Mitigated Construction On-Site

	ROG	NOx	CO	SO2	Fugitive PM10	Exhaust PM10	PM10 Total	Fugitive PM2.5	Exhaust PM2.5	PM2.5 Total	Bio- CO2	NBio- CO2	Total CO2	CH4	N2O	CO2e
Category	lb/day										lb/day					
Fugitive Dust					3.3074	0.0000	3.3074	0.5008	0.0000	0.5008			0.0000			0.0000
Off-Road	3.1651	31.4407	21.5650	0.0388		1.5513	1.5513		1.4411	1.4411	0.0000	3,747.9449	3,747.9449	1.0549		3,774.3174
Total	3.1651	31.4407	21.5650	0.0388	3.3074	1.5513	4.8588	0.5008	1.4411	1.9419	0.0000	3,747.9449	3,747.9449	1.0549		3,774.3174

Village South Specific Plan (Proposed) - Los Angeles-South Coast County, Winter

3.2 Demolition - 2021

Mitigated Construction Off-Site

	ROG	NOx	CO	SO2	Fugitive PM10	Exhaust PM10	PM10 Total	Fugitive PM2.5	Exhaust PM2.5	PM2.5 Total	Bio- CO2	NBio- CO2	Total CO2	CH4	N2O	CO2e
Category	lb/day										lb/day					
Hauling	0.1304	4.1454	1.0182	0.0117	0.2669	0.0128	0.2797	0.0732	0.0122	0.0854		1,269.8555	1,269.8555	0.0908		1,272.1252
Vendor	0.0000	0.0000	0.0000	0.0000	0.0000	0.0000	0.0000	0.0000	0.0000	0.0000		0.0000	0.0000	0.0000		0.0000
Worker	0.0532	0.0346	0.3963	1.1100e-003	0.1141	9.5000e-004	0.1151	0.0303	8.8000e-004	0.0311		110.4707	110.4707	3.3300e-003		110.5539
Total	0.1835	4.1800	1.4144	0.0128	0.3810	0.0137	0.3948	0.1034	0.0131	0.1165		1,380.3262	1,380.3262	0.0941		1,382.6791

3.3 Site Preparation - 2021

Unmitigated Construction On-Site

	ROG	NOx	CO	SO2	Fugitive PM10	Exhaust PM10	PM10 Total	Fugitive PM2.5	Exhaust PM2.5	PM2.5 Total	Bio- CO2	NBio- CO2	Total CO2	CH4	N2O	CO2e
Category	lb/day										lb/day					
Fugitive Dust					18.0663	0.0000	18.0663	9.9307	0.0000	9.9307			0.0000			0.0000
Off-Road	3.8882	40.4971	21.1543	0.0380		2.0445	2.0445		1.8809	1.8809		3,685.6569	3,685.6569	1.1920		3,715.4573
Total	3.8882	40.4971	21.1543	0.0380	18.0663	2.0445	20.1107	9.9307	1.8809	11.8116		3,685.6569	3,685.6569	1.1920		3,715.4573

Village South Specific Plan (Proposed) - Los Angeles-South Coast County, Winter

3.3 Site Preparation - 2021

Unmitigated Construction Off-Site

	ROG	NOx	CO	SO2	Fugitive PM10	Exhaust PM10	PM10 Total	Fugitive PM2.5	Exhaust PM2.5	PM2.5 Total	Bio- CO2	NBio- CO2	Total CO2	CH4	N2O	CO2e
Category	lb/day										lb/day					
Hauling	0.0000	0.0000	0.0000	0.0000	0.0000	0.0000	0.0000	0.0000	0.0000	0.0000		0.0000	0.0000	0.0000		0.0000
Vendor	0.0000	0.0000	0.0000	0.0000	0.0000	0.0000	0.0000	0.0000	0.0000	0.0000		0.0000	0.0000	0.0000		0.0000
Worker	0.0638	0.0415	0.4755	1.3300e-003	0.1369	1.1400e-003	0.1381	0.0363	1.0500e-003	0.0374		132.5649	132.5649	3.9900e-003		132.6646
Total	0.0638	0.0415	0.4755	1.3300e-003	0.1369	1.1400e-003	0.1381	0.0363	1.0500e-003	0.0374		132.5649	132.5649	3.9900e-003		132.6646

Mitigated Construction On-Site

	ROG	NOx	CO	SO2	Fugitive PM10	Exhaust PM10	PM10 Total	Fugitive PM2.5	Exhaust PM2.5	PM2.5 Total	Bio- CO2	NBio- CO2	Total CO2	CH4	N2O	CO2e
Category	lb/day										lb/day					
Fugitive Dust					18.0663	0.0000	18.0663	9.9307	0.0000	9.9307			0.0000			0.0000
Off-Road	3.8882	40.4971	21.1543	0.0380		2.0445	2.0445		1.8809	1.8809	0.0000	3,685.6569	3,685.6569	1.1920		3,715.4573
Total	3.8882	40.4971	21.1543	0.0380	18.0663	2.0445	20.1107	9.9307	1.8809	11.8116	0.0000	3,685.6569	3,685.6569	1.1920		3,715.4573

Village South Specific Plan (Proposed) - Los Angeles-South Coast County, Winter

3.3 Site Preparation - 2021

Mitigated Construction Off-Site

	ROG	NOx	CO	SO2	Fugitive PM10	Exhaust PM10	PM10 Total	Fugitive PM2.5	Exhaust PM2.5	PM2.5 Total	Bio- CO2	NBio- CO2	Total CO2	CH4	N2O	CO2e
Category	lb/day										lb/day					
Hauling	0.0000	0.0000	0.0000	0.0000	0.0000	0.0000	0.0000	0.0000	0.0000	0.0000		0.0000	0.0000	0.0000		0.0000
Vendor	0.0000	0.0000	0.0000	0.0000	0.0000	0.0000	0.0000	0.0000	0.0000	0.0000		0.0000	0.0000	0.0000		0.0000
Worker	0.0638	0.0415	0.4755	1.3300e-003	0.1369	1.1400e-003	0.1381	0.0363	1.0500e-003	0.0374		132.5649	132.5649	3.9900e-003		132.6646
Total	0.0638	0.0415	0.4755	1.3300e-003	0.1369	1.1400e-003	0.1381	0.0363	1.0500e-003	0.0374		132.5649	132.5649	3.9900e-003		132.6646

3.4 Grading - 2021

Unmitigated Construction On-Site

	ROG	NOx	CO	SO2	Fugitive PM10	Exhaust PM10	PM10 Total	Fugitive PM2.5	Exhaust PM2.5	PM2.5 Total	Bio- CO2	NBio- CO2	Total CO2	CH4	N2O	CO2e
Category	lb/day										lb/day					
Fugitive Dust					8.6733	0.0000	8.6733	3.5965	0.0000	3.5965			0.0000			0.0000
Off-Road	4.1912	46.3998	30.8785	0.0620		1.9853	1.9853		1.8265	1.8265		6,007.0434	6,007.0434	1.9428		6,055.6134
Total	4.1912	46.3998	30.8785	0.0620	8.6733	1.9853	10.6587	3.5965	1.8265	5.4230		6,007.0434	6,007.0434	1.9428		6,055.6134

Village South Specific Plan (Proposed) - Los Angeles-South Coast County, Winter

3.4 Grading - 2021

Unmitigated Construction Off-Site

	ROG	NOx	CO	SO2	Fugitive PM10	Exhaust PM10	PM10 Total	Fugitive PM2.5	Exhaust PM2.5	PM2.5 Total	Bio- CO2	NBio- CO2	Total CO2	CH4	N2O	CO2e
Category	lb/day										lb/day					
Hauling	0.0000	0.0000	0.0000	0.0000	0.0000	0.0000	0.0000	0.0000	0.0000	0.0000		0.0000	0.0000	0.0000		0.0000
Vendor	0.0000	0.0000	0.0000	0.0000	0.0000	0.0000	0.0000	0.0000	0.0000	0.0000		0.0000	0.0000	0.0000		0.0000
Worker	0.0709	0.0462	0.5284	1.4800e-003	0.1521	1.2700e-003	0.1534	0.0404	1.1700e-003	0.0415		147.2943	147.2943	4.4300e-003		147.4051
Total	0.0709	0.0462	0.5284	1.4800e-003	0.1521	1.2700e-003	0.1534	0.0404	1.1700e-003	0.0415		147.2943	147.2943	4.4300e-003		147.4051

Mitigated Construction On-Site

	ROG	NOx	CO	SO2	Fugitive PM10	Exhaust PM10	PM10 Total	Fugitive PM2.5	Exhaust PM2.5	PM2.5 Total	Bio- CO2	NBio- CO2	Total CO2	CH4	N2O	CO2e
Category	lb/day										lb/day					
Fugitive Dust					8.6733	0.0000	8.6733	3.5965	0.0000	3.5965			0.0000			0.0000
Off-Road	4.1912	46.3998	30.8785	0.0620		1.9853	1.9853		1.8265	1.8265	0.0000	6,007.0434	6,007.0434	1.9428		6,055.6134
Total	4.1912	46.3998	30.8785	0.0620	8.6733	1.9853	10.6587	3.5965	1.8265	5.4230	0.0000	6,007.0434	6,007.0434	1.9428		6,055.6134

Village South Specific Plan (Proposed) - Los Angeles-South Coast County, Winter

3.4 Grading - 2021

Mitigated Construction Off-Site

	ROG	NOx	CO	SO2	Fugitive PM10	Exhaust PM10	PM10 Total	Fugitive PM2.5	Exhaust PM2.5	PM2.5 Total	Bio- CO2	NBio- CO2	Total CO2	CH4	N2O	CO2e
Category	lb/day										lb/day					
Hauling	0.0000	0.0000	0.0000	0.0000	0.0000	0.0000	0.0000	0.0000	0.0000	0.0000		0.0000	0.0000	0.0000		0.0000
Vendor	0.0000	0.0000	0.0000	0.0000	0.0000	0.0000	0.0000	0.0000	0.0000	0.0000		0.0000	0.0000	0.0000		0.0000
Worker	0.0709	0.0462	0.5284	1.4800e-003	0.1521	1.2700e-003	0.1534	0.0404	1.1700e-003	0.0415		147.2943	147.2943	4.4300e-003		147.4051
Total	0.0709	0.0462	0.5284	1.4800e-003	0.1521	1.2700e-003	0.1534	0.0404	1.1700e-003	0.0415		147.2943	147.2943	4.4300e-003		147.4051

3.4 Grading - 2022

Unmitigated Construction On-Site

	ROG	NOx	CO	SO2	Fugitive PM10	Exhaust PM10	PM10 Total	Fugitive PM2.5	Exhaust PM2.5	PM2.5 Total	Bio- CO2	NBio- CO2	Total CO2	CH4	N2O	CO2e
Category	lb/day										lb/day					
Fugitive Dust					8.6733	0.0000	8.6733	3.5965	0.0000	3.5965			0.0000			0.0000
Off-Road	3.6248	38.8435	29.0415	0.0621		1.6349	1.6349		1.5041	1.5041		6,011.4105	6,011.4105	1.9442		6,060.0158
Total	3.6248	38.8435	29.0415	0.0621	8.6733	1.6349	10.3082	3.5965	1.5041	5.1006		6,011.4105	6,011.4105	1.9442		6,060.0158

Village South Specific Plan (Proposed) - Los Angeles-South Coast County, Winter

3.4 Grading - 2022

Unmitigated Construction Off-Site

	ROG	NOx	CO	SO2	Fugitive PM10	Exhaust PM10	PM10 Total	Fugitive PM2.5	Exhaust PM2.5	PM2.5 Total	Bio- CO2	NBio- CO2	Total CO2	CH4	N2O	CO2e
Category	lb/day										lb/day					
Hauling	0.0000	0.0000	0.0000	0.0000	0.0000	0.0000	0.0000	0.0000	0.0000	0.0000		0.0000	0.0000	0.0000		0.0000
Vendor	0.0000	0.0000	0.0000	0.0000	0.0000	0.0000	0.0000	0.0000	0.0000	0.0000		0.0000	0.0000	0.0000		0.0000
Worker	0.0665	0.0416	0.4861	1.4300e-003	0.1521	1.2300e-003	0.1534	0.0404	1.1300e-003	0.0415		142.1207	142.1207	4.0000e-003		142.2207
Total	0.0665	0.0416	0.4861	1.4300e-003	0.1521	1.2300e-003	0.1534	0.0404	1.1300e-003	0.0415		142.1207	142.1207	4.0000e-003		142.2207

Mitigated Construction On-Site

	ROG	NOx	CO	SO2	Fugitive PM10	Exhaust PM10	PM10 Total	Fugitive PM2.5	Exhaust PM2.5	PM2.5 Total	Bio- CO2	NBio- CO2	Total CO2	CH4	N2O	CO2e
Category	lb/day										lb/day					
Fugitive Dust					8.6733	0.0000	8.6733	3.5965	0.0000	3.5965			0.0000			0.0000
Off-Road	3.6248	38.8435	29.0415	0.0621		1.6349	1.6349		1.5041	1.5041	0.0000	6,011.4105	6,011.4105	1.9442		6,060.0158
Total	3.6248	38.8435	29.0415	0.0621	8.6733	1.6349	10.3082	3.5965	1.5041	5.1006	0.0000	6,011.4105	6,011.4105	1.9442		6,060.0158

Village South Specific Plan (Proposed) - Los Angeles-South Coast County, Winter

3.4 Grading - 2022

Mitigated Construction Off-Site

	ROG	NOx	CO	SO2	Fugitive PM10	Exhaust PM10	PM10 Total	Fugitive PM2.5	Exhaust PM2.5	PM2.5 Total	Bio- CO2	NBio- CO2	Total CO2	CH4	N2O	CO2e
Category	lb/day										lb/day					
Hauling	0.0000	0.0000	0.0000	0.0000	0.0000	0.0000	0.0000	0.0000	0.0000	0.0000		0.0000	0.0000	0.0000		0.0000
Vendor	0.0000	0.0000	0.0000	0.0000	0.0000	0.0000	0.0000	0.0000	0.0000	0.0000		0.0000	0.0000	0.0000		0.0000
Worker	0.0665	0.0416	0.4861	1.4300e-003	0.1521	1.2300e-003	0.1534	0.0404	1.1300e-003	0.0415		142.1207	142.1207	4.0000e-003		142.2207
Total	0.0665	0.0416	0.4861	1.4300e-003	0.1521	1.2300e-003	0.1534	0.0404	1.1300e-003	0.0415		142.1207	142.1207	4.0000e-003		142.2207

3.5 Building Construction - 2022

Unmitigated Construction On-Site

	ROG	NOx	CO	SO2	Fugitive PM10	Exhaust PM10	PM10 Total	Fugitive PM2.5	Exhaust PM2.5	PM2.5 Total	Bio- CO2	NBio- CO2	Total CO2	CH4	N2O	CO2e
Category	lb/day										lb/day					
Off-Road	1.7062	15.6156	16.3634	0.0269		0.8090	0.8090		0.7612	0.7612		2,554.3336	2,554.3336	0.6120		2,569.6322
Total	1.7062	15.6156	16.3634	0.0269		0.8090	0.8090		0.7612	0.7612		2,554.3336	2,554.3336	0.6120		2,569.6322

Village South Specific Plan (Proposed) - Los Angeles-South Coast County, Winter

3.5 Building Construction - 2022

Unmitigated Construction Off-Site

	ROG	NOx	CO	SO2	Fugitive PM10	Exhaust PM10	PM10 Total	Fugitive PM2.5	Exhaust PM2.5	PM2.5 Total	Bio- CO2	NBio- CO2	Total CO2	CH4	N2O	CO2e
Category	lb/day										lb/day					
Hauling	0.0000	0.0000	0.0000	0.0000	0.0000	0.0000	0.0000	0.0000	0.0000	0.0000		0.0000	0.0000	0.0000		0.0000
Vendor	0.4284	13.1673	3.8005	0.0354	0.9155	0.0256	0.9412	0.2636	0.0245	0.2881		3,789.0750	3,789.0750	0.2381		3,795.0283
Worker	2.6620	1.6677	19.4699	0.0571	6.0932	0.0493	6.1425	1.6163	0.0454	1.6617		5,691.9354	5,691.9354	0.1602		5,695.9408
Total	3.0904	14.8350	23.2704	0.0926	7.0087	0.0749	7.0836	1.8799	0.0699	1.9498		9,481.0104	9,481.0104	0.3984		9,490.9691

Mitigated Construction On-Site

	ROG	NOx	CO	SO2	Fugitive PM10	Exhaust PM10	PM10 Total	Fugitive PM2.5	Exhaust PM2.5	PM2.5 Total	Bio- CO2	NBio- CO2	Total CO2	CH4	N2O	CO2e
Category	lb/day										lb/day					
Off-Road	1.7062	15.6156	16.3634	0.0269		0.8090	0.8090		0.7612	0.7612	0.0000	2,554.3336	2,554.3336	0.6120		2,569.6322
Total	1.7062	15.6156	16.3634	0.0269		0.8090	0.8090		0.7612	0.7612	0.0000	2,554.3336	2,554.3336	0.6120		2,569.6322

Village South Specific Plan (Proposed) - Los Angeles-South Coast County, Winter

3.5 Building Construction - 2022

Mitigated Construction Off-Site

	ROG	NOx	CO	SO2	Fugitive PM10	Exhaust PM10	PM10 Total	Fugitive PM2.5	Exhaust PM2.5	PM2.5 Total	Bio- CO2	NBio- CO2	Total CO2	CH4	N2O	CO2e
Category	lb/day										lb/day					
Hauling	0.0000	0.0000	0.0000	0.0000	0.0000	0.0000	0.0000	0.0000	0.0000	0.0000		0.0000	0.0000	0.0000		0.0000
Vendor	0.4284	13.1673	3.8005	0.0354	0.9155	0.0256	0.9412	0.2636	0.0245	0.2881		3,789.0750	3,789.0750	0.2381		3,795.0283
Worker	2.6620	1.6677	19.4699	0.0571	6.0932	0.0493	6.1425	1.6163	0.0454	1.6617		5,691.9354	5,691.9354	0.1602		5,695.9408
Total	3.0904	14.8350	23.2704	0.0926	7.0087	0.0749	7.0836	1.8799	0.0699	1.9498		9,481.0104	9,481.0104	0.3984		9,490.9691

3.5 Building Construction - 2023

Unmitigated Construction On-Site

	ROG	NOx	CO	SO2	Fugitive PM10	Exhaust PM10	PM10 Total	Fugitive PM2.5	Exhaust PM2.5	PM2.5 Total	Bio- CO2	NBio- CO2	Total CO2	CH4	N2O	CO2e
Category	lb/day										lb/day					
Off-Road	1.5728	14.3849	16.2440	0.0269		0.6997	0.6997		0.6584	0.6584		2,555.2099	2,555.2099	0.6079		2,570.4061
Total	1.5728	14.3849	16.2440	0.0269		0.6997	0.6997		0.6584	0.6584		2,555.2099	2,555.2099	0.6079		2,570.4061

Village South Specific Plan (Proposed) - Los Angeles-South Coast County, Winter

3.5 Building Construction - 2023

Unmitigated Construction Off-Site

	ROG	NOx	CO	SO2	Fugitive PM10	Exhaust PM10	PM10 Total	Fugitive PM2.5	Exhaust PM2.5	PM2.5 Total	Bio- CO2	NBio- CO2	Total CO2	CH4	N2O	CO2e
Category	lb/day										lb/day					
Hauling	0.0000	0.0000	0.0000	0.0000	0.0000	0.0000	0.0000	0.0000	0.0000	0.0000		0.0000	0.0000	0.0000		0.0000
Vendor	0.3183	9.9726	3.3771	0.0343	0.9156	0.0122	0.9277	0.2636	0.0116	0.2752		3,671.4007	3,671.4007	0.2096		3,676.6417
Worker	2.5029	1.5073	17.8820	0.0550	6.0932	0.0479	6.1411	1.6163	0.0441	1.6604		5,483.7974	5,483.7974	0.1442		5,487.4020
Total	2.8211	11.4799	21.2591	0.0893	7.0088	0.0601	7.0688	1.8799	0.0557	1.9356		9,155.1981	9,155.1981	0.3538		9,164.0437

Mitigated Construction On-Site

	ROG	NOx	CO	SO2	Fugitive PM10	Exhaust PM10	PM10 Total	Fugitive PM2.5	Exhaust PM2.5	PM2.5 Total	Bio- CO2	NBio- CO2	Total CO2	CH4	N2O	CO2e
Category	lb/day										lb/day					
Off-Road	1.5728	14.3849	16.2440	0.0269		0.6997	0.6997		0.6584	0.6584	0.0000	2,555.2099	2,555.2099	0.6079		2,570.4061
Total	1.5728	14.3849	16.2440	0.0269		0.6997	0.6997		0.6584	0.6584	0.0000	2,555.2099	2,555.2099	0.6079		2,570.4061

Village South Specific Plan (Proposed) - Los Angeles-South Coast County, Winter

3.5 Building Construction - 2023

Mitigated Construction Off-Site

	ROG	NOx	CO	SO2	Fugitive PM10	Exhaust PM10	PM10 Total	Fugitive PM2.5	Exhaust PM2.5	PM2.5 Total	Bio- CO2	NBio- CO2	Total CO2	CH4	N2O	CO2e
Category	lb/day										lb/day					
Hauling	0.0000	0.0000	0.0000	0.0000	0.0000	0.0000	0.0000	0.0000	0.0000	0.0000		0.0000	0.0000	0.0000		0.0000
Vendor	0.3183	9.9726	3.3771	0.0343	0.9156	0.0122	0.9277	0.2636	0.0116	0.2752		3,671.4007	3,671.4007	0.2096		3,676.6417
Worker	2.5029	1.5073	17.8820	0.0550	6.0932	0.0479	6.1411	1.6163	0.0441	1.6604		5,483.7974	5,483.7974	0.1442		5,487.4020
Total	2.8211	11.4799	21.2591	0.0893	7.0088	0.0601	7.0688	1.8799	0.0557	1.9356		9,155.1981	9,155.1981	0.3538		9,164.0437

3.6 Paving - 2023

Unmitigated Construction On-Site

	ROG	NOx	CO	SO2	Fugitive PM10	Exhaust PM10	PM10 Total	Fugitive PM2.5	Exhaust PM2.5	PM2.5 Total	Bio- CO2	NBio- CO2	Total CO2	CH4	N2O	CO2e
Category	lb/day										lb/day					
Off-Road	1.0327	10.1917	14.5842	0.0228		0.5102	0.5102		0.4694	0.4694		2,207.5841	2,207.5841	0.7140		2,225.4336
Paving	0.0000					0.0000	0.0000		0.0000	0.0000			0.0000			0.0000
Total	1.0327	10.1917	14.5842	0.0228		0.5102	0.5102		0.4694	0.4694		2,207.5841	2,207.5841	0.7140		2,225.4336

Village South Specific Plan (Proposed) - Los Angeles-South Coast County, Winter

3.6 Paving - 2023

Unmitigated Construction Off-Site

	ROG	NOx	CO	SO2	Fugitive PM10	Exhaust PM10	PM10 Total	Fugitive PM2.5	Exhaust PM2.5	PM2.5 Total	Bio- CO2	NBio- CO2	Total CO2	CH4	N2O	CO2e
Category	lb/day										lb/day					
Hauling	0.0000	0.0000	0.0000	0.0000	0.0000	0.0000	0.0000	0.0000	0.0000	0.0000		0.0000	0.0000	0.0000		0.0000
Vendor	0.0000	0.0000	0.0000	0.0000	0.0000	0.0000	0.0000	0.0000	0.0000	0.0000		0.0000	0.0000	0.0000		0.0000
Worker	0.0469	0.0282	0.3349	1.0300e-003	0.1141	9.0000e-004	0.1150	0.0303	8.3000e-004	0.0311		102.6928	102.6928	2.7000e-003		102.7603
Total	0.0469	0.0282	0.3349	1.0300e-003	0.1141	9.0000e-004	0.1150	0.0303	8.3000e-004	0.0311		102.6928	102.6928	2.7000e-003		102.7603

Mitigated Construction On-Site

	ROG	NOx	CO	SO2	Fugitive PM10	Exhaust PM10	PM10 Total	Fugitive PM2.5	Exhaust PM2.5	PM2.5 Total	Bio- CO2	NBio- CO2	Total CO2	CH4	N2O	CO2e
Category	lb/day										lb/day					
Off-Road	1.0327	10.1917	14.5842	0.0228		0.5102	0.5102		0.4694	0.4694	0.0000	2,207.5841	2,207.5841	0.7140		2,225.4336
Paving	0.0000					0.0000	0.0000		0.0000	0.0000			0.0000			0.0000
Total	1.0327	10.1917	14.5842	0.0228		0.5102	0.5102		0.4694	0.4694	0.0000	2,207.5841	2,207.5841	0.7140		2,225.4336

Village South Specific Plan (Proposed) - Los Angeles-South Coast County, Winter

3.6 Paving - 2023

Mitigated Construction Off-Site

	ROG	NOx	CO	SO2	Fugitive PM10	Exhaust PM10	PM10 Total	Fugitive PM2.5	Exhaust PM2.5	PM2.5 Total	Bio- CO2	NBio- CO2	Total CO2	CH4	N2O	CO2e
Category	lb/day										lb/day					
Hauling	0.0000	0.0000	0.0000	0.0000	0.0000	0.0000	0.0000	0.0000	0.0000	0.0000		0.0000	0.0000	0.0000		0.0000
Vendor	0.0000	0.0000	0.0000	0.0000	0.0000	0.0000	0.0000	0.0000	0.0000	0.0000		0.0000	0.0000	0.0000		0.0000
Worker	0.0469	0.0282	0.3349	1.0300e-003	0.1141	9.0000e-004	0.1150	0.0303	8.3000e-004	0.0311		102.6928	102.6928	2.7000e-003		102.7603
Total	0.0469	0.0282	0.3349	1.0300e-003	0.1141	9.0000e-004	0.1150	0.0303	8.3000e-004	0.0311		102.6928	102.6928	2.7000e-003		102.7603

3.6 Paving - 2024

Unmitigated Construction On-Site

	ROG	NOx	CO	SO2	Fugitive PM10	Exhaust PM10	PM10 Total	Fugitive PM2.5	Exhaust PM2.5	PM2.5 Total	Bio- CO2	NBio- CO2	Total CO2	CH4	N2O	CO2e
Category	lb/day										lb/day					
Off-Road	0.9882	9.5246	14.6258	0.0228		0.4685	0.4685		0.4310	0.4310		2,207.5472	2,207.5472	0.7140		2,225.3963
Paving	0.0000					0.0000	0.0000		0.0000	0.0000			0.0000			0.0000
Total	0.9882	9.5246	14.6258	0.0228		0.4685	0.4685		0.4310	0.4310		2,207.5472	2,207.5472	0.7140		2,225.3963

Village South Specific Plan (Proposed) - Los Angeles-South Coast County, Winter

3.6 Paving - 2024

Unmitigated Construction Off-Site

	ROG	NOx	CO	SO2	Fugitive PM10	Exhaust PM10	PM10 Total	Fugitive PM2.5	Exhaust PM2.5	PM2.5 Total	Bio- CO2	NBio- CO2	Total CO2	CH4	N2O	CO2e
Category	lb/day										lb/day					
Hauling	0.0000	0.0000	0.0000	0.0000	0.0000	0.0000	0.0000	0.0000	0.0000	0.0000		0.0000	0.0000	0.0000		0.0000
Vendor	0.0000	0.0000	0.0000	0.0000	0.0000	0.0000	0.0000	0.0000	0.0000	0.0000		0.0000	0.0000	0.0000		0.0000
Worker	0.0444	0.0257	0.3114	1.0000e-003	0.1141	8.8000e-004	0.1150	0.0303	8.1000e-004	0.0311		99.5045	99.5045	2.4700e-003		99.5663
Total	0.0444	0.0257	0.3114	1.0000e-003	0.1141	8.8000e-004	0.1150	0.0303	8.1000e-004	0.0311		99.5045	99.5045	2.4700e-003		99.5663

Mitigated Construction On-Site

	ROG	NOx	CO	SO2	Fugitive PM10	Exhaust PM10	PM10 Total	Fugitive PM2.5	Exhaust PM2.5	PM2.5 Total	Bio- CO2	NBio- CO2	Total CO2	CH4	N2O	CO2e
Category	lb/day										lb/day					
Off-Road	0.9882	9.5246	14.6258	0.0228		0.4685	0.4685		0.4310	0.4310	0.0000	2,207.5472	2,207.5472	0.7140		2,225.3963
Paving	0.0000					0.0000	0.0000		0.0000	0.0000			0.0000			0.0000
Total	0.9882	9.5246	14.6258	0.0228		0.4685	0.4685		0.4310	0.4310	0.0000	2,207.5472	2,207.5472	0.7140		2,225.3963

Village South Specific Plan (Proposed) - Los Angeles-South Coast County, Winter

3.6 Paving - 2024

Mitigated Construction Off-Site

	ROG	NOx	CO	SO2	Fugitive PM10	Exhaust PM10	PM10 Total	Fugitive PM2.5	Exhaust PM2.5	PM2.5 Total	Bio- CO2	NBio- CO2	Total CO2	CH4	N2O	CO2e
Category	lb/day										lb/day					
Hauling	0.0000	0.0000	0.0000	0.0000	0.0000	0.0000	0.0000	0.0000	0.0000	0.0000		0.0000	0.0000	0.0000		0.0000
Vendor	0.0000	0.0000	0.0000	0.0000	0.0000	0.0000	0.0000	0.0000	0.0000	0.0000		0.0000	0.0000	0.0000		0.0000
Worker	0.0444	0.0257	0.3114	1.0000e-003	0.1141	8.8000e-004	0.1150	0.0303	8.1000e-004	0.0311		99.5045	99.5045	2.4700e-003		99.5663
Total	0.0444	0.0257	0.3114	1.0000e-003	0.1141	8.8000e-004	0.1150	0.0303	8.1000e-004	0.0311		99.5045	99.5045	2.4700e-003		99.5663

3.7 Architectural Coating - 2024

Unmitigated Construction On-Site

	ROG	NOx	CO	SO2	Fugitive PM10	Exhaust PM10	PM10 Total	Fugitive PM2.5	Exhaust PM2.5	PM2.5 Total	Bio- CO2	NBio- CO2	Total CO2	CH4	N2O	CO2e
Category	lb/day										lb/day					
Archit. Coating	236.4115					0.0000	0.0000		0.0000	0.0000			0.0000			0.0000
Off-Road	0.1808	1.2188	1.8101	2.9700e-003		0.0609	0.0609		0.0609	0.0609		281.4481	281.4481	0.0159		281.8443
Total	236.5923	1.2188	1.8101	2.9700e-003		0.0609	0.0609		0.0609	0.0609		281.4481	281.4481	0.0159		281.8443

Village South Specific Plan (Proposed) - Los Angeles-South Coast County, Winter

3.7 Architectural Coating - 2024

Unmitigated Construction Off-Site

	ROG	NOx	CO	SO2	Fugitive PM10	Exhaust PM10	PM10 Total	Fugitive PM2.5	Exhaust PM2.5	PM2.5 Total	Bio- CO2	NBio- CO2	Total CO2	CH4	N2O	CO2e
Category	lb/day										lb/day					
Hauling	0.0000	0.0000	0.0000	0.0000	0.0000	0.0000	0.0000	0.0000	0.0000	0.0000		0.0000	0.0000	0.0000		0.0000
Vendor	0.0000	0.0000	0.0000	0.0000	0.0000	0.0000	0.0000	0.0000	0.0000	0.0000		0.0000	0.0000	0.0000		0.0000
Worker	0.4734	0.2743	3.3220	0.0107	1.2171	9.4300e-003	1.2266	0.3229	8.6800e-003	0.3315		1,061.3818	1,061.3818	0.0264		1,062.0410
Total	0.4734	0.2743	3.3220	0.0107	1.2171	9.4300e-003	1.2266	0.3229	8.6800e-003	0.3315		1,061.3818	1,061.3818	0.0264		1,062.0410

Mitigated Construction On-Site

	ROG	NOx	CO	SO2	Fugitive PM10	Exhaust PM10	PM10 Total	Fugitive PM2.5	Exhaust PM2.5	PM2.5 Total	Bio- CO2	NBio- CO2	Total CO2	CH4	N2O	CO2e
Category	lb/day										lb/day					
Archit. Coating	236.4115					0.0000	0.0000		0.0000	0.0000			0.0000			0.0000
Off-Road	0.1808	1.2188	1.8101	2.9700e-003		0.0609	0.0609		0.0609	0.0609	0.0000	281.4481	281.4481	0.0159		281.8443
Total	236.5923	1.2188	1.8101	2.9700e-003		0.0609	0.0609		0.0609	0.0609	0.0000	281.4481	281.4481	0.0159		281.8443

Village South Specific Plan (Proposed) - Los Angeles-South Coast County, Winter

3.7 Architectural Coating - 2024

Mitigated Construction Off-Site

	ROG	NOx	CO	SO2	Fugitive PM10	Exhaust PM10	PM10 Total	Fugitive PM2.5	Exhaust PM2.5	PM2.5 Total	Bio- CO2	NBio- CO2	Total CO2	CH4	N2O	CO2e
Category	lb/day										lb/day					
Hauling	0.0000	0.0000	0.0000	0.0000	0.0000	0.0000	0.0000	0.0000	0.0000	0.0000		0.0000	0.0000	0.0000		0.0000
Vendor	0.0000	0.0000	0.0000	0.0000	0.0000	0.0000	0.0000	0.0000	0.0000	0.0000		0.0000	0.0000	0.0000		0.0000
Worker	0.4734	0.2743	3.3220	0.0107	1.2171	9.4300e-003	1.2266	0.3229	8.6800e-003	0.3315		1,061.3818	1,061.3818	0.0264		1,062.0410
Total	0.4734	0.2743	3.3220	0.0107	1.2171	9.4300e-003	1.2266	0.3229	8.6800e-003	0.3315		1,061.3818	1,061.3818	0.0264		1,062.0410

4.0 Operational Detail - Mobile

4.1 Mitigation Measures Mobile

Village South Specific Plan (Proposed) - Los Angeles-South Coast County, Winter

	ROG	NOx	CO	SO2	Fugitive PM10	Exhaust PM10	PM10 Total	Fugitive PM2.5	Exhaust PM2.5	PM2.5 Total	Bio- CO2	NBio- CO2	Total CO2	CH4	N2O	CO2e
Category	lb/day										lb/day					
Mitigated	9.5233	45.9914	110.0422	0.4681	45.9592	0.3373	46.2965	12.2950	0.3132	12.6083		47,917.8005	47,917.8005	2.1953		47,972.6839
Unmitigated	9.5233	45.9914	110.0422	0.4681	45.9592	0.3373	46.2965	12.2950	0.3132	12.6083		47,917.8005	47,917.8005	2.1953		47,972.6839

4.2 Trip Summary Information

Land Use	Average Daily Trip Rate			Unmitigated	Mitigated
	Weekday	Saturday	Sunday	Annual VMT	Annual VMT
Apartments Low Rise	145.75	154.25	154.00	506,227	506,227
Apartments Mid Rise	4,026.75	3,773.25	4075.50	13,660,065	13,660,065
General Office Building	288.45	62.55	31.05	706,812	706,812
High Turnover (Sit Down Restaurant)	2,368.80	2,873.52	2817.72	3,413,937	3,413,937
Hotel	192.00	187.50	160.00	445,703	445,703
Quality Restaurant	501.12	511.92	461.20	707,488	707,488
Regional Shopping Center	528.08	601.44	357.84	1,112,221	1,112,221
Total	8,050.95	8,164.43	8,057.31	20,552,452	20,552,452

4.3 Trip Type Information

Village South Specific Plan (Proposed) - Los Angeles-South Coast County, Winter

Land Use	Miles			Trip %			Trip Purpose %		
	H-W or C-W	H-S or C-C	H-O or C-NW	H-W or C-W	H-S or C-C	H-O or C-NW	Primary	Diverted	Pass-by
Apartments Low Rise	14.70	5.90	8.70	40.20	19.20	40.60	86	11	3
Apartments Mid Rise	14.70	5.90	8.70	40.20	19.20	40.60	86	11	3
General Office Building	16.60	8.40	6.90	33.00	48.00	19.00	77	19	4
High Turnover (Sit Down Restaurant)	16.60	8.40	6.90	8.50	72.50	19.00	37	20	43
Hotel	16.60	8.40	6.90	19.40	61.60	19.00	58	38	4
Quality Restaurant	16.60	8.40	6.90	12.00	69.00	19.00	38	18	44
Regional Shopping Center	16.60	8.40	6.90	16.30	64.70	19.00	54	35	11

4.4 Fleet Mix

Land Use	LDA	LDT1	LDT2	MDV	LHD1	LHD2	MHD	HHD	OBUS	UBUS	MCY	SBUS	MH
Apartments Low Rise	0.543088	0.044216	0.209971	0.116369	0.014033	0.006332	0.021166	0.033577	0.002613	0.001817	0.005285	0.000712	0.000821
Apartments Mid Rise	0.543088	0.044216	0.209971	0.116369	0.014033	0.006332	0.021166	0.033577	0.002613	0.001817	0.005285	0.000712	0.000821
General Office Building	0.543088	0.044216	0.209971	0.116369	0.014033	0.006332	0.021166	0.033577	0.002613	0.001817	0.005285	0.000712	0.000821
High Turnover (Sit Down Restaurant)	0.543088	0.044216	0.209971	0.116369	0.014033	0.006332	0.021166	0.033577	0.002613	0.001817	0.005285	0.000712	0.000821
Hotel	0.543088	0.044216	0.209971	0.116369	0.014033	0.006332	0.021166	0.033577	0.002613	0.001817	0.005285	0.000712	0.000821
Quality Restaurant	0.543088	0.044216	0.209971	0.116369	0.014033	0.006332	0.021166	0.033577	0.002613	0.001817	0.005285	0.000712	0.000821
Regional Shopping Center	0.543088	0.044216	0.209971	0.116369	0.014033	0.006332	0.021166	0.033577	0.002613	0.001817	0.005285	0.000712	0.000821

5.0 Energy Detail

Historical Energy Use: N

5.1 Mitigation Measures Energy

Village South Specific Plan (Proposed) - Los Angeles-South Coast County, Winter

	ROG	NOx	CO	SO2	Fugitive PM10	Exhaust PM10	PM10 Total	Fugitive PM2.5	Exhaust PM2.5	PM2.5 Total	Bio- CO2	NBio- CO2	Total CO2	CH4	N2O	CO2e
Category	lb/day										lb/day					
NaturalGas Mitigated	0.7660	6.7462	4.2573	0.0418		0.5292	0.5292		0.5292	0.5292		8,355.983 2	8,355.983 2	0.1602	0.1532	8,405.638 7
NaturalGas Unmitigated	0.7660	6.7462	4.2573	0.0418		0.5292	0.5292		0.5292	0.5292		8,355.983 2	8,355.983 2	0.1602	0.1532	8,405.638 7

Village South Specific Plan (Proposed) - Los Angeles-South Coast County, Winter

5.2 Energy by Land Use - NaturalGas

Unmitigated

	NaturalGas Use	ROG	NOx	CO	SO2	Fugitive PM10	Exhaust PM10	PM10 Total	Fugitive PM2.5	Exhaust PM2.5	PM2.5 Total	Bio- CO2	NBio- CO2	Total CO2	CH4	N2O	CO2e
Land Use	kBTU/yr	lb/day										lb/day					
Apartments Low Rise	1119.16	0.0121	0.1031	0.0439	6.6000e-004		8.3400e-003	8.3400e-003		8.3400e-003	8.3400e-003		131.6662	131.6662	2.5200e-003	2.4100e-003	132.4486
Apartments Mid Rise	35784.3	0.3859	3.2978	1.4033	0.0211		0.2666	0.2666		0.2666	0.2666		4,209.9164	4,209.9164	0.0807	0.0772	4,234.9339
General Office Building	1283.42	0.0138	0.1258	0.1057	7.5000e-004		9.5600e-003	9.5600e-003		9.5600e-003	9.5600e-003		150.9911	150.9911	2.8900e-003	2.7700e-003	151.8884
High Turnover (Sit Down Restaurant)	22759.9	0.2455	2.2314	1.8743	0.0134		0.1696	0.1696		0.1696	0.1696		2,677.6342	2,677.6342	0.0513	0.0491	2,693.5460
Hotel	4769.72	0.0514	0.4676	0.3928	2.8100e-003		0.0355	0.0355		0.0355	0.0355		561.1436	561.1436	0.0108	0.0103	564.4782
Quality Restaurant	5057.75	0.0545	0.4959	0.4165	2.9800e-003		0.0377	0.0377		0.0377	0.0377		595.0298	595.0298	0.0114	0.0109	598.5658
Regional Shopping Center	251.616	2.7100e-003	0.0247	0.0207	1.5000e-004		1.8700e-003	1.8700e-003		1.8700e-003	1.8700e-003		29.6019	29.6019	5.7000e-004	5.4000e-004	29.7778
Total		0.7660	6.7463	4.2573	0.0418		0.5292	0.5292		0.5292	0.5292		8,355.9832	8,355.9832	0.1602	0.1532	8,405.6387

Village South Specific Plan (Proposed) - Los Angeles-South Coast County, Winter

5.2 Energy by Land Use - NaturalGas

Mitigated

	NaturalGas Use	ROG	NOx	CO	SO2	Fugitive PM10	Exhaust PM10	PM10 Total	Fugitive PM2.5	Exhaust PM2.5	PM2.5 Total	Bio- CO2	NBio- CO2	Total CO2	CH4	N2O	CO2e
Land Use	kBTU/yr	lb/day										lb/day					
Apartments Low Rise	1.11916	0.0121	0.1031	0.0439	6.6000e-004		8.3400e-003	8.3400e-003		8.3400e-003	8.3400e-003		131.6662	131.6662	2.5200e-003	2.4100e-003	132.4486
Apartments Mid Rise	35.7843	0.3859	3.2978	1.4033	0.0211		0.2666	0.2666		0.2666	0.2666		4,209.9164	4,209.9164	0.0807	0.0772	4,234.9339
General Office Building	1.28342	0.0138	0.1258	0.1057	7.5000e-004		9.5600e-003	9.5600e-003		9.5600e-003	9.5600e-003		150.9911	150.9911	2.8900e-003	2.7700e-003	151.8884
High Turnover (Sit Down Restaurant)	22.7599	0.2455	2.2314	1.8743	0.0134		0.1696	0.1696		0.1696	0.1696		2,677.6342	2,677.6342	0.0513	0.0491	2,693.5460
Hotel	4.76972	0.0514	0.4676	0.3928	2.8100e-003		0.0355	0.0355		0.0355	0.0355		561.1436	561.1436	0.0108	0.0103	564.4782
Quality Restaurant	5.05775	0.0545	0.4959	0.4165	2.9800e-003		0.0377	0.0377		0.0377	0.0377		595.0298	595.0298	0.0114	0.0109	598.5658
Regional Shopping Center	0.251616	2.7100e-003	0.0247	0.0207	1.5000e-004		1.8700e-003	1.8700e-003		1.8700e-003	1.8700e-003		29.6019	29.6019	5.7000e-004	5.4000e-004	29.7778
Total		0.7660	6.7463	4.2573	0.0418		0.5292	0.5292		0.5292	0.5292		8,355.9832	8,355.9832	0.1602	0.1532	8,405.6387

6.0 Area Detail

6.1 Mitigation Measures Area

Village South Specific Plan (Proposed) - Los Angeles-South Coast County, Winter

	ROG	NOx	CO	SO2	Fugitive PM10	Exhaust PM10	PM10 Total	Fugitive PM2.5	Exhaust PM2.5	PM2.5 Total	Bio- CO2	NBio- CO2	Total CO2	CH4	N2O	CO2e
Category	lb/day										lb/day					
Mitigated	30.5020	15.0496	88.4430	0.0944		1.5974	1.5974		1.5974	1.5974	0.0000	18,148.5950	18,148.5950	0.4874	0.3300	18,259.1192
Unmitigated	30.5020	15.0496	88.4430	0.0944		1.5974	1.5974		1.5974	1.5974	0.0000	18,148.5950	18,148.5950	0.4874	0.3300	18,259.1192

6.2 Area by SubCategory

Unmitigated

	ROG	NOx	CO	SO2	Fugitive PM10	Exhaust PM10	PM10 Total	Fugitive PM2.5	Exhaust PM2.5	PM2.5 Total	Bio- CO2	NBio- CO2	Total CO2	CH4	N2O	CO2e
SubCategory	lb/day										lb/day					
Architectural Coating	2.2670					0.0000	0.0000		0.0000	0.0000			0.0000			0.0000
Consumer Products	24.1085					0.0000	0.0000		0.0000	0.0000			0.0000			0.0000
Hearth	1.6500	14.1000	6.0000	0.0900		1.1400	1.1400		1.1400	1.1400	0.0000	18,000.0000	18,000.0000	0.3450	0.3300	18,106.9650
Landscaping	2.4766	0.9496	82.4430	4.3600e-003		0.4574	0.4574		0.4574	0.4574		148.5950	148.5950	0.1424		152.1542
Total	30.5020	15.0496	88.4430	0.0944		1.5974	1.5974		1.5974	1.5974	0.0000	18,148.5950	18,148.5950	0.4874	0.3300	18,259.1192

Village South Specific Plan (Proposed) - Los Angeles-South Coast County, Winter

6.2 Area by SubCategory

Mitigated

	ROG	NOx	CO	SO2	Fugitive PM10	Exhaust PM10	PM10 Total	Fugitive PM2.5	Exhaust PM2.5	PM2.5 Total	Bio- CO2	NBio- CO2	Total CO2	CH4	N2O	CO2e
SubCategory	lb/day										lb/day					
Architectural Coating	2.2670					0.0000	0.0000		0.0000	0.0000			0.0000			0.0000
Consumer Products	24.1085					0.0000	0.0000		0.0000	0.0000			0.0000			0.0000
Hearth	1.6500	14.1000	6.0000	0.0900		1.1400	1.1400		1.1400	1.1400	0.0000	18,000.0000	18,000.0000	0.3450	0.3300	18,106.9650
Landscaping	2.4766	0.9496	82.4430	4.3600e-003		0.4574	0.4574		0.4574	0.4574		148.5950	148.5950	0.1424		152.1542
Total	30.5020	15.0496	88.4430	0.0944		1.5974	1.5974		1.5974	1.5974	0.0000	18,148.5950	18,148.5950	0.4874	0.3300	18,259.1192

7.0 Water Detail

7.1 Mitigation Measures Water

8.0 Waste Detail

8.1 Mitigation Measures Waste

9.0 Operational Offroad

Equipment Type	Number	Hours/Day	Days/Year	Horse Power	Load Factor	Fuel Type
----------------	--------	-----------	-----------	-------------	-------------	-----------

10.0 Stationary Equipment

Village South Specific Plan (Proposed) - Los Angeles-South Coast County, Winter

Fire Pumps and Emergency Generators

Equipment Type	Number	Hours/Day	Hours/Year	Horse Power	Load Factor	Fuel Type
----------------	--------	-----------	------------	-------------	-------------	-----------

Boilers

Equipment Type	Number	Heat Input/Day	Heat Input/Year	Boiler Rating	Fuel Type
----------------	--------	----------------	-----------------	---------------	-----------

User Defined Equipment

Equipment Type	Number
----------------	--------

11.0 Vegetation

Attachment C

Local Hire Provision Net Change	
Without Local Hire Provision	
Total Construction GHG Emissions (MT CO ₂ e)	3,623
Amortized (MT CO ₂ e/year)	120.77
With Local Hire Provision	
Total Construction GHG Emissions (MT CO ₂ e)	3,024
Amortized (MT CO ₂ e/year)	100.80
<i>% Decrease in Construction-related GHG Emissions</i>	17%

EXHIBIT B



Paul Rosenfeld, Ph.D.

Principal Environmental Chemist

Chemical Fate and Transport & Air Dispersion Modeling

Risk Assessment & Remediation Specialist

Education

Ph.D. Soil Chemistry, University of Washington, 1999. Dissertation on volatile organic compound filtration.

M.S. Environmental Science, U.C. Berkeley, 1995. Thesis on organic waste economics.

B.A. Environmental Studies, U.C. Santa Barbara, 1991. Thesis on wastewater treatment.

Professional Experience

Dr. Rosenfeld has over 25 years' experience conducting environmental investigations and risk assessments for evaluating impacts to human health, property, and ecological receptors. His expertise focuses on the fate and transport of environmental contaminants, human health risk, exposure assessment, and ecological restoration. Dr. Rosenfeld has evaluated and modeled emissions from unconventional oil drilling operations, oil spills, landfills, boilers and incinerators, process stacks, storage tanks, confined animal feeding operations, and many other industrial and agricultural sources. His project experience ranges from monitoring and modeling of pollution sources to evaluating impacts of pollution on workers at industrial facilities and residents in surrounding communities.

Dr. Rosenfeld has investigated and designed remediation programs and risk assessments for contaminated sites containing lead, heavy metals, mold, bacteria, particulate matter, petroleum hydrocarbons, chlorinated solvents, pesticides, radioactive waste, dioxins and furans, semi- and volatile organic compounds, PCBs, PAHs, perchlorate, asbestos, per- and poly-fluoroalkyl substances (PFOA/PFOS), unusual polymers, fuel oxygenates (MTBE), among other pollutants. Dr. Rosenfeld also has experience evaluating greenhouse gas emissions from various projects and is an expert on the assessment of odors from industrial and agricultural sites, as well as the evaluation of odor nuisance impacts and technologies for abatement of odorous emissions. As a principal scientist at SWAPE, Dr. Rosenfeld directs air dispersion modeling and exposure assessments. He has served as an expert witness and testified about pollution sources causing nuisance and/or personal injury at dozens of sites and has testified as an expert witness on more than ten cases involving exposure to air contaminants from industrial sources.

Professional History:

Soil Water Air Protection Enterprise (SWAPE); 2003 to present; Principal and Founding Partner
UCLA School of Public Health; 2007 to 2011; Lecturer (Assistant Researcher)
UCLA School of Public Health; 2003 to 2006; Adjunct Professor
UCLA Environmental Science and Engineering Program; 2002-2004; Doctoral Intern Coordinator
UCLA Institute of the Environment, 2001-2002; Research Associate
Komex H₂O Science, 2001 to 2003; Senior Remediation Scientist
National Groundwater Association, 2002-2004; Lecturer
San Diego State University, 1999-2001; Adjunct Professor
Anteon Corp., San Diego, 2000-2001; Remediation Project Manager
Ogden (now Amec), San Diego, 2000-2000; Remediation Project Manager
Bechtel, San Diego, California, 1999 – 2000; Risk Assessor
King County, Seattle, 1996 – 1999; Scientist
James River Corp., Washington, 1995-96; Scientist
Big Creek Lumber, Davenport, California, 1995; Scientist
Plumas Corp., California and USFS, Tahoe 1993-1995; Scientist
Peace Corps and World Wildlife Fund, St. Kitts, West Indies, 1991-1993; Scientist

Publications:

Remy, L.L., Clay T., Byers, V., **Rosenfeld P. E.** (2019) Hospital, Health, and Community Burden After Oil Refinery Fires, Richmond, California 2007 and 2012. *Environmental Health*. 18:48

Simons, R.A., Seo, Y. **Rosenfeld, P.**, (2015) Modeling the Effect of Refinery Emission On Residential Property Value. *Journal of Real Estate Research*. 27(3):321-342

Chen, J. A, Zapata A. R., Sutherland A. J., Molmen, D.R., Chow, B. S., Wu, L. E., **Rosenfeld, P. E.**, Hesse, R. C., (2012) Sulfur Dioxide and Volatile Organic Compound Exposure To A Community In Texas City Texas Evaluated Using Aermol and Empirical Data. *American Journal of Environmental Science*, 8(6), 622-632.

Rosenfeld, P.E. & Feng, L. (2011). *The Risks of Hazardous Waste*. Amsterdam: Elsevier Publishing.

Cheremisinoff, N.P., & **Rosenfeld, P.E.** (2011). *Handbook of Pollution Prevention and Cleaner Production: Best Practices in the Agrochemical Industry*, Amsterdam: Elsevier Publishing.

Gonzalez, J., Feng, L., Sutherland, A., Waller, C., Sok, H., Hesse, R., **Rosenfeld, P.** (2010). PCBs and Dioxins/Furans in Attic Dust Collected Near Former PCB Production and Secondary Copper Facilities in Sauget, IL. *Procedia Environmental Sciences*. 113–125.

Feng, L., Wu, C., Tam, L., Sutherland, A.J., Clark, J.J., **Rosenfeld, P.E.** (2010). Dioxin and Furan Blood Lipid and Attic Dust Concentrations in Populations Living Near Four Wood Treatment Facilities in the United States. *Journal of Environmental Health*. 73(6), 34-46.

Cheremisinoff, N.P., & **Rosenfeld, P.E.** (2010). *Handbook of Pollution Prevention and Cleaner Production: Best Practices in the Wood and Paper Industries*. Amsterdam: Elsevier Publishing.

Cheremisinoff, N.P., & **Rosenfeld, P.E.** (2009). *Handbook of Pollution Prevention and Cleaner Production: Best Practices in the Petroleum Industry*. Amsterdam: Elsevier Publishing.

Wu, C., Tam, L., Clark, J., **Rosenfeld, P.** (2009). Dioxin and furan blood lipid concentrations in populations living near four wood treatment facilities in the United States. *WIT Transactions on Ecology and the Environment, Air Pollution*, 123 (17), 319-327.

Tam L. K., Wu C. D., Clark J. J. and **Rosenfeld, P.E.** (2008). A Statistical Analysis Of Attic Dust And Blood Lipid Concentrations Of Tetrachloro-p-Dibenzodioxin (TCDD) Toxicity Equivalency Quotients (TEQ) In Two Populations Near Wood Treatment Facilities. *Organohalogen Compounds*, 70, 002252-002255.

Tam L. K., Wu C. D., Clark J. J. and **Rosenfeld, P.E.** (2008). Methods For Collect Samples For Assessing Dioxins And Other Environmental Contaminants In Attic Dust: A Review. *Organohalogen Compounds*, 70, 000527-000530.

Hensley, A.R. A. Scott, J. J. J. Clark, **Rosenfeld, P.E.** (2007). Attic Dust and Human Blood Samples Collected near a Former Wood Treatment Facility. *Environmental Research*. 105, 194-197.

Rosenfeld, P.E., J. J. J. Clark, A. R. Hensley, M. Suffet. (2007). The Use of an Odor Wheel Classification for Evaluation of Human Health Risk Criteria for Compost Facilities. *Water Science & Technology* 55(5), 345-357.

Rosenfeld, P. E., M. Suffet. (2007). The Anatomy Of Odour Wheels For Odours Of Drinking Water, Wastewater, Compost And The Urban Environment. *Water Science & Technology* 55(5), 335-344.

Sullivan, P. J. Clark, J.J.J., Agardy, F. J., **Rosenfeld, P.E.** (2007). *Toxic Legacy, Synthetic Toxins in the Food, Water, and Air in American Cities*. Boston Massachusetts: Elsevier Publishing

Rosenfeld, P.E., and Suffet I.H. (2004). Control of Compost Odor Using High Carbon Wood Ash. *Water Science and Technology*. 49(9),171-178.

Rosenfeld P. E., J.J. Clark, I.H. (Mel) Suffet (2004). The Value of An Odor-Quality-Wheel Classification Scheme For The Urban Environment. *Water Environment Federation's Technical Exhibition and Conference (WEFTEC) 2004*. New Orleans, October 2-6, 2004.

Rosenfeld, P.E., and Suffet, I.H. (2004). Understanding Odorants Associated With Compost, Biomass Facilities, and the Land Application of Biosolids. *Water Science and Technology*. 49(9), 193-199.

Rosenfeld, P.E., and Suffet I.H. (2004). Control of Compost Odor Using High Carbon Wood Ash, *Water Science and Technology*, 49(9), 171-178.

Rosenfeld, P. E., Grey, M. A., Sellev, P. (2004). Measurement of Biosolids Odor and Odorant Emissions from Windrows, Static Pile and Biofilter. *Water Environment Research*. 76(4), 310-315.

Rosenfeld, P.E., Grey, M and Suffet, M. (2002). Compost Demonstration Project, Sacramento California Using High-Carbon Wood Ash to Control Odor at a Green Materials Composting Facility. *Integrated Waste Management Board Public Affairs Office, Publications Clearinghouse (MS-6)*, Sacramento, CA Publication #442-02-008.

Rosenfeld, P.E., and C.L. Henry. (2001). Characterization of odor emissions from three different biosolids. *Water Soil and Air Pollution*. 127(1-4), 173-191.

Rosenfeld, P.E., and Henry C. L., (2000). Wood ash control of odor emissions from biosolids application. *Journal of Environmental Quality*. 29, 1662-1668.

Rosenfeld, P.E., C.L. Henry and D. Bennett. (2001). Wastewater dewatering polymer affect on biosolids odor emissions and microbial activity. *Water Environment Research*. 73(4), 363-367.

Rosenfeld, P.E., and C.L. Henry. (2001). Activated Carbon and Wood Ash Sorption of Wastewater, Compost, and Biosolids Odorants. *Water Environment Research*, 73, 388-393.

Rosenfeld, P.E., and Henry C. L., (2001). High carbon wood ash effect on biosolids microbial activity and odor. *Water Environment Research*. 131(1-4), 247-262.

Chollack, T. and **P. Rosenfeld**. (1998). Compost Amendment Handbook For Landscaping. Prepared for and distributed by the City of Redmond, Washington State.

Rosenfeld, P. E. (1992). The Mount Liamuiga Crater Trail. *Heritage Magazine of St. Kitts*, 3(2).

Rosenfeld, P. E. (1993). High School Biogas Project to Prevent Deforestation On St. Kitts. *Biomass Users Network*, 7(1).

Rosenfeld, P. E. (1998). Characterization, Quantification, and Control of Odor Emissions From Biosolids Application To Forest Soil. Doctoral Thesis. University of Washington College of Forest Resources.

Rosenfeld, P. E. (1994). Potential Utilization of Small Diameter Trees on Sierra County Public Land. Masters thesis reprinted by the Sierra County Economic Council. Sierra County, California.

Rosenfeld, P. E. (1991). How to Build a Small Rural Anaerobic Digester & Uses Of Biogas In The First And Third World. Bachelors Thesis. University of California.

Presentations:

Rosenfeld, P.E., Sutherland, A; Hesse, R.; Zapata, A. (October 3-6, 2013). Air dispersion modeling of volatile organic emissions from multiple natural gas wells in Decatur, TX. *44th Western Regional Meeting, American Chemical Society*. Lecture conducted from Santa Clara, CA.

Sok, H.L.; Waller, C.C.; Feng, L.; Gonzalez, J.; Sutherland, A.J.; Wisdom-Stack, T.; Sahai, R.K.; Hesse, R.C.; **Rosenfeld, P.E.** (June 20-23, 2010). Atrazine: A Persistent Pesticide in Urban Drinking Water. *Urban Environmental Pollution*. Lecture conducted from Boston, MA.

Feng, L.; Gonzalez, J.; Sok, H.L.; Sutherland, A.J.; Waller, C.C.; Wisdom-Stack, T.; Sahai, R.K.; La, M.; Hesse, R.C.; **Rosenfeld, P.E.** (June 20-23, 2010). Bringing Environmental Justice to East St. Louis, Illinois. *Urban Environmental Pollution*. Lecture conducted from Boston, MA.

Rosenfeld, P.E. (April 19-23, 2009). Perfluorooctanoic Acid (PFOA) and Perfluorooctane Sulfonate (PFOS) Contamination in Drinking Water From the Use of Aqueous Film Forming Foams (AFFF) at Airports in the United States. *2009 Ground Water Summit and 2009 Ground Water Protection Council Spring Meeting*, Lecture conducted from Tuscon, AZ.

Rosenfeld, P.E. (April 19-23, 2009). Cost to Filter Atrazine Contamination from Drinking Water in the United States” Contamination in Drinking Water From the Use of Aqueous Film Forming Foams (AFFF) at Airports in the United States. *2009 Ground Water Summit and 2009 Ground Water Protection Council Spring Meeting*. Lecture conducted from Tuscon, AZ.

Wu, C., Tam, L., Clark, J., **Rosenfeld, P.** (20-22 July, 2009). Dioxin and furan blood lipid concentrations in populations living near four wood treatment facilities in the United States. Brebbia, C.A. and Popov, V., eds., *Air Pollution XVII: Proceedings of the Seventeenth International Conference on Modeling, Monitoring and Management of Air Pollution*. Lecture conducted from Tallinn, Estonia.

Rosenfeld, P. E. (October 15-18, 2007). Moss Point Community Exposure To Contaminants From A Releasing Facility. *The 23rd Annual International Conferences on Soils Sediment and Water*. Platform lecture conducted from University of Massachusetts, Amherst MA.

Rosenfeld, P. E. (October 15-18, 2007). The Repeated Trespass of Tritium-Contaminated Water Into A Surrounding Community Form Repeated Waste Spills From A Nuclear Power Plant. *The 23rd Annual International Conferences on Soils Sediment and Water*. Platform lecture conducted from University of Massachusetts, Amherst MA.

Rosenfeld, P. E. (October 15-18, 2007). Somerville Community Exposure To Contaminants From Wood Treatment Facility Emissions. The *23rd Annual International Conferences on Soils Sediment and Water*. Lecture conducted from University of Massachusetts, Amherst MA.

Rosenfeld P. E. (March 2007). Production, Chemical Properties, Toxicology, & Treatment Case Studies of 1,2,3-Trichloropropane (TCP). *The Association for Environmental Health and Sciences (AEHS) Annual Meeting*. Lecture conducted from San Diego, CA.

Rosenfeld P. E. (March 2007). Blood and Attic Sampling for Dioxin/Furan, PAH, and Metal Exposure in Florida, Alabama. *The AEHS Annual Meeting*. Lecture conducted from San Diego, CA.

Hensley A.R., Scott, A., **Rosenfeld P.E.**, Clark, J.J.J. (August 21 – 25, 2006). Dioxin Containing Attic Dust And Human Blood Samples Collected Near A Former Wood Treatment Facility. *The 26th International Symposium on Halogenated Persistent Organic Pollutants – DIOXIN2006*. Lecture conducted from Radisson SAS Scandinavia Hotel in Oslo Norway.

Hensley A.R., Scott, A., **Rosenfeld P.E.**, Clark, J.J.J. (November 4-8, 2006). Dioxin Containing Attic Dust And Human Blood Samples Collected Near A Former Wood Treatment Facility. *APHA 134 Annual Meeting & Exposition*. Lecture conducted from Boston Massachusetts.

Paul Rosenfeld Ph.D. (October 24-25, 2005). Fate, Transport and Persistence of PFOA and Related Chemicals. Mealey's C8/PFOA. *Science, Risk & Litigation Conference*. Lecture conducted from The Rittenhouse Hotel, Philadelphia, PA.

Paul Rosenfeld Ph.D. (September 19, 2005). Brominated Flame Retardants in Groundwater: Pathways to Human Ingestion, *Toxicology and Remediation PEMA Emerging Contaminant Conference*. Lecture conducted from Hilton Hotel, Irvine California.

Paul Rosenfeld Ph.D. (September 19, 2005). Fate, Transport, Toxicity, And Persistence of 1,2,3-TCP. *PEMA Emerging Contaminant Conference*. Lecture conducted from Hilton Hotel in Irvine, California.

Paul Rosenfeld Ph.D. (September 26-27, 2005). Fate, Transport and Persistence of PDBEs. *Mealey's Groundwater Conference*. Lecture conducted from Ritz Carlton Hotel, Marina Del Ray, California.

Paul Rosenfeld Ph.D. (June 7-8, 2005). Fate, Transport and Persistence of PFOA and Related Chemicals. *International Society of Environmental Forensics: Focus On Emerging Contaminants*. Lecture conducted from Sheraton Oceanfront Hotel, Virginia Beach, Virginia.

Paul Rosenfeld Ph.D. (July 21-22, 2005). Fate Transport, Persistence and Toxicology of PFOA and Related Perfluorochemicals. *2005 National Groundwater Association Ground Water And Environmental Law Conference*. Lecture conducted from Wyndham Baltimore Inner Harbor, Baltimore Maryland.

Paul Rosenfeld Ph.D. (July 21-22, 2005). Brominated Flame Retardants in Groundwater: Pathways to Human Ingestion, Toxicology and Remediation. *2005 National Groundwater Association Ground Water and Environmental Law Conference*. Lecture conducted from Wyndham Baltimore Inner Harbor, Baltimore Maryland.

Paul Rosenfeld, Ph.D. and James Clark Ph.D. and Rob Hesse R.G. (May 5-6, 2004). Tert-butyl Alcohol Liability and Toxicology, A National Problem and Unquantified Liability. *National Groundwater Association. Environmental Law Conference*. Lecture conducted from Congress Plaza Hotel, Chicago Illinois.

Paul Rosenfeld, Ph.D. (March 2004). Perchlorate Toxicology. *Meeting of the American Groundwater Trust*. Lecture conducted from Phoenix Arizona.

Hagemann, M.F., **Paul Rosenfeld, Ph.D.** and Rob Hesse (2004). Perchlorate Contamination of the Colorado River. *Meeting of tribal representatives*. Lecture conducted from Parker, AZ.

Paul Rosenfeld, Ph.D. (April 7, 2004). A National Damage Assessment Model For PCE and Dry Cleaners. *Drycleaner Symposium. California Ground Water Association*. Lecture conducted from Radison Hotel, Sacramento, California.

Rosenfeld, P. E., Grey, M., (June 2003) Two stage biofilter for biosolids composting odor control. *Seventh International In Situ And On Site Bioremediation Symposium Battelle Conference* Orlando, FL.

Paul Rosenfeld, Ph.D. and James Clark Ph.D. (February 20-21, 2003) Understanding Historical Use, Chemical Properties, Toxicity and Regulatory Guidance of 1,4 Dioxane. *National Groundwater Association. Southwest Focus Conference. Water Supply and Emerging Contaminants..* Lecture conducted from Hyatt Regency Phoenix Arizona.

Paul Rosenfeld, Ph.D. (February 6-7, 2003). Underground Storage Tank Litigation and Remediation. *California CUPA Forum*. Lecture conducted from Marriott Hotel, Anaheim California.

Paul Rosenfeld, Ph.D. (October 23, 2002) Underground Storage Tank Litigation and Remediation. *EPA Underground Storage Tank Roundtable*. Lecture conducted from Sacramento California.

Rosenfeld, P.E. and Suffet, M. (October 7- 10, 2002). Understanding Odor from Compost, *Wastewater and Industrial Processes. Sixth Annual Symposium On Off Flavors in the Aquatic Environment. International Water Association*. Lecture conducted from Barcelona Spain.

Rosenfeld, P.E. and Suffet, M. (October 7- 10, 2002). Using High Carbon Wood Ash to Control Compost Odor. *Sixth Annual Symposium On Off Flavors in the Aquatic Environment. International Water Association*. Lecture conducted from Barcelona Spain.

Rosenfeld, P.E. and Grey, M. A. (September 22-24, 2002). Biocycle Composting For Coastal Sage Restoration. *Northwest Biosolids Management Association*. Lecture conducted from Vancouver Washington..

Rosenfeld, P.E. and Grey, M. A. (November 11-14, 2002). Using High-Carbon Wood Ash to Control Odor at a Green Materials Composting Facility. *Soil Science Society Annual Conference*. Lecture conducted from Indianapolis, Maryland.

Rosenfeld, P.E. (September 16, 2000). Two stage biofilter for biosolids composting odor control. *Water Environment Federation*. Lecture conducted from Anaheim California.

Rosenfeld, P.E. (October 16, 2000). Wood ash and biofilter control of compost odor. *Biofest*. Lecture conducted from Ocean Shores, California.

Rosenfeld, P.E. (2000). Bioremediation Using Organic Soil Amendments. *California Resource Recovery Association*. Lecture conducted from Sacramento California.

Rosenfeld, P.E., C.L. Henry, R. Harrison. (1998). Oat and Grass Seed Germination and Nitrogen and Sulfur Emissions Following Biosolids Incorporation With High-Carbon Wood-Ash. *Water Environment Federation 12th Annual Residuals and Biosolids Management Conference Proceedings*. Lecture conducted from Bellevue Washington.

Rosenfeld, P.E., and C.L. Henry. (1999). An evaluation of ash incorporation with biosolids for odor reduction. *Soil Science Society of America*. Lecture conducted from Salt Lake City Utah.

Rosenfeld, P.E., C.L. Henry, R. Harrison. (1998). Comparison of Microbial Activity and Odor Emissions from Three Different Biosolids Applied to Forest Soil. *Brown and Caldwell*. Lecture conducted from Seattle Washington.

Rosenfeld, P.E., C.L. Henry. (1998). Characterization, Quantification, and Control of Odor Emissions from Biosolids Application To Forest Soil. *Biofest*. Lecture conducted from Lake Chelan, Washington.

Rosenfeld, P.E., C.L. Henry, R. Harrison. (1998). Oat and Grass Seed Germination and Nitrogen and Sulfur Emissions Following Biosolids Incorporation With High-Carbon Wood-Ash. Water Environment Federation 12th Annual Residuals and Biosolids Management Conference Proceedings. Lecture conducted from Bellevue Washington.

Rosenfeld, P.E., C.L. Henry, R. B. Harrison, and R. Dills. (1997). Comparison of Odor Emissions From Three Different Biosolids Applied to Forest Soil. *Soil Science Society of America*. Lecture conducted from Anaheim California.

Teaching Experience:

UCLA Department of Environmental Health (Summer 2003 through 2010) Taught Environmental Health Science 100 to students, including undergrad, medical doctors, public health professionals and nurses. Course focused on the health effects of environmental contaminants.

National Ground Water Association, Successful Remediation Technologies. Custom Course in Sante Fe, New Mexico. May 21, 2002. Focused on fate and transport of fuel contaminants associated with underground storage tanks.

National Ground Water Association; Successful Remediation Technologies Course in Chicago Illinois. April 1, 2002. Focused on fate and transport of contaminants associated with Superfund and RCRA sites.

California Integrated Waste Management Board, April and May, 2001. Alternative Landfill Caps Seminar in San Diego, Ventura, and San Francisco. Focused on both prescriptive and innovative landfill cover design.

UCLA Department of Environmental Engineering, February 5, 2002. Seminar on Successful Remediation Technologies focusing on Groundwater Remediation.

University Of Washington, Soil Science Program, Teaching Assistant for several courses including: Soil Chemistry, Organic Soil Amendments, and Soil Stability.

U.C. Berkeley, Environmental Science Program Teaching Assistant for Environmental Science 10.

Academic Grants Awarded:

California Integrated Waste Management Board. \$41,000 grant awarded to UCLA Institute of the Environment. Goal: To investigate effect of high carbon wood ash on volatile organic emissions from compost. 2001.

Synagro Technologies, Corona California: \$10,000 grant awarded to San Diego State University. Goal: investigate effect of biosolids for restoration and remediation of degraded coastal sage soils. 2000.

King County, Department of Research and Technology, Washington State. \$100,000 grant awarded to University of Washington: Goal: To investigate odor emissions from biosolids application and the effect of polymers and ash on VOC emissions. 1998.

Northwest Biosolids Management Association, Washington State. \$20,000 grant awarded to investigate effect of polymers and ash on VOC emissions from biosolids. 1997.

James River Corporation, Oregon: \$10,000 grant was awarded to investigate the success of genetically engineered Poplar trees with resistance to round-up. 1996.

United State Forest Service, Tahoe National Forest: \$15,000 grant was awarded to investigating fire ecology of the Tahoe National Forest. 1995.

Kellogg Foundation, Washington D.C. \$500 grant was awarded to construct a large anaerobic digester on St. Kitts in West Indies. 1993

Deposition and/or Trial Testimony:

- In the United States District Court For The District of New Jersey
Duarte et al, *Plaintiffs*, vs. United States Metals Refining Company et. al. *Defendant*.
Case No.: 2:17-cv-01624-ES-SCM
Rosenfeld Deposition. 6-7-2019
- In the United States District Court of Southern District of Texas Galveston Division
M/T Carla Maersk, *Plaintiffs*, vs. Conti 168., Schiffahrts-GMBH & Co. Bulker KG MS “Conti Perdido”
Defendant.
Case No.: 3:15-CV-00106 consolidated with 3:15-CV-00237
Rosenfeld Deposition. 5-9-2019
- In The Superior Court of the State of California In And For The County Of Los Angeles – Santa Monica
Carole-Taddeo-Bates et al., vs. Ifran Khan et al., Defendants
Case No.: No. BC615636
Rosenfeld Deposition, 1-26-2019
- In The Superior Court of the State of California In And For The County Of Los Angeles – Santa Monica
The San Gabriel Valley Council of Governments et al. vs El Adobe Apts. Inc. et al., Defendants
Case No.: No. BC646857
Rosenfeld Deposition, 10-6-2018; Trial 3-7-19
- In United States District Court For The District of Colorado
Bells et al. Plaintiff vs. The 3M Company et al., Defendants
Case: No 1:16-cv-02531-RBJ
Rosenfeld Deposition, 3-15-2018 and 4-3-2018
- In The District Court Of Regan County, Texas, 112th Judicial District
Phillip Bales et al., Plaintiff vs. Dow Agrosiences, LLC, et al., Defendants
Cause No 1923
Rosenfeld Deposition, 11-17-2017
- In The Superior Court of the State of California In And For The County Of Contra Costa
Simons et al., Plaintiffs vs. Chevron Corporation, et al., Defendants
Cause No C12-01481
Rosenfeld Deposition, 11-20-2017
- In The Circuit Court Of The Twentieth Judicial Circuit, St Clair County, Illinois
Martha Custer et al., Plaintiff vs. Cerro Flow Products, Inc., Defendants
Case No.: No. 0i9-L-2295
Rosenfeld Deposition, 8-23-2017
- In The Superior Court of the State of California, For The County of Los Angeles
Warrn Gilbert and Penny Gilber, Plaintiff vs. BMW of North America LLC
Case No.: LC102019 (c/w BC582154)
Rosenfeld Deposition, 8-16-2017, Trail 8-28-2018
- In the Northern District Court of Mississippi, Greenville Division
Brenda J. Cooper, et al., *Plaintiffs*, vs. Meritor Inc., et al., *Defendants*
Case Number: 4:16-cv-52-DMB-JVM
Rosenfeld Deposition: July 2017

In The Superior Court of the State of Washington, County of Snohomish
Michael Davis and Julie Davis et al., Plaintiff vs. Cedar Grove Composting Inc., Defendants
Case No.: No. 13-2-03987-5
Rosenfeld Deposition, February 2017
Trial, March 2017

In The Superior Court of the State of California, County of Alameda
Charles Spain., Plaintiff vs. Thermo Fisher Scientific, et al., Defendants
Case No.: RG14711115
Rosenfeld Deposition, September 2015

In The Iowa District Court In And For Poweshiek County
Russell D. Winburn, et al., Plaintiffs vs. Doug Hoksbergen, et al., Defendants
Case No.: LALA002187
Rosenfeld Deposition, August 2015

In The Iowa District Court For Wapello County
Jerry Dovico, et al., Plaintiffs vs. Valley View Sine LLC, et al., Defendants
Law No.: LALA105144 - Division A
Rosenfeld Deposition, August 2015

In The Iowa District Court For Wapello County
Doug Pauls, et al., et al., Plaintiffs vs. Richard Warren, et al., Defendants
Law No.: LALA105144 - Division A
Rosenfeld Deposition, August 2015

In The Circuit Court of Ohio County, West Virginia
Robert Andrews, et al. v. Antero, et al.
Civil Action NO. 14-C-30000
Rosenfeld Deposition, June 2015

In The Third Judicial District County of Dona Ana, New Mexico
Betty Gonzalez, et al. Plaintiffs vs. Del Oro Dairy, Del Oro Real Estate LLC, Jerry Settles and Deward
DeRuyter, Defendants
Rosenfeld Deposition: July 2015

In The Iowa District Court For Muscatine County
Laurie Freeman et. al. Plaintiffs vs. Grain Processing Corporation, Defendant
Case No 4980
Rosenfeld Deposition: May 2015

In the Circuit Court of the 17th Judicial Circuit, in and For Broward County, Florida
Walter Hinton, et. al. Plaintiff, vs. City of Fort Lauderdale, Florida, a Municipality, Defendant.
Case Number CACE07030358 (26)
Rosenfeld Deposition: December 2014

In the United States District Court Western District of Oklahoma
Tommy McCarty, et al., Plaintiffs, v. Oklahoma City Landfill, LLC d/b/a Southeast Oklahoma City
Landfill, et al. Defendants.
Case No. 5:12-cv-01152-C
Rosenfeld Deposition: July 2014

In the County Court of Dallas County Texas
Lisa Parr et al, *Plaintiff*, vs. Aruba et al, *Defendant*.
Case Number cc-11-01650-E
Rosenfeld Deposition: March and September 2013
Rosenfeld Trial: April 2014

In the Court of Common Pleas of Tuscarawas County Ohio
John Michael Abicht, et al., *Plaintiffs*, vs. Republic Services, Inc., et al., *Defendants*
Case Number: 2008 CT 10 0741 (Cons. w/ 2009 CV 10 0987)
Rosenfeld Deposition: October 2012

In the United States District Court of Southern District of Texas Galveston Division
Kyle Cannon, Eugene Donovan, Genaro Ramirez, Carol Sassler, and Harvey Walton, each Individually and on behalf of those similarly situated, *Plaintiffs*, vs. BP Products North America, Inc., *Defendant*.
Case 3:10-cv-00622
Rosenfeld Deposition: February 2012
Rosenfeld Trial: April 2013

In the Circuit Court of Baltimore County Maryland
Philip E. Cvach, II et al., *Plaintiffs* vs. Two Farms, Inc. d/b/a Royal Farms, Defendants
Case Number: 03-C-12-012487 OT
Rosenfeld Deposition: September 2013

EXHIBIT C



1640 5th St., Suite 204 Santa
Santa Monica, California 90401
Tel: (949) 887-9013
Email: mhagemann@swape.com

Matthew F. Hagemann, P.G., C.Hg., QSD, QSP

**Geologic and Hydrogeologic Characterization
Industrial Stormwater Compliance
Investigation and Remediation Strategies
Litigation Support and Testifying Expert
CEQA Review**

Education:

M.S. Degree, Geology, California State University Los Angeles, Los Angeles, CA, 1984.

B.A. Degree, Geology, Humboldt State University, Arcata, CA, 1982.

Professional Certifications:

California Professional Geologist

California Certified Hydrogeologist

Qualified SWPPP Developer and Practitioner

Professional Experience:

Matt has 25 years of experience in environmental policy, assessment and remediation. He spent nine years with the U.S. EPA in the RCRA and Superfund programs and served as EPA's Senior Science Policy Advisor in the Western Regional Office where he identified emerging threats to groundwater from perchlorate and MTBE. While with EPA, Matt also served as a Senior Hydrogeologist in the oversight of the assessment of seven major military facilities undergoing base closure. He led numerous enforcement actions under provisions of the Resource Conservation and Recovery Act (RCRA) while also working with permit holders to improve hydrogeologic characterization and water quality monitoring.

Matt has worked closely with U.S. EPA legal counsel and the technical staff of several states in the application and enforcement of RCRA, Safe Drinking Water Act and Clean Water Act regulations. Matt has trained the technical staff in the States of California, Hawaii, Nevada, Arizona and the Territory of Guam in the conduct of investigations, groundwater fundamentals, and sampling techniques.

Positions Matt has held include:

- Founding Partner, Soil/Water/Air Protection Enterprise (SWAPE) (2003 – present);
- Geology Instructor, Golden West College, 2010 – 2014;
- Senior Environmental Analyst, Komex H2O Science, Inc. (2000 -- 2003);

- Executive Director, Orange Coast Watch (2001 – 2004);
- Senior Science Policy Advisor and Hydrogeologist, U.S. Environmental Protection Agency (1989–1998);
- Hydrogeologist, National Park Service, Water Resources Division (1998 – 2000);
- Adjunct Faculty Member, San Francisco State University, Department of Geosciences (1993 – 1998);
- Instructor, College of Marin, Department of Science (1990 – 1995);
- Geologist, U.S. Forest Service (1986 – 1998); and
- Geologist, Dames & Moore (1984 – 1986).

Senior Regulatory and Litigation Support Analyst:

With SWAPE, Matt’s responsibilities have included:

- Lead analyst and testifying expert in the review of over 100 environmental impact reports since 2003 under CEQA that identify significant issues with regard to hazardous waste, water resources, water quality, air quality, Valley Fever, greenhouse gas emissions, and geologic hazards. Make recommendations for additional mitigation measures to lead agencies at the local and county level to include additional characterization of health risks and implementation of protective measures to reduce worker exposure to hazards from toxins and Valley Fever.
- Stormwater analysis, sampling and best management practice evaluation at industrial facilities.
- Manager of a project to provide technical assistance to a community adjacent to a former Naval shipyard under a grant from the U.S. EPA.
- Technical assistance and litigation support for vapor intrusion concerns.
- Lead analyst and testifying expert in the review of environmental issues in license applications for large solar power plants before the California Energy Commission.
- Manager of a project to evaluate numerous formerly used military sites in the western U.S.
- Manager of a comprehensive evaluation of potential sources of perchlorate contamination in Southern California drinking water wells.
- Manager and designated expert for litigation support under provisions of Proposition 65 in the review of releases of gasoline to sources drinking water at major refineries and hundreds of gas stations throughout California.
- Expert witness on two cases involving MTBE litigation.
- Expert witness and litigation support on the impact of air toxins and hazards at a school.
- Expert witness in litigation at a former plywood plant.

With Komex H2O Science Inc., Matt’s duties included the following:

- Senior author of a report on the extent of perchlorate contamination that was used in testimony by the former U.S. EPA Administrator and General Counsel.
- Senior researcher in the development of a comprehensive, electronically interactive chronology of MTBE use, research, and regulation.
- Senior researcher in the development of a comprehensive, electronically interactive chronology of perchlorate use, research, and regulation.
- Senior researcher in a study that estimates nationwide costs for MTBE remediation and drinking water treatment, results of which were published in newspapers nationwide and in testimony against provisions of an energy bill that would limit liability for oil companies.
- Research to support litigation to restore drinking water supplies that have been contaminated by MTBE in California and New York.

- Expert witness testimony in a case of oil production-related contamination in Mississippi.
- Lead author for a multi-volume remedial investigation report for an operating school in Los Angeles that met strict regulatory requirements and rigorous deadlines.

- Development of strategic approaches for cleanup of contaminated sites in consultation with clients and regulators.

Executive Director:

As Executive Director with Orange Coast Watch, Matt led efforts to restore water quality at Orange County beaches from multiple sources of contamination including urban runoff and the discharge of wastewater. In reporting to a Board of Directors that included representatives from leading Orange County universities and businesses, Matt prepared issue papers in the areas of treatment and disinfection of wastewater and control of the discharge of grease to sewer systems. Matt actively participated in the development of countywide water quality permits for the control of urban runoff and permits for the discharge of wastewater. Matt worked with other nonprofits to protect and restore water quality, including Surfrider, Natural Resources Defense Council and Orange County CoastKeeper as well as with business institutions including the Orange County Business Council.

Hydrogeology:

As a Senior Hydrogeologist with the U.S. Environmental Protection Agency, Matt led investigations to characterize and cleanup closing military bases, including Mare Island Naval Shipyard, Hunters Point Naval Shipyard, Treasure Island Naval Station, Alameda Naval Station, Moffett Field, Mather Army Airfield, and Sacramento Army Depot. Specific activities were as follows:

- Led efforts to model groundwater flow and contaminant transport, ensured adequacy of monitoring networks, and assessed cleanup alternatives for contaminated sediment, soil, and groundwater.
- Initiated a regional program for evaluation of groundwater sampling practices and laboratory analysis at military bases.
- Identified emerging issues, wrote technical guidance, and assisted in policy and regulation development through work on four national U.S. EPA workgroups, including the Superfund Groundwater Technical Forum and the Federal Facilities Forum.

At the request of the State of Hawaii, Matt developed a methodology to determine the vulnerability of groundwater to contamination on the islands of Maui and Oahu. He used analytical models and a GIS to show zones of vulnerability, and the results were adopted and published by the State of Hawaii and County of Maui.

As a hydrogeologist with the EPA Groundwater Protection Section, Matt worked with provisions of the Safe Drinking Water Act and NEPA to prevent drinking water contamination. Specific activities included the following:

- Received an EPA Bronze Medal for his contribution to the development of national guidance for the protection of drinking water.
- Managed the Sole Source Aquifer Program and protected the drinking water of two communities through designation under the Safe Drinking Water Act. He prepared geologic reports, conducted public hearings, and responded to public comments from residents who were very concerned about the impact of designation.

- Reviewed a number of Environmental Impact Statements for planned major developments, including large hazardous and solid waste disposal facilities, mine reclamation, and water transfer.

Matt served as a hydrogeologist with the RCRA Hazardous Waste program. Duties were as follows:

- Supervised the hydrogeologic investigation of hazardous waste sites to determine compliance with Subtitle C requirements.
- Reviewed and wrote "part B" permits for the disposal of hazardous waste.
- Conducted RCRA Corrective Action investigations of waste sites and led inspections that formed the basis for significant enforcement actions that were developed in close coordination with U.S. EPA legal counsel.
- Wrote contract specifications and supervised contractor's investigations of waste sites.

With the National Park Service, Matt directed service-wide investigations of contaminant sources to prevent degradation of water quality, including the following tasks:

- Applied pertinent laws and regulations including CERCLA, RCRA, NEPA, NRDA, and the Clean Water Act to control military, mining, and landfill contaminants.
- Conducted watershed-scale investigations of contaminants at parks, including Yellowstone and Olympic National Park.
- Identified high-levels of perchlorate in soil adjacent to a national park in New Mexico and advised park superintendent on appropriate response actions under CERCLA.
- Served as a Park Service representative on the Interagency Perchlorate Steering Committee, a national workgroup.
- Developed a program to conduct environmental compliance audits of all National Parks while serving on a national workgroup.
- Co-authored two papers on the potential for water contamination from the operation of personal watercraft and snowmobiles, these papers serving as the basis for the development of nation-wide policy on the use of these vehicles in National Parks.
- Contributed to the Federal Multi-Agency Source Water Agreement under the Clean Water Action Plan.

Policy:

Served senior management as the Senior Science Policy Advisor with the U.S. Environmental Protection Agency, Region 9. Activities included the following:

- Advised the Regional Administrator and senior management on emerging issues such as the potential for the gasoline additive MTBE and ammonium perchlorate to contaminate drinking water supplies.
- Shaped EPA's national response to these threats by serving on workgroups and by contributing to guidance, including the Office of Research and Development publication, *Oxygenates in Water: Critical Information and Research Needs*.
- Improved the technical training of EPA's scientific and engineering staff.
- Earned an EPA Bronze Medal for representing the region's 300 scientists and engineers in negotiations with the Administrator and senior management to better integrate scientific principles into the policy-making process.
- Established national protocol for the peer review of scientific documents.

Geology:

With the U.S. Forest Service, Matt led investigations to determine hillslope stability of areas proposed for timber harvest in the central Oregon Coast Range. Specific activities were as follows:

- Mapped geology in the field, and used aerial photographic interpretation and mathematical models to determine slope stability.
- Coordinated his research with community members who were concerned with natural resource protection.
- Characterized the geology of an aquifer that serves as the sole source of drinking water for the city of Medford, Oregon.

As a consultant with Dames and Moore, Matt led geologic investigations of two contaminated sites (later listed on the Superfund NPL) in the Portland, Oregon, area and a large hazardous waste site in eastern Oregon. Duties included the following:

- Supervised year-long effort for soil and groundwater sampling.
- Conducted aquifer tests.
- Investigated active faults beneath sites proposed for hazardous waste disposal.

Teaching:

From 1990 to 1998, Matt taught at least one course per semester at the community college and university levels:

- At San Francisco State University, held an adjunct faculty position and taught courses in environmental geology, oceanography (lab and lecture), hydrogeology, and groundwater contamination.
- Served as a committee member for graduate and undergraduate students.
- Taught courses in environmental geology and oceanography at the College of Marin.

Matt taught physical geology (lecture and lab and introductory geology at Golden West College in Huntington Beach, California from 2010 to 2014.

Invited Testimony, Reports, Papers and Presentations:

Hagemann, M.F., 2008. Disclosure of Hazardous Waste Issues under CEQA. Presentation to the Public Environmental Law Conference, Eugene, Oregon.

Hagemann, M.F., 2008. Disclosure of Hazardous Waste Issues under CEQA. Invited presentation to U.S. EPA Region 9, San Francisco, California.

Hagemann, M.F., 2005. Use of Electronic Databases in Environmental Regulation, Policy Making and Public Participation. Brownfields 2005, Denver, Colorado.

Hagemann, M.F., 2004. Perchlorate Contamination of the Colorado River and Impacts to Drinking Water in Nevada and the Southwestern U.S. Presentation to a meeting of the American Groundwater Trust, Las Vegas, NV (served on conference organizing committee).

Hagemann, M.F., 2004. Invited testimony to a California Senate committee hearing on air toxins at schools in Southern California, Los Angeles.

Brown, A., Farrow, J., Gray, A. and **Hagemann, M.**, 2004. An Estimate of Costs to Address MTBE Releases from Underground Storage Tanks and the Resulting Impact to Drinking Water Wells. Presentation to the Ground Water and Environmental Law Conference, National Groundwater Association.

Hagemann, M.F., 2004. Perchlorate Contamination of the Colorado River and Impacts to Drinking Water in Arizona and the Southwestern U.S. Presentation to a meeting of the American Groundwater Trust, Phoenix, AZ (served on conference organizing committee).

Hagemann, M.F., 2003. Perchlorate Contamination of the Colorado River and Impacts to Drinking Water in the Southwestern U.S. Invited presentation to a special committee meeting of the National Academy of Sciences, Irvine, CA.

Hagemann, M.F., 2003. Perchlorate Contamination of the Colorado River. Invited presentation to a tribal EPA meeting, Pechanga, CA.

Hagemann, M.F., 2003. Perchlorate Contamination of the Colorado River. Invited presentation to a meeting of tribal representatives, Parker, AZ.

Hagemann, M.F., 2003. Impact of Perchlorate on the Colorado River and Associated Drinking Water Supplies. Invited presentation to the Inter-Tribal Meeting, Torres Martinez Tribe.

Hagemann, M.F., 2003. The Emergence of Perchlorate as a Widespread Drinking Water Contaminant. Invited presentation to the U.S. EPA Region 9.

Hagemann, M.F., 2003. A Deductive Approach to the Assessment of Perchlorate Contamination. Invited presentation to the California Assembly Natural Resources Committee.

Hagemann, M.F., 2003. Perchlorate: A Cold War Legacy in Drinking Water. Presentation to a meeting of the National Groundwater Association.

Hagemann, M.F., 2002. From Tank to Tap: A Chronology of MTBE in Groundwater. Presentation to a meeting of the National Groundwater Association.

Hagemann, M.F., 2002. A Chronology of MTBE in Groundwater and an Estimate of Costs to Address Impacts to Groundwater. Presentation to the annual meeting of the Society of Environmental Journalists.

Hagemann, M.F., 2002. An Estimate of the Cost to Address MTBE Contamination in Groundwater (and Who Will Pay). Presentation to a meeting of the National Groundwater Association.

Hagemann, M.F., 2002. An Estimate of Costs to Address MTBE Releases from Underground Storage Tanks and the Resulting Impact to Drinking Water Wells. Presentation to a meeting of the U.S. EPA and State Underground Storage Tank Program managers.

Hagemann, M.F., 2001. From Tank to Tap: A Chronology of MTBE in Groundwater. Unpublished report.

Hagemann, M.F., 2001. Estimated Cleanup Cost for MTBE in Groundwater Used as Drinking Water. Unpublished report.

Hagemann, M.F., 2001. Estimated Costs to Address MTBE Releases from Leaking Underground Storage Tanks. Unpublished report.

Hagemann, M.F., and VanMouwerik, M., 1999. Potential Water Quality Concerns Related to Snowmobile Usage. Water Resources Division, National Park Service, Technical Report.

VanMouwerik, M. and **Hagemann, M.F.** 1999, Water Quality Concerns Related to Personal Watercraft Usage. Water Resources Division, National Park Service, Technical Report.

Hagemann, M.F., 1999, Is Dilution the Solution to Pollution in National Parks? The George Wright Society Biannual Meeting, Asheville, North Carolina.

Hagemann, M.F., 1997, The Potential for MTBE to Contaminate Groundwater. U.S. EPA Superfund Groundwater Technical Forum Annual Meeting, Las Vegas, Nevada.

Hagemann, M.F., and Gill, M., 1996, Impediments to Intrinsic Remediation, Moffett Field Naval Air Station, Conference on Intrinsic Remediation of Chlorinated Hydrocarbons, Salt Lake City.

Hagemann, M.F., Fukunaga, G.L., 1996, The Vulnerability of Groundwater to Anthropogenic Contaminants on the Island of Maui, Hawaii. Hawaii Water Works Association Annual Meeting, Maui, October 1996.

Hagemann, M. F., Fukanaga, G. L., 1996, Ranking Groundwater Vulnerability in Central Oahu, Hawaii. Proceedings, Geographic Information Systems in Environmental Resources Management, Air and Waste Management Association Publication VIP-61.

Hagemann, M.F., 1994. Groundwater Characterization and Cleanup at Closing Military Bases in California. Proceedings, California Groundwater Resources Association Meeting.

Hagemann, M.F. and Sabol, M.A., 1993. Role of the U.S. EPA in the High Plains States Groundwater Recharge Demonstration Program. Proceedings, Sixth Biennial Symposium on the Artificial Recharge of Groundwater.

Hagemann, M.F., 1993. U.S. EPA Policy on the Technical Impracticability of the Cleanup of DNAPL-contaminated Groundwater. California Groundwater Resources Association Meeting.

Hagemann, M.F., 1992. Dense Nonaqueous Phase Liquid Contamination of Groundwater: An Ounce of Prevention... Proceedings, Association of Engineering Geologists Annual Meeting, v. 35.

Other Experience:

Selected as subject matter expert for the California Professional Geologist licensing examination, 2009-2011.



T 510.836.4200
F 510.836.4205

1939 Harrison Street, Ste. 150
Oakland, CA 94612

www.lozeaudrury.com
Amalia@lozeaudrury.com

February 7, 2023

Via Email

Stephanie Escobar, Planning Assistant
City of Los Angeles
200 North Spring St, Rm. 763
Los Angeles, CA 90012
Stephanie.escobar@lacity.org

**Re: Comment on Categorical Exemption, 1200 N. Vine Street Project
(CPC-2022-7074-CU-DB-SPR-HCA; ENV-2022-7048-CE)
Hearing Officer Hearing; February 7, 2023**

Dear Ms. Escobar:

I am writing on behalf of Supporters Alliance for Environmental Responsibility (“SAFER”) regarding the proposed Class 32 In-fill Development Categorical Exemption (“Exemption”) for the 1200 N. Vine Street Project (CPC-2022-7074-CU-DB-SPR-HCA; ENV-2022-7048-CE), including all actions related or referring to the proposed construction of a seven-story, 151 dwelling unit mixed-use project, including 3,690 square feet of ground floor commercial uses, located at 1200-1218 N. Vine Street and 6245-6247 W. Lexington Ave. in the City of Los Angeles (“Project”).

SAFER objects to the City of Los Angeles’ (“City”) decision to exempt the Project from review under the California Environmental Quality Act (“CEQA”) pursuant to Section 15332 of the CEQA Guidelines. CEQA review is required for the Project. As demonstrated below, the Exemption is inapplicable because the Project will have significant indoor air quality impacts, precluding use of the Class 32 Exemption. Since the Project is not exempt from CEQA, an initial study must be prepared to determine the appropriate level of CEQA review required.

This comment has been prepared with the assistance of indoor air quality expert Francis “Bud” Offermann (Exhibit A). We incorporate the Offermann comments herein by reference.

PROJECT DESCRIPTION

The Project is located on an approximately 0.9-acre site that is currently developed with two commercial buildings and surface parking. The Project proposes to develop 151 multifamily residential units and approximately 3,690 square feet of ground floor commercial uses.

The site is surrounded by commercial and residential uses, including the immediately adjacent property, which contains multiple apartment buildings. Approvals from the City of Los Angeles that are necessary for the project include a Density Bonus with two off-menu incentives, a Conditional Use Permit, and Site Plan Review.

LEGAL BACKGROUND

As the California Supreme Court has held, “[i]f no EIR has been prepared for a nonexempt project, but substantial evidence in the record supports a fair argument that the project may result in significant adverse impacts, the proper remedy is to order preparation of an EIR.” (*Communities for a Better Env’t v. South Coast Air Quality Mgmt. Dist.* (2010) 48 Cal.4th 310, 319-20.) “Significant environmental effect” is defined very broadly as “a substantial or potentially substantial adverse change in the environment.” (Pub. Res. Code (“PRC”) § 21068; see also, 14 CCR § 15382.) An effect on the environment need not be “momentous” to meet the CEQA test for significance; it is enough that the impacts are “not trivial.” (*No Oil, Inc. v. City of Los Angeles* (1974) 13 Cal.3d 68, 83.) “The ‘foremost principle’ in interpreting CEQA is that the Legislature intended the act to be read so as to afford the fullest possible protection to the environment within the reasonable scope of the statutory language.” (*Communities for a Better Env’t v. Cal. Res. Agency* (2002) 103 Cal.App.4th 98, 109.)

The EIR is the very heart of CEQA. (*Bakersfield Citizens for Local Control v. City of Bakersfield* (2004) 124 Cal.App.4th 1184, 1214; *Pocket Protectors v. City of Sacramento* (2004) 124 Cal.App.4th 903, 927.) The EIR is an “environmental ‘alarm bell’ whose purpose is to alert the public and its responsible officials to environmental changes before they have reached the ecological points of no return.” (*Bakersfield Citizens*, 124 Cal.App.4th at 1220.) The EIR also functions as a “document of accountability,” intended to “demonstrate to an apprehensive citizenry that the agency has, in fact, analyzed and considered the ecological implications of its action.” (*Laurel Heights Improvements Assn. v. Regents of Univ. of Cal.* (1988) 47 Cal.3d 376, 392.) The EIR process “protects not only the environment but also informed self-government.” (*Pocket Protectors*, 124 Cal.App.4th at 927.)

To achieve its objectives of environmental protection, CEQA has a three-tiered structure. (14 CCR § 15002(k); *Committee to Save the Hollywoodland Specific Plan v. City of Los Angeles* (2008) 161 Cal.App.4th 1168, 1185-86.) First, if a project falls into an exempt category, or it can be seen with certainty that the activity in question will not have a significant effect on the environment, no further agency evaluation is required. (*Id.*) Second, if there is a possibility the project will have a significant effect on the environment, the agency must perform an initial threshold study. (*Id.*; 14 CCR § 15063(a).) If the study indicates that there is no substantial evidence that the project or any of its aspects may cause a significant effect on the environment the agency may issue a negative declaration. (*Id.*; 14 CCR §§ 15063(b)(2), 15070.) Finally, if the project will have a significant effect on the environment, an EIR is required. (*Id.*)

The classes of projects which are exempt from the provisions of CEQA are called categorical exemptions. (14 CCR §§ 15300, 15354.) “Exemptions to CEQA are narrowly construed and ‘[e]xemption categories are not to be expanded beyond the reasonable scope of their statutory language.’ [Citations].” (*Mountain Lion Foundation v. Fish & Game Com.* (1997) 16 Cal.4th 105, 125.) The determination as to the appropriate scope of a categorical exemption is a question of law subject to independent, or de novo, review. (*San Lorenzo Valley Community Advocates for Responsible Education v. San Lorenzo Valley Unified School Dist.*, (2006) 139 Cal. App. 4th 1356, 1375 [“[Q]uestions of interpretation or application of the requirements of CEQA are matters of law. [Citations.] Thus, for example, interpreting the scope of a CEQA exemption presents ‘a question of law, subject to de novo review by this court.’ [Citations].”].) In addition, there are several exceptions to CEQA’s categorical exemptions. (See, 14 CCR § 15300.2.)

DISCUSSION

I. The Class 32 Exemption Does Not Apply on its Face.

The proposed Project does not qualify for a Class 32 Exemption under CEQA because of the Project’s significant indoor air quality impacts. The City must prepare an Initial Study to determine the appropriate level of CEQA review, be it a mitigated negative declaration or an environmental impact report.

The Class 32 exemption provides:

Class 32 consists of projects characterized as in-fill development meeting the conditions described in this section.

- (a) The project is consistent with the applicable general plan designation and all applicable general plan policies as well as with applicable zoning designation and regulations.
- (b) The proposed development occurs within city limits on a project site of no more than five acres substantially surrounded by urban uses.
- (c) The project site has no value, as habitat for endangered, rare or threatened species.
- (d) *Approval of the project would not result in any significant effects relating to traffic, noise, air quality, or water quality.*
- (e) The site can be adequately served by all required utilities and public services.

(14 CCR § 15332 [emph. added].)

One of the key limitations of the Exemption is that it does not apply if the project will have any significant effects relating to air quality. (14 CCR § 15332(d).) Here, the Exemption cannot apply because, as demonstrated below, the project will have significant indoor air quality impacts.

a. There is Substantial Evidence that the Project May Have a Significant Health Risk Impact from Indoor Air Quality Impacts, Therefore the Categorical Exemption Does Not Apply.

Certified Industrial Hygienist, Francis “Bud” Offermann, PE, CIH, has conducted a review of the proposed Project and relevant documents regarding the Project’s indoor air emissions. Indoor Environmental Engineering Comments (February 5, 2023). Mr. Offermann concludes that it is likely that the Project will expose residents and commercial employees of the Project to significant impacts related to indoor air quality, and in particular, emissions of the cancer-causing chemical formaldehyde. Mr. Offermann is a leading expert on indoor air quality and has published extensively on the topic. Mr. Offermann’s expert comments and curriculum vitae are attached as Exhibit A.

Mr. Offermann explains that many composite wood products used in building materials and furnishings commonly found in offices, warehouses, residences, and hotels contain formaldehyde-based glues which off-gas formaldehyde over a very long time period. He states, “[t]he primary source of formaldehyde indoors is composite wood products manufactured with urea-formaldehyde resins, such as plywood, medium density fiberboard, and particleboard. These materials are commonly used in building construction for flooring, cabinetry, baseboards, window shades, interior doors, and window and door trims.” (Ex. A, p. 2-3).

Formaldehyde is a known human carcinogen. Mr. Offermann states that future residents of the Project would be exposed to a 120 in one million cancer risk, and commercial employees of the Project would be exposed to a 17.7 in one million risk, **even assuming** all materials are compliant with the California Air Resources Board's formaldehyde airborne toxics control measure. (*Id.* at 4-5). This potential exposure level exceeds the SCAQMD CEQA significance threshold for airborne cancer risk of 10 per million.

Mr. Offermann identifies mitigation measures that are available to reduce these significant health risks, including the installation of air filters and a requirement that the applicant use only composite wood materials (e.g. hardwood plywood, medium density fiberboard, particleboard) for all interior finish systems that are made with CARB approved no-added formaldehyde (NAF) resins or ultra-low emitting formaldehyde (ULEF) resins in the buildings' interiors. (*Id.* at 12-14). These significant environmental impacts preclude the use of a Categorical Exemption for the Project. These impacts should be reviewed in a full CEQA analysis and mitigation measures should be imposed to reduce the risk of formaldehyde exposure.

II. The Unusual Circumstances Exception Precludes Reliance on the Class 32 Exemption.

A categorical exemption is inapplicable "where there is a reasonable possibility that the activity will have a significant effect on the environment due to unusual circumstances." (14 CCR 15300.2(c).) In *Berkeley Hillside Preservation v. City of Berkeley*, the California Supreme Court explained that there are two ways a party may invoke the unusual circumstances exception. First, "a party may establish an unusual circumstance with evidence that the project *will* have a significant environmental effect. That evidence, if convincing, necessarily also establishes 'a reasonable possibility that the activity will have a significant effect on the environment due to unusual circumstances.'" (*Berkeley Hillside Preservation v. City of Berkeley* (2015) 60 Cal.4th 1086, 1105 [emph. added].) Alternatively, "[a] party invoking the exception may establish an unusual circumstance without evidence of an environmental effect, by showing that the project has some feature that distinguishes it from others in the exempt class, such as its size or location. In such a case, to render the exception applicable, the party need only show a reasonable possibility of a significant effect due to that unusual circumstance." (*Id.*)

As discussed above, the Project will have a significant air quality impact. The fact that this significant impact will occur constitutes an unusual circumstance, precluding the City's reliance on an exemption.

CONCLUSION

The City cannot rely on a Class 32 exemption because the Project does not meet the terms of the exemption and because the unusual circumstances exception to exemption applies. Accordingly, the City must prepare an initial study to determine the appropriate level of environmental review to undertake pursuant to CEQA. Thank you for considering these comments.

Sincerely,

A handwritten signature in black ink that reads "Amalia Bowley Fuentes". The signature is written in a cursive style with a large initial 'A' and a long, sweeping underline.

Amalia Bowley Fuentes
Lozeau Drury LLP

EXHIBIT A



INDOOR ENVIRONMENTAL ENGINEERING



1448 Pine Street, Suite 103 San Francisco, California 94109

Telephone: (415) 567-7700

E-mail: offermann@IEE-SF.com

<http://www.iee-sf.com>

Date: February 5, 2023

To: Amalia Bowley Fuentes
Lozeau | Drury LLP
1939 Harrison Street, Suite 150
Oakland, California 94612

From: Francis J. Offermann PE CIH

Subject: Indoor Air Quality: 1200 – 1218 N. Vine Street, 6245 - 6247 W. Lexington
Avenue Project, Los Angeles, CA
(IEE File Reference: P-4681)

Pages: 19

Indoor Air Quality Impacts

Indoor air quality (IAQ) directly impacts the comfort and health of building occupants, and the achievement of acceptable IAQ in newly constructed and renovated buildings is a well-recognized design objective. For example, IAQ is addressed by major high-performance building rating systems and building codes (California Building Standards Commission, 2014; USGBC, 2014). Indoor air quality in homes is particularly important because occupants, on average, spend approximately ninety percent of their time indoors with the majority of this time spent at home (EPA, 2011). Some segments of the population that are most susceptible to the effects of poor IAQ, such as the very young and the elderly, occupy their homes almost continuously. Additionally, an increasing number of adults are working from home at least some of the time during the workweek. Indoor air quality also is a serious concern for workers in hotels, offices and other business establishments.

The concentrations of many air pollutants often are elevated in homes and other buildings relative to outdoor air because many of the materials and products used indoors contain

and release a variety of pollutants to air (Hodgson et al., 2002; Offermann and Hodgson, 2011). With respect to indoor air contaminants for which inhalation is the primary route of exposure, the critical design and construction parameters are the provision of adequate ventilation and the reduction of indoor sources of the contaminants.

Indoor Formaldehyde Concentrations Impact. In the California New Home Study (CNHS) of 108 new homes in California (Offermann, 2009), 25 air contaminants were measured, and formaldehyde was identified as the indoor air contaminant with the highest cancer risk as determined by the California Proposition 65 Safe Harbor Levels (OEHHA, 2017a), No Significant Risk Levels (NSRL) for carcinogens. The NSRL is the daily intake level calculated to result in one excess case of cancer in an exposed population of 100,000 (i.e., ten in one million cancer risk) and for formaldehyde is 40 µg/day. The NSRL concentration of formaldehyde that represents a daily dose of 40 µg is 2 µg/m³, assuming a continuous 24-hour exposure, a total daily inhaled air volume of 20 m³, and 100% absorption by the respiratory system. All of the CNHS homes exceeded this NSRL concentration of 2 µg/m³. The median indoor formaldehyde concentration was 36 µg/m³, and ranged from 4.8 to 136 µg/m³, which corresponds to a median exceedance of the 2 µg/m³ NSRL concentration of 18 and a range of 2.3 to 68.

Therefore, the cancer risk of a resident living in a California home with the median indoor formaldehyde concentration of 36 µg/m³, is 180 per million as a result of formaldehyde alone. The CEQA significance threshold for airborne cancer risk is 10 per million, as established by the South Coast Air Quality Management District (SCAQMD, 2015).

Besides being a human carcinogen, formaldehyde is also a potent eye and respiratory irritant. In the CNHS, many homes exceeded the non-cancer reference exposure levels (RELs) prescribed by California Office of Environmental Health Hazard Assessment (OEHHA, 2017b). The percentage of homes exceeding the RELs ranged from 98% for the Chronic REL of 9 µg/m³ to 28% for the Acute REL of 55 µg/m³.

The primary source of formaldehyde indoors is composite wood products manufactured with urea-formaldehyde resins, such as plywood, medium density fiberboard, and

particleboard. These materials are commonly used in building construction for flooring, cabinetry, baseboards, window shades, interior doors, and window and door trims.

In January 2009, the California Air Resources Board (CARB) adopted an airborne toxics control measure (ATCM) to reduce formaldehyde emissions from composite wood products, including hardwood plywood, particleboard, medium density fiberboard, and also furniture and other finished products made with these wood products (California Air Resources Board 2009). While this formaldehyde ATCM has resulted in reduced emissions from composite wood products sold in California, they do not preclude that homes built with composite wood products meeting the CARB ATCM will have indoor formaldehyde concentrations below cancer and non-cancer exposure guidelines.

A follow up study to the California New Home Study (CNHS) was conducted in 2016-2018 (Singer et. al., 2019), and found that the median indoor formaldehyde in new homes built after 2009 with CARB Phase 2 Formaldehyde ATCM materials had lower indoor formaldehyde concentrations, with a median indoor concentrations of $22.4 \mu\text{g}/\text{m}^3$ (18.2 ppb) as compared to a median of $36 \mu\text{g}/\text{m}^3$ found in the 2007 CNHS. Unlike in the CNHS study where formaldehyde concentrations were measured with pumped DNPH samplers, the formaldehyde concentrations in the HENGH study were measured with passive samplers, which were estimated to under-measure the true indoor formaldehyde concentrations by approximately 7.5%. Applying this correction to the HENGH indoor formaldehyde concentrations results in a median indoor concentration of $24.1 \mu\text{g}/\text{m}^3$, which is 33% lower than the $36 \mu\text{g}/\text{m}^3$ found in the 2007 CNHS.

Thus, while new homes built after the 2009 CARB formaldehyde ATCM have a 33% lower median indoor formaldehyde concentration and cancer risk, the median lifetime cancer risk is still 120 per million for homes built with CARB compliant composite wood products. This median lifetime cancer risk is more than 12 times the OEHHA 10 in a million cancer risk threshold (OEHHA, 2017a).

With respect to the 1200 – 1218 N. Vine Street, 6245 - 6247 W. Lexington Avenue Project, Los Angeles, CA, the buildings consist of residential and commercial spaces.

The residential occupants will potentially have continuous exposure (e.g. 24 hours per day, 52 weeks per year). These exposures are anticipated to result in significant cancer risks resulting from exposures to formaldehyde released by the building materials and furnishing commonly found in residential construction.

Because these residences will be constructed with CARB Phase 2 Formaldehyde ATCM materials, and be ventilated with the minimum code required amount of outdoor air, the indoor residential formaldehyde concentrations are likely similar to those concentrations observed in residences built with CARB Phase 2 Formaldehyde ATCM materials, which is a median of 24.1 $\mu\text{g}/\text{m}^3$ (Singer et. al., 2020).

Assuming that the residential occupants inhale 20 m^3 of air per day, the average 70-year lifetime formaldehyde daily dose is 482 $\mu\text{g}/\text{day}$ for continuous exposure in the residences. This exposure represents a cancer risk of 120 per million, which is more than 12 times the CEQA cancer risk of 10 per million. For occupants that do not have continuous exposure, the cancer risk will be proportionally less but still substantially over the CEQA cancer risk of 10 per million (e.g. for 12/hour/day occupancy, more than 6 times the CEQA cancer risk of 10 per million).

The employees of the commercial spaces are expected to experience significant indoor exposures (e.g., 40 hours per week, 50 weeks per year). These exposures for employees are anticipated to result in significant cancer risks resulting from exposures to formaldehyde released by the building materials and furnishing commonly found in offices, warehouses, residences and hotels.

Because the commercial spaces will be constructed with CARB Phase 2 Formaldehyde ATCM materials, and be ventilated with the minimum code required amount of outdoor air, the indoor formaldehyde concentrations are likely similar to those concentrations observed in residences built with CARB Phase 2 Formaldehyde ATCM materials, which is a median of 24.1 $\mu\text{g}/\text{m}^3$ (Singer et. al., 2020)

Assuming that the employees of commercial spaces work 8 hours per day and inhale 20 m^3

of air per day, the formaldehyde dose per work-day at the offices is 161 µg/day.

Assuming that these employees work 5 days per week and 50 weeks per year for 45 years (start at age 20 and retire at age 65) the average 70-year lifetime formaldehyde daily dose is 70.9 µg/day.

This is 1.77 times the NSRL (OEHHA, 2017a) of 40 µg/day and represents a cancer risk of 17.7 per million, which exceeds the CEQA cancer risk of 10 per million. This impact should be analyzed in an environmental impact report (“EIR”), and the agency should impose all feasible mitigation measures to reduce this impact. Several feasible mitigation measures are discussed below and these and other measures should be analyzed in an EIR.

In addition, we note that the average outdoor air concentration of formaldehyde in California is 3 ppb, or 3.7 µg/m³, (California Air Resources Board, 2004), and thus represents an average pre-existing background airborne cancer risk of 1.85 per million. Thus, the indoor air formaldehyde exposures describe above exacerbate this pre-existing risk resulting from outdoor air formaldehyde exposures.

Additionally, the SCAQMD’s Multiple Air Toxics Exposure Study (“MATES V”) identifies an existing cancer risk at the Project site of 541 per million due to the site’s elevated ambient air contaminant concentrations, which are due to the area’s high levels of vehicle traffic. These impacts would further exacerbate the pre-existing cancer risk to the building occupants, which result from exposure to formaldehyde in both indoor and outdoor air.

Appendix A, Indoor Formaldehyde Concentrations and the CARB Formaldehyde ATCM, provides analyses that show utilization of CARB Phase 2 Formaldehyde ATCM materials will not ensure acceptable cancer risks with respect to formaldehyde emissions from composite wood products.

Even composite wood products manufactured with CARB certified ultra low emitting formaldehyde (ULEF) resins do not insure that the indoor air will have concentrations of

formaldehyde the meet the OEHHA cancer risks that substantially exceed 10 per million. The permissible emission rates for ULEF composite wood products are only 11-15% lower than the CARB Phase 2 emission rates. Only use of composite wood products made with no-added formaldehyde resins (NAF), such as resins made from soy, polyvinyl acetate, or methylene diisocyanate can insure that the OEHHA cancer risk of 10 per million is met.

The following describes a method that should be used, prior to construction in the environmental review under CEQA, for determining whether the indoor concentrations resulting from the formaldehyde emissions of specific building materials/furnishings selected exceed cancer and non-cancer guidelines. Such a design analyses can be used to identify those materials/furnishings prior to the completion of the City's CEQA review and project approval, that have formaldehyde emission rates that contribute to indoor concentrations that exceed cancer and non-cancer guidelines, so that alternative lower emitting materials/furnishings may be selected and/or higher minimum outdoor air ventilation rates can be increased to achieve acceptable indoor concentrations and incorporated as mitigation measures for this project.

Pre-Construction Building Material/Furnishing Formaldehyde Emissions Assessment

This formaldehyde emissions assessment should be used in the environmental review under CEQA to assess the indoor formaldehyde concentrations from the proposed loading of building materials/furnishings, the area-specific formaldehyde emission rate data for building materials/furnishings, and the design minimum outdoor air ventilation rates. This assessment allows the applicant (and the City) to determine, before the conclusion of the environmental review process and the building materials/furnishings are specified, purchased, and installed, if the total chemical emissions will exceed cancer and non-cancer guidelines, and if so, allow for changes in the selection of specific material/furnishings and/or the design minimum outdoor air ventilations rates such that cancer and non-cancer guidelines are not exceeded.

1.) Define Indoor Air Quality Zones. Divide the building into separate indoor air quality zones, (IAQ Zones). IAQ Zones are defined as areas of well-mixed air. Thus, each ventilation system with recirculating air is considered a single zone, and each room or

group of rooms where air is not recirculated (e.g. 100% outdoor air) is considered a separate zone. For IAQ Zones with the same construction material/furnishings and design minimum outdoor air ventilation rates. (e.g. hotel rooms, apartments, condominiums, etc.) the formaldehyde emission rates need only be assessed for a single IAQ Zone of that type.

2.) Calculate Material/Furnishing Loading. For each IAQ Zone, determine the building material and furnishing loadings (e.g., m² of material/m² floor area, units of furnishings/m² floor area) from an inventory of all potential indoor formaldehyde sources, including flooring, ceiling tiles, furnishings, finishes, insulation, sealants, adhesives, and any products constructed with composite wood products containing urea-formaldehyde resins (e.g., plywood, medium density fiberboard, particleboard).

3.) Calculate the Formaldehyde Emission Rate. For each building material, calculate the formaldehyde emission rate (µg/h) from the product of the area-specific formaldehyde emission rate (µg/m²-h) and the area (m²) of material in the IAQ Zone, and from each furnishing (e.g. chairs, desks, etc.) from the unit-specific formaldehyde emission rate (µg/unit-h) and the number of units in the IAQ Zone.

NOTE: As a result of the high-performance building rating systems and building codes (California Building Standards Commission, 2014; USGBC, 2014), most manufacturers of building materials furnishings sold in the United States conduct chemical emission rate tests using the California Department of Health “Standard Method for the Testing and Evaluation of Volatile Organic Chemical Emissions for Indoor Sources Using Environmental Chambers,” (CDPH, 2017), or other equivalent chemical emission rate testing methods. Most manufacturers of building furnishings sold in the United States conduct chemical emission rate tests using ANSI/BIFMA M7.1 Standard Test Method for Determining VOC Emissions (BIFMA, 2018), or other equivalent chemical emission rate testing methods.

CDPH, BIFMA, and other chemical emission rate testing programs, typically certify that a material or furnishing does not create indoor chemical concentrations in excess of the maximum concentrations permitted by their certification. For instance, the CDPH emission rate testing requires that the measured emission rates when input into an office, school, or

residential model do not exceed one-half of the OEHHA Chronic Exposure Guidelines (OEHHA, 2017b) for the 35 specific VOCs, including formaldehyde, listed in Table 4-1 of the CDPH test method (CDPH, 2017). These certifications themselves do not provide the actual area-specific formaldehyde emission rate (i.e., $\mu\text{g}/\text{m}^2\text{-h}$) of the product, but rather provide data that the formaldehyde emission rates do not exceed the maximum rate allowed for the certification. Thus, for example, the data for a certification of a specific type of flooring may be used to calculate that the area-specific emission rate of formaldehyde is less than $31 \mu\text{g}/\text{m}^2\text{-h}$, but not the actual measured specific emission rate, which may be 3, 18, or $30 \mu\text{g}/\text{m}^2\text{-h}$. These area-specific emission rates determined from the product certifications of CDPH, BIFA, and other certification programs can be used as an initial estimate of the formaldehyde emission rate.

If the actual area-specific emission rates of a building material or furnishing is needed (i.e. the initial emission rates estimates from the product certifications are higher than desired), then that data can be acquired by requesting from the manufacturer the complete chemical emission rate test report. For instance if the complete CDPH emission test report is requested for a CDHP certified product, that report will provide the actual area-specific emission rates for not only the 35 specific VOCs, including formaldehyde, listed in Table 4-1 of the CDPH test method (CDPH, 2017), but also all of the cancer and reproductive/developmental chemicals listed in the California Proposition 65 Safe Harbor Levels (OEHHA, 2017a), all of the toxic air contaminants (TACs) in the California Air Resources Board Toxic Air Contamination List (CARB, 2011), and the 10 chemicals with the greatest emission rates.

Alternatively, a sample of the building material or furnishing can be submitted to a chemical emission rate testing laboratory, such as Berkeley Analytical Laboratory (<https://berkeleyanalytical.com>), to measure the formaldehyde emission rate.

4.) Calculate the Total Formaldehyde Emission Rate. For each IAQ Zone, calculate the total formaldehyde emission rate (i.e. $\mu\text{g}/\text{h}$) from the individual formaldehyde emission rates from each of the building material/furnishings as determined in Step 3.

5.) Calculate the Indoor Formaldehyde Concentration. For each IAQ Zone, calculate the indoor formaldehyde concentration ($\mu\text{g}/\text{m}^3$) from Equation 1 by dividing the total formaldehyde emission rates (i.e. $\mu\text{g}/\text{h}$) as determined in Step 4, by the design minimum outdoor air ventilation rate (m^3/h) for the IAQ Zone.

$$C_{in} = \frac{E_{total}}{Q_{oa}} \quad (\text{Equation 1})$$

where:

C_{in} = indoor formaldehyde concentration ($\mu\text{g}/\text{m}^3$)

E_{total} = total formaldehyde emission rate ($\mu\text{g}/\text{h}$) into the IAQ Zone.

Q_{oa} = design minimum outdoor air ventilation rate to the IAQ Zone (m^3/h)

The above Equation 1 is based upon mass balance theory, and is referenced in Section 3.10.2 “Calculation of Estimated Building Concentrations” of the California Department of Health “Standard Method for the Testing and Evaluation of Volatile Organic Chemical Emissions for Indoor Sources Using Environmental Chambers”, (CDPH, 2017).

6.) Calculate the Indoor Exposure Cancer and Non-Cancer Health Risks. For each IAQ Zone, calculate the cancer and non-cancer health risks from the indoor formaldehyde concentrations determined in Step 5 and as described in the OEHHA Air Toxics Hot Spots Program Risk Assessment Guidelines; Guidance Manual for Preparation of Health Risk Assessments (OEHHA, 2015).

7.) Mitigate Indoor Formaldehyde Exposures of exceeding the CEQA Cancer and/or Non-Cancer Health Risks. In each IAQ Zone, provide mitigation for any formaldehyde exposure risk as determined in Step 6, that exceeds the CEQA cancer risk of 10 per million or the CEQA non-cancer Hazard Quotient of 1.0.

Provide the source and/or ventilation mitigation required in all IAQ Zones to reduce the health risks of the chemical exposures below the CEQA cancer and non-cancer health risks.

Source mitigation for formaldehyde may include:

- 1.) reducing the amount materials and/or furnishings that emit formaldehyde

- 2.) substituting a different material with a lower area-specific emission rate of formaldehyde

Ventilation mitigation for formaldehyde emitted from building materials and/or furnishings may include:

- 1.) increasing the design minimum outdoor air ventilation rate to the IAQ Zone.

NOTE: Mitigating the formaldehyde emissions through use of less material/furnishings, or use of lower emitting materials/furnishings, is the preferred mitigation option, as mitigation with increased outdoor air ventilation increases initial and operating costs associated with the heating/cooling systems.

Further, we are not asking that the builder “speculate” on what and how much composite materials be used, but rather at the design stage to select composite wood materials based on the formaldehyde emission rates that manufacturers routinely conduct using the California Department of Health “Standard Method for the Testing and Evaluation of Volatile Organic Chemical Emissions for Indoor Sources Using Environmental Chambers,” (CDPH, 2017), and use the procedure described earlier above (i.e. Pre-Construction Building Material/Furnishing Formaldehyde Emissions Assessment) to insure that the materials selected achieve acceptable cancer risks from material off gassing of formaldehyde.

Outdoor Air Ventilation Impact. Another important finding of the CNHS, was that the outdoor air ventilation rates in the homes were very low. Outdoor air ventilation is a very important factor influencing the indoor concentrations of air contaminants, as it is the primary removal mechanism of all indoor air generated contaminants. Lower outdoor air exchange rates cause indoor generated air contaminants to accumulate to higher indoor air concentrations. Many homeowners rarely open their windows or doors for ventilation as a result of their concerns for security/safety, noise, dust, and odor concerns (Price, 2007). In the CNHS field study, 32% of the homes did not use their windows during the 24-hour Test Day, and 15% of the homes did not use their windows during the entire preceding week. Most of the homes with no window usage were homes in the winter field session. Thus, a

substantial percentage of homeowners never open their windows, especially in the winter season. The median 24-hour measurement was 0.26 air changes per hour (ach), with a range of 0.09 ach to 5.3 ach. A total of 67% of the homes had outdoor air exchange rates below the minimum California Building Code (2001) requirement of 0.35 ach. Thus, the relatively tight envelope construction, combined with the fact that many people never open their windows for ventilation, results in homes with low outdoor air exchange rates and higher indoor air contaminant concentrations.

According to the Environmental Assessment Form Application, 1200 – 1218 N. Vine Street, 6245 - 6247 W. Lexington Avenue Project (City of Los Angeles, 2022) the Project is close to roads with moderate to high traffic (e.g., Santa Monica Blvd - 66, Vine Street, Lexington Avenue, Fountain Avenue, N. El Cento Avenue, N. Cahuenga Blvd, etc.). As a result the Project site is a sound impacted site.

In order to design the building for this Project such that interior noise levels are acceptable, an acoustic study of the existing and future ambient noise levels needs to be conducted.

As a result of the high outdoor noise levels, the current project will require a mechanical supply of outdoor air ventilation to allow for a habitable interior environment with closed windows and doors. Such a ventilation system would allow windows and doors to be kept closed at the occupant's discretion to control exterior noise within building interiors.

PM_{2.5} Outdoor Concentrations Impact. An additional impact of the nearby motor vehicle traffic associated with this project, are the outdoor concentrations of PM_{2.5}. According to the Environmental Assessment Form Application, 1200 – 1218 N. Vine Street, 6245 - 6247 W. Lexington Avenue Project (City of Los Angeles, 2022), the Project is located in the South Coast Air Basin, which is a State and Federal non-attainment area for PM_{2.5}.

Additionally, the SCAQMD's MATES V study cites an existing cancer risk of 541 per million at the Project site due to the site's high concentration of ambient air contaminants resulting from the area's high levels of motor vehicle traffic.

An air quality analyses should be conducted to determine the concentrations of PM_{2.5} in the outdoor and indoor air that people inhale each day. This air quality analyses needs to consider the cumulative impacts of the project related emissions, existing and projected future emissions from local PM_{2.5} sources (e.g. stationary sources, motor vehicles, and airport traffic) upon the outdoor air concentrations at the Project site. If the outdoor concentrations are determined to exceed the California and National annual average PM_{2.5} exceedence concentration of 12 µg/m³, or the National 24-hour average exceedence concentration of 35 µg/m³, then the buildings need to have a mechanical supply of outdoor air that has air filtration with sufficient removal efficiency, such that the indoor concentrations of outdoor PM_{2.5} particles is less than the California and National PM_{2.5} annual and 24-hour standards.

It is my experience that based on the projected high traffic noise levels, the annual average concentration of PM_{2.5} will exceed the California and National PM_{2.5} annual and 24-hour standards and warrant installation of high efficiency air filters (i.e. MERV 13 or higher) in all mechanically supplied outdoor air ventilation systems.

Indoor Air Quality Impact Mitigation Measures

The following are recommended mitigation measures to minimize the impacts upon indoor quality:

Indoor Formaldehyde Concentrations Mitigation. Use only composite wood materials (e.g. hardwood plywood, medium density fiberboard, particleboard) for all interior finish systems that are made with CARB approved no-added formaldehyde (NAF) resins (CARB, 2009). CARB Phase 2 certified composite wood products, or ultra-low emitting formaldehyde (ULEF) resins, do not insure indoor formaldehyde concentrations that are below the CEQA cancer risk of 10 per million. Only composite wood products manufactured with CARB approved no-added formaldehyde (NAF) resins, such as resins made from soy, polyvinyl acetate, or methylene diisocyanate can insure that the OEHHA cancer risk of 10 per million is met.

Alternatively, conduct the previously described Pre-Construction Building Material/Furnishing Chemical Emissions Assessment, to determine that the combination of formaldehyde emissions from building materials and furnishings do not create indoor formaldehyde concentrations that exceed the CEQA cancer and non-cancer health risks.

It is important to note that we are not asking that the builder “speculate” on what and how much composite materials be used, but rather at the design stage to select composite wood materials based on the formaldehyde emission rates that manufacturers routinely conduct using the California Department of Health “Standard Method for the Testing and Evaluation of Volatile Organic Chemical Emissions for Indoor Sources Using Environmental Chambers”, (CDPH, 2017), and use the procedure described above (i.e. Pre-Construction Building Material/Furnishing Formaldehyde Emissions Assessment) to insure that the materials selected achieve acceptable cancer risks from material off gassing of formaldehyde.

Outdoor Air Ventilation Mitigation. Provide each habitable room with a continuous mechanical supply of outdoor air that meets or exceeds the California 2016 Building Energy Efficiency Standards (California Energy Commission, 2015) requirements of the greater of 15 cfm/occupant or 0.15 cfm/ft² of floor area. Following installation of the system conduct testing and balancing to insure that required amount of outdoor air is entering each habitable room and provide a written report documenting the outdoor airflow rates. Do not use exhaust only mechanical outdoor air systems, use only balanced outdoor air supply and exhaust systems or outdoor air supply only systems. Provide a manual for the occupants or maintenance personnel, that describes the purpose of the mechanical outdoor air system and the operation and maintenance requirements of the system.

PM_{2.5} Outdoor Air Concentration Mitigation. Install air filtration with sufficient PM_{2.5} removal efficiency (e.g. MERV 13 or higher) to filter the outdoor air entering the mechanical outdoor air supply systems, such that the indoor concentrations of outdoor PM_{2.5} particles are less than the California and National PM_{2.5} annual and 24-hour standards. Install the air filters in the system such that they are accessible for replacement by the occupants or maintenance personnel. Include in the mechanical outdoor air ventilation

system manual instructions on how to replace the air filters and the estimated frequency of replacement.

References

BIFA. 2018. BIFMA Product Safety and Performance Standards and Guidelines. www.bifma.org/page/standardsoverview

California Air Resources Board. 2009. Airborne Toxic Control Measure to Reduce Formaldehyde Emissions from Composite Wood Products. California Environmental Protection Agency, Sacramento, CA.

<https://www.arb.ca.gov/regact/2007/compwood07/fro-final.pdf>

California Air Resources Board. 2011. Toxic Air Contaminant Identification List. California Environmental Protection Agency, Sacramento, CA.

<https://www.arb.ca.gov/toxics/id/taclist.htm>

California Building Code. 2001. California Code of Regulations, Title 24, Part 2 Volume 1, Appendix Chapter 12, Interior Environment, Division 1, Ventilation, Section 1207: 2001 California Building Code, California Building Standards Commission. Sacramento, CA.

California Building Standards Commission (2014). 2013 California Green Building Standards Code. California Code of Regulations, Title 24, Part 11. California Building Standards Commission, Sacramento, CA <http://www.bsc.ca.gov/Home/CALGreen.aspx>.

California Energy Commission, PIER Program. CEC-500-2007-033. Final Report, ARB Contract 03-326. Available at: www.arb.ca.gov/research/apr/past/03-326.pdf.

California Energy Commission, 2015. 2016 Building Energy Efficiency Standards for Residential and Nonresidential Buildings, California Code of Regulations, Title 24, Part 6. <http://www.energy.ca.gov/2015publications/CEC-400-2015-037/CEC-400-2015-037-CMF.pdf>

CDPH. 2017. Standard Method for the Testing and Evaluation of Volatile Organic Chemical Emissions for Indoor Sources Using Environmental Chambers, Version 1.1. California Department of Public Health, Richmond, CA. <https://www.cdph.ca.gov/Programs/CCDPHP/DEODC/EHLB/IAQ/Pages/VOC.aspx>.

City of Los Angeles 2022. Environmental Assessment Form Application, 1200 – 1218 N. Vine Street, 6245 - 6247 W. Lexington Avenue Project.

EPA. 2011. Exposure Factors Handbook: 2011 Edition, Chapter 16 – Activity Factors. Report EPA/600/R-09/052F, September 2011. U.S. Environmental Protection Agency, Washington, D.C.

Hodgson, A. T., D. Beal, J.E.R. McIlvaine. 2002. Sources of formaldehyde, other aldehydes and terpenes in a new manufactured house. *Indoor Air* 12: 235–242.

OEHHA (Office of Environmental Health Hazard Assessment). 2015. Air Toxics Hot Spots Program Risk Assessment Guidelines; Guidance Manual for Preparation of Health Risk Assessments.

OEHHA (Office of Environmental Health Hazard Assessment). 2017a. Proposition 65 Safe Harbor Levels. No Significant Risk Levels for Carcinogens and Maximum Allowable Dose Levels for Chemicals Causing Reproductive Toxicity. Available at: <http://www.oehha.ca.gov/prop65/pdf/safeharbor081513.pdf>

OEHHA - Office of Environmental Health Hazard Assessment. 2017b. All OEHHA Acute, 8-hour and Chronic Reference Exposure Levels. Available at: <http://oehha.ca.gov/air/allrels.html>

Offermann, F. J. 2009. Ventilation and Indoor Air Quality in New Homes. California Air Resources Board and California Energy Commission, PIER Energy-Related Environmental

Research Program. Collaborative Report. CEC-500-2009-085.
<https://www.arb.ca.gov/research/apr/past/04-310.pdf>

Offermann, F. J. and A. T. Hodgson. 2011. Emission Rates of Volatile Organic Compounds in New Homes. Proceedings Indoor Air 2011 (12th International Conference on Indoor Air Quality and Climate 2011), June 5-10, 2011, Austin, TX.

Singer, B.C, Chan, W.R, Kim, Y., Offermann, F.J., and Walker I.S. 2020. Indoor Air Quality in California Homes with Code-Required Mechanical Ventilation. Indoor Air, Vol 30, Issue 5, 885-899.

South Coast Air Quality Management District (SCAQMD). 2015. California Environmental Quality Act Air Quality Handbook. South Coast Air Quality Management District, Diamond Bar, CA, <http://www.aqmd.gov/home/rules-compliance/ceqa/air-quality-analysis-handbook>

USGBC. 2014. LEED BD+C Homes v4. U.S. Green Building Council, Washington, D.C.
<http://www.usgbc.org/credits/homes/v4>

APPENDIX A

INDOOR FORMALDEHYDE CONCENTRATIONS AND THE CARB FORMALDEHYDE ATCM

With respect to formaldehyde emissions from composite wood products, the CARB ATCM regulations of formaldehyde emissions from composite wood products, do not assure healthful indoor air quality. The following is the stated purpose of the CARB ATCM regulation - *The purpose of this airborne toxic control measure is to “reduce formaldehyde emissions from composite wood products, and finished goods that contain composite wood products, that are sold, offered for sale, supplied, used, or manufactured for sale in California”*. In other words, the CARB ATCM regulations do not “assure healthful indoor air quality”, but rather “reduce formaldehyde emissions from composite wood products”.

Just how much protection do the CARB ATCM regulations provide building occupants from the formaldehyde emissions generated by composite wood products? Definitely some, but certainly the regulations do not “*assure healthful indoor air quality*” when CARB Phase 2 products are utilized. As shown in the Chan 2019 study of new California homes, the median indoor formaldehyde concentration was of 22.4 $\mu\text{g}/\text{m}^3$ (18.2 ppb), which corresponds to a cancer risk of 112 per million for occupants with continuous exposure, which is more than 11 times the CEQA cancer risk of 10 per million.

Another way of looking at how much protection the CARB ATCM regulations provide building occupants from the formaldehyde emissions generated by composite wood products is to calculate the maximum number of square feet of composite wood product that can be in a residence without exceeding the CEQA cancer risk of 10 per million for occupants with continuous occupancy.

For this calculation I utilized the floor area (2,272 ft^2), the ceiling height (8.5 ft), and the number of bedrooms (4) as defined in Appendix B (New Single-Family Residence Scenario) of the Standard Method for the Testing and Evaluation of Volatile Organic Chemical Emissions for Indoor Sources Using Environmental Chambers, Version 1.1, 2017, California Department of Public Health,

For the outdoor air ventilation rate I used the 2019 Title 24 code required mechanical ventilation rate (ASHRAE 62.2) of 106 cfm (180 m³/h) calculated for this model residence. For the composite wood formaldehyde emission rates I used the CARB ATCM Phase 2 rates.

The calculated maximum number of square feet of composite wood product that can be in a residence, without exceeding the CEQA cancer risk of 10 per million for occupants with continuous occupancy are as follows for the different types of regulated composite wood products.

Medium Density Fiberboard (MDF) – 15 ft² (0.7% of the floor area), or
Particle Board – 30 ft² (1.3% of the floor area), or
Hardwood Plywood – 54 ft² (2.4% of the floor area), or
Thin MDF – 46 ft² (2.0 % of the floor area).

For offices and hotels the calculated maximum amount of composite wood product (% of floor area) that can be used without exceeding the CEQA cancer risk of 10 per million for occupants, assuming 8 hours/day occupancy, and the California Mechanical Code minimum outdoor air ventilation rates are as follows for the different types of regulated composite wood products.

Medium Density Fiberboard (MDF) – 3.6 % (offices) and 4.6% (hotel rooms), or
Particle Board – 7.2 % (offices) and 9.4% (hotel rooms), or
Hardwood Plywood – 13 % (offices) and 17% (hotel rooms), or
Thin MDF – 11 % (offices) and 14 % (hotel rooms)

Clearly the CARB ATCM does not regulate the formaldehyde emissions from composite wood products such that the potentially large areas of these products, such as for flooring, baseboards, interior doors, window and door trims, and kitchen and bathroom cabinetry, could be used without causing indoor formaldehyde concentrations that result in CEQA

cancer risks that substantially exceed 10 per million for occupants with continuous occupancy.

Even composite wood products manufactured with CARB certified ultra low emitting formaldehyde (ULEF) resins do not insure that the indoor air will have concentrations of formaldehyde that meet the OEHHA cancer risks that substantially exceed 10 per million. The permissible emission rates for ULEF composite wood products are only 11-15% lower than the CARB Phase 2 emission rates. Only use of composite wood products made with no-added formaldehyde resins (NAF), such as resins made from soy, polyvinyl acetate, or methylene diisocyanate can insure that the OEHHA cancer risk of 10 per million is met.

If CARB Phase 2 compliant or ULEF composite wood products are utilized in construction, then the resulting indoor formaldehyde concentrations should be determined in the design phase using the specific amounts of each type of composite wood product, the specific formaldehyde emission rates, and the volume and outdoor air ventilation rates of the indoor spaces, and all feasible mitigation measures employed to reduce this impact (e.g. use less formaldehyde containing composite wood products and/or incorporate mechanical systems capable of higher outdoor air ventilation rates). See the procedure described earlier (i.e. Pre-Construction Building Material/Furnishing Formaldehyde Emissions Assessment) to insure that the materials selected achieve acceptable cancer risks from material off gassing of formaldehyde.

Alternatively, and perhaps a simpler approach, is to use only composite wood products (e.g. hardwood plywood, medium density fiberboard, particleboard) for all interior finish systems that are made with CARB approved no-added formaldehyde (NAF) resins.

P: (626) 381-9248
F: (626) 389-5414
E: info@mitschsailaw.com



Mitchell M. Tsai
Attorney At Law

139 South Hudson Avenue
Suite 200
Pasadena, California 91101

VIA E-MAIL

April 27, 2023

Stephanie Escobar
City of Los Angeles
200 N. Spring Street, Suite 525
Los Angeles, CA 90012
Em: stephanie.escobar@lacity.org

RE: 1200-1218 N. Vine St. Project [ENV-2022-7048-CE]

Dear Honorable Commissioners,

On behalf of the Southwest Mountain States Regional Council of Carpenters (“**The Carpenters**” or “**SWMSRCC**”), my Office is submitting these comments to the City of Los Angeles (“**City**”) regarding the 1200-1218 N. Vine Street project (“**Project**”).

SWMSRCC is a labor union representing 50,000 union carpenters in six states, including California, and has a strong interest in well ordered land use planning and addressing the environmental impacts of development projects. Individual members of the Southwest Carpenters live, work and recreate in the City and surrounding communities and would be directly affected by the Project’s environmental impacts.

SWMSRCC expressly reserves the right to supplement these comments at or prior to hearings on the Project, and at any later hearings and proceedings related to this Project. Cal. Gov. Code § 65009(b); Cal. Pub. Res. Code § 21177(a); *Bakersfield Citizens for Local Control v. Bakersfield* (2004) 124 Cal. App. 4th 1184, 1199-1203; see *Galante Vineyards v. Monterey Water Dist.* (1997) 60 Cal. App. 4th 1109, 1121.

SWMSRCC incorporates by reference all comments raising issues regarding the Project’s environmental review submitted prior to approval of the Project. *Citizens for Clean Energy v. City of Woodland* (2014) 225 Cal. App. 4th 173, 191 (finding that any party who has objected to the Project’s environmental documentation may assert any issue timely raised by other parties).

SWMSRCC also requests that the City provide notice for any and all notices referring or related to the Project issued under the California Environmental Quality Act

(“**CEQA**”), Cal Public Resources Code (“**PRC**”) § 21000 *et seq.*, and the California Planning and Zoning Law (“**Planning and Zoning Law**”), Cal. Gov’t Code §§ 65000–65010. California Public Resources Code Sections 21092.2, and 21167(f) and Government Code Section 65092 require agencies to mail such notices to any person who has filed a written request for them with the clerk of the agency’s governing body.

I. THE CITY SHOULD REQUIRE THE USE OF A LOCAL WORKFORCE TO BENEFIT THE COMMUNITY’S ECONOMIC DEVELOPMENT AND ENVIRONMENT

As noted in our previous letters, the City should require the Project to be built using a local workers who have graduated from a Joint Labor-Management Apprenticeship Program approved by the State of California, have at least as many hours of on-the-job experience in the applicable craft which would be required to graduate from such a state-approved apprenticeship training program, or who are registered apprentices in a state-approved apprenticeship training program.

Community benefits such as local hire can also be helpful to reduce environmental impacts and improve the positive economic impact of the Project. Local hire provisions requiring that a certain percentage of workers reside within 10 miles or less of the Project site can reduce the length of vendor trips, reduce greenhouse gas emissions, and provide localized economic benefits. As environmental consultants Matt Hagemann and Paul E. Rosenfeld note:

[A]ny local hire requirement that results in a decreased worker trip length from the default value has the potential to result in a reduction of construction-related GHG emissions, though the significance of the reduction would vary based on the location and urbanization level of the project site.

March 8, 2021 SWAPE Letter to Mitchell M. Tsai re Local Hire Requirements and Considerations for Greenhouse Gas Modeling.

Workforce requirements promote the development of skilled trades that yield sustainable economic development. As the California Workforce Development Board and the University of California, Berkeley Center for Labor Research and Education concluded:

[L]abor should be considered an investment rather than a cost—and investments in growing, diversifying, and upskilling California’s workforce

can positively affect returns on climate mitigation efforts. In other words, well-trained workers are key to delivering emissions reductions and moving California closer to its climate targets.¹

Furthermore, workforce policies have significant environmental benefits given that they improve an area’s jobs-housing balance, decreasing the amount and length of job commutes and the associated greenhouse gas (“**GHG**”) emissions. In fact, on May 7, 2021, the South Coast Air Quality Management District found that that the “[u]se of a local state-certified apprenticeship program” can result in air pollutant reductions.²

Locating jobs closer to residential areas can have significant environmental benefits. As the California Planning Roundtable noted in 2008:

People who live and work in the same jurisdiction would be more likely to take transit, walk, or bicycle to work than residents of less balanced communities and their vehicle trips would be shorter. Benefits would include potential reductions in both vehicle miles traveled and vehicle hours traveled.³

Moreover, local hire mandates and skill-training are critical facets of a strategy to reduce vehicle miles traveled (“**VMT**”). As planning experts Robert Cervero and Michael Duncan have noted, simply placing jobs near housing stock is insufficient to achieve VMT reductions given that the skill requirements of available local jobs must match those held by local residents.⁴ Some municipalities have even tied local hire and

¹ California Workforce Development Board (2020) Putting California on the High Road: A Jobs and Climate Action Plan for 2030 at p. ii, *available at* <https://laborcenter.berkeley.edu/wp-content/uploads/2020/09/Putting-California-on-the-High-Road.pdf>.

² South Coast Air Quality Management District (May 7, 2021) Certify Final Environmental Assessment and Adopt Proposed Rule 2305 – Warehouse Indirect Source Rule – Warehouse Actions and Investments to Reduce Emissions Program, and Proposed Rule 316 – Fees for Rule 2305, Submit Rule 2305 for Inclusion Into the SIP, and Approve Supporting Budget Actions, *available at* <http://www.aqmd.gov/docs/default-source/Agendas/Governing-Board/2021/2021-May7-027.pdf?sfvrsn=10>.

³ California Planning Roundtable (2008) Deconstructing Jobs-Housing Balance at p. 6, *available at* <https://cproundtable.org/static/media/uploads/publications/cpr-jobs-housing.pdf>

⁴ Cervero, Robert and Duncan, Michael (2006) Which Reduces Vehicle Travel More: Jobs-Housing Balance or Retail-Housing Mixing? *Journal of the American Planning Association* 72 (4), 475-490, 482, *available at* <http://reconnectingamerica.org/assets/Uploads/UTCT-825.pdf>.

other workforce policies to local development permits to address transportation issues. Cervero and Duncan note that:

In nearly built-out Berkeley, CA, the approach to balancing jobs and housing is to create local jobs rather than to develop new housing. The city’s First Source program encourages businesses to hire local residents, especially for entry- and intermediate-level jobs, and sponsors vocational training to ensure residents are employment-ready. While the program is voluntary, some 300 businesses have used it to date, placing more than 3,000 city residents in local jobs since it was launched in 1986. When needed, these carrots are matched by sticks, since the city is not shy about negotiating corporate participation in First Source as a condition of approval for development permits.

Recently, the State of California verified its commitment towards workforce development through the Affordable Housing and High Road Jobs Act of 2022, otherwise known as Assembly Bill No. 2011 (“**AB2011**”). AB2011 amended the Planning and Zoning Law to allow ministerial, by-right approval for projects being built alongside commercial corridors that meet affordability and labor requirements.

The City should consider utilizing local workforce policies and requirements to benefit the local area economically and to mitigate greenhouse gas, improve air quality, and reduce transportation impacts.

II. THE CITY SHOULD IMPOSE TRAINING REQUIREMENTS FOR THE PROJECT’S CONSTRUCTION ACTIVITIES TO PREVENT COMMUNITY SPREAD OF COVID-19 AND OTHER INFECTIOUS DISEASES

Construction work has been defined as a Lower to High-risk activity for COVID-19 spread by the Occupational Safety and Health Administration. Recently, several construction sites have been identified as sources of community spread of COVID-19.⁵

⁵ Santa Clara County Public Health (June 12, 2020) COVID-19 CASES AT CONSTRUCTION SITES HIGHLIGHT NEED FOR CONTINUED VIGILANCE IN SECTORS THAT HAVE REOPENED, *available at* <https://www.sccgov.org/sites/covid19/Pages/press-release-06-12-2020-cases-at-construction-sites.aspx>.

Southwest Mountain States Carpenters recommend that the City adopt additional requirements to mitigate public health risks from the Project's construction activities. SWMSRCC requests that the City require safe on-site construction work practices as well as training and certification for any construction workers on the Project Site.

In particular, based upon Southwest Mountain States Carpenters' experience with safe construction site work practices, SWMSRCC recommends that the City require that while construction activities are being conducted at the Project Site:

Construction Site Design:

- The Project Site will be limited to two controlled entry points.
- Entry points will have temperature screening technicians taking temperature readings when the entry point is open.
- The Temperature Screening Site Plan shows details regarding access to the Project Site and Project Site logistics for conducting temperature screening.
- A 48-hour advance notice will be provided to all trades prior to the first day of temperature screening.
- The perimeter fence directly adjacent to the entry points will be clearly marked indicating the appropriate 6-foot social distancing position for when you approach the screening area. Please reference the Apex temperature screening site map for additional details.
- There will be clear signage posted at the project site directing you through temperature screening.
- Provide hand washing stations throughout the construction site.

Testing Procedures:

- The temperature screening being used are non-contact devices.
- Temperature readings will not be recorded.

- Personnel will be screened upon entering the testing center and should only take 1-2 seconds per individual.
- Hard hats, head coverings, sweat, dirt, sunscreen or any other cosmetics must be removed on the forehead before temperature screening.
- Anyone who refuses to submit to a temperature screening or does not answer the health screening questions will be refused access to the Project Site.
- Screening will be performed at both entrances from 5:30 am to 7:30 am.; main gate [ZONE 1] and personnel gate [ZONE 2]
- After 7:30 am only the main gate entrance [ZONE 1] will continue to be used for temperature testing for anybody gaining entry to the project site such as returning personnel, deliveries, and visitors.
- If the digital thermometer displays a temperature reading above 100.0 degrees Fahrenheit, a second reading will be taken to verify an accurate reading.
- If the second reading confirms an elevated temperature, DHS will instruct the individual that he/she will not be allowed to enter the Project Site. DHS will also instruct the individual to promptly notify his/her supervisor and his/her human resources (HR) representative and provide them with a copy of Annex A.

Planning

- Require the development of an Infectious Disease Preparedness and Response Plan that will include basic infection prevention measures (requiring the use of personal protection equipment), policies and procedures for prompt identification and isolation of sick individuals, social distancing (prohibiting gatherings of no more than 10 people including all-hands meetings and all-hands lunches)

communication and training and workplace controls that meet standards that may be promulgated by the Center for Disease Control, Occupational Safety and Health Administration, Cal/OSHA, California Department of Public Health or applicable local public health agencies.⁶

The United Brotherhood of Carpenters and Carpenters International Training Fund has developed COVID-19 Training and Certification to ensure that Carpenter union members and apprentices conduct safe work practices. The City should require that all construction workers undergo COVID-19 Training and Certification before being allowed to conduct construction activities at the Project Site.

Southwest Mountain States Carpenters has also developed a rigorous Infection Control Risk Assessment (“**ICRA**”) training program to ensure it delivers a workforce that understands how to identify and control infection risks by implementing protocols to protect themselves and all others during renovation and construction projects in healthcare environments.⁷

ICRA protocols are intended to contain pathogens, control airflow, and protect patients during the construction, maintenance and renovation of healthcare facilities. ICRA protocols prevent cross contamination, minimizing the risk of secondary infections in patients at hospital facilities.

The City should require the Project to be built using a workforce trained in ICRA protocols.

III. THE CITY SHOULD PREPARE AN ENVIRONMENTAL IMPACT REPORT FOR THE PROJECT

CEQA is a California statute designed to inform decision makers and the public about the potential, significant environmental effects of a project. 14 California Code of

⁶ See also The Center for Construction Research and Training, North America’s Building Trades Unions (April 27 2020) NABTU and CPWR COVID-19 Standards for U.S. Construction Sites, available at https://www.cpwr.com/sites/default/files/NABTU_CPWR_Standards_COVID-19.pdf; Los Angeles County Department of Public Works (2020) Guidelines for Construction Sites During COVID-19 Pandemic, available at https://dpw.lacounty.gov/building-and-safety/docs/pw_guidelines-construction-sites.pdf.

⁷ For details concerning Southwest Carpenters’s ICRA training program, see <https://icrahealthcare.com/>.

Regulations (“**CEQA Guidelines**”) § 15002(a)(1).⁸ At its core, “[i]ts purpose is to inform the public and its responsible officials of the environmental consequences of their decisions *before* they are made.” *Citizens of Goleta Valley v. Board of Supervisors* (1990) 52 Cal. 3d 553, 564.

To achieve this purpose, CEQA mandates preparation of an Environmental Impact Report (“**EIR**”) for projects so that the foreseeable impacts of pursuing the project can be understood and weighed. *Communities for a Better Environment v. Richmond* (2010) 184 Cal. App. 4th 70, 80. The EIR requirement “is the heart of CEQA.” CEQA Guidelines, § 15003(a).

A strong presumption in favor of requiring preparation of an EIR is built into CEQA. This presumption is reflected in what is known as the "fair argument" standard, under which an agency must prepare an EIR whenever substantial evidence in the record supports a fair argument that a project may have a significant effect on the environment. *Quail Botanical Gardens Found., Inc. v. City of Encinitas* (1994) 29 Cal. App. 4th 1597, 1602; *Friends of "B" St. v. City of Hayward* (1980) 106 Cal. 3d 988, 1002.

The fair argument test stems from the statutory mandate that an EIR be prepared for any project that "may have a significant effect on the environment." Public Resources Code (“**PRC**”) § 21151; *No Oil, Inc. v. City of Los Angeles* (1974) 13 Cal. App. 3d 68, 75; *Jensen v. City of Santa Rosa* (2018) 23 Cal. App. 5th 877, 884. Under this test, if a proposed project is not exempt and may cause a significant effect on the environment, the lead agency must prepare an EIR. PRC §§ 21100(a), 21151; CEQA Guidelines § 15064(a)(1), (f)(1). An EIR may be dispensed with only if the lead agency finds no substantial evidence in the initial study or elsewhere in the record that the project may have a significant effect on the environment. *Parker Shattuck Neighbors v. Berkeley City Council* (2013) 222 Cal. App. 4th 768, 785. In such a situation, the agency must adopt a negative declaration. PRC § 21080(c)(1); CEQA Guidelines §§ 15063(b)(2), 15064(f)(3).

⁸ The CEQA Guidelines, codified in Title 14 of the California Code of Regulations, section 15000 *et seq.*, are regulatory guidelines promulgated by the state Natural Resources Agency for the implementation of CEQA. (Cal. Pub. Res. Code § 21083.) The CEQA Guidelines are given “great weight in interpreting CEQA except when . . . clearly unauthorized or erroneous.” *Center for Biological Diversity v. Department of Fish & Wildlife* (2015) 62 Cal. 4th 204, 217.

"Significant effect upon the environment" is defined as "a substantial or potentially substantial adverse change in the environment." PRC § 21068; CEQA Guidelines § 15382. A project "may" have a significant effect on the environment if there is a "reasonable probability" that it will result in a significant impact. *No Oil, Inc. v. City of Los Angeles*, 13 Cal. 3d at 83 fn. 16; *Sundstrom v. County of Mendocino* (1988) 202 Cal. App. 3d 296, 309. If any aspect of the project may result in a significant impact on the environment, an EIR must be prepared even if the overall effect of the project is beneficial. CEQA Guidelines § 15063(b)(1). See *County Sanitation Dist. No. 2 v. County of Kern* (2005) 127 Cal. App. 4th 1544, 1580.

This standard sets a "low threshold" for preparation of an EIR. *Consolidated Irrig. Dist. v. City of Selma* (2012) 204 Cal. App. 4th 187, 207; *Nelson v. County of Kern* (2010) 190 Cal. App. 4th 252; *Pocket Protectors v. City of Sacramento* (2004) 124 Cal. App. 4th 903, 928; *Bowman v. City of Berkeley* (2004) 122 Cal. App. 4th 572, 580; *Citizen Action to Serve All Students v. Thornley* (1990) 222 Cal. App. 3d 748, 754; *Sundstrom v. County of Mendocino* (1988) 202 Cal. App. 3d 296, 310. If substantial evidence in the record supports a fair argument that the project may have a significant environmental effect, the lead agency must prepare an EIR even if other substantial evidence before it indicates the project will have no significant effect. See *Jensen v. City of Santa Rosa* (2018) 23 Cal. App. 5th 877, 886; *Clews Land & Livestock v. City of San Diego* (2017) 19 Cal. App. 5th 161, 183; *Stanislaus Audubon Soc'y, Inc. v. County of Stanislaus* (1995) 33 Cal. App. 4th 144, 150; *Brentwood Ass'n for No Drilling, Inc. v. City of Los Angeles* (1982) 134 Cal. App. 3d 491; *Friends of "B" St. v. City of Hayward* (1980) 106 Cal. App. 3d 988; CEQA Guidelines § 15064(f)(1).

As there is a fair argument that the Project may cause significant environmental impacts, as explained below, the low threshold is met and the City should prepare an EIR for the Project.

IV. THE CITY SHOULD DETERMINE THAT THE PROJECT DOES NOT QUALIFY FOR THE CLASS 32 CEQA EXEMPTION

CEQA exemptions must be construed narrowly. See *County of Amador v. El Dorado County Water Agency* (1999) 76 Cal.App.4th 931, 966. With regard to Class 32 exemptions for in-fill development projects, the project must meet all of the conditions identified in CEQA Guidelines section 15332, as follows:

- (a) The project is consistent with the applicable general plan designation and all applicable general plan policies as well as with applicable zoning designation and regulations;
- (b) The proposed development occurs within city limits on a project site of no more than five acres substantially surrounded by urban uses;
- (c) The project site has no value, as habitat for endangered, rare or threatened species;
- (d) Approval of the project would not result in any significant effects relating to traffic, noise, air quality, or water quality; and
- (e) The site can be adequately served by all required utilities and public services.

Moreover, categorical exemptions are not absolute. Even if a project fits into a categorical exemption class, the agency must consider whether a codified exception to exemption applies. Guidelines § 15300.2. A project falling within a categorical exemption may require environmental review if the project is subject to exceptions-to-the-exemptions listed under CEQA Guidelines § 15300.2, which include projects involving: (a) locations involving environmental resources of hazardous or critical concern; (b) significant cumulative impact of successive projects of the same type in the same place; (c) reasonable possibility of significant environmental effect due to unusual circumstances; (d) damage to scenic resources on State scenic highways; (e) locations listed as a hazardous waste site; or (f) substantial adverse changes to a historical resource.

Here, the Project fails to comply with all the required conditions. Therefore, the Project does not qualify for the Class 32 CEQA exemption.

A. The Project Is Inconsistent with the General Plan

Each California city and county must adopt a comprehensive, long-term general plan governing development. *Napa Citizens for Honest Gov. v. Napa County Bd. of Supervisors* (2001) 91 Cal.App.4th 342, 352, citing Gov. Code §§ 65030, 65300. The general plan sits at the top of the land use planning hierarchy, and serves as a “constitution” or “charter” for all future development. *DeVita v. County of Napa* (1995) 9 Cal.4th 763, 773; *Leshner Communications, Inc. v. City of Walnut Creek* (1990) 52 Cal.3d 531, 540.

General plan consistency is “the linchpin of California’s land use and development laws; it is the principle which infused the concept of planned growth with the force of law.” *Debottari v. Norco City Council* (1985) 171 Cal.App.3d 1204, 1213. It is well established that development projects may not be approved if they interfere with, or frustrate, the general plan’s policies and objectives. See *Napa Citizens*, 91 Cal.App.4th at 378-79; see also *Lesher*, 52 Cal.3d at 544.

Here, the Project requests numerous departures from the ordinary limits permitted by the General Plan and zoning designations, including but not limited to a density bonus, floor area ratio increase, side yard reduction, removal of the 36 feet height limitation “D”, at least three zoning administrator’s reviews (ZA), and one zoning injunction (ZI). (See, **Exhibit D** [LADBS Permit Info, as of 4/25/2023].) Specifically, the Project proposes construction of a 7-story, 87 ft tall, 137,640 sf mixed-use building, containing 151 residential units, 3,690 sf of commercial space, 20,565 sf of open space, and 87 parking spaces.

Further, per the City’s records, the Applicant has attempted to address the City’s corrections several times in 2022, but failed to clear even a single one to date. (*Id.*)

Also, per the 9/20/2022 EPS Intake Form Submission (produced by the City in response to our PRA requests), the Applicant not only seeks a density bonus, but also a conditional use permit to exceed the density bonus increase otherwise allowed by the state density bonus law.

In addition, the Project is located in the Hollywood Community Plan Area, which is still subject to the zoning injunction, including injunction against the removal of “D” height and other density/intensity limitations the City’s 2012 Hollywood Community Plan Update sought, but the Court set it aside; the new Hollywood Community Plan Update is not final and applicable.⁹ The Community plan is part of the City’s General Plan, and the Project must comply with its requirements, but manifestly does not.

Moreover, given the number of deviations the Project Applicant seeks, it far exceeds the number of incentives and concessions under the State Density Bonus Law.

Thus, given that the incentives and conditional use permit have not yet been approved (and potentially would be impossible to approve) and they far exceed the number of allowable density increase or incentives under the state law or zoning regulations,

⁹ See April 2, 2014 ZI No. 2433 [Revised Hollywood Community Plan Injunction], <http://zimas.lacity.org/documents/zoneinfo/ZI2433.pdf>

there is a colorful argument that the Project is inconsistent with the General Plan and all applicable zoning regulations, rendering it ineligible for a Class 32 CEQA exemption.¹⁰

B. The Project May Have Significant Environmental Effects

CEQA exemptions are reserved for projects without potential to have significant environmental effects. See *Salmon Protection & Watershed Network v. County of Marin* (2004) 125 Cal.App.4th 1098, 1107 [“If a project may have a significant effect on the environment, CEQA review must occur”]. The Project at hand has the potential to cause a number of significant environmental effects, which the proposed findings for the Project fail to address whatsoever let alone attempt to analyze.¹¹

The very nature of the Project, i.e. constructing a 7-story mixed-use residential building in place of a retail store with less intensity (Goodwill), creates potentially significant traffic, air quality, and noise issues stemming from the sheer increase in density and intensity of land use on the Project site. Coupled with the fact that the construction of the Project may involve road closures, street detours, and loud construction equipment, the Project has the potential to cause significant traffic, air quality, and noise impacts.

Further, these impacts may be more significant since, per the building permit information (see, Exhibit D), the Project seeks construction within easement, adjacent to public way, next to power lines, and encroaches in public way. To the extent the Project’s staging of heavy construction equipment may foreseeably occur in the public easement area and on top of utility connections, the Project may also have a significant impact on public utilities, traffic and circulation. This may well translate into more air quality, greenhouse gas emissions, noise and other traffic-related impacts.

¹⁰ See LA Department of Building & Safety Project Permit information [noting that the Density Bonus has not yet been cleared], available at <https://www.ladbsservices2.lacity.org/OnlineServices/PermitReport/PCISPermitDetail?id1=22010&id2=10000&id3=05021>.

¹¹ See Project Proposed Findings, available at <https://planning.lacity.org/pdiscaseinfo/document/NDEyNjE0/532f8e86-06a9-44b1-8001-06cd07316c90/esubmit>.

Without any Project-specific analysis quantifying the Project’s anticipated traffic, air quality, and noise impacts, the assertion that the Project will not have any significant impacts is merely speculative. Thus, the Class 32 CEQA exemption is inapplicable.

C. There Is No Evidence that The Project Site Can Be Adequately Served by All Required Utilities and Public Services.

Under CEQA Guidelines section 15332(d), there must be evidence that the Project site can be adequately served by all required utilities and public services. Here, there is no evidence that the Project site is equipped to handle the additional energy, water, and waste consumption of 151 new residential units in place of a retail store. In fact, the evidence points to the opposite conclusion since the sewer availability and waste drainage subsections of the Project permit have not yet been cleared by the Bureau of Engineering.¹² Accordingly, the Project must not qualify for the Class 32 exemption.

D. The Project May Be Subject to Exceptions to the Class 32 Exemption

Pursuant to CEQA Guidelines section 15300.2(c), “a categorical exemption shall not be used for an activity where there is a reasonable possibility that the activity will have a significant effect on the environment due to unusual circumstances.” Here, given the Project’s plan to demolish several former retail stores, excavate more than 5 feet deep, and construct a building over 36 feet tall, the Project presents unusual circumstances, with the possibility to result in significant environmental effects.¹³

Similarly, pursuant to CEQA Guidelines section 15300.2(b), all exemptions “are inapplicable when the cumulative impact of successive projects of the same type in the same place, over time is significant.” Here, there are several similar mixed-use building projects being proposed or constructed directly near the Project which may result in cumulative impacts. For example, there is an 8-story office and retail building proposed at 1235 N. Vine Street¹⁴; a 3-story office and retail complex proposed at 1200 N. Cahuenga Blvd.¹⁵; and a recently developed 7-story mixed-use residential

¹² See LA Department of Building & Safety Project Permit information, *available at* <https://www.ladbsservices2.lacity.org/OnlineServices/PermitReport/PCISPermitDetail?id1=22010&id2=10000&id3=05021>.

¹³ *Id.*

¹⁴ Eight-Story Office Building Planned Near Fountain & Vine (Mar. 2020), *available at* <https://la.urbanize.city/post/eight-story-office-building-planned-near-fountain-vine>

¹⁵ 75,000sf office complex planned for Cahuenga Boulevard (Dec. 2021), *available at* <https://la.urbanize.city/post/75000sf-office-complex-planned-cahuenga-boulevard>.

building at 1311 N. Cahuenga Blvd.¹⁶, all of which are less than 0.5 miles away from the Project.

The Project, along with these and other nearby projects, may collectively contribute to potentially significant cumulative impacts on air quality, noise, and traffic congestion in the neighborhood.

For these reasons too, the Class 23 CEQA exemption is not applicable since the exceptions under CEQA Guidelines section 15300.2 apply.¹⁷

V. CONCLUSION

In sum, SMSWRCC requests that the City require a local workforce, that the City impose training requirements for the Project's construction activities to prevent community spread of COVID-19 and other infectious diseases, and that the City prepare an EIR for the Project and determine that the Project does not qualify for a Class 32 CEQA exemption for the aforementioned concerns. If the City has any questions, feel free to contact my Office.

Sincerely,



Talia Nimmer

Attorneys for Southwest Mountain States Regional Council of Carpenters

Attached:

Exhibit A: March 8, 2021 SWAPE Letter to Mitchell M. Tsai re Local Hire Requirements and Considerations for Greenhouse Gas Modeling;

Exhibit B: Air Quality and GHG Expert Paul Rosenfeld CV;

Exhibit C: Air Quality and GHG Expert Matt Hagemann CV; and

¹⁶ The Rise,

https://risehollywood.com/?campaignid=10679610387&adgroupid=104161672014&creative=452225925322&matchtype=p&network=g&device=c&keyword=the%20rise%20hollywood&gclid=CjwKCAjw_ihBhADEiwAXEazJgLbYKq1HvVREvWxOJ1Xw_T6yK21i38a_NBjT0tAKRoO3e2_o6MS3RoCPzQQAvD_BwE.

¹⁷ Per the Building Permits Info (Exhibit D), the Project's activities will occur next to trees in parkway. As such, depending on the type and size of trees and whether they are protected or not, the Project may have an impact on biological resources and thereby make the Class 32 exemption improper or otherwise trigger an unusual circumstances exception.

Exhibit D: LADBS Permit Information, as of 4/25/2023.

EXHIBIT A



Technical Consultation, Data Analysis and
Litigation Support for the Environment

2656 29th Street, Suite 201
Santa Monica, CA 90405

Matt Hagemann, P.G, C.Hg.
(949) 887-9013
mhagemann@swape.com

Paul E. Rosenfeld, PhD
(310) 795-2335
prosenfeld@swape.com

March 8, 2021

Mitchell M. Tsai
155 South El Molino, Suite 104
Pasadena, CA 91101

Subject: Local Hire Requirements and Considerations for Greenhouse Gas Modeling

Dear Mr. Tsai,

Soil Water Air Protection Enterprise (“SWAPE”) is pleased to provide the following draft technical report explaining the significance of worker trips required for construction of land use development projects with respect to the estimation of greenhouse gas (“GHG”) emissions. The report will also discuss the potential for local hire requirements to reduce the length of worker trips, and consequently, reduced or mitigate the potential GHG impacts.

Worker Trips and Greenhouse Gas Calculations

The California Emissions Estimator Model (“CalEEMod”) is a “statewide land use emissions computer model designed to provide a uniform platform for government agencies, land use planners, and environmental professionals to quantify potential criteria pollutant and greenhouse gas (GHG) emissions associated with both construction and operations from a variety of land use projects.”¹ CalEEMod quantifies construction-related emissions associated with land use projects resulting from off-road construction equipment; on-road mobile equipment associated with workers, vendors, and hauling; fugitive dust associated with grading, demolition, truck loading, and on-road vehicles traveling along paved and unpaved roads; and architectural coating activities; and paving.²

The number, length, and vehicle class of worker trips are utilized by CalEEMod to calculate emissions associated with the on-road vehicle trips required to transport workers to and from the Project site during construction.³

¹ “California Emissions Estimator Model.” CAPCOA, 2017, available at: <http://www.aqmd.gov/caleemod/home>.

² “California Emissions Estimator Model.” CAPCOA, 2017, available at: <http://www.aqmd.gov/caleemod/home>.

³ “CalEEMod User’s Guide.” CAPCOA, November 2017, available at: http://www.aqmd.gov/docs/default-source/caleemod/01_user-39-s-guide2016-3-2_15november2017.pdf?sfvrsn=4, p. 34.

Specifically, the number and length of vehicle trips is utilized to estimate the vehicle miles travelled (“VMT”) associated with construction. Then, utilizing vehicle-class specific EMFAC 2014 emission factors, CalEEMod calculates the vehicle exhaust, evaporative, and dust emissions resulting from construction-related VMT, including personal vehicles for worker commuting.⁴

Specifically, in order to calculate VMT, CalEEMod multiplies the average daily trip rate by the average overall trip length (see excerpt below):

$$\text{“VMT}_d = \Sigma(\text{Average Daily Trip Rate}_i * \text{Average Overall Trip Length}_i)_n$$

Where:

n = Number of land uses being modeled.”⁵

Furthermore, to calculate the on-road emissions associated with worker trips, CalEEMod utilizes the following equation (see excerpt below):

$$\text{“Emissions}_{\text{pollutant}} = \text{VMT} * \text{EF}_{\text{running,pollutant}}$$

Where:

$\text{Emissions}_{\text{pollutant}}$ = emissions from vehicle running for each pollutant

VMT = vehicle miles traveled

$\text{EF}_{\text{running,pollutant}}$ = emission factor for running emissions.”⁶

Thus, there is a direct relationship between trip length and VMT, as well as a direct relationship between VMT and vehicle running emissions. In other words, when the trip length is increased, the VMT and vehicle running emissions increase as a result. Thus, vehicle running emissions can be reduced by decreasing the average overall trip length, by way of a local hire requirement or otherwise.

Default Worker Trip Parameters and Potential Local Hire Requirements

As previously discussed, the number, length, and vehicle class of worker trips are utilized by CalEEMod to calculate emissions associated with the on-road vehicle trips required to transport workers to and from the Project site during construction.⁷ In order to understand how local hire requirements and associated worker trip length reductions impact GHG emissions calculations, it is important to consider the CalEEMod default worker trip parameters. CalEEMod provides recommended default values based on site-specific information, such as land use type, meteorological data, total lot acreage, project type and typical equipment associated with project type. If more specific project information is known, the user can change the default values and input project-specific values, but the California Environmental Quality Act (“CEQA”) requires that such changes be justified by substantial evidence.⁸ The default number of construction-related worker trips is calculated by multiplying the

⁴ “Appendix A Calculation Details for CalEEMod.” CAPCOA, October 2017, available at: http://www.aqmd.gov/docs/default-source/caleemod/02_appendix-a2016-3-2.pdf?sfvrsn=6, p. 14-15.

⁵ “Appendix A Calculation Details for CalEEMod.” CAPCOA, October 2017, available at: http://www.aqmd.gov/docs/default-source/caleemod/02_appendix-a2016-3-2.pdf?sfvrsn=6, p. 23.

⁶ “Appendix A Calculation Details for CalEEMod.” CAPCOA, October 2017, available at: http://www.aqmd.gov/docs/default-source/caleemod/02_appendix-a2016-3-2.pdf?sfvrsn=6, p. 15.

⁷ “CalEEMod User’s Guide.” CAPCOA, November 2017, available at: http://www.aqmd.gov/docs/default-source/caleemod/01_user-39-s-guide2016-3-2_15november2017.pdf?sfvrsn=4, p. 34.

⁸ CalEEMod User Guide, available at: <http://www.caleemod.com/>, p. 1, 9.

number of pieces of equipment for all phases by 1.25, with the exception of worker trips required for the building construction and architectural coating phases.⁹ Furthermore, the worker trip vehicle class is a 50/25/25 percent mix of light duty autos, light duty truck class 1 and light duty truck class 2, respectively.”¹⁰ Finally, the default worker trip length is consistent with the length of the operational home-to-work vehicle trips.¹¹ The operational home-to-work vehicle trip lengths are:

“[B]ased on the *location* and *urbanization* selected on the project characteristic screen. These values were *supplied by the air districts or use a default average for the state*. Each district (or county) also assigns trip lengths for urban and rural settings” (emphasis added).¹²

Thus, the default worker trip length is based on the location and urbanization level selected by the User when modeling emissions. The below table shows the CalEEMod default rural and urban worker trip lengths by air basin (see excerpt below and Attachment A).¹³

Worker Trip Length by Air Basin		
Air Basin	Rural (miles)	Urban (miles)
Great Basin Valleys	16.8	10.8
Lake County	16.8	10.8
Lake Tahoe	16.8	10.8
Mojave Desert	16.8	10.8
Mountain Counties	16.8	10.8
North Central Coast	17.1	12.3
North Coast	16.8	10.8
Northeast Plateau	16.8	10.8
Sacramento Valley	16.8	10.8
Salton Sea	14.6	11
San Diego	16.8	10.8
San Francisco Bay Area	10.8	10.8
San Joaquin Valley	16.8	10.8
South Central Coast	16.8	10.8
South Coast	19.8	14.7
Average	16.47	11.17
Minimum	10.80	10.80
Maximum	19.80	14.70
Range	9.00	3.90

⁹ “CalEEMod User’s Guide.” CAPCOA, November 2017, available at: http://www.aqmd.gov/docs/default-source/caleemod/01_user-39-s-guide2016-3-2_15november2017.pdf?sfvrsn=4, p. 34.

¹⁰ “Appendix A Calculation Details for CalEEMod.” CAPCOA, October 2017, available at: http://www.aqmd.gov/docs/default-source/caleemod/02_appendix-a2016-3-2.pdf?sfvrsn=6, p. 15.

¹¹ “Appendix A Calculation Details for CalEEMod.” CAPCOA, October 2017, available at: http://www.aqmd.gov/docs/default-source/caleemod/02_appendix-a2016-3-2.pdf?sfvrsn=6, p. 14.

¹² “Appendix A Calculation Details for CalEEMod.” CAPCOA, October 2017, available at: http://www.aqmd.gov/docs/default-source/caleemod/02_appendix-a2016-3-2.pdf?sfvrsn=6, p. 21.

¹³ “Appendix D Default Data Tables.” CAPCOA, October 2017, available at: http://www.aqmd.gov/docs/default-source/caleemod/05_appendix-d2016-3-2.pdf?sfvrsn=4, p. D-84 – D-86.

As demonstrated above, default rural worker trip lengths for air basins in California vary from 10.8- to 19.8- miles, with an average of 16.47 miles. Furthermore, default urban worker trip lengths vary from 10.8- to 14.7- miles, with an average of 11.17 miles. Thus, while default worker trip lengths vary by location, default urban worker trip lengths tend to be shorter in length. Based on these trends evident in the CalEEMod default worker trip lengths, we can reasonably assume that the efficacy of a local hire requirement is especially dependent upon the urbanization of the project site, as well as the project location.

Practical Application of a Local Hire Requirement and Associated Impact

To provide an example of the potential impact of a local hire provision on construction-related GHG emissions, we estimated the significance of a local hire provision for the Village South Specific Plan (“Project”) located in the City of Claremont (“City”). The Project proposed to construct 1,000 residential units, 100,000-SF of retail space, 45,000-SF of office space, as well as a 50-room hotel, on the 24-acre site. The Project location is classified as Urban and lies within the Los Angeles-South Coast County. As a result, the Project has a default worker trip length of 14.7 miles.¹⁴ In an effort to evaluate the potential for a local hire provision to reduce the Project’s construction-related GHG emissions, we prepared an updated model, reducing all worker trip lengths to 10 miles (see Attachment B). Our analysis estimates that if a local hire provision with a 10-mile radius were to be implemented, the GHG emissions associated with Project construction would decrease by approximately 17% (see table below and Attachment C).

Local Hire Provision Net Change	
Without Local Hire Provision	
Total Construction GHG Emissions (MT CO ₂ e)	3,623
Amortized Construction GHG Emissions (MT CO ₂ e/year)	120.77
With Local Hire Provision	
Total Construction GHG Emissions (MT CO ₂ e)	3,024
Amortized Construction GHG Emissions (MT CO ₂ e/year)	100.80
% Decrease in Construction-related GHG Emissions	17%

As demonstrated above, by implementing a local hire provision requiring 10 mile worker trip lengths, the Project could reduce potential GHG emissions associated with construction worker trips. More broadly, any local hire requirement that results in a decreased worker trip length from the default value has the potential to result in a reduction of construction-related GHG emissions, though the significance of the reduction would vary based on the location and urbanization level of the project site.

This serves as an example of the potential impacts of local hire requirements on estimated project-level GHG emissions, though it does not indicate that local hire requirements would result in reduced construction-related GHG emission for all projects. As previously described, the significance of a local hire requirement depends on the worker trip length enforced and the default worker trip length for the project’s urbanization level and location.

¹⁴ “Appendix D Default Data Tables.” CAPCOA, October 2017, available at: http://www.aqmd.gov/docs/default-source/caleemod/05_appendix-d2016-3-2.pdf?sfvrsn=4, p. D-85.

Disclaimer

SWAPE has received limited discovery. Additional information may become available in the future; thus, we retain the right to revise or amend this report when additional information becomes available. Our professional services have been performed using that degree of care and skill ordinarily exercised, under similar circumstances, by reputable environmental consultants practicing in this or similar localities at the time of service. No other warranty, expressed or implied, is made as to the scope of work, work methodologies and protocols, site conditions, analytical testing results, and findings presented. This report reflects efforts which were limited to information that was reasonably accessible at the time of the work, and may contain informational gaps, inconsistencies, or otherwise be incomplete due to the unavailability or uncertainty of information obtained or provided by third parties.

Sincerely,

A handwritten signature in blue ink that reads "Matt Hagemann".

Matt Hagemann, P.G., C.Hg.

A handwritten signature in blue ink that reads "Paul Rosenfeld".

Paul E. Rosenfeld, Ph.D.

Attachment A

Location Type	Location Name	Rural H-W (miles)	Urban H-W (miles)
Air Basin	Great Basin	16.8	10.8
Air Basin	Lake County	16.8	10.8
Air Basin	Lake Tahoe	16.8	10.8
Air Basin	Mojave Desert	16.8	10.8
Air Basin	Mountain	16.8	10.8
Air Basin	North Central	17.1	12.3
Air Basin	North Coast	16.8	10.8
Air Basin	Northeast	16.8	10.8
Air Basin	Sacramento	16.8	10.8
Air Basin	Salton Sea	14.6	11
Air Basin	San Diego	16.8	10.8
Air Basin	San Francisco	10.8	10.8
Air Basin	San Joaquin	16.8	10.8
Air Basin	South Central	16.8	10.8
Air Basin	South Coast	19.8	14.7
Air District	Amador County	16.8	10.8
Air District	Antelope Valley	16.8	10.8
Air District	Bay Area AQMD	10.8	10.8
Air District	Butte County	12.54	12.54
Air District	Calaveras	16.8	10.8
Air District	Colusa County	16.8	10.8
Air District	El Dorado	16.8	10.8
Air District	Feather River	16.8	10.8
Air District	Glenn County	16.8	10.8
Air District	Great Basin	16.8	10.8
Air District	Imperial County	10.2	7.3
Air District	Kern County	16.8	10.8
Air District	Lake County	16.8	10.8
Air District	Lassen County	16.8	10.8
Air District	Mariposa	16.8	10.8
Air District	Mendocino	16.8	10.8
Air District	Modoc County	16.8	10.8
Air District	Mojave Desert	16.8	10.8
Air District	Monterey Bay	16.8	10.8
Air District	North Coast	16.8	10.8
Air District	Northern Sierra	16.8	10.8
Air District	Northern	16.8	10.8
Air District	Placer County	16.8	10.8
Air District	Sacramento	15	10

Air District	San Diego	16.8	10.8
Air District	San Joaquin	16.8	10.8
Air District	San Luis Obispo	13	13
Air District	Santa Barbara	8.3	8.3
Air District	Shasta County	16.8	10.8
Air District	Siskiyou County	16.8	10.8
Air District	South Coast	19.8	14.7
Air District	Tehama County	16.8	10.8
Air District	Tuolumne	16.8	10.8
Air District	Ventura County	16.8	10.8
Air District	Yolo/Solano	15	10
County	Alameda	10.8	10.8
County	Alpine	16.8	10.8
County	Amador	16.8	10.8
County	Butte	12.54	12.54
County	Calaveras	16.8	10.8
County	Colusa	16.8	10.8
County	Contra Costa	10.8	10.8
County	Del Norte	16.8	10.8
County	El Dorado-Lake	16.8	10.8
County	El Dorado-	16.8	10.8
County	Fresno	16.8	10.8
County	Glenn	16.8	10.8
County	Humboldt	16.8	10.8
County	Imperial	10.2	7.3
County	Inyo	16.8	10.8
County	Kern-Mojave	16.8	10.8
County	Kern-San	16.8	10.8
County	Kings	16.8	10.8
County	Lake	16.8	10.8
County	Lassen	16.8	10.8
County	Los Angeles-	16.8	10.8
County	Los Angeles-	19.8	14.7
County	Madera	16.8	10.8
County	Marin	10.8	10.8
County	Mariposa	16.8	10.8
County	Mendocino-	16.8	10.8
County	Mendocino-	16.8	10.8
County	Mendocino-	16.8	10.8
County	Mendocino-	16.8	10.8
County	Merced	16.8	10.8
County	Modoc	16.8	10.8
County	Mono	16.8	10.8
County	Monterey	16.8	10.8
County	Napa	10.8	10.8

County	Nevada	16.8	10.8
County	Orange	19.8	14.7
County	Placer-Lake	16.8	10.8
County	Placer-Mountain	16.8	10.8
County	Placer-	16.8	10.8
County	Plumas	16.8	10.8
County	Riverside-	16.8	10.8
County	Riverside-	19.8	14.7
County	Riverside-Salton	14.6	11
County	Riverside-South	19.8	14.7
County	Sacramento	15	10
County	San Benito	16.8	10.8
County	San Bernardino-	16.8	10.8
County	San Bernardino-	19.8	14.7
County	San Diego	16.8	10.8
County	San Francisco	10.8	10.8
County	San Joaquin	16.8	10.8
County	San Luis Obispo	13	13
County	San Mateo	10.8	10.8
County	Santa Barbara-	8.3	8.3
County	Santa Barbara-	8.3	8.3
County	Santa Clara	10.8	10.8
County	Santa Cruz	16.8	10.8
County	Shasta	16.8	10.8
County	Sierra	16.8	10.8
County	Siskiyou	16.8	10.8
County	Solano-	15	10
County	Solano-San	16.8	10.8
County	Sonoma-North	16.8	10.8
County	Sonoma-San	10.8	10.8
County	Stanislaus	16.8	10.8
County	Sutter	16.8	10.8
County	Tehama	16.8	10.8
County	Trinity	16.8	10.8
County	Tulare	16.8	10.8
County	Tuolumne	16.8	10.8
County	Ventura	16.8	10.8
County	Yolo	15	10
County	Yuba	16.8	10.8
Statewide	Statewide	16.8	10.8

Worker Trip Length by Air Basin		
Air Basin	Rural (miles)	Urban (miles)
Great Basin Valleys	16.8	10.8
Lake County	16.8	10.8
Lake Tahoe	16.8	10.8
Mojave Desert	16.8	10.8
Mountain Counties	16.8	10.8
North Central Coast	17.1	12.3
North Coast	16.8	10.8
Northeast Plateau	16.8	10.8
Sacramento Valley	16.8	10.8
Salton Sea	14.6	11
San Diego	16.8	10.8
San Francisco Bay Area	10.8	10.8
San Joaquin Valley	16.8	10.8
South Central Coast	16.8	10.8
South Coast	19.8	14.7
Average	16.47	11.17
Minimum	10.80	10.80
Maximum	19.80	14.70
Range	9.00	3.90

Village South Specific Plan (Proposed) - Los Angeles-South Coast County, Annual

Village South Specific Plan (Proposed)
Los Angeles-South Coast County, Annual

1.0 Project Characteristics**1.1 Land Usage**

Land Uses	Size	Metric	Lot Acreage	Floor Surface Area	Population
General Office Building	45.00	1000sqft	1.03	45,000.00	0
High Turnover (Sit Down Restaurant)	36.00	1000sqft	0.83	36,000.00	0
Hotel	50.00	Room	1.67	72,600.00	0
Quality Restaurant	8.00	1000sqft	0.18	8,000.00	0
Apartments Low Rise	25.00	Dwelling Unit	1.56	25,000.00	72
Apartments Mid Rise	975.00	Dwelling Unit	25.66	975,000.00	2789
Regional Shopping Center	56.00	1000sqft	1.29	56,000.00	0

1.2 Other Project Characteristics

Urbanization	Urban	Wind Speed (m/s)	2.2	Precipitation Freq (Days)	33
Climate Zone	9			Operational Year	2028
Utility Company	Southern California Edison				
CO2 Intensity (lb/MWhr)	702.44	CH4 Intensity (lb/MWhr)	0.029	N2O Intensity (lb/MWhr)	0.006

1.3 User Entered Comments & Non-Default Data

Village South Specific Plan (Proposed) - Los Angeles-South Coast County, Annual

Project Characteristics - Consistent with the DEIR's model.

Land Use - See SWAPE comment regarding residential and retail land uses.

Construction Phase - See SWAPE comment regarding individual construction phase lengths.

Demolition - Consistent with the DEIR's model. See SWAPE comment regarding demolition.

Vehicle Trips - Saturday trips consistent with the DEIR's model. See SWAPE comment regarding weekday and Sunday trips.

Woodstoves - Woodstoves and wood-burning fireplaces consistent with the DEIR's model. See SWAPE comment regarding gas fireplaces.

Energy Use -

Construction Off-road Equipment Mitigation - See SWAPE comment on construction-related mitigation.

Area Mitigation - See SWAPE comment regarding operational mitigation measures.

Water Mitigation - See SWAPE comment regarding operational mitigation measures.

Table Name	Column Name	Default Value	New Value
tblFireplaces	FireplaceWoodMass	1,019.20	0.00
tblFireplaces	FireplaceWoodMass	1,019.20	0.00
tblFireplaces	NumberWood	1.25	0.00
tblFireplaces	NumberWood	48.75	0.00
tblVehicleTrips	ST_TR	7.16	6.17
tblVehicleTrips	ST_TR	6.39	3.87
tblVehicleTrips	ST_TR	2.46	1.39
tblVehicleTrips	ST_TR	158.37	79.82
tblVehicleTrips	ST_TR	8.19	3.75
tblVehicleTrips	ST_TR	94.36	63.99
tblVehicleTrips	ST_TR	49.97	10.74
tblVehicleTrips	SU_TR	6.07	6.16
tblVehicleTrips	SU_TR	5.86	4.18
tblVehicleTrips	SU_TR	1.05	0.69
tblVehicleTrips	SU_TR	131.84	78.27

Village South Specific Plan (Proposed) - Los Angeles-South Coast County, Annual

tblVehicleTrips	SU_TR	5.95	3.20
tblVehicleTrips	SU_TR	72.16	57.65
tblVehicleTrips	SU_TR	25.24	6.39
tblVehicleTrips	WD_TR	6.59	5.83
tblVehicleTrips	WD_TR	6.65	4.13
tblVehicleTrips	WD_TR	11.03	6.41
tblVehicleTrips	WD_TR	127.15	65.80
tblVehicleTrips	WD_TR	8.17	3.84
tblVehicleTrips	WD_TR	89.95	62.64
tblVehicleTrips	WD_TR	42.70	9.43
tblWoodstoves	NumberCatalytic	1.25	0.00
tblWoodstoves	NumberCatalytic	48.75	0.00
tblWoodstoves	NumberNoncatalytic	1.25	0.00
tblWoodstoves	NumberNoncatalytic	48.75	0.00
tblWoodstoves	WoodstoveDayYear	25.00	0.00
tblWoodstoves	WoodstoveDayYear	25.00	0.00
tblWoodstoves	WoodstoveWoodMass	999.60	0.00
tblWoodstoves	WoodstoveWoodMass	999.60	0.00

2.0 Emissions Summary

Village South Specific Plan (Proposed) - Los Angeles-South Coast County, Annual

2.1 Overall Construction

Unmitigated Construction

	ROG	NOx	CO	SO2	Fugitive PM10	Exhaust PM10	PM10 Total	Fugitive PM2.5	Exhaust PM2.5	PM2.5 Total	Bio- CO2	NBio- CO2	Total CO2	CH4	N2O	CO2e
Year	tons/yr										MT/yr					
2021	0.1713	1.8242	1.1662	2.4000e-003	0.4169	0.0817	0.4986	0.1795	0.0754	0.2549	0.0000	213.1969	213.1969	0.0601	0.0000	214.6993
2022	0.6904	4.1142	6.1625	0.0189	1.3058	0.1201	1.4259	0.3460	0.1128	0.4588	0.0000	1,721.6826	1,721.6826	0.1294	0.0000	1,724.9187
2023	0.6148	3.3649	5.6747	0.0178	1.1963	0.0996	1.2959	0.3203	0.0935	0.4138	0.0000	1,627.5295	1,627.5295	0.1185	0.0000	1,630.4925
2024	4.1619	0.1335	0.2810	5.9000e-004	0.0325	6.4700e-003	0.0390	8.6300e-003	6.0400e-003	0.0147	0.0000	52.9078	52.9078	8.0200e-003	0.0000	53.1082
Maximum	4.1619	4.1142	6.1625	0.0189	1.3058	0.1201	1.4259	0.3460	0.1128	0.4588	0.0000	1,721.6826	1,721.6826	0.1294	0.0000	1,724.9187

Village South Specific Plan (Proposed) - Los Angeles-South Coast County, Annual

2.1 Overall Construction

Mitigated Construction

	ROG	NOx	CO	SO2	Fugitive PM10	Exhaust PM10	PM10 Total	Fugitive PM2.5	Exhaust PM2.5	PM2.5 Total	Bio- CO2	NBio- CO2	Total CO2	CH4	N2O	CO2e
Year	tons/yr										MT/yr					
2021	0.1713	1.8242	1.1662	2.4000e-003	0.4169	0.0817	0.4986	0.1795	0.0754	0.2549	0.0000	213.1967	213.1967	0.0601	0.0000	214.6991
2022	0.6904	4.1142	6.1625	0.0189	1.3058	0.1201	1.4259	0.3460	0.1128	0.4588	0.0000	1,721.6823	1,721.6823	0.1294	0.0000	1,724.9183
2023	0.6148	3.3648	5.6747	0.0178	1.1963	0.0996	1.2959	0.3203	0.0935	0.4138	0.0000	1,627.5291	1,627.5291	0.1185	0.0000	1,630.4921
2024	4.1619	0.1335	0.2810	5.9000e-004	0.0325	6.4700e-003	0.0390	8.6300e-003	6.0400e-003	0.0147	0.0000	52.9077	52.9077	8.0200e-003	0.0000	53.1082
Maximum	4.1619	4.1142	6.1625	0.0189	1.3058	0.1201	1.4259	0.3460	0.1128	0.4588	0.0000	1,721.6823	1,721.6823	0.1294	0.0000	1,724.9183

	ROG	NOx	CO	SO2	Fugitive PM10	Exhaust PM10	PM10 Total	Fugitive PM2.5	Exhaust PM2.5	PM2.5 Total	Bio- CO2	NBio-CO2	Total CO2	CH4	N2O	CO2e
Percent Reduction	0.00	0.00	0.00	0.00	0.00	0.00	0.00	0.00	0.00	0.00	0.00	0.00	0.00	0.00	0.00	0.00

Quarter	Start Date	End Date	Maximum Unmitigated ROG + NOX (tons/quarter)	Maximum Mitigated ROG + NOX (tons/quarter)
1	9-1-2021	11-30-2021	1.4103	1.4103
2	12-1-2021	2-28-2022	1.3613	1.3613
3	3-1-2022	5-31-2022	1.1985	1.1985
4	6-1-2022	8-31-2022	1.1921	1.1921
5	9-1-2022	11-30-2022	1.1918	1.1918
6	12-1-2022	2-28-2023	1.0774	1.0774
7	3-1-2023	5-31-2023	1.0320	1.0320
8	6-1-2023	8-31-2023	1.0260	1.0260

Village South Specific Plan (Proposed) - Los Angeles-South Coast County, Annual

9	9-1-2023	11-30-2023	1.0265	1.0265
10	12-1-2023	2-29-2024	2.8857	2.8857
11	3-1-2024	5-31-2024	1.6207	1.6207
		Highest	2.8857	2.8857

2.2 Overall Operational
Unmitigated Operational

	ROG	NOx	CO	SO2	Fugitive PM10	Exhaust PM10	PM10 Total	Fugitive PM2.5	Exhaust PM2.5	PM2.5 Total	Bio- CO2	NBio- CO2	Total CO2	CH4	N2O	CO2e
Category	tons/yr										MT/yr					
Area	5.1437	0.2950	10.3804	1.6700e-003		0.0714	0.0714		0.0714	0.0714	0.0000	220.9670	220.9670	0.0201	3.7400e-003	222.5835
Energy	0.1398	1.2312	0.7770	7.6200e-003		0.0966	0.0966		0.0966	0.0966	0.0000	3,896.0732	3,896.0732	0.1303	0.0468	3,913.2833
Mobile	1.5857	7.9962	19.1834	0.0821	7.7979	0.0580	7.8559	2.0895	0.0539	2.1434	0.0000	7,620.4986	7,620.4986	0.3407	0.0000	7,629.0162
Waste						0.0000	0.0000		0.0000	0.0000	207.8079	0.0000	207.8079	12.2811	0.0000	514.8354
Water						0.0000	0.0000		0.0000	0.0000	29.1632	556.6420	585.8052	3.0183	0.0755	683.7567
Total	6.8692	9.5223	30.3407	0.0914	7.7979	0.2260	8.0240	2.0895	0.2219	2.3114	236.9712	12,294.1807	12,531.1519	15.7904	0.1260	12,963.4751

Village South Specific Plan (Proposed) - Los Angeles-South Coast County, Annual

2.2 Overall Operational

Mitigated Operational

	ROG	NOx	CO	SO2	Fugitive PM10	Exhaust PM10	PM10 Total	Fugitive PM2.5	Exhaust PM2.5	PM2.5 Total	Bio- CO2	NBio- CO2	Total CO2	CH4	N2O	CO2e
Category	tons/yr										MT/yr					
Area	5.1437	0.2950	10.3804	1.6700e-003		0.0714	0.0714		0.0714	0.0714	0.0000	220.9670	220.9670	0.0201	3.7400e-003	222.5835
Energy	0.1398	1.2312	0.7770	7.6200e-003		0.0966	0.0966		0.0966	0.0966	0.0000	3,896.0732	3,896.0732	0.1303	0.0468	3,913.2833
Mobile	1.5857	7.9962	19.1834	0.0821	7.7979	0.0580	7.8559	2.0895	0.0539	2.1434	0.0000	7,620.4986	7,620.4986	0.3407	0.0000	7,629.0162
Waste						0.0000	0.0000		0.0000	0.0000	207.8079	0.0000	207.8079	12.2811	0.0000	514.8354
Water						0.0000	0.0000		0.0000	0.0000	29.1632	556.6420	585.8052	3.0183	0.0755	683.7567
Total	6.8692	9.5223	30.3407	0.0914	7.7979	0.2260	8.0240	2.0895	0.2219	2.3114	236.9712	12,294.1807	12,531.1519	15.7904	0.1260	12,963.4751

	ROG	NOx	CO	SO2	Fugitive PM10	Exhaust PM10	PM10 Total	Fugitive PM2.5	Exhaust PM2.5	PM2.5 Total	Bio- CO2	NBio- CO2	Total CO2	CH4	N2O	CO2e
Percent Reduction	0.00	0.00	0.00	0.00	0.00	0.00	0.00	0.00	0.00	0.00	0.00	0.00	0.00	0.00	0.00	0.00

3.0 Construction Detail

Construction Phase

Village South Specific Plan (Proposed) - Los Angeles-South Coast County, Annual

Phase Number	Phase Name	Phase Type	Start Date	End Date	Num Days Week	Num Days	Phase Description
1	Demolition	Demolition	9/1/2021	10/12/2021	5	30	
2	Site Preparation	Site Preparation	10/13/2021	11/9/2021	5	20	
3	Grading	Grading	11/10/2021	1/11/2022	5	45	
4	Building Construction	Building Construction	1/12/2022	12/12/2023	5	500	
5	Paving	Paving	12/13/2023	1/30/2024	5	35	
6	Architectural Coating	Architectural Coating	1/31/2024	3/19/2024	5	35	

Acres of Grading (Site Preparation Phase): 0

Acres of Grading (Grading Phase): 112.5

Acres of Paving: 0

Residential Indoor: 2,025,000; Residential Outdoor: 675,000; Non-Residential Indoor: 326,400; Non-Residential Outdoor: 108,800; Striped Parking Area: 0 (Architectural Coating – sqft)

OffRoad Equipment

Village South Specific Plan (Proposed) - Los Angeles-South Coast County, Annual

Phase Name	Offroad Equipment Type	Amount	Usage Hours	Horse Power	Load Factor
Demolition	Concrete/Industrial Saws	1	8.00	81	0.73
Demolition	Excavators	3	8.00	158	0.38
Demolition	Rubber Tired Dozers	2	8.00	247	0.40
Site Preparation	Rubber Tired Dozers	3	8.00	247	0.40
Site Preparation	Tractors/Loaders/Backhoes	4	8.00	97	0.37
Grading	Excavators	2	8.00	158	0.38
Grading	Graders	1	8.00	187	0.41
Grading	Rubber Tired Dozers	1	8.00	247	0.40
Grading	Scrapers	2	8.00	367	0.48
Grading	Tractors/Loaders/Backhoes	2	8.00	97	0.37
Building Construction	Cranes	1	7.00	231	0.29
Building Construction	Forklifts	3	8.00	89	0.20
Building Construction	Generator Sets	1	8.00	84	0.74
Building Construction	Tractors/Loaders/Backhoes	3	7.00	97	0.37
Building Construction	Welders	1	8.00	46	0.45
Paving	Pavers	2	8.00	130	0.42
Paving	Paving Equipment	2	8.00	132	0.36
Paving	Rollers	2	8.00	80	0.38
Architectural Coating	Air Compressors	1	6.00	78	0.48

Trips and VMT

Village South Specific Plan (Proposed) - Los Angeles-South Coast County, Annual

Phase Name	Offroad Equipment Count	Worker Trip Number	Vendor Trip Number	Hauling Trip Number	Worker Trip Length	Vendor Trip Length	Hauling Trip Length	Worker Vehicle Class	Vendor Vehicle Class	Hauling Vehicle Class
Demolition	6	15.00	0.00	458.00	14.70	6.90	20.00	LD_Mix	HDT_Mix	HHDT
Site Preparation	7	18.00	0.00	0.00	14.70	6.90	20.00	LD_Mix	HDT_Mix	HHDT
Grading	8	20.00	0.00	0.00	14.70	6.90	20.00	LD_Mix	HDT_Mix	HHDT
Building Construction	9	801.00	143.00	0.00	14.70	6.90	20.00	LD_Mix	HDT_Mix	HHDT
Paving	6	15.00	0.00	0.00	14.70	6.90	20.00	LD_Mix	HDT_Mix	HHDT
Architectural Coating	1	160.00	0.00	0.00	14.70	6.90	20.00	LD_Mix	HDT_Mix	HHDT

3.1 Mitigation Measures Construction

3.2 Demolition - 2021

Unmitigated Construction On-Site

	ROG	NOx	CO	SO2	Fugitive PM10	Exhaust PM10	PM10 Total	Fugitive PM2.5	Exhaust PM2.5	PM2.5 Total	Bio- CO2	NBio- CO2	Total CO2	CH4	N2O	CO2e
Category	tons/yr										MT/yr					
Fugitive Dust					0.0496	0.0000	0.0496	7.5100e-003	0.0000	7.5100e-003	0.0000	0.0000	0.0000	0.0000	0.0000	0.0000
Off-Road	0.0475	0.4716	0.3235	5.8000e-004		0.0233	0.0233		0.0216	0.0216	0.0000	51.0012	51.0012	0.0144	0.0000	51.3601
Total	0.0475	0.4716	0.3235	5.8000e-004	0.0496	0.0233	0.0729	7.5100e-003	0.0216	0.0291	0.0000	51.0012	51.0012	0.0144	0.0000	51.3601

Village South Specific Plan (Proposed) - Los Angeles-South Coast County, Annual

3.2 Demolition - 2021

Unmitigated Construction Off-Site

	ROG	NOx	CO	SO2	Fugitive PM10	Exhaust PM10	PM10 Total	Fugitive PM2.5	Exhaust PM2.5	PM2.5 Total	Bio- CO2	NBio- CO2	Total CO2	CH4	N2O	CO2e
Category	tons/yr										MT/yr					
Hauling	1.9300e-003	0.0634	0.0148	1.8000e-004	3.9400e-003	1.9000e-004	4.1300e-003	1.0800e-003	1.8000e-004	1.2600e-003	0.0000	17.4566	17.4566	1.2100e-003	0.0000	17.4869
Vendor	0.0000	0.0000	0.0000	0.0000	0.0000	0.0000	0.0000	0.0000	0.0000	0.0000	0.0000	0.0000	0.0000	0.0000	0.0000	0.0000
Worker	9.7000e-004	7.5000e-004	8.5100e-003	2.0000e-005	2.4700e-003	2.0000e-005	2.4900e-003	6.5000e-004	2.0000e-005	6.7000e-004	0.0000	2.2251	2.2251	7.0000e-005	0.0000	2.2267
Total	2.9000e-003	0.0641	0.0233	2.0000e-004	6.4100e-003	2.1000e-004	6.6200e-003	1.7300e-003	2.0000e-004	1.9300e-003	0.0000	19.6816	19.6816	1.2800e-003	0.0000	19.7136

Mitigated Construction On-Site

	ROG	NOx	CO	SO2	Fugitive PM10	Exhaust PM10	PM10 Total	Fugitive PM2.5	Exhaust PM2.5	PM2.5 Total	Bio- CO2	NBio- CO2	Total CO2	CH4	N2O	CO2e
Category	tons/yr										MT/yr					
Fugitive Dust					0.0496	0.0000	0.0496	7.5100e-003	0.0000	7.5100e-003	0.0000	0.0000	0.0000	0.0000	0.0000	0.0000
Off-Road	0.0475	0.4716	0.3235	5.8000e-004		0.0233	0.0233		0.0216	0.0216	0.0000	51.0011	51.0011	0.0144	0.0000	51.3600
Total	0.0475	0.4716	0.3235	5.8000e-004	0.0496	0.0233	0.0729	7.5100e-003	0.0216	0.0291	0.0000	51.0011	51.0011	0.0144	0.0000	51.3600

Village South Specific Plan (Proposed) - Los Angeles-South Coast County, Annual

3.2 Demolition - 2021

Mitigated Construction Off-Site

	ROG	NOx	CO	SO2	Fugitive PM10	Exhaust PM10	PM10 Total	Fugitive PM2.5	Exhaust PM2.5	PM2.5 Total	Bio- CO2	NBio- CO2	Total CO2	CH4	N2O	CO2e
Category	tons/yr										MT/yr					
Hauling	1.9300e-003	0.0634	0.0148	1.8000e-004	3.9400e-003	1.9000e-004	4.1300e-003	1.0800e-003	1.8000e-004	1.2600e-003	0.0000	17.4566	17.4566	1.2100e-003	0.0000	17.4869
Vendor	0.0000	0.0000	0.0000	0.0000	0.0000	0.0000	0.0000	0.0000	0.0000	0.0000	0.0000	0.0000	0.0000	0.0000	0.0000	0.0000
Worker	9.7000e-004	7.5000e-004	8.5100e-003	2.0000e-005	2.4700e-003	2.0000e-005	2.4900e-003	6.5000e-004	2.0000e-005	6.7000e-004	0.0000	2.2251	2.2251	7.0000e-005	0.0000	2.2267
Total	2.9000e-003	0.0641	0.0233	2.0000e-004	6.4100e-003	2.1000e-004	6.6200e-003	1.7300e-003	2.0000e-004	1.9300e-003	0.0000	19.6816	19.6816	1.2800e-003	0.0000	19.7136

3.3 Site Preparation - 2021

Unmitigated Construction On-Site

	ROG	NOx	CO	SO2	Fugitive PM10	Exhaust PM10	PM10 Total	Fugitive PM2.5	Exhaust PM2.5	PM2.5 Total	Bio- CO2	NBio- CO2	Total CO2	CH4	N2O	CO2e
Category	tons/yr										MT/yr					
Fugitive Dust					0.1807	0.0000	0.1807	0.0993	0.0000	0.0993	0.0000	0.0000	0.0000	0.0000	0.0000	0.0000
Off-Road	0.0389	0.4050	0.2115	3.8000e-004		0.0204	0.0204		0.0188	0.0188	0.0000	33.4357	33.4357	0.0108	0.0000	33.7061
Total	0.0389	0.4050	0.2115	3.8000e-004	0.1807	0.0204	0.2011	0.0993	0.0188	0.1181	0.0000	33.4357	33.4357	0.0108	0.0000	33.7061

Village South Specific Plan (Proposed) - Los Angeles-South Coast County, Annual

3.3 Site Preparation - 2021

Unmitigated Construction Off-Site

	ROG	NOx	CO	SO2	Fugitive PM10	Exhaust PM10	PM10 Total	Fugitive PM2.5	Exhaust PM2.5	PM2.5 Total	Bio- CO2	NBio- CO2	Total CO2	CH4	N2O	CO2e
Category	tons/yr										MT/yr					
Hauling	0.0000	0.0000	0.0000	0.0000	0.0000	0.0000	0.0000	0.0000	0.0000	0.0000	0.0000	0.0000	0.0000	0.0000	0.0000	0.0000
Vendor	0.0000	0.0000	0.0000	0.0000	0.0000	0.0000	0.0000	0.0000	0.0000	0.0000	0.0000	0.0000	0.0000	0.0000	0.0000	0.0000
Worker	7.7000e-004	6.0000e-004	6.8100e-003	2.0000e-005	1.9700e-003	2.0000e-005	1.9900e-003	5.2000e-004	1.0000e-005	5.4000e-004	0.0000	1.7801	1.7801	5.0000e-005	0.0000	1.7814
Total	7.7000e-004	6.0000e-004	6.8100e-003	2.0000e-005	1.9700e-003	2.0000e-005	1.9900e-003	5.2000e-004	1.0000e-005	5.4000e-004	0.0000	1.7801	1.7801	5.0000e-005	0.0000	1.7814

Mitigated Construction On-Site

	ROG	NOx	CO	SO2	Fugitive PM10	Exhaust PM10	PM10 Total	Fugitive PM2.5	Exhaust PM2.5	PM2.5 Total	Bio- CO2	NBio- CO2	Total CO2	CH4	N2O	CO2e
Category	tons/yr										MT/yr					
Fugitive Dust					0.1807	0.0000	0.1807	0.0993	0.0000	0.0993	0.0000	0.0000	0.0000	0.0000	0.0000	0.0000
Off-Road	0.0389	0.4050	0.2115	3.8000e-004		0.0204	0.0204		0.0188	0.0188	0.0000	33.4357	33.4357	0.0108	0.0000	33.7060
Total	0.0389	0.4050	0.2115	3.8000e-004	0.1807	0.0204	0.2011	0.0993	0.0188	0.1181	0.0000	33.4357	33.4357	0.0108	0.0000	33.7060

Village South Specific Plan (Proposed) - Los Angeles-South Coast County, Annual

3.3 Site Preparation - 2021

Mitigated Construction Off-Site

	ROG	NOx	CO	SO2	Fugitive PM10	Exhaust PM10	PM10 Total	Fugitive PM2.5	Exhaust PM2.5	PM2.5 Total	Bio- CO2	NBio- CO2	Total CO2	CH4	N2O	CO2e
Category	tons/yr										MT/yr					
Hauling	0.0000	0.0000	0.0000	0.0000	0.0000	0.0000	0.0000	0.0000	0.0000	0.0000	0.0000	0.0000	0.0000	0.0000	0.0000	0.0000
Vendor	0.0000	0.0000	0.0000	0.0000	0.0000	0.0000	0.0000	0.0000	0.0000	0.0000	0.0000	0.0000	0.0000	0.0000	0.0000	0.0000
Worker	7.7000e-004	6.0000e-004	6.8100e-003	2.0000e-005	1.9700e-003	2.0000e-005	1.9900e-003	5.2000e-004	1.0000e-005	5.4000e-004	0.0000	1.7801	1.7801	5.0000e-005	0.0000	1.7814
Total	7.7000e-004	6.0000e-004	6.8100e-003	2.0000e-005	1.9700e-003	2.0000e-005	1.9900e-003	5.2000e-004	1.0000e-005	5.4000e-004	0.0000	1.7801	1.7801	5.0000e-005	0.0000	1.7814

3.4 Grading - 2021

Unmitigated Construction On-Site

	ROG	NOx	CO	SO2	Fugitive PM10	Exhaust PM10	PM10 Total	Fugitive PM2.5	Exhaust PM2.5	PM2.5 Total	Bio- CO2	NBio- CO2	Total CO2	CH4	N2O	CO2e
Category	tons/yr										MT/yr					
Fugitive Dust					0.1741	0.0000	0.1741	0.0693	0.0000	0.0693	0.0000	0.0000	0.0000	0.0000	0.0000	0.0000
Off-Road	0.0796	0.8816	0.5867	1.1800e-003		0.0377	0.0377		0.0347	0.0347	0.0000	103.5405	103.5405	0.0335	0.0000	104.3776
Total	0.0796	0.8816	0.5867	1.1800e-003	0.1741	0.0377	0.2118	0.0693	0.0347	0.1040	0.0000	103.5405	103.5405	0.0335	0.0000	104.3776

Village South Specific Plan (Proposed) - Los Angeles-South Coast County, Annual

3.4 Grading - 2021

Unmitigated Construction Off-Site

	ROG	NOx	CO	SO2	Fugitive PM10	Exhaust PM10	PM10 Total	Fugitive PM2.5	Exhaust PM2.5	PM2.5 Total	Bio- CO2	NBio- CO2	Total CO2	CH4	N2O	CO2e
Category	tons/yr										MT/yr					
Hauling	0.0000	0.0000	0.0000	0.0000	0.0000	0.0000	0.0000	0.0000	0.0000	0.0000	0.0000	0.0000	0.0000	0.0000	0.0000	0.0000
Vendor	0.0000	0.0000	0.0000	0.0000	0.0000	0.0000	0.0000	0.0000	0.0000	0.0000	0.0000	0.0000	0.0000	0.0000	0.0000	0.0000
Worker	1.6400e-003	1.2700e-003	0.0144	4.0000e-005	4.1600e-003	3.0000e-005	4.2000e-003	1.1100e-003	3.0000e-005	1.1400e-003	0.0000	3.7579	3.7579	1.1000e-004	0.0000	3.7607
Total	1.6400e-003	1.2700e-003	0.0144	4.0000e-005	4.1600e-003	3.0000e-005	4.2000e-003	1.1100e-003	3.0000e-005	1.1400e-003	0.0000	3.7579	3.7579	1.1000e-004	0.0000	3.7607

Mitigated Construction On-Site

	ROG	NOx	CO	SO2	Fugitive PM10	Exhaust PM10	PM10 Total	Fugitive PM2.5	Exhaust PM2.5	PM2.5 Total	Bio- CO2	NBio- CO2	Total CO2	CH4	N2O	CO2e
Category	tons/yr										MT/yr					
Fugitive Dust					0.1741	0.0000	0.1741	0.0693	0.0000	0.0693	0.0000	0.0000	0.0000	0.0000	0.0000	0.0000
Off-Road	0.0796	0.8816	0.5867	1.1800e-003		0.0377	0.0377		0.0347	0.0347	0.0000	103.5403	103.5403	0.0335	0.0000	104.3775
Total	0.0796	0.8816	0.5867	1.1800e-003	0.1741	0.0377	0.2118	0.0693	0.0347	0.1040	0.0000	103.5403	103.5403	0.0335	0.0000	104.3775

Village South Specific Plan (Proposed) - Los Angeles-South Coast County, Annual

3.4 Grading - 2021

Mitigated Construction Off-Site

	ROG	NOx	CO	SO2	Fugitive PM10	Exhaust PM10	PM10 Total	Fugitive PM2.5	Exhaust PM2.5	PM2.5 Total	Bio- CO2	NBio- CO2	Total CO2	CH4	N2O	CO2e
Category	tons/yr										MT/yr					
Hauling	0.0000	0.0000	0.0000	0.0000	0.0000	0.0000	0.0000	0.0000	0.0000	0.0000	0.0000	0.0000	0.0000	0.0000	0.0000	0.0000
Vendor	0.0000	0.0000	0.0000	0.0000	0.0000	0.0000	0.0000	0.0000	0.0000	0.0000	0.0000	0.0000	0.0000	0.0000	0.0000	0.0000
Worker	1.6400e-003	1.2700e-003	0.0144	4.0000e-005	4.1600e-003	3.0000e-005	4.2000e-003	1.1100e-003	3.0000e-005	1.1400e-003	0.0000	3.7579	3.7579	1.1000e-004	0.0000	3.7607
Total	1.6400e-003	1.2700e-003	0.0144	4.0000e-005	4.1600e-003	3.0000e-005	4.2000e-003	1.1100e-003	3.0000e-005	1.1400e-003	0.0000	3.7579	3.7579	1.1000e-004	0.0000	3.7607

3.4 Grading - 2022

Unmitigated Construction On-Site

	ROG	NOx	CO	SO2	Fugitive PM10	Exhaust PM10	PM10 Total	Fugitive PM2.5	Exhaust PM2.5	PM2.5 Total	Bio- CO2	NBio- CO2	Total CO2	CH4	N2O	CO2e
Category	tons/yr										MT/yr					
Fugitive Dust					0.0807	0.0000	0.0807	0.0180	0.0000	0.0180	0.0000	0.0000	0.0000	0.0000	0.0000	0.0000
Off-Road	0.0127	0.1360	0.1017	2.2000e-004		5.7200e-003	5.7200e-003		5.2600e-003	5.2600e-003	0.0000	19.0871	19.0871	6.1700e-003	0.0000	19.2414
Total	0.0127	0.1360	0.1017	2.2000e-004	0.0807	5.7200e-003	0.0865	0.0180	5.2600e-003	0.0233	0.0000	19.0871	19.0871	6.1700e-003	0.0000	19.2414

Village South Specific Plan (Proposed) - Los Angeles-South Coast County, Annual

3.4 Grading - 2022

Unmitigated Construction Off-Site

	ROG	NOx	CO	SO2	Fugitive PM10	Exhaust PM10	PM10 Total	Fugitive PM2.5	Exhaust PM2.5	PM2.5 Total	Bio- CO2	NBio- CO2	Total CO2	CH4	N2O	CO2e
Category	tons/yr										MT/yr					
Hauling	0.0000	0.0000	0.0000	0.0000	0.0000	0.0000	0.0000	0.0000	0.0000	0.0000	0.0000	0.0000	0.0000	0.0000	0.0000	0.0000
Vendor	0.0000	0.0000	0.0000	0.0000	0.0000	0.0000	0.0000	0.0000	0.0000	0.0000	0.0000	0.0000	0.0000	0.0000	0.0000	0.0000
Worker	2.8000e-004	2.1000e-004	2.4400e-003	1.0000e-005	7.7000e-004	1.0000e-005	7.7000e-004	2.0000e-004	1.0000e-005	2.1000e-004	0.0000	0.6679	0.6679	2.0000e-005	0.0000	0.6684
Total	2.8000e-004	2.1000e-004	2.4400e-003	1.0000e-005	7.7000e-004	1.0000e-005	7.7000e-004	2.0000e-004	1.0000e-005	2.1000e-004	0.0000	0.6679	0.6679	2.0000e-005	0.0000	0.6684

Mitigated Construction On-Site

	ROG	NOx	CO	SO2	Fugitive PM10	Exhaust PM10	PM10 Total	Fugitive PM2.5	Exhaust PM2.5	PM2.5 Total	Bio- CO2	NBio- CO2	Total CO2	CH4	N2O	CO2e
Category	tons/yr										MT/yr					
Fugitive Dust					0.0807	0.0000	0.0807	0.0180	0.0000	0.0180	0.0000	0.0000	0.0000	0.0000	0.0000	0.0000
Off-Road	0.0127	0.1360	0.1017	2.2000e-004		5.7200e-003	5.7200e-003		5.2600e-003	5.2600e-003	0.0000	19.0871	19.0871	6.1700e-003	0.0000	19.2414
Total	0.0127	0.1360	0.1017	2.2000e-004	0.0807	5.7200e-003	0.0865	0.0180	5.2600e-003	0.0233	0.0000	19.0871	19.0871	6.1700e-003	0.0000	19.2414

Village South Specific Plan (Proposed) - Los Angeles-South Coast County, Annual

3.4 Grading - 2022

Mitigated Construction Off-Site

	ROG	NOx	CO	SO2	Fugitive PM10	Exhaust PM10	PM10 Total	Fugitive PM2.5	Exhaust PM2.5	PM2.5 Total	Bio- CO2	NBio- CO2	Total CO2	CH4	N2O	CO2e
Category	tons/yr										MT/yr					
Hauling	0.0000	0.0000	0.0000	0.0000	0.0000	0.0000	0.0000	0.0000	0.0000	0.0000	0.0000	0.0000	0.0000	0.0000	0.0000	0.0000
Vendor	0.0000	0.0000	0.0000	0.0000	0.0000	0.0000	0.0000	0.0000	0.0000	0.0000	0.0000	0.0000	0.0000	0.0000	0.0000	0.0000
Worker	2.8000e-004	2.1000e-004	2.4400e-003	1.0000e-005	7.7000e-004	1.0000e-005	7.7000e-004	2.0000e-004	1.0000e-005	2.1000e-004	0.0000	0.6679	0.6679	2.0000e-005	0.0000	0.6684
Total	2.8000e-004	2.1000e-004	2.4400e-003	1.0000e-005	7.7000e-004	1.0000e-005	7.7000e-004	2.0000e-004	1.0000e-005	2.1000e-004	0.0000	0.6679	0.6679	2.0000e-005	0.0000	0.6684

3.5 Building Construction - 2022

Unmitigated Construction On-Site

	ROG	NOx	CO	SO2	Fugitive PM10	Exhaust PM10	PM10 Total	Fugitive PM2.5	Exhaust PM2.5	PM2.5 Total	Bio- CO2	NBio- CO2	Total CO2	CH4	N2O	CO2e
Category	tons/yr										MT/yr					
Off-Road	0.2158	1.9754	2.0700	3.4100e-003		0.1023	0.1023		0.0963	0.0963	0.0000	293.1324	293.1324	0.0702	0.0000	294.8881
Total	0.2158	1.9754	2.0700	3.4100e-003		0.1023	0.1023		0.0963	0.0963	0.0000	293.1324	293.1324	0.0702	0.0000	294.8881

Village South Specific Plan (Proposed) - Los Angeles-South Coast County, Annual

3.5 Building Construction - 2022

Unmitigated Construction Off-Site

	ROG	NOx	CO	SO2	Fugitive PM10	Exhaust PM10	PM10 Total	Fugitive PM2.5	Exhaust PM2.5	PM2.5 Total	Bio- CO2	NBio- CO2	Total CO2	CH4	N2O	CO2e
Category	tons/yr										MT/yr					
Hauling	0.0000	0.0000	0.0000	0.0000	0.0000	0.0000	0.0000	0.0000	0.0000	0.0000	0.0000	0.0000	0.0000	0.0000	0.0000	0.0000
Vendor	0.0527	1.6961	0.4580	4.5500e-003	0.1140	3.1800e-003	0.1171	0.0329	3.0400e-003	0.0359	0.0000	441.9835	441.9835	0.0264	0.0000	442.6435
Worker	0.4088	0.3066	3.5305	0.0107	1.1103	8.8700e-003	1.1192	0.2949	8.1700e-003	0.3031	0.0000	966.8117	966.8117	0.0266	0.0000	967.4773
Total	0.4616	2.0027	3.9885	0.0152	1.2243	0.0121	1.2363	0.3278	0.0112	0.3390	0.0000	1,408.7952	1,408.7952	0.0530	0.0000	1,410.1208

Mitigated Construction On-Site

	ROG	NOx	CO	SO2	Fugitive PM10	Exhaust PM10	PM10 Total	Fugitive PM2.5	Exhaust PM2.5	PM2.5 Total	Bio- CO2	NBio- CO2	Total CO2	CH4	N2O	CO2e
Category	tons/yr										MT/yr					
Off-Road	0.2158	1.9754	2.0700	3.4100e-003		0.1023	0.1023		0.0963	0.0963	0.0000	293.1321	293.1321	0.0702	0.0000	294.8877
Total	0.2158	1.9754	2.0700	3.4100e-003		0.1023	0.1023		0.0963	0.0963	0.0000	293.1321	293.1321	0.0702	0.0000	294.8877

Village South Specific Plan (Proposed) - Los Angeles-South Coast County, Annual

3.5 Building Construction - 2022

Mitigated Construction Off-Site

	ROG	NOx	CO	SO2	Fugitive PM10	Exhaust PM10	PM10 Total	Fugitive PM2.5	Exhaust PM2.5	PM2.5 Total	Bio- CO2	NBio- CO2	Total CO2	CH4	N2O	CO2e
Category	tons/yr										MT/yr					
Hauling	0.0000	0.0000	0.0000	0.0000	0.0000	0.0000	0.0000	0.0000	0.0000	0.0000	0.0000	0.0000	0.0000	0.0000	0.0000	0.0000
Vendor	0.0527	1.6961	0.4580	4.5500e-003	0.1140	3.1800e-003	0.1171	0.0329	3.0400e-003	0.0359	0.0000	441.9835	441.9835	0.0264	0.0000	442.6435
Worker	0.4088	0.3066	3.5305	0.0107	1.1103	8.8700e-003	1.1192	0.2949	8.1700e-003	0.3031	0.0000	966.8117	966.8117	0.0266	0.0000	967.4773
Total	0.4616	2.0027	3.9885	0.0152	1.2243	0.0121	1.2363	0.3278	0.0112	0.3390	0.0000	1,408.7952	1,408.7952	0.0530	0.0000	1,410.1208

3.5 Building Construction - 2023

Unmitigated Construction On-Site

	ROG	NOx	CO	SO2	Fugitive PM10	Exhaust PM10	PM10 Total	Fugitive PM2.5	Exhaust PM2.5	PM2.5 Total	Bio- CO2	NBio- CO2	Total CO2	CH4	N2O	CO2e
Category	tons/yr										MT/yr					
Off-Road	0.1942	1.7765	2.0061	3.3300e-003		0.0864	0.0864		0.0813	0.0813	0.0000	286.2789	286.2789	0.0681	0.0000	287.9814
Total	0.1942	1.7765	2.0061	3.3300e-003		0.0864	0.0864		0.0813	0.0813	0.0000	286.2789	286.2789	0.0681	0.0000	287.9814

Village South Specific Plan (Proposed) - Los Angeles-South Coast County, Annual

3.5 Building Construction - 2023

Unmitigated Construction Off-Site

	ROG	NOx	CO	SO2	Fugitive PM10	Exhaust PM10	PM10 Total	Fugitive PM2.5	Exhaust PM2.5	PM2.5 Total	Bio- CO2	NBio- CO2	Total CO2	CH4	N2O	CO2e
Category	tons/yr										MT/yr					
Hauling	0.0000	0.0000	0.0000	0.0000	0.0000	0.0000	0.0000	0.0000	0.0000	0.0000	0.0000	0.0000	0.0000	0.0000	0.0000	0.0000
Vendor	0.0382	1.2511	0.4011	4.3000e-003	0.1113	1.4600e-003	0.1127	0.0321	1.4000e-003	0.0335	0.0000	417.9930	417.9930	0.0228	0.0000	418.5624
Worker	0.3753	0.2708	3.1696	0.0101	1.0840	8.4100e-003	1.0924	0.2879	7.7400e-003	0.2957	0.0000	909.3439	909.3439	0.0234	0.0000	909.9291
Total	0.4135	1.5218	3.5707	0.0144	1.1953	9.8700e-003	1.2051	0.3200	9.1400e-003	0.3292	0.0000	1,327.3369	1,327.3369	0.0462	0.0000	1,328.4916

Mitigated Construction On-Site

	ROG	NOx	CO	SO2	Fugitive PM10	Exhaust PM10	PM10 Total	Fugitive PM2.5	Exhaust PM2.5	PM2.5 Total	Bio- CO2	NBio- CO2	Total CO2	CH4	N2O	CO2e
Category	tons/yr										MT/yr					
Off-Road	0.1942	1.7765	2.0061	3.3300e-003		0.0864	0.0864		0.0813	0.0813	0.0000	286.2785	286.2785	0.0681	0.0000	287.9811
Total	0.1942	1.7765	2.0061	3.3300e-003		0.0864	0.0864		0.0813	0.0813	0.0000	286.2785	286.2785	0.0681	0.0000	287.9811

Village South Specific Plan (Proposed) - Los Angeles-South Coast County, Annual

3.5 Building Construction - 2023

Mitigated Construction Off-Site

	ROG	NOx	CO	SO2	Fugitive PM10	Exhaust PM10	PM10 Total	Fugitive PM2.5	Exhaust PM2.5	PM2.5 Total	Bio- CO2	NBio- CO2	Total CO2	CH4	N2O	CO2e
Category	tons/yr										MT/yr					
Hauling	0.0000	0.0000	0.0000	0.0000	0.0000	0.0000	0.0000	0.0000	0.0000	0.0000	0.0000	0.0000	0.0000	0.0000	0.0000	0.0000
Vendor	0.0382	1.2511	0.4011	4.3000e-003	0.1113	1.4600e-003	0.1127	0.0321	1.4000e-003	0.0335	0.0000	417.9930	417.9930	0.0228	0.0000	418.5624
Worker	0.3753	0.2708	3.1696	0.0101	1.0840	8.4100e-003	1.0924	0.2879	7.7400e-003	0.2957	0.0000	909.3439	909.3439	0.0234	0.0000	909.9291
Total	0.4135	1.5218	3.5707	0.0144	1.1953	9.8700e-003	1.2051	0.3200	9.1400e-003	0.3292	0.0000	1,327.3369	1,327.3369	0.0462	0.0000	1,328.4916

3.6 Paving - 2023

Unmitigated Construction On-Site

	ROG	NOx	CO	SO2	Fugitive PM10	Exhaust PM10	PM10 Total	Fugitive PM2.5	Exhaust PM2.5	PM2.5 Total	Bio- CO2	NBio- CO2	Total CO2	CH4	N2O	CO2e
Category	tons/yr										MT/yr					
Off-Road	6.7100e-003	0.0663	0.0948	1.5000e-004		3.3200e-003	3.3200e-003		3.0500e-003	3.0500e-003	0.0000	13.0175	13.0175	4.2100e-003	0.0000	13.1227
Paving	0.0000					0.0000	0.0000		0.0000	0.0000	0.0000	0.0000	0.0000	0.0000	0.0000	0.0000
Total	6.7100e-003	0.0663	0.0948	1.5000e-004		3.3200e-003	3.3200e-003		3.0500e-003	3.0500e-003	0.0000	13.0175	13.0175	4.2100e-003	0.0000	13.1227

Village South Specific Plan (Proposed) - Los Angeles-South Coast County, Annual

3.6 Paving - 2023

Unmitigated Construction Off-Site

	ROG	NOx	CO	SO2	Fugitive PM10	Exhaust PM10	PM10 Total	Fugitive PM2.5	Exhaust PM2.5	PM2.5 Total	Bio- CO2	NBio- CO2	Total CO2	CH4	N2O	CO2e
Category	tons/yr										MT/yr					
Hauling	0.0000	0.0000	0.0000	0.0000	0.0000	0.0000	0.0000	0.0000	0.0000	0.0000	0.0000	0.0000	0.0000	0.0000	0.0000	0.0000
Vendor	0.0000	0.0000	0.0000	0.0000	0.0000	0.0000	0.0000	0.0000	0.0000	0.0000	0.0000	0.0000	0.0000	0.0000	0.0000	0.0000
Worker	3.7000e-004	2.7000e-004	3.1200e-003	1.0000e-005	1.0700e-003	1.0000e-005	1.0800e-003	2.8000e-004	1.0000e-005	2.9000e-004	0.0000	0.8963	0.8963	2.0000e-005	0.0000	0.8968
Total	3.7000e-004	2.7000e-004	3.1200e-003	1.0000e-005	1.0700e-003	1.0000e-005	1.0800e-003	2.8000e-004	1.0000e-005	2.9000e-004	0.0000	0.8963	0.8963	2.0000e-005	0.0000	0.8968

Mitigated Construction On-Site

	ROG	NOx	CO	SO2	Fugitive PM10	Exhaust PM10	PM10 Total	Fugitive PM2.5	Exhaust PM2.5	PM2.5 Total	Bio- CO2	NBio- CO2	Total CO2	CH4	N2O	CO2e
Category	tons/yr										MT/yr					
Off-Road	6.7100e-003	0.0663	0.0948	1.5000e-004		3.3200e-003	3.3200e-003		3.0500e-003	3.0500e-003	0.0000	13.0175	13.0175	4.2100e-003	0.0000	13.1227
Paving	0.0000					0.0000	0.0000		0.0000	0.0000	0.0000	0.0000	0.0000	0.0000	0.0000	0.0000
Total	6.7100e-003	0.0663	0.0948	1.5000e-004		3.3200e-003	3.3200e-003		3.0500e-003	3.0500e-003	0.0000	13.0175	13.0175	4.2100e-003	0.0000	13.1227

Village South Specific Plan (Proposed) - Los Angeles-South Coast County, Annual

3.6 Paving - 2023

Mitigated Construction Off-Site

	ROG	NOx	CO	SO2	Fugitive PM10	Exhaust PM10	PM10 Total	Fugitive PM2.5	Exhaust PM2.5	PM2.5 Total	Bio- CO2	NBio- CO2	Total CO2	CH4	N2O	CO2e
Category	tons/yr										MT/yr					
Hauling	0.0000	0.0000	0.0000	0.0000	0.0000	0.0000	0.0000	0.0000	0.0000	0.0000	0.0000	0.0000	0.0000	0.0000	0.0000	0.0000
Vendor	0.0000	0.0000	0.0000	0.0000	0.0000	0.0000	0.0000	0.0000	0.0000	0.0000	0.0000	0.0000	0.0000	0.0000	0.0000	0.0000
Worker	3.7000e-004	2.7000e-004	3.1200e-003	1.0000e-005	1.0700e-003	1.0000e-005	1.0800e-003	2.8000e-004	1.0000e-005	2.9000e-004	0.0000	0.8963	0.8963	2.0000e-005	0.0000	0.8968
Total	3.7000e-004	2.7000e-004	3.1200e-003	1.0000e-005	1.0700e-003	1.0000e-005	1.0800e-003	2.8000e-004	1.0000e-005	2.9000e-004	0.0000	0.8963	0.8963	2.0000e-005	0.0000	0.8968

3.6 Paving - 2024

Unmitigated Construction On-Site

	ROG	NOx	CO	SO2	Fugitive PM10	Exhaust PM10	PM10 Total	Fugitive PM2.5	Exhaust PM2.5	PM2.5 Total	Bio- CO2	NBio- CO2	Total CO2	CH4	N2O	CO2e
Category	tons/yr										MT/yr					
Off-Road	0.0109	0.1048	0.1609	2.5000e-004		5.1500e-003	5.1500e-003		4.7400e-003	4.7400e-003	0.0000	22.0292	22.0292	7.1200e-003	0.0000	22.2073
Paving	0.0000					0.0000	0.0000		0.0000	0.0000	0.0000	0.0000	0.0000	0.0000	0.0000	0.0000
Total	0.0109	0.1048	0.1609	2.5000e-004		5.1500e-003	5.1500e-003		4.7400e-003	4.7400e-003	0.0000	22.0292	22.0292	7.1200e-003	0.0000	22.2073

Village South Specific Plan (Proposed) - Los Angeles-South Coast County, Annual

3.6 Paving - 2024

Unmitigated Construction Off-Site

	ROG	NOx	CO	SO2	Fugitive PM10	Exhaust PM10	PM10 Total	Fugitive PM2.5	Exhaust PM2.5	PM2.5 Total	Bio- CO2	NBio- CO2	Total CO2	CH4	N2O	CO2e
Category	tons/yr										MT/yr					
Hauling	0.0000	0.0000	0.0000	0.0000	0.0000	0.0000	0.0000	0.0000	0.0000	0.0000	0.0000	0.0000	0.0000	0.0000	0.0000	0.0000
Vendor	0.0000	0.0000	0.0000	0.0000	0.0000	0.0000	0.0000	0.0000	0.0000	0.0000	0.0000	0.0000	0.0000	0.0000	0.0000	0.0000
Worker	5.9000e-004	4.1000e-004	4.9200e-003	2.0000e-005	1.8100e-003	1.0000e-005	1.8200e-003	4.8000e-004	1.0000e-005	4.9000e-004	0.0000	1.4697	1.4697	4.0000e-005	0.0000	1.4706
Total	5.9000e-004	4.1000e-004	4.9200e-003	2.0000e-005	1.8100e-003	1.0000e-005	1.8200e-003	4.8000e-004	1.0000e-005	4.9000e-004	0.0000	1.4697	1.4697	4.0000e-005	0.0000	1.4706

Mitigated Construction On-Site

	ROG	NOx	CO	SO2	Fugitive PM10	Exhaust PM10	PM10 Total	Fugitive PM2.5	Exhaust PM2.5	PM2.5 Total	Bio- CO2	NBio- CO2	Total CO2	CH4	N2O	CO2e
Category	tons/yr										MT/yr					
Off-Road	0.0109	0.1048	0.1609	2.5000e-004		5.1500e-003	5.1500e-003		4.7400e-003	4.7400e-003	0.0000	22.0292	22.0292	7.1200e-003	0.0000	22.2073
Paving	0.0000					0.0000	0.0000		0.0000	0.0000	0.0000	0.0000	0.0000	0.0000	0.0000	0.0000
Total	0.0109	0.1048	0.1609	2.5000e-004		5.1500e-003	5.1500e-003		4.7400e-003	4.7400e-003	0.0000	22.0292	22.0292	7.1200e-003	0.0000	22.2073

Village South Specific Plan (Proposed) - Los Angeles-South Coast County, Annual

3.6 Paving - 2024

Mitigated Construction Off-Site

	ROG	NOx	CO	SO2	Fugitive PM10	Exhaust PM10	PM10 Total	Fugitive PM2.5	Exhaust PM2.5	PM2.5 Total	Bio- CO2	NBio- CO2	Total CO2	CH4	N2O	CO2e
Category	tons/yr										MT/yr					
Hauling	0.0000	0.0000	0.0000	0.0000	0.0000	0.0000	0.0000	0.0000	0.0000	0.0000	0.0000	0.0000	0.0000	0.0000	0.0000	0.0000
Vendor	0.0000	0.0000	0.0000	0.0000	0.0000	0.0000	0.0000	0.0000	0.0000	0.0000	0.0000	0.0000	0.0000	0.0000	0.0000	0.0000
Worker	5.9000e-004	4.1000e-004	4.9200e-003	2.0000e-005	1.8100e-003	1.0000e-005	1.8200e-003	4.8000e-004	1.0000e-005	4.9000e-004	0.0000	1.4697	1.4697	4.0000e-005	0.0000	1.4706
Total	5.9000e-004	4.1000e-004	4.9200e-003	2.0000e-005	1.8100e-003	1.0000e-005	1.8200e-003	4.8000e-004	1.0000e-005	4.9000e-004	0.0000	1.4697	1.4697	4.0000e-005	0.0000	1.4706

3.7 Architectural Coating - 2024

Unmitigated Construction On-Site

	ROG	NOx	CO	SO2	Fugitive PM10	Exhaust PM10	PM10 Total	Fugitive PM2.5	Exhaust PM2.5	PM2.5 Total	Bio- CO2	NBio- CO2	Total CO2	CH4	N2O	CO2e
Category	tons/yr										MT/yr					
Archit. Coating	4.1372					0.0000	0.0000		0.0000	0.0000	0.0000	0.0000	0.0000	0.0000	0.0000	0.0000
Off-Road	3.1600e-003	0.0213	0.0317	5.0000e-005		1.0700e-003	1.0700e-003		1.0700e-003	1.0700e-003	0.0000	4.4682	4.4682	2.5000e-004	0.0000	4.4745
Total	4.1404	0.0213	0.0317	5.0000e-005		1.0700e-003	1.0700e-003		1.0700e-003	1.0700e-003	0.0000	4.4682	4.4682	2.5000e-004	0.0000	4.4745

Village South Specific Plan (Proposed) - Los Angeles-South Coast County, Annual

3.7 Architectural Coating - 2024

Unmitigated Construction Off-Site

	ROG	NOx	CO	SO2	Fugitive PM10	Exhaust PM10	PM10 Total	Fugitive PM2.5	Exhaust PM2.5	PM2.5 Total	Bio- CO2	NBio- CO2	Total CO2	CH4	N2O	CO2e
Category	tons/yr										MT/yr					
Hauling	0.0000	0.0000	0.0000	0.0000	0.0000	0.0000	0.0000	0.0000	0.0000	0.0000	0.0000	0.0000	0.0000	0.0000	0.0000	0.0000
Vendor	0.0000	0.0000	0.0000	0.0000	0.0000	0.0000	0.0000	0.0000	0.0000	0.0000	0.0000	0.0000	0.0000	0.0000	0.0000	0.0000
Worker	0.0101	6.9900e-003	0.0835	2.8000e-004	0.0307	2.3000e-004	0.0309	8.1500e-003	2.2000e-004	8.3700e-003	0.0000	24.9407	24.9407	6.1000e-004	0.0000	24.9558
Total	0.0101	6.9900e-003	0.0835	2.8000e-004	0.0307	2.3000e-004	0.0309	8.1500e-003	2.2000e-004	8.3700e-003	0.0000	24.9407	24.9407	6.1000e-004	0.0000	24.9558

Mitigated Construction On-Site

	ROG	NOx	CO	SO2	Fugitive PM10	Exhaust PM10	PM10 Total	Fugitive PM2.5	Exhaust PM2.5	PM2.5 Total	Bio- CO2	NBio- CO2	Total CO2	CH4	N2O	CO2e
Category	tons/yr										MT/yr					
Archit. Coating	4.1372					0.0000	0.0000		0.0000	0.0000	0.0000	0.0000	0.0000	0.0000	0.0000	0.0000
Off-Road	3.1600e-003	0.0213	0.0317	5.0000e-005		1.0700e-003	1.0700e-003		1.0700e-003	1.0700e-003	0.0000	4.4682	4.4682	2.5000e-004	0.0000	4.4745
Total	4.1404	0.0213	0.0317	5.0000e-005		1.0700e-003	1.0700e-003		1.0700e-003	1.0700e-003	0.0000	4.4682	4.4682	2.5000e-004	0.0000	4.4745

Village South Specific Plan (Proposed) - Los Angeles-South Coast County, Annual

3.7 Architectural Coating - 2024

Mitigated Construction Off-Site

	ROG	NOx	CO	SO2	Fugitive PM10	Exhaust PM10	PM10 Total	Fugitive PM2.5	Exhaust PM2.5	PM2.5 Total	Bio- CO2	NBio- CO2	Total CO2	CH4	N2O	CO2e
Category	tons/yr										MT/yr					
Hauling	0.0000	0.0000	0.0000	0.0000	0.0000	0.0000	0.0000	0.0000	0.0000	0.0000	0.0000	0.0000	0.0000	0.0000	0.0000	0.0000
Vendor	0.0000	0.0000	0.0000	0.0000	0.0000	0.0000	0.0000	0.0000	0.0000	0.0000	0.0000	0.0000	0.0000	0.0000	0.0000	0.0000
Worker	0.0101	6.9900e-003	0.0835	2.8000e-004	0.0307	2.3000e-004	0.0309	8.1500e-003	2.2000e-004	8.3700e-003	0.0000	24.9407	24.9407	6.1000e-004	0.0000	24.9558
Total	0.0101	6.9900e-003	0.0835	2.8000e-004	0.0307	2.3000e-004	0.0309	8.1500e-003	2.2000e-004	8.3700e-003	0.0000	24.9407	24.9407	6.1000e-004	0.0000	24.9558

4.0 Operational Detail - Mobile

4.1 Mitigation Measures Mobile

Village South Specific Plan (Proposed) - Los Angeles-South Coast County, Annual

	ROG	NOx	CO	SO2	Fugitive PM10	Exhaust PM10	PM10 Total	Fugitive PM2.5	Exhaust PM2.5	PM2.5 Total	Bio- CO2	NBio- CO2	Total CO2	CH4	N2O	CO2e
Category	tons/yr										MT/yr					
Mitigated	1.5857	7.9962	19.1834	0.0821	7.7979	0.0580	7.8559	2.0895	0.0539	2.1434	0.0000	7,620.4986	7,620.4986	0.3407	0.0000	7,629.0162
Unmitigated	1.5857	7.9962	19.1834	0.0821	7.7979	0.0580	7.8559	2.0895	0.0539	2.1434	0.0000	7,620.4986	7,620.4986	0.3407	0.0000	7,629.0162

4.2 Trip Summary Information

Land Use	Average Daily Trip Rate			Unmitigated	Mitigated
	Weekday	Saturday	Sunday	Annual VMT	Annual VMT
Apartments Low Rise	145.75	154.25	154.00	506,227	506,227
Apartments Mid Rise	4,026.75	3,773.25	4075.50	13,660,065	13,660,065
General Office Building	288.45	62.55	31.05	706,812	706,812
High Turnover (Sit Down Restaurant)	2,368.80	2,873.52	2817.72	3,413,937	3,413,937
Hotel	192.00	187.50	160.00	445,703	445,703
Quality Restaurant	501.12	511.92	461.20	707,488	707,488
Regional Shopping Center	528.08	601.44	357.84	1,112,221	1,112,221
Total	8,050.95	8,164.43	8,057.31	20,552,452	20,552,452

4.3 Trip Type Information

Village South Specific Plan (Proposed) - Los Angeles-South Coast County, Annual

Land Use	Miles			Trip %			Trip Purpose %		
	H-W or C-W	H-S or C-C	H-O or C-NW	H-W or C-W	H-S or C-C	H-O or C-NW	Primary	Diverted	Pass-by
Apartments Low Rise	14.70	5.90	8.70	40.20	19.20	40.60	86	11	3
Apartments Mid Rise	14.70	5.90	8.70	40.20	19.20	40.60	86	11	3
General Office Building	16.60	8.40	6.90	33.00	48.00	19.00	77	19	4
High Turnover (Sit Down Restaurant)	16.60	8.40	6.90	8.50	72.50	19.00	37	20	43
Hotel	16.60	8.40	6.90	19.40	61.60	19.00	58	38	4
Quality Restaurant	16.60	8.40	6.90	12.00	69.00	19.00	38	18	44
Regional Shopping Center	16.60	8.40	6.90	16.30	64.70	19.00	54	35	11

4.4 Fleet Mix

Land Use	LDA	LDT1	LDT2	MDV	LHD1	LHD2	MHD	HHD	OBUS	UBUS	MCY	SBUS	MH
Apartments Low Rise	0.543088	0.044216	0.209971	0.116369	0.014033	0.006332	0.021166	0.033577	0.002613	0.001817	0.005285	0.000712	0.000821
Apartments Mid Rise	0.543088	0.044216	0.209971	0.116369	0.014033	0.006332	0.021166	0.033577	0.002613	0.001817	0.005285	0.000712	0.000821
General Office Building	0.543088	0.044216	0.209971	0.116369	0.014033	0.006332	0.021166	0.033577	0.002613	0.001817	0.005285	0.000712	0.000821
High Turnover (Sit Down Restaurant)	0.543088	0.044216	0.209971	0.116369	0.014033	0.006332	0.021166	0.033577	0.002613	0.001817	0.005285	0.000712	0.000821
Hotel	0.543088	0.044216	0.209971	0.116369	0.014033	0.006332	0.021166	0.033577	0.002613	0.001817	0.005285	0.000712	0.000821
Quality Restaurant	0.543088	0.044216	0.209971	0.116369	0.014033	0.006332	0.021166	0.033577	0.002613	0.001817	0.005285	0.000712	0.000821
Regional Shopping Center	0.543088	0.044216	0.209971	0.116369	0.014033	0.006332	0.021166	0.033577	0.002613	0.001817	0.005285	0.000712	0.000821

5.0 Energy Detail

Historical Energy Use: N

5.1 Mitigation Measures Energy

Village South Specific Plan (Proposed) - Los Angeles-South Coast County, Annual

	ROG	NOx	CO	SO2	Fugitive PM10	Exhaust PM10	PM10 Total	Fugitive PM2.5	Exhaust PM2.5	PM2.5 Total	Bio- CO2	NBio- CO2	Total CO2	CH4	N2O	CO2e	
Category	tons/yr										MT/yr						
Electricity Mitigated							0.0000	0.0000		0.0000	0.0000	0.0000	2,512.6465	2,512.6465	0.1037	0.0215	2,521.6356
Electricity Unmitigated							0.0000	0.0000		0.0000	0.0000	0.0000	2,512.6465	2,512.6465	0.1037	0.0215	2,521.6356
NaturalGas Mitigated	0.1398	1.2312	0.7770	7.6200e-003			0.0966	0.0966		0.0966	0.0966	0.0000	1,383.4267	1,383.4267	0.0265	0.0254	1,391.6478
NaturalGas Unmitigated	0.1398	1.2312	0.7770	7.6200e-003			0.0966	0.0966		0.0966	0.0966	0.0000	1,383.4267	1,383.4267	0.0265	0.0254	1,391.6478

Village South Specific Plan (Proposed) - Los Angeles-South Coast County, Annual

5.2 Energy by Land Use - NaturalGas

Unmitigated

	NaturalGas Use	ROG	NOx	CO	SO2	Fugitive PM10	Exhaust PM10	PM10 Total	Fugitive PM2.5	Exhaust PM2.5	PM2.5 Total	Bio- CO2	NBio- CO2	Total CO2	CH4	N2O	CO2e
Land Use	kBTU/yr	tons/yr										MT/yr					
Apartments Low Rise	408494	2.2000e-003	0.0188	8.0100e-003	1.2000e-004		1.5200e-003	1.5200e-003		1.5200e-003	1.5200e-003	0.0000	21.7988	21.7988	4.2000e-004	4.0000e-004	21.9284
Apartments Mid Rise	1.30613e+007	0.0704	0.6018	0.2561	3.8400e-003		0.0487	0.0487		0.0487	0.0487	0.0000	696.9989	696.9989	0.0134	0.0128	701.1408
General Office Building	468450	2.5300e-003	0.0230	0.0193	1.4000e-004		1.7500e-003	1.7500e-003		1.7500e-003	1.7500e-003	0.0000	24.9983	24.9983	4.8000e-004	4.6000e-004	25.1468
High Turnover (Sit Down Restaurant)	8.30736e+006	0.0448	0.4072	0.3421	2.4400e-003		0.0310	0.0310		0.0310	0.0310	0.0000	443.3124	443.3124	8.5000e-003	8.1300e-003	445.9468
Hotel	1.74095e+006	9.3900e-003	0.0853	0.0717	5.1000e-004		6.4900e-003	6.4900e-003		6.4900e-003	6.4900e-003	0.0000	92.9036	92.9036	1.7800e-003	1.7000e-003	93.4557
Quality Restaurant	1.84608e+006	9.9500e-003	0.0905	0.0760	5.4000e-004		6.8800e-003	6.8800e-003		6.8800e-003	6.8800e-003	0.0000	98.5139	98.5139	1.8900e-003	1.8100e-003	99.0993
Regional Shopping Center	91840	5.0000e-004	4.5000e-003	3.7800e-003	3.0000e-005		3.4000e-004	3.4000e-004		3.4000e-004	3.4000e-004	0.0000	4.9009	4.9009	9.0000e-005	9.0000e-005	4.9301
Total		0.1398	1.2312	0.7770	7.6200e-003		0.0966	0.0966		0.0966	0.0966	0.0000	1,383.4268	1,383.4268	0.0265	0.0254	1,391.6478

Village South Specific Plan (Proposed) - Los Angeles-South Coast County, Annual

5.2 Energy by Land Use - NaturalGas

Mitigated

	NaturalGas Use	ROG	NOx	CO	SO2	Fugitive PM10	Exhaust PM10	PM10 Total	Fugitive PM2.5	Exhaust PM2.5	PM2.5 Total	Bio- CO2	NBio- CO2	Total CO2	CH4	N2O	CO2e
Land Use	kBTU/yr	tons/yr										MT/yr					
Apartments Low Rise	408494	2.2000e-003	0.0188	8.0100e-003	1.2000e-004		1.5200e-003	1.5200e-003		1.5200e-003	1.5200e-003	0.0000	21.7988	21.7988	4.2000e-004	4.0000e-004	21.9284
Apartments Mid Rise	1.30613e+007	0.0704	0.6018	0.2561	3.8400e-003		0.0487	0.0487		0.0487	0.0487	0.0000	696.9989	696.9989	0.0134	0.0128	701.1408
General Office Building	468450	2.5300e-003	0.0230	0.0193	1.4000e-004		1.7500e-003	1.7500e-003		1.7500e-003	1.7500e-003	0.0000	24.9983	24.9983	4.8000e-004	4.6000e-004	25.1468
High Turnover (Sit Down Restaurant)	8.30736e+006	0.0448	0.4072	0.3421	2.4400e-003		0.0310	0.0310		0.0310	0.0310	0.0000	443.3124	443.3124	8.5000e-003	8.1300e-003	445.9468
Hotel	1.74095e+006	9.3900e-003	0.0853	0.0717	5.1000e-004		6.4900e-003	6.4900e-003		6.4900e-003	6.4900e-003	0.0000	92.9036	92.9036	1.7800e-003	1.7000e-003	93.4557
Quality Restaurant	1.84608e+006	9.9500e-003	0.0905	0.0760	5.4000e-004		6.8800e-003	6.8800e-003		6.8800e-003	6.8800e-003	0.0000	98.5139	98.5139	1.8900e-003	1.8100e-003	99.0993
Regional Shopping Center	91840	5.0000e-004	4.5000e-003	3.7800e-003	3.0000e-005		3.4000e-004	3.4000e-004		3.4000e-004	3.4000e-004	0.0000	4.9009	4.9009	9.0000e-005	9.0000e-005	4.9301
Total		0.1398	1.2312	0.7770	7.6200e-003		0.0966	0.0966		0.0966	0.0966	0.0000	1,383.4268	1,383.4268	0.0265	0.0254	1,391.6478

Village South Specific Plan (Proposed) - Los Angeles-South Coast County, Annual

5.3 Energy by Land Use - Electricity

Unmitigated

	Electricity Use	Total CO2	CH4	N2O	CO2e
Land Use	kWh/yr	MT/yr			
Apartments Low Rise	106010	33.7770	1.3900e-003	2.9000e-004	33.8978
Apartments Mid Rise	3.94697e+006	1,257.5879	0.0519	0.0107	1,262.0869
General Office Building	584550	186.2502	7.6900e-003	1.5900e-003	186.9165
High Turnover (Sit Down Restaurant)	1.58904e+006	506.3022	0.0209	4.3200e-003	508.1135
Hotel	550308	175.3399	7.2400e-003	1.5000e-003	175.9672
Quality Restaurant	353120	112.5116	4.6500e-003	9.6000e-004	112.9141
Regional Shopping Center	756000	240.8778	9.9400e-003	2.0600e-003	241.7395
Total		2,512.6465	0.1037	0.0215	2,521.6356

Village South Specific Plan (Proposed) - Los Angeles-South Coast County, Annual

5.3 Energy by Land Use - Electricity

Mitigated

	Electricity Use	Total CO2	CH4	N2O	CO2e
Land Use	kWh/yr	MT/yr			
Apartments Low Rise	106010	33.7770	1.3900e-003	2.9000e-004	33.8978
Apartments Mid Rise	3.94697e+006	1,257.5879	0.0519	0.0107	1,262.0869
General Office Building	584550	186.2502	7.6900e-003	1.5900e-003	186.9165
High Turnover (Sit Down Restaurant)	1.58904e+006	506.3022	0.0209	4.3200e-003	508.1135
Hotel	550308	175.3399	7.2400e-003	1.5000e-003	175.9672
Quality Restaurant	353120	112.5116	4.6500e-003	9.6000e-004	112.9141
Regional Shopping Center	756000	240.8778	9.9400e-003	2.0600e-003	241.7395
Total		2,512.6465	0.1037	0.0215	2,521.6356

6.0 Area Detail

6.1 Mitigation Measures Area

Village South Specific Plan (Proposed) - Los Angeles-South Coast County, Annual

	ROG	NOx	CO	SO2	Fugitive PM10	Exhaust PM10	PM10 Total	Fugitive PM2.5	Exhaust PM2.5	PM2.5 Total	Bio- CO2	NBio- CO2	Total CO2	CH4	N2O	CO2e
Category	tons/yr										MT/yr					
Mitigated	5.1437	0.2950	10.3804	1.6700e-003		0.0714	0.0714		0.0714	0.0714	0.0000	220.9670	220.9670	0.0201	3.7400e-003	222.5835
Unmitigated	5.1437	0.2950	10.3804	1.6700e-003		0.0714	0.0714		0.0714	0.0714	0.0000	220.9670	220.9670	0.0201	3.7400e-003	222.5835

6.2 Area by SubCategory

Unmitigated

	ROG	NOx	CO	SO2	Fugitive PM10	Exhaust PM10	PM10 Total	Fugitive PM2.5	Exhaust PM2.5	PM2.5 Total	Bio- CO2	NBio- CO2	Total CO2	CH4	N2O	CO2e
SubCategory	tons/yr										MT/yr					
Architectural Coating	0.4137					0.0000	0.0000		0.0000	0.0000	0.0000	0.0000	0.0000	0.0000	0.0000	0.0000
Consumer Products	4.3998					0.0000	0.0000		0.0000	0.0000	0.0000	0.0000	0.0000	0.0000	0.0000	0.0000
Hearth	0.0206	0.1763	0.0750	1.1200e-003		0.0143	0.0143		0.0143	0.0143	0.0000	204.1166	204.1166	3.9100e-003	3.7400e-003	205.3295
Landscaping	0.3096	0.1187	10.3054	5.4000e-004		0.0572	0.0572		0.0572	0.0572	0.0000	16.8504	16.8504	0.0161	0.0000	17.2540
Total	5.1437	0.2950	10.3804	1.6600e-003		0.0714	0.0714		0.0714	0.0714	0.0000	220.9670	220.9670	0.0201	3.7400e-003	222.5835

Village South Specific Plan (Proposed) - Los Angeles-South Coast County, Annual

6.2 Area by SubCategory

Mitigated

	ROG	NOx	CO	SO2	Fugitive PM10	Exhaust PM10	PM10 Total	Fugitive PM2.5	Exhaust PM2.5	PM2.5 Total	Bio- CO2	NBio- CO2	Total CO2	CH4	N2O	CO2e
SubCategory	tons/yr										MT/yr					
Architectural Coating	0.4137					0.0000	0.0000		0.0000	0.0000	0.0000	0.0000	0.0000	0.0000	0.0000	0.0000
Consumer Products	4.3998					0.0000	0.0000		0.0000	0.0000	0.0000	0.0000	0.0000	0.0000	0.0000	0.0000
Hearth	0.0206	0.1763	0.0750	1.1200e-003		0.0143	0.0143		0.0143	0.0143	0.0000	204.1166	204.1166	3.9100e-003	3.7400e-003	205.3295
Landscaping	0.3096	0.1187	10.3054	5.4000e-004		0.0572	0.0572		0.0572	0.0572	0.0000	16.8504	16.8504	0.0161	0.0000	17.2540
Total	5.1437	0.2950	10.3804	1.6600e-003		0.0714	0.0714		0.0714	0.0714	0.0000	220.9670	220.9670	0.0201	3.7400e-003	222.5835

7.0 Water Detail

7.1 Mitigation Measures Water

Village South Specific Plan (Proposed) - Los Angeles-South Coast County, Annual

	Total CO2	CH4	N2O	CO2e
Category	MT/yr			
Mitigated	585.8052	3.0183	0.0755	683.7567
Unmitigated	585.8052	3.0183	0.0755	683.7567

Village South Specific Plan (Proposed) - Los Angeles-South Coast County, Annual

7.2 Water by Land Use

Unmitigated

	Indoor/Outdoor Use	Total CO2	CH4	N2O	CO2e
Land Use	Mgal	MT/yr			
Apartments Low Rise	1.62885 / 1.02688	10.9095	0.0535	1.3400e-003	12.6471
Apartments Mid Rise	63.5252 / 40.0485	425.4719	2.0867	0.0523	493.2363
General Office Building	7.99802 / 4.90201	53.0719	0.2627	6.5900e-003	61.6019
High Turnover (Sit Down Restaurant)	10.9272 / 0.697482	51.2702	0.3580	8.8200e-003	62.8482
Hotel	1.26834 / 0.140927	6.1633	0.0416	1.0300e-003	7.5079
Quality Restaurant	2.42827 / 0.154996	11.3934	0.0796	1.9600e-003	13.9663
Regional Shopping Center	4.14806 / 2.54236	27.5250	0.1363	3.4200e-003	31.9490
Total		585.8052	3.0183	0.0755	683.7567

Village South Specific Plan (Proposed) - Los Angeles-South Coast County, Annual

7.2 Water by Land Use

Mitigated

	Indoor/Outdoor Use	Total CO2	CH4	N2O	CO2e
Land Use	Mgal	MT/yr			
Apartments Low Rise	1.62885 / 1.02688	10.9095	0.0535	1.3400e-003	12.6471
Apartments Mid Rise	63.5252 / 40.0485	425.4719	2.0867	0.0523	493.2363
General Office Building	7.99802 / 4.90201	53.0719	0.2627	6.5900e-003	61.6019
High Turnover (Sit Down Restaurant)	10.9272 / 0.697482	51.2702	0.3580	8.8200e-003	62.8482
Hotel	1.26834 / 0.140927	6.1633	0.0416	1.0300e-003	7.5079
Quality Restaurant	2.42827 / 0.154996	11.3934	0.0796	1.9600e-003	13.9663
Regional Shopping Center	4.14806 / 2.54236	27.5250	0.1363	3.4200e-003	31.9490
Total		585.8052	3.0183	0.0755	683.7567

8.0 Waste Detail

8.1 Mitigation Measures Waste

Village South Specific Plan (Proposed) - Los Angeles-South Coast County, Annual

Category/Year

	Total CO2	CH4	N2O	CO2e
	MT/yr			
Mitigated	207.8079	12.2811	0.0000	514.8354
Unmitigated	207.8079	12.2811	0.0000	514.8354

Village South Specific Plan (Proposed) - Los Angeles-South Coast County, Annual

8.2 Waste by Land Use

Unmitigated

	Waste Disposed	Total CO2	CH4	N2O	CO2e
Land Use	tons	MT/yr			
Apartments Low Rise	11.5	2.3344	0.1380	0.0000	5.7834
Apartments Mid Rise	448.5	91.0415	5.3804	0.0000	225.5513
General Office Building	41.85	8.4952	0.5021	0.0000	21.0464
High Turnover (Sit Down Restaurant)	428.4	86.9613	5.1393	0.0000	215.4430
Hotel	27.38	5.5579	0.3285	0.0000	13.7694
Quality Restaurant	7.3	1.4818	0.0876	0.0000	3.6712
Regional Shopping Center	58.8	11.9359	0.7054	0.0000	29.5706
Total		207.8079	12.2811	0.0000	514.8354

Village South Specific Plan (Proposed) - Los Angeles-South Coast County, Annual

8.2 Waste by Land Use

Mitigated

	Waste Disposed	Total CO2	CH4	N2O	CO2e
Land Use	tons	MT/yr			
Apartments Low Rise	11.5	2.3344	0.1380	0.0000	5.7834
Apartments Mid Rise	448.5	91.0415	5.3804	0.0000	225.5513
General Office Building	41.85	8.4952	0.5021	0.0000	21.0464
High Turnover (Sit Down Restaurant)	428.4	86.9613	5.1393	0.0000	215.4430
Hotel	27.38	5.5579	0.3285	0.0000	13.7694
Quality Restaurant	7.3	1.4818	0.0876	0.0000	3.6712
Regional Shopping Center	58.8	11.9359	0.7054	0.0000	29.5706
Total		207.8079	12.2811	0.0000	514.8354

9.0 Operational Offroad

Equipment Type	Number	Hours/Day	Days/Year	Horse Power	Load Factor	Fuel Type
----------------	--------	-----------	-----------	-------------	-------------	-----------

10.0 Stationary Equipment

Fire Pumps and Emergency Generators

Equipment Type	Number	Hours/Day	Hours/Year	Horse Power	Load Factor	Fuel Type
----------------	--------	-----------	------------	-------------	-------------	-----------

Village South Specific Plan (Proposed) - Los Angeles-South Coast County, Annual

Boilers

Equipment Type	Number	Heat Input/Day	Heat Input/Year	Boiler Rating	Fuel Type
----------------	--------	----------------	-----------------	---------------	-----------

User Defined Equipment

Equipment Type	Number
----------------	--------

11.0 Vegetation

Village South Specific Plan (Proposed) - Los Angeles-South Coast County, Summer

Village South Specific Plan (Proposed)
Los Angeles-South Coast County, Summer

1.0 Project Characteristics

1.1 Land Usage

Land Uses	Size	Metric	Lot Acreage	Floor Surface Area	Population
General Office Building	45.00	1000sqft	1.03	45,000.00	0
High Turnover (Sit Down Restaurant)	36.00	1000sqft	0.83	36,000.00	0
Hotel	50.00	Room	1.67	72,600.00	0
Quality Restaurant	8.00	1000sqft	0.18	8,000.00	0
Apartments Low Rise	25.00	Dwelling Unit	1.56	25,000.00	72
Apartments Mid Rise	975.00	Dwelling Unit	25.66	975,000.00	2789
Regional Shopping Center	56.00	1000sqft	1.29	56,000.00	0

1.2 Other Project Characteristics

Urbanization	Urban	Wind Speed (m/s)	2.2	Precipitation Freq (Days)	33
Climate Zone	9			Operational Year	2028
Utility Company	Southern California Edison				
CO2 Intensity (lb/MW hr)	702.44	CH4 Intensity (lb/MW hr)	0.029	N2O Intensity (lb/MW hr)	0.006

1.3 User Entered Comments & Non-Default Data

Village South Specific Plan (Proposed) - Los Angeles-South Coast County, Summer

Project Characteristics - Consistent with the DEIR's model.

Land Use - See SWAPE comment regarding residential and retail land uses.

Construction Phase - See SWAPE comment regarding individual construction phase lengths.

Demolition - Consistent with the DEIR's model. See SWAPE comment regarding demolition.

Vehicle Trips - Saturday trips consistent with the DEIR's model. See SWAPE comment regarding weekday and Sunday trips.

Woodstoves - Woodstoves and wood-burning fireplaces consistent with the DEIR's model. See SWAPE comment regarding gas fireplaces.

Energy Use -

Construction Off-road Equipment Mitigation - See SWAPE comment on construction-related mitigation.

Area Mitigation - See SWAPE comment regarding operational mitigation measures.

Water Mitigation - See SWAPE comment regarding operational mitigation measures.

Table Name	Column Name	Default Value	New Value
tblFireplaces	FireplaceWoodMass	1,019.20	0.00
tblFireplaces	FireplaceWoodMass	1,019.20	0.00
tblFireplaces	NumberWood	1.25	0.00
tblFireplaces	NumberWood	48.75	0.00
tblVehicleTrips	ST_TR	7.16	6.17
tblVehicleTrips	ST_TR	6.39	3.87
tblVehicleTrips	ST_TR	2.46	1.39
tblVehicleTrips	ST_TR	158.37	79.82
tblVehicleTrips	ST_TR	8.19	3.75
tblVehicleTrips	ST_TR	94.36	63.99
tblVehicleTrips	ST_TR	49.97	10.74
tblVehicleTrips	SU_TR	6.07	6.16
tblVehicleTrips	SU_TR	5.86	4.18
tblVehicleTrips	SU_TR	1.05	0.69
tblVehicleTrips	SU_TR	131.84	78.27

Village South Specific Plan (Proposed) - Los Angeles-South Coast County, Summer

tblVehicleTrips	SU_TR	5.95	3.20
tblVehicleTrips	SU_TR	72.16	57.65
tblVehicleTrips	SU_TR	25.24	6.39
tblVehicleTrips	WD_TR	6.59	5.83
tblVehicleTrips	WD_TR	6.65	4.13
tblVehicleTrips	WD_TR	11.03	6.41
tblVehicleTrips	WD_TR	127.15	65.80
tblVehicleTrips	WD_TR	8.17	3.84
tblVehicleTrips	WD_TR	89.95	62.64
tblVehicleTrips	WD_TR	42.70	9.43
tblWoodstoves	NumberCatalytic	1.25	0.00
tblWoodstoves	NumberCatalytic	48.75	0.00
tblWoodstoves	NumberNoncatalytic	1.25	0.00
tblWoodstoves	NumberNoncatalytic	48.75	0.00
tblWoodstoves	WoodstoveDayYear	25.00	0.00
tblWoodstoves	WoodstoveDayYear	25.00	0.00
tblWoodstoves	WoodstoveWoodMass	999.60	0.00
tblWoodstoves	WoodstoveWoodMass	999.60	0.00

2.0 Emissions Summary

Village South Specific Plan (Proposed) - Los Angeles-South Coast County, Summer

2.1 Overall Construction (Maximum Daily Emission)

Unmitigated Construction

	ROG	NOx	CO	SO2	Fugitive PM10	Exhaust PM10	PM10 Total	Fugitive PM2.5	Exhaust PM2.5	PM2.5 Total	Bio- CO2	NBio- CO2	Total CO2	CH4	N2O	CO2e
Year	lb/day										lb/day					
2021	4.2769	46.4588	31.6840	0.0643	18.2675	2.0461	20.3135	9.9840	1.8824	11.8664	0.0000	6,234.7974	6,234.7974	1.9495	0.0000	6,283.5352
2022	5.3304	38.8967	49.5629	0.1517	9.8688	1.6366	10.7727	3.6558	1.5057	5.1615	0.0000	15,251.5674	15,251.5674	1.9503	0.0000	15,278.5288
2023	4.8957	26.3317	46.7567	0.1472	9.8688	0.7794	10.6482	2.6381	0.7322	3.3702	0.0000	14,807.5269	14,807.5269	1.0250	0.0000	14,833.1521
2024	237.1630	9.5575	15.1043	0.0244	1.7884	0.4698	1.8628	0.4743	0.4322	0.5476	0.0000	2,361.3989	2,361.3989	0.7177	0.0000	2,379.3421
Maximum	237.1630	46.4588	49.5629	0.1517	18.2675	2.0461	20.3135	9.9840	1.8824	11.8664	0.0000	15,251.5674	15,251.5674	1.9503	0.0000	15,278.5288

Village South Specific Plan (Proposed) - Los Angeles-South Coast County, Summer

2.2 Overall Operational

Unmitigated Operational

	ROG	NOx	CO	SO2	Fugitive PM10	Exhaust PM10	PM10 Total	Fugitive PM2.5	Exhaust PM2.5	PM2.5 Total	Bio- CO2	NBio- CO2	Total CO2	CH4	N2O	CO2e
Category	lb/day										lb/day					
Area	30.5020	15.0496	88.4430	0.0944		1.5974	1.5974		1.5974	1.5974	0.0000	18,148.59 50	18,148.59 50	0.4874	0.3300	18,259.11 92
Energy	0.7660	6.7462	4.2573	0.0418		0.5292	0.5292		0.5292	0.5292		8,355.983 2	8,355.983 2	0.1602	0.1532	8,405.638 7
Mobile	9.8489	45.4304	114.8495	0.4917	45.9592	0.3360	46.2951	12.2950	0.3119	12.6070		50,306.60 34	50,306.60 34	2.1807		50,361.12 08
Total	41.1168	67.2262	207.5497	0.6278	45.9592	2.4626	48.4217	12.2950	2.4385	14.7336	0.0000	76,811.18 16	76,811.18 16	2.8282	0.4832	77,025.87 86

Mitigated Operational

	ROG	NOx	CO	SO2	Fugitive PM10	Exhaust PM10	PM10 Total	Fugitive PM2.5	Exhaust PM2.5	PM2.5 Total	Bio- CO2	NBio- CO2	Total CO2	CH4	N2O	CO2e
Category	lb/day										lb/day					
Area	30.5020	15.0496	88.4430	0.0944		1.5974	1.5974		1.5974	1.5974	0.0000	18,148.59 50	18,148.59 50	0.4874	0.3300	18,259.11 92
Energy	0.7660	6.7462	4.2573	0.0418		0.5292	0.5292		0.5292	0.5292		8,355.983 2	8,355.983 2	0.1602	0.1532	8,405.638 7
Mobile	9.8489	45.4304	114.8495	0.4917	45.9592	0.3360	46.2951	12.2950	0.3119	12.6070		50,306.60 34	50,306.60 34	2.1807		50,361.12 08
Total	41.1168	67.2262	207.5497	0.6278	45.9592	2.4626	48.4217	12.2950	2.4385	14.7336	0.0000	76,811.18 16	76,811.18 16	2.8282	0.4832	77,025.87 86

Village South Specific Plan (Proposed) - Los Angeles-South Coast County, Summer

	ROG	NOx	CO	SO2	Fugitive PM10	Exhaust PM10	PM10 Total	Fugitive PM2.5	Exhaust PM2.5	PM2.5 Total	Bio- CO2	NBio-CO2	Total CO2	CH4	N2O	CO2e
Percent Reduction	0.00	0.00	0.00	0.00	0.00	0.00	0.00	0.00	0.00	0.00	0.00	0.00	0.00	0.00	0.00	0.00

3.0 Construction Detail

Construction Phase

Phase Number	Phase Name	Phase Type	Start Date	End Date	Num Days Week	Num Days	Phase Description
1	Demolition	Demolition	9/1/2021	10/12/2021	5	30	
2	Site Preparation	Site Preparation	10/13/2021	11/9/2021	5	20	
3	Grading	Grading	11/10/2021	1/11/2022	5	45	
4	Building Construction	Building Construction	1/12/2022	12/12/2023	5	500	
5	Paving	Paving	12/13/2023	1/30/2024	5	35	
6	Architectural Coating	Architectural Coating	1/31/2024	3/19/2024	5	35	

Acres of Grading (Site Preparation Phase): 0

Acres of Grading (Grading Phase): 112.5

Acres of Paving: 0

Residential Indoor: 2,025,000; Residential Outdoor: 675,000; Non-Residential Indoor: 326,400; Non-Residential Outdoor: 108,800; Striped Parking Area: 0 (Architectural Coating – sqft)

OffRoad Equipment

Village South Specific Plan (Proposed) - Los Angeles-South Coast County, Summer

Phase Name	Offroad Equipment Type	Amount	Usage Hours	Horse Power	Load Factor
Demolition	Concrete/Industrial Saws	1	8.00	81	0.73
Demolition	Excavators	3	8.00	158	0.38
Demolition	Rubber Tired Dozers	2	8.00	247	0.40
Site Preparation	Rubber Tired Dozers	3	8.00	247	0.40
Site Preparation	Tractors/Loaders/Backhoes	4	8.00	97	0.37
Grading	Excavators	2	8.00	158	0.38
Grading	Graders	1	8.00	187	0.41
Grading	Rubber Tired Dozers	1	8.00	247	0.40
Grading	Scrapers	2	8.00	367	0.48
Grading	Tractors/Loaders/Backhoes	2	8.00	97	0.37
Building Construction	Cranes	1	7.00	231	0.29
Building Construction	Forklifts	3	8.00	89	0.20
Building Construction	Generator Sets	1	8.00	84	0.74
Building Construction	Tractors/Loaders/Backhoes	3	7.00	97	0.37
Building Construction	Welders	1	8.00	46	0.45
Paving	Pavers	2	8.00	130	0.42
Paving	Paving Equipment	2	8.00	132	0.36
Paving	Rollers	2	8.00	80	0.38
Architectural Coating	Air Compressors	1	6.00	78	0.48

Trips and VMT

Village South Specific Plan (Proposed) - Los Angeles-South Coast County, Summer

Phase Name	Offroad Equipment Count	Worker Trip Number	Vendor Trip Number	Hauling Trip Number	Worker Trip Length	Vendor Trip Length	Hauling Trip Length	Worker Vehicle Class	Vendor Vehicle Class	Hauling Vehicle Class
Demolition	6	15.00	0.00	458.00	14.70	6.90	20.00	LD_Mix	HDT_Mix	HHDT
Site Preparation	7	18.00	0.00	0.00	14.70	6.90	20.00	LD_Mix	HDT_Mix	HHDT
Grading	8	20.00	0.00	0.00	14.70	6.90	20.00	LD_Mix	HDT_Mix	HHDT
Building Construction	9	801.00	143.00	0.00	14.70	6.90	20.00	LD_Mix	HDT_Mix	HHDT
Paving	6	15.00	0.00	0.00	14.70	6.90	20.00	LD_Mix	HDT_Mix	HHDT
Architectural Coating	1	160.00	0.00	0.00	14.70	6.90	20.00	LD_Mix	HDT_Mix	HHDT

3.1 Mitigation Measures Construction

3.2 Demolition - 2021

Unmitigated Construction On-Site

	ROG	NOx	CO	SO2	Fugitive PM10	Exhaust PM10	PM10 Total	Fugitive PM2.5	Exhaust PM2.5	PM2.5 Total	Bio- CO2	NBio- CO2	Total CO2	CH4	N2O	CO2e
Category	lb/day										lb/day					
Fugitive Dust					3.3074	0.0000	3.3074	0.5008	0.0000	0.5008			0.0000			0.0000
Off-Road	3.1651	31.4407	21.5650	0.0388		1.5513	1.5513		1.4411	1.4411		3,747.9449	3,747.9449	1.0549		3,774.3174
Total	3.1651	31.4407	21.5650	0.0388	3.3074	1.5513	4.8588	0.5008	1.4411	1.9419		3,747.9449	3,747.9449	1.0549		3,774.3174

Village South Specific Plan (Proposed) - Los Angeles-South Coast County, Summer

3.2 Demolition - 2021

Unmitigated Construction Off-Site

	ROG	NOx	CO	SO2	Fugitive PM10	Exhaust PM10	PM10 Total	Fugitive PM2.5	Exhaust PM2.5	PM2.5 Total	Bio- CO2	NBio- CO2	Total CO2	CH4	N2O	CO2e
Category	lb/day										lb/day					
Hauling	0.1273	4.0952	0.9602	0.0119	0.2669	0.0126	0.2795	0.0732	0.0120	0.0852		1,292.2413	1,292.2413	0.0877		1,294.4337
Vendor	0.0000	0.0000	0.0000	0.0000	0.0000	0.0000	0.0000	0.0000	0.0000	0.0000		0.0000	0.0000	0.0000		0.0000
Worker	0.0643	0.0442	0.6042	1.7100e-003	0.1677	1.3500e-003	0.1690	0.0445	1.2500e-003	0.0457		170.8155	170.8155	5.0300e-003		170.9413
Total	0.1916	4.1394	1.5644	0.0136	0.4346	0.0139	0.4485	0.1176	0.0133	0.1309		1,463.0568	1,463.0568	0.0927		1,465.3750

Mitigated Construction On-Site

	ROG	NOx	CO	SO2	Fugitive PM10	Exhaust PM10	PM10 Total	Fugitive PM2.5	Exhaust PM2.5	PM2.5 Total	Bio- CO2	NBio- CO2	Total CO2	CH4	N2O	CO2e
Category	lb/day										lb/day					
Fugitive Dust					3.3074	0.0000	3.3074	0.5008	0.0000	0.5008			0.0000			0.0000
Off-Road	3.1651	31.4407	21.5650	0.0388		1.5513	1.5513		1.4411	1.4411	0.0000	3,747.9449	3,747.9449	1.0549		3,774.3174
Total	3.1651	31.4407	21.5650	0.0388	3.3074	1.5513	4.8588	0.5008	1.4411	1.9419	0.0000	3,747.9449	3,747.9449	1.0549		3,774.3174

Village South Specific Plan (Proposed) - Los Angeles-South Coast County, Summer

3.2 Demolition - 2021

Mitigated Construction Off-Site

	ROG	NOx	CO	SO2	Fugitive PM10	Exhaust PM10	PM10 Total	Fugitive PM2.5	Exhaust PM2.5	PM2.5 Total	Bio- CO2	NBio- CO2	Total CO2	CH4	N2O	CO2e
Category	lb/day										lb/day					
Hauling	0.1273	4.0952	0.9602	0.0119	0.2669	0.0126	0.2795	0.0732	0.0120	0.0852		1,292.2413	1,292.2413	0.0877		1,294.4337
Vendor	0.0000	0.0000	0.0000	0.0000	0.0000	0.0000	0.0000	0.0000	0.0000	0.0000		0.0000	0.0000	0.0000		0.0000
Worker	0.0643	0.0442	0.6042	1.7100e-003	0.1677	1.3500e-003	0.1690	0.0445	1.2500e-003	0.0457		170.8155	170.8155	5.0300e-003		170.9413
Total	0.1916	4.1394	1.5644	0.0136	0.4346	0.0139	0.4485	0.1176	0.0133	0.1309		1,463.0568	1,463.0568	0.0927		1,465.3750

3.3 Site Preparation - 2021

Unmitigated Construction On-Site

	ROG	NOx	CO	SO2	Fugitive PM10	Exhaust PM10	PM10 Total	Fugitive PM2.5	Exhaust PM2.5	PM2.5 Total	Bio- CO2	NBio- CO2	Total CO2	CH4	N2O	CO2e
Category	lb/day										lb/day					
Fugitive Dust					18.0663	0.0000	18.0663	9.9307	0.0000	9.9307			0.0000			0.0000
Off-Road	3.8882	40.4971	21.1543	0.0380		2.0445	2.0445		1.8809	1.8809		3,685.6569	3,685.6569	1.1920		3,715.4573
Total	3.8882	40.4971	21.1543	0.0380	18.0663	2.0445	20.1107	9.9307	1.8809	11.8116		3,685.6569	3,685.6569	1.1920		3,715.4573

Village South Specific Plan (Proposed) - Los Angeles-South Coast County, Summer

3.3 Site Preparation - 2021

Unmitigated Construction Off-Site

	ROG	NOx	CO	SO2	Fugitive PM10	Exhaust PM10	PM10 Total	Fugitive PM2.5	Exhaust PM2.5	PM2.5 Total	Bio- CO2	NBio- CO2	Total CO2	CH4	N2O	CO2e
Category	lb/day										lb/day					
Hauling	0.0000	0.0000	0.0000	0.0000	0.0000	0.0000	0.0000	0.0000	0.0000	0.0000		0.0000	0.0000	0.0000		0.0000
Vendor	0.0000	0.0000	0.0000	0.0000	0.0000	0.0000	0.0000	0.0000	0.0000	0.0000		0.0000	0.0000	0.0000		0.0000
Worker	0.0772	0.0530	0.7250	2.0600e-003	0.2012	1.6300e-003	0.2028	0.0534	1.5000e-003	0.0549		204.9786	204.9786	6.0400e-003		205.1296
Total	0.0772	0.0530	0.7250	2.0600e-003	0.2012	1.6300e-003	0.2028	0.0534	1.5000e-003	0.0549		204.9786	204.9786	6.0400e-003		205.1296

Mitigated Construction On-Site

	ROG	NOx	CO	SO2	Fugitive PM10	Exhaust PM10	PM10 Total	Fugitive PM2.5	Exhaust PM2.5	PM2.5 Total	Bio- CO2	NBio- CO2	Total CO2	CH4	N2O	CO2e
Category	lb/day										lb/day					
Fugitive Dust					18.0663	0.0000	18.0663	9.9307	0.0000	9.9307			0.0000			0.0000
Off-Road	3.8882	40.4971	21.1543	0.0380		2.0445	2.0445		1.8809	1.8809	0.0000	3,685.6569	3,685.6569	1.1920		3,715.4573
Total	3.8882	40.4971	21.1543	0.0380	18.0663	2.0445	20.1107	9.9307	1.8809	11.8116	0.0000	3,685.6569	3,685.6569	1.1920		3,715.4573

Village South Specific Plan (Proposed) - Los Angeles-South Coast County, Summer

3.3 Site Preparation - 2021

Mitigated Construction Off-Site

	ROG	NOx	CO	SO2	Fugitive PM10	Exhaust PM10	PM10 Total	Fugitive PM2.5	Exhaust PM2.5	PM2.5 Total	Bio- CO2	NBio- CO2	Total CO2	CH4	N2O	CO2e
Category	lb/day										lb/day					
Hauling	0.0000	0.0000	0.0000	0.0000	0.0000	0.0000	0.0000	0.0000	0.0000	0.0000		0.0000	0.0000	0.0000		0.0000
Vendor	0.0000	0.0000	0.0000	0.0000	0.0000	0.0000	0.0000	0.0000	0.0000	0.0000		0.0000	0.0000	0.0000		0.0000
Worker	0.0772	0.0530	0.7250	2.0600e-003	0.2012	1.6300e-003	0.2028	0.0534	1.5000e-003	0.0549		204.9786	204.9786	6.0400e-003		205.1296
Total	0.0772	0.0530	0.7250	2.0600e-003	0.2012	1.6300e-003	0.2028	0.0534	1.5000e-003	0.0549		204.9786	204.9786	6.0400e-003		205.1296

3.4 Grading - 2021

Unmitigated Construction On-Site

	ROG	NOx	CO	SO2	Fugitive PM10	Exhaust PM10	PM10 Total	Fugitive PM2.5	Exhaust PM2.5	PM2.5 Total	Bio- CO2	NBio- CO2	Total CO2	CH4	N2O	CO2e
Category	lb/day										lb/day					
Fugitive Dust					8.6733	0.0000	8.6733	3.5965	0.0000	3.5965			0.0000			0.0000
Off-Road	4.1912	46.3998	30.8785	0.0620		1.9853	1.9853		1.8265	1.8265		6,007.0434	6,007.0434	1.9428		6,055.6134
Total	4.1912	46.3998	30.8785	0.0620	8.6733	1.9853	10.6587	3.5965	1.8265	5.4230		6,007.0434	6,007.0434	1.9428		6,055.6134

Village South Specific Plan (Proposed) - Los Angeles-South Coast County, Summer

3.4 Grading - 2021

Unmitigated Construction Off-Site

	ROG	NOx	CO	SO2	Fugitive PM10	Exhaust PM10	PM10 Total	Fugitive PM2.5	Exhaust PM2.5	PM2.5 Total	Bio- CO2	NBio- CO2	Total CO2	CH4	N2O	CO2e
Category	lb/day										lb/day					
Hauling	0.0000	0.0000	0.0000	0.0000	0.0000	0.0000	0.0000	0.0000	0.0000	0.0000		0.0000	0.0000	0.0000		0.0000
Vendor	0.0000	0.0000	0.0000	0.0000	0.0000	0.0000	0.0000	0.0000	0.0000	0.0000		0.0000	0.0000	0.0000		0.0000
Worker	0.0857	0.0589	0.8056	2.2900e-003	0.2236	1.8100e-003	0.2254	0.0593	1.6600e-003	0.0610		227.7540	227.7540	6.7100e-003		227.9217
Total	0.0857	0.0589	0.8056	2.2900e-003	0.2236	1.8100e-003	0.2254	0.0593	1.6600e-003	0.0610		227.7540	227.7540	6.7100e-003		227.9217

Mitigated Construction On-Site

	ROG	NOx	CO	SO2	Fugitive PM10	Exhaust PM10	PM10 Total	Fugitive PM2.5	Exhaust PM2.5	PM2.5 Total	Bio- CO2	NBio- CO2	Total CO2	CH4	N2O	CO2e
Category	lb/day										lb/day					
Fugitive Dust					8.6733	0.0000	8.6733	3.5965	0.0000	3.5965			0.0000			0.0000
Off-Road	4.1912	46.3998	30.8785	0.0620		1.9853	1.9853		1.8265	1.8265	0.0000	6,007.0434	6,007.0434	1.9428		6,055.6134
Total	4.1912	46.3998	30.8785	0.0620	8.6733	1.9853	10.6587	3.5965	1.8265	5.4230	0.0000	6,007.0434	6,007.0434	1.9428		6,055.6134

Village South Specific Plan (Proposed) - Los Angeles-South Coast County, Summer

3.4 Grading - 2021

Mitigated Construction Off-Site

	ROG	NOx	CO	SO2	Fugitive PM10	Exhaust PM10	PM10 Total	Fugitive PM2.5	Exhaust PM2.5	PM2.5 Total	Bio- CO2	NBio- CO2	Total CO2	CH4	N2O	CO2e
Category	lb/day										lb/day					
Hauling	0.0000	0.0000	0.0000	0.0000	0.0000	0.0000	0.0000	0.0000	0.0000	0.0000		0.0000	0.0000	0.0000		0.0000
Vendor	0.0000	0.0000	0.0000	0.0000	0.0000	0.0000	0.0000	0.0000	0.0000	0.0000		0.0000	0.0000	0.0000		0.0000
Worker	0.0857	0.0589	0.8056	2.2900e-003	0.2236	1.8100e-003	0.2254	0.0593	1.6600e-003	0.0610		227.7540	227.7540	6.7100e-003		227.9217
Total	0.0857	0.0589	0.8056	2.2900e-003	0.2236	1.8100e-003	0.2254	0.0593	1.6600e-003	0.0610		227.7540	227.7540	6.7100e-003		227.9217

3.4 Grading - 2022

Unmitigated Construction On-Site

	ROG	NOx	CO	SO2	Fugitive PM10	Exhaust PM10	PM10 Total	Fugitive PM2.5	Exhaust PM2.5	PM2.5 Total	Bio- CO2	NBio- CO2	Total CO2	CH4	N2O	CO2e
Category	lb/day										lb/day					
Fugitive Dust					8.6733	0.0000	8.6733	3.5965	0.0000	3.5965			0.0000			0.0000
Off-Road	3.6248	38.8435	29.0415	0.0621		1.6349	1.6349		1.5041	1.5041		6,011.4105	6,011.4105	1.9442		6,060.0158
Total	3.6248	38.8435	29.0415	0.0621	8.6733	1.6349	10.3082	3.5965	1.5041	5.1006		6,011.4105	6,011.4105	1.9442		6,060.0158

Village South Specific Plan (Proposed) - Los Angeles-South Coast County, Summer

3.4 Grading - 2022

Unmitigated Construction Off-Site

	ROG	NOx	CO	SO2	Fugitive PM10	Exhaust PM10	PM10 Total	Fugitive PM2.5	Exhaust PM2.5	PM2.5 Total	Bio- CO2	NBio- CO2	Total CO2	CH4	N2O	CO2e
Category	lb/day										lb/day					
Hauling	0.0000	0.0000	0.0000	0.0000	0.0000	0.0000	0.0000	0.0000	0.0000	0.0000		0.0000	0.0000	0.0000		0.0000
Vendor	0.0000	0.0000	0.0000	0.0000	0.0000	0.0000	0.0000	0.0000	0.0000	0.0000		0.0000	0.0000	0.0000		0.0000
Worker	0.0803	0.0532	0.7432	2.2100e-003	0.2236	1.7500e-003	0.2253	0.0593	1.6100e-003	0.0609		219.7425	219.7425	6.0600e-003		219.8941
Total	0.0803	0.0532	0.7432	2.2100e-003	0.2236	1.7500e-003	0.2253	0.0593	1.6100e-003	0.0609		219.7425	219.7425	6.0600e-003		219.8941

Mitigated Construction On-Site

	ROG	NOx	CO	SO2	Fugitive PM10	Exhaust PM10	PM10 Total	Fugitive PM2.5	Exhaust PM2.5	PM2.5 Total	Bio- CO2	NBio- CO2	Total CO2	CH4	N2O	CO2e
Category	lb/day										lb/day					
Fugitive Dust					8.6733	0.0000	8.6733	3.5965	0.0000	3.5965			0.0000			0.0000
Off-Road	3.6248	38.8435	29.0415	0.0621		1.6349	1.6349		1.5041	1.5041	0.0000	6,011.4105	6,011.4105	1.9442		6,060.0158
Total	3.6248	38.8435	29.0415	0.0621	8.6733	1.6349	10.3082	3.5965	1.5041	5.1006	0.0000	6,011.4105	6,011.4105	1.9442		6,060.0158

Village South Specific Plan (Proposed) - Los Angeles-South Coast County, Summer

3.4 Grading - 2022

Mitigated Construction Off-Site

	ROG	NOx	CO	SO2	Fugitive PM10	Exhaust PM10	PM10 Total	Fugitive PM2.5	Exhaust PM2.5	PM2.5 Total	Bio- CO2	NBio- CO2	Total CO2	CH4	N2O	CO2e
Category	lb/day										lb/day					
Hauling	0.0000	0.0000	0.0000	0.0000	0.0000	0.0000	0.0000	0.0000	0.0000	0.0000		0.0000	0.0000	0.0000		0.0000
Vendor	0.0000	0.0000	0.0000	0.0000	0.0000	0.0000	0.0000	0.0000	0.0000	0.0000		0.0000	0.0000	0.0000		0.0000
Worker	0.0803	0.0532	0.7432	2.2100e-003	0.2236	1.7500e-003	0.2253	0.0593	1.6100e-003	0.0609		219.7425	219.7425	6.0600e-003		219.8941
Total	0.0803	0.0532	0.7432	2.2100e-003	0.2236	1.7500e-003	0.2253	0.0593	1.6100e-003	0.0609		219.7425	219.7425	6.0600e-003		219.8941

3.5 Building Construction - 2022

Unmitigated Construction On-Site

	ROG	NOx	CO	SO2	Fugitive PM10	Exhaust PM10	PM10 Total	Fugitive PM2.5	Exhaust PM2.5	PM2.5 Total	Bio- CO2	NBio- CO2	Total CO2	CH4	N2O	CO2e
Category	lb/day										lb/day					
Off-Road	1.7062	15.6156	16.3634	0.0269		0.8090	0.8090		0.7612	0.7612		2,554.3336	2,554.3336	0.6120		2,569.6322
Total	1.7062	15.6156	16.3634	0.0269		0.8090	0.8090		0.7612	0.7612		2,554.3336	2,554.3336	0.6120		2,569.6322

Village South Specific Plan (Proposed) - Los Angeles-South Coast County, Summer

3.5 Building Construction - 2022

Unmitigated Construction Off-Site

	ROG	NOx	CO	SO2	Fugitive PM10	Exhaust PM10	PM10 Total	Fugitive PM2.5	Exhaust PM2.5	PM2.5 Total	Bio- CO2	NBio- CO2	Total CO2	CH4	N2O	CO2e
Category	lb/day										lb/day					
Hauling	0.0000	0.0000	0.0000	0.0000	0.0000	0.0000	0.0000	0.0000	0.0000	0.0000		0.0000	0.0000	0.0000		0.0000
Vendor	0.4079	13.2032	3.4341	0.0364	0.9155	0.0248	0.9404	0.2636	0.0237	0.2873		3,896.548 2	3,896.548 2	0.2236		3,902.138 4
Worker	3.2162	2.1318	29.7654	0.0883	8.9533	0.0701	9.0234	2.3745	0.0646	2.4390		8,800.685 7	8,800.685 7	0.2429		8,806.758 2
Total	3.6242	15.3350	33.1995	0.1247	9.8688	0.0949	9.9637	2.6381	0.0883	2.7263		12,697.23 39	12,697.23 39	0.4665		12,708.89 66

Mitigated Construction On-Site

	ROG	NOx	CO	SO2	Fugitive PM10	Exhaust PM10	PM10 Total	Fugitive PM2.5	Exhaust PM2.5	PM2.5 Total	Bio- CO2	NBio- CO2	Total CO2	CH4	N2O	CO2e
Category	lb/day										lb/day					
Off-Road	1.7062	15.6156	16.3634	0.0269		0.8090	0.8090		0.7612	0.7612	0.0000	2,554.333 6	2,554.333 6	0.6120		2,569.632 2
Total	1.7062	15.6156	16.3634	0.0269		0.8090	0.8090		0.7612	0.7612	0.0000	2,554.333 6	2,554.333 6	0.6120		2,569.632 2

Village South Specific Plan (Proposed) - Los Angeles-South Coast County, Summer

3.5 Building Construction - 2022

Mitigated Construction Off-Site

	ROG	NOx	CO	SO2	Fugitive PM10	Exhaust PM10	PM10 Total	Fugitive PM2.5	Exhaust PM2.5	PM2.5 Total	Bio- CO2	NBio- CO2	Total CO2	CH4	N2O	CO2e
Category	lb/day										lb/day					
Hauling	0.0000	0.0000	0.0000	0.0000	0.0000	0.0000	0.0000	0.0000	0.0000	0.0000		0.0000	0.0000	0.0000		0.0000
Vendor	0.4079	13.2032	3.4341	0.0364	0.9155	0.0248	0.9404	0.2636	0.0237	0.2873		3,896.548 2	3,896.548 2	0.2236		3,902.138 4
Worker	3.2162	2.1318	29.7654	0.0883	8.9533	0.0701	9.0234	2.3745	0.0646	2.4390		8,800.685 7	8,800.685 7	0.2429		8,806.758 2
Total	3.6242	15.3350	33.1995	0.1247	9.8688	0.0949	9.9637	2.6381	0.0883	2.7263		12,697.23 39	12,697.23 39	0.4665		12,708.89 66

3.5 Building Construction - 2023

Unmitigated Construction On-Site

	ROG	NOx	CO	SO2	Fugitive PM10	Exhaust PM10	PM10 Total	Fugitive PM2.5	Exhaust PM2.5	PM2.5 Total	Bio- CO2	NBio- CO2	Total CO2	CH4	N2O	CO2e
Category	lb/day										lb/day					
Off-Road	1.5728	14.3849	16.2440	0.0269		0.6997	0.6997		0.6584	0.6584		2,555.209 9	2,555.209 9	0.6079		2,570.406 1
Total	1.5728	14.3849	16.2440	0.0269		0.6997	0.6997		0.6584	0.6584		2,555.209 9	2,555.209 9	0.6079		2,570.406 1

Village South Specific Plan (Proposed) - Los Angeles-South Coast County, Summer

3.5 Building Construction - 2023

Unmitigated Construction Off-Site

	ROG	NOx	CO	SO2	Fugitive PM10	Exhaust PM10	PM10 Total	Fugitive PM2.5	Exhaust PM2.5	PM2.5 Total	Bio- CO2	NBio- CO2	Total CO2	CH4	N2O	CO2e
Category	lb/day										lb/day					
Hauling	0.0000	0.0000	0.0000	0.0000	0.0000	0.0000	0.0000	0.0000	0.0000	0.0000		0.0000	0.0000	0.0000		0.0000
Vendor	0.3027	10.0181	3.1014	0.0352	0.9156	0.0116	0.9271	0.2636	0.0111	0.2747		3,773.876 2	3,773.876 2	0.1982		3,778.830 0
Worker	3.0203	1.9287	27.4113	0.0851	8.9533	0.0681	9.0214	2.3745	0.0627	2.4372		8,478.440 8	8,478.440 8	0.2190		8,483.916 0
Total	3.3229	11.9468	30.5127	0.1203	9.8688	0.0797	9.9485	2.6381	0.0738	2.7118		12,252.31 70	12,252.31 70	0.4172		12,262.74 60

Mitigated Construction On-Site

	ROG	NOx	CO	SO2	Fugitive PM10	Exhaust PM10	PM10 Total	Fugitive PM2.5	Exhaust PM2.5	PM2.5 Total	Bio- CO2	NBio- CO2	Total CO2	CH4	N2O	CO2e
Category	lb/day										lb/day					
Off-Road	1.5728	14.3849	16.2440	0.0269		0.6997	0.6997		0.6584	0.6584	0.0000	2,555.209 9	2,555.209 9	0.6079		2,570.406 1
Total	1.5728	14.3849	16.2440	0.0269		0.6997	0.6997		0.6584	0.6584	0.0000	2,555.209 9	2,555.209 9	0.6079		2,570.406 1

Village South Specific Plan (Proposed) - Los Angeles-South Coast County, Summer

3.5 Building Construction - 2023

Mitigated Construction Off-Site

	ROG	NOx	CO	SO2	Fugitive PM10	Exhaust PM10	PM10 Total	Fugitive PM2.5	Exhaust PM2.5	PM2.5 Total	Bio- CO2	NBio- CO2	Total CO2	CH4	N2O	CO2e
Category	lb/day										lb/day					
Hauling	0.0000	0.0000	0.0000	0.0000	0.0000	0.0000	0.0000	0.0000	0.0000	0.0000		0.0000	0.0000	0.0000		0.0000
Vendor	0.3027	10.0181	3.1014	0.0352	0.9156	0.0116	0.9271	0.2636	0.0111	0.2747		3,773.876 2	3,773.876 2	0.1982		3,778.830 0
Worker	3.0203	1.9287	27.4113	0.0851	8.9533	0.0681	9.0214	2.3745	0.0627	2.4372		8,478.440 8	8,478.440 8	0.2190		8,483.916 0
Total	3.3229	11.9468	30.5127	0.1203	9.8688	0.0797	9.9485	2.6381	0.0738	2.7118		12,252.31 70	12,252.31 70	0.4172		12,262.74 60

3.6 Paving - 2023

Unmitigated Construction On-Site

	ROG	NOx	CO	SO2	Fugitive PM10	Exhaust PM10	PM10 Total	Fugitive PM2.5	Exhaust PM2.5	PM2.5 Total	Bio- CO2	NBio- CO2	Total CO2	CH4	N2O	CO2e
Category	lb/day										lb/day					
Off-Road	1.0327	10.1917	14.5842	0.0228		0.5102	0.5102		0.4694	0.4694		2,207.584 1	2,207.584 1	0.7140		2,225.433 6
Paving	0.0000					0.0000	0.0000		0.0000	0.0000			0.0000			0.0000
Total	1.0327	10.1917	14.5842	0.0228		0.5102	0.5102		0.4694	0.4694		2,207.584 1	2,207.584 1	0.7140		2,225.433 6

Village South Specific Plan (Proposed) - Los Angeles-South Coast County, Summer

3.6 Paving - 2023

Unmitigated Construction Off-Site

	ROG	NOx	CO	SO2	Fugitive PM10	Exhaust PM10	PM10 Total	Fugitive PM2.5	Exhaust PM2.5	PM2.5 Total	Bio- CO2	NBio- CO2	Total CO2	CH4	N2O	CO2e
Category	lb/day										lb/day					
Hauling	0.0000	0.0000	0.0000	0.0000	0.0000	0.0000	0.0000	0.0000	0.0000	0.0000		0.0000	0.0000	0.0000		0.0000
Vendor	0.0000	0.0000	0.0000	0.0000	0.0000	0.0000	0.0000	0.0000	0.0000	0.0000		0.0000	0.0000	0.0000		0.0000
Worker	0.0566	0.0361	0.5133	1.5900e-003	0.1677	1.2800e-003	0.1689	0.0445	1.1700e-003	0.0456		158.7723	158.7723	4.1000e-003		158.8748
Total	0.0566	0.0361	0.5133	1.5900e-003	0.1677	1.2800e-003	0.1689	0.0445	1.1700e-003	0.0456		158.7723	158.7723	4.1000e-003		158.8748

Mitigated Construction On-Site

	ROG	NOx	CO	SO2	Fugitive PM10	Exhaust PM10	PM10 Total	Fugitive PM2.5	Exhaust PM2.5	PM2.5 Total	Bio- CO2	NBio- CO2	Total CO2	CH4	N2O	CO2e
Category	lb/day										lb/day					
Off-Road	1.0327	10.1917	14.5842	0.0228		0.5102	0.5102		0.4694	0.4694	0.0000	2,207.5841	2,207.5841	0.7140		2,225.4336
Paving	0.0000					0.0000	0.0000		0.0000	0.0000			0.0000			0.0000
Total	1.0327	10.1917	14.5842	0.0228		0.5102	0.5102		0.4694	0.4694	0.0000	2,207.5841	2,207.5841	0.7140		2,225.4336

Village South Specific Plan (Proposed) - Los Angeles-South Coast County, Summer

3.6 Paving - 2023

Mitigated Construction Off-Site

	ROG	NOx	CO	SO2	Fugitive PM10	Exhaust PM10	PM10 Total	Fugitive PM2.5	Exhaust PM2.5	PM2.5 Total	Bio- CO2	NBio- CO2	Total CO2	CH4	N2O	CO2e
Category	lb/day										lb/day					
Hauling	0.0000	0.0000	0.0000	0.0000	0.0000	0.0000	0.0000	0.0000	0.0000	0.0000		0.0000	0.0000	0.0000		0.0000
Vendor	0.0000	0.0000	0.0000	0.0000	0.0000	0.0000	0.0000	0.0000	0.0000	0.0000		0.0000	0.0000	0.0000		0.0000
Worker	0.0566	0.0361	0.5133	1.5900e-003	0.1677	1.2800e-003	0.1689	0.0445	1.1700e-003	0.0456		158.7723	158.7723	4.1000e-003		158.8748
Total	0.0566	0.0361	0.5133	1.5900e-003	0.1677	1.2800e-003	0.1689	0.0445	1.1700e-003	0.0456		158.7723	158.7723	4.1000e-003		158.8748

3.6 Paving - 2024

Unmitigated Construction On-Site

	ROG	NOx	CO	SO2	Fugitive PM10	Exhaust PM10	PM10 Total	Fugitive PM2.5	Exhaust PM2.5	PM2.5 Total	Bio- CO2	NBio- CO2	Total CO2	CH4	N2O	CO2e
Category	lb/day										lb/day					
Off-Road	0.9882	9.5246	14.6258	0.0228		0.4685	0.4685		0.4310	0.4310		2,207.5472	2,207.5472	0.7140		2,225.3963
Paving	0.0000					0.0000	0.0000		0.0000	0.0000			0.0000			0.0000
Total	0.9882	9.5246	14.6258	0.0228		0.4685	0.4685		0.4310	0.4310		2,207.5472	2,207.5472	0.7140		2,225.3963

Village South Specific Plan (Proposed) - Los Angeles-South Coast County, Summer

3.6 Paving - 2024

Unmitigated Construction Off-Site

	ROG	NOx	CO	SO2	Fugitive PM10	Exhaust PM10	PM10 Total	Fugitive PM2.5	Exhaust PM2.5	PM2.5 Total	Bio- CO2	NBio- CO2	Total CO2	CH4	N2O	CO2e
Category	lb/day										lb/day					
Hauling	0.0000	0.0000	0.0000	0.0000	0.0000	0.0000	0.0000	0.0000	0.0000	0.0000		0.0000	0.0000	0.0000		0.0000
Vendor	0.0000	0.0000	0.0000	0.0000	0.0000	0.0000	0.0000	0.0000	0.0000	0.0000		0.0000	0.0000	0.0000		0.0000
Worker	0.0535	0.0329	0.4785	1.5400e-003	0.1677	1.2600e-003	0.1689	0.0445	1.1600e-003	0.0456		153.8517	153.8517	3.7600e-003		153.9458
Total	0.0535	0.0329	0.4785	1.5400e-003	0.1677	1.2600e-003	0.1689	0.0445	1.1600e-003	0.0456		153.8517	153.8517	3.7600e-003		153.9458

Mitigated Construction On-Site

	ROG	NOx	CO	SO2	Fugitive PM10	Exhaust PM10	PM10 Total	Fugitive PM2.5	Exhaust PM2.5	PM2.5 Total	Bio- CO2	NBio- CO2	Total CO2	CH4	N2O	CO2e
Category	lb/day										lb/day					
Off-Road	0.9882	9.5246	14.6258	0.0228		0.4685	0.4685		0.4310	0.4310	0.0000	2,207.5472	2,207.5472	0.7140		2,225.3963
Paving	0.0000					0.0000	0.0000		0.0000	0.0000			0.0000			0.0000
Total	0.9882	9.5246	14.6258	0.0228		0.4685	0.4685		0.4310	0.4310	0.0000	2,207.5472	2,207.5472	0.7140		2,225.3963

Village South Specific Plan (Proposed) - Los Angeles-South Coast County, Summer

3.6 Paving - 2024

Mitigated Construction Off-Site

	ROG	NOx	CO	SO2	Fugitive PM10	Exhaust PM10	PM10 Total	Fugitive PM2.5	Exhaust PM2.5	PM2.5 Total	Bio- CO2	NBio- CO2	Total CO2	CH4	N2O	CO2e
Category	lb/day										lb/day					
Hauling	0.0000	0.0000	0.0000	0.0000	0.0000	0.0000	0.0000	0.0000	0.0000	0.0000		0.0000	0.0000	0.0000		0.0000
Vendor	0.0000	0.0000	0.0000	0.0000	0.0000	0.0000	0.0000	0.0000	0.0000	0.0000		0.0000	0.0000	0.0000		0.0000
Worker	0.0535	0.0329	0.4785	1.5400e-003	0.1677	1.2600e-003	0.1689	0.0445	1.1600e-003	0.0456		153.8517	153.8517	3.7600e-003		153.9458
Total	0.0535	0.0329	0.4785	1.5400e-003	0.1677	1.2600e-003	0.1689	0.0445	1.1600e-003	0.0456		153.8517	153.8517	3.7600e-003		153.9458

3.7 Architectural Coating - 2024

Unmitigated Construction On-Site

	ROG	NOx	CO	SO2	Fugitive PM10	Exhaust PM10	PM10 Total	Fugitive PM2.5	Exhaust PM2.5	PM2.5 Total	Bio- CO2	NBio- CO2	Total CO2	CH4	N2O	CO2e
Category	lb/day										lb/day					
Archit. Coating	236.4115					0.0000	0.0000		0.0000	0.0000			0.0000			0.0000
Off-Road	0.1808	1.2188	1.8101	2.9700e-003		0.0609	0.0609		0.0609	0.0609		281.4481	281.4481	0.0159		281.8443
Total	236.5923	1.2188	1.8101	2.9700e-003		0.0609	0.0609		0.0609	0.0609		281.4481	281.4481	0.0159		281.8443

Village South Specific Plan (Proposed) - Los Angeles-South Coast County, Summer

3.7 Architectural Coating - 2024

Unmitigated Construction Off-Site

	ROG	NOx	CO	SO2	Fugitive PM10	Exhaust PM10	PM10 Total	Fugitive PM2.5	Exhaust PM2.5	PM2.5 Total	Bio- CO2	NBio- CO2	Total CO2	CH4	N2O	CO2e
Category	lb/day										lb/day					
Hauling	0.0000	0.0000	0.0000	0.0000	0.0000	0.0000	0.0000	0.0000	0.0000	0.0000		0.0000	0.0000	0.0000		0.0000
Vendor	0.0000	0.0000	0.0000	0.0000	0.0000	0.0000	0.0000	0.0000	0.0000	0.0000		0.0000	0.0000	0.0000		0.0000
Worker	0.5707	0.3513	5.1044	0.0165	1.7884	0.0134	1.8018	0.4743	0.0123	0.4866		1,641.085 2	1,641.085 2	0.0401		1,642.088 6
Total	0.5707	0.3513	5.1044	0.0165	1.7884	0.0134	1.8018	0.4743	0.0123	0.4866		1,641.085 2	1,641.085 2	0.0401		1,642.088 6

Mitigated Construction On-Site

	ROG	NOx	CO	SO2	Fugitive PM10	Exhaust PM10	PM10 Total	Fugitive PM2.5	Exhaust PM2.5	PM2.5 Total	Bio- CO2	NBio- CO2	Total CO2	CH4	N2O	CO2e
Category	lb/day										lb/day					
Archit. Coating	236.4115					0.0000	0.0000		0.0000	0.0000			0.0000			0.0000
Off-Road	0.1808	1.2188	1.8101	2.9700e-003		0.0609	0.0609		0.0609	0.0609	0.0000	281.4481	281.4481	0.0159		281.8443
Total	236.5923	1.2188	1.8101	2.9700e-003		0.0609	0.0609		0.0609	0.0609	0.0000	281.4481	281.4481	0.0159		281.8443

Village South Specific Plan (Proposed) - Los Angeles-South Coast County, Summer

3.7 Architectural Coating - 2024

Mitigated Construction Off-Site

	ROG	NOx	CO	SO2	Fugitive PM10	Exhaust PM10	PM10 Total	Fugitive PM2.5	Exhaust PM2.5	PM2.5 Total	Bio- CO2	NBio- CO2	Total CO2	CH4	N2O	CO2e
Category	lb/day										lb/day					
Hauling	0.0000	0.0000	0.0000	0.0000	0.0000	0.0000	0.0000	0.0000	0.0000	0.0000		0.0000	0.0000	0.0000		0.0000
Vendor	0.0000	0.0000	0.0000	0.0000	0.0000	0.0000	0.0000	0.0000	0.0000	0.0000		0.0000	0.0000	0.0000		0.0000
Worker	0.5707	0.3513	5.1044	0.0165	1.7884	0.0134	1.8018	0.4743	0.0123	0.4866		1,641.085 2	1,641.085 2	0.0401		1,642.088 6
Total	0.5707	0.3513	5.1044	0.0165	1.7884	0.0134	1.8018	0.4743	0.0123	0.4866		1,641.085 2	1,641.085 2	0.0401		1,642.088 6

4.0 Operational Detail - Mobile

4.1 Mitigation Measures Mobile

Village South Specific Plan (Proposed) - Los Angeles-South Coast County, Summer

	ROG	NOx	CO	SO2	Fugitive PM10	Exhaust PM10	PM10 Total	Fugitive PM2.5	Exhaust PM2.5	PM2.5 Total	Bio- CO2	NBio- CO2	Total CO2	CH4	N2O	CO2e
Category	lb/day										lb/day					
Mitigated	9.8489	45.4304	114.8495	0.4917	45.9592	0.3360	46.2951	12.2950	0.3119	12.6070		50,306.60 34	50,306.60 34	2.1807		50,361.12 08
Unmitigated	9.8489	45.4304	114.8495	0.4917	45.9592	0.3360	46.2951	12.2950	0.3119	12.6070		50,306.60 34	50,306.60 34	2.1807		50,361.12 08

4.2 Trip Summary Information

Land Use	Average Daily Trip Rate			Unmitigated	Mitigated
	Weekday	Saturday	Sunday	Annual VMT	Annual VMT
Apartments Low Rise	145.75	154.25	154.00	506,227	506,227
Apartments Mid Rise	4,026.75	3,773.25	4075.50	13,660,065	13,660,065
General Office Building	288.45	62.55	31.05	706,812	706,812
High Turnover (Sit Down Restaurant)	2,368.80	2,873.52	2817.72	3,413,937	3,413,937
Hotel	192.00	187.50	160.00	445,703	445,703
Quality Restaurant	501.12	511.92	461.20	707,488	707,488
Regional Shopping Center	528.08	601.44	357.84	1,112,221	1,112,221
Total	8,050.95	8,164.43	8,057.31	20,552,452	20,552,452

4.3 Trip Type Information

Village South Specific Plan (Proposed) - Los Angeles-South Coast County, Summer

Land Use	Miles			Trip %			Trip Purpose %		
	H-W or C-W	H-S or C-C	H-O or C-NW	H-W or C-W	H-S or C-C	H-O or C-NW	Primary	Diverted	Pass-by
Apartments Low Rise	14.70	5.90	8.70	40.20	19.20	40.60	86	11	3
Apartments Mid Rise	14.70	5.90	8.70	40.20	19.20	40.60	86	11	3
General Office Building	16.60	8.40	6.90	33.00	48.00	19.00	77	19	4
High Turnover (Sit Down Restaurant)	16.60	8.40	6.90	8.50	72.50	19.00	37	20	43
Hotel	16.60	8.40	6.90	19.40	61.60	19.00	58	38	4
Quality Restaurant	16.60	8.40	6.90	12.00	69.00	19.00	38	18	44
Regional Shopping Center	16.60	8.40	6.90	16.30	64.70	19.00	54	35	11

4.4 Fleet Mix

Land Use	LDA	LDT1	LDT2	MDV	LHD1	LHD2	MHD	HHD	OBUS	UBUS	MCY	SBUS	MH
Apartments Low Rise	0.543088	0.044216	0.209971	0.116369	0.014033	0.006332	0.021166	0.033577	0.002613	0.001817	0.005285	0.000712	0.000821
Apartments Mid Rise	0.543088	0.044216	0.209971	0.116369	0.014033	0.006332	0.021166	0.033577	0.002613	0.001817	0.005285	0.000712	0.000821
General Office Building	0.543088	0.044216	0.209971	0.116369	0.014033	0.006332	0.021166	0.033577	0.002613	0.001817	0.005285	0.000712	0.000821
High Turnover (Sit Down Restaurant)	0.543088	0.044216	0.209971	0.116369	0.014033	0.006332	0.021166	0.033577	0.002613	0.001817	0.005285	0.000712	0.000821
Hotel	0.543088	0.044216	0.209971	0.116369	0.014033	0.006332	0.021166	0.033577	0.002613	0.001817	0.005285	0.000712	0.000821
Quality Restaurant	0.543088	0.044216	0.209971	0.116369	0.014033	0.006332	0.021166	0.033577	0.002613	0.001817	0.005285	0.000712	0.000821
Regional Shopping Center	0.543088	0.044216	0.209971	0.116369	0.014033	0.006332	0.021166	0.033577	0.002613	0.001817	0.005285	0.000712	0.000821

5.0 Energy Detail

Historical Energy Use: N

5.1 Mitigation Measures Energy

Village South Specific Plan (Proposed) - Los Angeles-South Coast County, Summer

	ROG	NOx	CO	SO2	Fugitive PM10	Exhaust PM10	PM10 Total	Fugitive PM2.5	Exhaust PM2.5	PM2.5 Total	Bio- CO2	NBio- CO2	Total CO2	CH4	N2O	CO2e
Category	lb/day										lb/day					
NaturalGas Mitigated	0.7660	6.7462	4.2573	0.0418		0.5292	0.5292		0.5292	0.5292		8,355.983 2	8,355.983 2	0.1602	0.1532	8,405.638 7
NaturalGas Unmitigated	0.7660	6.7462	4.2573	0.0418		0.5292	0.5292		0.5292	0.5292		8,355.983 2	8,355.983 2	0.1602	0.1532	8,405.638 7

Village South Specific Plan (Proposed) - Los Angeles-South Coast County, Summer

5.2 Energy by Land Use - NaturalGas

Unmitigated

	NaturalGas Use	ROG	NOx	CO	SO2	Fugitive PM10	Exhaust PM10	PM10 Total	Fugitive PM2.5	Exhaust PM2.5	PM2.5 Total	Bio- CO2	NBio- CO2	Total CO2	CH4	N2O	CO2e
Land Use	kBTU/yr	lb/day										lb/day					
Apartments Low Rise	1119.16	0.0121	0.1031	0.0439	6.6000e-004		8.3400e-003	8.3400e-003		8.3400e-003	8.3400e-003		131.6662	131.6662	2.5200e-003	2.4100e-003	132.4486
Apartments Mid Rise	35784.3	0.3859	3.2978	1.4033	0.0211		0.2666	0.2666		0.2666	0.2666		4,209.9164	4,209.9164	0.0807	0.0772	4,234.9339
General Office Building	1283.42	0.0138	0.1258	0.1057	7.5000e-004		9.5600e-003	9.5600e-003		9.5600e-003	9.5600e-003		150.9911	150.9911	2.8900e-003	2.7700e-003	151.8884
High Turnover (Sit Down Restaurant)	22759.9	0.2455	2.2314	1.8743	0.0134		0.1696	0.1696		0.1696	0.1696		2,677.6342	2,677.6342	0.0513	0.0491	2,693.5460
Hotel	4769.72	0.0514	0.4676	0.3928	2.8100e-003		0.0355	0.0355		0.0355	0.0355		561.1436	561.1436	0.0108	0.0103	564.4782
Quality Restaurant	5057.75	0.0545	0.4959	0.4165	2.9800e-003		0.0377	0.0377		0.0377	0.0377		595.0298	595.0298	0.0114	0.0109	598.5658
Regional Shopping Center	251.616	2.7100e-003	0.0247	0.0207	1.5000e-004		1.8700e-003	1.8700e-003		1.8700e-003	1.8700e-003		29.6019	29.6019	5.7000e-004	5.4000e-004	29.7778
Total		0.7660	6.7463	4.2573	0.0418		0.5292	0.5292		0.5292	0.5292		8,355.9832	8,355.9832	0.1602	0.1532	8,405.6387

Village South Specific Plan (Proposed) - Los Angeles-South Coast County, Summer

5.2 Energy by Land Use - NaturalGas

Mitigated

	NaturalGas Use	ROG	NOx	CO	SO2	Fugitive PM10	Exhaust PM10	PM10 Total	Fugitive PM2.5	Exhaust PM2.5	PM2.5 Total	Bio- CO2	NBio- CO2	Total CO2	CH4	N2O	CO2e
Land Use	kBTU/yr	lb/day										lb/day					
Apartments Low Rise	1.11916	0.0121	0.1031	0.0439	6.6000e-004		8.3400e-003	8.3400e-003		8.3400e-003	8.3400e-003		131.6662	131.6662	2.5200e-003	2.4100e-003	132.4486
Apartments Mid Rise	35.7843	0.3859	3.2978	1.4033	0.0211		0.2666	0.2666		0.2666	0.2666		4,209.9164	4,209.9164	0.0807	0.0772	4,234.9339
General Office Building	1.28342	0.0138	0.1258	0.1057	7.5000e-004		9.5600e-003	9.5600e-003		9.5600e-003	9.5600e-003		150.9911	150.9911	2.8900e-003	2.7700e-003	151.8884
High Turnover (Sit Down Restaurant)	22.7599	0.2455	2.2314	1.8743	0.0134		0.1696	0.1696		0.1696	0.1696		2,677.6342	2,677.6342	0.0513	0.0491	2,693.5460
Hotel	4.76972	0.0514	0.4676	0.3928	2.8100e-003		0.0355	0.0355		0.0355	0.0355		561.1436	561.1436	0.0108	0.0103	564.4782
Quality Restaurant	5.05775	0.0545	0.4959	0.4165	2.9800e-003		0.0377	0.0377		0.0377	0.0377		595.0298	595.0298	0.0114	0.0109	598.5658
Regional Shopping Center	0.251616	2.7100e-003	0.0247	0.0207	1.5000e-004		1.8700e-003	1.8700e-003		1.8700e-003	1.8700e-003		29.6019	29.6019	5.7000e-004	5.4000e-004	29.7778
Total		0.7660	6.7463	4.2573	0.0418		0.5292	0.5292		0.5292	0.5292		8,355.9832	8,355.9832	0.1602	0.1532	8,405.6387

6.0 Area Detail

6.1 Mitigation Measures Area

Village South Specific Plan (Proposed) - Los Angeles-South Coast County, Summer

	ROG	NOx	CO	SO2	Fugitive PM10	Exhaust PM10	PM10 Total	Fugitive PM2.5	Exhaust PM2.5	PM2.5 Total	Bio- CO2	NBio- CO2	Total CO2	CH4	N2O	CO2e
Category	lb/day										lb/day					
Mitigated	30.5020	15.0496	88.4430	0.0944		1.5974	1.5974		1.5974	1.5974	0.0000	18,148.5950	18,148.5950	0.4874	0.3300	18,259.1192
Unmitigated	30.5020	15.0496	88.4430	0.0944		1.5974	1.5974		1.5974	1.5974	0.0000	18,148.5950	18,148.5950	0.4874	0.3300	18,259.1192

6.2 Area by SubCategory

Unmitigated

	ROG	NOx	CO	SO2	Fugitive PM10	Exhaust PM10	PM10 Total	Fugitive PM2.5	Exhaust PM2.5	PM2.5 Total	Bio- CO2	NBio- CO2	Total CO2	CH4	N2O	CO2e
SubCategory	lb/day										lb/day					
Architectural Coating	2.2670					0.0000	0.0000		0.0000	0.0000			0.0000			0.0000
Consumer Products	24.1085					0.0000	0.0000		0.0000	0.0000			0.0000			0.0000
Hearth	1.6500	14.1000	6.0000	0.0900		1.1400	1.1400		1.1400	1.1400	0.0000	18,000.0000	18,000.0000	0.3450	0.3300	18,106.9650
Landscaping	2.4766	0.9496	82.4430	4.3600e-003		0.4574	0.4574		0.4574	0.4574		148.5950	148.5950	0.1424		152.1542
Total	30.5020	15.0496	88.4430	0.0944		1.5974	1.5974		1.5974	1.5974	0.0000	18,148.5950	18,148.5950	0.4874	0.3300	18,259.1192

Village South Specific Plan (Proposed) - Los Angeles-South Coast County, Summer

6.2 Area by SubCategory

Mitigated

	ROG	NOx	CO	SO2	Fugitive PM10	Exhaust PM10	PM10 Total	Fugitive PM2.5	Exhaust PM2.5	PM2.5 Total	Bio- CO2	NBio- CO2	Total CO2	CH4	N2O	CO2e
SubCategory	lb/day										lb/day					
Architectural Coating	2.2670					0.0000	0.0000		0.0000	0.0000			0.0000			0.0000
Consumer Products	24.1085					0.0000	0.0000		0.0000	0.0000			0.0000			0.0000
Hearth	1.6500	14.1000	6.0000	0.0900		1.1400	1.1400		1.1400	1.1400	0.0000	18,000.0000	18,000.0000	0.3450	0.3300	18,106.9650
Landscaping	2.4766	0.9496	82.4430	4.3600e-003		0.4574	0.4574		0.4574	0.4574		148.5950	148.5950	0.1424		152.1542
Total	30.5020	15.0496	88.4430	0.0944		1.5974	1.5974		1.5974	1.5974	0.0000	18,148.5950	18,148.5950	0.4874	0.3300	18,259.1192

7.0 Water Detail

7.1 Mitigation Measures Water

8.0 Waste Detail

8.1 Mitigation Measures Waste

9.0 Operational Offroad

Equipment Type	Number	Hours/Day	Days/Year	Horse Power	Load Factor	Fuel Type
----------------	--------	-----------	-----------	-------------	-------------	-----------

10.0 Stationary Equipment

Village South Specific Plan (Proposed) - Los Angeles-South Coast County, Summer

Fire Pumps and Emergency Generators

Equipment Type	Number	Hours/Day	Hours/Year	Horse Power	Load Factor	Fuel Type
----------------	--------	-----------	------------	-------------	-------------	-----------

Boilers

Equipment Type	Number	Heat Input/Day	Heat Input/Year	Boiler Rating	Fuel Type
----------------	--------	----------------	-----------------	---------------	-----------

User Defined Equipment

Equipment Type	Number
----------------	--------

11.0 Vegetation

Village South Specific Plan (Proposed) - Los Angeles-South Coast County, Winter

Village South Specific Plan (Proposed)
Los Angeles-South Coast County, Winter

1.0 Project Characteristics

1.1 Land Usage

Land Uses	Size	Metric	Lot Acreage	Floor Surface Area	Population
General Office Building	45.00	1000sqft	1.03	45,000.00	0
High Turnover (Sit Down Restaurant)	36.00	1000sqft	0.83	36,000.00	0
Hotel	50.00	Room	1.67	72,600.00	0
Quality Restaurant	8.00	1000sqft	0.18	8,000.00	0
Apartments Low Rise	25.00	Dwelling Unit	1.56	25,000.00	72
Apartments Mid Rise	975.00	Dwelling Unit	25.66	975,000.00	2789
Regional Shopping Center	56.00	1000sqft	1.29	56,000.00	0

1.2 Other Project Characteristics

Urbanization	Urban	Wind Speed (m/s)	2.2	Precipitation Freq (Days)	33
Climate Zone	9			Operational Year	2028
Utility Company	Southern California Edison				
CO2 Intensity (lb/MW hr)	702.44	CH4 Intensity (lb/MW hr)	0.029	N2O Intensity (lb/MW hr)	0.006

1.3 User Entered Comments & Non-Default Data

Village South Specific Plan (Proposed) - Los Angeles-South Coast County, Winter

Project Characteristics - Consistent with the DEIR's model.

Land Use - See SWAPE comment regarding residential and retail land uses.

Construction Phase - See SWAPE comment regarding individual construction phase lengths.

Demolition - Consistent with the DEIR's model. See SWAPE comment regarding demolition.

Vehicle Trips - Saturday trips consistent with the DEIR's model. See SWAPE comment regarding weekday and Sunday trips.

Woodstoves - Woodstoves and wood-burning fireplaces consistent with the DEIR's model. See SWAPE comment regarding gas fireplaces.

Energy Use -

Construction Off-road Equipment Mitigation - See SWAPE comment on construction-related mitigation.

Area Mitigation - See SWAPE comment regarding operational mitigation measures.

Water Mitigation - See SWAPE comment regarding operational mitigation measures.

Table Name	Column Name	Default Value	New Value
tblFireplaces	FireplaceWoodMass	1,019.20	0.00
tblFireplaces	FireplaceWoodMass	1,019.20	0.00
tblFireplaces	NumberWood	1.25	0.00
tblFireplaces	NumberWood	48.75	0.00
tblVehicleTrips	ST_TR	7.16	6.17
tblVehicleTrips	ST_TR	6.39	3.87
tblVehicleTrips	ST_TR	2.46	1.39
tblVehicleTrips	ST_TR	158.37	79.82
tblVehicleTrips	ST_TR	8.19	3.75
tblVehicleTrips	ST_TR	94.36	63.99
tblVehicleTrips	ST_TR	49.97	10.74
tblVehicleTrips	SU_TR	6.07	6.16
tblVehicleTrips	SU_TR	5.86	4.18
tblVehicleTrips	SU_TR	1.05	0.69
tblVehicleTrips	SU_TR	131.84	78.27

Village South Specific Plan (Proposed) - Los Angeles-South Coast County, Winter

tblVehicleTrips	SU_TR	5.95	3.20
tblVehicleTrips	SU_TR	72.16	57.65
tblVehicleTrips	SU_TR	25.24	6.39
tblVehicleTrips	WD_TR	6.59	5.83
tblVehicleTrips	WD_TR	6.65	4.13
tblVehicleTrips	WD_TR	11.03	6.41
tblVehicleTrips	WD_TR	127.15	65.80
tblVehicleTrips	WD_TR	8.17	3.84
tblVehicleTrips	WD_TR	89.95	62.64
tblVehicleTrips	WD_TR	42.70	9.43
tblWoodstoves	NumberCatalytic	1.25	0.00
tblWoodstoves	NumberCatalytic	48.75	0.00
tblWoodstoves	NumberNoncatalytic	1.25	0.00
tblWoodstoves	NumberNoncatalytic	48.75	0.00
tblWoodstoves	WoodstoveDayYear	25.00	0.00
tblWoodstoves	WoodstoveDayYear	25.00	0.00
tblWoodstoves	WoodstoveWoodMass	999.60	0.00
tblWoodstoves	WoodstoveWoodMass	999.60	0.00

2.0 Emissions Summary

Village South Specific Plan (Proposed) - Los Angeles-South Coast County, Winter

2.1 Overall Construction (Maximum Daily Emission)

Unmitigated Construction

	ROG	NOx	CO	SO2	Fugitive PM10	Exhaust PM10	PM10 Total	Fugitive PM2.5	Exhaust PM2.5	PM2.5 Total	Bio- CO2	NBio- CO2	Total CO2	CH4	N2O	CO2e
Year	lb/day										lb/day					
2021	4.2865	46.4651	31.6150	0.0642	18.2675	2.0461	20.3135	9.9840	1.8824	11.8664	0.0000	6,221.4937	6,221.4937	1.9491	0.0000	6,270.2214
2022	5.7218	38.9024	47.3319	0.1455	9.8688	1.6366	10.7736	3.6558	1.5057	5.1615	0.0000	14,630.3099	14,630.3099	1.9499	0.0000	14,657.2663
2023	5.2705	26.4914	44.5936	0.1413	9.8688	0.7800	10.6488	2.6381	0.7328	3.3708	0.0000	14,210.3424	14,210.3424	1.0230	0.0000	14,235.9160
2024	237.2328	9.5610	15.0611	0.0243	1.7884	0.4698	1.8628	0.4743	0.4322	0.5476	0.0000	2,352.4178	2,352.4178	0.7175	0.0000	2,370.3550
Maximum	237.2328	46.4651	47.3319	0.1455	18.2675	2.0461	20.3135	9.9840	1.8824	11.8664	0.0000	14,630.3099	14,630.3099	1.9499	0.0000	14,657.2663

Village South Specific Plan (Proposed) - Los Angeles-South Coast County, Winter

2.2 Overall Operational

Unmitigated Operational

	ROG	NOx	CO	SO2	Fugitive PM10	Exhaust PM10	PM10 Total	Fugitive PM2.5	Exhaust PM2.5	PM2.5 Total	Bio- CO2	NBio- CO2	Total CO2	CH4	N2O	CO2e
Category	lb/day										lb/day					
Area	30.5020	15.0496	88.4430	0.0944		1.5974	1.5974		1.5974	1.5974	0.0000	18,148.5950	18,148.5950	0.4874	0.3300	18,259.1192
Energy	0.7660	6.7462	4.2573	0.0418		0.5292	0.5292		0.5292	0.5292		8,355.9832	8,355.9832	0.1602	0.1532	8,405.6387
Mobile	9.5233	45.9914	110.0422	0.4681	45.9592	0.3373	46.2965	12.2950	0.3132	12.6083		47,917.8005	47,917.8005	2.1953		47,972.6839
Total	40.7912	67.7872	202.7424	0.6043	45.9592	2.4640	48.4231	12.2950	2.4399	14.7349	0.0000	74,422.3787	74,422.3787	2.8429	0.4832	74,637.4417

Mitigated Operational

	ROG	NOx	CO	SO2	Fugitive PM10	Exhaust PM10	PM10 Total	Fugitive PM2.5	Exhaust PM2.5	PM2.5 Total	Bio- CO2	NBio- CO2	Total CO2	CH4	N2O	CO2e
Category	lb/day										lb/day					
Area	30.5020	15.0496	88.4430	0.0944		1.5974	1.5974		1.5974	1.5974	0.0000	18,148.5950	18,148.5950	0.4874	0.3300	18,259.1192
Energy	0.7660	6.7462	4.2573	0.0418		0.5292	0.5292		0.5292	0.5292		8,355.9832	8,355.9832	0.1602	0.1532	8,405.6387
Mobile	9.5233	45.9914	110.0422	0.4681	45.9592	0.3373	46.2965	12.2950	0.3132	12.6083		47,917.8005	47,917.8005	2.1953		47,972.6839
Total	40.7912	67.7872	202.7424	0.6043	45.9592	2.4640	48.4231	12.2950	2.4399	14.7349	0.0000	74,422.3787	74,422.3787	2.8429	0.4832	74,637.4417

Village South Specific Plan (Proposed) - Los Angeles-South Coast County, Winter

	ROG	NOx	CO	SO2	Fugitive PM10	Exhaust PM10	PM10 Total	Fugitive PM2.5	Exhaust PM2.5	PM2.5 Total	Bio- CO2	NBio-CO2	Total CO2	CH4	N2O	CO2e
Percent Reduction	0.00	0.00	0.00	0.00	0.00	0.00	0.00	0.00	0.00	0.00	0.00	0.00	0.00	0.00	0.00	0.00

3.0 Construction Detail

Construction Phase

Phase Number	Phase Name	Phase Type	Start Date	End Date	Num Days Week	Num Days	Phase Description
1	Demolition	Demolition	9/1/2021	10/12/2021	5	30	
2	Site Preparation	Site Preparation	10/13/2021	11/9/2021	5	20	
3	Grading	Grading	11/10/2021	1/11/2022	5	45	
4	Building Construction	Building Construction	1/12/2022	12/12/2023	5	500	
5	Paving	Paving	12/13/2023	1/30/2024	5	35	
6	Architectural Coating	Architectural Coating	1/31/2024	3/19/2024	5	35	

Acres of Grading (Site Preparation Phase): 0

Acres of Grading (Grading Phase): 112.5

Acres of Paving: 0

Residential Indoor: 2,025,000; Residential Outdoor: 675,000; Non-Residential Indoor: 326,400; Non-Residential Outdoor: 108,800; Striped Parking Area: 0 (Architectural Coating – sqft)

OffRoad Equipment

Village South Specific Plan (Proposed) - Los Angeles-South Coast County, Winter

Phase Name	Offroad Equipment Type	Amount	Usage Hours	Horse Power	Load Factor
Demolition	Concrete/Industrial Saws	1	8.00	81	0.73
Demolition	Excavators	3	8.00	158	0.38
Demolition	Rubber Tired Dozers	2	8.00	247	0.40
Site Preparation	Rubber Tired Dozers	3	8.00	247	0.40
Site Preparation	Tractors/Loaders/Backhoes	4	8.00	97	0.37
Grading	Excavators	2	8.00	158	0.38
Grading	Graders	1	8.00	187	0.41
Grading	Rubber Tired Dozers	1	8.00	247	0.40
Grading	Scrapers	2	8.00	367	0.48
Grading	Tractors/Loaders/Backhoes	2	8.00	97	0.37
Building Construction	Cranes	1	7.00	231	0.29
Building Construction	Forklifts	3	8.00	89	0.20
Building Construction	Generator Sets	1	8.00	84	0.74
Building Construction	Tractors/Loaders/Backhoes	3	7.00	97	0.37
Building Construction	Welders	1	8.00	46	0.45
Paving	Pavers	2	8.00	130	0.42
Paving	Paving Equipment	2	8.00	132	0.36
Paving	Rollers	2	8.00	80	0.38
Architectural Coating	Air Compressors	1	6.00	78	0.48

Trips and VMT

Village South Specific Plan (Proposed) - Los Angeles-South Coast County, Winter

Phase Name	Offroad Equipment Count	Worker Trip Number	Vendor Trip Number	Hauling Trip Number	Worker Trip Length	Vendor Trip Length	Hauling Trip Length	Worker Vehicle Class	Vendor Vehicle Class	Hauling Vehicle Class
Demolition	6	15.00	0.00	458.00	14.70	6.90	20.00	LD_Mix	HDT_Mix	HHDT
Site Preparation	7	18.00	0.00	0.00	14.70	6.90	20.00	LD_Mix	HDT_Mix	HHDT
Grading	8	20.00	0.00	0.00	14.70	6.90	20.00	LD_Mix	HDT_Mix	HHDT
Building Construction	9	801.00	143.00	0.00	14.70	6.90	20.00	LD_Mix	HDT_Mix	HHDT
Paving	6	15.00	0.00	0.00	14.70	6.90	20.00	LD_Mix	HDT_Mix	HHDT
Architectural Coating	1	160.00	0.00	0.00	14.70	6.90	20.00	LD_Mix	HDT_Mix	HHDT

3.1 Mitigation Measures Construction

3.2 Demolition - 2021

Unmitigated Construction On-Site

	ROG	NOx	CO	SO2	Fugitive PM10	Exhaust PM10	PM10 Total	Fugitive PM2.5	Exhaust PM2.5	PM2.5 Total	Bio- CO2	NBio- CO2	Total CO2	CH4	N2O	CO2e
Category	lb/day										lb/day					
Fugitive Dust					3.3074	0.0000	3.3074	0.5008	0.0000	0.5008			0.0000			0.0000
Off-Road	3.1651	31.4407	21.5650	0.0388		1.5513	1.5513		1.4411	1.4411		3,747.9449	3,747.9449	1.0549		3,774.3174
Total	3.1651	31.4407	21.5650	0.0388	3.3074	1.5513	4.8588	0.5008	1.4411	1.9419		3,747.9449	3,747.9449	1.0549		3,774.3174

Village South Specific Plan (Proposed) - Los Angeles-South Coast County, Winter

3.2 Demolition - 2021

Unmitigated Construction Off-Site

	ROG	NOx	CO	SO2	Fugitive PM10	Exhaust PM10	PM10 Total	Fugitive PM2.5	Exhaust PM2.5	PM2.5 Total	Bio- CO2	NBio- CO2	Total CO2	CH4	N2O	CO2e
Category	lb/day										lb/day					
Hauling	0.1304	4.1454	1.0182	0.0117	0.2669	0.0128	0.2797	0.0732	0.0122	0.0854		1,269.8555	1,269.8555	0.0908		1,272.1252
Vendor	0.0000	0.0000	0.0000	0.0000	0.0000	0.0000	0.0000	0.0000	0.0000	0.0000		0.0000	0.0000	0.0000		0.0000
Worker	0.0715	0.0489	0.5524	1.6100e-003	0.1677	1.3500e-003	0.1690	0.0445	1.2500e-003	0.0457		160.8377	160.8377	4.7300e-003		160.9560
Total	0.2019	4.1943	1.5706	0.0133	0.4346	0.0141	0.4487	0.1176	0.0135	0.1311		1,430.6932	1,430.6932	0.0955		1,433.0812

Mitigated Construction On-Site

	ROG	NOx	CO	SO2	Fugitive PM10	Exhaust PM10	PM10 Total	Fugitive PM2.5	Exhaust PM2.5	PM2.5 Total	Bio- CO2	NBio- CO2	Total CO2	CH4	N2O	CO2e
Category	lb/day										lb/day					
Fugitive Dust					3.3074	0.0000	3.3074	0.5008	0.0000	0.5008			0.0000			0.0000
Off-Road	3.1651	31.4407	21.5650	0.0388		1.5513	1.5513		1.4411	1.4411	0.0000	3,747.9449	3,747.9449	1.0549		3,774.3174
Total	3.1651	31.4407	21.5650	0.0388	3.3074	1.5513	4.8588	0.5008	1.4411	1.9419	0.0000	3,747.9449	3,747.9449	1.0549		3,774.3174

Village South Specific Plan (Proposed) - Los Angeles-South Coast County, Winter

3.2 Demolition - 2021

Mitigated Construction Off-Site

	ROG	NOx	CO	SO2	Fugitive PM10	Exhaust PM10	PM10 Total	Fugitive PM2.5	Exhaust PM2.5	PM2.5 Total	Bio- CO2	NBio- CO2	Total CO2	CH4	N2O	CO2e
Category	lb/day										lb/day					
Hauling	0.1304	4.1454	1.0182	0.0117	0.2669	0.0128	0.2797	0.0732	0.0122	0.0854		1,269.8555	1,269.8555	0.0908		1,272.1252
Vendor	0.0000	0.0000	0.0000	0.0000	0.0000	0.0000	0.0000	0.0000	0.0000	0.0000		0.0000	0.0000	0.0000		0.0000
Worker	0.0715	0.0489	0.5524	1.6100e-003	0.1677	1.3500e-003	0.1690	0.0445	1.2500e-003	0.0457		160.8377	160.8377	4.7300e-003		160.9560
Total	0.2019	4.1943	1.5706	0.0133	0.4346	0.0141	0.4487	0.1176	0.0135	0.1311		1,430.6932	1,430.6932	0.0955		1,433.0812

3.3 Site Preparation - 2021

Unmitigated Construction On-Site

	ROG	NOx	CO	SO2	Fugitive PM10	Exhaust PM10	PM10 Total	Fugitive PM2.5	Exhaust PM2.5	PM2.5 Total	Bio- CO2	NBio- CO2	Total CO2	CH4	N2O	CO2e
Category	lb/day										lb/day					
Fugitive Dust					18.0663	0.0000	18.0663	9.9307	0.0000	9.9307			0.0000			0.0000
Off-Road	3.8882	40.4971	21.1543	0.0380		2.0445	2.0445		1.8809	1.8809		3,685.6569	3,685.6569	1.1920		3,715.4573
Total	3.8882	40.4971	21.1543	0.0380	18.0663	2.0445	20.1107	9.9307	1.8809	11.8116		3,685.6569	3,685.6569	1.1920		3,715.4573

Village South Specific Plan (Proposed) - Los Angeles-South Coast County, Winter

3.3 Site Preparation - 2021

Unmitigated Construction Off-Site

	ROG	NOx	CO	SO2	Fugitive PM10	Exhaust PM10	PM10 Total	Fugitive PM2.5	Exhaust PM2.5	PM2.5 Total	Bio- CO2	NBio- CO2	Total CO2	CH4	N2O	CO2e
Category	lb/day										lb/day					
Hauling	0.0000	0.0000	0.0000	0.0000	0.0000	0.0000	0.0000	0.0000	0.0000	0.0000		0.0000	0.0000	0.0000		0.0000
Vendor	0.0000	0.0000	0.0000	0.0000	0.0000	0.0000	0.0000	0.0000	0.0000	0.0000		0.0000	0.0000	0.0000		0.0000
Worker	0.0858	0.0587	0.6629	1.9400e-003	0.2012	1.6300e-003	0.2028	0.0534	1.5000e-003	0.0549		193.0052	193.0052	5.6800e-003		193.1472
Total	0.0858	0.0587	0.6629	1.9400e-003	0.2012	1.6300e-003	0.2028	0.0534	1.5000e-003	0.0549		193.0052	193.0052	5.6800e-003		193.1472

Mitigated Construction On-Site

	ROG	NOx	CO	SO2	Fugitive PM10	Exhaust PM10	PM10 Total	Fugitive PM2.5	Exhaust PM2.5	PM2.5 Total	Bio- CO2	NBio- CO2	Total CO2	CH4	N2O	CO2e
Category	lb/day										lb/day					
Fugitive Dust					18.0663	0.0000	18.0663	9.9307	0.0000	9.9307			0.0000			0.0000
Off-Road	3.8882	40.4971	21.1543	0.0380		2.0445	2.0445		1.8809	1.8809	0.0000	3,685.6569	3,685.6569	1.1920		3,715.4573
Total	3.8882	40.4971	21.1543	0.0380	18.0663	2.0445	20.1107	9.9307	1.8809	11.8116	0.0000	3,685.6569	3,685.6569	1.1920		3,715.4573

Village South Specific Plan (Proposed) - Los Angeles-South Coast County, Winter

3.3 Site Preparation - 2021

Mitigated Construction Off-Site

	ROG	NOx	CO	SO2	Fugitive PM10	Exhaust PM10	PM10 Total	Fugitive PM2.5	Exhaust PM2.5	PM2.5 Total	Bio- CO2	NBio- CO2	Total CO2	CH4	N2O	CO2e
Category	lb/day										lb/day					
Hauling	0.0000	0.0000	0.0000	0.0000	0.0000	0.0000	0.0000	0.0000	0.0000	0.0000		0.0000	0.0000	0.0000		0.0000
Vendor	0.0000	0.0000	0.0000	0.0000	0.0000	0.0000	0.0000	0.0000	0.0000	0.0000		0.0000	0.0000	0.0000		0.0000
Worker	0.0858	0.0587	0.6629	1.9400e-003	0.2012	1.6300e-003	0.2028	0.0534	1.5000e-003	0.0549		193.0052	193.0052	5.6800e-003		193.1472
Total	0.0858	0.0587	0.6629	1.9400e-003	0.2012	1.6300e-003	0.2028	0.0534	1.5000e-003	0.0549		193.0052	193.0052	5.6800e-003		193.1472

3.4 Grading - 2021

Unmitigated Construction On-Site

	ROG	NOx	CO	SO2	Fugitive PM10	Exhaust PM10	PM10 Total	Fugitive PM2.5	Exhaust PM2.5	PM2.5 Total	Bio- CO2	NBio- CO2	Total CO2	CH4	N2O	CO2e
Category	lb/day										lb/day					
Fugitive Dust					8.6733	0.0000	8.6733	3.5965	0.0000	3.5965			0.0000			0.0000
Off-Road	4.1912	46.3998	30.8785	0.0620		1.9853	1.9853		1.8265	1.8265		6,007.0434	6,007.0434	1.9428		6,055.6134
Total	4.1912	46.3998	30.8785	0.0620	8.6733	1.9853	10.6587	3.5965	1.8265	5.4230		6,007.0434	6,007.0434	1.9428		6,055.6134

Village South Specific Plan (Proposed) - Los Angeles-South Coast County, Winter

3.4 Grading - 2021

Unmitigated Construction Off-Site

	ROG	NOx	CO	SO2	Fugitive PM10	Exhaust PM10	PM10 Total	Fugitive PM2.5	Exhaust PM2.5	PM2.5 Total	Bio- CO2	NBio- CO2	Total CO2	CH4	N2O	CO2e
Category	lb/day										lb/day					
Hauling	0.0000	0.0000	0.0000	0.0000	0.0000	0.0000	0.0000	0.0000	0.0000	0.0000		0.0000	0.0000	0.0000		0.0000
Vendor	0.0000	0.0000	0.0000	0.0000	0.0000	0.0000	0.0000	0.0000	0.0000	0.0000		0.0000	0.0000	0.0000		0.0000
Worker	0.0954	0.0652	0.7365	2.1500e-003	0.2236	1.8100e-003	0.2254	0.0593	1.6600e-003	0.0610		214.4502	214.4502	6.3100e-003		214.6080
Total	0.0954	0.0652	0.7365	2.1500e-003	0.2236	1.8100e-003	0.2254	0.0593	1.6600e-003	0.0610		214.4502	214.4502	6.3100e-003		214.6080

Mitigated Construction On-Site

	ROG	NOx	CO	SO2	Fugitive PM10	Exhaust PM10	PM10 Total	Fugitive PM2.5	Exhaust PM2.5	PM2.5 Total	Bio- CO2	NBio- CO2	Total CO2	CH4	N2O	CO2e
Category	lb/day										lb/day					
Fugitive Dust					8.6733	0.0000	8.6733	3.5965	0.0000	3.5965			0.0000			0.0000
Off-Road	4.1912	46.3998	30.8785	0.0620		1.9853	1.9853		1.8265	1.8265	0.0000	6,007.0434	6,007.0434	1.9428		6,055.6134
Total	4.1912	46.3998	30.8785	0.0620	8.6733	1.9853	10.6587	3.5965	1.8265	5.4230	0.0000	6,007.0434	6,007.0434	1.9428		6,055.6134

Village South Specific Plan (Proposed) - Los Angeles-South Coast County, Winter

3.4 Grading - 2021

Mitigated Construction Off-Site

	ROG	NOx	CO	SO2	Fugitive PM10	Exhaust PM10	PM10 Total	Fugitive PM2.5	Exhaust PM2.5	PM2.5 Total	Bio- CO2	NBio- CO2	Total CO2	CH4	N2O	CO2e
Category	lb/day										lb/day					
Hauling	0.0000	0.0000	0.0000	0.0000	0.0000	0.0000	0.0000	0.0000	0.0000	0.0000		0.0000	0.0000	0.0000		0.0000
Vendor	0.0000	0.0000	0.0000	0.0000	0.0000	0.0000	0.0000	0.0000	0.0000	0.0000		0.0000	0.0000	0.0000		0.0000
Worker	0.0954	0.0652	0.7365	2.1500e-003	0.2236	1.8100e-003	0.2254	0.0593	1.6600e-003	0.0610		214.4502	214.4502	6.3100e-003		214.6080
Total	0.0954	0.0652	0.7365	2.1500e-003	0.2236	1.8100e-003	0.2254	0.0593	1.6600e-003	0.0610		214.4502	214.4502	6.3100e-003		214.6080

3.4 Grading - 2022

Unmitigated Construction On-Site

	ROG	NOx	CO	SO2	Fugitive PM10	Exhaust PM10	PM10 Total	Fugitive PM2.5	Exhaust PM2.5	PM2.5 Total	Bio- CO2	NBio- CO2	Total CO2	CH4	N2O	CO2e
Category	lb/day										lb/day					
Fugitive Dust					8.6733	0.0000	8.6733	3.5965	0.0000	3.5965			0.0000			0.0000
Off-Road	3.6248	38.8435	29.0415	0.0621		1.6349	1.6349		1.5041	1.5041		6,011.4105	6,011.4105	1.9442		6,060.0158
Total	3.6248	38.8435	29.0415	0.0621	8.6733	1.6349	10.3082	3.5965	1.5041	5.1006		6,011.4105	6,011.4105	1.9442		6,060.0158

Village South Specific Plan (Proposed) - Los Angeles-South Coast County, Winter

3.4 Grading - 2022

Unmitigated Construction Off-Site

	ROG	NOx	CO	SO2	Fugitive PM10	Exhaust PM10	PM10 Total	Fugitive PM2.5	Exhaust PM2.5	PM2.5 Total	Bio- CO2	NBio- CO2	Total CO2	CH4	N2O	CO2e
Category	lb/day										lb/day					
Hauling	0.0000	0.0000	0.0000	0.0000	0.0000	0.0000	0.0000	0.0000	0.0000	0.0000		0.0000	0.0000	0.0000		0.0000
Vendor	0.0000	0.0000	0.0000	0.0000	0.0000	0.0000	0.0000	0.0000	0.0000	0.0000		0.0000	0.0000	0.0000		0.0000
Worker	0.0896	0.0589	0.6784	2.0800e-003	0.2236	1.7500e-003	0.2253	0.0593	1.6100e-003	0.0609		206.9139	206.9139	5.7000e-003		207.0563
Total	0.0896	0.0589	0.6784	2.0800e-003	0.2236	1.7500e-003	0.2253	0.0593	1.6100e-003	0.0609		206.9139	206.9139	5.7000e-003		207.0563

Mitigated Construction On-Site

	ROG	NOx	CO	SO2	Fugitive PM10	Exhaust PM10	PM10 Total	Fugitive PM2.5	Exhaust PM2.5	PM2.5 Total	Bio- CO2	NBio- CO2	Total CO2	CH4	N2O	CO2e
Category	lb/day										lb/day					
Fugitive Dust					8.6733	0.0000	8.6733	3.5965	0.0000	3.5965			0.0000			0.0000
Off-Road	3.6248	38.8435	29.0415	0.0621		1.6349	1.6349		1.5041	1.5041	0.0000	6,011.4105	6,011.4105	1.9442		6,060.0158
Total	3.6248	38.8435	29.0415	0.0621	8.6733	1.6349	10.3082	3.5965	1.5041	5.1006	0.0000	6,011.4105	6,011.4105	1.9442		6,060.0158

Village South Specific Plan (Proposed) - Los Angeles-South Coast County, Winter

3.4 Grading - 2022

Mitigated Construction Off-Site

	ROG	NOx	CO	SO2	Fugitive PM10	Exhaust PM10	PM10 Total	Fugitive PM2.5	Exhaust PM2.5	PM2.5 Total	Bio- CO2	NBio- CO2	Total CO2	CH4	N2O	CO2e
Category	lb/day										lb/day					
Hauling	0.0000	0.0000	0.0000	0.0000	0.0000	0.0000	0.0000	0.0000	0.0000	0.0000		0.0000	0.0000	0.0000		0.0000
Vendor	0.0000	0.0000	0.0000	0.0000	0.0000	0.0000	0.0000	0.0000	0.0000	0.0000		0.0000	0.0000	0.0000		0.0000
Worker	0.0896	0.0589	0.6784	2.0800e-003	0.2236	1.7500e-003	0.2253	0.0593	1.6100e-003	0.0609		206.9139	206.9139	5.7000e-003		207.0563
Total	0.0896	0.0589	0.6784	2.0800e-003	0.2236	1.7500e-003	0.2253	0.0593	1.6100e-003	0.0609		206.9139	206.9139	5.7000e-003		207.0563

3.5 Building Construction - 2022

Unmitigated Construction On-Site

	ROG	NOx	CO	SO2	Fugitive PM10	Exhaust PM10	PM10 Total	Fugitive PM2.5	Exhaust PM2.5	PM2.5 Total	Bio- CO2	NBio- CO2	Total CO2	CH4	N2O	CO2e
Category	lb/day										lb/day					
Off-Road	1.7062	15.6156	16.3634	0.0269		0.8090	0.8090		0.7612	0.7612		2,554.3336	2,554.3336	0.6120		2,569.6322
Total	1.7062	15.6156	16.3634	0.0269		0.8090	0.8090		0.7612	0.7612		2,554.3336	2,554.3336	0.6120		2,569.6322

Village South Specific Plan (Proposed) - Los Angeles-South Coast County, Winter

3.5 Building Construction - 2022

Unmitigated Construction Off-Site

	ROG	NOx	CO	SO2	Fugitive PM10	Exhaust PM10	PM10 Total	Fugitive PM2.5	Exhaust PM2.5	PM2.5 Total	Bio- CO2	NBio- CO2	Total CO2	CH4	N2O	CO2e
Category	lb/day										lb/day					
Hauling	0.0000	0.0000	0.0000	0.0000	0.0000	0.0000	0.0000	0.0000	0.0000	0.0000		0.0000	0.0000	0.0000		0.0000
Vendor	0.4284	13.1673	3.8005	0.0354	0.9155	0.0256	0.9412	0.2636	0.0245	0.2881		3,789.0750	3,789.0750	0.2381		3,795.0283
Worker	3.5872	2.3593	27.1680	0.0832	8.9533	0.0701	9.0234	2.3745	0.0646	2.4390		8,286.9013	8,286.9013	0.2282		8,292.6058
Total	4.0156	15.5266	30.9685	0.1186	9.8688	0.0957	9.9645	2.6381	0.0891	2.7271		12,075.9763	12,075.9763	0.4663		12,087.6341

Mitigated Construction On-Site

	ROG	NOx	CO	SO2	Fugitive PM10	Exhaust PM10	PM10 Total	Fugitive PM2.5	Exhaust PM2.5	PM2.5 Total	Bio- CO2	NBio- CO2	Total CO2	CH4	N2O	CO2e
Category	lb/day										lb/day					
Off-Road	1.7062	15.6156	16.3634	0.0269		0.8090	0.8090		0.7612	0.7612	0.0000	2,554.3336	2,554.3336	0.6120		2,569.6322
Total	1.7062	15.6156	16.3634	0.0269		0.8090	0.8090		0.7612	0.7612	0.0000	2,554.3336	2,554.3336	0.6120		2,569.6322

Village South Specific Plan (Proposed) - Los Angeles-South Coast County, Winter

3.5 Building Construction - 2022

Mitigated Construction Off-Site

	ROG	NOx	CO	SO2	Fugitive PM10	Exhaust PM10	PM10 Total	Fugitive PM2.5	Exhaust PM2.5	PM2.5 Total	Bio- CO2	NBio- CO2	Total CO2	CH4	N2O	CO2e
Category	lb/day										lb/day					
Hauling	0.0000	0.0000	0.0000	0.0000	0.0000	0.0000	0.0000	0.0000	0.0000	0.0000		0.0000	0.0000	0.0000		0.0000
Vendor	0.4284	13.1673	3.8005	0.0354	0.9155	0.0256	0.9412	0.2636	0.0245	0.2881		3,789.0750	3,789.0750	0.2381		3,795.0283
Worker	3.5872	2.3593	27.1680	0.0832	8.9533	0.0701	9.0234	2.3745	0.0646	2.4390		8,286.9013	8,286.9013	0.2282		8,292.6058
Total	4.0156	15.5266	30.9685	0.1186	9.8688	0.0957	9.9645	2.6381	0.0891	2.7271		12,075.9763	12,075.9763	0.4663		12,087.6341

3.5 Building Construction - 2023

Unmitigated Construction On-Site

	ROG	NOx	CO	SO2	Fugitive PM10	Exhaust PM10	PM10 Total	Fugitive PM2.5	Exhaust PM2.5	PM2.5 Total	Bio- CO2	NBio- CO2	Total CO2	CH4	N2O	CO2e
Category	lb/day										lb/day					
Off-Road	1.5728	14.3849	16.2440	0.0269		0.6997	0.6997		0.6584	0.6584		2,555.2099	2,555.2099	0.6079		2,570.4061
Total	1.5728	14.3849	16.2440	0.0269		0.6997	0.6997		0.6584	0.6584		2,555.2099	2,555.2099	0.6079		2,570.4061

Village South Specific Plan (Proposed) - Los Angeles-South Coast County, Winter

3.5 Building Construction - 2023

Unmitigated Construction Off-Site

	ROG	NOx	CO	SO2	Fugitive PM10	Exhaust PM10	PM10 Total	Fugitive PM2.5	Exhaust PM2.5	PM2.5 Total	Bio- CO2	NBio- CO2	Total CO2	CH4	N2O	CO2e
Category	lb/day										lb/day					
Hauling	0.0000	0.0000	0.0000	0.0000	0.0000	0.0000	0.0000	0.0000	0.0000	0.0000		0.0000	0.0000	0.0000		0.0000
Vendor	0.3183	9.9726	3.3771	0.0343	0.9156	0.0122	0.9277	0.2636	0.0116	0.2752		3,671.4007	3,671.4007	0.2096		3,676.6417
Worker	3.3795	2.1338	24.9725	0.0801	8.9533	0.0681	9.0214	2.3745	0.0627	2.4372		7,983.7318	7,983.7318	0.2055		7,988.8683
Total	3.6978	12.1065	28.3496	0.1144	9.8688	0.0803	9.9491	2.6381	0.0743	2.7124		11,655.1325	11,655.1325	0.4151		11,665.5099

Mitigated Construction On-Site

	ROG	NOx	CO	SO2	Fugitive PM10	Exhaust PM10	PM10 Total	Fugitive PM2.5	Exhaust PM2.5	PM2.5 Total	Bio- CO2	NBio- CO2	Total CO2	CH4	N2O	CO2e
Category	lb/day										lb/day					
Off-Road	1.5728	14.3849	16.2440	0.0269		0.6997	0.6997		0.6584	0.6584	0.0000	2,555.2099	2,555.2099	0.6079		2,570.4061
Total	1.5728	14.3849	16.2440	0.0269		0.6997	0.6997		0.6584	0.6584	0.0000	2,555.2099	2,555.2099	0.6079		2,570.4061

Village South Specific Plan (Proposed) - Los Angeles-South Coast County, Winter

3.5 Building Construction - 2023

Mitigated Construction Off-Site

	ROG	NOx	CO	SO2	Fugitive PM10	Exhaust PM10	PM10 Total	Fugitive PM2.5	Exhaust PM2.5	PM2.5 Total	Bio- CO2	NBio- CO2	Total CO2	CH4	N2O	CO2e
Category	lb/day										lb/day					
Hauling	0.0000	0.0000	0.0000	0.0000	0.0000	0.0000	0.0000	0.0000	0.0000	0.0000		0.0000	0.0000	0.0000		0.0000
Vendor	0.3183	9.9726	3.3771	0.0343	0.9156	0.0122	0.9277	0.2636	0.0116	0.2752		3,671.4007	3,671.4007	0.2096		3,676.6417
Worker	3.3795	2.1338	24.9725	0.0801	8.9533	0.0681	9.0214	2.3745	0.0627	2.4372		7,983.7318	7,983.7318	0.2055		7,988.8683
Total	3.6978	12.1065	28.3496	0.1144	9.8688	0.0803	9.9491	2.6381	0.0743	2.7124		11,655.1325	11,655.1325	0.4151		11,665.5099

3.6 Paving - 2023

Unmitigated Construction On-Site

	ROG	NOx	CO	SO2	Fugitive PM10	Exhaust PM10	PM10 Total	Fugitive PM2.5	Exhaust PM2.5	PM2.5 Total	Bio- CO2	NBio- CO2	Total CO2	CH4	N2O	CO2e
Category	lb/day										lb/day					
Off-Road	1.0327	10.1917	14.5842	0.0228		0.5102	0.5102		0.4694	0.4694		2,207.5841	2,207.5841	0.7140		2,225.4336
Paving	0.0000					0.0000	0.0000		0.0000	0.0000			0.0000			0.0000
Total	1.0327	10.1917	14.5842	0.0228		0.5102	0.5102		0.4694	0.4694		2,207.5841	2,207.5841	0.7140		2,225.4336

Village South Specific Plan (Proposed) - Los Angeles-South Coast County, Winter

3.6 Paving - 2023

Unmitigated Construction Off-Site

	ROG	NOx	CO	SO2	Fugitive PM10	Exhaust PM10	PM10 Total	Fugitive PM2.5	Exhaust PM2.5	PM2.5 Total	Bio- CO2	NBio- CO2	Total CO2	CH4	N2O	CO2e
Category	lb/day										lb/day					
Hauling	0.0000	0.0000	0.0000	0.0000	0.0000	0.0000	0.0000	0.0000	0.0000	0.0000		0.0000	0.0000	0.0000		0.0000
Vendor	0.0000	0.0000	0.0000	0.0000	0.0000	0.0000	0.0000	0.0000	0.0000	0.0000		0.0000	0.0000	0.0000		0.0000
Worker	0.0633	0.0400	0.4677	1.5000e-003	0.1677	1.2800e-003	0.1689	0.0445	1.1700e-003	0.0456		149.5081	149.5081	3.8500e-003		149.6043
Total	0.0633	0.0400	0.4677	1.5000e-003	0.1677	1.2800e-003	0.1689	0.0445	1.1700e-003	0.0456		149.5081	149.5081	3.8500e-003		149.6043

Mitigated Construction On-Site

	ROG	NOx	CO	SO2	Fugitive PM10	Exhaust PM10	PM10 Total	Fugitive PM2.5	Exhaust PM2.5	PM2.5 Total	Bio- CO2	NBio- CO2	Total CO2	CH4	N2O	CO2e
Category	lb/day										lb/day					
Off-Road	1.0327	10.1917	14.5842	0.0228		0.5102	0.5102		0.4694	0.4694	0.0000	2,207.5841	2,207.5841	0.7140		2,225.4336
Paving	0.0000					0.0000	0.0000		0.0000	0.0000			0.0000			0.0000
Total	1.0327	10.1917	14.5842	0.0228		0.5102	0.5102		0.4694	0.4694	0.0000	2,207.5841	2,207.5841	0.7140		2,225.4336

Village South Specific Plan (Proposed) - Los Angeles-South Coast County, Winter

3.6 Paving - 2023

Mitigated Construction Off-Site

	ROG	NOx	CO	SO2	Fugitive PM10	Exhaust PM10	PM10 Total	Fugitive PM2.5	Exhaust PM2.5	PM2.5 Total	Bio- CO2	NBio- CO2	Total CO2	CH4	N2O	CO2e
Category	lb/day										lb/day					
Hauling	0.0000	0.0000	0.0000	0.0000	0.0000	0.0000	0.0000	0.0000	0.0000	0.0000		0.0000	0.0000	0.0000		0.0000
Vendor	0.0000	0.0000	0.0000	0.0000	0.0000	0.0000	0.0000	0.0000	0.0000	0.0000		0.0000	0.0000	0.0000		0.0000
Worker	0.0633	0.0400	0.4677	1.5000e-003	0.1677	1.2800e-003	0.1689	0.0445	1.1700e-003	0.0456		149.5081	149.5081	3.8500e-003		149.6043
Total	0.0633	0.0400	0.4677	1.5000e-003	0.1677	1.2800e-003	0.1689	0.0445	1.1700e-003	0.0456		149.5081	149.5081	3.8500e-003		149.6043

3.6 Paving - 2024

Unmitigated Construction On-Site

	ROG	NOx	CO	SO2	Fugitive PM10	Exhaust PM10	PM10 Total	Fugitive PM2.5	Exhaust PM2.5	PM2.5 Total	Bio- CO2	NBio- CO2	Total CO2	CH4	N2O	CO2e
Category	lb/day										lb/day					
Off-Road	0.9882	9.5246	14.6258	0.0228		0.4685	0.4685		0.4310	0.4310		2,207.5472	2,207.5472	0.7140		2,225.3963
Paving	0.0000					0.0000	0.0000		0.0000	0.0000			0.0000			0.0000
Total	0.9882	9.5246	14.6258	0.0228		0.4685	0.4685		0.4310	0.4310		2,207.5472	2,207.5472	0.7140		2,225.3963

Village South Specific Plan (Proposed) - Los Angeles-South Coast County, Winter

3.6 Paving - 2024

Unmitigated Construction Off-Site

	ROG	NOx	CO	SO2	Fugitive PM10	Exhaust PM10	PM10 Total	Fugitive PM2.5	Exhaust PM2.5	PM2.5 Total	Bio- CO2	NBio- CO2	Total CO2	CH4	N2O	CO2e
Category	lb/day										lb/day					
Hauling	0.0000	0.0000	0.0000	0.0000	0.0000	0.0000	0.0000	0.0000	0.0000	0.0000		0.0000	0.0000	0.0000		0.0000
Vendor	0.0000	0.0000	0.0000	0.0000	0.0000	0.0000	0.0000	0.0000	0.0000	0.0000		0.0000	0.0000	0.0000		0.0000
Worker	0.0601	0.0364	0.4354	1.4500e-003	0.1677	1.2600e-003	0.1689	0.0445	1.1600e-003	0.0456		144.8706	144.8706	3.5300e-003		144.9587
Total	0.0601	0.0364	0.4354	1.4500e-003	0.1677	1.2600e-003	0.1689	0.0445	1.1600e-003	0.0456		144.8706	144.8706	3.5300e-003		144.9587

Mitigated Construction On-Site

	ROG	NOx	CO	SO2	Fugitive PM10	Exhaust PM10	PM10 Total	Fugitive PM2.5	Exhaust PM2.5	PM2.5 Total	Bio- CO2	NBio- CO2	Total CO2	CH4	N2O	CO2e
Category	lb/day										lb/day					
Off-Road	0.9882	9.5246	14.6258	0.0228		0.4685	0.4685		0.4310	0.4310	0.0000	2,207.5472	2,207.5472	0.7140		2,225.3963
Paving	0.0000					0.0000	0.0000		0.0000	0.0000			0.0000			0.0000
Total	0.9882	9.5246	14.6258	0.0228		0.4685	0.4685		0.4310	0.4310	0.0000	2,207.5472	2,207.5472	0.7140		2,225.3963

Village South Specific Plan (Proposed) - Los Angeles-South Coast County, Winter

3.6 Paving - 2024

Mitigated Construction Off-Site

	ROG	NOx	CO	SO2	Fugitive PM10	Exhaust PM10	PM10 Total	Fugitive PM2.5	Exhaust PM2.5	PM2.5 Total	Bio- CO2	NBio- CO2	Total CO2	CH4	N2O	CO2e
Category	lb/day										lb/day					
Hauling	0.0000	0.0000	0.0000	0.0000	0.0000	0.0000	0.0000	0.0000	0.0000	0.0000		0.0000	0.0000	0.0000		0.0000
Vendor	0.0000	0.0000	0.0000	0.0000	0.0000	0.0000	0.0000	0.0000	0.0000	0.0000		0.0000	0.0000	0.0000		0.0000
Worker	0.0601	0.0364	0.4354	1.4500e-003	0.1677	1.2600e-003	0.1689	0.0445	1.1600e-003	0.0456		144.8706	144.8706	3.5300e-003		144.9587
Total	0.0601	0.0364	0.4354	1.4500e-003	0.1677	1.2600e-003	0.1689	0.0445	1.1600e-003	0.0456		144.8706	144.8706	3.5300e-003		144.9587

3.7 Architectural Coating - 2024

Unmitigated Construction On-Site

	ROG	NOx	CO	SO2	Fugitive PM10	Exhaust PM10	PM10 Total	Fugitive PM2.5	Exhaust PM2.5	PM2.5 Total	Bio- CO2	NBio- CO2	Total CO2	CH4	N2O	CO2e
Category	lb/day										lb/day					
Archit. Coating	236.4115					0.0000	0.0000		0.0000	0.0000			0.0000			0.0000
Off-Road	0.1808	1.2188	1.8101	2.9700e-003		0.0609	0.0609		0.0609	0.0609		281.4481	281.4481	0.0159		281.8443
Total	236.5923	1.2188	1.8101	2.9700e-003		0.0609	0.0609		0.0609	0.0609		281.4481	281.4481	0.0159		281.8443

Village South Specific Plan (Proposed) - Los Angeles-South Coast County, Winter

3.7 Architectural Coating - 2024

Unmitigated Construction Off-Site

	ROG	NOx	CO	SO2	Fugitive PM10	Exhaust PM10	PM10 Total	Fugitive PM2.5	Exhaust PM2.5	PM2.5 Total	Bio- CO2	NBio- CO2	Total CO2	CH4	N2O	CO2e
Category	lb/day										lb/day					
Hauling	0.0000	0.0000	0.0000	0.0000	0.0000	0.0000	0.0000	0.0000	0.0000	0.0000		0.0000	0.0000	0.0000		0.0000
Vendor	0.0000	0.0000	0.0000	0.0000	0.0000	0.0000	0.0000	0.0000	0.0000	0.0000		0.0000	0.0000	0.0000		0.0000
Worker	0.6406	0.3886	4.6439	0.0155	1.7884	0.0134	1.8018	0.4743	0.0123	0.4866		1,545.2860	1,545.2860	0.0376		1,546.2262
Total	0.6406	0.3886	4.6439	0.0155	1.7884	0.0134	1.8018	0.4743	0.0123	0.4866		1,545.2860	1,545.2860	0.0376		1,546.2262

Mitigated Construction On-Site

	ROG	NOx	CO	SO2	Fugitive PM10	Exhaust PM10	PM10 Total	Fugitive PM2.5	Exhaust PM2.5	PM2.5 Total	Bio- CO2	NBio- CO2	Total CO2	CH4	N2O	CO2e
Category	lb/day										lb/day					
Archit. Coating	236.4115					0.0000	0.0000		0.0000	0.0000			0.0000			0.0000
Off-Road	0.1808	1.2188	1.8101	2.9700e-003		0.0609	0.0609		0.0609	0.0609	0.0000	281.4481	281.4481	0.0159		281.8443
Total	236.5923	1.2188	1.8101	2.9700e-003		0.0609	0.0609		0.0609	0.0609	0.0000	281.4481	281.4481	0.0159		281.8443

Village South Specific Plan (Proposed) - Los Angeles-South Coast County, Winter

3.7 Architectural Coating - 2024

Mitigated Construction Off-Site

	ROG	NOx	CO	SO2	Fugitive PM10	Exhaust PM10	PM10 Total	Fugitive PM2.5	Exhaust PM2.5	PM2.5 Total	Bio- CO2	NBio- CO2	Total CO2	CH4	N2O	CO2e
Category	lb/day										lb/day					
Hauling	0.0000	0.0000	0.0000	0.0000	0.0000	0.0000	0.0000	0.0000	0.0000	0.0000		0.0000	0.0000	0.0000		0.0000
Vendor	0.0000	0.0000	0.0000	0.0000	0.0000	0.0000	0.0000	0.0000	0.0000	0.0000		0.0000	0.0000	0.0000		0.0000
Worker	0.6406	0.3886	4.6439	0.0155	1.7884	0.0134	1.8018	0.4743	0.0123	0.4866		1,545.2860	1,545.2860	0.0376		1,546.2262
Total	0.6406	0.3886	4.6439	0.0155	1.7884	0.0134	1.8018	0.4743	0.0123	0.4866		1,545.2860	1,545.2860	0.0376		1,546.2262

4.0 Operational Detail - Mobile

4.1 Mitigation Measures Mobile

Village South Specific Plan (Proposed) - Los Angeles-South Coast County, Winter

	ROG	NOx	CO	SO2	Fugitive PM10	Exhaust PM10	PM10 Total	Fugitive PM2.5	Exhaust PM2.5	PM2.5 Total	Bio- CO2	NBio- CO2	Total CO2	CH4	N2O	CO2e
Category	lb/day										lb/day					
Mitigated	9.5233	45.9914	110.0422	0.4681	45.9592	0.3373	46.2965	12.2950	0.3132	12.6083		47,917.8005	47,917.8005	2.1953		47,972.6839
Unmitigated	9.5233	45.9914	110.0422	0.4681	45.9592	0.3373	46.2965	12.2950	0.3132	12.6083		47,917.8005	47,917.8005	2.1953		47,972.6839

4.2 Trip Summary Information

Land Use	Average Daily Trip Rate			Unmitigated	Mitigated
	Weekday	Saturday	Sunday	Annual VMT	Annual VMT
Apartments Low Rise	145.75	154.25	154.00	506,227	506,227
Apartments Mid Rise	4,026.75	3,773.25	4075.50	13,660,065	13,660,065
General Office Building	288.45	62.55	31.05	706,812	706,812
High Turnover (Sit Down Restaurant)	2,368.80	2,873.52	2817.72	3,413,937	3,413,937
Hotel	192.00	187.50	160.00	445,703	445,703
Quality Restaurant	501.12	511.92	461.20	707,488	707,488
Regional Shopping Center	528.08	601.44	357.84	1,112,221	1,112,221
Total	8,050.95	8,164.43	8,057.31	20,552,452	20,552,452

4.3 Trip Type Information

Village South Specific Plan (Proposed) - Los Angeles-South Coast County, Winter

Land Use	Miles			Trip %			Trip Purpose %		
	H-W or C-W	H-S or C-C	H-O or C-NW	H-W or C-W	H-S or C-C	H-O or C-NW	Primary	Diverted	Pass-by
Apartments Low Rise	14.70	5.90	8.70	40.20	19.20	40.60	86	11	3
Apartments Mid Rise	14.70	5.90	8.70	40.20	19.20	40.60	86	11	3
General Office Building	16.60	8.40	6.90	33.00	48.00	19.00	77	19	4
High Turnover (Sit Down Restaurant)	16.60	8.40	6.90	8.50	72.50	19.00	37	20	43
Hotel	16.60	8.40	6.90	19.40	61.60	19.00	58	38	4
Quality Restaurant	16.60	8.40	6.90	12.00	69.00	19.00	38	18	44
Regional Shopping Center	16.60	8.40	6.90	16.30	64.70	19.00	54	35	11

4.4 Fleet Mix

Land Use	LDA	LDT1	LDT2	MDV	LHD1	LHD2	MHD	HHD	OBUS	UBUS	MCY	SBUS	MH
Apartments Low Rise	0.543088	0.044216	0.209971	0.116369	0.014033	0.006332	0.021166	0.033577	0.002613	0.001817	0.005285	0.000712	0.000821
Apartments Mid Rise	0.543088	0.044216	0.209971	0.116369	0.014033	0.006332	0.021166	0.033577	0.002613	0.001817	0.005285	0.000712	0.000821
General Office Building	0.543088	0.044216	0.209971	0.116369	0.014033	0.006332	0.021166	0.033577	0.002613	0.001817	0.005285	0.000712	0.000821
High Turnover (Sit Down Restaurant)	0.543088	0.044216	0.209971	0.116369	0.014033	0.006332	0.021166	0.033577	0.002613	0.001817	0.005285	0.000712	0.000821
Hotel	0.543088	0.044216	0.209971	0.116369	0.014033	0.006332	0.021166	0.033577	0.002613	0.001817	0.005285	0.000712	0.000821
Quality Restaurant	0.543088	0.044216	0.209971	0.116369	0.014033	0.006332	0.021166	0.033577	0.002613	0.001817	0.005285	0.000712	0.000821
Regional Shopping Center	0.543088	0.044216	0.209971	0.116369	0.014033	0.006332	0.021166	0.033577	0.002613	0.001817	0.005285	0.000712	0.000821

5.0 Energy Detail

Historical Energy Use: N

5.1 Mitigation Measures Energy

Village South Specific Plan (Proposed) - Los Angeles-South Coast County, Winter

	ROG	NOx	CO	SO2	Fugitive PM10	Exhaust PM10	PM10 Total	Fugitive PM2.5	Exhaust PM2.5	PM2.5 Total	Bio- CO2	NBio- CO2	Total CO2	CH4	N2O	CO2e
Category	lb/day										lb/day					
NaturalGas Mitigated	0.7660	6.7462	4.2573	0.0418		0.5292	0.5292		0.5292	0.5292		8,355.983 2	8,355.983 2	0.1602	0.1532	8,405.638 7
NaturalGas Unmitigated	0.7660	6.7462	4.2573	0.0418		0.5292	0.5292		0.5292	0.5292		8,355.983 2	8,355.983 2	0.1602	0.1532	8,405.638 7

Village South Specific Plan (Proposed) - Los Angeles-South Coast County, Winter

5.2 Energy by Land Use - NaturalGas

Unmitigated

	NaturalGas Use	ROG	NOx	CO	SO2	Fugitive PM10	Exhaust PM10	PM10 Total	Fugitive PM2.5	Exhaust PM2.5	PM2.5 Total	Bio- CO2	NBio- CO2	Total CO2	CH4	N2O	CO2e
Land Use	kBTU/yr	lb/day										lb/day					
Apartments Low Rise	1119.16	0.0121	0.1031	0.0439	6.6000e-004		8.3400e-003	8.3400e-003		8.3400e-003	8.3400e-003		131.6662	131.6662	2.5200e-003	2.4100e-003	132.4486
Apartments Mid Rise	35784.3	0.3859	3.2978	1.4033	0.0211		0.2666	0.2666		0.2666	0.2666		4,209.9164	4,209.9164	0.0807	0.0772	4,234.9339
General Office Building	1283.42	0.0138	0.1258	0.1057	7.5000e-004		9.5600e-003	9.5600e-003		9.5600e-003	9.5600e-003		150.9911	150.9911	2.8900e-003	2.7700e-003	151.8884
High Turnover (Sit Down Restaurant)	22759.9	0.2455	2.2314	1.8743	0.0134		0.1696	0.1696		0.1696	0.1696		2,677.6342	2,677.6342	0.0513	0.0491	2,693.5460
Hotel	4769.72	0.0514	0.4676	0.3928	2.8100e-003		0.0355	0.0355		0.0355	0.0355		561.1436	561.1436	0.0108	0.0103	564.4782
Quality Restaurant	5057.75	0.0545	0.4959	0.4165	2.9800e-003		0.0377	0.0377		0.0377	0.0377		595.0298	595.0298	0.0114	0.0109	598.5658
Regional Shopping Center	251.616	2.7100e-003	0.0247	0.0207	1.5000e-004		1.8700e-003	1.8700e-003		1.8700e-003	1.8700e-003		29.6019	29.6019	5.7000e-004	5.4000e-004	29.7778
Total		0.7660	6.7463	4.2573	0.0418		0.5292	0.5292		0.5292	0.5292		8,355.9832	8,355.9832	0.1602	0.1532	8,405.6387

Village South Specific Plan (Proposed) - Los Angeles-South Coast County, Winter

5.2 Energy by Land Use - NaturalGas

Mitigated

	NaturalGas Use	ROG	NOx	CO	SO2	Fugitive PM10	Exhaust PM10	PM10 Total	Fugitive PM2.5	Exhaust PM2.5	PM2.5 Total	Bio- CO2	NBio- CO2	Total CO2	CH4	N2O	CO2e
Land Use	kBTU/yr	lb/day										lb/day					
Apartments Low Rise	1.11916	0.0121	0.1031	0.0439	6.6000e-004		8.3400e-003	8.3400e-003		8.3400e-003	8.3400e-003		131.6662	131.6662	2.5200e-003	2.4100e-003	132.4486
Apartments Mid Rise	35.7843	0.3859	3.2978	1.4033	0.0211		0.2666	0.2666		0.2666	0.2666		4,209.9164	4,209.9164	0.0807	0.0772	4,234.9339
General Office Building	1.28342	0.0138	0.1258	0.1057	7.5000e-004		9.5600e-003	9.5600e-003		9.5600e-003	9.5600e-003		150.9911	150.9911	2.8900e-003	2.7700e-003	151.8884
High Turnover (Sit Down Restaurant)	22.7599	0.2455	2.2314	1.8743	0.0134		0.1696	0.1696		0.1696	0.1696		2,677.6342	2,677.6342	0.0513	0.0491	2,693.5460
Hotel	4.76972	0.0514	0.4676	0.3928	2.8100e-003		0.0355	0.0355		0.0355	0.0355		561.1436	561.1436	0.0108	0.0103	564.4782
Quality Restaurant	5.05775	0.0545	0.4959	0.4165	2.9800e-003		0.0377	0.0377		0.0377	0.0377		595.0298	595.0298	0.0114	0.0109	598.5658
Regional Shopping Center	0.251616	2.7100e-003	0.0247	0.0207	1.5000e-004		1.8700e-003	1.8700e-003		1.8700e-003	1.8700e-003		29.6019	29.6019	5.7000e-004	5.4000e-004	29.7778
Total		0.7660	6.7463	4.2573	0.0418		0.5292	0.5292		0.5292	0.5292		8,355.9832	8,355.9832	0.1602	0.1532	8,405.6387

6.0 Area Detail

6.1 Mitigation Measures Area

Village South Specific Plan (Proposed) - Los Angeles-South Coast County, Winter

	ROG	NOx	CO	SO2	Fugitive PM10	Exhaust PM10	PM10 Total	Fugitive PM2.5	Exhaust PM2.5	PM2.5 Total	Bio- CO2	NBio- CO2	Total CO2	CH4	N2O	CO2e
Category	lb/day										lb/day					
Mitigated	30.5020	15.0496	88.4430	0.0944		1.5974	1.5974		1.5974	1.5974	0.0000	18,148.5950	18,148.5950	0.4874	0.3300	18,259.1192
Unmitigated	30.5020	15.0496	88.4430	0.0944		1.5974	1.5974		1.5974	1.5974	0.0000	18,148.5950	18,148.5950	0.4874	0.3300	18,259.1192

6.2 Area by SubCategory

Unmitigated

	ROG	NOx	CO	SO2	Fugitive PM10	Exhaust PM10	PM10 Total	Fugitive PM2.5	Exhaust PM2.5	PM2.5 Total	Bio- CO2	NBio- CO2	Total CO2	CH4	N2O	CO2e
SubCategory	lb/day										lb/day					
Architectural Coating	2.2670					0.0000	0.0000		0.0000	0.0000			0.0000			0.0000
Consumer Products	24.1085					0.0000	0.0000		0.0000	0.0000			0.0000			0.0000
Hearth	1.6500	14.1000	6.0000	0.0900		1.1400	1.1400		1.1400	1.1400	0.0000	18,000.0000	18,000.0000	0.3450	0.3300	18,106.9650
Landscaping	2.4766	0.9496	82.4430	4.3600e-003		0.4574	0.4574		0.4574	0.4574		148.5950	148.5950	0.1424		152.1542
Total	30.5020	15.0496	88.4430	0.0944		1.5974	1.5974		1.5974	1.5974	0.0000	18,148.5950	18,148.5950	0.4874	0.3300	18,259.1192

Village South Specific Plan (Proposed) - Los Angeles-South Coast County, Winter

6.2 Area by SubCategory

Mitigated

	ROG	NOx	CO	SO2	Fugitive PM10	Exhaust PM10	PM10 Total	Fugitive PM2.5	Exhaust PM2.5	PM2.5 Total	Bio- CO2	NBio- CO2	Total CO2	CH4	N2O	CO2e
SubCategory	lb/day										lb/day					
Architectural Coating	2.2670					0.0000	0.0000		0.0000	0.0000			0.0000			0.0000
Consumer Products	24.1085					0.0000	0.0000		0.0000	0.0000			0.0000			0.0000
Hearth	1.6500	14.1000	6.0000	0.0900		1.1400	1.1400		1.1400	1.1400	0.0000	18,000.0000	18,000.0000	0.3450	0.3300	18,106.9650
Landscaping	2.4766	0.9496	82.4430	4.3600e-003		0.4574	0.4574		0.4574	0.4574		148.5950	148.5950	0.1424		152.1542
Total	30.5020	15.0496	88.4430	0.0944		1.5974	1.5974		1.5974	1.5974	0.0000	18,148.5950	18,148.5950	0.4874	0.3300	18,259.1192

7.0 Water Detail

7.1 Mitigation Measures Water

8.0 Waste Detail

8.1 Mitigation Measures Waste

9.0 Operational Offroad

Equipment Type	Number	Hours/Day	Days/Year	Horse Power	Load Factor	Fuel Type
----------------	--------	-----------	-----------	-------------	-------------	-----------

10.0 Stationary Equipment

Village South Specific Plan (Proposed) - Los Angeles-South Coast County, Winter

Fire Pumps and Emergency Generators

Equipment Type	Number	Hours/Day	Hours/Year	Horse Power	Load Factor	Fuel Type
----------------	--------	-----------	------------	-------------	-------------	-----------

Boilers

Equipment Type	Number	Heat Input/Day	Heat Input/Year	Boiler Rating	Fuel Type
----------------	--------	----------------	-----------------	---------------	-----------

User Defined Equipment

Equipment Type	Number
----------------	--------

11.0 Vegetation

Village South Specific Plan (Proposed) - Los Angeles-South Coast County, Annual

Village South Specific Plan (Proposed)
Los Angeles-South Coast County, Annual

1.0 Project Characteristics

1.1 Land Usage

Land Uses	Size	Metric	Lot Acreage	Floor Surface Area	Population
General Office Building	45.00	1000sqft	1.03	45,000.00	0
High Turnover (Sit Down Restaurant)	36.00	1000sqft	0.83	36,000.00	0
Hotel	50.00	Room	1.67	72,600.00	0
Quality Restaurant	8.00	1000sqft	0.18	8,000.00	0
Apartments Low Rise	25.00	Dwelling Unit	1.56	25,000.00	72
Apartments Mid Rise	975.00	Dwelling Unit	25.66	975,000.00	2789
Regional Shopping Center	56.00	1000sqft	1.29	56,000.00	0

1.2 Other Project Characteristics

Urbanization	Urban	Wind Speed (m/s)	2.2	Precipitation Freq (Days)	33
Climate Zone	9			Operational Year	2028
Utility Company	Southern California Edison				
CO2 Intensity (lb/MW hr)	702.44	CH4 Intensity (lb/MW hr)	0.029	N2O Intensity (lb/MW hr)	0.006

1.3 User Entered Comments & Non-Default Data

Village South Specific Plan (Proposed) - Los Angeles-South Coast County, Annual

Project Characteristics - Consistent with the DEIR's model.

Land Use - See SWAPE comment regarding residential and retail land uses.

Construction Phase - See SWAPE comment regarding individual construction phase lengths.

Demolition - Consistent with the DEIR's model. See SWAPE comment regarding demolition.

Vehicle Trips - Saturday trips consistent with the DEIR's model. See SWAPE comment regarding weekday and Sunday trips.

Woodstoves - Woodstoves and wood-burning fireplaces consistent with the DEIR's model. See SWAPE comment regarding gas fireplaces.

Energy Use -

Construction Off-road Equipment Mitigation - See SWAPE comment on construction-related mitigation.

Area Mitigation - See SWAPE comment regarding operational mitigation measures.

Water Mitigation - See SWAPE comment regarding operational mitigation measures.

Trips and VMT - Local hire provision

Table Name	Column Name	Default Value	New Value
tblFireplaces	FireplaceWoodMass	1,019.20	0.00
tblFireplaces	FireplaceWoodMass	1,019.20	0.00
tblFireplaces	NumberWood	1.25	0.00
tblFireplaces	NumberWood	48.75	0.00
tblTripsAndVMT	WorkerTripLength	14.70	10.00
tblTripsAndVMT	WorkerTripLength	14.70	10.00
tblTripsAndVMT	WorkerTripLength	14.70	10.00
tblTripsAndVMT	WorkerTripLength	14.70	10.00
tblTripsAndVMT	WorkerTripLength	14.70	10.00
tblTripsAndVMT	WorkerTripLength	14.70	10.00
tblVehicleTrips	ST_TR	7.16	6.17
tblVehicleTrips	ST_TR	6.39	3.87
tblVehicleTrips	ST_TR	2.46	1.39
tblVehicleTrips	ST_TR	158.37	79.82

Village South Specific Plan (Proposed) - Los Angeles-South Coast County, Annual

tblVehicleTrips	ST_TR	8.19	3.75
tblVehicleTrips	ST_TR	94.36	63.99
tblVehicleTrips	ST_TR	49.97	10.74
tblVehicleTrips	SU_TR	6.07	6.16
tblVehicleTrips	SU_TR	5.86	4.18
tblVehicleTrips	SU_TR	1.05	0.69
tblVehicleTrips	SU_TR	131.84	78.27
tblVehicleTrips	SU_TR	5.95	3.20
tblVehicleTrips	SU_TR	72.16	57.65
tblVehicleTrips	SU_TR	25.24	6.39
tblVehicleTrips	WD_TR	6.59	5.83
tblVehicleTrips	WD_TR	6.65	4.13
tblVehicleTrips	WD_TR	11.03	6.41
tblVehicleTrips	WD_TR	127.15	65.80
tblVehicleTrips	WD_TR	8.17	3.84
tblVehicleTrips	WD_TR	89.95	62.64
tblVehicleTrips	WD_TR	42.70	9.43
tblWoodstoves	NumberCatalytic	1.25	0.00
tblWoodstoves	NumberCatalytic	48.75	0.00
tblWoodstoves	NumberNoncatalytic	1.25	0.00
tblWoodstoves	NumberNoncatalytic	48.75	0.00
tblWoodstoves	WoodstoveDayYear	25.00	0.00
tblWoodstoves	WoodstoveDayYear	25.00	0.00
tblWoodstoves	WoodstoveWoodMass	999.60	0.00
tblWoodstoves	WoodstoveWoodMass	999.60	0.00

2.0 Emissions Summary

Village South Specific Plan (Proposed) - Los Angeles-South Coast County, Annual

2.1 Overall Construction

Unmitigated Construction

	ROG	NOx	CO	SO2	Fugitive PM10	Exhaust PM10	PM10 Total	Fugitive PM2.5	Exhaust PM2.5	PM2.5 Total	Bio- CO2	NBio- CO2	Total CO2	CH4	N2O	CO2e
Year	tons/yr										MT/yr					
2021	0.1704	1.8234	1.1577	2.3800e-003	0.4141	0.0817	0.4958	0.1788	0.0754	0.2542	0.0000	210.7654	210.7654	0.0600	0.0000	212.2661
2022	0.5865	4.0240	5.1546	0.0155	0.9509	0.1175	1.0683	0.2518	0.1103	0.3621	0.0000	1,418.6554	1,418.6554	0.1215	0.0000	1,421.6925
2023	0.5190	3.2850	4.7678	0.0147	0.8497	0.0971	0.9468	0.2283	0.0912	0.3195	0.0000	1,342.4412	1,342.4412	0.1115	0.0000	1,345.2291
2024	4.1592	0.1313	0.2557	5.0000e-004	0.0221	6.3900e-003	0.0285	5.8700e-003	5.9700e-003	0.0118	0.0000	44.6355	44.6355	7.8300e-003	0.0000	44.8311
Maximum	4.1592	4.0240	5.1546	0.0155	0.9509	0.1175	1.0683	0.2518	0.1103	0.3621	0.0000	1,418.6554	1,418.6554	0.1215	0.0000	1,421.6925

Village South Specific Plan (Proposed) - Los Angeles-South Coast County, Annual

2.1 Overall Construction

Mitigated Construction

	ROG	NOx	CO	SO2	Fugitive PM10	Exhaust PM10	PM10 Total	Fugitive PM2.5	Exhaust PM2.5	PM2.5 Total	Bio- CO2	NBio- CO2	Total CO2	CH4	N2O	CO2e
Year	tons/yr										MT/yr					
2021	0.1704	1.8234	1.1577	2.3800e-003	0.4141	0.0817	0.4958	0.1788	0.0754	0.2542	0.0000	210.7651	210.7651	0.0600	0.0000	212.2658
2022	0.5865	4.0240	5.1546	0.0155	0.9509	0.1175	1.0683	0.2518	0.1103	0.3621	0.0000	1,418.6550	1,418.6550	0.1215	0.0000	1,421.6921
2023	0.5190	3.2850	4.7678	0.0147	0.8497	0.0971	0.9468	0.2283	0.0912	0.3195	0.0000	1,342.4409	1,342.4409	0.1115	0.0000	1,345.2287
2024	4.1592	0.1313	0.2557	5.0000e-004	0.0221	6.3900e-003	0.0285	5.8700e-003	5.9700e-003	0.0118	0.0000	44.6354	44.6354	7.8300e-003	0.0000	44.8311
Maximum	4.1592	4.0240	5.1546	0.0155	0.9509	0.1175	1.0683	0.2518	0.1103	0.3621	0.0000	1,418.6550	1,418.6550	0.1215	0.0000	1,421.6921

	ROG	NOx	CO	SO2	Fugitive PM10	Exhaust PM10	PM10 Total	Fugitive PM2.5	Exhaust PM2.5	PM2.5 Total	Bio- CO2	NBio- CO2	Total CO2	CH4	N2O	CO2e
Percent Reduction	0.00	0.00	0.00	0.00	0.00	0.00	0.00	0.00	0.00	0.00	0.00	0.00	0.00	0.00	0.00	0.00

Quarter	Start Date	End Date	Maximum Unmitigated ROG + NOX (tons/quarter)	Maximum Mitigated ROG + NOX (tons/quarter)
1	9-1-2021	11-30-2021	1.4091	1.4091
2	12-1-2021	2-28-2022	1.3329	1.3329
3	3-1-2022	5-31-2022	1.1499	1.1499
4	6-1-2022	8-31-2022	1.1457	1.1457
5	9-1-2022	11-30-2022	1.1415	1.1415
6	12-1-2022	2-28-2023	1.0278	1.0278
7	3-1-2023	5-31-2023	0.9868	0.9868
8	6-1-2023	8-31-2023	0.9831	0.9831

Village South Specific Plan (Proposed) - Los Angeles-South Coast County, Annual

9	9-1-2023	11-30-2023	0.9798	0.9798
10	12-1-2023	2-29-2024	2.8757	2.8757
11	3-1-2024	5-31-2024	1.6188	1.6188
		Highest	2.8757	2.8757

2.2 Overall Operational
Unmitigated Operational

	ROG	NOx	CO	SO2	Fugitive PM10	Exhaust PM10	PM10 Total	Fugitive PM2.5	Exhaust PM2.5	PM2.5 Total	Bio- CO2	NBio- CO2	Total CO2	CH4	N2O	CO2e
Category	tons/yr										MT/yr					
Area	5.1437	0.2950	10.3804	1.6700e-003		0.0714	0.0714		0.0714	0.0714	0.0000	220.9670	220.9670	0.0201	3.7400e-003	222.5835
Energy	0.1398	1.2312	0.7770	7.6200e-003		0.0966	0.0966		0.0966	0.0966	0.0000	3,896.0732	3,896.0732	0.1303	0.0468	3,913.2833
Mobile	1.5857	7.9962	19.1834	0.0821	7.7979	0.0580	7.8559	2.0895	0.0539	2.1434	0.0000	7,620.4986	7,620.4986	0.3407	0.0000	7,629.0162
Waste						0.0000	0.0000		0.0000	0.0000	207.8079	0.0000	207.8079	12.2811	0.0000	514.8354
Water						0.0000	0.0000		0.0000	0.0000	29.1632	556.6420	585.8052	3.0183	0.0755	683.7567
Total	6.8692	9.5223	30.3407	0.0914	7.7979	0.2260	8.0240	2.0895	0.2219	2.3114	236.9712	12,294.1807	12,531.1519	15.7904	0.1260	12,963.4751

Village South Specific Plan (Proposed) - Los Angeles-South Coast County, Annual

2.2 Overall Operational

Mitigated Operational

	ROG	NOx	CO	SO2	Fugitive PM10	Exhaust PM10	PM10 Total	Fugitive PM2.5	Exhaust PM2.5	PM2.5 Total	Bio- CO2	NBio- CO2	Total CO2	CH4	N2O	CO2e
Category	tons/yr										MT/yr					
Area	5.1437	0.2950	10.3804	1.6700e-003		0.0714	0.0714		0.0714	0.0714	0.0000	220.9670	220.9670	0.0201	3.7400e-003	222.5835
Energy	0.1398	1.2312	0.7770	7.6200e-003		0.0966	0.0966		0.0966	0.0966	0.0000	3,896.0732	3,896.0732	0.1303	0.0468	3,913.2833
Mobile	1.5857	7.9962	19.1834	0.0821	7.7979	0.0580	7.8559	2.0895	0.0539	2.1434	0.0000	7,620.4986	7,620.4986	0.3407	0.0000	7,629.0162
Waste						0.0000	0.0000		0.0000	0.0000	207.8079	0.0000	207.8079	12.2811	0.0000	514.8354
Water						0.0000	0.0000		0.0000	0.0000	29.1632	556.6420	585.8052	3.0183	0.0755	683.7567
Total	6.8692	9.5223	30.3407	0.0914	7.7979	0.2260	8.0240	2.0895	0.2219	2.3114	236.9712	12,294.1807	12,531.1519	15.7904	0.1260	12,963.4751

	ROG	NOx	CO	SO2	Fugitive PM10	Exhaust PM10	PM10 Total	Fugitive PM2.5	Exhaust PM2.5	PM2.5 Total	Bio- CO2	NBio- CO2	Total CO2	CH4	N2O	CO2e
Percent Reduction	0.00	0.00	0.00	0.00	0.00	0.00	0.00	0.00	0.00	0.00	0.00	0.00	0.00	0.00	0.00	0.00

3.0 Construction Detail

Construction Phase

Village South Specific Plan (Proposed) - Los Angeles-South Coast County, Annual

Phase Number	Phase Name	Phase Type	Start Date	End Date	Num Days Week	Num Days	Phase Description
1	Demolition	Demolition	9/1/2021	10/12/2021	5	30	
2	Site Preparation	Site Preparation	10/13/2021	11/9/2021	5	20	
3	Grading	Grading	11/10/2021	1/11/2022	5	45	
4	Building Construction	Building Construction	1/12/2022	12/12/2023	5	500	
5	Paving	Paving	12/13/2023	1/30/2024	5	35	
6	Architectural Coating	Architectural Coating	1/31/2024	3/19/2024	5	35	

Acres of Grading (Site Preparation Phase): 0

Acres of Grading (Grading Phase): 112.5

Acres of Paving: 0

Residential Indoor: 2,025,000; Residential Outdoor: 675,000; Non-Residential Indoor: 326,400; Non-Residential Outdoor: 108,800; Striped Parking Area: 0 (Architectural Coating – sqft)

OffRoad Equipment

Village South Specific Plan (Proposed) - Los Angeles-South Coast County, Annual

Phase Name	Offroad Equipment Type	Amount	Usage Hours	Horse Power	Load Factor
Demolition	Concrete/Industrial Saws	1	8.00	81	0.73
Demolition	Excavators	3	8.00	158	0.38
Demolition	Rubber Tired Dozers	2	8.00	247	0.40
Site Preparation	Rubber Tired Dozers	3	8.00	247	0.40
Site Preparation	Tractors/Loaders/Backhoes	4	8.00	97	0.37
Grading	Excavators	2	8.00	158	0.38
Grading	Graders	1	8.00	187	0.41
Grading	Rubber Tired Dozers	1	8.00	247	0.40
Grading	Scrapers	2	8.00	367	0.48
Grading	Tractors/Loaders/Backhoes	2	8.00	97	0.37
Building Construction	Cranes	1	7.00	231	0.29
Building Construction	Forklifts	3	8.00	89	0.20
Building Construction	Generator Sets	1	8.00	84	0.74
Building Construction	Tractors/Loaders/Backhoes	3	7.00	97	0.37
Building Construction	Welders	1	8.00	46	0.45
Paving	Pavers	2	8.00	130	0.42
Paving	Paving Equipment	2	8.00	132	0.36
Paving	Rollers	2	8.00	80	0.38
Architectural Coating	Air Compressors	1	6.00	78	0.48

Trips and VMT

Village South Specific Plan (Proposed) - Los Angeles-South Coast County, Annual

Phase Name	Offroad Equipment Count	Worker Trip Number	Vendor Trip Number	Hauling Trip Number	Worker Trip Length	Vendor Trip Length	Hauling Trip Length	Worker Vehicle Class	Vendor Vehicle Class	Hauling Vehicle Class
Demolition	6	15.00	0.00	458.00	10.00	6.90	20.00	LD_Mix	HDT_Mix	HHDT
Site Preparation	7	18.00	0.00	0.00	10.00	6.90	20.00	LD_Mix	HDT_Mix	HHDT
Grading	8	20.00	0.00	0.00	10.00	6.90	20.00	LD_Mix	HDT_Mix	HHDT
Building Construction	9	801.00	143.00	0.00	10.00	6.90	20.00	LD_Mix	HDT_Mix	HHDT
Paving	6	15.00	0.00	0.00	10.00	6.90	20.00	LD_Mix	HDT_Mix	HHDT
Architectural Coating	1	160.00	0.00	0.00	10.00	6.90	20.00	LD_Mix	HDT_Mix	HHDT

3.1 Mitigation Measures Construction

3.2 Demolition - 2021

Unmitigated Construction On-Site

	ROG	NOx	CO	SO2	Fugitive PM10	Exhaust PM10	PM10 Total	Fugitive PM2.5	Exhaust PM2.5	PM2.5 Total	Bio- CO2	NBio- CO2	Total CO2	CH4	N2O	CO2e
Category	tons/yr										MT/yr					
Fugitive Dust					0.0496	0.0000	0.0496	7.5100e-003	0.0000	7.5100e-003	0.0000	0.0000	0.0000	0.0000	0.0000	0.0000
Off-Road	0.0475	0.4716	0.3235	5.8000e-004		0.0233	0.0233		0.0216	0.0216	0.0000	51.0012	51.0012	0.0144	0.0000	51.3601
Total	0.0475	0.4716	0.3235	5.8000e-004	0.0496	0.0233	0.0729	7.5100e-003	0.0216	0.0291	0.0000	51.0012	51.0012	0.0144	0.0000	51.3601

Village South Specific Plan (Proposed) - Los Angeles-South Coast County, Annual

3.2 Demolition - 2021

Unmitigated Construction Off-Site

	ROG	NOx	CO	SO2	Fugitive PM10	Exhaust PM10	PM10 Total	Fugitive PM2.5	Exhaust PM2.5	PM2.5 Total	Bio- CO2	NBio- CO2	Total CO2	CH4	N2O	CO2e
Category	tons/yr										MT/yr					
Hauling	1.9300e-003	0.0634	0.0148	1.8000e-004	3.9400e-003	1.9000e-004	4.1300e-003	1.0800e-003	1.8000e-004	1.2600e-003	0.0000	17.4566	17.4566	1.2100e-003	0.0000	17.4869
Vendor	0.0000	0.0000	0.0000	0.0000	0.0000	0.0000	0.0000	0.0000	0.0000	0.0000	0.0000	0.0000	0.0000	0.0000	0.0000	0.0000
Worker	7.2000e-004	5.3000e-004	6.0900e-003	2.0000e-005	1.6800e-003	1.0000e-005	1.6900e-003	4.5000e-004	1.0000e-005	4.6000e-004	0.0000	1.5281	1.5281	5.0000e-005	0.0000	1.5293
Total	2.6500e-003	0.0639	0.0209	2.0000e-004	5.6200e-003	2.0000e-004	5.8200e-003	1.5300e-003	1.9000e-004	1.7200e-003	0.0000	18.9847	18.9847	1.2600e-003	0.0000	19.0161

Mitigated Construction On-Site

	ROG	NOx	CO	SO2	Fugitive PM10	Exhaust PM10	PM10 Total	Fugitive PM2.5	Exhaust PM2.5	PM2.5 Total	Bio- CO2	NBio- CO2	Total CO2	CH4	N2O	CO2e
Category	tons/yr										MT/yr					
Fugitive Dust					0.0496	0.0000	0.0496	7.5100e-003	0.0000	7.5100e-003	0.0000	0.0000	0.0000	0.0000	0.0000	0.0000
Off-Road	0.0475	0.4716	0.3235	5.8000e-004		0.0233	0.0233		0.0216	0.0216	0.0000	51.0011	51.0011	0.0144	0.0000	51.3600
Total	0.0475	0.4716	0.3235	5.8000e-004	0.0496	0.0233	0.0729	7.5100e-003	0.0216	0.0291	0.0000	51.0011	51.0011	0.0144	0.0000	51.3600

Village South Specific Plan (Proposed) - Los Angeles-South Coast County, Annual

3.2 Demolition - 2021

Mitigated Construction Off-Site

	ROG	NOx	CO	SO2	Fugitive PM10	Exhaust PM10	PM10 Total	Fugitive PM2.5	Exhaust PM2.5	PM2.5 Total	Bio- CO2	NBio- CO2	Total CO2	CH4	N2O	CO2e
Category	tons/yr										MT/yr					
Hauling	1.9300e-003	0.0634	0.0148	1.8000e-004	3.9400e-003	1.9000e-004	4.1300e-003	1.0800e-003	1.8000e-004	1.2600e-003	0.0000	17.4566	17.4566	1.2100e-003	0.0000	17.4869
Vendor	0.0000	0.0000	0.0000	0.0000	0.0000	0.0000	0.0000	0.0000	0.0000	0.0000	0.0000	0.0000	0.0000	0.0000	0.0000	0.0000
Worker	7.2000e-004	5.3000e-004	6.0900e-003	2.0000e-005	1.6800e-003	1.0000e-005	1.6900e-003	4.5000e-004	1.0000e-005	4.6000e-004	0.0000	1.5281	1.5281	5.0000e-005	0.0000	1.5293
Total	2.6500e-003	0.0639	0.0209	2.0000e-004	5.6200e-003	2.0000e-004	5.8200e-003	1.5300e-003	1.9000e-004	1.7200e-003	0.0000	18.9847	18.9847	1.2600e-003	0.0000	19.0161

3.3 Site Preparation - 2021

Unmitigated Construction On-Site

	ROG	NOx	CO	SO2	Fugitive PM10	Exhaust PM10	PM10 Total	Fugitive PM2.5	Exhaust PM2.5	PM2.5 Total	Bio- CO2	NBio- CO2	Total CO2	CH4	N2O	CO2e
Category	tons/yr										MT/yr					
Fugitive Dust					0.1807	0.0000	0.1807	0.0993	0.0000	0.0993	0.0000	0.0000	0.0000	0.0000	0.0000	0.0000
Off-Road	0.0389	0.4050	0.2115	3.8000e-004		0.0204	0.0204		0.0188	0.0188	0.0000	33.4357	33.4357	0.0108	0.0000	33.7061
Total	0.0389	0.4050	0.2115	3.8000e-004	0.1807	0.0204	0.2011	0.0993	0.0188	0.1181	0.0000	33.4357	33.4357	0.0108	0.0000	33.7061

Village South Specific Plan (Proposed) - Los Angeles-South Coast County, Annual

3.3 Site Preparation - 2021

Unmitigated Construction Off-Site

	ROG	NOx	CO	SO2	Fugitive PM10	Exhaust PM10	PM10 Total	Fugitive PM2.5	Exhaust PM2.5	PM2.5 Total	Bio- CO2	NBio- CO2	Total CO2	CH4	N2O	CO2e
Category	tons/yr										MT/yr					
Hauling	0.0000	0.0000	0.0000	0.0000	0.0000	0.0000	0.0000	0.0000	0.0000	0.0000	0.0000	0.0000	0.0000	0.0000	0.0000	0.0000
Vendor	0.0000	0.0000	0.0000	0.0000	0.0000	0.0000	0.0000	0.0000	0.0000	0.0000	0.0000	0.0000	0.0000	0.0000	0.0000	0.0000
Worker	5.8000e-004	4.3000e-004	4.8700e-003	1.0000e-005	1.3400e-003	1.0000e-005	1.3500e-003	3.6000e-004	1.0000e-005	3.7000e-004	0.0000	1.2225	1.2225	4.0000e-005	0.0000	1.2234
Total	5.8000e-004	4.3000e-004	4.8700e-003	1.0000e-005	1.3400e-003	1.0000e-005	1.3500e-003	3.6000e-004	1.0000e-005	3.7000e-004	0.0000	1.2225	1.2225	4.0000e-005	0.0000	1.2234

Mitigated Construction On-Site

	ROG	NOx	CO	SO2	Fugitive PM10	Exhaust PM10	PM10 Total	Fugitive PM2.5	Exhaust PM2.5	PM2.5 Total	Bio- CO2	NBio- CO2	Total CO2	CH4	N2O	CO2e
Category	tons/yr										MT/yr					
Fugitive Dust					0.1807	0.0000	0.1807	0.0993	0.0000	0.0993	0.0000	0.0000	0.0000	0.0000	0.0000	0.0000
Off-Road	0.0389	0.4050	0.2115	3.8000e-004		0.0204	0.0204		0.0188	0.0188	0.0000	33.4357	33.4357	0.0108	0.0000	33.7060
Total	0.0389	0.4050	0.2115	3.8000e-004	0.1807	0.0204	0.2011	0.0993	0.0188	0.1181	0.0000	33.4357	33.4357	0.0108	0.0000	33.7060

Village South Specific Plan (Proposed) - Los Angeles-South Coast County, Annual

3.3 Site Preparation - 2021

Mitigated Construction Off-Site

	ROG	NOx	CO	SO2	Fugitive PM10	Exhaust PM10	PM10 Total	Fugitive PM2.5	Exhaust PM2.5	PM2.5 Total	Bio- CO2	NBio- CO2	Total CO2	CH4	N2O	CO2e
Category	tons/yr										MT/yr					
Hauling	0.0000	0.0000	0.0000	0.0000	0.0000	0.0000	0.0000	0.0000	0.0000	0.0000	0.0000	0.0000	0.0000	0.0000	0.0000	0.0000
Vendor	0.0000	0.0000	0.0000	0.0000	0.0000	0.0000	0.0000	0.0000	0.0000	0.0000	0.0000	0.0000	0.0000	0.0000	0.0000	0.0000
Worker	5.8000e-004	4.3000e-004	4.8700e-003	1.0000e-005	1.3400e-003	1.0000e-005	1.3500e-003	3.6000e-004	1.0000e-005	3.7000e-004	0.0000	1.2225	1.2225	4.0000e-005	0.0000	1.2234
Total	5.8000e-004	4.3000e-004	4.8700e-003	1.0000e-005	1.3400e-003	1.0000e-005	1.3500e-003	3.6000e-004	1.0000e-005	3.7000e-004	0.0000	1.2225	1.2225	4.0000e-005	0.0000	1.2234

3.4 Grading - 2021

Unmitigated Construction On-Site

	ROG	NOx	CO	SO2	Fugitive PM10	Exhaust PM10	PM10 Total	Fugitive PM2.5	Exhaust PM2.5	PM2.5 Total	Bio- CO2	NBio- CO2	Total CO2	CH4	N2O	CO2e
Category	tons/yr										MT/yr					
Fugitive Dust					0.1741	0.0000	0.1741	0.0693	0.0000	0.0693	0.0000	0.0000	0.0000	0.0000	0.0000	0.0000
Off-Road	0.0796	0.8816	0.5867	1.1800e-003		0.0377	0.0377		0.0347	0.0347	0.0000	103.5405	103.5405	0.0335	0.0000	104.3776
Total	0.0796	0.8816	0.5867	1.1800e-003	0.1741	0.0377	0.2118	0.0693	0.0347	0.1040	0.0000	103.5405	103.5405	0.0335	0.0000	104.3776

Village South Specific Plan (Proposed) - Los Angeles-South Coast County, Annual

3.4 Grading - 2021

Unmitigated Construction Off-Site

	ROG	NOx	CO	SO2	Fugitive PM10	Exhaust PM10	PM10 Total	Fugitive PM2.5	Exhaust PM2.5	PM2.5 Total	Bio- CO2	NBio- CO2	Total CO2	CH4	N2O	CO2e
Category	tons/yr										MT/yr					
Hauling	0.0000	0.0000	0.0000	0.0000	0.0000	0.0000	0.0000	0.0000	0.0000	0.0000	0.0000	0.0000	0.0000	0.0000	0.0000	0.0000
Vendor	0.0000	0.0000	0.0000	0.0000	0.0000	0.0000	0.0000	0.0000	0.0000	0.0000	0.0000	0.0000	0.0000	0.0000	0.0000	0.0000
Worker	1.2200e-003	9.0000e-004	0.0103	3.0000e-005	2.8300e-003	2.0000e-005	2.8600e-003	7.5000e-004	2.0000e-005	7.8000e-004	0.0000	2.5808	2.5808	8.0000e-005	0.0000	2.5828
Total	1.2200e-003	9.0000e-004	0.0103	3.0000e-005	2.8300e-003	2.0000e-005	2.8600e-003	7.5000e-004	2.0000e-005	7.8000e-004	0.0000	2.5808	2.5808	8.0000e-005	0.0000	2.5828

Mitigated Construction On-Site

	ROG	NOx	CO	SO2	Fugitive PM10	Exhaust PM10	PM10 Total	Fugitive PM2.5	Exhaust PM2.5	PM2.5 Total	Bio- CO2	NBio- CO2	Total CO2	CH4	N2O	CO2e
Category	tons/yr										MT/yr					
Fugitive Dust					0.1741	0.0000	0.1741	0.0693	0.0000	0.0693	0.0000	0.0000	0.0000	0.0000	0.0000	0.0000
Off-Road	0.0796	0.8816	0.5867	1.1800e-003		0.0377	0.0377		0.0347	0.0347	0.0000	103.5403	103.5403	0.0335	0.0000	104.3775
Total	0.0796	0.8816	0.5867	1.1800e-003	0.1741	0.0377	0.2118	0.0693	0.0347	0.1040	0.0000	103.5403	103.5403	0.0335	0.0000	104.3775

Village South Specific Plan (Proposed) - Los Angeles-South Coast County, Annual

3.4 Grading - 2021

Mitigated Construction Off-Site

	ROG	NOx	CO	SO2	Fugitive PM10	Exhaust PM10	PM10 Total	Fugitive PM2.5	Exhaust PM2.5	PM2.5 Total	Bio- CO2	NBio- CO2	Total CO2	CH4	N2O	CO2e
Category	tons/yr										MT/yr					
Hauling	0.0000	0.0000	0.0000	0.0000	0.0000	0.0000	0.0000	0.0000	0.0000	0.0000	0.0000	0.0000	0.0000	0.0000	0.0000	0.0000
Vendor	0.0000	0.0000	0.0000	0.0000	0.0000	0.0000	0.0000	0.0000	0.0000	0.0000	0.0000	0.0000	0.0000	0.0000	0.0000	0.0000
Worker	1.2200e-003	9.0000e-004	0.0103	3.0000e-005	2.8300e-003	2.0000e-005	2.8600e-003	7.5000e-004	2.0000e-005	7.8000e-004	0.0000	2.5808	2.5808	8.0000e-005	0.0000	2.5828
Total	1.2200e-003	9.0000e-004	0.0103	3.0000e-005	2.8300e-003	2.0000e-005	2.8600e-003	7.5000e-004	2.0000e-005	7.8000e-004	0.0000	2.5808	2.5808	8.0000e-005	0.0000	2.5828

3.4 Grading - 2022

Unmitigated Construction On-Site

	ROG	NOx	CO	SO2	Fugitive PM10	Exhaust PM10	PM10 Total	Fugitive PM2.5	Exhaust PM2.5	PM2.5 Total	Bio- CO2	NBio- CO2	Total CO2	CH4	N2O	CO2e
Category	tons/yr										MT/yr					
Fugitive Dust					0.0807	0.0000	0.0807	0.0180	0.0000	0.0180	0.0000	0.0000	0.0000	0.0000	0.0000	0.0000
Off-Road	0.0127	0.1360	0.1017	2.2000e-004		5.7200e-003	5.7200e-003		5.2600e-003	5.2600e-003	0.0000	19.0871	19.0871	6.1700e-003	0.0000	19.2414
Total	0.0127	0.1360	0.1017	2.2000e-004	0.0807	5.7200e-003	0.0865	0.0180	5.2600e-003	0.0233	0.0000	19.0871	19.0871	6.1700e-003	0.0000	19.2414

Village South Specific Plan (Proposed) - Los Angeles-South Coast County, Annual

3.4 Grading - 2022

Unmitigated Construction Off-Site

	ROG	NOx	CO	SO2	Fugitive PM10	Exhaust PM10	PM10 Total	Fugitive PM2.5	Exhaust PM2.5	PM2.5 Total	Bio- CO2	NBio- CO2	Total CO2	CH4	N2O	CO2e
Category	tons/yr										MT/yr					
Hauling	0.0000	0.0000	0.0000	0.0000	0.0000	0.0000	0.0000	0.0000	0.0000	0.0000	0.0000	0.0000	0.0000	0.0000	0.0000	0.0000
Vendor	0.0000	0.0000	0.0000	0.0000	0.0000	0.0000	0.0000	0.0000	0.0000	0.0000	0.0000	0.0000	0.0000	0.0000	0.0000	0.0000
Worker	2.1000e-004	1.5000e-004	1.7400e-003	1.0000e-005	5.2000e-004	0.0000	5.3000e-004	1.4000e-004	0.0000	1.4000e-004	0.0000	0.4587	0.4587	1.0000e-005	0.0000	0.4590
Total	2.1000e-004	1.5000e-004	1.7400e-003	1.0000e-005	5.2000e-004	0.0000	5.3000e-004	1.4000e-004	0.0000	1.4000e-004	0.0000	0.4587	0.4587	1.0000e-005	0.0000	0.4590

Mitigated Construction On-Site

	ROG	NOx	CO	SO2	Fugitive PM10	Exhaust PM10	PM10 Total	Fugitive PM2.5	Exhaust PM2.5	PM2.5 Total	Bio- CO2	NBio- CO2	Total CO2	CH4	N2O	CO2e
Category	tons/yr										MT/yr					
Fugitive Dust					0.0807	0.0000	0.0807	0.0180	0.0000	0.0180	0.0000	0.0000	0.0000	0.0000	0.0000	0.0000
Off-Road	0.0127	0.1360	0.1017	2.2000e-004		5.7200e-003	5.7200e-003		5.2600e-003	5.2600e-003	0.0000	19.0871	19.0871	6.1700e-003	0.0000	19.2414
Total	0.0127	0.1360	0.1017	2.2000e-004	0.0807	5.7200e-003	0.0865	0.0180	5.2600e-003	0.0233	0.0000	19.0871	19.0871	6.1700e-003	0.0000	19.2414

Village South Specific Plan (Proposed) - Los Angeles-South Coast County, Annual

3.4 Grading - 2022

Mitigated Construction Off-Site

	ROG	NOx	CO	SO2	Fugitive PM10	Exhaust PM10	PM10 Total	Fugitive PM2.5	Exhaust PM2.5	PM2.5 Total	Bio- CO2	NBio- CO2	Total CO2	CH4	N2O	CO2e
Category	tons/yr										MT/yr					
Hauling	0.0000	0.0000	0.0000	0.0000	0.0000	0.0000	0.0000	0.0000	0.0000	0.0000	0.0000	0.0000	0.0000	0.0000	0.0000	0.0000
Vendor	0.0000	0.0000	0.0000	0.0000	0.0000	0.0000	0.0000	0.0000	0.0000	0.0000	0.0000	0.0000	0.0000	0.0000	0.0000	0.0000
Worker	2.1000e-004	1.5000e-004	1.7400e-003	1.0000e-005	5.2000e-004	0.0000	5.3000e-004	1.4000e-004	0.0000	1.4000e-004	0.0000	0.4587	0.4587	1.0000e-005	0.0000	0.4590
Total	2.1000e-004	1.5000e-004	1.7400e-003	1.0000e-005	5.2000e-004	0.0000	5.3000e-004	1.4000e-004	0.0000	1.4000e-004	0.0000	0.4587	0.4587	1.0000e-005	0.0000	0.4590

3.5 Building Construction - 2022

Unmitigated Construction On-Site

	ROG	NOx	CO	SO2	Fugitive PM10	Exhaust PM10	PM10 Total	Fugitive PM2.5	Exhaust PM2.5	PM2.5 Total	Bio- CO2	NBio- CO2	Total CO2	CH4	N2O	CO2e
Category	tons/yr										MT/yr					
Off-Road	0.2158	1.9754	2.0700	3.4100e-003		0.1023	0.1023		0.0963	0.0963	0.0000	293.1324	293.1324	0.0702	0.0000	294.8881
Total	0.2158	1.9754	2.0700	3.4100e-003		0.1023	0.1023		0.0963	0.0963	0.0000	293.1324	293.1324	0.0702	0.0000	294.8881

Village South Specific Plan (Proposed) - Los Angeles-South Coast County, Annual

3.5 Building Construction - 2022

Unmitigated Construction Off-Site

	ROG	NOx	CO	SO2	Fugitive PM10	Exhaust PM10	PM10 Total	Fugitive PM2.5	Exhaust PM2.5	PM2.5 Total	Bio- CO2	NBio- CO2	Total CO2	CH4	N2O	CO2e
Category	tons/yr										MT/yr					
Hauling	0.0000	0.0000	0.0000	0.0000	0.0000	0.0000	0.0000	0.0000	0.0000	0.0000	0.0000	0.0000	0.0000	0.0000	0.0000	0.0000
Vendor	0.0527	1.6961	0.4580	4.5500e-003	0.1140	3.1800e-003	0.1171	0.0329	3.0400e-003	0.0359	0.0000	441.9835	441.9835	0.0264	0.0000	442.6435
Worker	0.3051	0.2164	2.5233	7.3500e-003	0.7557	6.2300e-003	0.7619	0.2007	5.7400e-003	0.2065	0.0000	663.9936	663.9936	0.0187	0.0000	664.4604
Total	0.3578	1.9125	2.9812	0.0119	0.8696	9.4100e-003	0.8790	0.2336	8.7800e-003	0.2424	0.0000	1,105.9771	1,105.9771	0.0451	0.0000	1,107.1039

Mitigated Construction On-Site

	ROG	NOx	CO	SO2	Fugitive PM10	Exhaust PM10	PM10 Total	Fugitive PM2.5	Exhaust PM2.5	PM2.5 Total	Bio- CO2	NBio- CO2	Total CO2	CH4	N2O	CO2e
Category	tons/yr										MT/yr					
Off-Road	0.2158	1.9754	2.0700	3.4100e-003		0.1023	0.1023		0.0963	0.0963	0.0000	293.1321	293.1321	0.0702	0.0000	294.8877
Total	0.2158	1.9754	2.0700	3.4100e-003		0.1023	0.1023		0.0963	0.0963	0.0000	293.1321	293.1321	0.0702	0.0000	294.8877

Village South Specific Plan (Proposed) - Los Angeles-South Coast County, Annual

3.5 Building Construction - 2022

Mitigated Construction Off-Site

	ROG	NOx	CO	SO2	Fugitive PM10	Exhaust PM10	PM10 Total	Fugitive PM2.5	Exhaust PM2.5	PM2.5 Total	Bio- CO2	NBio- CO2	Total CO2	CH4	N2O	CO2e
Category	tons/yr										MT/yr					
Hauling	0.0000	0.0000	0.0000	0.0000	0.0000	0.0000	0.0000	0.0000	0.0000	0.0000	0.0000	0.0000	0.0000	0.0000	0.0000	0.0000
Vendor	0.0527	1.6961	0.4580	4.5500e-003	0.1140	3.1800e-003	0.1171	0.0329	3.0400e-003	0.0359	0.0000	441.9835	441.9835	0.0264	0.0000	442.6435
Worker	0.3051	0.2164	2.5233	7.3500e-003	0.7557	6.2300e-003	0.7619	0.2007	5.7400e-003	0.2065	0.0000	663.9936	663.9936	0.0187	0.0000	664.4604
Total	0.3578	1.9125	2.9812	0.0119	0.8696	9.4100e-003	0.8790	0.2336	8.7800e-003	0.2424	0.0000	1,105.9771	1,105.9771	0.0451	0.0000	1,107.1039

3.5 Building Construction - 2023

Unmitigated Construction On-Site

	ROG	NOx	CO	SO2	Fugitive PM10	Exhaust PM10	PM10 Total	Fugitive PM2.5	Exhaust PM2.5	PM2.5 Total	Bio- CO2	NBio- CO2	Total CO2	CH4	N2O	CO2e
Category	tons/yr										MT/yr					
Off-Road	0.1942	1.7765	2.0061	3.3300e-003		0.0864	0.0864		0.0813	0.0813	0.0000	286.2789	286.2789	0.0681	0.0000	287.9814
Total	0.1942	1.7765	2.0061	3.3300e-003		0.0864	0.0864		0.0813	0.0813	0.0000	286.2789	286.2789	0.0681	0.0000	287.9814

Village South Specific Plan (Proposed) - Los Angeles-South Coast County, Annual

3.5 Building Construction - 2023

Unmitigated Construction Off-Site

	ROG	NOx	CO	SO2	Fugitive PM10	Exhaust PM10	PM10 Total	Fugitive PM2.5	Exhaust PM2.5	PM2.5 Total	Bio- CO2	NBio- CO2	Total CO2	CH4	N2O	CO2e
Category	tons/yr										MT/yr					
Hauling	0.0000	0.0000	0.0000	0.0000	0.0000	0.0000	0.0000	0.0000	0.0000	0.0000	0.0000	0.0000	0.0000	0.0000	0.0000	0.0000
Vendor	0.0382	1.2511	0.4011	4.3000e-003	0.1113	1.4600e-003	0.1127	0.0321	1.4000e-003	0.0335	0.0000	417.9930	417.9930	0.0228	0.0000	418.5624
Worker	0.2795	0.1910	2.2635	6.9100e-003	0.7377	5.9100e-003	0.7436	0.1960	5.4500e-003	0.2014	0.0000	624.5363	624.5363	0.0164	0.0000	624.9466
Total	0.3177	1.4420	2.6646	0.0112	0.8490	7.3700e-003	0.8564	0.2281	6.8500e-003	0.2349	0.0000	1,042.5294	1,042.5294	0.0392	0.0000	1,043.5090

Mitigated Construction On-Site

	ROG	NOx	CO	SO2	Fugitive PM10	Exhaust PM10	PM10 Total	Fugitive PM2.5	Exhaust PM2.5	PM2.5 Total	Bio- CO2	NBio- CO2	Total CO2	CH4	N2O	CO2e
Category	tons/yr										MT/yr					
Off-Road	0.1942	1.7765	2.0061	3.3300e-003		0.0864	0.0864		0.0813	0.0813	0.0000	286.2785	286.2785	0.0681	0.0000	287.9811
Total	0.1942	1.7765	2.0061	3.3300e-003		0.0864	0.0864		0.0813	0.0813	0.0000	286.2785	286.2785	0.0681	0.0000	287.9811

Village South Specific Plan (Proposed) - Los Angeles-South Coast County, Annual

3.5 Building Construction - 2023

Mitigated Construction Off-Site

	ROG	NOx	CO	SO2	Fugitive PM10	Exhaust PM10	PM10 Total	Fugitive PM2.5	Exhaust PM2.5	PM2.5 Total	Bio- CO2	NBio- CO2	Total CO2	CH4	N2O	CO2e
Category	tons/yr										MT/yr					
Hauling	0.0000	0.0000	0.0000	0.0000	0.0000	0.0000	0.0000	0.0000	0.0000	0.0000	0.0000	0.0000	0.0000	0.0000	0.0000	0.0000
Vendor	0.0382	1.2511	0.4011	4.3000e-003	0.1113	1.4600e-003	0.1127	0.0321	1.4000e-003	0.0335	0.0000	417.9930	417.9930	0.0228	0.0000	418.5624
Worker	0.2795	0.1910	2.2635	6.9100e-003	0.7377	5.9100e-003	0.7436	0.1960	5.4500e-003	0.2014	0.0000	624.5363	624.5363	0.0164	0.0000	624.9466
Total	0.3177	1.4420	2.6646	0.0112	0.8490	7.3700e-003	0.8564	0.2281	6.8500e-003	0.2349	0.0000	1,042.5294	1,042.5294	0.0392	0.0000	1,043.5090

3.6 Paving - 2023

Unmitigated Construction On-Site

	ROG	NOx	CO	SO2	Fugitive PM10	Exhaust PM10	PM10 Total	Fugitive PM2.5	Exhaust PM2.5	PM2.5 Total	Bio- CO2	NBio- CO2	Total CO2	CH4	N2O	CO2e
Category	tons/yr										MT/yr					
Off-Road	6.7100e-003	0.0663	0.0948	1.5000e-004		3.3200e-003	3.3200e-003		3.0500e-003	3.0500e-003	0.0000	13.0175	13.0175	4.2100e-003	0.0000	13.1227
Paving	0.0000					0.0000	0.0000		0.0000	0.0000	0.0000	0.0000	0.0000	0.0000	0.0000	0.0000
Total	6.7100e-003	0.0663	0.0948	1.5000e-004		3.3200e-003	3.3200e-003		3.0500e-003	3.0500e-003	0.0000	13.0175	13.0175	4.2100e-003	0.0000	13.1227

Village South Specific Plan (Proposed) - Los Angeles-South Coast County, Annual

3.6 Paving - 2023

Unmitigated Construction Off-Site

	ROG	NOx	CO	SO2	Fugitive PM10	Exhaust PM10	PM10 Total	Fugitive PM2.5	Exhaust PM2.5	PM2.5 Total	Bio- CO2	NBio- CO2	Total CO2	CH4	N2O	CO2e
Category	tons/yr										MT/yr					
Hauling	0.0000	0.0000	0.0000	0.0000	0.0000	0.0000	0.0000	0.0000	0.0000	0.0000	0.0000	0.0000	0.0000	0.0000	0.0000	0.0000
Vendor	0.0000	0.0000	0.0000	0.0000	0.0000	0.0000	0.0000	0.0000	0.0000	0.0000	0.0000	0.0000	0.0000	0.0000	0.0000	0.0000
Worker	2.8000e-004	1.9000e-004	2.2300e-003	1.0000e-005	7.3000e-004	1.0000e-005	7.3000e-004	1.9000e-004	1.0000e-005	2.0000e-004	0.0000	0.6156	0.6156	2.0000e-005	0.0000	0.6160
Total	2.8000e-004	1.9000e-004	2.2300e-003	1.0000e-005	7.3000e-004	1.0000e-005	7.3000e-004	1.9000e-004	1.0000e-005	2.0000e-004	0.0000	0.6156	0.6156	2.0000e-005	0.0000	0.6160

Mitigated Construction On-Site

	ROG	NOx	CO	SO2	Fugitive PM10	Exhaust PM10	PM10 Total	Fugitive PM2.5	Exhaust PM2.5	PM2.5 Total	Bio- CO2	NBio- CO2	Total CO2	CH4	N2O	CO2e
Category	tons/yr										MT/yr					
Off-Road	6.7100e-003	0.0663	0.0948	1.5000e-004		3.3200e-003	3.3200e-003		3.0500e-003	3.0500e-003	0.0000	13.0175	13.0175	4.2100e-003	0.0000	13.1227
Paving	0.0000					0.0000	0.0000		0.0000	0.0000	0.0000	0.0000	0.0000	0.0000	0.0000	0.0000
Total	6.7100e-003	0.0663	0.0948	1.5000e-004		3.3200e-003	3.3200e-003		3.0500e-003	3.0500e-003	0.0000	13.0175	13.0175	4.2100e-003	0.0000	13.1227

Village South Specific Plan (Proposed) - Los Angeles-South Coast County, Annual

3.6 Paving - 2023

Mitigated Construction Off-Site

	ROG	NOx	CO	SO2	Fugitive PM10	Exhaust PM10	PM10 Total	Fugitive PM2.5	Exhaust PM2.5	PM2.5 Total	Bio- CO2	NBio- CO2	Total CO2	CH4	N2O	CO2e
Category	tons/yr										MT/yr					
Hauling	0.0000	0.0000	0.0000	0.0000	0.0000	0.0000	0.0000	0.0000	0.0000	0.0000	0.0000	0.0000	0.0000	0.0000	0.0000	0.0000
Vendor	0.0000	0.0000	0.0000	0.0000	0.0000	0.0000	0.0000	0.0000	0.0000	0.0000	0.0000	0.0000	0.0000	0.0000	0.0000	0.0000
Worker	2.8000e-004	1.9000e-004	2.2300e-003	1.0000e-005	7.3000e-004	1.0000e-005	7.3000e-004	1.9000e-004	1.0000e-005	2.0000e-004	0.0000	0.6156	0.6156	2.0000e-005	0.0000	0.6160
Total	2.8000e-004	1.9000e-004	2.2300e-003	1.0000e-005	7.3000e-004	1.0000e-005	7.3000e-004	1.9000e-004	1.0000e-005	2.0000e-004	0.0000	0.6156	0.6156	2.0000e-005	0.0000	0.6160

3.6 Paving - 2024

Unmitigated Construction On-Site

	ROG	NOx	CO	SO2	Fugitive PM10	Exhaust PM10	PM10 Total	Fugitive PM2.5	Exhaust PM2.5	PM2.5 Total	Bio- CO2	NBio- CO2	Total CO2	CH4	N2O	CO2e
Category	tons/yr										MT/yr					
Off-Road	0.0109	0.1048	0.1609	2.5000e-004		5.1500e-003	5.1500e-003		4.7400e-003	4.7400e-003	0.0000	22.0292	22.0292	7.1200e-003	0.0000	22.2073
Paving	0.0000					0.0000	0.0000		0.0000	0.0000	0.0000	0.0000	0.0000	0.0000	0.0000	0.0000
Total	0.0109	0.1048	0.1609	2.5000e-004		5.1500e-003	5.1500e-003		4.7400e-003	4.7400e-003	0.0000	22.0292	22.0292	7.1200e-003	0.0000	22.2073

Village South Specific Plan (Proposed) - Los Angeles-South Coast County, Annual

3.6 Paving - 2024

Unmitigated Construction Off-Site

	ROG	NOx	CO	SO2	Fugitive PM10	Exhaust PM10	PM10 Total	Fugitive PM2.5	Exhaust PM2.5	PM2.5 Total	Bio- CO2	NBio- CO2	Total CO2	CH4	N2O	CO2e
Category	tons/yr										MT/yr					
Hauling	0.0000	0.0000	0.0000	0.0000	0.0000	0.0000	0.0000	0.0000	0.0000	0.0000	0.0000	0.0000	0.0000	0.0000	0.0000	0.0000
Vendor	0.0000	0.0000	0.0000	0.0000	0.0000	0.0000	0.0000	0.0000	0.0000	0.0000	0.0000	0.0000	0.0000	0.0000	0.0000	0.0000
Worker	4.4000e-004	2.9000e-004	3.5100e-003	1.0000e-005	1.2300e-003	1.0000e-005	1.2400e-003	3.3000e-004	1.0000e-005	3.4000e-004	0.0000	1.0094	1.0094	3.0000e-005	0.0000	1.0100
Total	4.4000e-004	2.9000e-004	3.5100e-003	1.0000e-005	1.2300e-003	1.0000e-005	1.2400e-003	3.3000e-004	1.0000e-005	3.4000e-004	0.0000	1.0094	1.0094	3.0000e-005	0.0000	1.0100

Mitigated Construction On-Site

	ROG	NOx	CO	SO2	Fugitive PM10	Exhaust PM10	PM10 Total	Fugitive PM2.5	Exhaust PM2.5	PM2.5 Total	Bio- CO2	NBio- CO2	Total CO2	CH4	N2O	CO2e
Category	tons/yr										MT/yr					
Off-Road	0.0109	0.1048	0.1609	2.5000e-004		5.1500e-003	5.1500e-003		4.7400e-003	4.7400e-003	0.0000	22.0292	22.0292	7.1200e-003	0.0000	22.2073
Paving	0.0000					0.0000	0.0000		0.0000	0.0000	0.0000	0.0000	0.0000	0.0000	0.0000	0.0000
Total	0.0109	0.1048	0.1609	2.5000e-004		5.1500e-003	5.1500e-003		4.7400e-003	4.7400e-003	0.0000	22.0292	22.0292	7.1200e-003	0.0000	22.2073

Village South Specific Plan (Proposed) - Los Angeles-South Coast County, Annual

3.6 Paving - 2024

Mitigated Construction Off-Site

	ROG	NOx	CO	SO2	Fugitive PM10	Exhaust PM10	PM10 Total	Fugitive PM2.5	Exhaust PM2.5	PM2.5 Total	Bio- CO2	NBio- CO2	Total CO2	CH4	N2O	CO2e
Category	tons/yr										MT/yr					
Hauling	0.0000	0.0000	0.0000	0.0000	0.0000	0.0000	0.0000	0.0000	0.0000	0.0000	0.0000	0.0000	0.0000	0.0000	0.0000	0.0000
Vendor	0.0000	0.0000	0.0000	0.0000	0.0000	0.0000	0.0000	0.0000	0.0000	0.0000	0.0000	0.0000	0.0000	0.0000	0.0000	0.0000
Worker	4.4000e-004	2.9000e-004	3.5100e-003	1.0000e-005	1.2300e-003	1.0000e-005	1.2400e-003	3.3000e-004	1.0000e-005	3.4000e-004	0.0000	1.0094	1.0094	3.0000e-005	0.0000	1.0100
Total	4.4000e-004	2.9000e-004	3.5100e-003	1.0000e-005	1.2300e-003	1.0000e-005	1.2400e-003	3.3000e-004	1.0000e-005	3.4000e-004	0.0000	1.0094	1.0094	3.0000e-005	0.0000	1.0100

3.7 Architectural Coating - 2024

Unmitigated Construction On-Site

	ROG	NOx	CO	SO2	Fugitive PM10	Exhaust PM10	PM10 Total	Fugitive PM2.5	Exhaust PM2.5	PM2.5 Total	Bio- CO2	NBio- CO2	Total CO2	CH4	N2O	CO2e
Category	tons/yr										MT/yr					
Archit. Coating	4.1372					0.0000	0.0000		0.0000	0.0000	0.0000	0.0000	0.0000	0.0000	0.0000	0.0000
Off-Road	3.1600e-003	0.0213	0.0317	5.0000e-005		1.0700e-003	1.0700e-003		1.0700e-003	1.0700e-003	0.0000	4.4682	4.4682	2.5000e-004	0.0000	4.4745
Total	4.1404	0.0213	0.0317	5.0000e-005		1.0700e-003	1.0700e-003		1.0700e-003	1.0700e-003	0.0000	4.4682	4.4682	2.5000e-004	0.0000	4.4745

Village South Specific Plan (Proposed) - Los Angeles-South Coast County, Annual

3.7 Architectural Coating - 2024

Unmitigated Construction Off-Site

	ROG	NOx	CO	SO2	Fugitive PM10	Exhaust PM10	PM10 Total	Fugitive PM2.5	Exhaust PM2.5	PM2.5 Total	Bio- CO2	NBio- CO2	Total CO2	CH4	N2O	CO2e
Category	tons/yr										MT/yr					
Hauling	0.0000	0.0000	0.0000	0.0000	0.0000	0.0000	0.0000	0.0000	0.0000	0.0000	0.0000	0.0000	0.0000	0.0000	0.0000	0.0000
Vendor	0.0000	0.0000	0.0000	0.0000	0.0000	0.0000	0.0000	0.0000	0.0000	0.0000	0.0000	0.0000	0.0000	0.0000	0.0000	0.0000
Worker	7.4800e-003	4.9300e-003	0.0596	1.9000e-004	0.0209	1.6000e-004	0.0211	5.5500e-003	1.5000e-004	5.7000e-003	0.0000	17.1287	17.1287	4.3000e-004	0.0000	17.1394
Total	7.4800e-003	4.9300e-003	0.0596	1.9000e-004	0.0209	1.6000e-004	0.0211	5.5500e-003	1.5000e-004	5.7000e-003	0.0000	17.1287	17.1287	4.3000e-004	0.0000	17.1394

Mitigated Construction On-Site

	ROG	NOx	CO	SO2	Fugitive PM10	Exhaust PM10	PM10 Total	Fugitive PM2.5	Exhaust PM2.5	PM2.5 Total	Bio- CO2	NBio- CO2	Total CO2	CH4	N2O	CO2e
Category	tons/yr										MT/yr					
Archit. Coating	4.1372					0.0000	0.0000		0.0000	0.0000	0.0000	0.0000	0.0000	0.0000	0.0000	0.0000
Off-Road	3.1600e-003	0.0213	0.0317	5.0000e-005		1.0700e-003	1.0700e-003		1.0700e-003	1.0700e-003	0.0000	4.4682	4.4682	2.5000e-004	0.0000	4.4745
Total	4.1404	0.0213	0.0317	5.0000e-005		1.0700e-003	1.0700e-003		1.0700e-003	1.0700e-003	0.0000	4.4682	4.4682	2.5000e-004	0.0000	4.4745

Village South Specific Plan (Proposed) - Los Angeles-South Coast County, Annual

3.7 Architectural Coating - 2024

Mitigated Construction Off-Site

	ROG	NOx	CO	SO2	Fugitive PM10	Exhaust PM10	PM10 Total	Fugitive PM2.5	Exhaust PM2.5	PM2.5 Total	Bio- CO2	NBio- CO2	Total CO2	CH4	N2O	CO2e
Category	tons/yr										MT/yr					
Hauling	0.0000	0.0000	0.0000	0.0000	0.0000	0.0000	0.0000	0.0000	0.0000	0.0000	0.0000	0.0000	0.0000	0.0000	0.0000	0.0000
Vendor	0.0000	0.0000	0.0000	0.0000	0.0000	0.0000	0.0000	0.0000	0.0000	0.0000	0.0000	0.0000	0.0000	0.0000	0.0000	0.0000
Worker	7.4800e-003	4.9300e-003	0.0596	1.9000e-004	0.0209	1.6000e-004	0.0211	5.5500e-003	1.5000e-004	5.7000e-003	0.0000	17.1287	17.1287	4.3000e-004	0.0000	17.1394
Total	7.4800e-003	4.9300e-003	0.0596	1.9000e-004	0.0209	1.6000e-004	0.0211	5.5500e-003	1.5000e-004	5.7000e-003	0.0000	17.1287	17.1287	4.3000e-004	0.0000	17.1394

4.0 Operational Detail - Mobile

4.1 Mitigation Measures Mobile

Village South Specific Plan (Proposed) - Los Angeles-South Coast County, Annual

	ROG	NOx	CO	SO2	Fugitive PM10	Exhaust PM10	PM10 Total	Fugitive PM2.5	Exhaust PM2.5	PM2.5 Total	Bio- CO2	NBio- CO2	Total CO2	CH4	N2O	CO2e
Category	tons/yr										MT/yr					
Mitigated	1.5857	7.9962	19.1834	0.0821	7.7979	0.0580	7.8559	2.0895	0.0539	2.1434	0.0000	7,620.4986	7,620.4986	0.3407	0.0000	7,629.0162
Unmitigated	1.5857	7.9962	19.1834	0.0821	7.7979	0.0580	7.8559	2.0895	0.0539	2.1434	0.0000	7,620.4986	7,620.4986	0.3407	0.0000	7,629.0162

4.2 Trip Summary Information

Land Use	Average Daily Trip Rate			Unmitigated	Mitigated
	Weekday	Saturday	Sunday	Annual VMT	Annual VMT
Apartments Low Rise	145.75	154.25	154.00	506,227	506,227
Apartments Mid Rise	4,026.75	3,773.25	4075.50	13,660,065	13,660,065
General Office Building	288.45	62.55	31.05	706,812	706,812
High Turnover (Sit Down Restaurant)	2,368.80	2,873.52	2817.72	3,413,937	3,413,937
Hotel	192.00	187.50	160.00	445,703	445,703
Quality Restaurant	501.12	511.92	461.20	707,488	707,488
Regional Shopping Center	528.08	601.44	357.84	1,112,221	1,112,221
Total	8,050.95	8,164.43	8,057.31	20,552,452	20,552,452

4.3 Trip Type Information

Village South Specific Plan (Proposed) - Los Angeles-South Coast County, Annual

Land Use	Miles			Trip %			Trip Purpose %		
	H-W or C-W	H-S or C-C	H-O or C-NW	H-W or C-W	H-S or C-C	H-O or C-NW	Primary	Diverted	Pass-by
Apartments Low Rise	14.70	5.90	8.70	40.20	19.20	40.60	86	11	3
Apartments Mid Rise	14.70	5.90	8.70	40.20	19.20	40.60	86	11	3
General Office Building	16.60	8.40	6.90	33.00	48.00	19.00	77	19	4
High Turnover (Sit Down Restaurant)	16.60	8.40	6.90	8.50	72.50	19.00	37	20	43
Hotel	16.60	8.40	6.90	19.40	61.60	19.00	58	38	4
Quality Restaurant	16.60	8.40	6.90	12.00	69.00	19.00	38	18	44
Regional Shopping Center	16.60	8.40	6.90	16.30	64.70	19.00	54	35	11

4.4 Fleet Mix

Land Use	LDA	LDT1	LDT2	MDV	LHD1	LHD2	MHD	HHD	OBUS	UBUS	MCY	SBUS	MH
Apartments Low Rise	0.543088	0.044216	0.209971	0.116369	0.014033	0.006332	0.021166	0.033577	0.002613	0.001817	0.005285	0.000712	0.000821
Apartments Mid Rise	0.543088	0.044216	0.209971	0.116369	0.014033	0.006332	0.021166	0.033577	0.002613	0.001817	0.005285	0.000712	0.000821
General Office Building	0.543088	0.044216	0.209971	0.116369	0.014033	0.006332	0.021166	0.033577	0.002613	0.001817	0.005285	0.000712	0.000821
High Turnover (Sit Down Restaurant)	0.543088	0.044216	0.209971	0.116369	0.014033	0.006332	0.021166	0.033577	0.002613	0.001817	0.005285	0.000712	0.000821
Hotel	0.543088	0.044216	0.209971	0.116369	0.014033	0.006332	0.021166	0.033577	0.002613	0.001817	0.005285	0.000712	0.000821
Quality Restaurant	0.543088	0.044216	0.209971	0.116369	0.014033	0.006332	0.021166	0.033577	0.002613	0.001817	0.005285	0.000712	0.000821
Regional Shopping Center	0.543088	0.044216	0.209971	0.116369	0.014033	0.006332	0.021166	0.033577	0.002613	0.001817	0.005285	0.000712	0.000821

5.0 Energy Detail

Historical Energy Use: N

5.1 Mitigation Measures Energy

Village South Specific Plan (Proposed) - Los Angeles-South Coast County, Annual

	ROG	NOx	CO	SO2	Fugitive PM10	Exhaust PM10	PM10 Total	Fugitive PM2.5	Exhaust PM2.5	PM2.5 Total	Bio- CO2	NBio- CO2	Total CO2	CH4	N2O	CO2e
Category	tons/yr										MT/yr					
Electricity Mitigated							0.0000	0.0000		0.0000	0.0000	2,512.6465	2,512.6465	0.1037	0.0215	2,521.6356
Electricity Unmitigated							0.0000	0.0000		0.0000	0.0000	2,512.6465	2,512.6465	0.1037	0.0215	2,521.6356
NaturalGas Mitigated	0.1398	1.2312	0.7770	7.6200e-003		0.0966	0.0966		0.0966	0.0966	0.0000	1,383.4267	1,383.4267	0.0265	0.0254	1,391.6478
NaturalGas Unmitigated	0.1398	1.2312	0.7770	7.6200e-003		0.0966	0.0966		0.0966	0.0966	0.0000	1,383.4267	1,383.4267	0.0265	0.0254	1,391.6478

Village South Specific Plan (Proposed) - Los Angeles-South Coast County, Annual

5.2 Energy by Land Use - NaturalGas

Unmitigated

	NaturalGas Use	ROG	NOx	CO	SO2	Fugitive PM10	Exhaust PM10	PM10 Total	Fugitive PM2.5	Exhaust PM2.5	PM2.5 Total	Bio- CO2	NBio- CO2	Total CO2	CH4	N2O	CO2e
Land Use	kBTU/yr	tons/yr										MT/yr					
Apartments Low Rise	408494	2.2000e-003	0.0188	8.0100e-003	1.2000e-004		1.5200e-003	1.5200e-003		1.5200e-003	1.5200e-003	0.0000	21.7988	21.7988	4.2000e-004	4.0000e-004	21.9284
Apartments Mid Rise	1.30613e+007	0.0704	0.6018	0.2561	3.8400e-003		0.0487	0.0487		0.0487	0.0487	0.0000	696.9989	696.9989	0.0134	0.0128	701.1408
General Office Building	468450	2.5300e-003	0.0230	0.0193	1.4000e-004		1.7500e-003	1.7500e-003		1.7500e-003	1.7500e-003	0.0000	24.9983	24.9983	4.8000e-004	4.6000e-004	25.1468
High Turnover (Sit Down Restaurant)	8.30736e+006	0.0448	0.4072	0.3421	2.4400e-003		0.0310	0.0310		0.0310	0.0310	0.0000	443.3124	443.3124	8.5000e-003	8.1300e-003	445.9468
Hotel	1.74095e+006	9.3900e-003	0.0853	0.0717	5.1000e-004		6.4900e-003	6.4900e-003		6.4900e-003	6.4900e-003	0.0000	92.9036	92.9036	1.7800e-003	1.7000e-003	93.4557
Quality Restaurant	1.84608e+006	9.9500e-003	0.0905	0.0760	5.4000e-004		6.8800e-003	6.8800e-003		6.8800e-003	6.8800e-003	0.0000	98.5139	98.5139	1.8900e-003	1.8100e-003	99.0993
Regional Shopping Center	91840	5.0000e-004	4.5000e-003	3.7800e-003	3.0000e-005		3.4000e-004	3.4000e-004		3.4000e-004	3.4000e-004	0.0000	4.9009	4.9009	9.0000e-005	9.0000e-005	4.9301
Total		0.1398	1.2312	0.7770	7.6200e-003		0.0966	0.0966		0.0966	0.0966	0.0000	1,383.4268	1,383.4268	0.0265	0.0254	1,391.6478

Village South Specific Plan (Proposed) - Los Angeles-South Coast County, Annual

5.2 Energy by Land Use - NaturalGas

Mitigated

	NaturalGas Use	ROG	NOx	CO	SO2	Fugitive PM10	Exhaust PM10	PM10 Total	Fugitive PM2.5	Exhaust PM2.5	PM2.5 Total	Bio- CO2	NBio- CO2	Total CO2	CH4	N2O	CO2e
Land Use	kBTU/yr	tons/yr										MT/yr					
Apartments Low Rise	408494	2.2000e-003	0.0188	8.0100e-003	1.2000e-004		1.5200e-003	1.5200e-003		1.5200e-003	1.5200e-003	0.0000	21.7988	21.7988	4.2000e-004	4.0000e-004	21.9284
Apartments Mid Rise	1.30613e+007	0.0704	0.6018	0.2561	3.8400e-003		0.0487	0.0487		0.0487	0.0487	0.0000	696.9989	696.9989	0.0134	0.0128	701.1408
General Office Building	468450	2.5300e-003	0.0230	0.0193	1.4000e-004		1.7500e-003	1.7500e-003		1.7500e-003	1.7500e-003	0.0000	24.9983	24.9983	4.8000e-004	4.6000e-004	25.1468
High Turnover (Sit Down Restaurant)	8.30736e+006	0.0448	0.4072	0.3421	2.4400e-003		0.0310	0.0310		0.0310	0.0310	0.0000	443.3124	443.3124	8.5000e-003	8.1300e-003	445.9468
Hotel	1.74095e+006	9.3900e-003	0.0853	0.0717	5.1000e-004		6.4900e-003	6.4900e-003		6.4900e-003	6.4900e-003	0.0000	92.9036	92.9036	1.7800e-003	1.7000e-003	93.4557
Quality Restaurant	1.84608e+006	9.9500e-003	0.0905	0.0760	5.4000e-004		6.8800e-003	6.8800e-003		6.8800e-003	6.8800e-003	0.0000	98.5139	98.5139	1.8900e-003	1.8100e-003	99.0993
Regional Shopping Center	91840	5.0000e-004	4.5000e-003	3.7800e-003	3.0000e-005		3.4000e-004	3.4000e-004		3.4000e-004	3.4000e-004	0.0000	4.9009	4.9009	9.0000e-005	9.0000e-005	4.9301
Total		0.1398	1.2312	0.7770	7.6200e-003		0.0966	0.0966		0.0966	0.0966	0.0000	1,383.4268	1,383.4268	0.0265	0.0254	1,391.6478

Village South Specific Plan (Proposed) - Los Angeles-South Coast County, Annual

5.3 Energy by Land Use - Electricity

Unmitigated

	Electricity Use	Total CO2	CH4	N2O	CO2e
Land Use	kWh/yr	MT/yr			
Apartments Low Rise	106010	33.7770	1.3900e-003	2.9000e-004	33.8978
Apartments Mid Rise	3.94697e+006	1,257.5879	0.0519	0.0107	1,262.0869
General Office Building	584550	186.2502	7.6900e-003	1.5900e-003	186.9165
High Turnover (Sit Down Restaurant)	1.58904e+006	506.3022	0.0209	4.3200e-003	508.1135
Hotel	550308	175.3399	7.2400e-003	1.5000e-003	175.9672
Quality Restaurant	353120	112.5116	4.6500e-003	9.6000e-004	112.9141
Regional Shopping Center	756000	240.8778	9.9400e-003	2.0600e-003	241.7395
Total		2,512.6465	0.1037	0.0215	2,521.6356

Village South Specific Plan (Proposed) - Los Angeles-South Coast County, Annual

5.3 Energy by Land Use - Electricity

Mitigated

	Electricity Use	Total CO2	CH4	N2O	CO2e
Land Use	kWh/yr	MT/yr			
Apartments Low Rise	106010	33.7770	1.3900e-003	2.9000e-004	33.8978
Apartments Mid Rise	3.94697e+006	1,257.5879	0.0519	0.0107	1,262.0869
General Office Building	584550	186.2502	7.6900e-003	1.5900e-003	186.9165
High Turnover (Sit Down Restaurant)	1.58904e+006	506.3022	0.0209	4.3200e-003	508.1135
Hotel	550308	175.3399	7.2400e-003	1.5000e-003	175.9672
Quality Restaurant	353120	112.5116	4.6500e-003	9.6000e-004	112.9141
Regional Shopping Center	756000	240.8778	9.9400e-003	2.0600e-003	241.7395
Total		2,512.6465	0.1037	0.0215	2,521.6356

6.0 Area Detail

6.1 Mitigation Measures Area

Village South Specific Plan (Proposed) - Los Angeles-South Coast County, Annual

	ROG	NOx	CO	SO2	Fugitive PM10	Exhaust PM10	PM10 Total	Fugitive PM2.5	Exhaust PM2.5	PM2.5 Total	Bio- CO2	NBio- CO2	Total CO2	CH4	N2O	CO2e
Category	tons/yr										MT/yr					
Mitigated	5.1437	0.2950	10.3804	1.6700e-003		0.0714	0.0714		0.0714	0.0714	0.0000	220.9670	220.9670	0.0201	3.7400e-003	222.5835
Unmitigated	5.1437	0.2950	10.3804	1.6700e-003		0.0714	0.0714		0.0714	0.0714	0.0000	220.9670	220.9670	0.0201	3.7400e-003	222.5835

6.2 Area by SubCategory

Unmitigated

	ROG	NOx	CO	SO2	Fugitive PM10	Exhaust PM10	PM10 Total	Fugitive PM2.5	Exhaust PM2.5	PM2.5 Total	Bio- CO2	NBio- CO2	Total CO2	CH4	N2O	CO2e
SubCategory	tons/yr										MT/yr					
Architectural Coating	0.4137					0.0000	0.0000		0.0000	0.0000	0.0000	0.0000	0.0000	0.0000	0.0000	0.0000
Consumer Products	4.3998					0.0000	0.0000		0.0000	0.0000	0.0000	0.0000	0.0000	0.0000	0.0000	0.0000
Hearth	0.0206	0.1763	0.0750	1.1200e-003		0.0143	0.0143		0.0143	0.0143	0.0000	204.1166	204.1166	3.9100e-003	3.7400e-003	205.3295
Landscaping	0.3096	0.1187	10.3054	5.4000e-004		0.0572	0.0572		0.0572	0.0572	0.0000	16.8504	16.8504	0.0161	0.0000	17.2540
Total	5.1437	0.2950	10.3804	1.6600e-003		0.0714	0.0714		0.0714	0.0714	0.0000	220.9670	220.9670	0.0201	3.7400e-003	222.5835

Village South Specific Plan (Proposed) - Los Angeles-South Coast County, Annual

6.2 Area by SubCategory

Mitigated

	ROG	NOx	CO	SO2	Fugitive PM10	Exhaust PM10	PM10 Total	Fugitive PM2.5	Exhaust PM2.5	PM2.5 Total	Bio- CO2	NBio- CO2	Total CO2	CH4	N2O	CO2e
SubCategory	tons/yr										MT/yr					
Architectural Coating	0.4137					0.0000	0.0000		0.0000	0.0000	0.0000	0.0000	0.0000	0.0000	0.0000	0.0000
Consumer Products	4.3998					0.0000	0.0000		0.0000	0.0000	0.0000	0.0000	0.0000	0.0000	0.0000	0.0000
Hearth	0.0206	0.1763	0.0750	1.1200e-003		0.0143	0.0143		0.0143	0.0143	0.0000	204.1166	204.1166	3.9100e-003	3.7400e-003	205.3295
Landscaping	0.3096	0.1187	10.3054	5.4000e-004		0.0572	0.0572		0.0572	0.0572	0.0000	16.8504	16.8504	0.0161	0.0000	17.2540
Total	5.1437	0.2950	10.3804	1.6600e-003		0.0714	0.0714		0.0714	0.0714	0.0000	220.9670	220.9670	0.0201	3.7400e-003	222.5835

7.0 Water Detail

7.1 Mitigation Measures Water

Village South Specific Plan (Proposed) - Los Angeles-South Coast County, Annual

	Total CO2	CH4	N2O	CO2e
Category	MT/yr			
Mitigated	585.8052	3.0183	0.0755	683.7567
Unmitigated	585.8052	3.0183	0.0755	683.7567

Village South Specific Plan (Proposed) - Los Angeles-South Coast County, Annual

7.2 Water by Land Use

Unmitigated

	Indoor/Outdoor Use	Total CO2	CH4	N2O	CO2e
Land Use	Mgal	MT/yr			
Apartments Low Rise	1.62885 / 1.02688	10.9095	0.0535	1.3400e-003	12.6471
Apartments Mid Rise	63.5252 / 40.0485	425.4719	2.0867	0.0523	493.2363
General Office Building	7.99802 / 4.90201	53.0719	0.2627	6.5900e-003	61.6019
High Turnover (Sit Down Restaurant)	10.9272 / 0.697482	51.2702	0.3580	8.8200e-003	62.8482
Hotel	1.26834 / 0.140927	6.1633	0.0416	1.0300e-003	7.5079
Quality Restaurant	2.42827 / 0.154996	11.3934	0.0796	1.9600e-003	13.9663
Regional Shopping Center	4.14806 / 2.54236	27.5250	0.1363	3.4200e-003	31.9490
Total		585.8052	3.0183	0.0755	683.7567

Village South Specific Plan (Proposed) - Los Angeles-South Coast County, Annual

7.2 Water by Land Use

Mitigated

	Indoor/Outdoor Use	Total CO2	CH4	N2O	CO2e
Land Use	Mgal	MT/yr			
Apartments Low Rise	1.62885 / 1.02688	10.9095	0.0535	1.3400e-003	12.6471
Apartments Mid Rise	63.5252 / 40.0485	425.4719	2.0867	0.0523	493.2363
General Office Building	7.99802 / 4.90201	53.0719	0.2627	6.5900e-003	61.6019
High Turnover (Sit Down Restaurant)	10.9272 / 0.697482	51.2702	0.3580	8.8200e-003	62.8482
Hotel	1.26834 / 0.140927	6.1633	0.0416	1.0300e-003	7.5079
Quality Restaurant	2.42827 / 0.154996	11.3934	0.0796	1.9600e-003	13.9663
Regional Shopping Center	4.14806 / 2.54236	27.5250	0.1363	3.4200e-003	31.9490
Total		585.8052	3.0183	0.0755	683.7567

8.0 Waste Detail

8.1 Mitigation Measures Waste

Village South Specific Plan (Proposed) - Los Angeles-South Coast County, Annual

Category/Year

	Total CO2	CH4	N2O	CO2e
	MT/yr			
Mitigated	207.8079	12.2811	0.0000	514.8354
Unmitigated	207.8079	12.2811	0.0000	514.8354

Village South Specific Plan (Proposed) - Los Angeles-South Coast County, Annual

8.2 Waste by Land Use

Unmitigated

	Waste Disposed	Total CO2	CH4	N2O	CO2e
Land Use	tons	MT/yr			
Apartments Low Rise	11.5	2.3344	0.1380	0.0000	5.7834
Apartments Mid Rise	448.5	91.0415	5.3804	0.0000	225.5513
General Office Building	41.85	8.4952	0.5021	0.0000	21.0464
High Turnover (Sit Down Restaurant)	428.4	86.9613	5.1393	0.0000	215.4430
Hotel	27.38	5.5579	0.3285	0.0000	13.7694
Quality Restaurant	7.3	1.4818	0.0876	0.0000	3.6712
Regional Shopping Center	58.8	11.9359	0.7054	0.0000	29.5706
Total		207.8079	12.2811	0.0000	514.8354

Village South Specific Plan (Proposed) - Los Angeles-South Coast County, Annual

8.2 Waste by Land Use

Mitigated

	Waste Disposed	Total CO2	CH4	N2O	CO2e
Land Use	tons	MT/yr			
Apartments Low Rise	11.5	2.3344	0.1380	0.0000	5.7834
Apartments Mid Rise	448.5	91.0415	5.3804	0.0000	225.5513
General Office Building	41.85	8.4952	0.5021	0.0000	21.0464
High Turnover (Sit Down Restaurant)	428.4	86.9613	5.1393	0.0000	215.4430
Hotel	27.38	5.5579	0.3285	0.0000	13.7694
Quality Restaurant	7.3	1.4818	0.0876	0.0000	3.6712
Regional Shopping Center	58.8	11.9359	0.7054	0.0000	29.5706
Total		207.8079	12.2811	0.0000	514.8354

9.0 Operational Offroad

Equipment Type	Number	Hours/Day	Days/Year	Horse Power	Load Factor	Fuel Type
----------------	--------	-----------	-----------	-------------	-------------	-----------

10.0 Stationary Equipment

Fire Pumps and Emergency Generators

Equipment Type	Number	Hours/Day	Hours/Year	Horse Power	Load Factor	Fuel Type
----------------	--------	-----------	------------	-------------	-------------	-----------

Village South Specific Plan (Proposed) - Los Angeles-South Coast County, Annual

Boilers

Equipment Type	Number	Heat Input/Day	Heat Input/Year	Boiler Rating	Fuel Type
----------------	--------	----------------	-----------------	---------------	-----------

User Defined Equipment

Equipment Type	Number
----------------	--------

11.0 Vegetation

Village South Specific Plan (Proposed) - Los Angeles-South Coast County, Summer

Village South Specific Plan (Proposed)
Los Angeles-South Coast County, Summer

1.0 Project Characteristics

1.1 Land Usage

Land Uses	Size	Metric	Lot Acreage	Floor Surface Area	Population
General Office Building	45.00	1000sqft	1.03	45,000.00	0
High Turnover (Sit Down Restaurant)	36.00	1000sqft	0.83	36,000.00	0
Hotel	50.00	Room	1.67	72,600.00	0
Quality Restaurant	8.00	1000sqft	0.18	8,000.00	0
Apartments Low Rise	25.00	Dwelling Unit	1.56	25,000.00	72
Apartments Mid Rise	975.00	Dwelling Unit	25.66	975,000.00	2789
Regional Shopping Center	56.00	1000sqft	1.29	56,000.00	0

1.2 Other Project Characteristics

Urbanization	Urban	Wind Speed (m/s)	2.2	Precipitation Freq (Days)	33
Climate Zone	9			Operational Year	2028
Utility Company	Southern California Edison				
CO2 Intensity (lb/MW hr)	702.44	CH4 Intensity (lb/MW hr)	0.029	N2O Intensity (lb/MW hr)	0.006

1.3 User Entered Comments & Non-Default Data

Village South Specific Plan (Proposed) - Los Angeles-South Coast County, Summer

Project Characteristics - Consistent with the DEIR's model.

Land Use - See SWAPE comment regarding residential and retail land uses.

Construction Phase - See SWAPE comment regarding individual construction phase lengths.

Demolition - Consistent with the DEIR's model. See SWAPE comment regarding demolition.

Vehicle Trips - Saturday trips consistent with the DEIR's model. See SWAPE comment regarding weekday and Sunday trips.

Woodstoves - Woodstoves and wood-burning fireplaces consistent with the DEIR's model. See SWAPE comment regarding gas fireplaces.

Energy Use -

Construction Off-road Equipment Mitigation - See SWAPE comment on construction-related mitigation.

Area Mitigation - See SWAPE comment regarding operational mitigation measures.

Water Mitigation - See SWAPE comment regarding operational mitigation measures.

Trips and VMT - Local hire provision

Table Name	Column Name	Default Value	New Value
tblFireplaces	FireplaceWoodMass	1,019.20	0.00
tblFireplaces	FireplaceWoodMass	1,019.20	0.00
tblFireplaces	NumberWood	1.25	0.00
tblFireplaces	NumberWood	48.75	0.00
tblTripsAndVMT	WorkerTripLength	14.70	10.00
tblTripsAndVMT	WorkerTripLength	14.70	10.00
tblTripsAndVMT	WorkerTripLength	14.70	10.00
tblTripsAndVMT	WorkerTripLength	14.70	10.00
tblTripsAndVMT	WorkerTripLength	14.70	10.00
tblTripsAndVMT	WorkerTripLength	14.70	10.00
tblVehicleTrips	ST_TR	7.16	6.17
tblVehicleTrips	ST_TR	6.39	3.87
tblVehicleTrips	ST_TR	2.46	1.39
tblVehicleTrips	ST_TR	158.37	79.82

Village South Specific Plan (Proposed) - Los Angeles-South Coast County, Summer

tblVehicleTrips	ST_TR	8.19	3.75
tblVehicleTrips	ST_TR	94.36	63.99
tblVehicleTrips	ST_TR	49.97	10.74
tblVehicleTrips	SU_TR	6.07	6.16
tblVehicleTrips	SU_TR	5.86	4.18
tblVehicleTrips	SU_TR	1.05	0.69
tblVehicleTrips	SU_TR	131.84	78.27
tblVehicleTrips	SU_TR	5.95	3.20
tblVehicleTrips	SU_TR	72.16	57.65
tblVehicleTrips	SU_TR	25.24	6.39
tblVehicleTrips	WD_TR	6.59	5.83
tblVehicleTrips	WD_TR	6.65	4.13
tblVehicleTrips	WD_TR	11.03	6.41
tblVehicleTrips	WD_TR	127.15	65.80
tblVehicleTrips	WD_TR	8.17	3.84
tblVehicleTrips	WD_TR	89.95	62.64
tblVehicleTrips	WD_TR	42.70	9.43
tblWoodstoves	NumberCatalytic	1.25	0.00
tblWoodstoves	NumberCatalytic	48.75	0.00
tblWoodstoves	NumberNoncatalytic	1.25	0.00
tblWoodstoves	NumberNoncatalytic	48.75	0.00
tblWoodstoves	WoodstoveDayYear	25.00	0.00
tblWoodstoves	WoodstoveDayYear	25.00	0.00
tblWoodstoves	WoodstoveWoodMass	999.60	0.00
tblWoodstoves	WoodstoveWoodMass	999.60	0.00

2.0 Emissions Summary

Village South Specific Plan (Proposed) - Los Angeles-South Coast County, Summer

2.1 Overall Construction (Maximum Daily Emission)

Unmitigated Construction

	ROG	NOx	CO	SO2	Fugitive PM10	Exhaust PM10	PM10 Total	Fugitive PM2.5	Exhaust PM2.5	PM2.5 Total	Bio- CO2	NBio- CO2	Total CO2	CH4	N2O	CO2e
Year	lb/day										lb/day					
2021	4.2561	46.4415	31.4494	0.0636	18.2032	2.0456	20.2488	9.9670	1.8820	11.8490	0.0000	6,163.4166	6,163.4166	1.9475	0.0000	6,212.1039
2022	4.5441	38.8811	40.8776	0.1240	8.8255	1.6361	10.4616	3.6369	1.5052	5.1421	0.0000	12,493.4403	12,493.4403	1.9485	0.0000	12,518.5707
2023	4.1534	25.7658	38.7457	0.1206	7.0088	0.7592	7.7679	1.8799	0.7136	2.5935	0.0000	12,150.4890	12,150.4890	0.9589	0.0000	12,174.4615
2024	237.0219	9.5478	14.9642	0.0239	1.2171	0.4694	1.2875	0.3229	0.4319	0.4621	0.0000	2,313.1808	2,313.1808	0.7166	0.0000	2,331.0956
Maximum	237.0219	46.4415	40.8776	0.1240	18.2032	2.0456	20.2488	9.9670	1.8820	11.8490	0.0000	12,493.4403	12,493.4403	1.9485	0.0000	12,518.5707

Village South Specific Plan (Proposed) - Los Angeles-South Coast County, Summer

2.2 Overall Operational

Unmitigated Operational

	ROG	NOx	CO	SO2	Fugitive PM10	Exhaust PM10	PM10 Total	Fugitive PM2.5	Exhaust PM2.5	PM2.5 Total	Bio- CO2	NBio- CO2	Total CO2	CH4	N2O	CO2e
Category	lb/day										lb/day					
Area	30.5020	15.0496	88.4430	0.0944		1.5974	1.5974		1.5974	1.5974	0.0000	18,148.59 50	18,148.59 50	0.4874	0.3300	18,259.11 92
Energy	0.7660	6.7462	4.2573	0.0418		0.5292	0.5292		0.5292	0.5292		8,355.983 2	8,355.983 2	0.1602	0.1532	8,405.638 7
Mobile	9.8489	45.4304	114.8495	0.4917	45.9592	0.3360	46.2951	12.2950	0.3119	12.6070		50,306.60 34	50,306.60 34	2.1807		50,361.12 08
Total	41.1168	67.2262	207.5497	0.6278	45.9592	2.4626	48.4217	12.2950	2.4385	14.7336	0.0000	76,811.18 16	76,811.18 16	2.8282	0.4832	77,025.87 86

Mitigated Operational

	ROG	NOx	CO	SO2	Fugitive PM10	Exhaust PM10	PM10 Total	Fugitive PM2.5	Exhaust PM2.5	PM2.5 Total	Bio- CO2	NBio- CO2	Total CO2	CH4	N2O	CO2e
Category	lb/day										lb/day					
Area	30.5020	15.0496	88.4430	0.0944		1.5974	1.5974		1.5974	1.5974	0.0000	18,148.59 50	18,148.59 50	0.4874	0.3300	18,259.11 92
Energy	0.7660	6.7462	4.2573	0.0418		0.5292	0.5292		0.5292	0.5292		8,355.983 2	8,355.983 2	0.1602	0.1532	8,405.638 7
Mobile	9.8489	45.4304	114.8495	0.4917	45.9592	0.3360	46.2951	12.2950	0.3119	12.6070		50,306.60 34	50,306.60 34	2.1807		50,361.12 08
Total	41.1168	67.2262	207.5497	0.6278	45.9592	2.4626	48.4217	12.2950	2.4385	14.7336	0.0000	76,811.18 16	76,811.18 16	2.8282	0.4832	77,025.87 86

Village South Specific Plan (Proposed) - Los Angeles-South Coast County, Summer

	ROG	NOx	CO	SO2	Fugitive PM10	Exhaust PM10	PM10 Total	Fugitive PM2.5	Exhaust PM2.5	PM2.5 Total	Bio- CO2	NBio-CO2	Total CO2	CH4	N2O	CO2e
Percent Reduction	0.00	0.00	0.00	0.00	0.00	0.00	0.00	0.00	0.00	0.00	0.00	0.00	0.00	0.00	0.00	0.00

3.0 Construction Detail

Construction Phase

Phase Number	Phase Name	Phase Type	Start Date	End Date	Num Days Week	Num Days	Phase Description
1	Demolition	Demolition	9/1/2021	10/12/2021	5	30	
2	Site Preparation	Site Preparation	10/13/2021	11/9/2021	5	20	
3	Grading	Grading	11/10/2021	1/11/2022	5	45	
4	Building Construction	Building Construction	1/12/2022	12/12/2023	5	500	
5	Paving	Paving	12/13/2023	1/30/2024	5	35	
6	Architectural Coating	Architectural Coating	1/31/2024	3/19/2024	5	35	

Acres of Grading (Site Preparation Phase): 0

Acres of Grading (Grading Phase): 112.5

Acres of Paving: 0

Residential Indoor: 2,025,000; Residential Outdoor: 675,000; Non-Residential Indoor: 326,400; Non-Residential Outdoor: 108,800; Striped Parking Area: 0 (Architectural Coating – sqft)

OffRoad Equipment

Village South Specific Plan (Proposed) - Los Angeles-South Coast County, Summer

Phase Name	Offroad Equipment Type	Amount	Usage Hours	Horse Power	Load Factor
Demolition	Concrete/Industrial Saws	1	8.00	81	0.73
Demolition	Excavators	3	8.00	158	0.38
Demolition	Rubber Tired Dozers	2	8.00	247	0.40
Site Preparation	Rubber Tired Dozers	3	8.00	247	0.40
Site Preparation	Tractors/Loaders/Backhoes	4	8.00	97	0.37
Grading	Excavators	2	8.00	158	0.38
Grading	Graders	1	8.00	187	0.41
Grading	Rubber Tired Dozers	1	8.00	247	0.40
Grading	Scrapers	2	8.00	367	0.48
Grading	Tractors/Loaders/Backhoes	2	8.00	97	0.37
Building Construction	Cranes	1	7.00	231	0.29
Building Construction	Forklifts	3	8.00	89	0.20
Building Construction	Generator Sets	1	8.00	84	0.74
Building Construction	Tractors/Loaders/Backhoes	3	7.00	97	0.37
Building Construction	Welders	1	8.00	46	0.45
Paving	Pavers	2	8.00	130	0.42
Paving	Paving Equipment	2	8.00	132	0.36
Paving	Rollers	2	8.00	80	0.38
Architectural Coating	Air Compressors	1	6.00	78	0.48

Trips and VMT

Village South Specific Plan (Proposed) - Los Angeles-South Coast County, Summer

Phase Name	Offroad Equipment Count	Worker Trip Number	Vendor Trip Number	Hauling Trip Number	Worker Trip Length	Vendor Trip Length	Hauling Trip Length	Worker Vehicle Class	Vendor Vehicle Class	Hauling Vehicle Class
Demolition	6	15.00	0.00	458.00	10.00	6.90	20.00	LD_Mix	HDT_Mix	HHDT
Site Preparation	7	18.00	0.00	0.00	10.00	6.90	20.00	LD_Mix	HDT_Mix	HHDT
Grading	8	20.00	0.00	0.00	10.00	6.90	20.00	LD_Mix	HDT_Mix	HHDT
Building Construction	9	801.00	143.00	0.00	10.00	6.90	20.00	LD_Mix	HDT_Mix	HHDT
Paving	6	15.00	0.00	0.00	10.00	6.90	20.00	LD_Mix	HDT_Mix	HHDT
Architectural Coating	1	160.00	0.00	0.00	10.00	6.90	20.00	LD_Mix	HDT_Mix	HHDT

3.1 Mitigation Measures Construction

3.2 Demolition - 2021

Unmitigated Construction On-Site

	ROG	NOx	CO	SO2	Fugitive PM10	Exhaust PM10	PM10 Total	Fugitive PM2.5	Exhaust PM2.5	PM2.5 Total	Bio- CO2	NBio- CO2	Total CO2	CH4	N2O	CO2e
Category	lb/day										lb/day					
Fugitive Dust					3.3074	0.0000	3.3074	0.5008	0.0000	0.5008			0.0000			0.0000
Off-Road	3.1651	31.4407	21.5650	0.0388		1.5513	1.5513		1.4411	1.4411		3,747.9449	3,747.9449	1.0549		3,774.3174
Total	3.1651	31.4407	21.5650	0.0388	3.3074	1.5513	4.8588	0.5008	1.4411	1.9419		3,747.9449	3,747.9449	1.0549		3,774.3174

Village South Specific Plan (Proposed) - Los Angeles-South Coast County, Summer

3.2 Demolition - 2021

Unmitigated Construction Off-Site

	ROG	NOx	CO	SO2	Fugitive PM10	Exhaust PM10	PM10 Total	Fugitive PM2.5	Exhaust PM2.5	PM2.5 Total	Bio- CO2	NBio- CO2	Total CO2	CH4	N2O	CO2e
Category	lb/day										lb/day					
Hauling	0.1273	4.0952	0.9602	0.0119	0.2669	0.0126	0.2795	0.0732	0.0120	0.0852		1,292.2413	1,292.2413	0.0877		1,294.4337
Vendor	0.0000	0.0000	0.0000	0.0000	0.0000	0.0000	0.0000	0.0000	0.0000	0.0000		0.0000	0.0000	0.0000		0.0000
Worker	0.0487	0.0313	0.4282	1.1800e-003	0.1141	9.5000e-004	0.1151	0.0303	8.8000e-004	0.0311		117.2799	117.2799	3.5200e-003		117.3678
Total	0.1760	4.1265	1.3884	0.0131	0.3810	0.0135	0.3946	0.1034	0.0129	0.1163		1,409.5212	1,409.5212	0.0912		1,411.8015

Mitigated Construction On-Site

	ROG	NOx	CO	SO2	Fugitive PM10	Exhaust PM10	PM10 Total	Fugitive PM2.5	Exhaust PM2.5	PM2.5 Total	Bio- CO2	NBio- CO2	Total CO2	CH4	N2O	CO2e
Category	lb/day										lb/day					
Fugitive Dust					3.3074	0.0000	3.3074	0.5008	0.0000	0.5008			0.0000			0.0000
Off-Road	3.1651	31.4407	21.5650	0.0388		1.5513	1.5513		1.4411	1.4411	0.0000	3,747.9449	3,747.9449	1.0549		3,774.3174
Total	3.1651	31.4407	21.5650	0.0388	3.3074	1.5513	4.8588	0.5008	1.4411	1.9419	0.0000	3,747.9449	3,747.9449	1.0549		3,774.3174

Village South Specific Plan (Proposed) - Los Angeles-South Coast County, Summer

3.2 Demolition - 2021

Mitigated Construction Off-Site

	ROG	NOx	CO	SO2	Fugitive PM10	Exhaust PM10	PM10 Total	Fugitive PM2.5	Exhaust PM2.5	PM2.5 Total	Bio- CO2	NBio- CO2	Total CO2	CH4	N2O	CO2e
Category	lb/day										lb/day					
Hauling	0.1273	4.0952	0.9602	0.0119	0.2669	0.0126	0.2795	0.0732	0.0120	0.0852		1,292.2413	1,292.2413	0.0877		1,294.4337
Vendor	0.0000	0.0000	0.0000	0.0000	0.0000	0.0000	0.0000	0.0000	0.0000	0.0000		0.0000	0.0000	0.0000		0.0000
Worker	0.0487	0.0313	0.4282	1.1800e-003	0.1141	9.5000e-004	0.1151	0.0303	8.8000e-004	0.0311		117.2799	117.2799	3.5200e-003		117.3678
Total	0.1760	4.1265	1.3884	0.0131	0.3810	0.0135	0.3946	0.1034	0.0129	0.1163		1,409.5212	1,409.5212	0.0912		1,411.8015

3.3 Site Preparation - 2021

Unmitigated Construction On-Site

	ROG	NOx	CO	SO2	Fugitive PM10	Exhaust PM10	PM10 Total	Fugitive PM2.5	Exhaust PM2.5	PM2.5 Total	Bio- CO2	NBio- CO2	Total CO2	CH4	N2O	CO2e
Category	lb/day										lb/day					
Fugitive Dust					18.0663	0.0000	18.0663	9.9307	0.0000	9.9307			0.0000			0.0000
Off-Road	3.8882	40.4971	21.1543	0.0380		2.0445	2.0445		1.8809	1.8809		3,685.6569	3,685.6569	1.1920		3,715.4573
Total	3.8882	40.4971	21.1543	0.0380	18.0663	2.0445	20.1107	9.9307	1.8809	11.8116		3,685.6569	3,685.6569	1.1920		3,715.4573

Village South Specific Plan (Proposed) - Los Angeles-South Coast County, Summer

3.3 Site Preparation - 2021

Unmitigated Construction Off-Site

	ROG	NOx	CO	SO2	Fugitive PM10	Exhaust PM10	PM10 Total	Fugitive PM2.5	Exhaust PM2.5	PM2.5 Total	Bio- CO2	NBio- CO2	Total CO2	CH4	N2O	CO2e
Category	lb/day										lb/day					
Hauling	0.0000	0.0000	0.0000	0.0000	0.0000	0.0000	0.0000	0.0000	0.0000	0.0000		0.0000	0.0000	0.0000		0.0000
Vendor	0.0000	0.0000	0.0000	0.0000	0.0000	0.0000	0.0000	0.0000	0.0000	0.0000		0.0000	0.0000	0.0000		0.0000
Worker	0.0584	0.0375	0.5139	1.4100e-003	0.1369	1.1400e-003	0.1381	0.0363	1.0500e-003	0.0374		140.7359	140.7359	4.2200e-003		140.8414
Total	0.0584	0.0375	0.5139	1.4100e-003	0.1369	1.1400e-003	0.1381	0.0363	1.0500e-003	0.0374		140.7359	140.7359	4.2200e-003		140.8414

Mitigated Construction On-Site

	ROG	NOx	CO	SO2	Fugitive PM10	Exhaust PM10	PM10 Total	Fugitive PM2.5	Exhaust PM2.5	PM2.5 Total	Bio- CO2	NBio- CO2	Total CO2	CH4	N2O	CO2e
Category	lb/day										lb/day					
Fugitive Dust					18.0663	0.0000	18.0663	9.9307	0.0000	9.9307			0.0000			0.0000
Off-Road	3.8882	40.4971	21.1543	0.0380		2.0445	2.0445		1.8809	1.8809	0.0000	3,685.6569	3,685.6569	1.1920		3,715.4573
Total	3.8882	40.4971	21.1543	0.0380	18.0663	2.0445	20.1107	9.9307	1.8809	11.8116	0.0000	3,685.6569	3,685.6569	1.1920		3,715.4573

Village South Specific Plan (Proposed) - Los Angeles-South Coast County, Summer

3.3 Site Preparation - 2021

Mitigated Construction Off-Site

	ROG	NOx	CO	SO2	Fugitive PM10	Exhaust PM10	PM10 Total	Fugitive PM2.5	Exhaust PM2.5	PM2.5 Total	Bio- CO2	NBio- CO2	Total CO2	CH4	N2O	CO2e
Category	lb/day										lb/day					
Hauling	0.0000	0.0000	0.0000	0.0000	0.0000	0.0000	0.0000	0.0000	0.0000	0.0000		0.0000	0.0000	0.0000		0.0000
Vendor	0.0000	0.0000	0.0000	0.0000	0.0000	0.0000	0.0000	0.0000	0.0000	0.0000		0.0000	0.0000	0.0000		0.0000
Worker	0.0584	0.0375	0.5139	1.4100e-003	0.1369	1.1400e-003	0.1381	0.0363	1.0500e-003	0.0374		140.7359	140.7359	4.2200e-003		140.8414
Total	0.0584	0.0375	0.5139	1.4100e-003	0.1369	1.1400e-003	0.1381	0.0363	1.0500e-003	0.0374		140.7359	140.7359	4.2200e-003		140.8414

3.4 Grading - 2021

Unmitigated Construction On-Site

	ROG	NOx	CO	SO2	Fugitive PM10	Exhaust PM10	PM10 Total	Fugitive PM2.5	Exhaust PM2.5	PM2.5 Total	Bio- CO2	NBio- CO2	Total CO2	CH4	N2O	CO2e
Category	lb/day										lb/day					
Fugitive Dust					8.6733	0.0000	8.6733	3.5965	0.0000	3.5965			0.0000			0.0000
Off-Road	4.1912	46.3998	30.8785	0.0620		1.9853	1.9853		1.8265	1.8265		6,007.0434	6,007.0434	1.9428		6,055.6134
Total	4.1912	46.3998	30.8785	0.0620	8.6733	1.9853	10.6587	3.5965	1.8265	5.4230		6,007.0434	6,007.0434	1.9428		6,055.6134

Village South Specific Plan (Proposed) - Los Angeles-South Coast County, Summer

3.4 Grading - 2021

Unmitigated Construction Off-Site

	ROG	NOx	CO	SO2	Fugitive PM10	Exhaust PM10	PM10 Total	Fugitive PM2.5	Exhaust PM2.5	PM2.5 Total	Bio- CO2	NBio- CO2	Total CO2	CH4	N2O	CO2e
Category	lb/day										lb/day					
Hauling	0.0000	0.0000	0.0000	0.0000	0.0000	0.0000	0.0000	0.0000	0.0000	0.0000		0.0000	0.0000	0.0000		0.0000
Vendor	0.0000	0.0000	0.0000	0.0000	0.0000	0.0000	0.0000	0.0000	0.0000	0.0000		0.0000	0.0000	0.0000		0.0000
Worker	0.0649	0.0417	0.5710	1.5700e-003	0.1521	1.2700e-003	0.1534	0.0404	1.1700e-003	0.0415		156.3732	156.3732	4.6900e-003		156.4904
Total	0.0649	0.0417	0.5710	1.5700e-003	0.1521	1.2700e-003	0.1534	0.0404	1.1700e-003	0.0415		156.3732	156.3732	4.6900e-003		156.4904

Mitigated Construction On-Site

	ROG	NOx	CO	SO2	Fugitive PM10	Exhaust PM10	PM10 Total	Fugitive PM2.5	Exhaust PM2.5	PM2.5 Total	Bio- CO2	NBio- CO2	Total CO2	CH4	N2O	CO2e
Category	lb/day										lb/day					
Fugitive Dust					8.6733	0.0000	8.6733	3.5965	0.0000	3.5965			0.0000			0.0000
Off-Road	4.1912	46.3998	30.8785	0.0620		1.9853	1.9853		1.8265	1.8265	0.0000	6,007.0434	6,007.0434	1.9428		6,055.6134
Total	4.1912	46.3998	30.8785	0.0620	8.6733	1.9853	10.6587	3.5965	1.8265	5.4230	0.0000	6,007.0434	6,007.0434	1.9428		6,055.6134

Village South Specific Plan (Proposed) - Los Angeles-South Coast County, Summer

3.4 Grading - 2021

Mitigated Construction Off-Site

	ROG	NOx	CO	SO2	Fugitive PM10	Exhaust PM10	PM10 Total	Fugitive PM2.5	Exhaust PM2.5	PM2.5 Total	Bio- CO2	NBio- CO2	Total CO2	CH4	N2O	CO2e
Category	lb/day										lb/day					
Hauling	0.0000	0.0000	0.0000	0.0000	0.0000	0.0000	0.0000	0.0000	0.0000	0.0000		0.0000	0.0000	0.0000		0.0000
Vendor	0.0000	0.0000	0.0000	0.0000	0.0000	0.0000	0.0000	0.0000	0.0000	0.0000		0.0000	0.0000	0.0000		0.0000
Worker	0.0649	0.0417	0.5710	1.5700e-003	0.1521	1.2700e-003	0.1534	0.0404	1.1700e-003	0.0415		156.3732	156.3732	4.6900e-003		156.4904
Total	0.0649	0.0417	0.5710	1.5700e-003	0.1521	1.2700e-003	0.1534	0.0404	1.1700e-003	0.0415		156.3732	156.3732	4.6900e-003		156.4904

3.4 Grading - 2022

Unmitigated Construction On-Site

	ROG	NOx	CO	SO2	Fugitive PM10	Exhaust PM10	PM10 Total	Fugitive PM2.5	Exhaust PM2.5	PM2.5 Total	Bio- CO2	NBio- CO2	Total CO2	CH4	N2O	CO2e
Category	lb/day										lb/day					
Fugitive Dust					8.6733	0.0000	8.6733	3.5965	0.0000	3.5965			0.0000			0.0000
Off-Road	3.6248	38.8435	29.0415	0.0621		1.6349	1.6349		1.5041	1.5041		6,011.4105	6,011.4105	1.9442		6,060.0158
Total	3.6248	38.8435	29.0415	0.0621	8.6733	1.6349	10.3082	3.5965	1.5041	5.1006		6,011.4105	6,011.4105	1.9442		6,060.0158

Village South Specific Plan (Proposed) - Los Angeles-South Coast County, Summer

3.4 Grading - 2022

Unmitigated Construction Off-Site

	ROG	NOx	CO	SO2	Fugitive PM10	Exhaust PM10	PM10 Total	Fugitive PM2.5	Exhaust PM2.5	PM2.5 Total	Bio- CO2	NBio- CO2	Total CO2	CH4	N2O	CO2e
Category	lb/day										lb/day					
Hauling	0.0000	0.0000	0.0000	0.0000	0.0000	0.0000	0.0000	0.0000	0.0000	0.0000		0.0000	0.0000	0.0000		0.0000
Vendor	0.0000	0.0000	0.0000	0.0000	0.0000	0.0000	0.0000	0.0000	0.0000	0.0000		0.0000	0.0000	0.0000		0.0000
Worker	0.0607	0.0376	0.5263	1.5100e-003	0.1521	1.2300e-003	0.1534	0.0404	1.1300e-003	0.0415		150.8754	150.8754	4.2400e-003		150.9813
Total	0.0607	0.0376	0.5263	1.5100e-003	0.1521	1.2300e-003	0.1534	0.0404	1.1300e-003	0.0415		150.8754	150.8754	4.2400e-003		150.9813

Mitigated Construction On-Site

	ROG	NOx	CO	SO2	Fugitive PM10	Exhaust PM10	PM10 Total	Fugitive PM2.5	Exhaust PM2.5	PM2.5 Total	Bio- CO2	NBio- CO2	Total CO2	CH4	N2O	CO2e
Category	lb/day										lb/day					
Fugitive Dust					8.6733	0.0000	8.6733	3.5965	0.0000	3.5965			0.0000			0.0000
Off-Road	3.6248	38.8435	29.0415	0.0621		1.6349	1.6349		1.5041	1.5041	0.0000	6,011.4105	6,011.4105	1.9442		6,060.0158
Total	3.6248	38.8435	29.0415	0.0621	8.6733	1.6349	10.3082	3.5965	1.5041	5.1006	0.0000	6,011.4105	6,011.4105	1.9442		6,060.0158

Village South Specific Plan (Proposed) - Los Angeles-South Coast County, Summer

3.4 Grading - 2022

Mitigated Construction Off-Site

	ROG	NOx	CO	SO2	Fugitive PM10	Exhaust PM10	PM10 Total	Fugitive PM2.5	Exhaust PM2.5	PM2.5 Total	Bio- CO2	NBio- CO2	Total CO2	CH4	N2O	CO2e
Category	lb/day										lb/day					
Hauling	0.0000	0.0000	0.0000	0.0000	0.0000	0.0000	0.0000	0.0000	0.0000	0.0000		0.0000	0.0000	0.0000		0.0000
Vendor	0.0000	0.0000	0.0000	0.0000	0.0000	0.0000	0.0000	0.0000	0.0000	0.0000		0.0000	0.0000	0.0000		0.0000
Worker	0.0607	0.0376	0.5263	1.5100e-003	0.1521	1.2300e-003	0.1534	0.0404	1.1300e-003	0.0415		150.8754	150.8754	4.2400e-003		150.9813
Total	0.0607	0.0376	0.5263	1.5100e-003	0.1521	1.2300e-003	0.1534	0.0404	1.1300e-003	0.0415		150.8754	150.8754	4.2400e-003		150.9813

3.5 Building Construction - 2022

Unmitigated Construction On-Site

	ROG	NOx	CO	SO2	Fugitive PM10	Exhaust PM10	PM10 Total	Fugitive PM2.5	Exhaust PM2.5	PM2.5 Total	Bio- CO2	NBio- CO2	Total CO2	CH4	N2O	CO2e
Category	lb/day										lb/day					
Off-Road	1.7062	15.6156	16.3634	0.0269		0.8090	0.8090		0.7612	0.7612		2,554.3336	2,554.3336	0.6120		2,569.6322
Total	1.7062	15.6156	16.3634	0.0269		0.8090	0.8090		0.7612	0.7612		2,554.3336	2,554.3336	0.6120		2,569.6322

Village South Specific Plan (Proposed) - Los Angeles-South Coast County, Summer

3.5 Building Construction - 2022

Unmitigated Construction Off-Site

	ROG	NOx	CO	SO2	Fugitive PM10	Exhaust PM10	PM10 Total	Fugitive PM2.5	Exhaust PM2.5	PM2.5 Total	Bio- CO2	NBio- CO2	Total CO2	CH4	N2O	CO2e
Category	lb/day										lb/day					
Hauling	0.0000	0.0000	0.0000	0.0000	0.0000	0.0000	0.0000	0.0000	0.0000	0.0000		0.0000	0.0000	0.0000		0.0000
Vendor	0.4079	13.2032	3.4341	0.0364	0.9155	0.0248	0.9404	0.2636	0.0237	0.2873		3,896.548 2	3,896.548 2	0.2236		3,902.138 4
Worker	2.4299	1.5074	21.0801	0.0607	6.0932	0.0493	6.1425	1.6163	0.0454	1.6617		6,042.558 5	6,042.558 5	0.1697		6,046.800 0
Total	2.8378	14.7106	24.5142	0.0971	7.0087	0.0741	7.0828	1.8799	0.0691	1.9490		9,939.106 7	9,939.106 7	0.3933		9,948.938 4

Mitigated Construction On-Site

	ROG	NOx	CO	SO2	Fugitive PM10	Exhaust PM10	PM10 Total	Fugitive PM2.5	Exhaust PM2.5	PM2.5 Total	Bio- CO2	NBio- CO2	Total CO2	CH4	N2O	CO2e
Category	lb/day										lb/day					
Off-Road	1.7062	15.6156	16.3634	0.0269		0.8090	0.8090		0.7612	0.7612	0.0000	2,554.333 6	2,554.333 6	0.6120		2,569.632 2
Total	1.7062	15.6156	16.3634	0.0269		0.8090	0.8090		0.7612	0.7612	0.0000	2,554.333 6	2,554.333 6	0.6120		2,569.632 2

Village South Specific Plan (Proposed) - Los Angeles-South Coast County, Summer

3.5 Building Construction - 2022

Mitigated Construction Off-Site

	ROG	NOx	CO	SO2	Fugitive PM10	Exhaust PM10	PM10 Total	Fugitive PM2.5	Exhaust PM2.5	PM2.5 Total	Bio- CO2	NBio- CO2	Total CO2	CH4	N2O	CO2e
Category	lb/day										lb/day					
Hauling	0.0000	0.0000	0.0000	0.0000	0.0000	0.0000	0.0000	0.0000	0.0000	0.0000		0.0000	0.0000	0.0000		0.0000
Vendor	0.4079	13.2032	3.4341	0.0364	0.9155	0.0248	0.9404	0.2636	0.0237	0.2873		3,896.548 2	3,896.548 2	0.2236		3,902.138 4
Worker	2.4299	1.5074	21.0801	0.0607	6.0932	0.0493	6.1425	1.6163	0.0454	1.6617		6,042.558 5	6,042.558 5	0.1697		6,046.800 0
Total	2.8378	14.7106	24.5142	0.0971	7.0087	0.0741	7.0828	1.8799	0.0691	1.9490		9,939.106 7	9,939.106 7	0.3933		9,948.938 4

3.5 Building Construction - 2023

Unmitigated Construction On-Site

	ROG	NOx	CO	SO2	Fugitive PM10	Exhaust PM10	PM10 Total	Fugitive PM2.5	Exhaust PM2.5	PM2.5 Total	Bio- CO2	NBio- CO2	Total CO2	CH4	N2O	CO2e
Category	lb/day										lb/day					
Off-Road	1.5728	14.3849	16.2440	0.0269		0.6997	0.6997		0.6584	0.6584		2,555.209 9	2,555.209 9	0.6079		2,570.406 1
Total	1.5728	14.3849	16.2440	0.0269		0.6997	0.6997		0.6584	0.6584		2,555.209 9	2,555.209 9	0.6079		2,570.406 1

Village South Specific Plan (Proposed) - Los Angeles-South Coast County, Summer

3.5 Building Construction - 2023

Unmitigated Construction Off-Site

	ROG	NOx	CO	SO2	Fugitive PM10	Exhaust PM10	PM10 Total	Fugitive PM2.5	Exhaust PM2.5	PM2.5 Total	Bio- CO2	NBio- CO2	Total CO2	CH4	N2O	CO2e
Category	lb/day										lb/day					
Hauling	0.0000	0.0000	0.0000	0.0000	0.0000	0.0000	0.0000	0.0000	0.0000	0.0000		0.0000	0.0000	0.0000		0.0000
Vendor	0.3027	10.0181	3.1014	0.0352	0.9156	0.0116	0.9271	0.2636	0.0111	0.2747		3,773.876 2	3,773.876 2	0.1982		3,778.830 0
Worker	2.2780	1.3628	19.4002	0.0584	6.0932	0.0479	6.1411	1.6163	0.0441	1.6604		5,821.402 8	5,821.402 8	0.1529		5,825.225 4
Total	2.5807	11.3809	22.5017	0.0936	7.0088	0.0595	7.0682	1.8799	0.0552	1.9350		9,595.279 0	9,595.279 0	0.3511		9,604.055 4

Mitigated Construction On-Site

	ROG	NOx	CO	SO2	Fugitive PM10	Exhaust PM10	PM10 Total	Fugitive PM2.5	Exhaust PM2.5	PM2.5 Total	Bio- CO2	NBio- CO2	Total CO2	CH4	N2O	CO2e
Category	lb/day										lb/day					
Off-Road	1.5728	14.3849	16.2440	0.0269		0.6997	0.6997		0.6584	0.6584	0.0000	2,555.209 9	2,555.209 9	0.6079		2,570.406 1
Total	1.5728	14.3849	16.2440	0.0269		0.6997	0.6997		0.6584	0.6584	0.0000	2,555.209 9	2,555.209 9	0.6079		2,570.406 1

Village South Specific Plan (Proposed) - Los Angeles-South Coast County, Summer

3.5 Building Construction - 2023

Mitigated Construction Off-Site

	ROG	NOx	CO	SO2	Fugitive PM10	Exhaust PM10	PM10 Total	Fugitive PM2.5	Exhaust PM2.5	PM2.5 Total	Bio- CO2	NBio- CO2	Total CO2	CH4	N2O	CO2e
Category	lb/day										lb/day					
Hauling	0.0000	0.0000	0.0000	0.0000	0.0000	0.0000	0.0000	0.0000	0.0000	0.0000		0.0000	0.0000	0.0000		0.0000
Vendor	0.3027	10.0181	3.1014	0.0352	0.9156	0.0116	0.9271	0.2636	0.0111	0.2747		3,773.876 2	3,773.876 2	0.1982		3,778.830 0
Worker	2.2780	1.3628	19.4002	0.0584	6.0932	0.0479	6.1411	1.6163	0.0441	1.6604		5,821.402 8	5,821.402 8	0.1529		5,825.225 4
Total	2.5807	11.3809	22.5017	0.0936	7.0088	0.0595	7.0682	1.8799	0.0552	1.9350		9,595.279 0	9,595.279 0	0.3511		9,604.055 4

3.6 Paving - 2023

Unmitigated Construction On-Site

	ROG	NOx	CO	SO2	Fugitive PM10	Exhaust PM10	PM10 Total	Fugitive PM2.5	Exhaust PM2.5	PM2.5 Total	Bio- CO2	NBio- CO2	Total CO2	CH4	N2O	CO2e
Category	lb/day										lb/day					
Off-Road	1.0327	10.1917	14.5842	0.0228		0.5102	0.5102		0.4694	0.4694		2,207.584 1	2,207.584 1	0.7140		2,225.433 6
Paving	0.0000					0.0000	0.0000		0.0000	0.0000			0.0000			0.0000
Total	1.0327	10.1917	14.5842	0.0228		0.5102	0.5102		0.4694	0.4694		2,207.584 1	2,207.584 1	0.7140		2,225.433 6

Village South Specific Plan (Proposed) - Los Angeles-South Coast County, Summer

3.6 Paving - 2023

Unmitigated Construction Off-Site

	ROG	NOx	CO	SO2	Fugitive PM10	Exhaust PM10	PM10 Total	Fugitive PM2.5	Exhaust PM2.5	PM2.5 Total	Bio- CO2	NBio- CO2	Total CO2	CH4	N2O	CO2e
Category	lb/day										lb/day					
Hauling	0.0000	0.0000	0.0000	0.0000	0.0000	0.0000	0.0000	0.0000	0.0000	0.0000		0.0000	0.0000	0.0000		0.0000
Vendor	0.0000	0.0000	0.0000	0.0000	0.0000	0.0000	0.0000	0.0000	0.0000	0.0000		0.0000	0.0000	0.0000		0.0000
Worker	0.0427	0.0255	0.3633	1.0900e-003	0.1141	9.0000e-004	0.1150	0.0303	8.3000e-004	0.0311		109.0150	109.0150	2.8600e-003		109.0866
Total	0.0427	0.0255	0.3633	1.0900e-003	0.1141	9.0000e-004	0.1150	0.0303	8.3000e-004	0.0311		109.0150	109.0150	2.8600e-003		109.0866

Mitigated Construction On-Site

	ROG	NOx	CO	SO2	Fugitive PM10	Exhaust PM10	PM10 Total	Fugitive PM2.5	Exhaust PM2.5	PM2.5 Total	Bio- CO2	NBio- CO2	Total CO2	CH4	N2O	CO2e
Category	lb/day										lb/day					
Off-Road	1.0327	10.1917	14.5842	0.0228		0.5102	0.5102		0.4694	0.4694	0.0000	2,207.5841	2,207.5841	0.7140		2,225.4336
Paving	0.0000					0.0000	0.0000		0.0000	0.0000			0.0000			0.0000
Total	1.0327	10.1917	14.5842	0.0228		0.5102	0.5102		0.4694	0.4694	0.0000	2,207.5841	2,207.5841	0.7140		2,225.4336

Village South Specific Plan (Proposed) - Los Angeles-South Coast County, Summer

3.6 Paving - 2023

Mitigated Construction Off-Site

	ROG	NOx	CO	SO2	Fugitive PM10	Exhaust PM10	PM10 Total	Fugitive PM2.5	Exhaust PM2.5	PM2.5 Total	Bio- CO2	NBio- CO2	Total CO2	CH4	N2O	CO2e
Category	lb/day										lb/day					
Hauling	0.0000	0.0000	0.0000	0.0000	0.0000	0.0000	0.0000	0.0000	0.0000	0.0000		0.0000	0.0000	0.0000		0.0000
Vendor	0.0000	0.0000	0.0000	0.0000	0.0000	0.0000	0.0000	0.0000	0.0000	0.0000		0.0000	0.0000	0.0000		0.0000
Worker	0.0427	0.0255	0.3633	1.0900e-003	0.1141	9.0000e-004	0.1150	0.0303	8.3000e-004	0.0311		109.0150	109.0150	2.8600e-003		109.0866
Total	0.0427	0.0255	0.3633	1.0900e-003	0.1141	9.0000e-004	0.1150	0.0303	8.3000e-004	0.0311		109.0150	109.0150	2.8600e-003		109.0866

3.6 Paving - 2024

Unmitigated Construction On-Site

	ROG	NOx	CO	SO2	Fugitive PM10	Exhaust PM10	PM10 Total	Fugitive PM2.5	Exhaust PM2.5	PM2.5 Total	Bio- CO2	NBio- CO2	Total CO2	CH4	N2O	CO2e
Category	lb/day										lb/day					
Off-Road	0.9882	9.5246	14.6258	0.0228		0.4685	0.4685		0.4310	0.4310		2,207.5472	2,207.5472	0.7140		2,225.3963
Paving	0.0000					0.0000	0.0000		0.0000	0.0000			0.0000			0.0000
Total	0.9882	9.5246	14.6258	0.0228		0.4685	0.4685		0.4310	0.4310		2,207.5472	2,207.5472	0.7140		2,225.3963

Village South Specific Plan (Proposed) - Los Angeles-South Coast County, Summer

3.6 Paving - 2024

Unmitigated Construction Off-Site

	ROG	NOx	CO	SO2	Fugitive PM10	Exhaust PM10	PM10 Total	Fugitive PM2.5	Exhaust PM2.5	PM2.5 Total	Bio- CO2	NBio- CO2	Total CO2	CH4	N2O	CO2e
Category	lb/day										lb/day					
Hauling	0.0000	0.0000	0.0000	0.0000	0.0000	0.0000	0.0000	0.0000	0.0000	0.0000		0.0000	0.0000	0.0000		0.0000
Vendor	0.0000	0.0000	0.0000	0.0000	0.0000	0.0000	0.0000	0.0000	0.0000	0.0000		0.0000	0.0000	0.0000		0.0000
Worker	0.0403	0.0233	0.3384	1.0600e-003	0.1141	8.8000e-004	0.1150	0.0303	8.1000e-004	0.0311		105.6336	105.6336	2.6300e-003		105.6992
Total	0.0403	0.0233	0.3384	1.0600e-003	0.1141	8.8000e-004	0.1150	0.0303	8.1000e-004	0.0311		105.6336	105.6336	2.6300e-003		105.6992

Mitigated Construction On-Site

	ROG	NOx	CO	SO2	Fugitive PM10	Exhaust PM10	PM10 Total	Fugitive PM2.5	Exhaust PM2.5	PM2.5 Total	Bio- CO2	NBio- CO2	Total CO2	CH4	N2O	CO2e
Category	lb/day										lb/day					
Off-Road	0.9882	9.5246	14.6258	0.0228		0.4685	0.4685		0.4310	0.4310	0.0000	2,207.5472	2,207.5472	0.7140		2,225.3963
Paving	0.0000					0.0000	0.0000		0.0000	0.0000			0.0000			0.0000
Total	0.9882	9.5246	14.6258	0.0228		0.4685	0.4685		0.4310	0.4310	0.0000	2,207.5472	2,207.5472	0.7140		2,225.3963

Village South Specific Plan (Proposed) - Los Angeles-South Coast County, Summer

3.6 Paving - 2024

Mitigated Construction Off-Site

	ROG	NOx	CO	SO2	Fugitive PM10	Exhaust PM10	PM10 Total	Fugitive PM2.5	Exhaust PM2.5	PM2.5 Total	Bio- CO2	NBio- CO2	Total CO2	CH4	N2O	CO2e
Category	lb/day										lb/day					
Hauling	0.0000	0.0000	0.0000	0.0000	0.0000	0.0000	0.0000	0.0000	0.0000	0.0000		0.0000	0.0000	0.0000		0.0000
Vendor	0.0000	0.0000	0.0000	0.0000	0.0000	0.0000	0.0000	0.0000	0.0000	0.0000		0.0000	0.0000	0.0000		0.0000
Worker	0.0403	0.0233	0.3384	1.0600e-003	0.1141	8.8000e-004	0.1150	0.0303	8.1000e-004	0.0311		105.6336	105.6336	2.6300e-003		105.6992
Total	0.0403	0.0233	0.3384	1.0600e-003	0.1141	8.8000e-004	0.1150	0.0303	8.1000e-004	0.0311		105.6336	105.6336	2.6300e-003		105.6992

3.7 Architectural Coating - 2024

Unmitigated Construction On-Site

	ROG	NOx	CO	SO2	Fugitive PM10	Exhaust PM10	PM10 Total	Fugitive PM2.5	Exhaust PM2.5	PM2.5 Total	Bio- CO2	NBio- CO2	Total CO2	CH4	N2O	CO2e
Category	lb/day										lb/day					
Archit. Coating	236.4115					0.0000	0.0000		0.0000	0.0000			0.0000			0.0000
Off-Road	0.1808	1.2188	1.8101	2.9700e-003		0.0609	0.0609		0.0609	0.0609		281.4481	281.4481	0.0159		281.8443
Total	236.5923	1.2188	1.8101	2.9700e-003		0.0609	0.0609		0.0609	0.0609		281.4481	281.4481	0.0159		281.8443

Village South Specific Plan (Proposed) - Los Angeles-South Coast County, Summer

3.7 Architectural Coating - 2024

Unmitigated Construction Off-Site

	ROG	NOx	CO	SO2	Fugitive PM10	Exhaust PM10	PM10 Total	Fugitive PM2.5	Exhaust PM2.5	PM2.5 Total	Bio- CO2	NBio- CO2	Total CO2	CH4	N2O	CO2e
Category	lb/day										lb/day					
Hauling	0.0000	0.0000	0.0000	0.0000	0.0000	0.0000	0.0000	0.0000	0.0000	0.0000		0.0000	0.0000	0.0000		0.0000
Vendor	0.0000	0.0000	0.0000	0.0000	0.0000	0.0000	0.0000	0.0000	0.0000	0.0000		0.0000	0.0000	0.0000		0.0000
Worker	0.4296	0.2481	3.6098	0.0113	1.2171	9.4300e-003	1.2266	0.3229	8.6800e-003	0.3315		1,126.7583	1,126.7583	0.0280		1,127.4583
Total	0.4296	0.2481	3.6098	0.0113	1.2171	9.4300e-003	1.2266	0.3229	8.6800e-003	0.3315		1,126.7583	1,126.7583	0.0280		1,127.4583

Mitigated Construction On-Site

	ROG	NOx	CO	SO2	Fugitive PM10	Exhaust PM10	PM10 Total	Fugitive PM2.5	Exhaust PM2.5	PM2.5 Total	Bio- CO2	NBio- CO2	Total CO2	CH4	N2O	CO2e
Category	lb/day										lb/day					
Archit. Coating	236.4115					0.0000	0.0000		0.0000	0.0000			0.0000			0.0000
Off-Road	0.1808	1.2188	1.8101	2.9700e-003		0.0609	0.0609		0.0609	0.0609	0.0000	281.4481	281.4481	0.0159		281.8443
Total	236.5923	1.2188	1.8101	2.9700e-003		0.0609	0.0609		0.0609	0.0609	0.0000	281.4481	281.4481	0.0159		281.8443

Village South Specific Plan (Proposed) - Los Angeles-South Coast County, Summer

3.7 Architectural Coating - 2024

Mitigated Construction Off-Site

	ROG	NOx	CO	SO2	Fugitive PM10	Exhaust PM10	PM10 Total	Fugitive PM2.5	Exhaust PM2.5	PM2.5 Total	Bio- CO2	NBio- CO2	Total CO2	CH4	N2O	CO2e
Category	lb/day										lb/day					
Hauling	0.0000	0.0000	0.0000	0.0000	0.0000	0.0000	0.0000	0.0000	0.0000	0.0000		0.0000	0.0000	0.0000		0.0000
Vendor	0.0000	0.0000	0.0000	0.0000	0.0000	0.0000	0.0000	0.0000	0.0000	0.0000		0.0000	0.0000	0.0000		0.0000
Worker	0.4296	0.2481	3.6098	0.0113	1.2171	9.4300e-003	1.2266	0.3229	8.6800e-003	0.3315		1,126.7583	1,126.7583	0.0280		1,127.4583
Total	0.4296	0.2481	3.6098	0.0113	1.2171	9.4300e-003	1.2266	0.3229	8.6800e-003	0.3315		1,126.7583	1,126.7583	0.0280		1,127.4583

4.0 Operational Detail - Mobile

4.1 Mitigation Measures Mobile

Village South Specific Plan (Proposed) - Los Angeles-South Coast County, Summer

	ROG	NOx	CO	SO2	Fugitive PM10	Exhaust PM10	PM10 Total	Fugitive PM2.5	Exhaust PM2.5	PM2.5 Total	Bio- CO2	NBio- CO2	Total CO2	CH4	N2O	CO2e
Category	lb/day										lb/day					
Mitigated	9.8489	45.4304	114.8495	0.4917	45.9592	0.3360	46.2951	12.2950	0.3119	12.6070		50,306.60 34	50,306.60 34	2.1807		50,361.12 08
Unmitigated	9.8489	45.4304	114.8495	0.4917	45.9592	0.3360	46.2951	12.2950	0.3119	12.6070		50,306.60 34	50,306.60 34	2.1807		50,361.12 08

4.2 Trip Summary Information

Land Use	Average Daily Trip Rate			Unmitigated	Mitigated
	Weekday	Saturday	Sunday	Annual VMT	Annual VMT
Apartments Low Rise	145.75	154.25	154.00	506,227	506,227
Apartments Mid Rise	4,026.75	3,773.25	4075.50	13,660,065	13,660,065
General Office Building	288.45	62.55	31.05	706,812	706,812
High Turnover (Sit Down Restaurant)	2,368.80	2,873.52	2817.72	3,413,937	3,413,937
Hotel	192.00	187.50	160.00	445,703	445,703
Quality Restaurant	501.12	511.92	461.20	707,488	707,488
Regional Shopping Center	528.08	601.44	357.84	1,112,221	1,112,221
Total	8,050.95	8,164.43	8,057.31	20,552,452	20,552,452

4.3 Trip Type Information

Village South Specific Plan (Proposed) - Los Angeles-South Coast County, Summer

Land Use	Miles			Trip %			Trip Purpose %		
	H-W or C-W	H-S or C-C	H-O or C-NW	H-W or C-W	H-S or C-C	H-O or C-NW	Primary	Diverted	Pass-by
Apartments Low Rise	14.70	5.90	8.70	40.20	19.20	40.60	86	11	3
Apartments Mid Rise	14.70	5.90	8.70	40.20	19.20	40.60	86	11	3
General Office Building	16.60	8.40	6.90	33.00	48.00	19.00	77	19	4
High Turnover (Sit Down Restaurant)	16.60	8.40	6.90	8.50	72.50	19.00	37	20	43
Hotel	16.60	8.40	6.90	19.40	61.60	19.00	58	38	4
Quality Restaurant	16.60	8.40	6.90	12.00	69.00	19.00	38	18	44
Regional Shopping Center	16.60	8.40	6.90	16.30	64.70	19.00	54	35	11

4.4 Fleet Mix

Land Use	LDA	LDT1	LDT2	MDV	LHD1	LHD2	MHD	HHD	OBUS	UBUS	MCY	SBUS	MH
Apartments Low Rise	0.543088	0.044216	0.209971	0.116369	0.014033	0.006332	0.021166	0.033577	0.002613	0.001817	0.005285	0.000712	0.000821
Apartments Mid Rise	0.543088	0.044216	0.209971	0.116369	0.014033	0.006332	0.021166	0.033577	0.002613	0.001817	0.005285	0.000712	0.000821
General Office Building	0.543088	0.044216	0.209971	0.116369	0.014033	0.006332	0.021166	0.033577	0.002613	0.001817	0.005285	0.000712	0.000821
High Turnover (Sit Down Restaurant)	0.543088	0.044216	0.209971	0.116369	0.014033	0.006332	0.021166	0.033577	0.002613	0.001817	0.005285	0.000712	0.000821
Hotel	0.543088	0.044216	0.209971	0.116369	0.014033	0.006332	0.021166	0.033577	0.002613	0.001817	0.005285	0.000712	0.000821
Quality Restaurant	0.543088	0.044216	0.209971	0.116369	0.014033	0.006332	0.021166	0.033577	0.002613	0.001817	0.005285	0.000712	0.000821
Regional Shopping Center	0.543088	0.044216	0.209971	0.116369	0.014033	0.006332	0.021166	0.033577	0.002613	0.001817	0.005285	0.000712	0.000821

5.0 Energy Detail

Historical Energy Use: N

5.1 Mitigation Measures Energy

Village South Specific Plan (Proposed) - Los Angeles-South Coast County, Summer

	ROG	NOx	CO	SO2	Fugitive PM10	Exhaust PM10	PM10 Total	Fugitive PM2.5	Exhaust PM2.5	PM2.5 Total	Bio- CO2	NBio- CO2	Total CO2	CH4	N2O	CO2e
Category	lb/day										lb/day					
NaturalGas Mitigated	0.7660	6.7462	4.2573	0.0418		0.5292	0.5292		0.5292	0.5292		8,355.983 2	8,355.983 2	0.1602	0.1532	8,405.638 7
NaturalGas Unmitigated	0.7660	6.7462	4.2573	0.0418		0.5292	0.5292		0.5292	0.5292		8,355.983 2	8,355.983 2	0.1602	0.1532	8,405.638 7

Village South Specific Plan (Proposed) - Los Angeles-South Coast County, Summer

5.2 Energy by Land Use - NaturalGas

Unmitigated

	NaturalGas Use	ROG	NOx	CO	SO2	Fugitive PM10	Exhaust PM10	PM10 Total	Fugitive PM2.5	Exhaust PM2.5	PM2.5 Total	Bio- CO2	NBio- CO2	Total CO2	CH4	N2O	CO2e
Land Use	kBTU/yr	lb/day										lb/day					
Apartments Low Rise	1119.16	0.0121	0.1031	0.0439	6.6000e-004		8.3400e-003	8.3400e-003		8.3400e-003	8.3400e-003		131.6662	131.6662	2.5200e-003	2.4100e-003	132.4486
Apartments Mid Rise	35784.3	0.3859	3.2978	1.4033	0.0211		0.2666	0.2666		0.2666	0.2666		4,209.9164	4,209.9164	0.0807	0.0772	4,234.9339
General Office Building	1283.42	0.0138	0.1258	0.1057	7.5000e-004		9.5600e-003	9.5600e-003		9.5600e-003	9.5600e-003		150.9911	150.9911	2.8900e-003	2.7700e-003	151.8884
High Turnover (Sit Down Restaurant)	22759.9	0.2455	2.2314	1.8743	0.0134		0.1696	0.1696		0.1696	0.1696		2,677.6342	2,677.6342	0.0513	0.0491	2,693.5460
Hotel	4769.72	0.0514	0.4676	0.3928	2.8100e-003		0.0355	0.0355		0.0355	0.0355		561.1436	561.1436	0.0108	0.0103	564.4782
Quality Restaurant	5057.75	0.0545	0.4959	0.4165	2.9800e-003		0.0377	0.0377		0.0377	0.0377		595.0298	595.0298	0.0114	0.0109	598.5658
Regional Shopping Center	251.616	2.7100e-003	0.0247	0.0207	1.5000e-004		1.8700e-003	1.8700e-003		1.8700e-003	1.8700e-003		29.6019	29.6019	5.7000e-004	5.4000e-004	29.7778
Total		0.7660	6.7463	4.2573	0.0418		0.5292	0.5292		0.5292	0.5292		8,355.9832	8,355.9832	0.1602	0.1532	8,405.6387

Village South Specific Plan (Proposed) - Los Angeles-South Coast County, Summer

5.2 Energy by Land Use - NaturalGas

Mitigated

	NaturalGas Use	ROG	NOx	CO	SO2	Fugitive PM10	Exhaust PM10	PM10 Total	Fugitive PM2.5	Exhaust PM2.5	PM2.5 Total	Bio- CO2	NBio- CO2	Total CO2	CH4	N2O	CO2e
Land Use	kBTU/yr	lb/day										lb/day					
Apartments Low Rise	1.11916	0.0121	0.1031	0.0439	6.6000e-004		8.3400e-003	8.3400e-003		8.3400e-003	8.3400e-003		131.6662	131.6662	2.5200e-003	2.4100e-003	132.4486
Apartments Mid Rise	35.7843	0.3859	3.2978	1.4033	0.0211		0.2666	0.2666		0.2666	0.2666		4,209.9164	4,209.9164	0.0807	0.0772	4,234.9339
General Office Building	1.28342	0.0138	0.1258	0.1057	7.5000e-004		9.5600e-003	9.5600e-003		9.5600e-003	9.5600e-003		150.9911	150.9911	2.8900e-003	2.7700e-003	151.8884
High Turnover (Sit Down Restaurant)	22.7599	0.2455	2.2314	1.8743	0.0134		0.1696	0.1696		0.1696	0.1696		2,677.6342	2,677.6342	0.0513	0.0491	2,693.5460
Hotel	4.76972	0.0514	0.4676	0.3928	2.8100e-003		0.0355	0.0355		0.0355	0.0355		561.1436	561.1436	0.0108	0.0103	564.4782
Quality Restaurant	5.05775	0.0545	0.4959	0.4165	2.9800e-003		0.0377	0.0377		0.0377	0.0377		595.0298	595.0298	0.0114	0.0109	598.5658
Regional Shopping Center	0.251616	2.7100e-003	0.0247	0.0207	1.5000e-004		1.8700e-003	1.8700e-003		1.8700e-003	1.8700e-003		29.6019	29.6019	5.7000e-004	5.4000e-004	29.7778
Total		0.7660	6.7463	4.2573	0.0418		0.5292	0.5292		0.5292	0.5292		8,355.9832	8,355.9832	0.1602	0.1532	8,405.6387

6.0 Area Detail

6.1 Mitigation Measures Area

Village South Specific Plan (Proposed) - Los Angeles-South Coast County, Summer

	ROG	NOx	CO	SO2	Fugitive PM10	Exhaust PM10	PM10 Total	Fugitive PM2.5	Exhaust PM2.5	PM2.5 Total	Bio- CO2	NBio- CO2	Total CO2	CH4	N2O	CO2e
Category	lb/day										lb/day					
Mitigated	30.5020	15.0496	88.4430	0.0944		1.5974	1.5974		1.5974	1.5974	0.0000	18,148.5950	18,148.5950	0.4874	0.3300	18,259.1192
Unmitigated	30.5020	15.0496	88.4430	0.0944		1.5974	1.5974		1.5974	1.5974	0.0000	18,148.5950	18,148.5950	0.4874	0.3300	18,259.1192

6.2 Area by SubCategory

Unmitigated

	ROG	NOx	CO	SO2	Fugitive PM10	Exhaust PM10	PM10 Total	Fugitive PM2.5	Exhaust PM2.5	PM2.5 Total	Bio- CO2	NBio- CO2	Total CO2	CH4	N2O	CO2e
SubCategory	lb/day										lb/day					
Architectural Coating	2.2670					0.0000	0.0000		0.0000	0.0000			0.0000			0.0000
Consumer Products	24.1085					0.0000	0.0000		0.0000	0.0000			0.0000			0.0000
Hearth	1.6500	14.1000	6.0000	0.0900		1.1400	1.1400		1.1400	1.1400	0.0000	18,000.0000	18,000.0000	0.3450	0.3300	18,106.9650
Landscaping	2.4766	0.9496	82.4430	4.3600e-003		0.4574	0.4574		0.4574	0.4574		148.5950	148.5950	0.1424		152.1542
Total	30.5020	15.0496	88.4430	0.0944		1.5974	1.5974		1.5974	1.5974	0.0000	18,148.5950	18,148.5950	0.4874	0.3300	18,259.1192

Village South Specific Plan (Proposed) - Los Angeles-South Coast County, Summer

6.2 Area by SubCategory

Mitigated

	ROG	NOx	CO	SO2	Fugitive PM10	Exhaust PM10	PM10 Total	Fugitive PM2.5	Exhaust PM2.5	PM2.5 Total	Bio- CO2	NBio- CO2	Total CO2	CH4	N2O	CO2e
SubCategory	lb/day										lb/day					
Architectural Coating	2.2670					0.0000	0.0000		0.0000	0.0000			0.0000			0.0000
Consumer Products	24.1085					0.0000	0.0000		0.0000	0.0000			0.0000			0.0000
Hearth	1.6500	14.1000	6.0000	0.0900		1.1400	1.1400		1.1400	1.1400	0.0000	18,000.0000	18,000.0000	0.3450	0.3300	18,106.9650
Landscaping	2.4766	0.9496	82.4430	4.3600e-003		0.4574	0.4574		0.4574	0.4574		148.5950	148.5950	0.1424		152.1542
Total	30.5020	15.0496	88.4430	0.0944		1.5974	1.5974		1.5974	1.5974	0.0000	18,148.5950	18,148.5950	0.4874	0.3300	18,259.1192

7.0 Water Detail

7.1 Mitigation Measures Water

8.0 Waste Detail

8.1 Mitigation Measures Waste

9.0 Operational Offroad

Equipment Type	Number	Hours/Day	Days/Year	Horse Power	Load Factor	Fuel Type
----------------	--------	-----------	-----------	-------------	-------------	-----------

10.0 Stationary Equipment

Village South Specific Plan (Proposed) - Los Angeles-South Coast County, Summer

Fire Pumps and Emergency Generators

Equipment Type	Number	Hours/Day	Hours/Year	Horse Power	Load Factor	Fuel Type
----------------	--------	-----------	------------	-------------	-------------	-----------

Boilers

Equipment Type	Number	Heat Input/Day	Heat Input/Year	Boiler Rating	Fuel Type
----------------	--------	----------------	-----------------	---------------	-----------

User Defined Equipment

Equipment Type	Number
----------------	--------

11.0 Vegetation

Village South Specific Plan (Proposed) - Los Angeles-South Coast County, Winter

Village South Specific Plan (Proposed)
Los Angeles-South Coast County, Winter

1.0 Project Characteristics

1.1 Land Usage

Land Uses	Size	Metric	Lot Acreage	Floor Surface Area	Population
General Office Building	45.00	1000sqft	1.03	45,000.00	0
High Turnover (Sit Down Restaurant)	36.00	1000sqft	0.83	36,000.00	0
Hotel	50.00	Room	1.67	72,600.00	0
Quality Restaurant	8.00	1000sqft	0.18	8,000.00	0
Apartments Low Rise	25.00	Dwelling Unit	1.56	25,000.00	72
Apartments Mid Rise	975.00	Dwelling Unit	25.66	975,000.00	2789
Regional Shopping Center	56.00	1000sqft	1.29	56,000.00	0

1.2 Other Project Characteristics

Urbanization	Urban	Wind Speed (m/s)	2.2	Precipitation Freq (Days)	33
Climate Zone	9			Operational Year	2028
Utility Company	Southern California Edison				
CO2 Intensity (lb/MW hr)	702.44	CH4 Intensity (lb/MW hr)	0.029	N2O Intensity (lb/MW hr)	0.006

1.3 User Entered Comments & Non-Default Data

Village South Specific Plan (Proposed) - Los Angeles-South Coast County, Winter

Project Characteristics - Consistent with the DEIR's model.

Land Use - See SWAPE comment regarding residential and retail land uses.

Construction Phase - See SWAPE comment regarding individual construction phase lengths.

Demolition - Consistent with the DEIR's model. See SWAPE comment regarding demolition.

Vehicle Trips - Saturday trips consistent with the DEIR's model. See SWAPE comment regarding weekday and Sunday trips.

Woodstoves - Woodstoves and wood-burning fireplaces consistent with the DEIR's model. See SWAPE comment regarding gas fireplaces.

Energy Use -

Construction Off-road Equipment Mitigation - See SWAPE comment on construction-related mitigation.

Area Mitigation - See SWAPE comment regarding operational mitigation measures.

Water Mitigation - See SWAPE comment regarding operational mitigation measures.

Trips and VMT - Local hire provision

Table Name	Column Name	Default Value	New Value
tblFireplaces	FireplaceWoodMass	1,019.20	0.00
tblFireplaces	FireplaceWoodMass	1,019.20	0.00
tblFireplaces	NumberWood	1.25	0.00
tblFireplaces	NumberWood	48.75	0.00
tblTripsAndVMT	WorkerTripLength	14.70	10.00
tblTripsAndVMT	WorkerTripLength	14.70	10.00
tblTripsAndVMT	WorkerTripLength	14.70	10.00
tblTripsAndVMT	WorkerTripLength	14.70	10.00
tblTripsAndVMT	WorkerTripLength	14.70	10.00
tblTripsAndVMT	WorkerTripLength	14.70	10.00
tblVehicleTrips	ST_TR	7.16	6.17
tblVehicleTrips	ST_TR	6.39	3.87
tblVehicleTrips	ST_TR	2.46	1.39
tblVehicleTrips	ST_TR	158.37	79.82

Village South Specific Plan (Proposed) - Los Angeles-South Coast County, Winter

tblVehicleTrips	ST_TR	8.19	3.75
tblVehicleTrips	ST_TR	94.36	63.99
tblVehicleTrips	ST_TR	49.97	10.74
tblVehicleTrips	SU_TR	6.07	6.16
tblVehicleTrips	SU_TR	5.86	4.18
tblVehicleTrips	SU_TR	1.05	0.69
tblVehicleTrips	SU_TR	131.84	78.27
tblVehicleTrips	SU_TR	5.95	3.20
tblVehicleTrips	SU_TR	72.16	57.65
tblVehicleTrips	SU_TR	25.24	6.39
tblVehicleTrips	WD_TR	6.59	5.83
tblVehicleTrips	WD_TR	6.65	4.13
tblVehicleTrips	WD_TR	11.03	6.41
tblVehicleTrips	WD_TR	127.15	65.80
tblVehicleTrips	WD_TR	8.17	3.84
tblVehicleTrips	WD_TR	89.95	62.64
tblVehicleTrips	WD_TR	42.70	9.43
tblWoodstoves	NumberCatalytic	1.25	0.00
tblWoodstoves	NumberCatalytic	48.75	0.00
tblWoodstoves	NumberNoncatalytic	1.25	0.00
tblWoodstoves	NumberNoncatalytic	48.75	0.00
tblWoodstoves	WoodstoveDayYear	25.00	0.00
tblWoodstoves	WoodstoveDayYear	25.00	0.00
tblWoodstoves	WoodstoveWoodMass	999.60	0.00
tblWoodstoves	WoodstoveWoodMass	999.60	0.00

2.0 Emissions Summary

Village South Specific Plan (Proposed) - Los Angeles-South Coast County, Winter

2.1 Overall Construction (Maximum Daily Emission)

Unmitigated Construction

	ROG	NOx	CO	SO2	Fugitive PM10	Exhaust PM10	PM10 Total	Fugitive PM2.5	Exhaust PM2.5	PM2.5 Total	Bio- CO2	NBio- CO2	Total CO2	CH4	N2O	CO2e
Year	lb/day										lb/day					
2021	4.2621	46.4460	31.4068	0.0635	18.2032	2.0456	20.2488	9.9670	1.8820	11.8490	0.0000	6,154.3377	6,154.3377	1.9472	0.0000	6,203.0186
2022	4.7966	38.8851	39.6338	0.1195	8.8255	1.6361	10.4616	3.6369	1.5052	5.1421	0.0000	12,035.3440	12,035.3440	1.9482	0.0000	12,060.6013
2023	4.3939	25.8648	37.5031	0.1162	7.0088	0.7598	7.7685	1.8799	0.7142	2.5940	0.0000	11,710.4080	11,710.4080	0.9617	0.0000	11,734.4497
2024	237.0656	9.5503	14.9372	0.0238	1.2171	0.4694	1.2875	0.3229	0.4319	0.4621	0.0000	2,307.0517	2,307.0517	0.7164	0.0000	2,324.9627
Maximum	237.0656	46.4460	39.6338	0.1195	18.2032	2.0456	20.2488	9.9670	1.8820	11.8490	0.0000	12,035.3440	12,035.3440	1.9482	0.0000	12,060.6013

Village South Specific Plan (Proposed) - Los Angeles-South Coast County, Winter

2.2 Overall Operational

Unmitigated Operational

	ROG	NOx	CO	SO2	Fugitive PM10	Exhaust PM10	PM10 Total	Fugitive PM2.5	Exhaust PM2.5	PM2.5 Total	Bio- CO2	NBio- CO2	Total CO2	CH4	N2O	CO2e
Category	lb/day										lb/day					
Area	30.5020	15.0496	88.4430	0.0944		1.5974	1.5974		1.5974	1.5974	0.0000	18,148.5950	18,148.5950	0.4874	0.3300	18,259.1192
Energy	0.7660	6.7462	4.2573	0.0418		0.5292	0.5292		0.5292	0.5292		8,355.9832	8,355.9832	0.1602	0.1532	8,405.6387
Mobile	9.5233	45.9914	110.0422	0.4681	45.9592	0.3373	46.2965	12.2950	0.3132	12.6083		47,917.8005	47,917.8005	2.1953		47,972.6839
Total	40.7912	67.7872	202.7424	0.6043	45.9592	2.4640	48.4231	12.2950	2.4399	14.7349	0.0000	74,422.3787	74,422.3787	2.8429	0.4832	74,637.4417

Mitigated Operational

	ROG	NOx	CO	SO2	Fugitive PM10	Exhaust PM10	PM10 Total	Fugitive PM2.5	Exhaust PM2.5	PM2.5 Total	Bio- CO2	NBio- CO2	Total CO2	CH4	N2O	CO2e
Category	lb/day										lb/day					
Area	30.5020	15.0496	88.4430	0.0944		1.5974	1.5974		1.5974	1.5974	0.0000	18,148.5950	18,148.5950	0.4874	0.3300	18,259.1192
Energy	0.7660	6.7462	4.2573	0.0418		0.5292	0.5292		0.5292	0.5292		8,355.9832	8,355.9832	0.1602	0.1532	8,405.6387
Mobile	9.5233	45.9914	110.0422	0.4681	45.9592	0.3373	46.2965	12.2950	0.3132	12.6083		47,917.8005	47,917.8005	2.1953		47,972.6839
Total	40.7912	67.7872	202.7424	0.6043	45.9592	2.4640	48.4231	12.2950	2.4399	14.7349	0.0000	74,422.3787	74,422.3787	2.8429	0.4832	74,637.4417

Village South Specific Plan (Proposed) - Los Angeles-South Coast County, Winter

	ROG	NOx	CO	SO2	Fugitive PM10	Exhaust PM10	PM10 Total	Fugitive PM2.5	Exhaust PM2.5	PM2.5 Total	Bio- CO2	NBio-CO2	Total CO2	CH4	N2O	CO2e
Percent Reduction	0.00	0.00	0.00	0.00	0.00	0.00	0.00	0.00	0.00	0.00	0.00	0.00	0.00	0.00	0.00	0.00

3.0 Construction Detail

Construction Phase

Phase Number	Phase Name	Phase Type	Start Date	End Date	Num Days Week	Num Days	Phase Description
1	Demolition	Demolition	9/1/2021	10/12/2021	5	30	
2	Site Preparation	Site Preparation	10/13/2021	11/9/2021	5	20	
3	Grading	Grading	11/10/2021	1/11/2022	5	45	
4	Building Construction	Building Construction	1/12/2022	12/12/2023	5	500	
5	Paving	Paving	12/13/2023	1/30/2024	5	35	
6	Architectural Coating	Architectural Coating	1/31/2024	3/19/2024	5	35	

Acres of Grading (Site Preparation Phase): 0

Acres of Grading (Grading Phase): 112.5

Acres of Paving: 0

Residential Indoor: 2,025,000; Residential Outdoor: 675,000; Non-Residential Indoor: 326,400; Non-Residential Outdoor: 108,800; Striped Parking Area: 0 (Architectural Coating – sqft)

OffRoad Equipment

Village South Specific Plan (Proposed) - Los Angeles-South Coast County, Winter

Phase Name	Offroad Equipment Type	Amount	Usage Hours	Horse Power	Load Factor
Demolition	Concrete/Industrial Saws	1	8.00	81	0.73
Demolition	Excavators	3	8.00	158	0.38
Demolition	Rubber Tired Dozers	2	8.00	247	0.40
Site Preparation	Rubber Tired Dozers	3	8.00	247	0.40
Site Preparation	Tractors/Loaders/Backhoes	4	8.00	97	0.37
Grading	Excavators	2	8.00	158	0.38
Grading	Graders	1	8.00	187	0.41
Grading	Rubber Tired Dozers	1	8.00	247	0.40
Grading	Scrapers	2	8.00	367	0.48
Grading	Tractors/Loaders/Backhoes	2	8.00	97	0.37
Building Construction	Cranes	1	7.00	231	0.29
Building Construction	Forklifts	3	8.00	89	0.20
Building Construction	Generator Sets	1	8.00	84	0.74
Building Construction	Tractors/Loaders/Backhoes	3	7.00	97	0.37
Building Construction	Welders	1	8.00	46	0.45
Paving	Pavers	2	8.00	130	0.42
Paving	Paving Equipment	2	8.00	132	0.36
Paving	Rollers	2	8.00	80	0.38
Architectural Coating	Air Compressors	1	6.00	78	0.48

Trips and VMT

Village South Specific Plan (Proposed) - Los Angeles-South Coast County, Winter

Phase Name	Offroad Equipment Count	Worker Trip Number	Vendor Trip Number	Hauling Trip Number	Worker Trip Length	Vendor Trip Length	Hauling Trip Length	Worker Vehicle Class	Vendor Vehicle Class	Hauling Vehicle Class
Demolition	6	15.00	0.00	458.00	10.00	6.90	20.00	LD_Mix	HDT_Mix	HHDT
Site Preparation	7	18.00	0.00	0.00	10.00	6.90	20.00	LD_Mix	HDT_Mix	HHDT
Grading	8	20.00	0.00	0.00	10.00	6.90	20.00	LD_Mix	HDT_Mix	HHDT
Building Construction	9	801.00	143.00	0.00	10.00	6.90	20.00	LD_Mix	HDT_Mix	HHDT
Paving	6	15.00	0.00	0.00	10.00	6.90	20.00	LD_Mix	HDT_Mix	HHDT
Architectural Coating	1	160.00	0.00	0.00	10.00	6.90	20.00	LD_Mix	HDT_Mix	HHDT

3.1 Mitigation Measures Construction

3.2 Demolition - 2021

Unmitigated Construction On-Site

	ROG	NOx	CO	SO2	Fugitive PM10	Exhaust PM10	PM10 Total	Fugitive PM2.5	Exhaust PM2.5	PM2.5 Total	Bio- CO2	NBio- CO2	Total CO2	CH4	N2O	CO2e
Category	lb/day										lb/day					
Fugitive Dust					3.3074	0.0000	3.3074	0.5008	0.0000	0.5008			0.0000			0.0000
Off-Road	3.1651	31.4407	21.5650	0.0388		1.5513	1.5513		1.4411	1.4411		3,747.9449	3,747.9449	1.0549		3,774.3174
Total	3.1651	31.4407	21.5650	0.0388	3.3074	1.5513	4.8588	0.5008	1.4411	1.9419		3,747.9449	3,747.9449	1.0549		3,774.3174

Village South Specific Plan (Proposed) - Los Angeles-South Coast County, Winter

3.2 Demolition - 2021

Unmitigated Construction Off-Site

	ROG	NOx	CO	SO2	Fugitive PM10	Exhaust PM10	PM10 Total	Fugitive PM2.5	Exhaust PM2.5	PM2.5 Total	Bio- CO2	NBio- CO2	Total CO2	CH4	N2O	CO2e
Category	lb/day										lb/day					
Hauling	0.1304	4.1454	1.0182	0.0117	0.2669	0.0128	0.2797	0.0732	0.0122	0.0854		1,269.8555	1,269.8555	0.0908		1,272.1252
Vendor	0.0000	0.0000	0.0000	0.0000	0.0000	0.0000	0.0000	0.0000	0.0000	0.0000		0.0000	0.0000	0.0000		0.0000
Worker	0.0532	0.0346	0.3963	1.1100e-003	0.1141	9.5000e-004	0.1151	0.0303	8.8000e-004	0.0311		110.4707	110.4707	3.3300e-003		110.5539
Total	0.1835	4.1800	1.4144	0.0128	0.3810	0.0137	0.3948	0.1034	0.0131	0.1165		1,380.3262	1,380.3262	0.0941		1,382.6791

Mitigated Construction On-Site

	ROG	NOx	CO	SO2	Fugitive PM10	Exhaust PM10	PM10 Total	Fugitive PM2.5	Exhaust PM2.5	PM2.5 Total	Bio- CO2	NBio- CO2	Total CO2	CH4	N2O	CO2e
Category	lb/day										lb/day					
Fugitive Dust					3.3074	0.0000	3.3074	0.5008	0.0000	0.5008			0.0000			0.0000
Off-Road	3.1651	31.4407	21.5650	0.0388		1.5513	1.5513		1.4411	1.4411	0.0000	3,747.9449	3,747.9449	1.0549		3,774.3174
Total	3.1651	31.4407	21.5650	0.0388	3.3074	1.5513	4.8588	0.5008	1.4411	1.9419	0.0000	3,747.9449	3,747.9449	1.0549		3,774.3174

Village South Specific Plan (Proposed) - Los Angeles-South Coast County, Winter

3.2 Demolition - 2021

Mitigated Construction Off-Site

	ROG	NOx	CO	SO2	Fugitive PM10	Exhaust PM10	PM10 Total	Fugitive PM2.5	Exhaust PM2.5	PM2.5 Total	Bio- CO2	NBio- CO2	Total CO2	CH4	N2O	CO2e
Category	lb/day										lb/day					
Hauling	0.1304	4.1454	1.0182	0.0117	0.2669	0.0128	0.2797	0.0732	0.0122	0.0854		1,269.8555	1,269.8555	0.0908		1,272.1252
Vendor	0.0000	0.0000	0.0000	0.0000	0.0000	0.0000	0.0000	0.0000	0.0000	0.0000		0.0000	0.0000	0.0000		0.0000
Worker	0.0532	0.0346	0.3963	1.1100e-003	0.1141	9.5000e-004	0.1151	0.0303	8.8000e-004	0.0311		110.4707	110.4707	3.3300e-003		110.5539
Total	0.1835	4.1800	1.4144	0.0128	0.3810	0.0137	0.3948	0.1034	0.0131	0.1165		1,380.3262	1,380.3262	0.0941		1,382.6791

3.3 Site Preparation - 2021

Unmitigated Construction On-Site

	ROG	NOx	CO	SO2	Fugitive PM10	Exhaust PM10	PM10 Total	Fugitive PM2.5	Exhaust PM2.5	PM2.5 Total	Bio- CO2	NBio- CO2	Total CO2	CH4	N2O	CO2e
Category	lb/day										lb/day					
Fugitive Dust					18.0663	0.0000	18.0663	9.9307	0.0000	9.9307			0.0000			0.0000
Off-Road	3.8882	40.4971	21.1543	0.0380		2.0445	2.0445		1.8809	1.8809		3,685.6569	3,685.6569	1.1920		3,715.4573
Total	3.8882	40.4971	21.1543	0.0380	18.0663	2.0445	20.1107	9.9307	1.8809	11.8116		3,685.6569	3,685.6569	1.1920		3,715.4573

Village South Specific Plan (Proposed) - Los Angeles-South Coast County, Winter

3.3 Site Preparation - 2021

Unmitigated Construction Off-Site

	ROG	NOx	CO	SO2	Fugitive PM10	Exhaust PM10	PM10 Total	Fugitive PM2.5	Exhaust PM2.5	PM2.5 Total	Bio- CO2	NBio- CO2	Total CO2	CH4	N2O	CO2e
Category	lb/day										lb/day					
Hauling	0.0000	0.0000	0.0000	0.0000	0.0000	0.0000	0.0000	0.0000	0.0000	0.0000		0.0000	0.0000	0.0000		0.0000
Vendor	0.0000	0.0000	0.0000	0.0000	0.0000	0.0000	0.0000	0.0000	0.0000	0.0000		0.0000	0.0000	0.0000		0.0000
Worker	0.0638	0.0415	0.4755	1.3300e-003	0.1369	1.1400e-003	0.1381	0.0363	1.0500e-003	0.0374		132.5649	132.5649	3.9900e-003		132.6646
Total	0.0638	0.0415	0.4755	1.3300e-003	0.1369	1.1400e-003	0.1381	0.0363	1.0500e-003	0.0374		132.5649	132.5649	3.9900e-003		132.6646

Mitigated Construction On-Site

	ROG	NOx	CO	SO2	Fugitive PM10	Exhaust PM10	PM10 Total	Fugitive PM2.5	Exhaust PM2.5	PM2.5 Total	Bio- CO2	NBio- CO2	Total CO2	CH4	N2O	CO2e
Category	lb/day										lb/day					
Fugitive Dust					18.0663	0.0000	18.0663	9.9307	0.0000	9.9307			0.0000			0.0000
Off-Road	3.8882	40.4971	21.1543	0.0380		2.0445	2.0445		1.8809	1.8809	0.0000	3,685.6569	3,685.6569	1.1920		3,715.4573
Total	3.8882	40.4971	21.1543	0.0380	18.0663	2.0445	20.1107	9.9307	1.8809	11.8116	0.0000	3,685.6569	3,685.6569	1.1920		3,715.4573

Village South Specific Plan (Proposed) - Los Angeles-South Coast County, Winter

3.3 Site Preparation - 2021

Mitigated Construction Off-Site

	ROG	NOx	CO	SO2	Fugitive PM10	Exhaust PM10	PM10 Total	Fugitive PM2.5	Exhaust PM2.5	PM2.5 Total	Bio- CO2	NBio- CO2	Total CO2	CH4	N2O	CO2e
Category	lb/day										lb/day					
Hauling	0.0000	0.0000	0.0000	0.0000	0.0000	0.0000	0.0000	0.0000	0.0000	0.0000		0.0000	0.0000	0.0000		0.0000
Vendor	0.0000	0.0000	0.0000	0.0000	0.0000	0.0000	0.0000	0.0000	0.0000	0.0000		0.0000	0.0000	0.0000		0.0000
Worker	0.0638	0.0415	0.4755	1.3300e-003	0.1369	1.1400e-003	0.1381	0.0363	1.0500e-003	0.0374		132.5649	132.5649	3.9900e-003		132.6646
Total	0.0638	0.0415	0.4755	1.3300e-003	0.1369	1.1400e-003	0.1381	0.0363	1.0500e-003	0.0374		132.5649	132.5649	3.9900e-003		132.6646

3.4 Grading - 2021

Unmitigated Construction On-Site

	ROG	NOx	CO	SO2	Fugitive PM10	Exhaust PM10	PM10 Total	Fugitive PM2.5	Exhaust PM2.5	PM2.5 Total	Bio- CO2	NBio- CO2	Total CO2	CH4	N2O	CO2e
Category	lb/day										lb/day					
Fugitive Dust					8.6733	0.0000	8.6733	3.5965	0.0000	3.5965			0.0000			0.0000
Off-Road	4.1912	46.3998	30.8785	0.0620		1.9853	1.9853		1.8265	1.8265		6,007.0434	6,007.0434	1.9428		6,055.6134
Total	4.1912	46.3998	30.8785	0.0620	8.6733	1.9853	10.6587	3.5965	1.8265	5.4230		6,007.0434	6,007.0434	1.9428		6,055.6134

Village South Specific Plan (Proposed) - Los Angeles-South Coast County, Winter

3.4 Grading - 2021

Unmitigated Construction Off-Site

	ROG	NOx	CO	SO2	Fugitive PM10	Exhaust PM10	PM10 Total	Fugitive PM2.5	Exhaust PM2.5	PM2.5 Total	Bio- CO2	NBio- CO2	Total CO2	CH4	N2O	CO2e
Category	lb/day										lb/day					
Hauling	0.0000	0.0000	0.0000	0.0000	0.0000	0.0000	0.0000	0.0000	0.0000	0.0000		0.0000	0.0000	0.0000		0.0000
Vendor	0.0000	0.0000	0.0000	0.0000	0.0000	0.0000	0.0000	0.0000	0.0000	0.0000		0.0000	0.0000	0.0000		0.0000
Worker	0.0709	0.0462	0.5284	1.4800e-003	0.1521	1.2700e-003	0.1534	0.0404	1.1700e-003	0.0415		147.2943	147.2943	4.4300e-003		147.4051
Total	0.0709	0.0462	0.5284	1.4800e-003	0.1521	1.2700e-003	0.1534	0.0404	1.1700e-003	0.0415		147.2943	147.2943	4.4300e-003		147.4051

Mitigated Construction On-Site

	ROG	NOx	CO	SO2	Fugitive PM10	Exhaust PM10	PM10 Total	Fugitive PM2.5	Exhaust PM2.5	PM2.5 Total	Bio- CO2	NBio- CO2	Total CO2	CH4	N2O	CO2e
Category	lb/day										lb/day					
Fugitive Dust					8.6733	0.0000	8.6733	3.5965	0.0000	3.5965			0.0000			0.0000
Off-Road	4.1912	46.3998	30.8785	0.0620		1.9853	1.9853		1.8265	1.8265	0.0000	6,007.0434	6,007.0434	1.9428		6,055.6134
Total	4.1912	46.3998	30.8785	0.0620	8.6733	1.9853	10.6587	3.5965	1.8265	5.4230	0.0000	6,007.0434	6,007.0434	1.9428		6,055.6134

Village South Specific Plan (Proposed) - Los Angeles-South Coast County, Winter

3.4 Grading - 2021

Mitigated Construction Off-Site

	ROG	NOx	CO	SO2	Fugitive PM10	Exhaust PM10	PM10 Total	Fugitive PM2.5	Exhaust PM2.5	PM2.5 Total	Bio- CO2	NBio- CO2	Total CO2	CH4	N2O	CO2e
Category	lb/day										lb/day					
Hauling	0.0000	0.0000	0.0000	0.0000	0.0000	0.0000	0.0000	0.0000	0.0000	0.0000		0.0000	0.0000	0.0000		0.0000
Vendor	0.0000	0.0000	0.0000	0.0000	0.0000	0.0000	0.0000	0.0000	0.0000	0.0000		0.0000	0.0000	0.0000		0.0000
Worker	0.0709	0.0462	0.5284	1.4800e-003	0.1521	1.2700e-003	0.1534	0.0404	1.1700e-003	0.0415		147.2943	147.2943	4.4300e-003		147.4051
Total	0.0709	0.0462	0.5284	1.4800e-003	0.1521	1.2700e-003	0.1534	0.0404	1.1700e-003	0.0415		147.2943	147.2943	4.4300e-003		147.4051

3.4 Grading - 2022

Unmitigated Construction On-Site

	ROG	NOx	CO	SO2	Fugitive PM10	Exhaust PM10	PM10 Total	Fugitive PM2.5	Exhaust PM2.5	PM2.5 Total	Bio- CO2	NBio- CO2	Total CO2	CH4	N2O	CO2e
Category	lb/day										lb/day					
Fugitive Dust					8.6733	0.0000	8.6733	3.5965	0.0000	3.5965			0.0000			0.0000
Off-Road	3.6248	38.8435	29.0415	0.0621		1.6349	1.6349		1.5041	1.5041		6,011.4105	6,011.4105	1.9442		6,060.0158
Total	3.6248	38.8435	29.0415	0.0621	8.6733	1.6349	10.3082	3.5965	1.5041	5.1006		6,011.4105	6,011.4105	1.9442		6,060.0158

Village South Specific Plan (Proposed) - Los Angeles-South Coast County, Winter

3.4 Grading - 2022

Unmitigated Construction Off-Site

	ROG	NOx	CO	SO2	Fugitive PM10	Exhaust PM10	PM10 Total	Fugitive PM2.5	Exhaust PM2.5	PM2.5 Total	Bio- CO2	NBio- CO2	Total CO2	CH4	N2O	CO2e
Category	lb/day										lb/day					
Hauling	0.0000	0.0000	0.0000	0.0000	0.0000	0.0000	0.0000	0.0000	0.0000	0.0000		0.0000	0.0000	0.0000		0.0000
Vendor	0.0000	0.0000	0.0000	0.0000	0.0000	0.0000	0.0000	0.0000	0.0000	0.0000		0.0000	0.0000	0.0000		0.0000
Worker	0.0665	0.0416	0.4861	1.4300e-003	0.1521	1.2300e-003	0.1534	0.0404	1.1300e-003	0.0415		142.1207	142.1207	4.0000e-003		142.2207
Total	0.0665	0.0416	0.4861	1.4300e-003	0.1521	1.2300e-003	0.1534	0.0404	1.1300e-003	0.0415		142.1207	142.1207	4.0000e-003		142.2207

Mitigated Construction On-Site

	ROG	NOx	CO	SO2	Fugitive PM10	Exhaust PM10	PM10 Total	Fugitive PM2.5	Exhaust PM2.5	PM2.5 Total	Bio- CO2	NBio- CO2	Total CO2	CH4	N2O	CO2e
Category	lb/day										lb/day					
Fugitive Dust					8.6733	0.0000	8.6733	3.5965	0.0000	3.5965			0.0000			0.0000
Off-Road	3.6248	38.8435	29.0415	0.0621		1.6349	1.6349		1.5041	1.5041	0.0000	6,011.4105	6,011.4105	1.9442		6,060.0158
Total	3.6248	38.8435	29.0415	0.0621	8.6733	1.6349	10.3082	3.5965	1.5041	5.1006	0.0000	6,011.4105	6,011.4105	1.9442		6,060.0158

Village South Specific Plan (Proposed) - Los Angeles-South Coast County, Winter

3.4 Grading - 2022

Mitigated Construction Off-Site

	ROG	NOx	CO	SO2	Fugitive PM10	Exhaust PM10	PM10 Total	Fugitive PM2.5	Exhaust PM2.5	PM2.5 Total	Bio- CO2	NBio- CO2	Total CO2	CH4	N2O	CO2e
Category	lb/day										lb/day					
Hauling	0.0000	0.0000	0.0000	0.0000	0.0000	0.0000	0.0000	0.0000	0.0000	0.0000		0.0000	0.0000	0.0000		0.0000
Vendor	0.0000	0.0000	0.0000	0.0000	0.0000	0.0000	0.0000	0.0000	0.0000	0.0000		0.0000	0.0000	0.0000		0.0000
Worker	0.0665	0.0416	0.4861	1.4300e-003	0.1521	1.2300e-003	0.1534	0.0404	1.1300e-003	0.0415		142.1207	142.1207	4.0000e-003		142.2207
Total	0.0665	0.0416	0.4861	1.4300e-003	0.1521	1.2300e-003	0.1534	0.0404	1.1300e-003	0.0415		142.1207	142.1207	4.0000e-003		142.2207

3.5 Building Construction - 2022

Unmitigated Construction On-Site

	ROG	NOx	CO	SO2	Fugitive PM10	Exhaust PM10	PM10 Total	Fugitive PM2.5	Exhaust PM2.5	PM2.5 Total	Bio- CO2	NBio- CO2	Total CO2	CH4	N2O	CO2e
Category	lb/day										lb/day					
Off-Road	1.7062	15.6156	16.3634	0.0269		0.8090	0.8090		0.7612	0.7612		2,554.3336	2,554.3336	0.6120		2,569.6322
Total	1.7062	15.6156	16.3634	0.0269		0.8090	0.8090		0.7612	0.7612		2,554.3336	2,554.3336	0.6120		2,569.6322

Village South Specific Plan (Proposed) - Los Angeles-South Coast County, Winter

3.5 Building Construction - 2022

Unmitigated Construction Off-Site

	ROG	NOx	CO	SO2	Fugitive PM10	Exhaust PM10	PM10 Total	Fugitive PM2.5	Exhaust PM2.5	PM2.5 Total	Bio- CO2	NBio- CO2	Total CO2	CH4	N2O	CO2e
Category	lb/day										lb/day					
Hauling	0.0000	0.0000	0.0000	0.0000	0.0000	0.0000	0.0000	0.0000	0.0000	0.0000		0.0000	0.0000	0.0000		0.0000
Vendor	0.4284	13.1673	3.8005	0.0354	0.9155	0.0256	0.9412	0.2636	0.0245	0.2881		3,789.0750	3,789.0750	0.2381		3,795.0283
Worker	2.6620	1.6677	19.4699	0.0571	6.0932	0.0493	6.1425	1.6163	0.0454	1.6617		5,691.9354	5,691.9354	0.1602		5,695.9408
Total	3.0904	14.8350	23.2704	0.0926	7.0087	0.0749	7.0836	1.8799	0.0699	1.9498		9,481.0104	9,481.0104	0.3984		9,490.9691

Mitigated Construction On-Site

	ROG	NOx	CO	SO2	Fugitive PM10	Exhaust PM10	PM10 Total	Fugitive PM2.5	Exhaust PM2.5	PM2.5 Total	Bio- CO2	NBio- CO2	Total CO2	CH4	N2O	CO2e
Category	lb/day										lb/day					
Off-Road	1.7062	15.6156	16.3634	0.0269		0.8090	0.8090		0.7612	0.7612	0.0000	2,554.3336	2,554.3336	0.6120		2,569.6322
Total	1.7062	15.6156	16.3634	0.0269		0.8090	0.8090		0.7612	0.7612	0.0000	2,554.3336	2,554.3336	0.6120		2,569.6322

Village South Specific Plan (Proposed) - Los Angeles-South Coast County, Winter

3.5 Building Construction - 2022

Mitigated Construction Off-Site

	ROG	NOx	CO	SO2	Fugitive PM10	Exhaust PM10	PM10 Total	Fugitive PM2.5	Exhaust PM2.5	PM2.5 Total	Bio- CO2	NBio- CO2	Total CO2	CH4	N2O	CO2e
Category	lb/day										lb/day					
Hauling	0.0000	0.0000	0.0000	0.0000	0.0000	0.0000	0.0000	0.0000	0.0000	0.0000		0.0000	0.0000	0.0000		0.0000
Vendor	0.4284	13.1673	3.8005	0.0354	0.9155	0.0256	0.9412	0.2636	0.0245	0.2881		3,789.0750	3,789.0750	0.2381		3,795.0283
Worker	2.6620	1.6677	19.4699	0.0571	6.0932	0.0493	6.1425	1.6163	0.0454	1.6617		5,691.9354	5,691.9354	0.1602		5,695.9408
Total	3.0904	14.8350	23.2704	0.0926	7.0087	0.0749	7.0836	1.8799	0.0699	1.9498		9,481.0104	9,481.0104	0.3984		9,490.9691

3.5 Building Construction - 2023

Unmitigated Construction On-Site

	ROG	NOx	CO	SO2	Fugitive PM10	Exhaust PM10	PM10 Total	Fugitive PM2.5	Exhaust PM2.5	PM2.5 Total	Bio- CO2	NBio- CO2	Total CO2	CH4	N2O	CO2e
Category	lb/day										lb/day					
Off-Road	1.5728	14.3849	16.2440	0.0269		0.6997	0.6997		0.6584	0.6584		2,555.2099	2,555.2099	0.6079		2,570.4061
Total	1.5728	14.3849	16.2440	0.0269		0.6997	0.6997		0.6584	0.6584		2,555.2099	2,555.2099	0.6079		2,570.4061

Village South Specific Plan (Proposed) - Los Angeles-South Coast County, Winter

3.5 Building Construction - 2023

Unmitigated Construction Off-Site

	ROG	NOx	CO	SO2	Fugitive PM10	Exhaust PM10	PM10 Total	Fugitive PM2.5	Exhaust PM2.5	PM2.5 Total	Bio- CO2	NBio- CO2	Total CO2	CH4	N2O	CO2e
Category	lb/day										lb/day					
Hauling	0.0000	0.0000	0.0000	0.0000	0.0000	0.0000	0.0000	0.0000	0.0000	0.0000		0.0000	0.0000	0.0000		0.0000
Vendor	0.3183	9.9726	3.3771	0.0343	0.9156	0.0122	0.9277	0.2636	0.0116	0.2752		3,671.4007	3,671.4007	0.2096		3,676.6417
Worker	2.5029	1.5073	17.8820	0.0550	6.0932	0.0479	6.1411	1.6163	0.0441	1.6604		5,483.7974	5,483.7974	0.1442		5,487.4020
Total	2.8211	11.4799	21.2591	0.0893	7.0088	0.0601	7.0688	1.8799	0.0557	1.9356		9,155.1981	9,155.1981	0.3538		9,164.0437

Mitigated Construction On-Site

	ROG	NOx	CO	SO2	Fugitive PM10	Exhaust PM10	PM10 Total	Fugitive PM2.5	Exhaust PM2.5	PM2.5 Total	Bio- CO2	NBio- CO2	Total CO2	CH4	N2O	CO2e
Category	lb/day										lb/day					
Off-Road	1.5728	14.3849	16.2440	0.0269		0.6997	0.6997		0.6584	0.6584	0.0000	2,555.2099	2,555.2099	0.6079		2,570.4061
Total	1.5728	14.3849	16.2440	0.0269		0.6997	0.6997		0.6584	0.6584	0.0000	2,555.2099	2,555.2099	0.6079		2,570.4061

Village South Specific Plan (Proposed) - Los Angeles-South Coast County, Winter

3.5 Building Construction - 2023

Mitigated Construction Off-Site

	ROG	NOx	CO	SO2	Fugitive PM10	Exhaust PM10	PM10 Total	Fugitive PM2.5	Exhaust PM2.5	PM2.5 Total	Bio- CO2	NBio- CO2	Total CO2	CH4	N2O	CO2e
Category	lb/day										lb/day					
Hauling	0.0000	0.0000	0.0000	0.0000	0.0000	0.0000	0.0000	0.0000	0.0000	0.0000		0.0000	0.0000	0.0000		0.0000
Vendor	0.3183	9.9726	3.3771	0.0343	0.9156	0.0122	0.9277	0.2636	0.0116	0.2752		3,671.4007	3,671.4007	0.2096		3,676.6417
Worker	2.5029	1.5073	17.8820	0.0550	6.0932	0.0479	6.1411	1.6163	0.0441	1.6604		5,483.7974	5,483.7974	0.1442		5,487.4020
Total	2.8211	11.4799	21.2591	0.0893	7.0088	0.0601	7.0688	1.8799	0.0557	1.9356		9,155.1981	9,155.1981	0.3538		9,164.0437

3.6 Paving - 2023

Unmitigated Construction On-Site

	ROG	NOx	CO	SO2	Fugitive PM10	Exhaust PM10	PM10 Total	Fugitive PM2.5	Exhaust PM2.5	PM2.5 Total	Bio- CO2	NBio- CO2	Total CO2	CH4	N2O	CO2e
Category	lb/day										lb/day					
Off-Road	1.0327	10.1917	14.5842	0.0228		0.5102	0.5102		0.4694	0.4694		2,207.5841	2,207.5841	0.7140		2,225.4336
Paving	0.0000					0.0000	0.0000		0.0000	0.0000			0.0000			0.0000
Total	1.0327	10.1917	14.5842	0.0228		0.5102	0.5102		0.4694	0.4694		2,207.5841	2,207.5841	0.7140		2,225.4336

Village South Specific Plan (Proposed) - Los Angeles-South Coast County, Winter

3.6 Paving - 2023

Unmitigated Construction Off-Site

	ROG	NOx	CO	SO2	Fugitive PM10	Exhaust PM10	PM10 Total	Fugitive PM2.5	Exhaust PM2.5	PM2.5 Total	Bio- CO2	NBio- CO2	Total CO2	CH4	N2O	CO2e
Category	lb/day										lb/day					
Hauling	0.0000	0.0000	0.0000	0.0000	0.0000	0.0000	0.0000	0.0000	0.0000	0.0000		0.0000	0.0000	0.0000		0.0000
Vendor	0.0000	0.0000	0.0000	0.0000	0.0000	0.0000	0.0000	0.0000	0.0000	0.0000		0.0000	0.0000	0.0000		0.0000
Worker	0.0469	0.0282	0.3349	1.0300e-003	0.1141	9.0000e-004	0.1150	0.0303	8.3000e-004	0.0311		102.6928	102.6928	2.7000e-003		102.7603
Total	0.0469	0.0282	0.3349	1.0300e-003	0.1141	9.0000e-004	0.1150	0.0303	8.3000e-004	0.0311		102.6928	102.6928	2.7000e-003		102.7603

Mitigated Construction On-Site

	ROG	NOx	CO	SO2	Fugitive PM10	Exhaust PM10	PM10 Total	Fugitive PM2.5	Exhaust PM2.5	PM2.5 Total	Bio- CO2	NBio- CO2	Total CO2	CH4	N2O	CO2e
Category	lb/day										lb/day					
Off-Road	1.0327	10.1917	14.5842	0.0228		0.5102	0.5102		0.4694	0.4694	0.0000	2,207.5841	2,207.5841	0.7140		2,225.4336
Paving	0.0000					0.0000	0.0000		0.0000	0.0000			0.0000			0.0000
Total	1.0327	10.1917	14.5842	0.0228		0.5102	0.5102		0.4694	0.4694	0.0000	2,207.5841	2,207.5841	0.7140		2,225.4336

Village South Specific Plan (Proposed) - Los Angeles-South Coast County, Winter

3.6 Paving - 2023

Mitigated Construction Off-Site

	ROG	NOx	CO	SO2	Fugitive PM10	Exhaust PM10	PM10 Total	Fugitive PM2.5	Exhaust PM2.5	PM2.5 Total	Bio- CO2	NBio- CO2	Total CO2	CH4	N2O	CO2e
Category	lb/day										lb/day					
Hauling	0.0000	0.0000	0.0000	0.0000	0.0000	0.0000	0.0000	0.0000	0.0000	0.0000		0.0000	0.0000	0.0000		0.0000
Vendor	0.0000	0.0000	0.0000	0.0000	0.0000	0.0000	0.0000	0.0000	0.0000	0.0000		0.0000	0.0000	0.0000		0.0000
Worker	0.0469	0.0282	0.3349	1.0300e-003	0.1141	9.0000e-004	0.1150	0.0303	8.3000e-004	0.0311		102.6928	102.6928	2.7000e-003		102.7603
Total	0.0469	0.0282	0.3349	1.0300e-003	0.1141	9.0000e-004	0.1150	0.0303	8.3000e-004	0.0311		102.6928	102.6928	2.7000e-003		102.7603

3.6 Paving - 2024

Unmitigated Construction On-Site

	ROG	NOx	CO	SO2	Fugitive PM10	Exhaust PM10	PM10 Total	Fugitive PM2.5	Exhaust PM2.5	PM2.5 Total	Bio- CO2	NBio- CO2	Total CO2	CH4	N2O	CO2e
Category	lb/day										lb/day					
Off-Road	0.9882	9.5246	14.6258	0.0228		0.4685	0.4685		0.4310	0.4310		2,207.5472	2,207.5472	0.7140		2,225.3963
Paving	0.0000					0.0000	0.0000		0.0000	0.0000			0.0000			0.0000
Total	0.9882	9.5246	14.6258	0.0228		0.4685	0.4685		0.4310	0.4310		2,207.5472	2,207.5472	0.7140		2,225.3963

Village South Specific Plan (Proposed) - Los Angeles-South Coast County, Winter

3.6 Paving - 2024

Unmitigated Construction Off-Site

	ROG	NOx	CO	SO2	Fugitive PM10	Exhaust PM10	PM10 Total	Fugitive PM2.5	Exhaust PM2.5	PM2.5 Total	Bio- CO2	NBio- CO2	Total CO2	CH4	N2O	CO2e
Category	lb/day										lb/day					
Hauling	0.0000	0.0000	0.0000	0.0000	0.0000	0.0000	0.0000	0.0000	0.0000	0.0000		0.0000	0.0000	0.0000		0.0000
Vendor	0.0000	0.0000	0.0000	0.0000	0.0000	0.0000	0.0000	0.0000	0.0000	0.0000		0.0000	0.0000	0.0000		0.0000
Worker	0.0444	0.0257	0.3114	1.0000e-003	0.1141	8.8000e-004	0.1150	0.0303	8.1000e-004	0.0311		99.5045	99.5045	2.4700e-003		99.5663
Total	0.0444	0.0257	0.3114	1.0000e-003	0.1141	8.8000e-004	0.1150	0.0303	8.1000e-004	0.0311		99.5045	99.5045	2.4700e-003		99.5663

Mitigated Construction On-Site

	ROG	NOx	CO	SO2	Fugitive PM10	Exhaust PM10	PM10 Total	Fugitive PM2.5	Exhaust PM2.5	PM2.5 Total	Bio- CO2	NBio- CO2	Total CO2	CH4	N2O	CO2e
Category	lb/day										lb/day					
Off-Road	0.9882	9.5246	14.6258	0.0228		0.4685	0.4685		0.4310	0.4310	0.0000	2,207.5472	2,207.5472	0.7140		2,225.3963
Paving	0.0000					0.0000	0.0000		0.0000	0.0000			0.0000			0.0000
Total	0.9882	9.5246	14.6258	0.0228		0.4685	0.4685		0.4310	0.4310	0.0000	2,207.5472	2,207.5472	0.7140		2,225.3963

Village South Specific Plan (Proposed) - Los Angeles-South Coast County, Winter

3.6 Paving - 2024

Mitigated Construction Off-Site

	ROG	NOx	CO	SO2	Fugitive PM10	Exhaust PM10	PM10 Total	Fugitive PM2.5	Exhaust PM2.5	PM2.5 Total	Bio- CO2	NBio- CO2	Total CO2	CH4	N2O	CO2e
Category	lb/day										lb/day					
Hauling	0.0000	0.0000	0.0000	0.0000	0.0000	0.0000	0.0000	0.0000	0.0000	0.0000		0.0000	0.0000	0.0000		0.0000
Vendor	0.0000	0.0000	0.0000	0.0000	0.0000	0.0000	0.0000	0.0000	0.0000	0.0000		0.0000	0.0000	0.0000		0.0000
Worker	0.0444	0.0257	0.3114	1.0000e-003	0.1141	8.8000e-004	0.1150	0.0303	8.1000e-004	0.0311		99.5045	99.5045	2.4700e-003		99.5663
Total	0.0444	0.0257	0.3114	1.0000e-003	0.1141	8.8000e-004	0.1150	0.0303	8.1000e-004	0.0311		99.5045	99.5045	2.4700e-003		99.5663

3.7 Architectural Coating - 2024

Unmitigated Construction On-Site

	ROG	NOx	CO	SO2	Fugitive PM10	Exhaust PM10	PM10 Total	Fugitive PM2.5	Exhaust PM2.5	PM2.5 Total	Bio- CO2	NBio- CO2	Total CO2	CH4	N2O	CO2e
Category	lb/day										lb/day					
Archit. Coating	236.4115					0.0000	0.0000		0.0000	0.0000			0.0000			0.0000
Off-Road	0.1808	1.2188	1.8101	2.9700e-003		0.0609	0.0609		0.0609	0.0609		281.4481	281.4481	0.0159		281.8443
Total	236.5923	1.2188	1.8101	2.9700e-003		0.0609	0.0609		0.0609	0.0609		281.4481	281.4481	0.0159		281.8443

Village South Specific Plan (Proposed) - Los Angeles-South Coast County, Winter

3.7 Architectural Coating - 2024

Unmitigated Construction Off-Site

	ROG	NOx	CO	SO2	Fugitive PM10	Exhaust PM10	PM10 Total	Fugitive PM2.5	Exhaust PM2.5	PM2.5 Total	Bio- CO2	NBio- CO2	Total CO2	CH4	N2O	CO2e
Category	lb/day										lb/day					
Hauling	0.0000	0.0000	0.0000	0.0000	0.0000	0.0000	0.0000	0.0000	0.0000	0.0000		0.0000	0.0000	0.0000		0.0000
Vendor	0.0000	0.0000	0.0000	0.0000	0.0000	0.0000	0.0000	0.0000	0.0000	0.0000		0.0000	0.0000	0.0000		0.0000
Worker	0.4734	0.2743	3.3220	0.0107	1.2171	9.4300e-003	1.2266	0.3229	8.6800e-003	0.3315		1,061.3818	1,061.3818	0.0264		1,062.0410
Total	0.4734	0.2743	3.3220	0.0107	1.2171	9.4300e-003	1.2266	0.3229	8.6800e-003	0.3315		1,061.3818	1,061.3818	0.0264		1,062.0410

Mitigated Construction On-Site

	ROG	NOx	CO	SO2	Fugitive PM10	Exhaust PM10	PM10 Total	Fugitive PM2.5	Exhaust PM2.5	PM2.5 Total	Bio- CO2	NBio- CO2	Total CO2	CH4	N2O	CO2e
Category	lb/day										lb/day					
Archit. Coating	236.4115					0.0000	0.0000		0.0000	0.0000			0.0000			0.0000
Off-Road	0.1808	1.2188	1.8101	2.9700e-003		0.0609	0.0609		0.0609	0.0609	0.0000	281.4481	281.4481	0.0159		281.8443
Total	236.5923	1.2188	1.8101	2.9700e-003		0.0609	0.0609		0.0609	0.0609	0.0000	281.4481	281.4481	0.0159		281.8443

Village South Specific Plan (Proposed) - Los Angeles-South Coast County, Winter

3.7 Architectural Coating - 2024

Mitigated Construction Off-Site

	ROG	NOx	CO	SO2	Fugitive PM10	Exhaust PM10	PM10 Total	Fugitive PM2.5	Exhaust PM2.5	PM2.5 Total	Bio- CO2	NBio- CO2	Total CO2	CH4	N2O	CO2e
Category	lb/day										lb/day					
Hauling	0.0000	0.0000	0.0000	0.0000	0.0000	0.0000	0.0000	0.0000	0.0000	0.0000		0.0000	0.0000	0.0000		0.0000
Vendor	0.0000	0.0000	0.0000	0.0000	0.0000	0.0000	0.0000	0.0000	0.0000	0.0000		0.0000	0.0000	0.0000		0.0000
Worker	0.4734	0.2743	3.3220	0.0107	1.2171	9.4300e-003	1.2266	0.3229	8.6800e-003	0.3315		1,061.3818	1,061.3818	0.0264		1,062.0410
Total	0.4734	0.2743	3.3220	0.0107	1.2171	9.4300e-003	1.2266	0.3229	8.6800e-003	0.3315		1,061.3818	1,061.3818	0.0264		1,062.0410

4.0 Operational Detail - Mobile

4.1 Mitigation Measures Mobile

Village South Specific Plan (Proposed) - Los Angeles-South Coast County, Winter

	ROG	NOx	CO	SO2	Fugitive PM10	Exhaust PM10	PM10 Total	Fugitive PM2.5	Exhaust PM2.5	PM2.5 Total	Bio- CO2	NBio- CO2	Total CO2	CH4	N2O	CO2e
Category	lb/day										lb/day					
Mitigated	9.5233	45.9914	110.0422	0.4681	45.9592	0.3373	46.2965	12.2950	0.3132	12.6083		47,917.8005	47,917.8005	2.1953		47,972.6839
Unmitigated	9.5233	45.9914	110.0422	0.4681	45.9592	0.3373	46.2965	12.2950	0.3132	12.6083		47,917.8005	47,917.8005	2.1953		47,972.6839

4.2 Trip Summary Information

Land Use	Average Daily Trip Rate			Unmitigated	Mitigated
	Weekday	Saturday	Sunday	Annual VMT	Annual VMT
Apartments Low Rise	145.75	154.25	154.00	506,227	506,227
Apartments Mid Rise	4,026.75	3,773.25	4075.50	13,660,065	13,660,065
General Office Building	288.45	62.55	31.05	706,812	706,812
High Turnover (Sit Down Restaurant)	2,368.80	2,873.52	2817.72	3,413,937	3,413,937
Hotel	192.00	187.50	160.00	445,703	445,703
Quality Restaurant	501.12	511.92	461.20	707,488	707,488
Regional Shopping Center	528.08	601.44	357.84	1,112,221	1,112,221
Total	8,050.95	8,164.43	8,057.31	20,552,452	20,552,452

4.3 Trip Type Information

Village South Specific Plan (Proposed) - Los Angeles-South Coast County, Winter

Land Use	Miles			Trip %			Trip Purpose %		
	H-W or C-W	H-S or C-C	H-O or C-NW	H-W or C-W	H-S or C-C	H-O or C-NW	Primary	Diverted	Pass-by
Apartments Low Rise	14.70	5.90	8.70	40.20	19.20	40.60	86	11	3
Apartments Mid Rise	14.70	5.90	8.70	40.20	19.20	40.60	86	11	3
General Office Building	16.60	8.40	6.90	33.00	48.00	19.00	77	19	4
High Turnover (Sit Down Restaurant)	16.60	8.40	6.90	8.50	72.50	19.00	37	20	43
Hotel	16.60	8.40	6.90	19.40	61.60	19.00	58	38	4
Quality Restaurant	16.60	8.40	6.90	12.00	69.00	19.00	38	18	44
Regional Shopping Center	16.60	8.40	6.90	16.30	64.70	19.00	54	35	11

4.4 Fleet Mix

Land Use	LDA	LDT1	LDT2	MDV	LHD1	LHD2	MHD	HHD	OBUS	UBUS	MCY	SBUS	MH
Apartments Low Rise	0.543088	0.044216	0.209971	0.116369	0.014033	0.006332	0.021166	0.033577	0.002613	0.001817	0.005285	0.000712	0.000821
Apartments Mid Rise	0.543088	0.044216	0.209971	0.116369	0.014033	0.006332	0.021166	0.033577	0.002613	0.001817	0.005285	0.000712	0.000821
General Office Building	0.543088	0.044216	0.209971	0.116369	0.014033	0.006332	0.021166	0.033577	0.002613	0.001817	0.005285	0.000712	0.000821
High Turnover (Sit Down Restaurant)	0.543088	0.044216	0.209971	0.116369	0.014033	0.006332	0.021166	0.033577	0.002613	0.001817	0.005285	0.000712	0.000821
Hotel	0.543088	0.044216	0.209971	0.116369	0.014033	0.006332	0.021166	0.033577	0.002613	0.001817	0.005285	0.000712	0.000821
Quality Restaurant	0.543088	0.044216	0.209971	0.116369	0.014033	0.006332	0.021166	0.033577	0.002613	0.001817	0.005285	0.000712	0.000821
Regional Shopping Center	0.543088	0.044216	0.209971	0.116369	0.014033	0.006332	0.021166	0.033577	0.002613	0.001817	0.005285	0.000712	0.000821

5.0 Energy Detail

Historical Energy Use: N

5.1 Mitigation Measures Energy

Village South Specific Plan (Proposed) - Los Angeles-South Coast County, Winter

	ROG	NOx	CO	SO2	Fugitive PM10	Exhaust PM10	PM10 Total	Fugitive PM2.5	Exhaust PM2.5	PM2.5 Total	Bio- CO2	NBio- CO2	Total CO2	CH4	N2O	CO2e
Category	lb/day										lb/day					
NaturalGas Mitigated	0.7660	6.7462	4.2573	0.0418		0.5292	0.5292		0.5292	0.5292		8,355.983 2	8,355.983 2	0.1602	0.1532	8,405.638 7
NaturalGas Unmitigated	0.7660	6.7462	4.2573	0.0418		0.5292	0.5292		0.5292	0.5292		8,355.983 2	8,355.983 2	0.1602	0.1532	8,405.638 7

Village South Specific Plan (Proposed) - Los Angeles-South Coast County, Winter

5.2 Energy by Land Use - NaturalGas

Unmitigated

	NaturalGas Use	ROG	NOx	CO	SO2	Fugitive PM10	Exhaust PM10	PM10 Total	Fugitive PM2.5	Exhaust PM2.5	PM2.5 Total	Bio- CO2	NBio- CO2	Total CO2	CH4	N2O	CO2e
Land Use	kBTU/yr	lb/day										lb/day					
Apartments Low Rise	1119.16	0.0121	0.1031	0.0439	6.6000e-004		8.3400e-003	8.3400e-003		8.3400e-003	8.3400e-003		131.6662	131.6662	2.5200e-003	2.4100e-003	132.4486
Apartments Mid Rise	35784.3	0.3859	3.2978	1.4033	0.0211		0.2666	0.2666		0.2666	0.2666		4,209.9164	4,209.9164	0.0807	0.0772	4,234.9339
General Office Building	1283.42	0.0138	0.1258	0.1057	7.5000e-004		9.5600e-003	9.5600e-003		9.5600e-003	9.5600e-003		150.9911	150.9911	2.8900e-003	2.7700e-003	151.8884
High Turnover (Sit Down Restaurant)	22759.9	0.2455	2.2314	1.8743	0.0134		0.1696	0.1696		0.1696	0.1696		2,677.6342	2,677.6342	0.0513	0.0491	2,693.5460
Hotel	4769.72	0.0514	0.4676	0.3928	2.8100e-003		0.0355	0.0355		0.0355	0.0355		561.1436	561.1436	0.0108	0.0103	564.4782
Quality Restaurant	5057.75	0.0545	0.4959	0.4165	2.9800e-003		0.0377	0.0377		0.0377	0.0377		595.0298	595.0298	0.0114	0.0109	598.5658
Regional Shopping Center	251.616	2.7100e-003	0.0247	0.0207	1.5000e-004		1.8700e-003	1.8700e-003		1.8700e-003	1.8700e-003		29.6019	29.6019	5.7000e-004	5.4000e-004	29.7778
Total		0.7660	6.7463	4.2573	0.0418		0.5292	0.5292		0.5292	0.5292		8,355.9832	8,355.9832	0.1602	0.1532	8,405.6387

Village South Specific Plan (Proposed) - Los Angeles-South Coast County, Winter

5.2 Energy by Land Use - NaturalGas

Mitigated

	NaturalGas Use	ROG	NOx	CO	SO2	Fugitive PM10	Exhaust PM10	PM10 Total	Fugitive PM2.5	Exhaust PM2.5	PM2.5 Total	Bio- CO2	NBio- CO2	Total CO2	CH4	N2O	CO2e
Land Use	kBTU/yr	lb/day										lb/day					
Apartments Low Rise	1.11916	0.0121	0.1031	0.0439	6.6000e-004		8.3400e-003	8.3400e-003		8.3400e-003	8.3400e-003		131.6662	131.6662	2.5200e-003	2.4100e-003	132.4486
Apartments Mid Rise	35.7843	0.3859	3.2978	1.4033	0.0211		0.2666	0.2666		0.2666	0.2666		4,209.9164	4,209.9164	0.0807	0.0772	4,234.9339
General Office Building	1.28342	0.0138	0.1258	0.1057	7.5000e-004		9.5600e-003	9.5600e-003		9.5600e-003	9.5600e-003		150.9911	150.9911	2.8900e-003	2.7700e-003	151.8884
High Turnover (Sit Down Restaurant)	22.7599	0.2455	2.2314	1.8743	0.0134		0.1696	0.1696		0.1696	0.1696		2,677.6342	2,677.6342	0.0513	0.0491	2,693.5460
Hotel	4.76972	0.0514	0.4676	0.3928	2.8100e-003		0.0355	0.0355		0.0355	0.0355		561.1436	561.1436	0.0108	0.0103	564.4782
Quality Restaurant	5.05775	0.0545	0.4959	0.4165	2.9800e-003		0.0377	0.0377		0.0377	0.0377		595.0298	595.0298	0.0114	0.0109	598.5658
Regional Shopping Center	0.251616	2.7100e-003	0.0247	0.0207	1.5000e-004		1.8700e-003	1.8700e-003		1.8700e-003	1.8700e-003		29.6019	29.6019	5.7000e-004	5.4000e-004	29.7778
Total		0.7660	6.7463	4.2573	0.0418		0.5292	0.5292		0.5292	0.5292		8,355.9832	8,355.9832	0.1602	0.1532	8,405.6387

6.0 Area Detail

6.1 Mitigation Measures Area

Village South Specific Plan (Proposed) - Los Angeles-South Coast County, Winter

	ROG	NOx	CO	SO2	Fugitive PM10	Exhaust PM10	PM10 Total	Fugitive PM2.5	Exhaust PM2.5	PM2.5 Total	Bio- CO2	NBio- CO2	Total CO2	CH4	N2O	CO2e
Category	lb/day										lb/day					
Mitigated	30.5020	15.0496	88.4430	0.0944		1.5974	1.5974		1.5974	1.5974	0.0000	18,148.5950	18,148.5950	0.4874	0.3300	18,259.1192
Unmitigated	30.5020	15.0496	88.4430	0.0944		1.5974	1.5974		1.5974	1.5974	0.0000	18,148.5950	18,148.5950	0.4874	0.3300	18,259.1192

6.2 Area by SubCategory

Unmitigated

	ROG	NOx	CO	SO2	Fugitive PM10	Exhaust PM10	PM10 Total	Fugitive PM2.5	Exhaust PM2.5	PM2.5 Total	Bio- CO2	NBio- CO2	Total CO2	CH4	N2O	CO2e
SubCategory	lb/day										lb/day					
Architectural Coating	2.2670					0.0000	0.0000		0.0000	0.0000			0.0000			0.0000
Consumer Products	24.1085					0.0000	0.0000		0.0000	0.0000			0.0000			0.0000
Hearth	1.6500	14.1000	6.0000	0.0900		1.1400	1.1400		1.1400	1.1400	0.0000	18,000.0000	18,000.0000	0.3450	0.3300	18,106.9650
Landscaping	2.4766	0.9496	82.4430	4.3600e-003		0.4574	0.4574		0.4574	0.4574		148.5950	148.5950	0.1424		152.1542
Total	30.5020	15.0496	88.4430	0.0944		1.5974	1.5974		1.5974	1.5974	0.0000	18,148.5950	18,148.5950	0.4874	0.3300	18,259.1192

Village South Specific Plan (Proposed) - Los Angeles-South Coast County, Winter

6.2 Area by SubCategory

Mitigated

	ROG	NOx	CO	SO2	Fugitive PM10	Exhaust PM10	PM10 Total	Fugitive PM2.5	Exhaust PM2.5	PM2.5 Total	Bio- CO2	NBio- CO2	Total CO2	CH4	N2O	CO2e
SubCategory	lb/day										lb/day					
Architectural Coating	2.2670					0.0000	0.0000		0.0000	0.0000			0.0000			0.0000
Consumer Products	24.1085					0.0000	0.0000		0.0000	0.0000			0.0000			0.0000
Hearth	1.6500	14.1000	6.0000	0.0900		1.1400	1.1400		1.1400	1.1400	0.0000	18,000.0000	18,000.0000	0.3450	0.3300	18,106.9650
Landscaping	2.4766	0.9496	82.4430	4.3600e-003		0.4574	0.4574		0.4574	0.4574		148.5950	148.5950	0.1424		152.1542
Total	30.5020	15.0496	88.4430	0.0944		1.5974	1.5974		1.5974	1.5974	0.0000	18,148.5950	18,148.5950	0.4874	0.3300	18,259.1192

7.0 Water Detail

7.1 Mitigation Measures Water

8.0 Waste Detail

8.1 Mitigation Measures Waste

9.0 Operational Offroad

Equipment Type	Number	Hours/Day	Days/Year	Horse Power	Load Factor	Fuel Type
----------------	--------	-----------	-----------	-------------	-------------	-----------

10.0 Stationary Equipment

Village South Specific Plan (Proposed) - Los Angeles-South Coast County, Winter

Fire Pumps and Emergency Generators

Equipment Type	Number	Hours/Day	Hours/Year	Horse Power	Load Factor	Fuel Type
----------------	--------	-----------	------------	-------------	-------------	-----------

Boilers

Equipment Type	Number	Heat Input/Day	Heat Input/Year	Boiler Rating	Fuel Type
----------------	--------	----------------	-----------------	---------------	-----------

User Defined Equipment

Equipment Type	Number
----------------	--------

11.0 Vegetation

Attachment C

Local Hire Provision Net Change	
Without Local Hire Provision	
Total Construction GHG Emissions (MT CO ₂ e)	3,623
Amortized (MT CO ₂ e/year)	120.77
With Local Hire Provision	
Total Construction GHG Emissions (MT CO ₂ e)	3,024
Amortized (MT CO ₂ e/year)	100.80
<i>% Decrease in Construction-related GHG Emissions</i>	17%

EXHIBIT B



Paul Rosenfeld, Ph.D.

Principal Environmental Chemist

Chemical Fate and Transport & Air Dispersion Modeling

Risk Assessment & Remediation Specialist

Education

Ph.D. Soil Chemistry, University of Washington, 1999. Dissertation on volatile organic compound filtration.

M.S. Environmental Science, U.C. Berkeley, 1995. Thesis on organic waste economics.

B.A. Environmental Studies, U.C. Santa Barbara, 1991. Thesis on wastewater treatment.

Professional Experience

Dr. Rosenfeld has over 25 years' experience conducting environmental investigations and risk assessments for evaluating impacts to human health, property, and ecological receptors. His expertise focuses on the fate and transport of environmental contaminants, human health risk, exposure assessment, and ecological restoration. Dr. Rosenfeld has evaluated and modeled emissions from unconventional oil drilling operations, oil spills, landfills, boilers and incinerators, process stacks, storage tanks, confined animal feeding operations, and many other industrial and agricultural sources. His project experience ranges from monitoring and modeling of pollution sources to evaluating impacts of pollution on workers at industrial facilities and residents in surrounding communities.

Dr. Rosenfeld has investigated and designed remediation programs and risk assessments for contaminated sites containing lead, heavy metals, mold, bacteria, particulate matter, petroleum hydrocarbons, chlorinated solvents, pesticides, radioactive waste, dioxins and furans, semi- and volatile organic compounds, PCBs, PAHs, perchlorate, asbestos, per- and poly-fluoroalkyl substances (PFOA/PFOS), unusual polymers, fuel oxygenates (MTBE), among other pollutants. Dr. Rosenfeld also has experience evaluating greenhouse gas emissions from various projects and is an expert on the assessment of odors from industrial and agricultural sites, as well as the evaluation of odor nuisance impacts and technologies for abatement of odorous emissions. As a principal scientist at SWAPE, Dr. Rosenfeld directs air dispersion modeling and exposure assessments. He has served as an expert witness and testified about pollution sources causing nuisance and/or personal injury at dozens of sites and has testified as an expert witness on more than ten cases involving exposure to air contaminants from industrial sources.

Professional History:

Soil Water Air Protection Enterprise (SWAPE); 2003 to present; Principal and Founding Partner
UCLA School of Public Health; 2007 to 2011; Lecturer (Assistant Researcher)
UCLA School of Public Health; 2003 to 2006; Adjunct Professor
UCLA Environmental Science and Engineering Program; 2002-2004; Doctoral Intern Coordinator
UCLA Institute of the Environment, 2001-2002; Research Associate
Komex H₂O Science, 2001 to 2003; Senior Remediation Scientist
National Groundwater Association, 2002-2004; Lecturer
San Diego State University, 1999-2001; Adjunct Professor
Anteon Corp., San Diego, 2000-2001; Remediation Project Manager
Ogden (now Amec), San Diego, 2000-2000; Remediation Project Manager
Bechtel, San Diego, California, 1999 – 2000; Risk Assessor
King County, Seattle, 1996 – 1999; Scientist
James River Corp., Washington, 1995-96; Scientist
Big Creek Lumber, Davenport, California, 1995; Scientist
Plumas Corp., California and USFS, Tahoe 1993-1995; Scientist
Peace Corps and World Wildlife Fund, St. Kitts, West Indies, 1991-1993; Scientist

Publications:

Remy, L.L., Clay T., Byers, V., **Rosenfeld P. E.** (2019) Hospital, Health, and Community Burden After Oil Refinery Fires, Richmond, California 2007 and 2012. *Environmental Health*. 18:48

Simons, R.A., Seo, Y. **Rosenfeld, P.**, (2015) Modeling the Effect of Refinery Emission On Residential Property Value. *Journal of Real Estate Research*. 27(3):321-342

Chen, J. A, Zapata A. R., Sutherland A. J., Molmen, D.R., Chow, B. S., Wu, L. E., **Rosenfeld, P. E.**, Hesse, R. C., (2012) Sulfur Dioxide and Volatile Organic Compound Exposure To A Community In Texas City Texas Evaluated Using Aermol and Empirical Data. *American Journal of Environmental Science*, 8(6), 622-632.

Rosenfeld, P.E. & Feng, L. (2011). *The Risks of Hazardous Waste*. Amsterdam: Elsevier Publishing.

Cheremisinoff, N.P., & **Rosenfeld, P.E.** (2011). *Handbook of Pollution Prevention and Cleaner Production: Best Practices in the Agrochemical Industry*, Amsterdam: Elsevier Publishing.

Gonzalez, J., Feng, L., Sutherland, A., Waller, C., Sok, H., Hesse, R., **Rosenfeld, P.** (2010). PCBs and Dioxins/Furans in Attic Dust Collected Near Former PCB Production and Secondary Copper Facilities in Sauget, IL. *Procedia Environmental Sciences*. 113–125.

Feng, L., Wu, C., Tam, L., Sutherland, A.J., Clark, J.J., **Rosenfeld, P.E.** (2010). Dioxin and Furan Blood Lipid and Attic Dust Concentrations in Populations Living Near Four Wood Treatment Facilities in the United States. *Journal of Environmental Health*. 73(6), 34-46.

Cheremisinoff, N.P., & **Rosenfeld, P.E.** (2010). *Handbook of Pollution Prevention and Cleaner Production: Best Practices in the Wood and Paper Industries*. Amsterdam: Elsevier Publishing.

Cheremisinoff, N.P., & **Rosenfeld, P.E.** (2009). *Handbook of Pollution Prevention and Cleaner Production: Best Practices in the Petroleum Industry*. Amsterdam: Elsevier Publishing.

Wu, C., Tam, L., Clark, J., **Rosenfeld, P.** (2009). Dioxin and furan blood lipid concentrations in populations living near four wood treatment facilities in the United States. *WIT Transactions on Ecology and the Environment, Air Pollution*, 123 (17), 319-327.

Tam L. K., Wu C. D., Clark J. J. and **Rosenfeld, P.E.** (2008). A Statistical Analysis Of Attic Dust And Blood Lipid Concentrations Of Tetrachloro-p-Dibenzodioxin (TCDD) Toxicity Equivalency Quotients (TEQ) In Two Populations Near Wood Treatment Facilities. *Organohalogen Compounds*, 70, 002252-002255.

Tam L. K., Wu C. D., Clark J. J. and **Rosenfeld, P.E.** (2008). Methods For Collect Samples For Assessing Dioxins And Other Environmental Contaminants In Attic Dust: A Review. *Organohalogen Compounds*, 70, 000527-000530.

Hensley, A.R. A. Scott, J. J. J. Clark, **Rosenfeld, P.E.** (2007). Attic Dust and Human Blood Samples Collected near a Former Wood Treatment Facility. *Environmental Research*. 105, 194-197.

Rosenfeld, P.E., J. J. J. Clark, A. R. Hensley, M. Suffet. (2007). The Use of an Odor Wheel Classification for Evaluation of Human Health Risk Criteria for Compost Facilities. *Water Science & Technology* 55(5), 345-357.

Rosenfeld, P. E., M. Suffet. (2007). The Anatomy Of Odour Wheels For Odours Of Drinking Water, Wastewater, Compost And The Urban Environment. *Water Science & Technology* 55(5), 335-344.

Sullivan, P. J. Clark, J.J.J., Agardy, F. J., **Rosenfeld, P.E.** (2007). *Toxic Legacy, Synthetic Toxins in the Food, Water, and Air in American Cities*. Boston Massachusetts: Elsevier Publishing

Rosenfeld, P.E., and Suffet I.H. (2004). Control of Compost Odor Using High Carbon Wood Ash. *Water Science and Technology*. 49(9),171-178.

Rosenfeld P. E., J.J. Clark, I.H. (Mel) Suffet (2004). The Value of An Odor-Quality-Wheel Classification Scheme For The Urban Environment. *Water Environment Federation's Technical Exhibition and Conference (WEFTEC) 2004*. New Orleans, October 2-6, 2004.

Rosenfeld, P.E., and Suffet, I.H. (2004). Understanding Odorants Associated With Compost, Biomass Facilities, and the Land Application of Biosolids. *Water Science and Technology*. 49(9), 193-199.

Rosenfeld, P.E., and Suffet I.H. (2004). Control of Compost Odor Using High Carbon Wood Ash, *Water Science and Technology*, 49(9), 171-178.

Rosenfeld, P. E., Grey, M. A., Sellev, P. (2004). Measurement of Biosolids Odor and Odorant Emissions from Windrows, Static Pile and Biofilter. *Water Environment Research*. 76(4), 310-315.

Rosenfeld, P.E., Grey, M and Suffet, M. (2002). Compost Demonstration Project, Sacramento California Using High-Carbon Wood Ash to Control Odor at a Green Materials Composting Facility. *Integrated Waste Management Board Public Affairs Office, Publications Clearinghouse (MS-6)*, Sacramento, CA Publication #442-02-008.

Rosenfeld, P.E., and C.L. Henry. (2001). Characterization of odor emissions from three different biosolids. *Water Soil and Air Pollution*. 127(1-4), 173-191.

Rosenfeld, P.E., and Henry C. L., (2000). Wood ash control of odor emissions from biosolids application. *Journal of Environmental Quality*. 29, 1662-1668.

Rosenfeld, P.E., C.L. Henry and D. Bennett. (2001). Wastewater dewatering polymer affect on biosolids odor emissions and microbial activity. *Water Environment Research*. 73(4), 363-367.

Rosenfeld, P.E., and C.L. Henry. (2001). Activated Carbon and Wood Ash Sorption of Wastewater, Compost, and Biosolids Odorants. *Water Environment Research*, 73, 388-393.

Rosenfeld, P.E., and Henry C. L., (2001). High carbon wood ash effect on biosolids microbial activity and odor. *Water Environment Research*. 131(1-4), 247-262.

Chollack, T. and **P. Rosenfeld**. (1998). Compost Amendment Handbook For Landscaping. Prepared for and distributed by the City of Redmond, Washington State.

Rosenfeld, P. E. (1992). The Mount Liamuiga Crater Trail. *Heritage Magazine of St. Kitts*, 3(2).

Rosenfeld, P. E. (1993). High School Biogas Project to Prevent Deforestation On St. Kitts. *Biomass Users Network*, 7(1).

Rosenfeld, P. E. (1998). Characterization, Quantification, and Control of Odor Emissions From Biosolids Application To Forest Soil. Doctoral Thesis. University of Washington College of Forest Resources.

Rosenfeld, P. E. (1994). Potential Utilization of Small Diameter Trees on Sierra County Public Land. Masters thesis reprinted by the Sierra County Economic Council. Sierra County, California.

Rosenfeld, P. E. (1991). How to Build a Small Rural Anaerobic Digester & Uses Of Biogas In The First And Third World. Bachelors Thesis. University of California.

Presentations:

Rosenfeld, P.E., Sutherland, A; Hesse, R.; Zapata, A. (October 3-6, 2013). Air dispersion modeling of volatile organic emissions from multiple natural gas wells in Decatur, TX. *44th Western Regional Meeting, American Chemical Society*. Lecture conducted from Santa Clara, CA.

Sok, H.L.; Waller, C.C.; Feng, L.; Gonzalez, J.; Sutherland, A.J.; Wisdom-Stack, T.; Sahai, R.K.; Hesse, R.C.; **Rosenfeld, P.E.** (June 20-23, 2010). Atrazine: A Persistent Pesticide in Urban Drinking Water. *Urban Environmental Pollution*. Lecture conducted from Boston, MA.

Feng, L.; Gonzalez, J.; Sok, H.L.; Sutherland, A.J.; Waller, C.C.; Wisdom-Stack, T.; Sahai, R.K.; La, M.; Hesse, R.C.; **Rosenfeld, P.E.** (June 20-23, 2010). Bringing Environmental Justice to East St. Louis, Illinois. *Urban Environmental Pollution*. Lecture conducted from Boston, MA.

Rosenfeld, P.E. (April 19-23, 2009). Perfluorooctanoic Acid (PFOA) and Perfluorooctane Sulfonate (PFOS) Contamination in Drinking Water From the Use of Aqueous Film Forming Foams (AFFF) at Airports in the United States. *2009 Ground Water Summit and 2009 Ground Water Protection Council Spring Meeting*, Lecture conducted from Tuscon, AZ.

Rosenfeld, P.E. (April 19-23, 2009). Cost to Filter Atrazine Contamination from Drinking Water in the United States” Contamination in Drinking Water From the Use of Aqueous Film Forming Foams (AFFF) at Airports in the United States. *2009 Ground Water Summit and 2009 Ground Water Protection Council Spring Meeting*. Lecture conducted from Tuscon, AZ.

Wu, C., Tam, L., Clark, J., **Rosenfeld, P.** (20-22 July, 2009). Dioxin and furan blood lipid concentrations in populations living near four wood treatment facilities in the United States. Brebbia, C.A. and Popov, V., eds., *Air Pollution XVII: Proceedings of the Seventeenth International Conference on Modeling, Monitoring and Management of Air Pollution*. Lecture conducted from Tallinn, Estonia.

Rosenfeld, P. E. (October 15-18, 2007). Moss Point Community Exposure To Contaminants From A Releasing Facility. *The 23rd Annual International Conferences on Soils Sediment and Water*. Platform lecture conducted from University of Massachusetts, Amherst MA.

Rosenfeld, P. E. (October 15-18, 2007). The Repeated Trespass of Tritium-Contaminated Water Into A Surrounding Community Form Repeated Waste Spills From A Nuclear Power Plant. *The 23rd Annual International Conferences on Soils Sediment and Water*. Platform lecture conducted from University of Massachusetts, Amherst MA.

Rosenfeld, P. E. (October 15-18, 2007). Somerville Community Exposure To Contaminants From Wood Treatment Facility Emissions. The *23rd Annual International Conferences on Soils Sediment and Water*. Lecture conducted from University of Massachusetts, Amherst MA.

Rosenfeld P. E. (March 2007). Production, Chemical Properties, Toxicology, & Treatment Case Studies of 1,2,3-Trichloropropane (TCP). *The Association for Environmental Health and Sciences (AEHS) Annual Meeting*. Lecture conducted from San Diego, CA.

Rosenfeld P. E. (March 2007). Blood and Attic Sampling for Dioxin/Furan, PAH, and Metal Exposure in Florida, Alabama. *The AEHS Annual Meeting*. Lecture conducted from San Diego, CA.

Hensley A.R., Scott, A., **Rosenfeld P.E.**, Clark, J.J.J. (August 21 – 25, 2006). Dioxin Containing Attic Dust And Human Blood Samples Collected Near A Former Wood Treatment Facility. *The 26th International Symposium on Halogenated Persistent Organic Pollutants – DIOXIN2006*. Lecture conducted from Radisson SAS Scandinavia Hotel in Oslo Norway.

Hensley A.R., Scott, A., **Rosenfeld P.E.**, Clark, J.J.J. (November 4-8, 2006). Dioxin Containing Attic Dust And Human Blood Samples Collected Near A Former Wood Treatment Facility. *APHA 134 Annual Meeting & Exposition*. Lecture conducted from Boston Massachusetts.

Paul Rosenfeld Ph.D. (October 24-25, 2005). Fate, Transport and Persistence of PFOA and Related Chemicals. Mealey's C8/PFOA. *Science, Risk & Litigation Conference*. Lecture conducted from The Rittenhouse Hotel, Philadelphia, PA.

Paul Rosenfeld Ph.D. (September 19, 2005). Brominated Flame Retardants in Groundwater: Pathways to Human Ingestion, *Toxicology and Remediation PEMA Emerging Contaminant Conference*. Lecture conducted from Hilton Hotel, Irvine California.

Paul Rosenfeld Ph.D. (September 19, 2005). Fate, Transport, Toxicity, And Persistence of 1,2,3-TCP. *PEMA Emerging Contaminant Conference*. Lecture conducted from Hilton Hotel in Irvine, California.

Paul Rosenfeld Ph.D. (September 26-27, 2005). Fate, Transport and Persistence of PDBEs. *Mealey's Groundwater Conference*. Lecture conducted from Ritz Carlton Hotel, Marina Del Ray, California.

Paul Rosenfeld Ph.D. (June 7-8, 2005). Fate, Transport and Persistence of PFOA and Related Chemicals. *International Society of Environmental Forensics: Focus On Emerging Contaminants*. Lecture conducted from Sheraton Oceanfront Hotel, Virginia Beach, Virginia.

Paul Rosenfeld Ph.D. (July 21-22, 2005). Fate Transport, Persistence and Toxicology of PFOA and Related Perfluorochemicals. *2005 National Groundwater Association Ground Water And Environmental Law Conference*. Lecture conducted from Wyndham Baltimore Inner Harbor, Baltimore Maryland.

Paul Rosenfeld Ph.D. (July 21-22, 2005). Brominated Flame Retardants in Groundwater: Pathways to Human Ingestion, Toxicology and Remediation. *2005 National Groundwater Association Ground Water and Environmental Law Conference*. Lecture conducted from Wyndham Baltimore Inner Harbor, Baltimore Maryland.

Paul Rosenfeld, Ph.D. and James Clark Ph.D. and Rob Hesse R.G. (May 5-6, 2004). Tert-butyl Alcohol Liability and Toxicology, A National Problem and Unquantified Liability. *National Groundwater Association. Environmental Law Conference*. Lecture conducted from Congress Plaza Hotel, Chicago Illinois.

Paul Rosenfeld, Ph.D. (March 2004). Perchlorate Toxicology. *Meeting of the American Groundwater Trust*. Lecture conducted from Phoenix Arizona.

Hagemann, M.F., **Paul Rosenfeld, Ph.D.** and Rob Hesse (2004). Perchlorate Contamination of the Colorado River. *Meeting of tribal representatives*. Lecture conducted from Parker, AZ.

Paul Rosenfeld, Ph.D. (April 7, 2004). A National Damage Assessment Model For PCE and Dry Cleaners. *Drycleaner Symposium. California Ground Water Association*. Lecture conducted from Radison Hotel, Sacramento, California.

Rosenfeld, P. E., Grey, M., (June 2003) Two stage biofilter for biosolids composting odor control. *Seventh International In Situ And On Site Bioremediation Symposium Battelle Conference* Orlando, FL.

Paul Rosenfeld, Ph.D. and James Clark Ph.D. (February 20-21, 2003) Understanding Historical Use, Chemical Properties, Toxicity and Regulatory Guidance of 1,4 Dioxane. *National Groundwater Association. Southwest Focus Conference. Water Supply and Emerging Contaminants..* Lecture conducted from Hyatt Regency Phoenix Arizona.

Paul Rosenfeld, Ph.D. (February 6-7, 2003). Underground Storage Tank Litigation and Remediation. *California CUPA Forum*. Lecture conducted from Marriott Hotel, Anaheim California.

Paul Rosenfeld, Ph.D. (October 23, 2002) Underground Storage Tank Litigation and Remediation. *EPA Underground Storage Tank Roundtable*. Lecture conducted from Sacramento California.

Rosenfeld, P.E. and Suffet, M. (October 7- 10, 2002). Understanding Odor from Compost, *Wastewater and Industrial Processes. Sixth Annual Symposium On Off Flavors in the Aquatic Environment. International Water Association*. Lecture conducted from Barcelona Spain.

Rosenfeld, P.E. and Suffet, M. (October 7- 10, 2002). Using High Carbon Wood Ash to Control Compost Odor. *Sixth Annual Symposium On Off Flavors in the Aquatic Environment. International Water Association*. Lecture conducted from Barcelona Spain.

Rosenfeld, P.E. and Grey, M. A. (September 22-24, 2002). Biocycle Composting For Coastal Sage Restoration. *Northwest Biosolids Management Association*. Lecture conducted from Vancouver Washington..

Rosenfeld, P.E. and Grey, M. A. (November 11-14, 2002). Using High-Carbon Wood Ash to Control Odor at a Green Materials Composting Facility. *Soil Science Society Annual Conference*. Lecture conducted from Indianapolis, Maryland.

Rosenfeld, P.E. (September 16, 2000). Two stage biofilter for biosolids composting odor control. *Water Environment Federation*. Lecture conducted from Anaheim California.

Rosenfeld, P.E. (October 16, 2000). Wood ash and biofilter control of compost odor. *Biofest*. Lecture conducted from Ocean Shores, California.

Rosenfeld, P.E. (2000). Bioremediation Using Organic Soil Amendments. *California Resource Recovery Association*. Lecture conducted from Sacramento California.

Rosenfeld, P.E., C.L. Henry, R. Harrison. (1998). Oat and Grass Seed Germination and Nitrogen and Sulfur Emissions Following Biosolids Incorporation With High-Carbon Wood-Ash. *Water Environment Federation 12th Annual Residuals and Biosolids Management Conference Proceedings*. Lecture conducted from Bellevue Washington.

Rosenfeld, P.E., and C.L. Henry. (1999). An evaluation of ash incorporation with biosolids for odor reduction. *Soil Science Society of America*. Lecture conducted from Salt Lake City Utah.

Rosenfeld, P.E., C.L. Henry, R. Harrison. (1998). Comparison of Microbial Activity and Odor Emissions from Three Different Biosolids Applied to Forest Soil. *Brown and Caldwell*. Lecture conducted from Seattle Washington.

Rosenfeld, P.E., C.L. Henry. (1998). Characterization, Quantification, and Control of Odor Emissions from Biosolids Application To Forest Soil. *Biofest*. Lecture conducted from Lake Chelan, Washington.

Rosenfeld, P.E., C.L. Henry, R. Harrison. (1998). Oat and Grass Seed Germination and Nitrogen and Sulfur Emissions Following Biosolids Incorporation With High-Carbon Wood-Ash. Water Environment Federation 12th Annual Residuals and Biosolids Management Conference Proceedings. Lecture conducted from Bellevue Washington.

Rosenfeld, P.E., C.L. Henry, R. B. Harrison, and R. Dills. (1997). Comparison of Odor Emissions From Three Different Biosolids Applied to Forest Soil. *Soil Science Society of America*. Lecture conducted from Anaheim California.

Teaching Experience:

UCLA Department of Environmental Health (Summer 2003 through 20010) Taught Environmental Health Science 100 to students, including undergrad, medical doctors, public health professionals and nurses. Course focused on the health effects of environmental contaminants.

National Ground Water Association, Successful Remediation Technologies. Custom Course in Sante Fe, New Mexico. May 21, 2002. Focused on fate and transport of fuel contaminants associated with underground storage tanks.

National Ground Water Association; Successful Remediation Technologies Course in Chicago Illinois. April 1, 2002. Focused on fate and transport of contaminants associated with Superfund and RCRA sites.

California Integrated Waste Management Board, April and May, 2001. Alternative Landfill Caps Seminar in San Diego, Ventura, and San Francisco. Focused on both prescriptive and innovative landfill cover design.

UCLA Department of Environmental Engineering, February 5, 2002. Seminar on Successful Remediation Technologies focusing on Groundwater Remediation.

University Of Washington, Soil Science Program, Teaching Assistant for several courses including: Soil Chemistry, Organic Soil Amendments, and Soil Stability.

U.C. Berkeley, Environmental Science Program Teaching Assistant for Environmental Science 10.

Academic Grants Awarded:

California Integrated Waste Management Board. \$41,000 grant awarded to UCLA Institute of the Environment. Goal: To investigate effect of high carbon wood ash on volatile organic emissions from compost. 2001.

Synagro Technologies, Corona California: \$10,000 grant awarded to San Diego State University. Goal: investigate effect of biosolids for restoration and remediation of degraded coastal sage soils. 2000.

King County, Department of Research and Technology, Washington State. \$100,000 grant awarded to University of Washington: Goal: To investigate odor emissions from biosolids application and the effect of polymers and ash on VOC emissions. 1998.

Northwest Biosolids Management Association, Washington State. \$20,000 grant awarded to investigate effect of polymers and ash on VOC emissions from biosolids. 1997.

James River Corporation, Oregon: \$10,000 grant was awarded to investigate the success of genetically engineered Poplar trees with resistance to round-up. 1996.

United State Forest Service, Tahoe National Forest: \$15,000 grant was awarded to investigating fire ecology of the Tahoe National Forest. 1995.

Kellogg Foundation, Washington D.C. \$500 grant was awarded to construct a large anaerobic digester on St. Kitts in West Indies. 1993

Deposition and/or Trial Testimony:

In the United States District Court For The District of New Jersey

Duarte et al, *Plaintiffs*, vs. United States Metals Refining Company et. al. *Defendant*.

Case No.: 2:17-cv-01624-ES-SCM

Rosenfeld Deposition. 6-7-2019

In the United States District Court of Southern District of Texas Galveston Division

M/T Carla Maersk, *Plaintiffs*, vs. Conti 168., Schiffahrts-GMBH & Co. Bulker KG MS “Conti Perdido”
Defendant.

Case No.: 3:15-CV-00106 consolidated with 3:15-CV-00237

Rosenfeld Deposition. 5-9-2019

In The Superior Court of the State of California In And For The County Of Los Angeles – Santa Monica

Carole-Taddeo-Bates et al., vs. Ifran Khan et al., Defendants

Case No.: No. BC615636

Rosenfeld Deposition, 1-26-2019

In The Superior Court of the State of California In And For The County Of Los Angeles – Santa Monica

The San Gabriel Valley Council of Governments et al. vs El Adobe Apts. Inc. et al., Defendants

Case No.: No. BC646857

Rosenfeld Deposition, 10-6-2018; Trial 3-7-19

In United States District Court For The District of Colorado

Bells et al. Plaintiff vs. The 3M Company et al., Defendants

Case: No 1:16-cv-02531-RBJ

Rosenfeld Deposition, 3-15-2018 and 4-3-2018

In The District Court Of Regan County, Texas, 112th Judicial District

Phillip Bales et al., Plaintiff vs. Dow Agrosiences, LLC, et al., Defendants

Cause No 1923

Rosenfeld Deposition, 11-17-2017

In The Superior Court of the State of California In And For The County Of Contra Costa

Simons et al., Plaintiffs vs. Chevron Corporation, et al., Defendants

Cause No C12-01481

Rosenfeld Deposition, 11-20-2017

In The Circuit Court Of The Twentieth Judicial Circuit, St Clair County, Illinois

Martha Custer et al., Plaintiff vs. Cerro Flow Products, Inc., Defendants

Case No.: No. 0i9-L-2295

Rosenfeld Deposition, 8-23-2017

In The Superior Court of the State of California, For The County of Los Angeles

Warrn Gilbert and Penny Gilber, Plaintiff vs. BMW of North America LLC

Case No.: LC102019 (c/w BC582154)

Rosenfeld Deposition, 8-16-2017, Trail 8-28-2018

In the Northern District Court of Mississippi, Greenville Division

Brenda J. Cooper, et al., *Plaintiffs*, vs. Meritor Inc., et al., *Defendants*

Case Number: 4:16-cv-52-DMB-JVM

Rosenfeld Deposition: July 2017

In The Superior Court of the State of Washington, County of Snohomish
Michael Davis and Julie Davis et al., Plaintiff vs. Cedar Grove Composting Inc., Defendants
Case No.: No. 13-2-03987-5
Rosenfeld Deposition, February 2017
Trial, March 2017

In The Superior Court of the State of California, County of Alameda
Charles Spain., Plaintiff vs. Thermo Fisher Scientific, et al., Defendants
Case No.: RG14711115
Rosenfeld Deposition, September 2015

In The Iowa District Court In And For Poweshiek County
Russell D. Winburn, et al., Plaintiffs vs. Doug Hoksbergen, et al., Defendants
Case No.: LALA002187
Rosenfeld Deposition, August 2015

In The Iowa District Court For Wapello County
Jerry Dovico, et al., Plaintiffs vs. Valley View Sine LLC, et al., Defendants
Law No.: LALA105144 - Division A
Rosenfeld Deposition, August 2015

In The Iowa District Court For Wapello County
Doug Pauls, et al., et al., Plaintiffs vs. Richard Warren, et al., Defendants
Law No.: LALA105144 - Division A
Rosenfeld Deposition, August 2015

In The Circuit Court of Ohio County, West Virginia
Robert Andrews, et al. v. Antero, et al.
Civil Action NO. 14-C-30000
Rosenfeld Deposition, June 2015

In The Third Judicial District County of Dona Ana, New Mexico
Betty Gonzalez, et al. Plaintiffs vs. Del Oro Dairy, Del Oro Real Estate LLC, Jerry Settles and Deward
DeRuyter, Defendants
Rosenfeld Deposition: July 2015

In The Iowa District Court For Muscatine County
Laurie Freeman et. al. Plaintiffs vs. Grain Processing Corporation, Defendant
Case No 4980
Rosenfeld Deposition: May 2015

In the Circuit Court of the 17th Judicial Circuit, in and For Broward County, Florida
Walter Hinton, et. al. Plaintiff, vs. City of Fort Lauderdale, Florida, a Municipality, Defendant.
Case Number CACE07030358 (26)
Rosenfeld Deposition: December 2014

In the United States District Court Western District of Oklahoma
Tommy McCarty, et al., Plaintiffs, v. Oklahoma City Landfill, LLC d/b/a Southeast Oklahoma City
Landfill, et al. Defendants.
Case No. 5:12-cv-01152-C
Rosenfeld Deposition: July 2014

In the County Court of Dallas County Texas
Lisa Parr et al, *Plaintiff*, vs. Aruba et al, *Defendant*.
Case Number cc-11-01650-E
Rosenfeld Deposition: March and September 2013
Rosenfeld Trial: April 2014

In the Court of Common Pleas of Tuscarawas County Ohio
John Michael Abicht, et al., *Plaintiffs*, vs. Republic Services, Inc., et al., *Defendants*
Case Number: 2008 CT 10 0741 (Cons. w/ 2009 CV 10 0987)
Rosenfeld Deposition: October 2012

In the United States District Court of Southern District of Texas Galveston Division
Kyle Cannon, Eugene Donovan, Genaro Ramirez, Carol Sassler, and Harvey Walton, each Individually and on behalf of those similarly situated, *Plaintiffs*, vs. BP Products North America, Inc., *Defendant*.
Case 3:10-cv-00622
Rosenfeld Deposition: February 2012
Rosenfeld Trial: April 2013

In the Circuit Court of Baltimore County Maryland
Philip E. Cvach, II et al., *Plaintiffs* vs. Two Farms, Inc. d/b/a Royal Farms, Defendants
Case Number: 03-C-12-012487 OT
Rosenfeld Deposition: September 2013

EXHIBIT C



1640 5th St., Suite 204 Santa
Santa Monica, California 90401
Tel: (949) 887-9013
Email: mhagemann@swape.com

Matthew F. Hagemann, P.G., C.Hg., QSD, QSP

**Geologic and Hydrogeologic Characterization
Industrial Stormwater Compliance
Investigation and Remediation Strategies
Litigation Support and Testifying Expert
CEQA Review**

Education:

M.S. Degree, Geology, California State University Los Angeles, Los Angeles, CA, 1984.

B.A. Degree, Geology, Humboldt State University, Arcata, CA, 1982.

Professional Certifications:

California Professional Geologist

California Certified Hydrogeologist

Qualified SWPPP Developer and Practitioner

Professional Experience:

Matt has 25 years of experience in environmental policy, assessment and remediation. He spent nine years with the U.S. EPA in the RCRA and Superfund programs and served as EPA's Senior Science Policy Advisor in the Western Regional Office where he identified emerging threats to groundwater from perchlorate and MTBE. While with EPA, Matt also served as a Senior Hydrogeologist in the oversight of the assessment of seven major military facilities undergoing base closure. He led numerous enforcement actions under provisions of the Resource Conservation and Recovery Act (RCRA) while also working with permit holders to improve hydrogeologic characterization and water quality monitoring.

Matt has worked closely with U.S. EPA legal counsel and the technical staff of several states in the application and enforcement of RCRA, Safe Drinking Water Act and Clean Water Act regulations. Matt has trained the technical staff in the States of California, Hawaii, Nevada, Arizona and the Territory of Guam in the conduct of investigations, groundwater fundamentals, and sampling techniques.

Positions Matt has held include:

- Founding Partner, Soil/Water/Air Protection Enterprise (SWAPE) (2003 – present);
- Geology Instructor, Golden West College, 2010 – 2014;
- Senior Environmental Analyst, Komex H2O Science, Inc. (2000 -- 2003);

- Executive Director, Orange Coast Watch (2001 – 2004);
- Senior Science Policy Advisor and Hydrogeologist, U.S. Environmental Protection Agency (1989–1998);
- Hydrogeologist, National Park Service, Water Resources Division (1998 – 2000);
- Adjunct Faculty Member, San Francisco State University, Department of Geosciences (1993 – 1998);
- Instructor, College of Marin, Department of Science (1990 – 1995);
- Geologist, U.S. Forest Service (1986 – 1998); and
- Geologist, Dames & Moore (1984 – 1986).

Senior Regulatory and Litigation Support Analyst:

With SWAPE, Matt’s responsibilities have included:

- Lead analyst and testifying expert in the review of over 100 environmental impact reports since 2003 under CEQA that identify significant issues with regard to hazardous waste, water resources, water quality, air quality, Valley Fever, greenhouse gas emissions, and geologic hazards. Make recommendations for additional mitigation measures to lead agencies at the local and county level to include additional characterization of health risks and implementation of protective measures to reduce worker exposure to hazards from toxins and Valley Fever.
- Stormwater analysis, sampling and best management practice evaluation at industrial facilities.
- Manager of a project to provide technical assistance to a community adjacent to a former Naval shipyard under a grant from the U.S. EPA.
- Technical assistance and litigation support for vapor intrusion concerns.
- Lead analyst and testifying expert in the review of environmental issues in license applications for large solar power plants before the California Energy Commission.
- Manager of a project to evaluate numerous formerly used military sites in the western U.S.
- Manager of a comprehensive evaluation of potential sources of perchlorate contamination in Southern California drinking water wells.
- Manager and designated expert for litigation support under provisions of Proposition 65 in the review of releases of gasoline to sources drinking water at major refineries and hundreds of gas stations throughout California.
- Expert witness on two cases involving MTBE litigation.
- Expert witness and litigation support on the impact of air toxins and hazards at a school.
- Expert witness in litigation at a former plywood plant.

With Komex H2O Science Inc., Matt’s duties included the following:

- Senior author of a report on the extent of perchlorate contamination that was used in testimony by the former U.S. EPA Administrator and General Counsel.
- Senior researcher in the development of a comprehensive, electronically interactive chronology of MTBE use, research, and regulation.
- Senior researcher in the development of a comprehensive, electronically interactive chronology of perchlorate use, research, and regulation.
- Senior researcher in a study that estimates nationwide costs for MTBE remediation and drinking water treatment, results of which were published in newspapers nationwide and in testimony against provisions of an energy bill that would limit liability for oil companies.
- Research to support litigation to restore drinking water supplies that have been contaminated by MTBE in California and New York.

- Expert witness testimony in a case of oil production-related contamination in Mississippi.
- Lead author for a multi-volume remedial investigation report for an operating school in Los Angeles that met strict regulatory requirements and rigorous deadlines.

- Development of strategic approaches for cleanup of contaminated sites in consultation with clients and regulators.

Executive Director:

As Executive Director with Orange Coast Watch, Matt led efforts to restore water quality at Orange County beaches from multiple sources of contamination including urban runoff and the discharge of wastewater. In reporting to a Board of Directors that included representatives from leading Orange County universities and businesses, Matt prepared issue papers in the areas of treatment and disinfection of wastewater and control of the discharge of grease to sewer systems. Matt actively participated in the development of countywide water quality permits for the control of urban runoff and permits for the discharge of wastewater. Matt worked with other nonprofits to protect and restore water quality, including Surfrider, Natural Resources Defense Council and Orange County CoastKeeper as well as with business institutions including the Orange County Business Council.

Hydrogeology:

As a Senior Hydrogeologist with the U.S. Environmental Protection Agency, Matt led investigations to characterize and cleanup closing military bases, including Mare Island Naval Shipyard, Hunters Point Naval Shipyard, Treasure Island Naval Station, Alameda Naval Station, Moffett Field, Mather Army Airfield, and Sacramento Army Depot. Specific activities were as follows:

- Led efforts to model groundwater flow and contaminant transport, ensured adequacy of monitoring networks, and assessed cleanup alternatives for contaminated sediment, soil, and groundwater.
- Initiated a regional program for evaluation of groundwater sampling practices and laboratory analysis at military bases.
- Identified emerging issues, wrote technical guidance, and assisted in policy and regulation development through work on four national U.S. EPA workgroups, including the Superfund Groundwater Technical Forum and the Federal Facilities Forum.

At the request of the State of Hawaii, Matt developed a methodology to determine the vulnerability of groundwater to contamination on the islands of Maui and Oahu. He used analytical models and a GIS to show zones of vulnerability, and the results were adopted and published by the State of Hawaii and County of Maui.

As a hydrogeologist with the EPA Groundwater Protection Section, Matt worked with provisions of the Safe Drinking Water Act and NEPA to prevent drinking water contamination. Specific activities included the following:

- Received an EPA Bronze Medal for his contribution to the development of national guidance for the protection of drinking water.
- Managed the Sole Source Aquifer Program and protected the drinking water of two communities through designation under the Safe Drinking Water Act. He prepared geologic reports, conducted public hearings, and responded to public comments from residents who were very concerned about the impact of designation.

- Reviewed a number of Environmental Impact Statements for planned major developments, including large hazardous and solid waste disposal facilities, mine reclamation, and water transfer.

Matt served as a hydrogeologist with the RCRA Hazardous Waste program. Duties were as follows:

- Supervised the hydrogeologic investigation of hazardous waste sites to determine compliance with Subtitle C requirements.
- Reviewed and wrote "part B" permits for the disposal of hazardous waste.
- Conducted RCRA Corrective Action investigations of waste sites and led inspections that formed the basis for significant enforcement actions that were developed in close coordination with U.S. EPA legal counsel.
- Wrote contract specifications and supervised contractor's investigations of waste sites.

With the National Park Service, Matt directed service-wide investigations of contaminant sources to prevent degradation of water quality, including the following tasks:

- Applied pertinent laws and regulations including CERCLA, RCRA, NEPA, NRDA, and the Clean Water Act to control military, mining, and landfill contaminants.
- Conducted watershed-scale investigations of contaminants at parks, including Yellowstone and Olympic National Park.
- Identified high-levels of perchlorate in soil adjacent to a national park in New Mexico and advised park superintendent on appropriate response actions under CERCLA.
- Served as a Park Service representative on the Interagency Perchlorate Steering Committee, a national workgroup.
- Developed a program to conduct environmental compliance audits of all National Parks while serving on a national workgroup.
- Co-authored two papers on the potential for water contamination from the operation of personal watercraft and snowmobiles, these papers serving as the basis for the development of nation-wide policy on the use of these vehicles in National Parks.
- Contributed to the Federal Multi-Agency Source Water Agreement under the Clean Water Action Plan.

Policy:

Served senior management as the Senior Science Policy Advisor with the U.S. Environmental Protection Agency, Region 9. Activities included the following:

- Advised the Regional Administrator and senior management on emerging issues such as the potential for the gasoline additive MTBE and ammonium perchlorate to contaminate drinking water supplies.
- Shaped EPA's national response to these threats by serving on workgroups and by contributing to guidance, including the Office of Research and Development publication, *Oxygenates in Water: Critical Information and Research Needs*.
- Improved the technical training of EPA's scientific and engineering staff.
- Earned an EPA Bronze Medal for representing the region's 300 scientists and engineers in negotiations with the Administrator and senior management to better integrate scientific principles into the policy-making process.
- Established national protocol for the peer review of scientific documents.

Geology:

With the U.S. Forest Service, Matt led investigations to determine hillslope stability of areas proposed for timber harvest in the central Oregon Coast Range. Specific activities were as follows:

- Mapped geology in the field, and used aerial photographic interpretation and mathematical models to determine slope stability.
- Coordinated his research with community members who were concerned with natural resource protection.
- Characterized the geology of an aquifer that serves as the sole source of drinking water for the city of Medford, Oregon.

As a consultant with Dames and Moore, Matt led geologic investigations of two contaminated sites (later listed on the Superfund NPL) in the Portland, Oregon, area and a large hazardous waste site in eastern Oregon. Duties included the following:

- Supervised year-long effort for soil and groundwater sampling.
- Conducted aquifer tests.
- Investigated active faults beneath sites proposed for hazardous waste disposal.

Teaching:

From 1990 to 1998, Matt taught at least one course per semester at the community college and university levels:

- At San Francisco State University, held an adjunct faculty position and taught courses in environmental geology, oceanography (lab and lecture), hydrogeology, and groundwater contamination.
- Served as a committee member for graduate and undergraduate students.
- Taught courses in environmental geology and oceanography at the College of Marin.

Matt taught physical geology (lecture and lab and introductory geology at Golden West College in Huntington Beach, California from 2010 to 2014.

Invited Testimony, Reports, Papers and Presentations:

Hagemann, M.F., 2008. Disclosure of Hazardous Waste Issues under CEQA. Presentation to the Public Environmental Law Conference, Eugene, Oregon.

Hagemann, M.F., 2008. Disclosure of Hazardous Waste Issues under CEQA. Invited presentation to U.S. EPA Region 9, San Francisco, California.

Hagemann, M.F., 2005. Use of Electronic Databases in Environmental Regulation, Policy Making and Public Participation. Brownfields 2005, Denver, Colorado.

Hagemann, M.F., 2004. Perchlorate Contamination of the Colorado River and Impacts to Drinking Water in Nevada and the Southwestern U.S. Presentation to a meeting of the American Groundwater Trust, Las Vegas, NV (served on conference organizing committee).

Hagemann, M.F., 2004. Invited testimony to a California Senate committee hearing on air toxins at schools in Southern California, Los Angeles.

Brown, A., Farrow, J., Gray, A. and **Hagemann, M.**, 2004. An Estimate of Costs to Address MTBE Releases from Underground Storage Tanks and the Resulting Impact to Drinking Water Wells. Presentation to the Ground Water and Environmental Law Conference, National Groundwater Association.

Hagemann, M.F., 2004. Perchlorate Contamination of the Colorado River and Impacts to Drinking Water in Arizona and the Southwestern U.S. Presentation to a meeting of the American Groundwater Trust, Phoenix, AZ (served on conference organizing committee).

Hagemann, M.F., 2003. Perchlorate Contamination of the Colorado River and Impacts to Drinking Water in the Southwestern U.S. Invited presentation to a special committee meeting of the National Academy of Sciences, Irvine, CA.

Hagemann, M.F., 2003. Perchlorate Contamination of the Colorado River. Invited presentation to a tribal EPA meeting, Pechanga, CA.

Hagemann, M.F., 2003. Perchlorate Contamination of the Colorado River. Invited presentation to a meeting of tribal representatives, Parker, AZ.

Hagemann, M.F., 2003. Impact of Perchlorate on the Colorado River and Associated Drinking Water Supplies. Invited presentation to the Inter-Tribal Meeting, Torres Martinez Tribe.

Hagemann, M.F., 2003. The Emergence of Perchlorate as a Widespread Drinking Water Contaminant. Invited presentation to the U.S. EPA Region 9.

Hagemann, M.F., 2003. A Deductive Approach to the Assessment of Perchlorate Contamination. Invited presentation to the California Assembly Natural Resources Committee.

Hagemann, M.F., 2003. Perchlorate: A Cold War Legacy in Drinking Water. Presentation to a meeting of the National Groundwater Association.

Hagemann, M.F., 2002. From Tank to Tap: A Chronology of MTBE in Groundwater. Presentation to a meeting of the National Groundwater Association.

Hagemann, M.F., 2002. A Chronology of MTBE in Groundwater and an Estimate of Costs to Address Impacts to Groundwater. Presentation to the annual meeting of the Society of Environmental Journalists.

Hagemann, M.F., 2002. An Estimate of the Cost to Address MTBE Contamination in Groundwater (and Who Will Pay). Presentation to a meeting of the National Groundwater Association.

Hagemann, M.F., 2002. An Estimate of Costs to Address MTBE Releases from Underground Storage Tanks and the Resulting Impact to Drinking Water Wells. Presentation to a meeting of the U.S. EPA and State Underground Storage Tank Program managers.

Hagemann, M.F., 2001. From Tank to Tap: A Chronology of MTBE in Groundwater. Unpublished report.

Hagemann, M.F., 2001. Estimated Cleanup Cost for MTBE in Groundwater Used as Drinking Water. Unpublished report.

Hagemann, M.F., 2001. Estimated Costs to Address MTBE Releases from Leaking Underground Storage Tanks. Unpublished report.

Hagemann, M.F., and VanMouwerik, M., 1999. Potential Water Quality Concerns Related to Snowmobile Usage. Water Resources Division, National Park Service, Technical Report.

VanMouwerik, M. and **Hagemann, M.F.** 1999, Water Quality Concerns Related to Personal Watercraft Usage. Water Resources Division, National Park Service, Technical Report.

Hagemann, M.F., 1999, Is Dilution the Solution to Pollution in National Parks? The George Wright Society Biannual Meeting, Asheville, North Carolina.

Hagemann, M.F., 1997, The Potential for MTBE to Contaminate Groundwater. U.S. EPA Superfund Groundwater Technical Forum Annual Meeting, Las Vegas, Nevada.

Hagemann, M.F., and Gill, M., 1996, Impediments to Intrinsic Remediation, Moffett Field Naval Air Station, Conference on Intrinsic Remediation of Chlorinated Hydrocarbons, Salt Lake City.

Hagemann, M.F., Fukunaga, G.L., 1996, The Vulnerability of Groundwater to Anthropogenic Contaminants on the Island of Maui, Hawaii. Hawaii Water Works Association Annual Meeting, Maui, October 1996.

Hagemann, M. F., Fukanaga, G. L., 1996, Ranking Groundwater Vulnerability in Central Oahu, Hawaii. Proceedings, Geographic Information Systems in Environmental Resources Management, Air and Waste Management Association Publication VIP-61.

Hagemann, M.F., 1994. Groundwater Characterization and Cleanup at Closing Military Bases in California. Proceedings, California Groundwater Resources Association Meeting.

Hagemann, M.F. and Sabol, M.A., 1993. Role of the U.S. EPA in the High Plains States Groundwater Recharge Demonstration Program. Proceedings, Sixth Biennial Symposium on the Artificial Recharge of Groundwater.

Hagemann, M.F., 1993. U.S. EPA Policy on the Technical Impracticability of the Cleanup of DNAPL-contaminated Groundwater. California Groundwater Resources Association Meeting.

Hagemann, M.F., 1992. Dense Nonaqueous Phase Liquid Contamination of Groundwater: An Ounce of Prevention... Proceedings, Association of Engineering Geologists Annual Meeting, v. 35.

Other Experience:

Selected as subject matter expert for the California Professional Geologist licensing examination, 2009-2011.

Los Angeles Department of Building and Safety

Certificate Information: 1200 N VINE ST 90038

Application / Permit	22010-10000-05021
Plan Check / Job No.	B22LA20609
Group	Building
Type	Bldg-New
Sub-Type	Commercial
Primary Use	(5) Apartment
Work Description	**** HSAP TO CHECK FOR ZONING REQUIREMENTS ONLY - (SB330) **** NEW 7 STORY 151 UNITS (11% AFFORDABLE 17UNITS) MIXED USE AFFORDABLE HOUSING APARTMENT TO INCLUDE 5 STORY TYPE IIIA APARTMENT OVER 1 STORY TYPE IA APARTMENT/PARKING OVER 1 STORY TYPE IA RETAIL/PARKING, 12.22.A.25 / AB2345 WITH ADDITIONAL INCENTIVE
Permit Issued	No
Current Status	Verifications in Progress on 12/27/2022

Permit Application Status History

Submitted	10/13/2022	APPLICANT
Assigned to Plan Check Engineer	10/20/2022	ARMEN JIVALAGIAN
Corrections Issued	10/24/2022	ARMEN JIVALAGIAN
Reviewed by Supervisor	11/15/2022	MINYE PAK
Applicant returned to address corrections	12/21/2022	ARMEN JIVALAGIAN
Applicant returned to address corrections	12/27/2022	ARMEN JIVALAGIAN

Permit Application Clearance Information

"D" conditions	Not Cleared	10/24/2022	City Planning Department
Address approval	Not Cleared	10/24/2022	Bureau of Engineering
Bicycle Parking	Not Cleared	10/24/2022	Bureau of Engineering
Building over 36-ft	Not Cleared	10/24/2022	Cal Occ. Safety and Health Administration
CPC	Not Cleared	10/24/2022	City Planning Department
Construction near power lines	Not Cleared	10/24/2022	Department of Water and Power
Construction within easement	Not Cleared	10/24/2022	Department of Water and Power
DAS Clearance	Not Cleared	10/24/2022	Department of Building and Safety
DCP conditions approval	Not Cleared	10/24/2022	Los Angeles Housing Department
Density Bonus	Not Cleared	10/24/2022	Los Angeles Housing Department
Driveway location	Not Cleared	10/24/2022	Department of Transportation
Encroachment in public way	Not Cleared	10/24/2022	Bureau of Engineering
Eng Process Fee Ord 176,300	Not Cleared	10/24/2022	Bureau of Engineering
Excavation more than 5-ft deep	Not Cleared	10/24/2022	Cal Occ. Safety and Health Administration
Fire Marshal Fire Life Safety	Not Cleared	10/24/2022	Los Angeles Fire Department
Green Code	Not Cleared	10/24/2022	Department of Building and Safety
Highway dedication	Not Cleared	10/24/2022	Bureau of Engineering
Hydrant and Access approval	Not Cleared	10/24/2022	Los Angeles Fire Department
Internal circulation	Not Cleared	10/24/2022	Department of Transportation
Low Impact Development	Not Cleared	10/24/2022	Bureau of Sanitation
Opn space landscape/Water mgmt	Not Cleared	10/24/2022	City Planning Department

Permit	Not Cleared	10/24/2022	Bureau of Engineering
Roof/Waste drainage to street	Not Cleared	10/24/2022	Bureau of Engineering
Sewer availability	Not Cleared	10/24/2022	Bureau of Engineering
Site Plan review	Not Cleared	10/24/2022	City Planning Department
Trees in Parkway	Not Cleared	10/24/2022	Bureau of Street Services
Work Adjacent to Public Way	Not Cleared	10/24/2022	Bureau of Engineering
ZA Case	Not Cleared	10/24/2022	City Planning Department
ZA Case	Not Cleared	10/24/2022	City Planning Department
ZA Case	Not Cleared	10/24/2022	City Planning Department
ZI	Not Cleared	10/24/2022	City Planning Department

Contact Information

No Data Available.

Inspector Information

No Data Available.

Pending Inspections

No Data Available.

Inspection Request History

No Data Available.

**Exhibit F –
CAJA Environmental
Services Response Letter
to CEQA Comments, April
13, 2023**



9410 Topanga Canyon Boulevard, Suite 101
Chatsworth, CA 91311
Phone 310-469-6700

April 13, 2023

Los Angeles Department of City Planning
City Planning Commission
Email: cpc@lacity.org

Responses to Comments re: 1200 Vine Project (Project)

We write in response to the comment letters received on the 1200 Vine Project (CPC-2022-7047-CU-DB-SPR-HCA) (ENV-2022-7048-CE), which included a Class 32 (Infill) Categorical Exemption pursuant to the California Environmental Quality Act (CEQA).

The Project Site is located on the northeast corner of Vine Street and Lexington Avenue, in the Hollywood Community Plan of the City of Los Angeles, 90038 in the County of Los Angeles. The Project Site contains two buildings with a total of 27,011 square feet. Both buildings are vacant. The Project would construct a new mixed-use 8-story building with 153 residential dwelling units and 7,000 square feet of ground floor commercial (assuming a high-turnover sit-down restaurant with 235 seats).

The following comment letters were received:

- Mitchell M. Tsai Law Firm representing the Southwest Mountain States Regional Council of Carpenters (SWMSRCC), dated February 7, 2023
- Lozeau Drury Law Firm representing the Supporters Alliance for Environmental Responsibility (SAFER), dated February 7, 2023

While the comment letters challenge the Project's approval, they only makes generic arguments that do not address the Project or the CE. The comment letters, in fact, lack any evidence whatsoever in support of their generalized claims of CEQA violations.

SWMSRCC, February 7, 2023

SWMSRCC Comment 1

The city should require the use of a local workforce to benefit the community's economic development and environment.

Response to SWMSRCC Comment 1

The comment does not state a specific concern or question regarding the adequacy of the CE in identifying and analyzing the environmental impacts of the Project, nor does the comment identify any physical environmental impacts caused by the Project. Therefore, this comment does not require a detailed response. (CEQA Guidelines, § 15088(c); *Citizens for East Shore Parks v. State Lands Comm'n* (2011) 202 Cal.App.4th 549.)

SWMSRCC Comment 2

The city should impose training requirements for the project's construction activities to prevent community spread of Covid-19 and other infectious diseases.

Response to SWMSRCC Comment 1

The comment does not state a specific concern or question regarding the adequacy of the CE in identifying and analyzing the environmental impacts of the Project, nor does the comment identify any physical environmental impacts caused by the Project. Therefore, this comment does not require a detailed response. (CEQA Guidelines, § 15088(c); *Citizens for East Shore Parks v. State Lands Comm'n* (2011) 202 Cal.App.4th 549.)

SAFER Comment 1

There is Substantial Evidence that the Project May Have a Significant Health Risk Impact from Indoor Air Quality Impacts, Therefore the Categorical Exemption Does Not Apply.

Response to SAFER Comment 1

The SAFER Letter includes an analysis asserting that the Project would result in significant impacts from construction materials and furniture that would allegedly release formaldehyde and cause significant indoor air quality impacts. First, the SAFER Letter ignores the substantial evidence in record supporting the conclusion that the Project would not result in significant Toxic Air Contaminant (TAC) impacts, found at pages 2-78 through 2-81 of the CE. As set forth on pages 2-74 to 2-78 of the CE, and supported by Project-specific CalEEMod modeling included as Appendix E to the CE (Air Quality Technical Modeling, DKA Planning, October 2022), the Project's construction and operation would not generate emissions that exceed South Coast Air Quality Management District (SCAQMD) significance thresholds for air quality.

Further, the SAFER Letter analysis of alleged formaldehyde impacts is not based on any factual data concerning the Project, but relies entirely on speculation. The analysis is based on speculation regarding the type of furniture to be used by future residents and the construction materials that would be utilized to build the Project. The analysis is based on the speculation that the Project would utilize unspecified "composite wood products" indoors with no evidentiary support specific to the Project. Moreover, the SAFER Letter purported indoor air quality analysis relies on an unsubstantiated indoor air quality "threshold" not adopted by the City, SCAQMD, or any other responsible agency for this Project.

The speculation which forms the basis of the SAFER analysis includes inappropriate factors, including the impact of existing outdoor air quality on future Project residents (which is not a recognizable CEQA impact of the Project on the environment) and assumptions such as construction workers on the Project being exposed to formaldehyde for 45 years. There is no analysis specific to the Project, but rather generalized conclusions of formaldehyde exposure in the existing environment.

In fact, the Project CE includes an air quality technical analysis that is fully compliant with CEQA in its focus on regional and localized impacts from emissions of criteria pollutants and other relevant air quality concerns, including potential emissions of TACs related to outdoor air quality. This scope of analysis is appropriate in light of CEQA's general focus on projects' potential impacts on the human environment in general and not future project users.¹ In furtherance of this scope and general focus of CEQA analyses, the State's CEQA Guidelines require CEQA-compliant air quality impacts analyses to assess the impacts a project would have on *outdoor* air quality, directing air quality analyses to address whether a project would conflict with or obstruct implementation of the applicable air quality plan, contribute to an existing air quality violation, or result in a cumulatively considerable increase in a criteria pollutant for which the region is in non-attainment, among other similar relevant factors.² Indoor air quality is not regulated by the applicable air quality plan, the SCAQMD's 2022 Air Quality Management Plan (AQMP). The USEPA, the California Air Resources Board (CARB) and SCAQMD have also not promulgated ambient air quality standards for indoor air quality.

¹ California Building Industry Association v. Bay Area Air Quality Management District (2015) 62 Cal.4th 369, 377 ("In light of CEQA's text, statutory structure, and purpose, we conclude that agencies subject to CEQA generally are not required to analyze the impact of existing environmental conditions on a project's future users or residents.")

² See CEQA Guidelines, Appendix G.

Furthermore, to address indoor air quality, the Project would comply with all applicable regulations designed to address indoor air quality and potential toxic materials. These include the California Green Building Standards Code (CALGreen)³, applicable to new buildings, which is designed to promote “environmentally responsible, cost-effective, healthier places to live and work.” “CALGreen includes both required measures and voluntary measures, a number of which help assure healthful indoor air quality, such as those addressing chemical emissions from composite wood products, carpets, resilient flooring materials, paints, adhesives, sealants, and insulation, and also ventilation.”

More specifically, Section 4.5, Environmental Quality, of CALGreen provides mandatory residential measures to reduce the quantity of air contaminants that are odorous, irritating and/or harmful to the comfort and wellbeing of a building’s installers, occupants and neighbors. It includes VOC limits for paints, coatings, adhesives, adhesive bonding primers, sealants, sealant primers, and caulk. Section 4.504.3, Carpet Systems, of CALGreen establishes product requirements to meet one of the following: (1) Carpet and Rug Institute’s Green Label Plus Program; (2) California Department of Public Health, “Standard Method for the Testing and Evaluation of Volatile Organic Chemical Emissions from Indoor Sources Using Environmental Chambers,” Version 1.1; (3) NSF/ANSI 140 at the Gold Level; or (4) Scientific Certifications Systems Indoor Advantage Gold. Furthermore, Section 4.504.5, Composite Wood Products, of CALGreen establishes limits for formaldehyde as specified in ARBS’s Air Toxics Control Measure for Composite Wood (e.g., particle board). These measures have been established through CALGreen and are designed to reduce the quantity of air contaminants to acceptable levels.

CARB’s ATCM (Airborne Toxic Control Measure to Reduce Formaldehyde Emissions from Composite Wood Products) is a regulation that has a purpose of “reducing formaldehyde emissions from composite wood products, and finished goods that contain composite wood products, that are sold, offered for sale, supplied, used, or manufactured for sale in California. The composite wood products covered by this regulation are hardwood plywood, particleboard, and medium density fiberboard.”⁴ The measure applies to manufacturers, distributors, importers, fabricators (that use such materials to make other goods), retailers, third party certifiers who manufacture, offer for sale or supply these goods in California. The control measure assures that all building materials and furnishings manufactured, distributed, imported and used in new construction in California meet the maximum allowable concentrations that assure healthful indoor air quality.

According to CARB, from a public health standpoint, the Composite Wood Products (CWP) Regulation’s emission standards are set at low levels intended to protect public health.⁵ The CWP Regulation, adopted in 2007, established two phases of emissions standards: an initial Phase I, and later, a more stringent Phase 2 that requires all finished goods, such as flooring, destined for sale or use in California to be made using complying composite wood products. As of January 2014, only Phase 2 products are legal for sale in California. Thus, all new wood products installed in the Project would comply with the more stringent Phase 2 requirements.

Therefore, there is no evidence that the Project would create a significant air quality impact.

³ California Green Building Standard Code: <https://ww2.arb.ca.gov/our-work/programs/building-decarbonization/building-standards-code>, accessed August 2, 2022.

⁴ CARB, Composite Wood Products Airborne Toxic Control Measure: <https://ww2.arb.ca.gov/our-work/programs/composite-wood-products-program>, accessed August 2, 2022.

⁵ CARB, Frequently Asked Questions for Consumers, Reducing Formaldehyde Emissions from Composite Wood Products, https://ww3.arb.ca.gov/toxics/compwood/consumer_faq.pdf?_ga=2.32900281.682464648.1573169874-1026610208.1565143819, accessed August 2, 2022.

SAFER Comment 2

The Project will have a significant air quality impact. The fact that this significant impact will occur constitutes an unusual circumstance, precluding the City's reliance on an exemption.

Response to SAFER Comment 2

The SAFER Letter fails to meet its burden to show that the “unusual circumstances exception” to the Class 32 CE adopted for the Project applies. The arguments in the SAFER Letter are not supported by substantial evidence, as required by CEQA, and the SAFER Letter offers no substantial evidence to suggest potential significant air quality impacts at the Project Site. As discussed in **Response to SAFER Comment 1**, the SAFER Letter ignores the substantial evidence in record supporting the conclusion that the Project would not result in significant impacts, found in the CE and technical appendices.

The SAFER Letter incorrectly argues that the “unusual circumstances” exception to the CE under CEQA Guidelines Section 15300.2(c) applies here, citing the Berkeley Hillside Preservation v. City of Berkeley case.⁶ Notably, the SAFER Letter does not attempt to demonstrate the existence of an “unusual circumstance” here, nor could it, as the Project is a standard multi-family residential development on a flat, rectangular, unremarkable, highly urbanized infill site in the Hollywood Community Plan Area, and is thus exactly the kind of project to which the Class 32 CE was made to apply.⁷ In addition, the SAFER Letter analysis only supports the conclusion, even if assumed to be valid, that the alleged building and furnishing product impacts on indoor air quality would occur in every new multifamily project in the state, far from being an unusual circumstance.

The CE properly concludes no such unusual circumstances exist for the Project, a conclusion supported by substantial evidence in the record the SAFER Letter makes no effort to refute. (See CE, at pp. 2-125 to 2-126.),

The SAFER Letter relies on invalid, speculative and unsupported claims of significant impacts to support its conclusion of unusual circumstances. However, the alleged “evidence” relied on in the SAFER Letter is: (1) insufficient to show the substantial evidence relied on by the City in the CE is lacking; (2) is based on speculation and does not even constitute valid substantial evidence that the Project “may” result in a significant impact; and (3) fails to meet the much higher burden of establishing such an impact “will” occur with certainty, as is required to meet the secondary unusual circumstance test under the Berkeley Hillside case. The City appropriately determined the unusual circumstances exception does not apply here and nothing in the SAFER Letter demonstrates otherwise.

⁶ Berkeley Hillside Preservation v. City of Berkeley (2015) 60 Cal.4th 1086

⁷ See Berkeley Hillside, 60 Cal.4th, at at 1105, 1127

Exhibit G – Department Letters

BOARD OF PUBLIC WORKS
MEMBERS

AURA GARCIA
PRESIDENT

M. TERESA VILLEGAS
VICE PRESIDENT

DR. MICHAEL R. DAVIS
PRESIDENT PRO TEMPORE

VAHID KHORSAND
COMMISSIONER

SUSANA REYES
COMMISSIONER

DR. FERNANDO CAMPOS
EXECUTIVE OFFICER

CITY OF LOS ANGELES

CALIFORNIA



ERIC GARCETTI
MAYOR

DEPARTMENT OF
PUBLIC WORKS
BUREAU OF
ENGINEERING

TED ALLEN, PE
CITY ENGINEER

1149 S. BROADWAY, SUITE 700
LOS ANGELES, CA 90015-2213

<http://eng.lacity.org>

October 20, 2022

Three6ixty
Attn: Dana Sayles
11287 W. Washington Boulevard
Culver City, CA 90230

Dear Applicant:

Recently, you filed for **CPC 2022-7047 (CU/DB/SPR/HCA)** with the City Planning Department for the property located at 1200 N. Vine Street. Please be advised that **LAMC Section 61.16** requires the City Engineer to collect a fee before processing a report to the City Planning Department. The report will provide the specific requirements of the Bureau of Engineering for this project. The total amount owed for this application (including surcharges of 3% and 7%) is currently **\$8,072.90** payable to the City of Los Angeles. Delays in payment may result in changes to amount owed should the fees be increased. The fee may be paid online or by mail.

We will send you an electronic invoice payment link by a separate email. The processing of this application by the Bureau of Engineering will continue upon receipt of the fee.

To pay by mail:

Permit Case Management Division
201 N. Figueroa Street, Suite 290
Los Angeles, CA 90012
Attn: Public Counter

If you have any questions, please contact Quyen Phan through the Bureau of Engineering Customer Portal and request for service in the Customer Service Request box at <https://engpermits.lacity.org>. Thank you.

Sincerely,

Quyen Phan (for)

Bertram Moklebust, Principal Civil Engineer
Permit Case Management Division
Bureau of Engineering



CITY OF LOS ANGELES
INTER-DEPARTMENTAL CORRESPONDENCE

1200 N Vine St
DOT Case No. CEN22-53727

Date: December 19, 2022

To: Milena Zasadzien, Senior City Planner
Department of City Planning

From: Wes Pringle, Transportation Engineer
Department of Transportation

Subject: **TRANSPORTATION ASSESSMENT FOR THE PROPOSED MIXED-USE DEVELOPMENT
LOCATED AT 1200 NORTH VINE STREET (CPC-2022-7047-CU-DB-SPR-HCA/ ENV-2022-
7048-CE/PAR-2022-4084-AHRF)**

The Los Angeles Department of Transportation (LADOT) has reviewed the transportation assessment prepared by Gibson Transportation Consulting, Inc. (GTC), dated November 2, 2022, for the proposed mixed-use project at 1200, 1204, 1214, and 1218 North Vine Street and 6245 and 6247 West Lexington Avenue within the Central Area Planning Commission (APC) and a Transit Oriented Community (TOC) Tier 1. In compliance with Senate Bill (SB) 743 and the California Environmental Quality Act (CEQA), a vehicle miles traveled (VMT) analysis is required to identify the project's ability to promote the reduction of green-house gas emissions, the access to diverse land uses, and the development of multi-modal networks. The significance of a project's impact in this regard is measured against the VMT thresholds established in LADOT's Transportation Assessment Guidelines (TAG), as described below.

DISCUSSION AND FINDINGS

A. Project Description

The project proposes to construct an eight-story mixed-use development consisting of 153 (135 multi-family housing and 18 affordable housing) residential units and 7,000 square feet of commercial uses on the northeast corner of Vine Street and Lexington Avenue. A total of 93 vehicle parking spaces and 120 (106 long-term and 14 short-term) bicycle parking spaces will be provided onsite within one ground level and one above-grade level. Parking and the onsite loading zone will be accessed via one shared commercial and residential right-turn ingress and egress driveway on Vine Street and one residential only full access driveway on Lexington Avenue as illustrated in **Attachment A**. The project will also provide 174 (168 residential and six commercial) bicycle parking spaces onsite. The residential bicycle parking will have 153 long-term and 15 short-term spaces and the commercial bicycle parking will have three long-term and three short-term spaces. The project is expected to be completed by 2027.

B. Freeway Safety Analysis

Per the Interim Guidance for Freeway Safety Analysis memorandum issued by LADOT on May 1, 2020 to address Caltrans safety concerns on freeways, the study addresses the project's effects on vehicle queuing on freeway off-ramps. Such an evaluation measures the project's potential to lengthen a forecasted off-ramp queue and create speed differentials between vehicles exiting the freeway off-ramps and vehicles operating on the freeway mainline. The evaluation identified the number of project trips expected to be added to nearby freeway off-ramps serving the project site. It was determined that project traffic at any freeway off-ramp will not exceed 25 peak hour trips. Therefore, a freeway ramp analysis is not required.

C. CEQA Screening Threshold

Prior to accounting for trip reductions resulting from the application of Transportation Demand Management (TDM) Strategies, a trip generation analysis was conducted to determine if the project would exceed the net 250 daily vehicle trips screening threshold. Using the City of Los Angeles VMT Calculator tool, which draws upon trip rate estimates published in the Institute of Transportation Engineers (ITE) Trip Generation Manual, 9th Edition as well as applying trip generation adjustments when applicable, based on sociodemographic data and the built environment factors of the project's surroundings, it was determined that the project **does** exceed the net 250 daily vehicle trips threshold.

Additionally, the analysis included further discussion of the transportation impact thresholds:

- T-1 Conflicting with plans, programs, ordinances, or policies
- T-2.1 Causing substantial vehicle miles traveled
- T-3 Substantially increasing hazards due to a geometric design feature or incompatible use.

The assessment determined that the project would **not** have a significant transportation impact under Thresholds T-1 and T-3. A project's impacts per Threshold T-2.1 is determined by using the VMT calculator and is discussed further below. A copy of the VMT Calculator summary report is provided as **Attachment B** to this report.

D. Transportation Impacts

On July 30, 2019, pursuant to SB 743 and the recent changes to Section 15064.03 of the State's CEQA Guidelines, the City of Los Angeles adopted VMT as criteria in determining transportation impacts under CEQA. The LADOT TAG provide instructions on preparing transportation assessments for land use proposals and defines the significant impact thresholds.

The LADOT VMT Calculator tool measures project impact in terms of Household VMT per Capita, and Work VMT per Employee. LADOT identified distinct thresholds for significant VMT impacts for each of the seven APC areas in the City. For the Central APC area, in which the project is located, the following thresholds have been established:

- Household VMT per Capita: 6.0
- Work VMT per Employee: 7.6

As cited in the VMT Analysis report prepared by GTC, the project proposes to incorporate the TDM strategies of reducing the parking supply from 311 to 93 spaces and including bike parking per Los Angeles Municipal Code (LAMC) as project design features. With the application of this TDM strategy, the proposed project is projected to have a Household VMT per capita of 3.7 and no Work VMT. Therefore, it is concluded that implementation of the project would result in no significant VMT impact. A copy of the VMT Calculator summary report is provided as **Attachment B**.

E. Access and Circulation

During preparation of the new CEQA guidelines, the State's Office of Planning and Research stressed that lead agencies can continue to apply traditional operational analysis requirements to inform land use decisions provided that such analyses were outside of the CEQA process. The authority for requiring non-CEQA transportation analysis and requiring improvements to address potential circulation deficiencies, lies in the City of Los Angeles' Site Plan Review authority as established in Section 16.05 of the LAMC. Therefore, LADOT continues to require

and review a project's site access, circulation, and operational plan to determine if any access enhancements, transit amenities, intersection improvements, traffic signal upgrades, neighborhood traffic calming, or other improvements are needed. In accordance with this authority, the project has completed a circulation analysis using a "level of service" screening methodology that indicates that the trips generated by the proposed development will not likely result in adverse circulation conditions at several locations. Vehicular access to the project will be provided along Vine Street and Lexington Avenue. LADOT has reviewed this analysis and determined that it adequately discloses operational concerns. A copy of the circulation analysis table that summarizes these potential deficiencies is provided as **Attachment C** to this report.

PROJECT REQUIREMENTS

Non-CEQA-Related Requirements and Considerations

To comply with transportation and mobility goals and provisions of adopted City plans and ordinances, the applicant should be required to implement the following:

1. Parking Requirements

The project would provide parking for 93 vehicles and 174 bicycles. The applicant should check with the Departments of Building and Safety and City Planning on the number of parking spaces required for this project within a TOC Tier 3.

2. Highway Dedication and Street Widening Requirements

Per the new Mobility Element of the General Plan, **Vine Street**, an Avenue II, would require a 40-foot half-width roadway within a 55-foot half-width right-of-way and **Lexington Avenue**, a Local Street, would require an 18-foot roadway within a 30-foot half-width right-of-way. The applicant should coordinate with the Bureau of Engineering's Land Development Group who will determine if there are any other applicable highway dedication, street widening and/or sidewalk requirements for this project.

3. Project Access and Circulation

The conceptual site plan for the project (see **Attachment A**) is acceptable to LADOT. The project would be accessed along Vine Street and Lexington Avenue. Review of this study does not constitute approval of the dimensions for any new proposed driveways. Review and approval of new driveways should be coordinated with LADOT's Citywide Planning Coordination Section (201 North Figueroa Street, 5th Floor, Room 550, at 213-482-7024). In order to minimize and prevent last minute building design changes, the applicant should contact LADOT for driveway width and internal circulation requirements prior to the commencement of building or parking layout design. The applicant should check with City Planning regarding the project's vehicular access and design.

4. Worksite Traffic Control Requirements

LADOT recommends that a construction work site traffic control plan be submitted to LADOT's Citywide Temporary Traffic Control Section or Permit Plan Review Section for review and approval prior to the start of any construction work. Refer to <http://ladot.lacity.org/businesses/temporary-traffic-control-plans> to determine which section to coordinate review of the work site traffic control plan. The plan should show the location of any roadway or sidewalk closures, traffic detours, haul routes, hours of operation, protective devices, warning signs and access to abutting properties. LADOT also recommends that all construction related truck traffic be restricted to off-peak hours to the extent feasible.

5. TDM Ordinance Requirements

The TDM Ordinance (LAMC 12.26 J) is currently being updated. The updated ordinance, which is currently progressing through the City's approval process, will:

- Expand the reach and application of TDM strategies to more land uses and neighborhoods,
- Rely on a broader range of strategies that can be updated to keep pace with technology, and
- Provide flexibility for developments and communities to choose strategies that work best for their neighborhood context.

Although not yet adopted, LADOT recommends that the applicant be subject to the terms of the proposed TDM Ordinance update. The updated ordinance is expected to be completed prior to the anticipated construction of this project, if approved.

6. Development Review Fees

Section 19.15 of the LAMC identifies specific fees for traffic study review, condition clearance, and permit issuance. The applicant shall comply with any applicable fees per this ordinance.

If you have any questions, please contact Eileen Hunt of my staff at (213) 972-8481.

Attachments

K:\Letters\2022\CEN22-53727_1200 Vine St_MU_ltr.docx

- c: Council District 13
Hokchi Chiu, Central District, BOE
Bhuvan Bajaj, Hollywood-Wilshire District, DOT
Taimour Tanavoli, Case Management Office, DOT
Lauren Mullarkey-Williams/Emily Wong, GTC

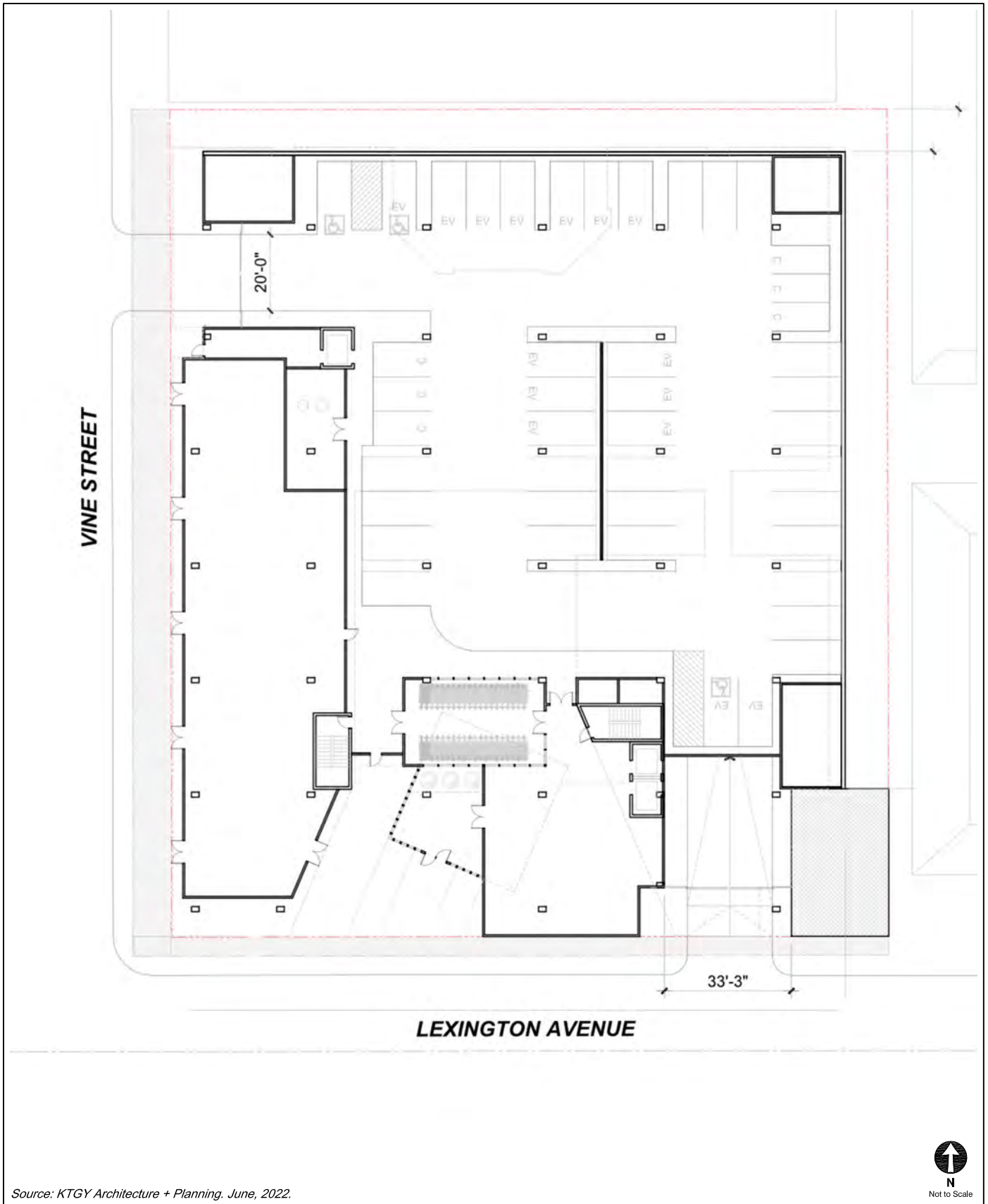

Source: KTG Architecture + Planning, June, 2022.

PROJECT SITE PLAN

FIGURE
1

CITY OF LOS ANGELES VMT CALCULATOR Version 1.3



Project Screening Criteria: Is this project required to conduct a vehicle miles traveled analysis?

Project Information

Project:

Scenario:

Address:

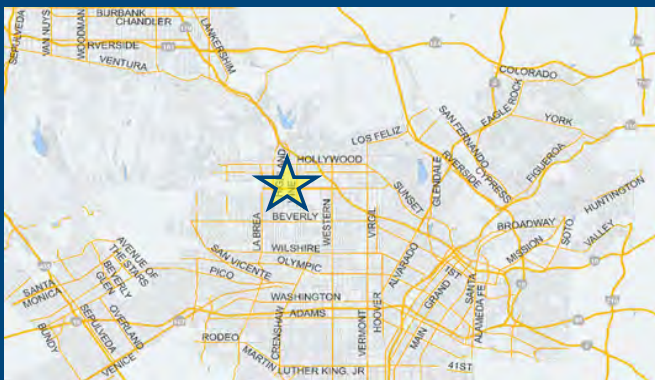

Is the project replacing an existing number of residential units with a smaller number of residential units AND is located within one-half mile of a fixed-rail or fixed-guideway transit

Yes No

Existing Land Use

Land Use Type	Value	Unit
Housing Single Family		DU

[Click here to add a single custom land use type \(will be included in the above list\)](#)

Proposed Project Land Use

Land Use Type	Value	Unit
Retail High-Turnover Sit-Down Restaurant	7	ksf
Housing Multi-Family	135	DU
Housing Affordable Housing - Family	18	DU
Retail High-Turnover Sit-Down Restaurant	7	ksf

[Click here to add a single custom land use type \(will be included in the above list\)](#)

Project Screening Summary

Existing Land Use	Proposed
0 Daily Vehicle Trips	1,025 Daily Vehicle Trips
0 Daily VMT	6,092 Daily VMT
Tier 1 Screening Criteria	
Project will have less residential units compared to existing residential units & is within one-half mile of a fixed-rail station. <input type="checkbox"/>	
Tier 2 Screening Criteria	
The net increase in daily trips < 250 trips	1,025 Net Daily Trips
The net increase in daily VMT ≤ 0	6,092 Net Daily VMT
The proposed project consists of only retail land uses ≤ 50,000 square feet total.	7.000 ksf
The proposed project is required to perform VMT analysis.	



CITY OF LOS ANGELES VMT CALCULATOR Version 1.3



Project Information

Project:

Scenario:

Address:

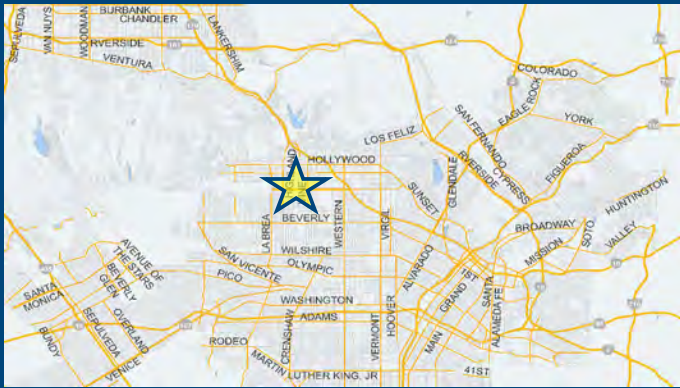

Proposed Project Land Use Type	Value	Unit
Housing Multi-Family	135	DU
Housing Affordable Housing - Family	18	DU
Retail High-Turnover Sit-Down Restaurant	7	ksf

TDM Strategies

Select each section to show individual strategies
Use to denote if the TDM strategy is part of the proposed project or is a mitigation strategy

	Proposed Project	With Mitigation
Max Home Based TDM Achieved?	No	No
Max Work Based TDM Achieved?	No	No

A Parking

B Transit

C Education & Encouragement

D Commute Trip Reductions

E Shared Mobility

F Bicycle Infrastructure

Implement/Improve On-street Bicycle Facility Select Proposed Prj or Mitigation to include this strategy
 Proposed Prj Mitigation

Include Bike Parking Per LAMC Select Proposed Prj or Mitigation to include this strategy
 Proposed Prj Mitigation

Include Secure Bike Parking and Showers Select Proposed Prj or Mitigation to include this strategy
 Proposed Prj Mitigation

G Neighborhood Enhancement

Analysis Results

Proposed Project	With
892 Daily Vehicle Trips	892 Daily Vehicle Trips
5,297 Daily VMT	5,297 Daily VMT
3.7 Household VMT per Capita	3.7 Household VMT
N/A Work VMT per Employee	N/A Work VMT per Employee
Significant VMT Impact?	
Household: No Threshold = 6.0 15% Below APC	Household: No Threshold = 6.0 15% Below APC
Work: N/A Threshold = 7.6 15% Below APC	Work: N/A Threshold = 7.6 15% Below APC



CITY OF LOS ANGELES VMT CALCULATOR

Report 1: Project & Analysis Overview

Date: September 13, 2022

Project Name: 1200 Vine Street

Project Scenario:

Project Address: 1200 N VINE ST, 90038



Version 1.3

Project Information			
Land Use Type		Value	Units
Housing	Single Family	0	DU
	Multi Family	135	DU
	Townhouse	0	DU
	Hotel	0	Rooms
	Motel	0	Rooms
Affordable Housing	Family	18	DU
	Senior	0	DU
	Special Needs	0	DU
	Permanent Supportive	0	DU
Retail	General Retail	0.000	ksf
	Furniture Store	0.000	ksf
	Pharmacy/Drugstore	0.000	ksf
	Supermarket	0.000	ksf
	Bank	0.000	ksf
	Health Club	0.000	ksf
	High-Turnover Sit-Down Restaurant	7.000	ksf
	Fast-Food Restaurant	0.000	ksf
	Quality Restaurant	0.000	ksf
	Auto Repair	0.000	ksf
	Home Improvement	0.000	ksf
	Free-Standing Discount	0.000	ksf
	Movie Theater	0	Seats
	Office	General Office	0.000
Medical Office		0.000	ksf
Industrial	Light Industrial	0.000	ksf
	Manufacturing	0.000	ksf
	Warehousing/Self-Storage	0.000	ksf
School	University	0	Students
	High School	0	Students
	Middle School	0	Students
	Elementary	0	Students
	Private School (K-12)	0	Students
Other		0	Trips

Analysis Results			
Total Employees: 28			
Total Population: 361			
Proposed Project		With Mitigation	
892	Daily Vehicle Trips	892	Daily Vehicle Trips
5,297	Daily VMT	5,297	Daily VMT
3.7	Household VMT per Capita	3.7	Household VMT per Capita
N/A	Work VMT per Employee	N/A	Work VMT per Employee
Significant VMT Impact?			
APC: Central			
Impact Threshold: 15% Below APC Average			
Household = 6.0			
Work = 7.6			
Proposed Project		With Mitigation	
VMT Threshold	Impact	VMT Threshold	Impact
Household > 6.0	No	Household > 6.0	No
Work > 7.6	N/A	Work > 7.6	N/A



TDM Strategy Inputs				
Strategy Type	Description	Proposed Project	Mitigations	
Parking	Reduce parking supply	City code parking provision (spaces)	311	311
		Actual parking provision (spaces)	93	93
	Unbundle parking	Monthly cost for parking (\$)	\$0	\$0
	Parking cash-out	Employees eligible (%)	0%	0%
		Daily parking charge (\$)	\$0.00	\$0.00
	Price workplace parking	Employees subject to priced parking (%)	0%	0%
	Residential area parking permits	Cost of annual permit (\$)	\$0	\$0
(cont. on following page)				

TDM Strategy Inputs, Cont.				
Strategy Type	Description	Proposed Project	Mitigations	
Transit	Reduce transit headways	Reduction in headways (increase in frequency) (%)	0%	0%
		Existing transit mode share (as a percent of total daily trips) (%)	0%	0%
		Lines within project site improved (<50%, >=50%)	0	0
	Implement neighborhood shuttle	Degree of implementation (low, medium, high)	0	0
		Employees and residents eligible (%)	0%	0%
	Transit subsidies	Amount of transit subsidy per passenger (daily equivalent) (\$)	\$0.00	\$0.00
Education & Encouragement	Voluntary travel behavior change program	Employees and residents participating (%)	0%	0%
	Promotions and marketing	Employees and residents participating (%)	0%	0%
(cont. on following page)				

TDM Strategy Inputs, Cont.				
Strategy Type	Description	Proposed Project	Mitigations	
Commuter Trip Reductions	Required commute trip reduction program	Employees participating (%)	0%	0%
		Type of program	0	0
	Employer sponsored vanpool or shuttle	Degree of implementation (low, medium, high)	0	0
		Employees eligible (%)	0%	0%
		Employer size (small, medium, large)	0	0
	Ride-share program	Employees eligible (%)	0%	0%
Shared Mobility	Car share	Car share project setting (Urban, Suburban, All Other)	0	0
	Bike share	Within 600 feet of existing bike share station - OR - implementing new bike share station (Yes/No)	0	0
	School carpool program	Level of implementation (Low, Medium, High)	0	0
(cont. on following page)				

TDM Strategy Inputs, Cont.				
Strategy Type	Description	Proposed Project	Mitigations	
Bicycle Infrastructure	Implements/improve on-street bicycle facility	Provide bicycle facility along site (Yes/No)	0	0
	Include Bike parking per LAMC	Meets City Bike Parking Code (Yes/No)	Yes	Yes
	Include secure bike parking and showers	Includes indoor bike parking/lockers, showers, & repair station (Yes/No)	0	0
Neighborhood Enhancement	Traffic calming improvements	Streets with traffic calming improvements (%)	0%	0%
		Intersections with traffic calming improvements (%)	0%	0%
	Pedestrian network improvements	Included (within project and connecting off-site/within project only)	0	0



Report 3: TDM Outputs

TDM Adjustments by Trip Purpose & Strategy														
Place type: Urban														
		Home Based Work Production		Home Based Work Attraction		Home Based Other Production		Home Based Other Attraction		Non-Home Based Other Production		Non-Home Based Other Attraction		Source
		Proposed	Mitigated	Proposed	Mitigated	Proposed	Mitigated	Proposed	Mitigated	Proposed	Mitigated	Proposed	Mitigated	
Parking	Reduce parking supply	13%	13%	13%	13%	13%	13%	13%	13%	13%	13%	13%	13%	TDM Strategy Appendix, Parking sections 1 - 5
	Unbundle parking	0%	0%	0%	0%	0%	0%	0%	0%	0%	0%	0%	0%	
	Parking cash-out	0%	0%	0%	0%	0%	0%	0%	0%	0%	0%	0%	0%	
	Price workplace parking	0%	0%	0%	0%	0%	0%	0%	0%	0%	0%	0%	0%	
Transit	Residential area parking permits	0.00%	0.00%	0.00%	0.00%	0.00%	0.00%	0.00%	0.00%	0.00%	0.00%	0.00%	0.00%	TDM Strategy Appendix, Transit sections 1 - 3
	Reduce transit headways	0%	0%	0%	0%	0%	0%	0%	0%	0%	0%	0%	0%	
	Implement neighborhood shuttle	0%	0%	0%	0%	0%	0%	0%	0%	0%	0%	0%	0%	
Education & Encouragement	Transit subsidies	0%	0%	0%	0%	0%	0%	0%	0%	0%	0%	0%	0%	TDM Strategy Appendix, Education & Encouragement sections 1 - 2
	Voluntary travel behavior change program	0%	0%	0%	0%	0%	0%	0%	0%	0%	0%	0%	0%	
Commuter Trip Reductions	Promotions and marketing	0%	0%	0%	0%	0%	0%	0%	0%	0%	0%	0%	0%	TDM Strategy Appendix, Commute Trip Reductions sections 1 - 4
	Required commute trip reduction program	0%	0%	0%	0%	0%	0%	0%	0%	0%	0%	0%	0%	
	Alternative Work Schedules and Telecommute Program	0%	0%	0%	0%	0%	0%	0%	0%	0%	0%	0%	0%	
	Employer sponsored vanpool or shuttle	0%	0%	0%	0%	0%	0%	0%	0%	0%	0%	0%	0%	
Shared Mobility	Ride-share program	0%	0%	0%	0%	0%	0%	0%	0%	0%	0%	0%	0%	TDM Strategy Appendix, Shared Mobility sections 1 - 3
	Car-share	0.00%	0.00%	0.00%	0.00%	0.00%	0.00%	0.00%	0.00%	0.00%	0.00%	0.00%	0.00%	
	Bike share	0.00%	0.00%	0.00%	0.00%	0.00%	0.00%	0.00%	0.00%	0.00%	0.00%	0.00%	0.00%	

TDM Adjustments by Trip Purpose & Strategy, Cont.														
Place type: Urban														
		Home Based Work Production		Home Based Work Attraction		Home Based Other Production		Home Based Other Attraction		Non-Home Based Other Production		Non-Home Based Other Attraction		Source
		Proposed	Mitigated	Proposed	Mitigated	Proposed	Mitigated	Proposed	Mitigated	Proposed	Mitigated	Proposed	Mitigated	
Bicycle Infrastructure	Implement/ Improve on-street bicycle facility	0.0%	0.0%	0.0%	0.0%	0.0%	0.0%	0.0%	0.0%	0.0%	0.0%	0.0%	0.0%	TDM Strategy Appendix, Bicycle Infrastructure sections 1 - 3
	Include Bike parking per LAMC	0.6%	0.6%	0.6%	0.6%	0.6%	0.6%	0.6%	0.6%	0.6%	0.6%	0.6%	0.6%	
	Include secure bike parking and showers	0.0%	0.0%	0.0%	0.0%	0.0%	0.0%	0.0%	0.0%	0.0%	0.0%	0.0%	0.0%	
Neighborhood Enhancement	Traffic calming improvements	0.0%	0.0%	0.0%	0.0%	0.0%	0.0%	0.0%	0.0%	0.0%	0.0%	0.0%	0.0%	TDM Strategy Appendix, Neighborhood Enhancement
	Pedestrian network improvements	0.0%	0.0%	0.0%	0.0%	0.0%	0.0%	0.0%	0.0%	0.0%	0.0%	0.0%	0.0%	

Final Combined & Maximum TDM Effect														
		Home Based Work Production		Home Based Work Attraction		Home Based Other Production		Home Based Other Attraction		Non-Home Based Other Production		Non-Home Based Other Attraction		
		Proposed	Mitigated	Proposed	Mitigated	Proposed	Mitigated	Proposed	Mitigated	Proposed	Mitigated	Proposed	Mitigated	
COMBINED TOTAL		13%	13%	13%	13%	13%	13%	13%	13%	13%	13%	13%	13%	
MAX. TDM EFFECT		13%	13%	13%	13%	13%	13%	13%	13%	13%	13%	13%	13%	

$$= \text{Minimum}(X\%, 1 - [(1-A) * (1-B)...])$$

where X%=

PLACE	urban	75%
TYPE MAX:	compact infill	40%
	suburban center	20%
	suburban	15%

Note: $(1 - [(1-A) * (1-B)...])$ reflects the dampened combined effectiveness of TDM Strategies (e.g., A, B,...). See the TDM Strategy Appendix (*Transportation Assessment Guidelines Attachment G*) for further discussion of dampening.

CITY OF LOS ANGELES VMT CALCULATOR

Report 4: MXD Methodology

Date: September 13, 2022

Project Name: 1200 Vine Street

Project Scenario:

Project Address: 1200 N VINE ST, 90038



Version 1.3

MXD Methodology - Project Without TDM

	Unadjusted Trips	MXD Adjustment	MXD Trips	Average Trip Length	Unadjusted VMT	MXD VMT
Home Based Work Production	136	-31.6%	93	7.1	966	660
Home Based Other Production	377	-48.3%	195	4.4	1,659	858
Non-Home Based Other Production	306	-6.9%	285	6.9	2,111	1,967
Home-Based Work Attraction	41	-48.8%	21	8.5	349	179
Home-Based Other Attraction	477	-43.0%	272	5.3	2,528	1,442
Non-Home Based Other Attraction	172	-7.6%	159	6.2	1,066	986

MXD Methodology with TDM Measures

	<i>Proposed Project</i>			<i>Project with Mitigation Measures</i>		
	TDM Adjustment	Project Trips	Project VMT	TDM Adjustment	Mitigated Trips	Mitigated VMT
Home Based Work Production	-13.0%	81	574	-13.0%	81	574
Home Based Other Production	-13.0%	170	746	-13.0%	170	746
Non-Home Based Other Production	-13.0%	248	1,710	-13.0%	248	1,710
Home-Based Work Attraction	-13.0%	18	156	-13.0%	18	156
Home-Based Other Attraction	-13.0%	237	1,254	-13.0%	237	1,254
Non-Home Based Other Attraction	-13.0%	138	857	-13.0%	138	857

MXD VMT Methodology Per Capita & Per Employee

Total Population: 361

Total Employees: 28

APC: Central

	<i>Proposed Project</i>	<i>Project with Mitigation Measures</i>
<i>Total Home Based Production VMT</i>	1,320	1,320
<i>Total Home Based Work Attraction VMT</i>	156	156
<i>Total Home Based VMT Per Capita</i>	3.7	3.7
<i>Total Work Based VMT Per Employee</i>	N/A	N/A

**TABLE 8
FUTURE CONDITIONS (YEAR 2027)
INTERSECTION LEVELS OF SERVICE**

No	Intersection [a]	Peak Hour	Future without Project Conditions		Future with Project Conditions	
			Delay	LOS	Delay	LOS
1.	Vine Street & Fountain Avenue	AM	32.2	C	32.7	C
		PM	36.3	D	38.0	D
2.	Vine Street & Lexington Avenue	AM	6.1	A	7.5	A
		PM	9.0	A	9.9	A

Notes:

Delay is measured in seconds per vehicle. LOS = Level of Service.

[a] Intersection analysis based on HCM 6th Edition Signalized methodology, which calculates the average intersection delay, in seconds, for each vehicle passing through the intersection.

CITY OF LOS ANGELES
INTER-DEPARTMENTAL CORRESPONDENCE

October 21, 2022

TO: Vincent Bertoni, AICP, Director of Planning
Department of City Planning
Attention: Planning.expedited@lacity.org

FROM: Los Angeles Fire Department

SUBJECT: **CPC-2022-7047.: 1200 N Vine St**

Submit plot plans for Fire Department approval and review prior to recordation of City Planning Case.

RECOMMENDATIONS:

Access for Fire Department apparatus and personnel to and into all structures shall be required.

Address identification. New and existing buildings shall have approved building identification placed in a position that is plainly legible and visible from the street or road fronting the property.

One or more Knox Boxes will be required to be installed for LAFD access to project. Location and number to be determined by LAFD Field Inspector. (Refer to FPB Req # 75).

The entrance or exit of all ground dwelling units shall not be more than 150 feet from the edge of a roadway of an improved street, access road, or designated fire lane.

No building or portion of a building shall be constructed more than 150 feet from the edge of a roadway of an improved street, access road, or designated fire lane.

Fire Lane Requirements:

- 1) Fire lane width shall not be less than 20 feet. When a fire lane must accommodate the operation of Fire Department aerial ladder apparatus or where fire hydrants are installed, those portions shall not be less than 28 feet in width.
- 2) The width of private roadways for general access use and fire lanes shall not be less than 20 feet, and the fire lane must be clear to the sky.
- 3) Fire lanes, where required and dead ending streets shall terminate in a cul-de-sac or other approved turning area. No dead ending street or fire lane shall be greater than 700 feet in length or secondary access shall be required.
- 4) Submit plot plans indicating access road and turning area for Fire Department approval.
- 5) All parking restrictions for fire lanes shall be posted and/or painted prior to any Temporary Certificate of Occupancy being issued.
- 6) Plans showing areas to be posted and/or painted, "FIRE LANE NO PARKING" shall be submitted and approved by the Fire Department prior to building permit application sign-off.
- 7) Electric Gates approved by the Fire Department shall be tested by the Fire Department prior to Building and Safety granting a Certificate of Occupancy.
- 8) All public street and fire lane cul-de-sacs shall have the curbs painted red and/or be posted "No Parking at Any Time" prior to the issuance of a Certificate of Occupancy or Temporary Certificate of Occupancy for any structures adjacent to the cul-de-sac.
- 9) No framing shall be allowed until the roadway is installed to the satisfaction of the Fire Department.

Construction of public or private roadway in the proposed development shall not exceed 10 percent in grade.

On small lot subdivisions, any lots used for access purposes shall be recorded on the final map as a "Fire Lane".

Private development shall conform to the standard street dimensions shown on Department of Public Works Standard Plan S-470-0.

Standard cut-corners will be used on all turns.

The Fire Department may require additional vehicular access where buildings exceed 28 feet in height.

Smoke Vents may be required where roof access is not possible; location and number of vents to be determined at Plan Review.

Where above ground floors are used for residential purposes, the access requirement shall be interpreted as being the horizontal travel distance from the street, driveway, alley, or designated fire lane to the main entrance of individual units.

The following recommendations of the Fire Department relative to fire safety shall be incorporated into the building plans, which includes the submittal of a plot plan for approval by the Fire Department either prior to the recordation of a final map or the approval of a building permit. The plot plan shall include the following minimum design features: fire lanes, where required, shall be a minimum of 20 feet in width; all structures must be within 300 feet of an approved fire hydrant, and entrances to any dwelling unit or guest room shall not be more than 150 feet in distance in horizontal travel from the edge of the roadway of an improved street or approved fire lane.

2014 CITY OF LOS ANGELES FIRE CODE, SECTION 503.1.4 (EXCEPTION)

- a. When this exception is applied to a fully fire sprinklered residential building equipped with a wet standpipe outlet inside an exit stairway with at least a 2 hour rating the distance from the wet standpipe outlet in the stairway to the entry door of any dwelling unit or guest room shall not exceed 150 feet of horizontal travel AND the distance from the edge of the roadway of an improved street or approved fire lane to the door into the same exit stairway directly from outside the building shall not exceed 150 feet of horizontal travel.
- b. It is the intent of this policy that in no case will the maximum travel distance exceed 150 feet inside the structure and 150 feet outside the structure. The term "horizontal travel" refers to the actual path of travel to be taken by a person responding to an emergency in the building.
- c. This policy does not apply to single-family dwellings or to non-residential buildings.

Site plans shall include all overhead utility lines adjacent to the site.

Where access for a given development requires accommodation of Fire Department apparatus, overhead clearance shall not be less than 14 feet.

No proposed development utilizing cluster, group, or condominium design of one or two family dwellings shall be more than 150 feet from the edge of the roadway of an improved street, access road, or designated fire lane.

FPB #105

5101.1 Emergency responder radio coverage in new buildings. All new buildings shall have approved radio coverage for emergency responders within the building based upon the existing coverage levels of the public safety communication systems of the jurisdiction at the exterior of the building. This section shall not require improvement of the existing public safety communication systems.

That in order to provide assurance that the proposed common fire lane and fire protection facilities, for the project, not maintained by the City, are properly and adequately maintained, the sub-divider shall record with the County Recorder, prior to the recordation of the final map, a covenant and agreement (Planning Department General Form CP-6770) to assure the following:

- A. The establishment of a property owners association, which shall cause a yearly inspection to be, made by a registered civil engineer of all common fire lanes and fire protection facilities. The association will undertake any necessary maintenance and corrective measures. Each future property owner shall automatically become a member of the association or organization required above and is automatically subject to a proportionate share of the cost.
- B. The future owners of affected lots with common fire lanes and fire protection facilities shall be informed of their responsibility for the maintenance of the devices on their lots. The future owner and all successors will be presented with a copy of the maintenance program for their lot. Any amendment or modification that would defeat the obligation of said association as the Advisory Agency must approve required hereinabove in writing after consultation with the Fire Department.
- C. In the event that the property owners association fails to maintain the common property and easements as required by the CC and R's, the individual property owners shall be responsible for their proportional share of the maintenance.
- D. Prior to any building permits being issued, the applicant shall improve, to the satisfaction of the Fire Department, all common fire lanes and install all private fire hydrants to be required.
- E. That the Common Fire Lanes and Fire Protection facilities be shown on the Final Map.

The plot plans shall be approved by the Fire Department showing fire hydrants and access for each phase of the project prior to the recording of the final map for that phase. Each phase shall comply independently with code requirements.

Any roof elevation changes in excess of 3 feet may require the installation of ships ladders.

Provide Fire Department pathway front to rear with access to each roof deck via gate or pony wall

less than 36 inches.

Building designs for multi-storied residential buildings shall incorporate at least one access stairwell off the main lobby of the building; But, in no case greater than 150ft horizontal travel distance from the edge of the public street, Private Street or Fire Lane. This stairwell shall extend onto the roof.

Entrance to the main lobby shall be located off the address side of the building.

Any required Fire Annunciator panel or Fire Control Room shall be located within 20ft visual line of site of the main entrance stairwell or to the satisfaction of the Fire Department.

Where rescue window access is required, provide conditions and improvements necessary to meet accessibility standards as determined by the Los Angeles Fire Department.

Adequate off-site public and on-site private fire hydrants may be required. Their number and location to be determined after the Fire Department's review of the plot plan.

Any required fire hydrants to be installed shall be fully operational and accepted by the Fire Department prior to any building construction.

The applicant is further advised that all subsequent contact regarding these conditions must be with the Hydrant and Access Unit. This would include clarification, verification of condition compliance and plans or building permit applications, etc., and shall be accomplished **BY APPOINTMENT ONLY**, in order to assure that you receive service with a minimum amount of waiting please call **(213) 482-6543**. You should advise any consultant representing you of this requirement as well.

Kristin M. Crowley
Fire Chief

Orin Saunders, Fire Marshal
Bureau of Fire Prevention and Public Safety

OS:MRC:mrc

CPC-2022-7047.: 1200 N Vine St

CITY OF LOS ANGELES
INTER-DEPARTMENTAL CORRESPONDENCE

DATE: December 22, 2022

TO: Heather Bleemers, Senior City Planner
Department of City Planning

FROM:  Bryan Ramirez, Street Tree Superintendent I
Bureau of Street Services, Urban Forestry Division

SUBJECT: CPC-2022-7047 - 1200 N. VINE ST.

In regard to your request for review of this case regarding Urban Forestry requirements, it is our recommendation that:

1. STREET TREES

- a. Project shall preserve all healthy mature street trees whenever possible. All feasible alternatives in project design should be considered and implemented to retain healthy mature street trees. A permit is required for the removal of any street tree and shall be replaced 2:1 as approved by the Board of Public Works and Urban Forestry Division.
- b. Plant street trees at all feasible planting locations within dedicated streets as directed and required by the Bureau of Street Services, Urban Forestry Division. All tree plantings shall be installed to current tree planting standards when the City has previously been paid for tree plantings. The subdivider or contractor shall notify the Urban Forestry Division at: (213) 847-3077 upon completion of construction for tree planting direction and instructions.

Note: Removal of street trees requires approval from the Board of Public Works. All projects must have environmental (CEQA) documents that appropriately address any removal and replacement of street trees. Contact Urban Forestry Division at: (213) 847-3077 for tree removal permit information.

BR:djm

INITIAL SUBMISSIONS

The following submissions by the public are in compliance with the Commission Rules and Operating Procedures (ROPs), Rule 4.3a. Please note that “compliance” means that the submission complies with deadline, delivery method (hard copy and/or electronic) AND the number of copies. The Commission’s ROPs can be accessed at <http://planning.lacity.org>, by selecting “Commissions & Hearings” and selecting the specific Commission.

The following submissions are not integrated or addressed in the Staff Report but have been distributed to the Commission.

Material which does not comply with the submission rules is not distributed to the Commission.

ENABLE BOOKMARKS ONLINE:

**If you are using Explorer, you will need to enable the Acrobat  toolbar to see the bookmarks on the left side of the screen.

If you are using Chrome, the bookmarks are on the upper right-side of the screen. If you do not want to use the bookmarks, simply scroll through the file.

If you have any questions, please contact the Commission Office at (213) 978-1300.

P: (626) 381-9248
F: (626) 389-5414
E: info@mitschsailaw.com



Mitchell M. Tsai
Attorney At Law

139 South Hudson Avenue
Suite 200
Pasadena, California 91101

VIA E-MAIL

April 27, 2023

Stephanie Escobar
City of Los Angeles
200 N. Spring Street, Suite 525
Los Angeles, CA 90012
Em: stephanie.escobar@lacity.org

RE: 1200-1218 N. Vine St. Project [ENV-2022-7048-CE]

Dear Honorable Commissioners,

On behalf of the Southwest Mountain States Regional Council of Carpenters (“**The Carpenters**” or “**SWMSRCC**”), my Office is submitting these comments to the City of Los Angeles (“**City**”) regarding the 1200-1218 N. Vine Street project (“**Project**”).

SWMSRCC is a labor union representing 50,000 union carpenters in six states, including California, and has a strong interest in well ordered land use planning and addressing the environmental impacts of development projects. Individual members of the Southwest Carpenters live, work and recreate in the City and surrounding communities and would be directly affected by the Project’s environmental impacts.

SWMSRCC expressly reserves the right to supplement these comments at or prior to hearings on the Project, and at any later hearings and proceedings related to this Project. Cal. Gov. Code § 65009(b); Cal. Pub. Res. Code § 21177(a); *Bakersfield Citizens for Local Control v. Bakersfield* (2004) 124 Cal. App. 4th 1184, 1199-1203; see *Galante Vineyards v. Monterey Water Dist.* (1997) 60 Cal. App. 4th 1109, 1121.

SWMSRCC incorporates by reference all comments raising issues regarding the Project’s environmental review submitted prior to approval of the Project. *Citizens for Clean Energy v. City of Woodland* (2014) 225 Cal. App. 4th 173, 191 (finding that any party who has objected to the Project’s environmental documentation may assert any issue timely raised by other parties).

SWMSRCC also requests that the City provide notice for any and all notices referring or related to the Project issued under the California Environmental Quality Act

(“**CEQA**”), Cal Public Resources Code (“**PRC**”) § 21000 *et seq.*, and the California Planning and Zoning Law (“**Planning and Zoning Law**”), Cal. Gov’t Code §§ 65000–65010. California Public Resources Code Sections 21092.2, and 21167(f) and Government Code Section 65092 require agencies to mail such notices to any person who has filed a written request for them with the clerk of the agency’s governing body.

I. THE CITY SHOULD REQUIRE THE USE OF A LOCAL WORKFORCE TO BENEFIT THE COMMUNITY’S ECONOMIC DEVELOPMENT AND ENVIRONMENT

As noted in our previous letters, the City should require the Project to be built using a local workers who have graduated from a Joint Labor-Management Apprenticeship Program approved by the State of California, have at least as many hours of on-the-job experience in the applicable craft which would be required to graduate from such a state-approved apprenticeship training program, or who are registered apprentices in a state-approved apprenticeship training program.

Community benefits such as local hire can also be helpful to reduce environmental impacts and improve the positive economic impact of the Project. Local hire provisions requiring that a certain percentage of workers reside within 10 miles or less of the Project site can reduce the length of vendor trips, reduce greenhouse gas emissions, and provide localized economic benefits. As environmental consultants Matt Hagemann and Paul E. Rosenfeld note:

[A]ny local hire requirement that results in a decreased worker trip length from the default value has the potential to result in a reduction of construction-related GHG emissions, though the significance of the reduction would vary based on the location and urbanization level of the project site.

March 8, 2021 SWAPE Letter to Mitchell M. Tsai re Local Hire Requirements and Considerations for Greenhouse Gas Modeling.

Workforce requirements promote the development of skilled trades that yield sustainable economic development. As the California Workforce Development Board and the University of California, Berkeley Center for Labor Research and Education concluded:

[L]abor should be considered an investment rather than a cost—and investments in growing, diversifying, and upskilling California’s workforce

can positively affect returns on climate mitigation efforts. In other words, well-trained workers are key to delivering emissions reductions and moving California closer to its climate targets.¹

Furthermore, workforce policies have significant environmental benefits given that they improve an area’s jobs-housing balance, decreasing the amount and length of job commutes and the associated greenhouse gas (“**GHG**”) emissions. In fact, on May 7, 2021, the South Coast Air Quality Management District found that that the “[u]se of a local state-certified apprenticeship program” can result in air pollutant reductions.²

Locating jobs closer to residential areas can have significant environmental benefits. As the California Planning Roundtable noted in 2008:

People who live and work in the same jurisdiction would be more likely to take transit, walk, or bicycle to work than residents of less balanced communities and their vehicle trips would be shorter. Benefits would include potential reductions in both vehicle miles traveled and vehicle hours traveled.³

Moreover, local hire mandates and skill-training are critical facets of a strategy to reduce vehicle miles traveled (“**VMT**”). As planning experts Robert Cervero and Michael Duncan have noted, simply placing jobs near housing stock is insufficient to achieve VMT reductions given that the skill requirements of available local jobs must match those held by local residents.⁴ Some municipalities have even tied local hire and

¹ California Workforce Development Board (2020) Putting California on the High Road: A Jobs and Climate Action Plan for 2030 at p. ii, *available at* <https://laborcenter.berkeley.edu/wp-content/uploads/2020/09/Putting-California-on-the-High-Road.pdf>.

² South Coast Air Quality Management District (May 7, 2021) Certify Final Environmental Assessment and Adopt Proposed Rule 2305 – Warehouse Indirect Source Rule – Warehouse Actions and Investments to Reduce Emissions Program, and Proposed Rule 316 – Fees for Rule 2305, Submit Rule 2305 for Inclusion Into the SIP, and Approve Supporting Budget Actions, *available at* <http://www.aqmd.gov/docs/default-source/Agendas/Governing-Board/2021/2021-May7-027.pdf?sfvrsn=10>.

³ California Planning Roundtable (2008) Deconstructing Jobs-Housing Balance at p. 6, *available at* <https://cproundtable.org/static/media/uploads/publications/cpr-jobs-housing.pdf>

⁴ Cervero, Robert and Duncan, Michael (2006) Which Reduces Vehicle Travel More: Jobs-Housing Balance or Retail-Housing Mixing? *Journal of the American Planning Association* 72 (4), 475-490, 482, *available at* <http://reconnectingamerica.org/assets/Uploads/UTCT-825.pdf>.

other workforce policies to local development permits to address transportation issues. Cervero and Duncan note that:

In nearly built-out Berkeley, CA, the approach to balancing jobs and housing is to create local jobs rather than to develop new housing. The city’s First Source program encourages businesses to hire local residents, especially for entry- and intermediate-level jobs, and sponsors vocational training to ensure residents are employment-ready. While the program is voluntary, some 300 businesses have used it to date, placing more than 3,000 city residents in local jobs since it was launched in 1986. When needed, these carrots are matched by sticks, since the city is not shy about negotiating corporate participation in First Source as a condition of approval for development permits.

Recently, the State of California verified its commitment towards workforce development through the Affordable Housing and High Road Jobs Act of 2022, otherwise known as Assembly Bill No. 2011 (“**AB2011**”). AB2011 amended the Planning and Zoning Law to allow ministerial, by-right approval for projects being built alongside commercial corridors that meet affordability and labor requirements.

The City should consider utilizing local workforce policies and requirements to benefit the local area economically and to mitigate greenhouse gas, improve air quality, and reduce transportation impacts.

II. THE CITY SHOULD IMPOSE TRAINING REQUIREMENTS FOR THE PROJECT’S CONSTRUCTION ACTIVITIES TO PREVENT COMMUNITY SPREAD OF COVID-19 AND OTHER INFECTIOUS DISEASES

Construction work has been defined as a Lower to High-risk activity for COVID-19 spread by the Occupational Safety and Health Administration. Recently, several construction sites have been identified as sources of community spread of COVID-19.⁵

⁵ Santa Clara County Public Health (June 12, 2020) COVID-19 CASES AT CONSTRUCTION SITES HIGHLIGHT NEED FOR CONTINUED VIGILANCE IN SECTORS THAT HAVE REOPENED, *available at* <https://www.sccgov.org/sites/covid19/Pages/press-release-06-12-2020-cases-at-construction-sites.aspx>.

Southwest Mountain States Carpenters recommend that the City adopt additional requirements to mitigate public health risks from the Project's construction activities. SWMSRCC requests that the City require safe on-site construction work practices as well as training and certification for any construction workers on the Project Site.

In particular, based upon Southwest Mountain States Carpenters' experience with safe construction site work practices, SWMSRCC recommends that the City require that while construction activities are being conducted at the Project Site:

Construction Site Design:

- The Project Site will be limited to two controlled entry points.
- Entry points will have temperature screening technicians taking temperature readings when the entry point is open.
- The Temperature Screening Site Plan shows details regarding access to the Project Site and Project Site logistics for conducting temperature screening.
- A 48-hour advance notice will be provided to all trades prior to the first day of temperature screening.
- The perimeter fence directly adjacent to the entry points will be clearly marked indicating the appropriate 6-foot social distancing position for when you approach the screening area. Please reference the Apex temperature screening site map for additional details.
- There will be clear signage posted at the project site directing you through temperature screening.
- Provide hand washing stations throughout the construction site.

Testing Procedures:

- The temperature screening being used are non-contact devices.
- Temperature readings will not be recorded.

- Personnel will be screened upon entering the testing center and should only take 1-2 seconds per individual.
- Hard hats, head coverings, sweat, dirt, sunscreen or any other cosmetics must be removed on the forehead before temperature screening.
- Anyone who refuses to submit to a temperature screening or does not answer the health screening questions will be refused access to the Project Site.
- Screening will be performed at both entrances from 5:30 am to 7:30 am.; main gate [ZONE 1] and personnel gate [ZONE 2]
- After 7:30 am only the main gate entrance [ZONE 1] will continue to be used for temperature testing for anybody gaining entry to the project site such as returning personnel, deliveries, and visitors.
- If the digital thermometer displays a temperature reading above 100.0 degrees Fahrenheit, a second reading will be taken to verify an accurate reading.
- If the second reading confirms an elevated temperature, DHS will instruct the individual that he/she will not be allowed to enter the Project Site. DHS will also instruct the individual to promptly notify his/her supervisor and his/her human resources (HR) representative and provide them with a copy of Annex A.

Planning

- Require the development of an Infectious Disease Preparedness and Response Plan that will include basic infection prevention measures (requiring the use of personal protection equipment), policies and procedures for prompt identification and isolation of sick individuals, social distancing (prohibiting gatherings of no more than 10 people including all-hands meetings and all-hands lunches)

communication and training and workplace controls that meet standards that may be promulgated by the Center for Disease Control, Occupational Safety and Health Administration, Cal/OSHA, California Department of Public Health or applicable local public health agencies.⁶

The United Brotherhood of Carpenters and Carpenters International Training Fund has developed COVID-19 Training and Certification to ensure that Carpenter union members and apprentices conduct safe work practices. The City should require that all construction workers undergo COVID-19 Training and Certification before being allowed to conduct construction activities at the Project Site.

Southwest Mountain States Carpenters has also developed a rigorous Infection Control Risk Assessment (“**ICRA**”) training program to ensure it delivers a workforce that understands how to identify and control infection risks by implementing protocols to protect themselves and all others during renovation and construction projects in healthcare environments.⁷

ICRA protocols are intended to contain pathogens, control airflow, and protect patients during the construction, maintenance and renovation of healthcare facilities. ICRA protocols prevent cross contamination, minimizing the risk of secondary infections in patients at hospital facilities.

The City should require the Project to be built using a workforce trained in ICRA protocols.

III. THE CITY SHOULD PREPARE AN ENVIRONMENTAL IMPACT REPORT FOR THE PROJECT

CEQA is a California statute designed to inform decision makers and the public about the potential, significant environmental effects of a project. 14 California Code of

⁶ See also The Center for Construction Research and Training, North America’s Building Trades Unions (April 27 2020) NABTU and CPWR COVID-19 Standards for U.S. Construction Sites, available at https://www.cpwr.com/sites/default/files/NABTU_CPWR_Standards_COVID-19.pdf; Los Angeles County Department of Public Works (2020) Guidelines for Construction Sites During COVID-19 Pandemic, available at https://dpw.lacounty.gov/building-and-safety/docs/pw_guidelines-construction-sites.pdf.

⁷ For details concerning Southwest Carpenters’s ICRA training program, see <https://icrahealthcare.com/>.

Regulations (“**CEQA Guidelines**”) § 15002(a)(1).⁸ At its core, “[i]ts purpose is to inform the public and its responsible officials of the environmental consequences of their decisions *before* they are made.” *Citizens of Goleta Valley v. Board of Supervisors* (1990) 52 Cal. 3d 553, 564.

To achieve this purpose, CEQA mandates preparation of an Environmental Impact Report (“**EIR**”) for projects so that the foreseeable impacts of pursuing the project can be understood and weighed. *Communities for a Better Environment v. Richmond* (2010) 184 Cal. App. 4th 70, 80. The EIR requirement “is the heart of CEQA.” CEQA Guidelines, § 15003(a).

A strong presumption in favor of requiring preparation of an EIR is built into CEQA. This presumption is reflected in what is known as the "fair argument" standard, under which an agency must prepare an EIR whenever substantial evidence in the record supports a fair argument that a project may have a significant effect on the environment. *Quail Botanical Gardens Found., Inc. v. City of Encinitas* (1994) 29 Cal. App. 4th 1597, 1602; *Friends of "B" St. v. City of Hayward* (1980) 106 Cal. 3d 988, 1002.

The fair argument test stems from the statutory mandate that an EIR be prepared for any project that "may have a significant effect on the environment." Public Resources Code (“**PRC**”) § 21151; *No Oil, Inc. v. City of Los Angeles* (1974) 13 Cal. App. 3d 68, 75; *Jensen v. City of Santa Rosa* (2018) 23 Cal. App. 5th 877, 884. Under this test, if a proposed project is not exempt and may cause a significant effect on the environment, the lead agency must prepare an EIR. PRC §§ 21100(a), 21151; CEQA Guidelines § 15064(a)(1), (f)(1). An EIR may be dispensed with only if the lead agency finds no substantial evidence in the initial study or elsewhere in the record that the project may have a significant effect on the environment. *Parker Shattuck Neighbors v. Berkeley City Council* (2013) 222 Cal. App. 4th 768, 785. In such a situation, the agency must adopt a negative declaration. PRC § 21080(c)(1); CEQA Guidelines §§ 15063(b)(2), 15064(f)(3).

⁸ The CEQA Guidelines, codified in Title 14 of the California Code of Regulations, section 15000 *et seq.*, are regulatory guidelines promulgated by the state Natural Resources Agency for the implementation of CEQA. (Cal. Pub. Res. Code § 21083.) The CEQA Guidelines are given “great weight in interpreting CEQA except when . . . clearly unauthorized or erroneous.” *Center for Biological Diversity v. Department of Fish & Wildlife* (2015) 62 Cal. 4th 204, 217.

"Significant effect upon the environment" is defined as "a substantial or potentially substantial adverse change in the environment." PRC § 21068; CEQA Guidelines § 15382. A project "may" have a significant effect on the environment if there is a "reasonable probability" that it will result in a significant impact. *No Oil, Inc. v. City of Los Angeles*, 13 Cal. 3d at 83 fn. 16; *Sundstrom v. County of Mendocino* (1988) 202 Cal. App. 3d 296, 309. If any aspect of the project may result in a significant impact on the environment, an EIR must be prepared even if the overall effect of the project is beneficial. CEQA Guidelines § 15063(b)(1). See *County Sanitation Dist. No. 2 v. County of Kern* (2005) 127 Cal. App. 4th 1544, 1580.

This standard sets a "low threshold" for preparation of an EIR. *Consolidated Irrig. Dist. v. City of Selma* (2012) 204 Cal. App. 4th 187, 207; *Nelson v. County of Kern* (2010) 190 Cal. App. 4th 252; *Pocket Protectors v. City of Sacramento* (2004) 124 Cal. App. 4th 903, 928; *Bowman v. City of Berkeley* (2004) 122 Cal. App. 4th 572, 580; *Citizen Action to Serve All Students v. Thornley* (1990) 222 Cal. App. 3d 748, 754; *Sundstrom v. County of Mendocino* (1988) 202 Cal. App. 3d 296, 310. If substantial evidence in the record supports a fair argument that the project may have a significant environmental effect, the lead agency must prepare an EIR even if other substantial evidence before it indicates the project will have no significant effect. See *Jensen v. City of Santa Rosa* (2018) 23 Cal. App. 5th 877, 886; *Clews Land & Livestock v. City of San Diego* (2017) 19 Cal. App. 5th 161, 183; *Stanislaus Audubon Soc'y, Inc. v. County of Stanislaus* (1995) 33 Cal. App. 4th 144, 150; *Brentwood Ass'n for No Drilling, Inc. v. City of Los Angeles* (1982) 134 Cal. App. 3d 491; *Friends of "B" St. v. City of Hayward* (1980) 106 Cal. App. 3d 988; CEQA Guidelines § 15064(f)(1).

As there is a fair argument that the Project may cause significant environmental impacts, as explained below, the low threshold is met and the City should prepare an EIR for the Project.

IV. THE CITY SHOULD DETERMINE THAT THE PROJECT DOES NOT QUALIFY FOR THE CLASS 32 CEQA EXEMPTION

CEQA exemptions must be construed narrowly. See *County of Amador v. El Dorado County Water Agency* (1999) 76 Cal.App.4th 931, 966. With regard to Class 32 exemptions for in-fill development projects, the project must meet all of the conditions identified in CEQA Guidelines section 15332, as follows:

- (a) The project is consistent with the applicable general plan designation and all applicable general plan policies as well as with applicable zoning designation and regulations;
- (b) The proposed development occurs within city limits on a project site of no more than five acres substantially surrounded by urban uses;
- (c) The project site has no value, as habitat for endangered, rare or threatened species;
- (d) Approval of the project would not result in any significant effects relating to traffic, noise, air quality, or water quality; and
- (e) The site can be adequately served by all required utilities and public services.

Moreover, categorical exemptions are not absolute. Even if a project fits into a categorical exemption class, the agency must consider whether a codified exception to exemption applies. Guidelines § 15300.2. A project falling within a categorical exemption may require environmental review if the project is subject to exceptions-to-the-exemptions listed under CEQA Guidelines § 15300.2, which include projects involving: (a) locations involving environmental resources of hazardous or critical concern; (b) significant cumulative impact of successive projects of the same type in the same place; (c) reasonable possibility of significant environmental effect due to unusual circumstances; (d) damage to scenic resources on State scenic highways; (e) locations listed as a hazardous waste site; or (f) substantial adverse changes to a historical resource.

Here, the Project fails to comply with all the required conditions. Therefore, the Project does not qualify for the Class 32 CEQA exemption.

A. The Project Is Inconsistent with the General Plan

Each California city and county must adopt a comprehensive, long-term general plan governing development. *Napa Citizens for Honest Gov. v. Napa County Bd. of Supervisors* (2001) 91 Cal.App.4th 342, 352, citing Gov. Code §§ 65030, 65300. The general plan sits at the top of the land use planning hierarchy, and serves as a “constitution” or “charter” for all future development. *DeVita v. County of Napa* (1995) 9 Cal.4th 763, 773; *Leshar Communications, Inc. v. City of Walnut Creek* (1990) 52 Cal.3d 531, 540.

General plan consistency is “the linchpin of California’s land use and development laws; it is the principle which infused the concept of planned growth with the force of law.” *Debottari v. Norco City Council* (1985) 171 Cal.App.3d 1204, 1213. It is well established that development projects may not be approved if they interfere with, or frustrate, the general plan’s policies and objectives. See *Napa Citizens*, 91 Cal.App.4th at 378-79; see also *Lesher*, 52 Cal.3d at 544.

Here, the Project requests numerous departures from the ordinary limits permitted by the General Plan and zoning designations, including but not limited to a density bonus, floor area ratio increase, side yard reduction, removal of the 36 feet height limitation “D”, at least three zoning administrator’s reviews (ZA), and one zoning injunction (ZI). (See, **Exhibit D** [LADBS Permit Info, as of 4/25/2023].) Specifically, the Project proposes construction of a 7-story, 87 ft tall, 137,640 sf mixed-use building, containing 151 residential units, 3,690 sf of commercial space, 20,565 sf of open space, and 87 parking spaces.

Further, per the City’s records, the Applicant has attempted to address the City’s corrections several times in 2022, but failed to clear even a single one to date. (*Id.*)

Also, per the 9/20/2022 EPS Intake Form Submission (produced by the City in response to our PRA requests), the Applicant not only seeks a density bonus, but also a conditional use permit to exceed the density bonus increase otherwise allowed by the state density bonus law.

In addition, the Project is located in the Hollywood Community Plan Area, which is still subject to the zoning injunction, including injunction against the removal of “D” height and other density/intensity limitations the City’s 2012 Hollywood Community Plan Update sought, but the Court set it aside; the new Hollywood Community Plan Update is not final and applicable.⁹ The Community plan is part of the City’s General Plan, and the Project must comply with its requirements, but manifestly does not.

Moreover, given the number of deviations the Project Applicant seeks, it far exceeds the number of incentives and concessions under the State Density Bonus Law.

Thus, given that the incentives and conditional use permit have not yet been approved (and potentially would be impossible to approve) and they far exceed the number of allowable density increase or incentives under the state law or zoning regulations,

⁹ See April 2, 2014 ZI No. 2433 [Revised Hollywood Community Plan Injunction], <http://zimas.lacity.org/documents/zoneinfo/ZI2433.pdf>

there is a colorful argument that the Project is inconsistent with the General Plan and all applicable zoning regulations, rendering it ineligible for a Class 32 CEQA exemption.¹⁰

B. The Project May Have Significant Environmental Effects

CEQA exemptions are reserved for projects without potential to have significant environmental effects. See *Salmon Protection & Watershed Network v. County of Marin* (2004) 125 Cal.App.4th 1098, 1107 [“If a project may have a significant effect on the environment, CEQA review must occur”]. The Project at hand has the potential to cause a number of significant environmental effects, which the proposed findings for the Project fail to address whatsoever let alone attempt to analyze.¹¹

The very nature of the Project, i.e. constructing a 7-story mixed-use residential building in place of a retail store with less intensity (Goodwill), creates potentially significant traffic, air quality, and noise issues stemming from the sheer increase in density and intensity of land use on the Project site. Coupled with the fact that the construction of the Project may involve road closures, street detours, and loud construction equipment, the Project has the potential to cause significant traffic, air quality, and noise impacts.

Further, these impacts may be more significant since, per the building permit information (see, Exhibit D), the Project seeks construction within easement, adjacent to public way, next to power lines, and encroaches in public way. To the extent the Project’s staging of heavy construction equipment may foreseeably occur in the public easement area and on top of utility connections, the Project may also have a significant impact on public utilities, traffic and circulation. This may well translate into more air quality, greenhouse gas emissions, noise and other traffic-related impacts.

¹⁰ See LA Department of Building & Safety Project Permit information [noting that the Density Bonus has not yet been cleared], available at <https://www.ladbsservices2.lacity.org/OnlineServices/PermitReport/PCISPermitDetail?id1=22010&id2=10000&id3=05021>.

¹¹ See Project Proposed Findings, available at <https://planning.lacity.org/pdiscaseinfo/document/NDEyNjE0/532f8e86-06a9-44b1-8001-06cd07316c90/esubmit>.

Without any Project-specific analysis quantifying the Project’s anticipated traffic, air quality, and noise impacts, the assertion that the Project will not have any significant impacts is merely speculative. Thus, the Class 32 CEQA exemption is inapplicable.

C. There Is No Evidence that The Project Site Can Be Adequately Served by All Required Utilities and Public Services.

Under CEQA Guidelines section 15332(d), there must be evidence that the Project site can be adequately served by all required utilities and public services. Here, there is no evidence that the Project site is equipped to handle the additional energy, water, and waste consumption of 151 new residential units in place of a retail store. In fact, the evidence points to the opposite conclusion since the sewer availability and waste drainage subsections of the Project permit have not yet been cleared by the Bureau of Engineering.¹² Accordingly, the Project must not qualify for the Class 32 exemption.

D. The Project May Be Subject to Exceptions to the Class 32 Exemption

Pursuant to CEQA Guidelines section 15300.2(c), “a categorical exemption shall not be used for an activity where there is a reasonable possibility that the activity will have a significant effect on the environment due to unusual circumstances.” Here, given the Project’s plan to demolish several former retail stores, excavate more than 5 feet deep, and construct a building over 36 feet tall, the Project presents unusual circumstances, with the possibility to result in significant environmental effects.¹³

Similarly, pursuant to CEQA Guidelines section 15300.2(b), all exemptions “are inapplicable when the cumulative impact of successive projects of the same type in the same place, over time is significant.” Here, there are several similar mixed-use building projects being proposed or constructed directly near the Project which may result in cumulative impacts. For example, there is an 8-story office and retail building proposed at 1235 N. Vine Street¹⁴; a 3-story office and retail complex proposed at 1200 N. Cahuenga Blvd.¹⁵; and a recently developed 7-story mixed-use residential

¹² See LA Department of Building & Safety Project Permit information, *available at* <https://www.ladbsservices2.lacity.org/OnlineServices/PermitReport/PCISPermitDetail?id1=22010&id2=10000&id3=05021>.

¹³ *Id.*

¹⁴ Eight-Story Office Building Planned Near Fountain & Vine (Mar. 2020), *available at* <https://la.urbanize.city/post/eight-story-office-building-planned-near-fountain-vine>

¹⁵ 75,000sf office complex planned for Cahuenga Boulevard (Dec. 2021), *available at* <https://la.urbanize.city/post/75000sf-office-complex-planned-cahuenga-boulevard>.

building at 1311 N. Cahuenga Blvd.¹⁶, all of which are less than 0.5 miles away from the Project.

The Project, along with these and other nearby projects, may collectively contribute to potentially significant cumulative impacts on air quality, noise, and traffic congestion in the neighborhood.

For these reasons too, the Class 23 CEQA exemption is not applicable since the exceptions under CEQA Guidelines section 15300.2 apply.¹⁷

V. CONCLUSION

In sum, SMSWRCC requests that the City require a local workforce, that the City impose training requirements for the Project's construction activities to prevent community spread of COVID-19 and other infectious diseases, and that the City prepare an EIR for the Project and determine that the Project does not qualify for a Class 32 CEQA exemption for the aforementioned concerns. If the City has any questions, feel free to contact my Office.

Sincerely,

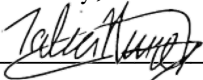

Talia Nimmer

Attorneys for Southwest Mountain States Regional Council of Carpenters

Attached:

Exhibit A: March 8, 2021 SWAPE Letter to Mitchell M. Tsai re Local Hire Requirements and Considerations for Greenhouse Gas Modeling;

Exhibit B: Air Quality and GHG Expert Paul Rosenfeld CV;

Exhibit C: Air Quality and GHG Expert Matt Hagemann CV; and

¹⁶ The Rise,

https://risehollywood.com/?campaignid=10679610387&adgroupid=104161672014&creative=452225925322&matchtype=p&network=g&device=c&keyword=the%20rise%20hollywood&gclid=CjwKCAjw_ihBhADEiwAXEazJgLbYKq1HvVREvWxOJ1Xw_T6yK21i38a_NBjT0tAKRoO3e2_o6MS3RoCPzQQAvD_BwE.

¹⁷ Per the Building Permits Info (Exhibit D), the Project's activities will occur next to trees in parkway. As such, depending on the type and size of trees and whether they are protected or not, the Project may have an impact on biological resources and thereby make the Class 32 exemption improper or otherwise trigger an unusual circumstances exception.

Exhibit D: LADBS Permit Information, as of 4/25/2023.

EXHIBIT A



Technical Consultation, Data Analysis and
Litigation Support for the Environment

2656 29th Street, Suite 201
Santa Monica, CA 90405

Matt Hagemann, P.G, C.Hg.
(949) 887-9013
mhagemann@swape.com

Paul E. Rosenfeld, PhD
(310) 795-2335
prosenfeld@swape.com

March 8, 2021

Mitchell M. Tsai
155 South El Molino, Suite 104
Pasadena, CA 91101

Subject: Local Hire Requirements and Considerations for Greenhouse Gas Modeling

Dear Mr. Tsai,

Soil Water Air Protection Enterprise (“SWAPE”) is pleased to provide the following draft technical report explaining the significance of worker trips required for construction of land use development projects with respect to the estimation of greenhouse gas (“GHG”) emissions. The report will also discuss the potential for local hire requirements to reduce the length of worker trips, and consequently, reduced or mitigate the potential GHG impacts.

Worker Trips and Greenhouse Gas Calculations

The California Emissions Estimator Model (“CalEEMod”) is a “statewide land use emissions computer model designed to provide a uniform platform for government agencies, land use planners, and environmental professionals to quantify potential criteria pollutant and greenhouse gas (GHG) emissions associated with both construction and operations from a variety of land use projects.”¹ CalEEMod quantifies construction-related emissions associated with land use projects resulting from off-road construction equipment; on-road mobile equipment associated with workers, vendors, and hauling; fugitive dust associated with grading, demolition, truck loading, and on-road vehicles traveling along paved and unpaved roads; and architectural coating activities; and paving.²

The number, length, and vehicle class of worker trips are utilized by CalEEMod to calculate emissions associated with the on-road vehicle trips required to transport workers to and from the Project site during construction.³

¹ “California Emissions Estimator Model.” CAPCOA, 2017, available at: <http://www.aqmd.gov/caleemod/home>.

² “California Emissions Estimator Model.” CAPCOA, 2017, available at: <http://www.aqmd.gov/caleemod/home>.

³ “CalEEMod User’s Guide.” CAPCOA, November 2017, available at: http://www.aqmd.gov/docs/default-source/caleemod/01_user-39-s-guide2016-3-2_15november2017.pdf?sfvrsn=4, p. 34.

Specifically, the number and length of vehicle trips is utilized to estimate the vehicle miles travelled (“VMT”) associated with construction. Then, utilizing vehicle-class specific EMFAC 2014 emission factors, CalEEMod calculates the vehicle exhaust, evaporative, and dust emissions resulting from construction-related VMT, including personal vehicles for worker commuting.⁴

Specifically, in order to calculate VMT, CalEEMod multiplies the average daily trip rate by the average overall trip length (see excerpt below):

$$\text{“VMT}_d = \Sigma(\text{Average Daily Trip Rate}_i * \text{Average Overall Trip Length}_i)_n$$

Where:

n = Number of land uses being modeled.”⁵

Furthermore, to calculate the on-road emissions associated with worker trips, CalEEMod utilizes the following equation (see excerpt below):

$$\text{“Emissions}_{\text{pollutant}} = \text{VMT} * \text{EF}_{\text{running,pollutant}}$$

Where:

$\text{Emissions}_{\text{pollutant}}$ = emissions from vehicle running for each pollutant

VMT = vehicle miles traveled

$\text{EF}_{\text{running,pollutant}}$ = emission factor for running emissions.”⁶

Thus, there is a direct relationship between trip length and VMT, as well as a direct relationship between VMT and vehicle running emissions. In other words, when the trip length is increased, the VMT and vehicle running emissions increase as a result. Thus, vehicle running emissions can be reduced by decreasing the average overall trip length, by way of a local hire requirement or otherwise.

Default Worker Trip Parameters and Potential Local Hire Requirements

As previously discussed, the number, length, and vehicle class of worker trips are utilized by CalEEMod to calculate emissions associated with the on-road vehicle trips required to transport workers to and from the Project site during construction.⁷ In order to understand how local hire requirements and associated worker trip length reductions impact GHG emissions calculations, it is important to consider the CalEEMod default worker trip parameters. CalEEMod provides recommended default values based on site-specific information, such as land use type, meteorological data, total lot acreage, project type and typical equipment associated with project type. If more specific project information is known, the user can change the default values and input project-specific values, but the California Environmental Quality Act (“CEQA”) requires that such changes be justified by substantial evidence.⁸ The default number of construction-related worker trips is calculated by multiplying the

⁴ “Appendix A Calculation Details for CalEEMod.” CAPCOA, October 2017, available at: http://www.aqmd.gov/docs/default-source/caleemod/02_appendix-a2016-3-2.pdf?sfvrsn=6, p. 14-15.

⁵ “Appendix A Calculation Details for CalEEMod.” CAPCOA, October 2017, available at: http://www.aqmd.gov/docs/default-source/caleemod/02_appendix-a2016-3-2.pdf?sfvrsn=6, p. 23.

⁶ “Appendix A Calculation Details for CalEEMod.” CAPCOA, October 2017, available at: http://www.aqmd.gov/docs/default-source/caleemod/02_appendix-a2016-3-2.pdf?sfvrsn=6, p. 15.

⁷ “CalEEMod User’s Guide.” CAPCOA, November 2017, available at: http://www.aqmd.gov/docs/default-source/caleemod/01_user-39-s-guide2016-3-2_15november2017.pdf?sfvrsn=4, p. 34.

⁸ CalEEMod User Guide, available at: <http://www.caleemod.com/>, p. 1, 9.

number of pieces of equipment for all phases by 1.25, with the exception of worker trips required for the building construction and architectural coating phases.⁹ Furthermore, the worker trip vehicle class is a 50/25/25 percent mix of light duty autos, light duty truck class 1 and light duty truck class 2, respectively.”¹⁰ Finally, the default worker trip length is consistent with the length of the operational home-to-work vehicle trips.¹¹ The operational home-to-work vehicle trip lengths are:

“[B]ased on the *location* and *urbanization* selected on the project characteristic screen. These values were *supplied by the air districts or use a default average for the state*. Each district (or county) also assigns trip lengths for urban and rural settings” (emphasis added).¹²

Thus, the default worker trip length is based on the location and urbanization level selected by the User when modeling emissions. The below table shows the CalEEMod default rural and urban worker trip lengths by air basin (see excerpt below and Attachment A).¹³

Worker Trip Length by Air Basin		
Air Basin	Rural (miles)	Urban (miles)
Great Basin Valleys	16.8	10.8
Lake County	16.8	10.8
Lake Tahoe	16.8	10.8
Mojave Desert	16.8	10.8
Mountain Counties	16.8	10.8
North Central Coast	17.1	12.3
North Coast	16.8	10.8
Northeast Plateau	16.8	10.8
Sacramento Valley	16.8	10.8
Salton Sea	14.6	11
San Diego	16.8	10.8
San Francisco Bay Area	10.8	10.8
San Joaquin Valley	16.8	10.8
South Central Coast	16.8	10.8
South Coast	19.8	14.7
Average	16.47	11.17
Minimum	10.80	10.80
Maximum	19.80	14.70
Range	9.00	3.90

⁹ “CalEEMod User’s Guide.” CAPCOA, November 2017, available at: http://www.aqmd.gov/docs/default-source/caleemod/01_user-39-s-guide2016-3-2_15november2017.pdf?sfvrsn=4, p. 34.

¹⁰ “Appendix A Calculation Details for CalEEMod.” CAPCOA, October 2017, available at: http://www.aqmd.gov/docs/default-source/caleemod/02_appendix-a2016-3-2.pdf?sfvrsn=6, p. 15.

¹¹ “Appendix A Calculation Details for CalEEMod.” CAPCOA, October 2017, available at: http://www.aqmd.gov/docs/default-source/caleemod/02_appendix-a2016-3-2.pdf?sfvrsn=6, p. 14.

¹² “Appendix A Calculation Details for CalEEMod.” CAPCOA, October 2017, available at: http://www.aqmd.gov/docs/default-source/caleemod/02_appendix-a2016-3-2.pdf?sfvrsn=6, p. 21.

¹³ “Appendix D Default Data Tables.” CAPCOA, October 2017, available at: http://www.aqmd.gov/docs/default-source/caleemod/05_appendix-d2016-3-2.pdf?sfvrsn=4, p. D-84 – D-86.

As demonstrated above, default rural worker trip lengths for air basins in California vary from 10.8- to 19.8- miles, with an average of 16.47 miles. Furthermore, default urban worker trip lengths vary from 10.8- to 14.7- miles, with an average of 11.17 miles. Thus, while default worker trip lengths vary by location, default urban worker trip lengths tend to be shorter in length. Based on these trends evident in the CalEEMod default worker trip lengths, we can reasonably assume that the efficacy of a local hire requirement is especially dependent upon the urbanization of the project site, as well as the project location.

Practical Application of a Local Hire Requirement and Associated Impact

To provide an example of the potential impact of a local hire provision on construction-related GHG emissions, we estimated the significance of a local hire provision for the Village South Specific Plan (“Project”) located in the City of Claremont (“City”). The Project proposed to construct 1,000 residential units, 100,000-SF of retail space, 45,000-SF of office space, as well as a 50-room hotel, on the 24-acre site. The Project location is classified as Urban and lies within the Los Angeles-South Coast County. As a result, the Project has a default worker trip length of 14.7 miles.¹⁴ In an effort to evaluate the potential for a local hire provision to reduce the Project’s construction-related GHG emissions, we prepared an updated model, reducing all worker trip lengths to 10 miles (see Attachment B). Our analysis estimates that if a local hire provision with a 10-mile radius were to be implemented, the GHG emissions associated with Project construction would decrease by approximately 17% (see table below and Attachment C).

Local Hire Provision Net Change	
Without Local Hire Provision	
Total Construction GHG Emissions (MT CO ₂ e)	3,623
Amortized Construction GHG Emissions (MT CO ₂ e/year)	120.77
With Local Hire Provision	
Total Construction GHG Emissions (MT CO ₂ e)	3,024
Amortized Construction GHG Emissions (MT CO ₂ e/year)	100.80
% Decrease in Construction-related GHG Emissions	17%

As demonstrated above, by implementing a local hire provision requiring 10 mile worker trip lengths, the Project could reduce potential GHG emissions associated with construction worker trips. More broadly, any local hire requirement that results in a decreased worker trip length from the default value has the potential to result in a reduction of construction-related GHG emissions, though the significance of the reduction would vary based on the location and urbanization level of the project site.

This serves as an example of the potential impacts of local hire requirements on estimated project-level GHG emissions, though it does not indicate that local hire requirements would result in reduced construction-related GHG emission for all projects. As previously described, the significance of a local hire requirement depends on the worker trip length enforced and the default worker trip length for the project’s urbanization level and location.

¹⁴ “Appendix D Default Data Tables.” CAPCOA, October 2017, available at: http://www.aqmd.gov/docs/default-source/caleemod/05_appendix-d2016-3-2.pdf?sfvrsn=4, p. D-85.

Disclaimer

SWAPE has received limited discovery. Additional information may become available in the future; thus, we retain the right to revise or amend this report when additional information becomes available. Our professional services have been performed using that degree of care and skill ordinarily exercised, under similar circumstances, by reputable environmental consultants practicing in this or similar localities at the time of service. No other warranty, expressed or implied, is made as to the scope of work, work methodologies and protocols, site conditions, analytical testing results, and findings presented. This report reflects efforts which were limited to information that was reasonably accessible at the time of the work, and may contain informational gaps, inconsistencies, or otherwise be incomplete due to the unavailability or uncertainty of information obtained or provided by third parties.

Sincerely,

A handwritten signature in blue ink that reads "Matt Hagemann". The signature is fluid and cursive.

Matt Hagemann, P.G., C.Hg.

A handwritten signature in blue ink that reads "Paul Rosenfeld". The signature is fluid and cursive.

Paul E. Rosenfeld, Ph.D.

Attachment A

Location Type	Location Name	Rural H-W (miles)	Urban H-W (miles)
Air Basin	Great Basin	16.8	10.8
Air Basin	Lake County	16.8	10.8
Air Basin	Lake Tahoe	16.8	10.8
Air Basin	Mojave Desert	16.8	10.8
Air Basin	Mountain	16.8	10.8
Air Basin	North Central	17.1	12.3
Air Basin	North Coast	16.8	10.8
Air Basin	Northeast	16.8	10.8
Air Basin	Sacramento	16.8	10.8
Air Basin	Salton Sea	14.6	11
Air Basin	San Diego	16.8	10.8
Air Basin	San Francisco	10.8	10.8
Air Basin	San Joaquin	16.8	10.8
Air Basin	South Central	16.8	10.8
Air Basin	South Coast	19.8	14.7
Air District	Amador County	16.8	10.8
Air District	Antelope Valley	16.8	10.8
Air District	Bay Area AQMD	10.8	10.8
Air District	Butte County	12.54	12.54
Air District	Calaveras	16.8	10.8
Air District	Colusa County	16.8	10.8
Air District	El Dorado	16.8	10.8
Air District	Feather River	16.8	10.8
Air District	Glenn County	16.8	10.8
Air District	Great Basin	16.8	10.8
Air District	Imperial County	10.2	7.3
Air District	Kern County	16.8	10.8
Air District	Lake County	16.8	10.8
Air District	Lassen County	16.8	10.8
Air District	Mariposa	16.8	10.8
Air District	Mendocino	16.8	10.8
Air District	Modoc County	16.8	10.8
Air District	Mojave Desert	16.8	10.8
Air District	Monterey Bay	16.8	10.8
Air District	North Coast	16.8	10.8
Air District	Northern Sierra	16.8	10.8
Air District	Northern	16.8	10.8
Air District	Placer County	16.8	10.8
Air District	Sacramento	15	10

Air District	San Diego	16.8	10.8
Air District	San Joaquin	16.8	10.8
Air District	San Luis Obispo	13	13
Air District	Santa Barbara	8.3	8.3
Air District	Shasta County	16.8	10.8
Air District	Siskiyou County	16.8	10.8
Air District	South Coast	19.8	14.7
Air District	Tehama County	16.8	10.8
Air District	Tuolumne	16.8	10.8
Air District	Ventura County	16.8	10.8
Air District	Yolo/Solano	15	10
County	Alameda	10.8	10.8
County	Alpine	16.8	10.8
County	Amador	16.8	10.8
County	Butte	12.54	12.54
County	Calaveras	16.8	10.8
County	Colusa	16.8	10.8
County	Contra Costa	10.8	10.8
County	Del Norte	16.8	10.8
County	El Dorado-Lake	16.8	10.8
County	El Dorado-	16.8	10.8
County	Fresno	16.8	10.8
County	Glenn	16.8	10.8
County	Humboldt	16.8	10.8
County	Imperial	10.2	7.3
County	Inyo	16.8	10.8
County	Kern-Mojave	16.8	10.8
County	Kern-San	16.8	10.8
County	Kings	16.8	10.8
County	Lake	16.8	10.8
County	Lassen	16.8	10.8
County	Los Angeles-	16.8	10.8
County	Los Angeles-	19.8	14.7
County	Madera	16.8	10.8
County	Marin	10.8	10.8
County	Mariposa	16.8	10.8
County	Mendocino-	16.8	10.8
County	Mendocino-	16.8	10.8
County	Mendocino-	16.8	10.8
County	Mendocino-	16.8	10.8
County	Merced	16.8	10.8
County	Modoc	16.8	10.8
County	Mono	16.8	10.8
County	Monterey	16.8	10.8
County	Napa	10.8	10.8

County	Nevada	16.8	10.8
County	Orange	19.8	14.7
County	Placer-Lake	16.8	10.8
County	Placer-Mountain	16.8	10.8
County	Placer-	16.8	10.8
County	Plumas	16.8	10.8
County	Riverside-	16.8	10.8
County	Riverside-	19.8	14.7
County	Riverside-Salton	14.6	11
County	Riverside-South	19.8	14.7
County	Sacramento	15	10
County	San Benito	16.8	10.8
County	San Bernardino-	16.8	10.8
County	San Bernardino-	19.8	14.7
County	San Diego	16.8	10.8
County	San Francisco	10.8	10.8
County	San Joaquin	16.8	10.8
County	San Luis Obispo	13	13
County	San Mateo	10.8	10.8
County	Santa Barbara-	8.3	8.3
County	Santa Barbara-	8.3	8.3
County	Santa Clara	10.8	10.8
County	Santa Cruz	16.8	10.8
County	Shasta	16.8	10.8
County	Sierra	16.8	10.8
County	Siskiyou	16.8	10.8
County	Solano-	15	10
County	Solano-San	16.8	10.8
County	Sonoma-North	16.8	10.8
County	Sonoma-San	10.8	10.8
County	Stanislaus	16.8	10.8
County	Sutter	16.8	10.8
County	Tehama	16.8	10.8
County	Trinity	16.8	10.8
County	Tulare	16.8	10.8
County	Tuolumne	16.8	10.8
County	Ventura	16.8	10.8
County	Yolo	15	10
County	Yuba	16.8	10.8
Statewide	Statewide	16.8	10.8

Worker Trip Length by Air Basin		
Air Basin	Rural (miles)	Urban (miles)
Great Basin Valleys	16.8	10.8
Lake County	16.8	10.8
Lake Tahoe	16.8	10.8
Mojave Desert	16.8	10.8
Mountain Counties	16.8	10.8
North Central Coast	17.1	12.3
North Coast	16.8	10.8
Northeast Plateau	16.8	10.8
Sacramento Valley	16.8	10.8
Salton Sea	14.6	11
San Diego	16.8	10.8
San Francisco Bay Area	10.8	10.8
San Joaquin Valley	16.8	10.8
South Central Coast	16.8	10.8
South Coast	19.8	14.7
Average	16.47	11.17
Minimum	10.80	10.80
Maximum	19.80	14.70
Range	9.00	3.90

Village South Specific Plan (Proposed) - Los Angeles-South Coast County, Annual

Village South Specific Plan (Proposed)
Los Angeles-South Coast County, Annual

1.0 Project Characteristics

1.1 Land Usage

Land Uses	Size	Metric	Lot Acreage	Floor Surface Area	Population
General Office Building	45.00	1000sqft	1.03	45,000.00	0
High Turnover (Sit Down Restaurant)	36.00	1000sqft	0.83	36,000.00	0
Hotel	50.00	Room	1.67	72,600.00	0
Quality Restaurant	8.00	1000sqft	0.18	8,000.00	0
Apartments Low Rise	25.00	Dwelling Unit	1.56	25,000.00	72
Apartments Mid Rise	975.00	Dwelling Unit	25.66	975,000.00	2789
Regional Shopping Center	56.00	1000sqft	1.29	56,000.00	0

1.2 Other Project Characteristics

Urbanization	Urban	Wind Speed (m/s)	2.2	Precipitation Freq (Days)	33
Climate Zone	9			Operational Year	2028
Utility Company	Southern California Edison				
CO2 Intensity (lb/MW hr)	702.44	CH4 Intensity (lb/MW hr)	0.029	N2O Intensity (lb/MW hr)	0.006

1.3 User Entered Comments & Non-Default Data

Village South Specific Plan (Proposed) - Los Angeles-South Coast County, Annual

Project Characteristics - Consistent with the DEIR's model.

Land Use - See SWAPE comment regarding residential and retail land uses.

Construction Phase - See SWAPE comment regarding individual construction phase lengths.

Demolition - Consistent with the DEIR's model. See SWAPE comment regarding demolition.

Vehicle Trips - Saturday trips consistent with the DEIR's model. See SWAPE comment regarding weekday and Sunday trips.

Woodstoves - Woodstoves and wood-burning fireplaces consistent with the DEIR's model. See SWAPE comment regarding gas fireplaces.

Energy Use -

Construction Off-road Equipment Mitigation - See SWAPE comment on construction-related mitigation.

Area Mitigation - See SWAPE comment regarding operational mitigation measures.

Water Mitigation - See SWAPE comment regarding operational mitigation measures.

Table Name	Column Name	Default Value	New Value
tblFireplaces	FireplaceWoodMass	1,019.20	0.00
tblFireplaces	FireplaceWoodMass	1,019.20	0.00
tblFireplaces	NumberWood	1.25	0.00
tblFireplaces	NumberWood	48.75	0.00
tblVehicleTrips	ST_TR	7.16	6.17
tblVehicleTrips	ST_TR	6.39	3.87
tblVehicleTrips	ST_TR	2.46	1.39
tblVehicleTrips	ST_TR	158.37	79.82
tblVehicleTrips	ST_TR	8.19	3.75
tblVehicleTrips	ST_TR	94.36	63.99
tblVehicleTrips	ST_TR	49.97	10.74
tblVehicleTrips	SU_TR	6.07	6.16
tblVehicleTrips	SU_TR	5.86	4.18
tblVehicleTrips	SU_TR	1.05	0.69
tblVehicleTrips	SU_TR	131.84	78.27

Village South Specific Plan (Proposed) - Los Angeles-South Coast County, Annual

tblVehicleTrips	SU_TR	5.95	3.20
tblVehicleTrips	SU_TR	72.16	57.65
tblVehicleTrips	SU_TR	25.24	6.39
tblVehicleTrips	WD_TR	6.59	5.83
tblVehicleTrips	WD_TR	6.65	4.13
tblVehicleTrips	WD_TR	11.03	6.41
tblVehicleTrips	WD_TR	127.15	65.80
tblVehicleTrips	WD_TR	8.17	3.84
tblVehicleTrips	WD_TR	89.95	62.64
tblVehicleTrips	WD_TR	42.70	9.43
tblWoodstoves	NumberCatalytic	1.25	0.00
tblWoodstoves	NumberCatalytic	48.75	0.00
tblWoodstoves	NumberNoncatalytic	1.25	0.00
tblWoodstoves	NumberNoncatalytic	48.75	0.00
tblWoodstoves	WoodstoveDayYear	25.00	0.00
tblWoodstoves	WoodstoveDayYear	25.00	0.00
tblWoodstoves	WoodstoveWoodMass	999.60	0.00
tblWoodstoves	WoodstoveWoodMass	999.60	0.00

2.0 Emissions Summary

Village South Specific Plan (Proposed) - Los Angeles-South Coast County, Annual

2.1 Overall Construction

Unmitigated Construction

	ROG	NOx	CO	SO2	Fugitive PM10	Exhaust PM10	PM10 Total	Fugitive PM2.5	Exhaust PM2.5	PM2.5 Total	Bio- CO2	NBio- CO2	Total CO2	CH4	N2O	CO2e
Year	tons/yr										MT/yr					
2021	0.1713	1.8242	1.1662	2.4000e-003	0.4169	0.0817	0.4986	0.1795	0.0754	0.2549	0.0000	213.1969	213.1969	0.0601	0.0000	214.6993
2022	0.6904	4.1142	6.1625	0.0189	1.3058	0.1201	1.4259	0.3460	0.1128	0.4588	0.0000	1,721.6826	1,721.6826	0.1294	0.0000	1,724.9187
2023	0.6148	3.3649	5.6747	0.0178	1.1963	0.0996	1.2959	0.3203	0.0935	0.4138	0.0000	1,627.5295	1,627.5295	0.1185	0.0000	1,630.4925
2024	4.1619	0.1335	0.2810	5.9000e-004	0.0325	6.4700e-003	0.0390	8.6300e-003	6.0400e-003	0.0147	0.0000	52.9078	52.9078	8.0200e-003	0.0000	53.1082
Maximum	4.1619	4.1142	6.1625	0.0189	1.3058	0.1201	1.4259	0.3460	0.1128	0.4588	0.0000	1,721.6826	1,721.6826	0.1294	0.0000	1,724.9187

Village South Specific Plan (Proposed) - Los Angeles-South Coast County, Annual

2.1 Overall Construction

Mitigated Construction

	ROG	NOx	CO	SO2	Fugitive PM10	Exhaust PM10	PM10 Total	Fugitive PM2.5	Exhaust PM2.5	PM2.5 Total	Bio- CO2	NBio- CO2	Total CO2	CH4	N2O	CO2e
Year	tons/yr										MT/yr					
2021	0.1713	1.8242	1.1662	2.4000e-003	0.4169	0.0817	0.4986	0.1795	0.0754	0.2549	0.0000	213.1967	213.1967	0.0601	0.0000	214.6991
2022	0.6904	4.1142	6.1625	0.0189	1.3058	0.1201	1.4259	0.3460	0.1128	0.4588	0.0000	1,721.6823	1,721.6823	0.1294	0.0000	1,724.9183
2023	0.6148	3.3648	5.6747	0.0178	1.1963	0.0996	1.2959	0.3203	0.0935	0.4138	0.0000	1,627.5291	1,627.5291	0.1185	0.0000	1,630.4921
2024	4.1619	0.1335	0.2810	5.9000e-004	0.0325	6.4700e-003	0.0390	8.6300e-003	6.0400e-003	0.0147	0.0000	52.9077	52.9077	8.0200e-003	0.0000	53.1082
Maximum	4.1619	4.1142	6.1625	0.0189	1.3058	0.1201	1.4259	0.3460	0.1128	0.4588	0.0000	1,721.6823	1,721.6823	0.1294	0.0000	1,724.9183

	ROG	NOx	CO	SO2	Fugitive PM10	Exhaust PM10	PM10 Total	Fugitive PM2.5	Exhaust PM2.5	PM2.5 Total	Bio- CO2	NBio-CO2	Total CO2	CH4	N2O	CO2e
Percent Reduction	0.00	0.00	0.00	0.00	0.00	0.00	0.00	0.00	0.00	0.00	0.00	0.00	0.00	0.00	0.00	0.00

Quarter	Start Date	End Date	Maximum Unmitigated ROG + NOX (tons/quarter)	Maximum Mitigated ROG + NOX (tons/quarter)
1	9-1-2021	11-30-2021	1.4103	1.4103
2	12-1-2021	2-28-2022	1.3613	1.3613
3	3-1-2022	5-31-2022	1.1985	1.1985
4	6-1-2022	8-31-2022	1.1921	1.1921
5	9-1-2022	11-30-2022	1.1918	1.1918
6	12-1-2022	2-28-2023	1.0774	1.0774
7	3-1-2023	5-31-2023	1.0320	1.0320
8	6-1-2023	8-31-2023	1.0260	1.0260

Village South Specific Plan (Proposed) - Los Angeles-South Coast County, Annual

9	9-1-2023	11-30-2023	1.0265	1.0265
10	12-1-2023	2-29-2024	2.8857	2.8857
11	3-1-2024	5-31-2024	1.6207	1.6207
		Highest	2.8857	2.8857

2.2 Overall Operational
Unmitigated Operational

	ROG	NOx	CO	SO2	Fugitive PM10	Exhaust PM10	PM10 Total	Fugitive PM2.5	Exhaust PM2.5	PM2.5 Total	Bio- CO2	NBio- CO2	Total CO2	CH4	N2O	CO2e
Category	tons/yr										MT/yr					
Area	5.1437	0.2950	10.3804	1.6700e-003		0.0714	0.0714		0.0714	0.0714	0.0000	220.9670	220.9670	0.0201	3.7400e-003	222.5835
Energy	0.1398	1.2312	0.7770	7.6200e-003		0.0966	0.0966		0.0966	0.0966	0.0000	3,896.0732	3,896.0732	0.1303	0.0468	3,913.2833
Mobile	1.5857	7.9962	19.1834	0.0821	7.7979	0.0580	7.8559	2.0895	0.0539	2.1434	0.0000	7,620.4986	7,620.4986	0.3407	0.0000	7,629.0162
Waste						0.0000	0.0000		0.0000	0.0000	207.8079	0.0000	207.8079	12.2811	0.0000	514.8354
Water						0.0000	0.0000		0.0000	0.0000	29.1632	556.6420	585.8052	3.0183	0.0755	683.7567
Total	6.8692	9.5223	30.3407	0.0914	7.7979	0.2260	8.0240	2.0895	0.2219	2.3114	236.9712	12,294.1807	12,531.1519	15.7904	0.1260	12,963.4751

Village South Specific Plan (Proposed) - Los Angeles-South Coast County, Annual

2.2 Overall Operational

Mitigated Operational

	ROG	NOx	CO	SO2	Fugitive PM10	Exhaust PM10	PM10 Total	Fugitive PM2.5	Exhaust PM2.5	PM2.5 Total	Bio- CO2	NBio- CO2	Total CO2	CH4	N2O	CO2e
Category	tons/yr										MT/yr					
Area	5.1437	0.2950	10.3804	1.6700e-003		0.0714	0.0714		0.0714	0.0714	0.0000	220.9670	220.9670	0.0201	3.7400e-003	222.5835
Energy	0.1398	1.2312	0.7770	7.6200e-003		0.0966	0.0966		0.0966	0.0966	0.0000	3,896.0732	3,896.0732	0.1303	0.0468	3,913.2833
Mobile	1.5857	7.9962	19.1834	0.0821	7.7979	0.0580	7.8559	2.0895	0.0539	2.1434	0.0000	7,620.4986	7,620.4986	0.3407	0.0000	7,629.0162
Waste						0.0000	0.0000		0.0000	0.0000	207.8079	0.0000	207.8079	12.2811	0.0000	514.8354
Water						0.0000	0.0000		0.0000	0.0000	29.1632	556.6420	585.8052	3.0183	0.0755	683.7567
Total	6.8692	9.5223	30.3407	0.0914	7.7979	0.2260	8.0240	2.0895	0.2219	2.3114	236.9712	12,294.1807	12,531.1519	15.7904	0.1260	12,963.4751

	ROG	NOx	CO	SO2	Fugitive PM10	Exhaust PM10	PM10 Total	Fugitive PM2.5	Exhaust PM2.5	PM2.5 Total	Bio- CO2	NBio- CO2	Total CO2	CH4	N2O	CO2e
Percent Reduction	0.00	0.00	0.00	0.00	0.00	0.00	0.00	0.00	0.00	0.00	0.00	0.00	0.00	0.00	0.00	0.00

3.0 Construction Detail

Construction Phase

Village South Specific Plan (Proposed) - Los Angeles-South Coast County, Annual

Phase Number	Phase Name	Phase Type	Start Date	End Date	Num Days Week	Num Days	Phase Description
1	Demolition	Demolition	9/1/2021	10/12/2021	5	30	
2	Site Preparation	Site Preparation	10/13/2021	11/9/2021	5	20	
3	Grading	Grading	11/10/2021	1/11/2022	5	45	
4	Building Construction	Building Construction	1/12/2022	12/12/2023	5	500	
5	Paving	Paving	12/13/2023	1/30/2024	5	35	
6	Architectural Coating	Architectural Coating	1/31/2024	3/19/2024	5	35	

Acres of Grading (Site Preparation Phase): 0

Acres of Grading (Grading Phase): 112.5

Acres of Paving: 0

Residential Indoor: 2,025,000; Residential Outdoor: 675,000; Non-Residential Indoor: 326,400; Non-Residential Outdoor: 108,800; Striped Parking Area: 0 (Architectural Coating – sqft)

OffRoad Equipment

Village South Specific Plan (Proposed) - Los Angeles-South Coast County, Annual

Phase Name	Offroad Equipment Type	Amount	Usage Hours	Horse Power	Load Factor
Demolition	Concrete/Industrial Saws	1	8.00	81	0.73
Demolition	Excavators	3	8.00	158	0.38
Demolition	Rubber Tired Dozers	2	8.00	247	0.40
Site Preparation	Rubber Tired Dozers	3	8.00	247	0.40
Site Preparation	Tractors/Loaders/Backhoes	4	8.00	97	0.37
Grading	Excavators	2	8.00	158	0.38
Grading	Graders	1	8.00	187	0.41
Grading	Rubber Tired Dozers	1	8.00	247	0.40
Grading	Scrapers	2	8.00	367	0.48
Grading	Tractors/Loaders/Backhoes	2	8.00	97	0.37
Building Construction	Cranes	1	7.00	231	0.29
Building Construction	Forklifts	3	8.00	89	0.20
Building Construction	Generator Sets	1	8.00	84	0.74
Building Construction	Tractors/Loaders/Backhoes	3	7.00	97	0.37
Building Construction	Welders	1	8.00	46	0.45
Paving	Pavers	2	8.00	130	0.42
Paving	Paving Equipment	2	8.00	132	0.36
Paving	Rollers	2	8.00	80	0.38
Architectural Coating	Air Compressors	1	6.00	78	0.48

Trips and VMT

Village South Specific Plan (Proposed) - Los Angeles-South Coast County, Annual

Phase Name	Offroad Equipment Count	Worker Trip Number	Vendor Trip Number	Hauling Trip Number	Worker Trip Length	Vendor Trip Length	Hauling Trip Length	Worker Vehicle Class	Vendor Vehicle Class	Hauling Vehicle Class
Demolition	6	15.00	0.00	458.00	14.70	6.90	20.00	LD_Mix	HDT_Mix	HHDT
Site Preparation	7	18.00	0.00	0.00	14.70	6.90	20.00	LD_Mix	HDT_Mix	HHDT
Grading	8	20.00	0.00	0.00	14.70	6.90	20.00	LD_Mix	HDT_Mix	HHDT
Building Construction	9	801.00	143.00	0.00	14.70	6.90	20.00	LD_Mix	HDT_Mix	HHDT
Paving	6	15.00	0.00	0.00	14.70	6.90	20.00	LD_Mix	HDT_Mix	HHDT
Architectural Coating	1	160.00	0.00	0.00	14.70	6.90	20.00	LD_Mix	HDT_Mix	HHDT

3.1 Mitigation Measures Construction

3.2 Demolition - 2021

Unmitigated Construction On-Site

	ROG	NOx	CO	SO2	Fugitive PM10	Exhaust PM10	PM10 Total	Fugitive PM2.5	Exhaust PM2.5	PM2.5 Total	Bio- CO2	NBio- CO2	Total CO2	CH4	N2O	CO2e
Category	tons/yr										MT/yr					
Fugitive Dust					0.0496	0.0000	0.0496	7.5100e-003	0.0000	7.5100e-003	0.0000	0.0000	0.0000	0.0000	0.0000	0.0000
Off-Road	0.0475	0.4716	0.3235	5.8000e-004		0.0233	0.0233		0.0216	0.0216	0.0000	51.0012	51.0012	0.0144	0.0000	51.3601
Total	0.0475	0.4716	0.3235	5.8000e-004	0.0496	0.0233	0.0729	7.5100e-003	0.0216	0.0291	0.0000	51.0012	51.0012	0.0144	0.0000	51.3601

Village South Specific Plan (Proposed) - Los Angeles-South Coast County, Annual

3.2 Demolition - 2021

Unmitigated Construction Off-Site

	ROG	NOx	CO	SO2	Fugitive PM10	Exhaust PM10	PM10 Total	Fugitive PM2.5	Exhaust PM2.5	PM2.5 Total	Bio- CO2	NBio- CO2	Total CO2	CH4	N2O	CO2e
Category	tons/yr										MT/yr					
Hauling	1.9300e-003	0.0634	0.0148	1.8000e-004	3.9400e-003	1.9000e-004	4.1300e-003	1.0800e-003	1.8000e-004	1.2600e-003	0.0000	17.4566	17.4566	1.2100e-003	0.0000	17.4869
Vendor	0.0000	0.0000	0.0000	0.0000	0.0000	0.0000	0.0000	0.0000	0.0000	0.0000	0.0000	0.0000	0.0000	0.0000	0.0000	0.0000
Worker	9.7000e-004	7.5000e-004	8.5100e-003	2.0000e-005	2.4700e-003	2.0000e-005	2.4900e-003	6.5000e-004	2.0000e-005	6.7000e-004	0.0000	2.2251	2.2251	7.0000e-005	0.0000	2.2267
Total	2.9000e-003	0.0641	0.0233	2.0000e-004	6.4100e-003	2.1000e-004	6.6200e-003	1.7300e-003	2.0000e-004	1.9300e-003	0.0000	19.6816	19.6816	1.2800e-003	0.0000	19.7136

Mitigated Construction On-Site

	ROG	NOx	CO	SO2	Fugitive PM10	Exhaust PM10	PM10 Total	Fugitive PM2.5	Exhaust PM2.5	PM2.5 Total	Bio- CO2	NBio- CO2	Total CO2	CH4	N2O	CO2e
Category	tons/yr										MT/yr					
Fugitive Dust					0.0496	0.0000	0.0496	7.5100e-003	0.0000	7.5100e-003	0.0000	0.0000	0.0000	0.0000	0.0000	0.0000
Off-Road	0.0475	0.4716	0.3235	5.8000e-004		0.0233	0.0233		0.0216	0.0216	0.0000	51.0011	51.0011	0.0144	0.0000	51.3600
Total	0.0475	0.4716	0.3235	5.8000e-004	0.0496	0.0233	0.0729	7.5100e-003	0.0216	0.0291	0.0000	51.0011	51.0011	0.0144	0.0000	51.3600

Village South Specific Plan (Proposed) - Los Angeles-South Coast County, Annual

3.2 Demolition - 2021

Mitigated Construction Off-Site

	ROG	NOx	CO	SO2	Fugitive PM10	Exhaust PM10	PM10 Total	Fugitive PM2.5	Exhaust PM2.5	PM2.5 Total	Bio- CO2	NBio- CO2	Total CO2	CH4	N2O	CO2e
Category	tons/yr										MT/yr					
Hauling	1.9300e-003	0.0634	0.0148	1.8000e-004	3.9400e-003	1.9000e-004	4.1300e-003	1.0800e-003	1.8000e-004	1.2600e-003	0.0000	17.4566	17.4566	1.2100e-003	0.0000	17.4869
Vendor	0.0000	0.0000	0.0000	0.0000	0.0000	0.0000	0.0000	0.0000	0.0000	0.0000	0.0000	0.0000	0.0000	0.0000	0.0000	0.0000
Worker	9.7000e-004	7.5000e-004	8.5100e-003	2.0000e-005	2.4700e-003	2.0000e-005	2.4900e-003	6.5000e-004	2.0000e-005	6.7000e-004	0.0000	2.2251	2.2251	7.0000e-005	0.0000	2.2267
Total	2.9000e-003	0.0641	0.0233	2.0000e-004	6.4100e-003	2.1000e-004	6.6200e-003	1.7300e-003	2.0000e-004	1.9300e-003	0.0000	19.6816	19.6816	1.2800e-003	0.0000	19.7136

3.3 Site Preparation - 2021

Unmitigated Construction On-Site

	ROG	NOx	CO	SO2	Fugitive PM10	Exhaust PM10	PM10 Total	Fugitive PM2.5	Exhaust PM2.5	PM2.5 Total	Bio- CO2	NBio- CO2	Total CO2	CH4	N2O	CO2e
Category	tons/yr										MT/yr					
Fugitive Dust					0.1807	0.0000	0.1807	0.0993	0.0000	0.0993	0.0000	0.0000	0.0000	0.0000	0.0000	0.0000
Off-Road	0.0389	0.4050	0.2115	3.8000e-004		0.0204	0.0204		0.0188	0.0188	0.0000	33.4357	33.4357	0.0108	0.0000	33.7061
Total	0.0389	0.4050	0.2115	3.8000e-004	0.1807	0.0204	0.2011	0.0993	0.0188	0.1181	0.0000	33.4357	33.4357	0.0108	0.0000	33.7061

Village South Specific Plan (Proposed) - Los Angeles-South Coast County, Annual

3.3 Site Preparation - 2021

Unmitigated Construction Off-Site

	ROG	NOx	CO	SO2	Fugitive PM10	Exhaust PM10	PM10 Total	Fugitive PM2.5	Exhaust PM2.5	PM2.5 Total	Bio- CO2	NBio- CO2	Total CO2	CH4	N2O	CO2e
Category	tons/yr										MT/yr					
Hauling	0.0000	0.0000	0.0000	0.0000	0.0000	0.0000	0.0000	0.0000	0.0000	0.0000	0.0000	0.0000	0.0000	0.0000	0.0000	0.0000
Vendor	0.0000	0.0000	0.0000	0.0000	0.0000	0.0000	0.0000	0.0000	0.0000	0.0000	0.0000	0.0000	0.0000	0.0000	0.0000	0.0000
Worker	7.7000e-004	6.0000e-004	6.8100e-003	2.0000e-005	1.9700e-003	2.0000e-005	1.9900e-003	5.2000e-004	1.0000e-005	5.4000e-004	0.0000	1.7801	1.7801	5.0000e-005	0.0000	1.7814
Total	7.7000e-004	6.0000e-004	6.8100e-003	2.0000e-005	1.9700e-003	2.0000e-005	1.9900e-003	5.2000e-004	1.0000e-005	5.4000e-004	0.0000	1.7801	1.7801	5.0000e-005	0.0000	1.7814

Mitigated Construction On-Site

	ROG	NOx	CO	SO2	Fugitive PM10	Exhaust PM10	PM10 Total	Fugitive PM2.5	Exhaust PM2.5	PM2.5 Total	Bio- CO2	NBio- CO2	Total CO2	CH4	N2O	CO2e
Category	tons/yr										MT/yr					
Fugitive Dust					0.1807	0.0000	0.1807	0.0993	0.0000	0.0993	0.0000	0.0000	0.0000	0.0000	0.0000	0.0000
Off-Road	0.0389	0.4050	0.2115	3.8000e-004		0.0204	0.0204		0.0188	0.0188	0.0000	33.4357	33.4357	0.0108	0.0000	33.7060
Total	0.0389	0.4050	0.2115	3.8000e-004	0.1807	0.0204	0.2011	0.0993	0.0188	0.1181	0.0000	33.4357	33.4357	0.0108	0.0000	33.7060

Village South Specific Plan (Proposed) - Los Angeles-South Coast County, Annual

3.3 Site Preparation - 2021

Mitigated Construction Off-Site

	ROG	NOx	CO	SO2	Fugitive PM10	Exhaust PM10	PM10 Total	Fugitive PM2.5	Exhaust PM2.5	PM2.5 Total	Bio- CO2	NBio- CO2	Total CO2	CH4	N2O	CO2e
Category	tons/yr										MT/yr					
Hauling	0.0000	0.0000	0.0000	0.0000	0.0000	0.0000	0.0000	0.0000	0.0000	0.0000	0.0000	0.0000	0.0000	0.0000	0.0000	0.0000
Vendor	0.0000	0.0000	0.0000	0.0000	0.0000	0.0000	0.0000	0.0000	0.0000	0.0000	0.0000	0.0000	0.0000	0.0000	0.0000	0.0000
Worker	7.7000e-004	6.0000e-004	6.8100e-003	2.0000e-005	1.9700e-003	2.0000e-005	1.9900e-003	5.2000e-004	1.0000e-005	5.4000e-004	0.0000	1.7801	1.7801	5.0000e-005	0.0000	1.7814
Total	7.7000e-004	6.0000e-004	6.8100e-003	2.0000e-005	1.9700e-003	2.0000e-005	1.9900e-003	5.2000e-004	1.0000e-005	5.4000e-004	0.0000	1.7801	1.7801	5.0000e-005	0.0000	1.7814

3.4 Grading - 2021

Unmitigated Construction On-Site

	ROG	NOx	CO	SO2	Fugitive PM10	Exhaust PM10	PM10 Total	Fugitive PM2.5	Exhaust PM2.5	PM2.5 Total	Bio- CO2	NBio- CO2	Total CO2	CH4	N2O	CO2e
Category	tons/yr										MT/yr					
Fugitive Dust					0.1741	0.0000	0.1741	0.0693	0.0000	0.0693	0.0000	0.0000	0.0000	0.0000	0.0000	0.0000
Off-Road	0.0796	0.8816	0.5867	1.1800e-003		0.0377	0.0377		0.0347	0.0347	0.0000	103.5405	103.5405	0.0335	0.0000	104.3776
Total	0.0796	0.8816	0.5867	1.1800e-003	0.1741	0.0377	0.2118	0.0693	0.0347	0.1040	0.0000	103.5405	103.5405	0.0335	0.0000	104.3776

Village South Specific Plan (Proposed) - Los Angeles-South Coast County, Annual

3.4 Grading - 2021

Unmitigated Construction Off-Site

	ROG	NOx	CO	SO2	Fugitive PM10	Exhaust PM10	PM10 Total	Fugitive PM2.5	Exhaust PM2.5	PM2.5 Total	Bio- CO2	NBio- CO2	Total CO2	CH4	N2O	CO2e
Category	tons/yr										MT/yr					
Hauling	0.0000	0.0000	0.0000	0.0000	0.0000	0.0000	0.0000	0.0000	0.0000	0.0000	0.0000	0.0000	0.0000	0.0000	0.0000	0.0000
Vendor	0.0000	0.0000	0.0000	0.0000	0.0000	0.0000	0.0000	0.0000	0.0000	0.0000	0.0000	0.0000	0.0000	0.0000	0.0000	0.0000
Worker	1.6400e-003	1.2700e-003	0.0144	4.0000e-005	4.1600e-003	3.0000e-005	4.2000e-003	1.1100e-003	3.0000e-005	1.1400e-003	0.0000	3.7579	3.7579	1.1000e-004	0.0000	3.7607
Total	1.6400e-003	1.2700e-003	0.0144	4.0000e-005	4.1600e-003	3.0000e-005	4.2000e-003	1.1100e-003	3.0000e-005	1.1400e-003	0.0000	3.7579	3.7579	1.1000e-004	0.0000	3.7607

Mitigated Construction On-Site

	ROG	NOx	CO	SO2	Fugitive PM10	Exhaust PM10	PM10 Total	Fugitive PM2.5	Exhaust PM2.5	PM2.5 Total	Bio- CO2	NBio- CO2	Total CO2	CH4	N2O	CO2e
Category	tons/yr										MT/yr					
Fugitive Dust					0.1741	0.0000	0.1741	0.0693	0.0000	0.0693	0.0000	0.0000	0.0000	0.0000	0.0000	0.0000
Off-Road	0.0796	0.8816	0.5867	1.1800e-003		0.0377	0.0377		0.0347	0.0347	0.0000	103.5403	103.5403	0.0335	0.0000	104.3775
Total	0.0796	0.8816	0.5867	1.1800e-003	0.1741	0.0377	0.2118	0.0693	0.0347	0.1040	0.0000	103.5403	103.5403	0.0335	0.0000	104.3775

Village South Specific Plan (Proposed) - Los Angeles-South Coast County, Annual

3.4 Grading - 2021

Mitigated Construction Off-Site

	ROG	NOx	CO	SO2	Fugitive PM10	Exhaust PM10	PM10 Total	Fugitive PM2.5	Exhaust PM2.5	PM2.5 Total	Bio- CO2	NBio- CO2	Total CO2	CH4	N2O	CO2e
Category	tons/yr										MT/yr					
Hauling	0.0000	0.0000	0.0000	0.0000	0.0000	0.0000	0.0000	0.0000	0.0000	0.0000	0.0000	0.0000	0.0000	0.0000	0.0000	0.0000
Vendor	0.0000	0.0000	0.0000	0.0000	0.0000	0.0000	0.0000	0.0000	0.0000	0.0000	0.0000	0.0000	0.0000	0.0000	0.0000	0.0000
Worker	1.6400e-003	1.2700e-003	0.0144	4.0000e-005	4.1600e-003	3.0000e-005	4.2000e-003	1.1100e-003	3.0000e-005	1.1400e-003	0.0000	3.7579	3.7579	1.1000e-004	0.0000	3.7607
Total	1.6400e-003	1.2700e-003	0.0144	4.0000e-005	4.1600e-003	3.0000e-005	4.2000e-003	1.1100e-003	3.0000e-005	1.1400e-003	0.0000	3.7579	3.7579	1.1000e-004	0.0000	3.7607

3.4 Grading - 2022

Unmitigated Construction On-Site

	ROG	NOx	CO	SO2	Fugitive PM10	Exhaust PM10	PM10 Total	Fugitive PM2.5	Exhaust PM2.5	PM2.5 Total	Bio- CO2	NBio- CO2	Total CO2	CH4	N2O	CO2e
Category	tons/yr										MT/yr					
Fugitive Dust					0.0807	0.0000	0.0807	0.0180	0.0000	0.0180	0.0000	0.0000	0.0000	0.0000	0.0000	0.0000
Off-Road	0.0127	0.1360	0.1017	2.2000e-004		5.7200e-003	5.7200e-003		5.2600e-003	5.2600e-003	0.0000	19.0871	19.0871	6.1700e-003	0.0000	19.2414
Total	0.0127	0.1360	0.1017	2.2000e-004	0.0807	5.7200e-003	0.0865	0.0180	5.2600e-003	0.0233	0.0000	19.0871	19.0871	6.1700e-003	0.0000	19.2414

Village South Specific Plan (Proposed) - Los Angeles-South Coast County, Annual

3.4 Grading - 2022

Unmitigated Construction Off-Site

	ROG	NOx	CO	SO2	Fugitive PM10	Exhaust PM10	PM10 Total	Fugitive PM2.5	Exhaust PM2.5	PM2.5 Total	Bio- CO2	NBio- CO2	Total CO2	CH4	N2O	CO2e
Category	tons/yr										MT/yr					
Hauling	0.0000	0.0000	0.0000	0.0000	0.0000	0.0000	0.0000	0.0000	0.0000	0.0000	0.0000	0.0000	0.0000	0.0000	0.0000	0.0000
Vendor	0.0000	0.0000	0.0000	0.0000	0.0000	0.0000	0.0000	0.0000	0.0000	0.0000	0.0000	0.0000	0.0000	0.0000	0.0000	0.0000
Worker	2.8000e-004	2.1000e-004	2.4400e-003	1.0000e-005	7.7000e-004	1.0000e-005	7.7000e-004	2.0000e-004	1.0000e-005	2.1000e-004	0.0000	0.6679	0.6679	2.0000e-005	0.0000	0.6684
Total	2.8000e-004	2.1000e-004	2.4400e-003	1.0000e-005	7.7000e-004	1.0000e-005	7.7000e-004	2.0000e-004	1.0000e-005	2.1000e-004	0.0000	0.6679	0.6679	2.0000e-005	0.0000	0.6684

Mitigated Construction On-Site

	ROG	NOx	CO	SO2	Fugitive PM10	Exhaust PM10	PM10 Total	Fugitive PM2.5	Exhaust PM2.5	PM2.5 Total	Bio- CO2	NBio- CO2	Total CO2	CH4	N2O	CO2e
Category	tons/yr										MT/yr					
Fugitive Dust					0.0807	0.0000	0.0807	0.0180	0.0000	0.0180	0.0000	0.0000	0.0000	0.0000	0.0000	0.0000
Off-Road	0.0127	0.1360	0.1017	2.2000e-004		5.7200e-003	5.7200e-003		5.2600e-003	5.2600e-003	0.0000	19.0871	19.0871	6.1700e-003	0.0000	19.2414
Total	0.0127	0.1360	0.1017	2.2000e-004	0.0807	5.7200e-003	0.0865	0.0180	5.2600e-003	0.0233	0.0000	19.0871	19.0871	6.1700e-003	0.0000	19.2414

Village South Specific Plan (Proposed) - Los Angeles-South Coast County, Annual

3.4 Grading - 2022

Mitigated Construction Off-Site

	ROG	NOx	CO	SO2	Fugitive PM10	Exhaust PM10	PM10 Total	Fugitive PM2.5	Exhaust PM2.5	PM2.5 Total	Bio- CO2	NBio- CO2	Total CO2	CH4	N2O	CO2e
Category	tons/yr										MT/yr					
Hauling	0.0000	0.0000	0.0000	0.0000	0.0000	0.0000	0.0000	0.0000	0.0000	0.0000	0.0000	0.0000	0.0000	0.0000	0.0000	0.0000
Vendor	0.0000	0.0000	0.0000	0.0000	0.0000	0.0000	0.0000	0.0000	0.0000	0.0000	0.0000	0.0000	0.0000	0.0000	0.0000	0.0000
Worker	2.8000e-004	2.1000e-004	2.4400e-003	1.0000e-005	7.7000e-004	1.0000e-005	7.7000e-004	2.0000e-004	1.0000e-005	2.1000e-004	0.0000	0.6679	0.6679	2.0000e-005	0.0000	0.6684
Total	2.8000e-004	2.1000e-004	2.4400e-003	1.0000e-005	7.7000e-004	1.0000e-005	7.7000e-004	2.0000e-004	1.0000e-005	2.1000e-004	0.0000	0.6679	0.6679	2.0000e-005	0.0000	0.6684

3.5 Building Construction - 2022

Unmitigated Construction On-Site

	ROG	NOx	CO	SO2	Fugitive PM10	Exhaust PM10	PM10 Total	Fugitive PM2.5	Exhaust PM2.5	PM2.5 Total	Bio- CO2	NBio- CO2	Total CO2	CH4	N2O	CO2e
Category	tons/yr										MT/yr					
Off-Road	0.2158	1.9754	2.0700	3.4100e-003		0.1023	0.1023		0.0963	0.0963	0.0000	293.1324	293.1324	0.0702	0.0000	294.8881
Total	0.2158	1.9754	2.0700	3.4100e-003		0.1023	0.1023		0.0963	0.0963	0.0000	293.1324	293.1324	0.0702	0.0000	294.8881

Village South Specific Plan (Proposed) - Los Angeles-South Coast County, Annual

3.5 Building Construction - 2022

Unmitigated Construction Off-Site

	ROG	NOx	CO	SO2	Fugitive PM10	Exhaust PM10	PM10 Total	Fugitive PM2.5	Exhaust PM2.5	PM2.5 Total	Bio- CO2	NBio- CO2	Total CO2	CH4	N2O	CO2e
Category	tons/yr										MT/yr					
Hauling	0.0000	0.0000	0.0000	0.0000	0.0000	0.0000	0.0000	0.0000	0.0000	0.0000	0.0000	0.0000	0.0000	0.0000	0.0000	0.0000
Vendor	0.0527	1.6961	0.4580	4.5500e-003	0.1140	3.1800e-003	0.1171	0.0329	3.0400e-003	0.0359	0.0000	441.9835	441.9835	0.0264	0.0000	442.6435
Worker	0.4088	0.3066	3.5305	0.0107	1.1103	8.8700e-003	1.1192	0.2949	8.1700e-003	0.3031	0.0000	966.8117	966.8117	0.0266	0.0000	967.4773
Total	0.4616	2.0027	3.9885	0.0152	1.2243	0.0121	1.2363	0.3278	0.0112	0.3390	0.0000	1,408.7952	1,408.7952	0.0530	0.0000	1,410.1208

Mitigated Construction On-Site

	ROG	NOx	CO	SO2	Fugitive PM10	Exhaust PM10	PM10 Total	Fugitive PM2.5	Exhaust PM2.5	PM2.5 Total	Bio- CO2	NBio- CO2	Total CO2	CH4	N2O	CO2e
Category	tons/yr										MT/yr					
Off-Road	0.2158	1.9754	2.0700	3.4100e-003		0.1023	0.1023		0.0963	0.0963	0.0000	293.1321	293.1321	0.0702	0.0000	294.8877
Total	0.2158	1.9754	2.0700	3.4100e-003		0.1023	0.1023		0.0963	0.0963	0.0000	293.1321	293.1321	0.0702	0.0000	294.8877

Village South Specific Plan (Proposed) - Los Angeles-South Coast County, Annual

3.5 Building Construction - 2022

Mitigated Construction Off-Site

	ROG	NOx	CO	SO2	Fugitive PM10	Exhaust PM10	PM10 Total	Fugitive PM2.5	Exhaust PM2.5	PM2.5 Total	Bio- CO2	NBio- CO2	Total CO2	CH4	N2O	CO2e
Category	tons/yr										MT/yr					
Hauling	0.0000	0.0000	0.0000	0.0000	0.0000	0.0000	0.0000	0.0000	0.0000	0.0000	0.0000	0.0000	0.0000	0.0000	0.0000	0.0000
Vendor	0.0527	1.6961	0.4580	4.5500e-003	0.1140	3.1800e-003	0.1171	0.0329	3.0400e-003	0.0359	0.0000	441.9835	441.9835	0.0264	0.0000	442.6435
Worker	0.4088	0.3066	3.5305	0.0107	1.1103	8.8700e-003	1.1192	0.2949	8.1700e-003	0.3031	0.0000	966.8117	966.8117	0.0266	0.0000	967.4773
Total	0.4616	2.0027	3.9885	0.0152	1.2243	0.0121	1.2363	0.3278	0.0112	0.3390	0.0000	1,408.7952	1,408.7952	0.0530	0.0000	1,410.1208

3.5 Building Construction - 2023

Unmitigated Construction On-Site

	ROG	NOx	CO	SO2	Fugitive PM10	Exhaust PM10	PM10 Total	Fugitive PM2.5	Exhaust PM2.5	PM2.5 Total	Bio- CO2	NBio- CO2	Total CO2	CH4	N2O	CO2e
Category	tons/yr										MT/yr					
Off-Road	0.1942	1.7765	2.0061	3.3300e-003		0.0864	0.0864		0.0813	0.0813	0.0000	286.2789	286.2789	0.0681	0.0000	287.9814
Total	0.1942	1.7765	2.0061	3.3300e-003		0.0864	0.0864		0.0813	0.0813	0.0000	286.2789	286.2789	0.0681	0.0000	287.9814

Village South Specific Plan (Proposed) - Los Angeles-South Coast County, Annual

3.5 Building Construction - 2023

Unmitigated Construction Off-Site

	ROG	NOx	CO	SO2	Fugitive PM10	Exhaust PM10	PM10 Total	Fugitive PM2.5	Exhaust PM2.5	PM2.5 Total	Bio- CO2	NBio- CO2	Total CO2	CH4	N2O	CO2e
Category	tons/yr										MT/yr					
Hauling	0.0000	0.0000	0.0000	0.0000	0.0000	0.0000	0.0000	0.0000	0.0000	0.0000	0.0000	0.0000	0.0000	0.0000	0.0000	0.0000
Vendor	0.0382	1.2511	0.4011	4.3000e-003	0.1113	1.4600e-003	0.1127	0.0321	1.4000e-003	0.0335	0.0000	417.9930	417.9930	0.0228	0.0000	418.5624
Worker	0.3753	0.2708	3.1696	0.0101	1.0840	8.4100e-003	1.0924	0.2879	7.7400e-003	0.2957	0.0000	909.3439	909.3439	0.0234	0.0000	909.9291
Total	0.4135	1.5218	3.5707	0.0144	1.1953	9.8700e-003	1.2051	0.3200	9.1400e-003	0.3292	0.0000	1,327.3369	1,327.3369	0.0462	0.0000	1,328.4916

Mitigated Construction On-Site

	ROG	NOx	CO	SO2	Fugitive PM10	Exhaust PM10	PM10 Total	Fugitive PM2.5	Exhaust PM2.5	PM2.5 Total	Bio- CO2	NBio- CO2	Total CO2	CH4	N2O	CO2e
Category	tons/yr										MT/yr					
Off-Road	0.1942	1.7765	2.0061	3.3300e-003		0.0864	0.0864		0.0813	0.0813	0.0000	286.2785	286.2785	0.0681	0.0000	287.9811
Total	0.1942	1.7765	2.0061	3.3300e-003		0.0864	0.0864		0.0813	0.0813	0.0000	286.2785	286.2785	0.0681	0.0000	287.9811

Village South Specific Plan (Proposed) - Los Angeles-South Coast County, Annual

3.5 Building Construction - 2023

Mitigated Construction Off-Site

	ROG	NOx	CO	SO2	Fugitive PM10	Exhaust PM10	PM10 Total	Fugitive PM2.5	Exhaust PM2.5	PM2.5 Total	Bio- CO2	NBio- CO2	Total CO2	CH4	N2O	CO2e
Category	tons/yr										MT/yr					
Hauling	0.0000	0.0000	0.0000	0.0000	0.0000	0.0000	0.0000	0.0000	0.0000	0.0000	0.0000	0.0000	0.0000	0.0000	0.0000	0.0000
Vendor	0.0382	1.2511	0.4011	4.3000e-003	0.1113	1.4600e-003	0.1127	0.0321	1.4000e-003	0.0335	0.0000	417.9930	417.9930	0.0228	0.0000	418.5624
Worker	0.3753	0.2708	3.1696	0.0101	1.0840	8.4100e-003	1.0924	0.2879	7.7400e-003	0.2957	0.0000	909.3439	909.3439	0.0234	0.0000	909.9291
Total	0.4135	1.5218	3.5707	0.0144	1.1953	9.8700e-003	1.2051	0.3200	9.1400e-003	0.3292	0.0000	1,327.3369	1,327.3369	0.0462	0.0000	1,328.4916

3.6 Paving - 2023

Unmitigated Construction On-Site

	ROG	NOx	CO	SO2	Fugitive PM10	Exhaust PM10	PM10 Total	Fugitive PM2.5	Exhaust PM2.5	PM2.5 Total	Bio- CO2	NBio- CO2	Total CO2	CH4	N2O	CO2e
Category	tons/yr										MT/yr					
Off-Road	6.7100e-003	0.0663	0.0948	1.5000e-004		3.3200e-003	3.3200e-003		3.0500e-003	3.0500e-003	0.0000	13.0175	13.0175	4.2100e-003	0.0000	13.1227
Paving	0.0000					0.0000	0.0000		0.0000	0.0000	0.0000	0.0000	0.0000	0.0000	0.0000	0.0000
Total	6.7100e-003	0.0663	0.0948	1.5000e-004		3.3200e-003	3.3200e-003		3.0500e-003	3.0500e-003	0.0000	13.0175	13.0175	4.2100e-003	0.0000	13.1227

Village South Specific Plan (Proposed) - Los Angeles-South Coast County, Annual

3.6 Paving - 2023

Unmitigated Construction Off-Site

	ROG	NOx	CO	SO2	Fugitive PM10	Exhaust PM10	PM10 Total	Fugitive PM2.5	Exhaust PM2.5	PM2.5 Total	Bio- CO2	NBio- CO2	Total CO2	CH4	N2O	CO2e
Category	tons/yr										MT/yr					
Hauling	0.0000	0.0000	0.0000	0.0000	0.0000	0.0000	0.0000	0.0000	0.0000	0.0000	0.0000	0.0000	0.0000	0.0000	0.0000	0.0000
Vendor	0.0000	0.0000	0.0000	0.0000	0.0000	0.0000	0.0000	0.0000	0.0000	0.0000	0.0000	0.0000	0.0000	0.0000	0.0000	0.0000
Worker	3.7000e-004	2.7000e-004	3.1200e-003	1.0000e-005	1.0700e-003	1.0000e-005	1.0800e-003	2.8000e-004	1.0000e-005	2.9000e-004	0.0000	0.8963	0.8963	2.0000e-005	0.0000	0.8968
Total	3.7000e-004	2.7000e-004	3.1200e-003	1.0000e-005	1.0700e-003	1.0000e-005	1.0800e-003	2.8000e-004	1.0000e-005	2.9000e-004	0.0000	0.8963	0.8963	2.0000e-005	0.0000	0.8968

Mitigated Construction On-Site

	ROG	NOx	CO	SO2	Fugitive PM10	Exhaust PM10	PM10 Total	Fugitive PM2.5	Exhaust PM2.5	PM2.5 Total	Bio- CO2	NBio- CO2	Total CO2	CH4	N2O	CO2e
Category	tons/yr										MT/yr					
Off-Road	6.7100e-003	0.0663	0.0948	1.5000e-004		3.3200e-003	3.3200e-003		3.0500e-003	3.0500e-003	0.0000	13.0175	13.0175	4.2100e-003	0.0000	13.1227
Paving	0.0000					0.0000	0.0000		0.0000	0.0000	0.0000	0.0000	0.0000	0.0000	0.0000	0.0000
Total	6.7100e-003	0.0663	0.0948	1.5000e-004		3.3200e-003	3.3200e-003		3.0500e-003	3.0500e-003	0.0000	13.0175	13.0175	4.2100e-003	0.0000	13.1227

Village South Specific Plan (Proposed) - Los Angeles-South Coast County, Annual

3.6 Paving - 2023

Mitigated Construction Off-Site

	ROG	NOx	CO	SO2	Fugitive PM10	Exhaust PM10	PM10 Total	Fugitive PM2.5	Exhaust PM2.5	PM2.5 Total	Bio- CO2	NBio- CO2	Total CO2	CH4	N2O	CO2e
Category	tons/yr										MT/yr					
Hauling	0.0000	0.0000	0.0000	0.0000	0.0000	0.0000	0.0000	0.0000	0.0000	0.0000	0.0000	0.0000	0.0000	0.0000	0.0000	0.0000
Vendor	0.0000	0.0000	0.0000	0.0000	0.0000	0.0000	0.0000	0.0000	0.0000	0.0000	0.0000	0.0000	0.0000	0.0000	0.0000	0.0000
Worker	3.7000e-004	2.7000e-004	3.1200e-003	1.0000e-005	1.0700e-003	1.0000e-005	1.0800e-003	2.8000e-004	1.0000e-005	2.9000e-004	0.0000	0.8963	0.8963	2.0000e-005	0.0000	0.8968
Total	3.7000e-004	2.7000e-004	3.1200e-003	1.0000e-005	1.0700e-003	1.0000e-005	1.0800e-003	2.8000e-004	1.0000e-005	2.9000e-004	0.0000	0.8963	0.8963	2.0000e-005	0.0000	0.8968

3.6 Paving - 2024

Unmitigated Construction On-Site

	ROG	NOx	CO	SO2	Fugitive PM10	Exhaust PM10	PM10 Total	Fugitive PM2.5	Exhaust PM2.5	PM2.5 Total	Bio- CO2	NBio- CO2	Total CO2	CH4	N2O	CO2e
Category	tons/yr										MT/yr					
Off-Road	0.0109	0.1048	0.1609	2.5000e-004		5.1500e-003	5.1500e-003		4.7400e-003	4.7400e-003	0.0000	22.0292	22.0292	7.1200e-003	0.0000	22.2073
Paving	0.0000					0.0000	0.0000		0.0000	0.0000	0.0000	0.0000	0.0000	0.0000	0.0000	0.0000
Total	0.0109	0.1048	0.1609	2.5000e-004		5.1500e-003	5.1500e-003		4.7400e-003	4.7400e-003	0.0000	22.0292	22.0292	7.1200e-003	0.0000	22.2073

Village South Specific Plan (Proposed) - Los Angeles-South Coast County, Annual

3.6 Paving - 2024

Unmitigated Construction Off-Site

	ROG	NOx	CO	SO2	Fugitive PM10	Exhaust PM10	PM10 Total	Fugitive PM2.5	Exhaust PM2.5	PM2.5 Total	Bio- CO2	NBio- CO2	Total CO2	CH4	N2O	CO2e
Category	tons/yr										MT/yr					
Hauling	0.0000	0.0000	0.0000	0.0000	0.0000	0.0000	0.0000	0.0000	0.0000	0.0000	0.0000	0.0000	0.0000	0.0000	0.0000	0.0000
Vendor	0.0000	0.0000	0.0000	0.0000	0.0000	0.0000	0.0000	0.0000	0.0000	0.0000	0.0000	0.0000	0.0000	0.0000	0.0000	0.0000
Worker	5.9000e-004	4.1000e-004	4.9200e-003	2.0000e-005	1.8100e-003	1.0000e-005	1.8200e-003	4.8000e-004	1.0000e-005	4.9000e-004	0.0000	1.4697	1.4697	4.0000e-005	0.0000	1.4706
Total	5.9000e-004	4.1000e-004	4.9200e-003	2.0000e-005	1.8100e-003	1.0000e-005	1.8200e-003	4.8000e-004	1.0000e-005	4.9000e-004	0.0000	1.4697	1.4697	4.0000e-005	0.0000	1.4706

Mitigated Construction On-Site

	ROG	NOx	CO	SO2	Fugitive PM10	Exhaust PM10	PM10 Total	Fugitive PM2.5	Exhaust PM2.5	PM2.5 Total	Bio- CO2	NBio- CO2	Total CO2	CH4	N2O	CO2e
Category	tons/yr										MT/yr					
Off-Road	0.0109	0.1048	0.1609	2.5000e-004		5.1500e-003	5.1500e-003		4.7400e-003	4.7400e-003	0.0000	22.0292	22.0292	7.1200e-003	0.0000	22.2073
Paving	0.0000					0.0000	0.0000		0.0000	0.0000	0.0000	0.0000	0.0000	0.0000	0.0000	0.0000
Total	0.0109	0.1048	0.1609	2.5000e-004		5.1500e-003	5.1500e-003		4.7400e-003	4.7400e-003	0.0000	22.0292	22.0292	7.1200e-003	0.0000	22.2073

Village South Specific Plan (Proposed) - Los Angeles-South Coast County, Annual

3.6 Paving - 2024

Mitigated Construction Off-Site

	ROG	NOx	CO	SO2	Fugitive PM10	Exhaust PM10	PM10 Total	Fugitive PM2.5	Exhaust PM2.5	PM2.5 Total	Bio- CO2	NBio- CO2	Total CO2	CH4	N2O	CO2e
Category	tons/yr										MT/yr					
Hauling	0.0000	0.0000	0.0000	0.0000	0.0000	0.0000	0.0000	0.0000	0.0000	0.0000	0.0000	0.0000	0.0000	0.0000	0.0000	0.0000
Vendor	0.0000	0.0000	0.0000	0.0000	0.0000	0.0000	0.0000	0.0000	0.0000	0.0000	0.0000	0.0000	0.0000	0.0000	0.0000	0.0000
Worker	5.9000e-004	4.1000e-004	4.9200e-003	2.0000e-005	1.8100e-003	1.0000e-005	1.8200e-003	4.8000e-004	1.0000e-005	4.9000e-004	0.0000	1.4697	1.4697	4.0000e-005	0.0000	1.4706
Total	5.9000e-004	4.1000e-004	4.9200e-003	2.0000e-005	1.8100e-003	1.0000e-005	1.8200e-003	4.8000e-004	1.0000e-005	4.9000e-004	0.0000	1.4697	1.4697	4.0000e-005	0.0000	1.4706

3.7 Architectural Coating - 2024

Unmitigated Construction On-Site

	ROG	NOx	CO	SO2	Fugitive PM10	Exhaust PM10	PM10 Total	Fugitive PM2.5	Exhaust PM2.5	PM2.5 Total	Bio- CO2	NBio- CO2	Total CO2	CH4	N2O	CO2e
Category	tons/yr										MT/yr					
Archit. Coating	4.1372					0.0000	0.0000		0.0000	0.0000	0.0000	0.0000	0.0000	0.0000	0.0000	0.0000
Off-Road	3.1600e-003	0.0213	0.0317	5.0000e-005		1.0700e-003	1.0700e-003		1.0700e-003	1.0700e-003	0.0000	4.4682	4.4682	2.5000e-004	0.0000	4.4745
Total	4.1404	0.0213	0.0317	5.0000e-005		1.0700e-003	1.0700e-003		1.0700e-003	1.0700e-003	0.0000	4.4682	4.4682	2.5000e-004	0.0000	4.4745

Village South Specific Plan (Proposed) - Los Angeles-South Coast County, Annual

3.7 Architectural Coating - 2024

Unmitigated Construction Off-Site

	ROG	NOx	CO	SO2	Fugitive PM10	Exhaust PM10	PM10 Total	Fugitive PM2.5	Exhaust PM2.5	PM2.5 Total	Bio- CO2	NBio- CO2	Total CO2	CH4	N2O	CO2e
Category	tons/yr										MT/yr					
Hauling	0.0000	0.0000	0.0000	0.0000	0.0000	0.0000	0.0000	0.0000	0.0000	0.0000	0.0000	0.0000	0.0000	0.0000	0.0000	0.0000
Vendor	0.0000	0.0000	0.0000	0.0000	0.0000	0.0000	0.0000	0.0000	0.0000	0.0000	0.0000	0.0000	0.0000	0.0000	0.0000	0.0000
Worker	0.0101	6.9900e-003	0.0835	2.8000e-004	0.0307	2.3000e-004	0.0309	8.1500e-003	2.2000e-004	8.3700e-003	0.0000	24.9407	24.9407	6.1000e-004	0.0000	24.9558
Total	0.0101	6.9900e-003	0.0835	2.8000e-004	0.0307	2.3000e-004	0.0309	8.1500e-003	2.2000e-004	8.3700e-003	0.0000	24.9407	24.9407	6.1000e-004	0.0000	24.9558

Mitigated Construction On-Site

	ROG	NOx	CO	SO2	Fugitive PM10	Exhaust PM10	PM10 Total	Fugitive PM2.5	Exhaust PM2.5	PM2.5 Total	Bio- CO2	NBio- CO2	Total CO2	CH4	N2O	CO2e
Category	tons/yr										MT/yr					
Archit. Coating	4.1372					0.0000	0.0000		0.0000	0.0000	0.0000	0.0000	0.0000	0.0000	0.0000	0.0000
Off-Road	3.1600e-003	0.0213	0.0317	5.0000e-005		1.0700e-003	1.0700e-003		1.0700e-003	1.0700e-003	0.0000	4.4682	4.4682	2.5000e-004	0.0000	4.4745
Total	4.1404	0.0213	0.0317	5.0000e-005		1.0700e-003	1.0700e-003		1.0700e-003	1.0700e-003	0.0000	4.4682	4.4682	2.5000e-004	0.0000	4.4745

Village South Specific Plan (Proposed) - Los Angeles-South Coast County, Annual

3.7 Architectural Coating - 2024

Mitigated Construction Off-Site

	ROG	NOx	CO	SO2	Fugitive PM10	Exhaust PM10	PM10 Total	Fugitive PM2.5	Exhaust PM2.5	PM2.5 Total	Bio- CO2	NBio- CO2	Total CO2	CH4	N2O	CO2e
Category	tons/yr										MT/yr					
Hauling	0.0000	0.0000	0.0000	0.0000	0.0000	0.0000	0.0000	0.0000	0.0000	0.0000	0.0000	0.0000	0.0000	0.0000	0.0000	0.0000
Vendor	0.0000	0.0000	0.0000	0.0000	0.0000	0.0000	0.0000	0.0000	0.0000	0.0000	0.0000	0.0000	0.0000	0.0000	0.0000	0.0000
Worker	0.0101	6.9900e-003	0.0835	2.8000e-004	0.0307	2.3000e-004	0.0309	8.1500e-003	2.2000e-004	8.3700e-003	0.0000	24.9407	24.9407	6.1000e-004	0.0000	24.9558
Total	0.0101	6.9900e-003	0.0835	2.8000e-004	0.0307	2.3000e-004	0.0309	8.1500e-003	2.2000e-004	8.3700e-003	0.0000	24.9407	24.9407	6.1000e-004	0.0000	24.9558

4.0 Operational Detail - Mobile

4.1 Mitigation Measures Mobile

Village South Specific Plan (Proposed) - Los Angeles-South Coast County, Annual

	ROG	NOx	CO	SO2	Fugitive PM10	Exhaust PM10	PM10 Total	Fugitive PM2.5	Exhaust PM2.5	PM2.5 Total	Bio- CO2	NBio- CO2	Total CO2	CH4	N2O	CO2e
Category	tons/yr										MT/yr					
Mitigated	1.5857	7.9962	19.1834	0.0821	7.7979	0.0580	7.8559	2.0895	0.0539	2.1434	0.0000	7,620.4986	7,620.4986	0.3407	0.0000	7,629.0162
Unmitigated	1.5857	7.9962	19.1834	0.0821	7.7979	0.0580	7.8559	2.0895	0.0539	2.1434	0.0000	7,620.4986	7,620.4986	0.3407	0.0000	7,629.0162

4.2 Trip Summary Information

Land Use	Average Daily Trip Rate			Unmitigated	Mitigated
	Weekday	Saturday	Sunday	Annual VMT	Annual VMT
Apartments Low Rise	145.75	154.25	154.00	506,227	506,227
Apartments Mid Rise	4,026.75	3,773.25	4075.50	13,660,065	13,660,065
General Office Building	288.45	62.55	31.05	706,812	706,812
High Turnover (Sit Down Restaurant)	2,368.80	2,873.52	2817.72	3,413,937	3,413,937
Hotel	192.00	187.50	160.00	445,703	445,703
Quality Restaurant	501.12	511.92	461.20	707,488	707,488
Regional Shopping Center	528.08	601.44	357.84	1,112,221	1,112,221
Total	8,050.95	8,164.43	8,057.31	20,552,452	20,552,452

4.3 Trip Type Information

Village South Specific Plan (Proposed) - Los Angeles-South Coast County, Annual

Land Use	Miles			Trip %			Trip Purpose %		
	H-W or C-W	H-S or C-C	H-O or C-NW	H-W or C-W	H-S or C-C	H-O or C-NW	Primary	Diverted	Pass-by
Apartments Low Rise	14.70	5.90	8.70	40.20	19.20	40.60	86	11	3
Apartments Mid Rise	14.70	5.90	8.70	40.20	19.20	40.60	86	11	3
General Office Building	16.60	8.40	6.90	33.00	48.00	19.00	77	19	4
High Turnover (Sit Down Restaurant)	16.60	8.40	6.90	8.50	72.50	19.00	37	20	43
Hotel	16.60	8.40	6.90	19.40	61.60	19.00	58	38	4
Quality Restaurant	16.60	8.40	6.90	12.00	69.00	19.00	38	18	44
Regional Shopping Center	16.60	8.40	6.90	16.30	64.70	19.00	54	35	11

4.4 Fleet Mix

Land Use	LDA	LDT1	LDT2	MDV	LHD1	LHD2	MHD	HHD	OBUS	UBUS	MCY	SBUS	MH
Apartments Low Rise	0.543088	0.044216	0.209971	0.116369	0.014033	0.006332	0.021166	0.033577	0.002613	0.001817	0.005285	0.000712	0.000821
Apartments Mid Rise	0.543088	0.044216	0.209971	0.116369	0.014033	0.006332	0.021166	0.033577	0.002613	0.001817	0.005285	0.000712	0.000821
General Office Building	0.543088	0.044216	0.209971	0.116369	0.014033	0.006332	0.021166	0.033577	0.002613	0.001817	0.005285	0.000712	0.000821
High Turnover (Sit Down Restaurant)	0.543088	0.044216	0.209971	0.116369	0.014033	0.006332	0.021166	0.033577	0.002613	0.001817	0.005285	0.000712	0.000821
Hotel	0.543088	0.044216	0.209971	0.116369	0.014033	0.006332	0.021166	0.033577	0.002613	0.001817	0.005285	0.000712	0.000821
Quality Restaurant	0.543088	0.044216	0.209971	0.116369	0.014033	0.006332	0.021166	0.033577	0.002613	0.001817	0.005285	0.000712	0.000821
Regional Shopping Center	0.543088	0.044216	0.209971	0.116369	0.014033	0.006332	0.021166	0.033577	0.002613	0.001817	0.005285	0.000712	0.000821

5.0 Energy Detail

Historical Energy Use: N

5.1 Mitigation Measures Energy

Village South Specific Plan (Proposed) - Los Angeles-South Coast County, Annual

	ROG	NOx	CO	SO2	Fugitive PM10	Exhaust PM10	PM10 Total	Fugitive PM2.5	Exhaust PM2.5	PM2.5 Total	Bio- CO2	NBio- CO2	Total CO2	CH4	N2O	CO2e
Category	tons/yr										MT/yr					
Electricity Mitigated							0.0000	0.0000		0.0000	0.0000	2,512.6465	2,512.6465	0.1037	0.0215	2,521.6356
Electricity Unmitigated							0.0000	0.0000		0.0000	0.0000	2,512.6465	2,512.6465	0.1037	0.0215	2,521.6356
NaturalGas Mitigated	0.1398	1.2312	0.7770	7.6200e-003			0.0966	0.0966		0.0966	0.0966	1,383.4267	1,383.4267	0.0265	0.0254	1,391.6478
NaturalGas Unmitigated	0.1398	1.2312	0.7770	7.6200e-003			0.0966	0.0966		0.0966	0.0966	1,383.4267	1,383.4267	0.0265	0.0254	1,391.6478

Village South Specific Plan (Proposed) - Los Angeles-South Coast County, Annual

5.2 Energy by Land Use - NaturalGas

Unmitigated

	NaturalGas Use	ROG	NOx	CO	SO2	Fugitive PM10	Exhaust PM10	PM10 Total	Fugitive PM2.5	Exhaust PM2.5	PM2.5 Total	Bio- CO2	NBio- CO2	Total CO2	CH4	N2O	CO2e
Land Use	kBTU/yr	tons/yr										MT/yr					
Apartments Low Rise	408494	2.2000e-003	0.0188	8.0100e-003	1.2000e-004		1.5200e-003	1.5200e-003		1.5200e-003	1.5200e-003	0.0000	21.7988	21.7988	4.2000e-004	4.0000e-004	21.9284
Apartments Mid Rise	1.30613e+007	0.0704	0.6018	0.2561	3.8400e-003		0.0487	0.0487		0.0487	0.0487	0.0000	696.9989	696.9989	0.0134	0.0128	701.1408
General Office Building	468450	2.5300e-003	0.0230	0.0193	1.4000e-004		1.7500e-003	1.7500e-003		1.7500e-003	1.7500e-003	0.0000	24.9983	24.9983	4.8000e-004	4.6000e-004	25.1468
High Turnover (Sit Down Restaurant)	8.30736e+006	0.0448	0.4072	0.3421	2.4400e-003		0.0310	0.0310		0.0310	0.0310	0.0000	443.3124	443.3124	8.5000e-003	8.1300e-003	445.9468
Hotel	1.74095e+006	9.3900e-003	0.0853	0.0717	5.1000e-004		6.4900e-003	6.4900e-003		6.4900e-003	6.4900e-003	0.0000	92.9036	92.9036	1.7800e-003	1.7000e-003	93.4557
Quality Restaurant	1.84608e+006	9.9500e-003	0.0905	0.0760	5.4000e-004		6.8800e-003	6.8800e-003		6.8800e-003	6.8800e-003	0.0000	98.5139	98.5139	1.8900e-003	1.8100e-003	99.0993
Regional Shopping Center	91840	5.0000e-004	4.5000e-003	3.7800e-003	3.0000e-005		3.4000e-004	3.4000e-004		3.4000e-004	3.4000e-004	0.0000	4.9009	4.9009	9.0000e-005	9.0000e-005	4.9301
Total		0.1398	1.2312	0.7770	7.6200e-003		0.0966	0.0966		0.0966	0.0966	0.0000	1,383.4268	1,383.4268	0.0265	0.0254	1,391.6478

Village South Specific Plan (Proposed) - Los Angeles-South Coast County, Annual

5.2 Energy by Land Use - NaturalGas

Mitigated

	NaturalGas Use	ROG	NOx	CO	SO2	Fugitive PM10	Exhaust PM10	PM10 Total	Fugitive PM2.5	Exhaust PM2.5	PM2.5 Total	Bio- CO2	NBio- CO2	Total CO2	CH4	N2O	CO2e
Land Use	kBTU/yr	tons/yr										MT/yr					
Apartments Low Rise	408494	2.2000e-003	0.0188	8.0100e-003	1.2000e-004		1.5200e-003	1.5200e-003		1.5200e-003	1.5200e-003	0.0000	21.7988	21.7988	4.2000e-004	4.0000e-004	21.9284
Apartments Mid Rise	1.30613e+007	0.0704	0.6018	0.2561	3.8400e-003		0.0487	0.0487		0.0487	0.0487	0.0000	696.9989	696.9989	0.0134	0.0128	701.1408
General Office Building	468450	2.5300e-003	0.0230	0.0193	1.4000e-004		1.7500e-003	1.7500e-003		1.7500e-003	1.7500e-003	0.0000	24.9983	24.9983	4.8000e-004	4.6000e-004	25.1468
High Turnover (Sit Down Restaurant)	8.30736e+006	0.0448	0.4072	0.3421	2.4400e-003		0.0310	0.0310		0.0310	0.0310	0.0000	443.3124	443.3124	8.5000e-003	8.1300e-003	445.9468
Hotel	1.74095e+006	9.3900e-003	0.0853	0.0717	5.1000e-004		6.4900e-003	6.4900e-003		6.4900e-003	6.4900e-003	0.0000	92.9036	92.9036	1.7800e-003	1.7000e-003	93.4557
Quality Restaurant	1.84608e+006	9.9500e-003	0.0905	0.0760	5.4000e-004		6.8800e-003	6.8800e-003		6.8800e-003	6.8800e-003	0.0000	98.5139	98.5139	1.8900e-003	1.8100e-003	99.0993
Regional Shopping Center	91840	5.0000e-004	4.5000e-003	3.7800e-003	3.0000e-005		3.4000e-004	3.4000e-004		3.4000e-004	3.4000e-004	0.0000	4.9009	4.9009	9.0000e-005	9.0000e-005	4.9301
Total		0.1398	1.2312	0.7770	7.6200e-003		0.0966	0.0966		0.0966	0.0966	0.0000	1,383.4268	1,383.4268	0.0265	0.0254	1,391.6478

Village South Specific Plan (Proposed) - Los Angeles-South Coast County, Annual

5.3 Energy by Land Use - Electricity

Unmitigated

	Electricity Use	Total CO2	CH4	N2O	CO2e
Land Use	kWh/yr	MT/yr			
Apartments Low Rise	106010	33.7770	1.3900e-003	2.9000e-004	33.8978
Apartments Mid Rise	3.94697e+006	1,257.5879	0.0519	0.0107	1,262.0869
General Office Building	584550	186.2502	7.6900e-003	1.5900e-003	186.9165
High Turnover (Sit Down Restaurant)	1.58904e+006	506.3022	0.0209	4.3200e-003	508.1135
Hotel	550308	175.3399	7.2400e-003	1.5000e-003	175.9672
Quality Restaurant	353120	112.5116	4.6500e-003	9.6000e-004	112.9141
Regional Shopping Center	756000	240.8778	9.9400e-003	2.0600e-003	241.7395
Total		2,512.6465	0.1037	0.0215	2,521.6356

Village South Specific Plan (Proposed) - Los Angeles-South Coast County, Annual

5.3 Energy by Land Use - Electricity

Mitigated

	Electricity Use	Total CO2	CH4	N2O	CO2e
Land Use	kWh/yr	MT/yr			
Apartments Low Rise	106010	33.7770	1.3900e-003	2.9000e-004	33.8978
Apartments Mid Rise	3.94697e+006	1,257.5879	0.0519	0.0107	1,262.0869
General Office Building	584550	186.2502	7.6900e-003	1.5900e-003	186.9165
High Turnover (Sit Down Restaurant)	1.58904e+006	506.3022	0.0209	4.3200e-003	508.1135
Hotel	550308	175.3399	7.2400e-003	1.5000e-003	175.9672
Quality Restaurant	353120	112.5116	4.6500e-003	9.6000e-004	112.9141
Regional Shopping Center	756000	240.8778	9.9400e-003	2.0600e-003	241.7395
Total		2,512.6465	0.1037	0.0215	2,521.6356

6.0 Area Detail

6.1 Mitigation Measures Area

Village South Specific Plan (Proposed) - Los Angeles-South Coast County, Annual

	ROG	NOx	CO	SO2	Fugitive PM10	Exhaust PM10	PM10 Total	Fugitive PM2.5	Exhaust PM2.5	PM2.5 Total	Bio- CO2	NBio- CO2	Total CO2	CH4	N2O	CO2e
Category	tons/yr										MT/yr					
Mitigated	5.1437	0.2950	10.3804	1.6700e-003		0.0714	0.0714		0.0714	0.0714	0.0000	220.9670	220.9670	0.0201	3.7400e-003	222.5835
Unmitigated	5.1437	0.2950	10.3804	1.6700e-003		0.0714	0.0714		0.0714	0.0714	0.0000	220.9670	220.9670	0.0201	3.7400e-003	222.5835

6.2 Area by SubCategory

Unmitigated

	ROG	NOx	CO	SO2	Fugitive PM10	Exhaust PM10	PM10 Total	Fugitive PM2.5	Exhaust PM2.5	PM2.5 Total	Bio- CO2	NBio- CO2	Total CO2	CH4	N2O	CO2e
SubCategory	tons/yr										MT/yr					
Architectural Coating	0.4137					0.0000	0.0000		0.0000	0.0000	0.0000	0.0000	0.0000	0.0000	0.0000	0.0000
Consumer Products	4.3998					0.0000	0.0000		0.0000	0.0000	0.0000	0.0000	0.0000	0.0000	0.0000	0.0000
Hearth	0.0206	0.1763	0.0750	1.1200e-003		0.0143	0.0143		0.0143	0.0143	0.0000	204.1166	204.1166	3.9100e-003	3.7400e-003	205.3295
Landscaping	0.3096	0.1187	10.3054	5.4000e-004		0.0572	0.0572		0.0572	0.0572	0.0000	16.8504	16.8504	0.0161	0.0000	17.2540
Total	5.1437	0.2950	10.3804	1.6600e-003		0.0714	0.0714		0.0714	0.0714	0.0000	220.9670	220.9670	0.0201	3.7400e-003	222.5835

Village South Specific Plan (Proposed) - Los Angeles-South Coast County, Annual

6.2 Area by SubCategory

Mitigated

	ROG	NOx	CO	SO2	Fugitive PM10	Exhaust PM10	PM10 Total	Fugitive PM2.5	Exhaust PM2.5	PM2.5 Total	Bio- CO2	NBio- CO2	Total CO2	CH4	N2O	CO2e
SubCategory	tons/yr										MT/yr					
Architectural Coating	0.4137					0.0000	0.0000		0.0000	0.0000	0.0000	0.0000	0.0000	0.0000	0.0000	0.0000
Consumer Products	4.3998					0.0000	0.0000		0.0000	0.0000	0.0000	0.0000	0.0000	0.0000	0.0000	0.0000
Hearth	0.0206	0.1763	0.0750	1.1200e-003		0.0143	0.0143		0.0143	0.0143	0.0000	204.1166	204.1166	3.9100e-003	3.7400e-003	205.3295
Landscaping	0.3096	0.1187	10.3054	5.4000e-004		0.0572	0.0572		0.0572	0.0572	0.0000	16.8504	16.8504	0.0161	0.0000	17.2540
Total	5.1437	0.2950	10.3804	1.6600e-003		0.0714	0.0714		0.0714	0.0714	0.0000	220.9670	220.9670	0.0201	3.7400e-003	222.5835

7.0 Water Detail

7.1 Mitigation Measures Water

Village South Specific Plan (Proposed) - Los Angeles-South Coast County, Annual

	Total CO2	CH4	N2O	CO2e
Category	MT/yr			
Mitigated	585.8052	3.0183	0.0755	683.7567
Unmitigated	585.8052	3.0183	0.0755	683.7567

Village South Specific Plan (Proposed) - Los Angeles-South Coast County, Annual

7.2 Water by Land Use

Unmitigated

	Indoor/Outdoor Use	Total CO2	CH4	N2O	CO2e
Land Use	Mgal	MT/yr			
Apartments Low Rise	1.62885 / 1.02688	10.9095	0.0535	1.3400e-003	12.6471
Apartments Mid Rise	63.5252 / 40.0485	425.4719	2.0867	0.0523	493.2363
General Office Building	7.99802 / 4.90201	53.0719	0.2627	6.5900e-003	61.6019
High Turnover (Sit Down Restaurant)	10.9272 / 0.697482	51.2702	0.3580	8.8200e-003	62.8482
Hotel	1.26834 / 0.140927	6.1633	0.0416	1.0300e-003	7.5079
Quality Restaurant	2.42827 / 0.154996	11.3934	0.0796	1.9600e-003	13.9663
Regional Shopping Center	4.14806 / 2.54236	27.5250	0.1363	3.4200e-003	31.9490
Total		585.8052	3.0183	0.0755	683.7567

Village South Specific Plan (Proposed) - Los Angeles-South Coast County, Annual

7.2 Water by Land Use

Mitigated

	Indoor/Outdoor Use	Total CO2	CH4	N2O	CO2e
Land Use	Mgal	MT/yr			
Apartments Low Rise	1.62885 / 1.02688	10.9095	0.0535	1.3400e-003	12.6471
Apartments Mid Rise	63.5252 / 40.0485	425.4719	2.0867	0.0523	493.2363
General Office Building	7.99802 / 4.90201	53.0719	0.2627	6.5900e-003	61.6019
High Turnover (Sit Down Restaurant)	10.9272 / 0.697482	51.2702	0.3580	8.8200e-003	62.8482
Hotel	1.26834 / 0.140927	6.1633	0.0416	1.0300e-003	7.5079
Quality Restaurant	2.42827 / 0.154996	11.3934	0.0796	1.9600e-003	13.9663
Regional Shopping Center	4.14806 / 2.54236	27.5250	0.1363	3.4200e-003	31.9490
Total		585.8052	3.0183	0.0755	683.7567

8.0 Waste Detail

8.1 Mitigation Measures Waste

Village South Specific Plan (Proposed) - Los Angeles-South Coast County, Annual

Category/Year

	Total CO2	CH4	N2O	CO2e
	MT/yr			
Mitigated	207.8079	12.2811	0.0000	514.8354
Unmitigated	207.8079	12.2811	0.0000	514.8354

Village South Specific Plan (Proposed) - Los Angeles-South Coast County, Annual

8.2 Waste by Land Use

Unmitigated

	Waste Disposed	Total CO2	CH4	N2O	CO2e
Land Use	tons	MT/yr			
Apartments Low Rise	11.5	2.3344	0.1380	0.0000	5.7834
Apartments Mid Rise	448.5	91.0415	5.3804	0.0000	225.5513
General Office Building	41.85	8.4952	0.5021	0.0000	21.0464
High Turnover (Sit Down Restaurant)	428.4	86.9613	5.1393	0.0000	215.4430
Hotel	27.38	5.5579	0.3285	0.0000	13.7694
Quality Restaurant	7.3	1.4818	0.0876	0.0000	3.6712
Regional Shopping Center	58.8	11.9359	0.7054	0.0000	29.5706
Total		207.8079	12.2811	0.0000	514.8354

Village South Specific Plan (Proposed) - Los Angeles-South Coast County, Annual

8.2 Waste by Land Use

Mitigated

	Waste Disposed	Total CO2	CH4	N2O	CO2e
Land Use	tons	MT/yr			
Apartments Low Rise	11.5	2.3344	0.1380	0.0000	5.7834
Apartments Mid Rise	448.5	91.0415	5.3804	0.0000	225.5513
General Office Building	41.85	8.4952	0.5021	0.0000	21.0464
High Turnover (Sit Down Restaurant)	428.4	86.9613	5.1393	0.0000	215.4430
Hotel	27.38	5.5579	0.3285	0.0000	13.7694
Quality Restaurant	7.3	1.4818	0.0876	0.0000	3.6712
Regional Shopping Center	58.8	11.9359	0.7054	0.0000	29.5706
Total		207.8079	12.2811	0.0000	514.8354

9.0 Operational Offroad

Equipment Type	Number	Hours/Day	Days/Year	Horse Power	Load Factor	Fuel Type
----------------	--------	-----------	-----------	-------------	-------------	-----------

10.0 Stationary Equipment

Fire Pumps and Emergency Generators

Equipment Type	Number	Hours/Day	Hours/Year	Horse Power	Load Factor	Fuel Type
----------------	--------	-----------	------------	-------------	-------------	-----------

Village South Specific Plan (Proposed) - Los Angeles-South Coast County, Annual

Boilers

Equipment Type	Number	Heat Input/Day	Heat Input/Year	Boiler Rating	Fuel Type
----------------	--------	----------------	-----------------	---------------	-----------

User Defined Equipment

Equipment Type	Number
----------------	--------

11.0 Vegetation

Village South Specific Plan (Proposed) - Los Angeles-South Coast County, Summer

Village South Specific Plan (Proposed)
Los Angeles-South Coast County, Summer

1.0 Project Characteristics

1.1 Land Usage

Land Uses	Size	Metric	Lot Acreage	Floor Surface Area	Population
General Office Building	45.00	1000sqft	1.03	45,000.00	0
High Turnover (Sit Down Restaurant)	36.00	1000sqft	0.83	36,000.00	0
Hotel	50.00	Room	1.67	72,600.00	0
Quality Restaurant	8.00	1000sqft	0.18	8,000.00	0
Apartments Low Rise	25.00	Dwelling Unit	1.56	25,000.00	72
Apartments Mid Rise	975.00	Dwelling Unit	25.66	975,000.00	2789
Regional Shopping Center	56.00	1000sqft	1.29	56,000.00	0

1.2 Other Project Characteristics

Urbanization	Urban	Wind Speed (m/s)	2.2	Precipitation Freq (Days)	33
Climate Zone	9			Operational Year	2028
Utility Company	Southern California Edison				
CO2 Intensity (lb/MW hr)	702.44	CH4 Intensity (lb/MW hr)	0.029	N2O Intensity (lb/MW hr)	0.006

1.3 User Entered Comments & Non-Default Data

Village South Specific Plan (Proposed) - Los Angeles-South Coast County, Summer

Project Characteristics - Consistent with the DEIR's model.

Land Use - See SWAPE comment regarding residential and retail land uses.

Construction Phase - See SWAPE comment regarding individual construction phase lengths.

Demolition - Consistent with the DEIR's model. See SWAPE comment regarding demolition.

Vehicle Trips - Saturday trips consistent with the DEIR's model. See SWAPE comment regarding weekday and Sunday trips.

Woodstoves - Woodstoves and wood-burning fireplaces consistent with the DEIR's model. See SWAPE comment regarding gas fireplaces.

Energy Use -

Construction Off-road Equipment Mitigation - See SWAPE comment on construction-related mitigation.

Area Mitigation - See SWAPE comment regarding operational mitigation measures.

Water Mitigation - See SWAPE comment regarding operational mitigation measures.

Table Name	Column Name	Default Value	New Value
tblFireplaces	FireplaceWoodMass	1,019.20	0.00
tblFireplaces	FireplaceWoodMass	1,019.20	0.00
tblFireplaces	NumberWood	1.25	0.00
tblFireplaces	NumberWood	48.75	0.00
tblVehicleTrips	ST_TR	7.16	6.17
tblVehicleTrips	ST_TR	6.39	3.87
tblVehicleTrips	ST_TR	2.46	1.39
tblVehicleTrips	ST_TR	158.37	79.82
tblVehicleTrips	ST_TR	8.19	3.75
tblVehicleTrips	ST_TR	94.36	63.99
tblVehicleTrips	ST_TR	49.97	10.74
tblVehicleTrips	SU_TR	6.07	6.16
tblVehicleTrips	SU_TR	5.86	4.18
tblVehicleTrips	SU_TR	1.05	0.69
tblVehicleTrips	SU_TR	131.84	78.27

Village South Specific Plan (Proposed) - Los Angeles-South Coast County, Summer

tblVehicleTrips	SU_TR	5.95	3.20
tblVehicleTrips	SU_TR	72.16	57.65
tblVehicleTrips	SU_TR	25.24	6.39
tblVehicleTrips	WD_TR	6.59	5.83
tblVehicleTrips	WD_TR	6.65	4.13
tblVehicleTrips	WD_TR	11.03	6.41
tblVehicleTrips	WD_TR	127.15	65.80
tblVehicleTrips	WD_TR	8.17	3.84
tblVehicleTrips	WD_TR	89.95	62.64
tblVehicleTrips	WD_TR	42.70	9.43
tblWoodstoves	NumberCatalytic	1.25	0.00
tblWoodstoves	NumberCatalytic	48.75	0.00
tblWoodstoves	NumberNoncatalytic	1.25	0.00
tblWoodstoves	NumberNoncatalytic	48.75	0.00
tblWoodstoves	WoodstoveDayYear	25.00	0.00
tblWoodstoves	WoodstoveDayYear	25.00	0.00
tblWoodstoves	WoodstoveWoodMass	999.60	0.00
tblWoodstoves	WoodstoveWoodMass	999.60	0.00

2.0 Emissions Summary

Village South Specific Plan (Proposed) - Los Angeles-South Coast County, Summer

2.1 Overall Construction (Maximum Daily Emission)

Unmitigated Construction

	ROG	NOx	CO	SO2	Fugitive PM10	Exhaust PM10	PM10 Total	Fugitive PM2.5	Exhaust PM2.5	PM2.5 Total	Bio- CO2	NBio- CO2	Total CO2	CH4	N2O	CO2e
Year	lb/day										lb/day					
2021	4.2769	46.4588	31.6840	0.0643	18.2675	2.0461	20.3135	9.9840	1.8824	11.8664	0.0000	6,234.7974	6,234.7974	1.9495	0.0000	6,283.5352
2022	5.3304	38.8967	49.5629	0.1517	9.8688	1.6366	10.7727	3.6558	1.5057	5.1615	0.0000	15,251.5674	15,251.5674	1.9503	0.0000	15,278.5288
2023	4.8957	26.3317	46.7567	0.1472	9.8688	0.7794	10.6482	2.6381	0.7322	3.3702	0.0000	14,807.5269	14,807.5269	1.0250	0.0000	14,833.1521
2024	237.1630	9.5575	15.1043	0.0244	1.7884	0.4698	1.8628	0.4743	0.4322	0.5476	0.0000	2,361.3989	2,361.3989	0.7177	0.0000	2,379.3421
Maximum	237.1630	46.4588	49.5629	0.1517	18.2675	2.0461	20.3135	9.9840	1.8824	11.8664	0.0000	15,251.5674	15,251.5674	1.9503	0.0000	15,278.5288

Village South Specific Plan (Proposed) - Los Angeles-South Coast County, Summer

2.2 Overall Operational

Unmitigated Operational

	ROG	NOx	CO	SO2	Fugitive PM10	Exhaust PM10	PM10 Total	Fugitive PM2.5	Exhaust PM2.5	PM2.5 Total	Bio- CO2	NBio- CO2	Total CO2	CH4	N2O	CO2e
Category	lb/day										lb/day					
Area	30.5020	15.0496	88.4430	0.0944		1.5974	1.5974		1.5974	1.5974	0.0000	18,148.59 50	18,148.59 50	0.4874	0.3300	18,259.11 92
Energy	0.7660	6.7462	4.2573	0.0418		0.5292	0.5292		0.5292	0.5292		8,355.983 2	8,355.983 2	0.1602	0.1532	8,405.638 7
Mobile	9.8489	45.4304	114.8495	0.4917	45.9592	0.3360	46.2951	12.2950	0.3119	12.6070		50,306.60 34	50,306.60 34	2.1807		50,361.12 08
Total	41.1168	67.2262	207.5497	0.6278	45.9592	2.4626	48.4217	12.2950	2.4385	14.7336	0.0000	76,811.18 16	76,811.18 16	2.8282	0.4832	77,025.87 86

Mitigated Operational

	ROG	NOx	CO	SO2	Fugitive PM10	Exhaust PM10	PM10 Total	Fugitive PM2.5	Exhaust PM2.5	PM2.5 Total	Bio- CO2	NBio- CO2	Total CO2	CH4	N2O	CO2e
Category	lb/day										lb/day					
Area	30.5020	15.0496	88.4430	0.0944		1.5974	1.5974		1.5974	1.5974	0.0000	18,148.59 50	18,148.59 50	0.4874	0.3300	18,259.11 92
Energy	0.7660	6.7462	4.2573	0.0418		0.5292	0.5292		0.5292	0.5292		8,355.983 2	8,355.983 2	0.1602	0.1532	8,405.638 7
Mobile	9.8489	45.4304	114.8495	0.4917	45.9592	0.3360	46.2951	12.2950	0.3119	12.6070		50,306.60 34	50,306.60 34	2.1807		50,361.12 08
Total	41.1168	67.2262	207.5497	0.6278	45.9592	2.4626	48.4217	12.2950	2.4385	14.7336	0.0000	76,811.18 16	76,811.18 16	2.8282	0.4832	77,025.87 86

Village South Specific Plan (Proposed) - Los Angeles-South Coast County, Summer

	ROG	NOx	CO	SO2	Fugitive PM10	Exhaust PM10	PM10 Total	Fugitive PM2.5	Exhaust PM2.5	PM2.5 Total	Bio- CO2	NBio-CO2	Total CO2	CH4	N2O	CO2e
Percent Reduction	0.00	0.00	0.00	0.00	0.00	0.00	0.00	0.00	0.00	0.00	0.00	0.00	0.00	0.00	0.00	0.00

3.0 Construction Detail

Construction Phase

Phase Number	Phase Name	Phase Type	Start Date	End Date	Num Days Week	Num Days	Phase Description
1	Demolition	Demolition	9/1/2021	10/12/2021	5	30	
2	Site Preparation	Site Preparation	10/13/2021	11/9/2021	5	20	
3	Grading	Grading	11/10/2021	1/11/2022	5	45	
4	Building Construction	Building Construction	1/12/2022	12/12/2023	5	500	
5	Paving	Paving	12/13/2023	1/30/2024	5	35	
6	Architectural Coating	Architectural Coating	1/31/2024	3/19/2024	5	35	

Acres of Grading (Site Preparation Phase): 0

Acres of Grading (Grading Phase): 112.5

Acres of Paving: 0

Residential Indoor: 2,025,000; Residential Outdoor: 675,000; Non-Residential Indoor: 326,400; Non-Residential Outdoor: 108,800; Striped Parking Area: 0 (Architectural Coating – sqft)

OffRoad Equipment

Village South Specific Plan (Proposed) - Los Angeles-South Coast County, Summer

Phase Name	Offroad Equipment Type	Amount	Usage Hours	Horse Power	Load Factor
Demolition	Concrete/Industrial Saws	1	8.00	81	0.73
Demolition	Excavators	3	8.00	158	0.38
Demolition	Rubber Tired Dozers	2	8.00	247	0.40
Site Preparation	Rubber Tired Dozers	3	8.00	247	0.40
Site Preparation	Tractors/Loaders/Backhoes	4	8.00	97	0.37
Grading	Excavators	2	8.00	158	0.38
Grading	Graders	1	8.00	187	0.41
Grading	Rubber Tired Dozers	1	8.00	247	0.40
Grading	Scrapers	2	8.00	367	0.48
Grading	Tractors/Loaders/Backhoes	2	8.00	97	0.37
Building Construction	Cranes	1	7.00	231	0.29
Building Construction	Forklifts	3	8.00	89	0.20
Building Construction	Generator Sets	1	8.00	84	0.74
Building Construction	Tractors/Loaders/Backhoes	3	7.00	97	0.37
Building Construction	Welders	1	8.00	46	0.45
Paving	Pavers	2	8.00	130	0.42
Paving	Paving Equipment	2	8.00	132	0.36
Paving	Rollers	2	8.00	80	0.38
Architectural Coating	Air Compressors	1	6.00	78	0.48

Trips and VMT

Village South Specific Plan (Proposed) - Los Angeles-South Coast County, Summer

Phase Name	Offroad Equipment Count	Worker Trip Number	Vendor Trip Number	Hauling Trip Number	Worker Trip Length	Vendor Trip Length	Hauling Trip Length	Worker Vehicle Class	Vendor Vehicle Class	Hauling Vehicle Class
Demolition	6	15.00	0.00	458.00	14.70	6.90	20.00	LD_Mix	HDT_Mix	HHDT
Site Preparation	7	18.00	0.00	0.00	14.70	6.90	20.00	LD_Mix	HDT_Mix	HHDT
Grading	8	20.00	0.00	0.00	14.70	6.90	20.00	LD_Mix	HDT_Mix	HHDT
Building Construction	9	801.00	143.00	0.00	14.70	6.90	20.00	LD_Mix	HDT_Mix	HHDT
Paving	6	15.00	0.00	0.00	14.70	6.90	20.00	LD_Mix	HDT_Mix	HHDT
Architectural Coating	1	160.00	0.00	0.00	14.70	6.90	20.00	LD_Mix	HDT_Mix	HHDT

3.1 Mitigation Measures Construction

3.2 Demolition - 2021

Unmitigated Construction On-Site

	ROG	NOx	CO	SO2	Fugitive PM10	Exhaust PM10	PM10 Total	Fugitive PM2.5	Exhaust PM2.5	PM2.5 Total	Bio- CO2	NBio- CO2	Total CO2	CH4	N2O	CO2e
Category	lb/day										lb/day					
Fugitive Dust					3.3074	0.0000	3.3074	0.5008	0.0000	0.5008			0.0000			0.0000
Off-Road	3.1651	31.4407	21.5650	0.0388		1.5513	1.5513		1.4411	1.4411		3,747.9449	3,747.9449	1.0549		3,774.3174
Total	3.1651	31.4407	21.5650	0.0388	3.3074	1.5513	4.8588	0.5008	1.4411	1.9419		3,747.9449	3,747.9449	1.0549		3,774.3174

Village South Specific Plan (Proposed) - Los Angeles-South Coast County, Summer

3.2 Demolition - 2021

Unmitigated Construction Off-Site

	ROG	NOx	CO	SO2	Fugitive PM10	Exhaust PM10	PM10 Total	Fugitive PM2.5	Exhaust PM2.5	PM2.5 Total	Bio- CO2	NBio- CO2	Total CO2	CH4	N2O	CO2e
Category	lb/day										lb/day					
Hauling	0.1273	4.0952	0.9602	0.0119	0.2669	0.0126	0.2795	0.0732	0.0120	0.0852		1,292.2413	1,292.2413	0.0877		1,294.4337
Vendor	0.0000	0.0000	0.0000	0.0000	0.0000	0.0000	0.0000	0.0000	0.0000	0.0000		0.0000	0.0000	0.0000		0.0000
Worker	0.0643	0.0442	0.6042	1.7100e-003	0.1677	1.3500e-003	0.1690	0.0445	1.2500e-003	0.0457		170.8155	170.8155	5.0300e-003		170.9413
Total	0.1916	4.1394	1.5644	0.0136	0.4346	0.0139	0.4485	0.1176	0.0133	0.1309		1,463.0568	1,463.0568	0.0927		1,465.3750

Mitigated Construction On-Site

	ROG	NOx	CO	SO2	Fugitive PM10	Exhaust PM10	PM10 Total	Fugitive PM2.5	Exhaust PM2.5	PM2.5 Total	Bio- CO2	NBio- CO2	Total CO2	CH4	N2O	CO2e
Category	lb/day										lb/day					
Fugitive Dust					3.3074	0.0000	3.3074	0.5008	0.0000	0.5008			0.0000			0.0000
Off-Road	3.1651	31.4407	21.5650	0.0388		1.5513	1.5513		1.4411	1.4411	0.0000	3,747.9449	3,747.9449	1.0549		3,774.3174
Total	3.1651	31.4407	21.5650	0.0388	3.3074	1.5513	4.8588	0.5008	1.4411	1.9419	0.0000	3,747.9449	3,747.9449	1.0549		3,774.3174

Village South Specific Plan (Proposed) - Los Angeles-South Coast County, Summer

3.2 Demolition - 2021

Mitigated Construction Off-Site

	ROG	NOx	CO	SO2	Fugitive PM10	Exhaust PM10	PM10 Total	Fugitive PM2.5	Exhaust PM2.5	PM2.5 Total	Bio- CO2	NBio- CO2	Total CO2	CH4	N2O	CO2e
Category	lb/day										lb/day					
Hauling	0.1273	4.0952	0.9602	0.0119	0.2669	0.0126	0.2795	0.0732	0.0120	0.0852		1,292.2413	1,292.2413	0.0877		1,294.4337
Vendor	0.0000	0.0000	0.0000	0.0000	0.0000	0.0000	0.0000	0.0000	0.0000	0.0000		0.0000	0.0000	0.0000		0.0000
Worker	0.0643	0.0442	0.6042	1.7100e-003	0.1677	1.3500e-003	0.1690	0.0445	1.2500e-003	0.0457		170.8155	170.8155	5.0300e-003		170.9413
Total	0.1916	4.1394	1.5644	0.0136	0.4346	0.0139	0.4485	0.1176	0.0133	0.1309		1,463.0568	1,463.0568	0.0927		1,465.3750

3.3 Site Preparation - 2021

Unmitigated Construction On-Site

	ROG	NOx	CO	SO2	Fugitive PM10	Exhaust PM10	PM10 Total	Fugitive PM2.5	Exhaust PM2.5	PM2.5 Total	Bio- CO2	NBio- CO2	Total CO2	CH4	N2O	CO2e
Category	lb/day										lb/day					
Fugitive Dust					18.0663	0.0000	18.0663	9.9307	0.0000	9.9307			0.0000			0.0000
Off-Road	3.8882	40.4971	21.1543	0.0380		2.0445	2.0445		1.8809	1.8809		3,685.6569	3,685.6569	1.1920		3,715.4573
Total	3.8882	40.4971	21.1543	0.0380	18.0663	2.0445	20.1107	9.9307	1.8809	11.8116		3,685.6569	3,685.6569	1.1920		3,715.4573

Village South Specific Plan (Proposed) - Los Angeles-South Coast County, Summer

3.3 Site Preparation - 2021

Unmitigated Construction Off-Site

	ROG	NOx	CO	SO2	Fugitive PM10	Exhaust PM10	PM10 Total	Fugitive PM2.5	Exhaust PM2.5	PM2.5 Total	Bio- CO2	NBio- CO2	Total CO2	CH4	N2O	CO2e
Category	lb/day										lb/day					
Hauling	0.0000	0.0000	0.0000	0.0000	0.0000	0.0000	0.0000	0.0000	0.0000	0.0000		0.0000	0.0000	0.0000		0.0000
Vendor	0.0000	0.0000	0.0000	0.0000	0.0000	0.0000	0.0000	0.0000	0.0000	0.0000		0.0000	0.0000	0.0000		0.0000
Worker	0.0772	0.0530	0.7250	2.0600e-003	0.2012	1.6300e-003	0.2028	0.0534	1.5000e-003	0.0549		204.9786	204.9786	6.0400e-003		205.1296
Total	0.0772	0.0530	0.7250	2.0600e-003	0.2012	1.6300e-003	0.2028	0.0534	1.5000e-003	0.0549		204.9786	204.9786	6.0400e-003		205.1296

Mitigated Construction On-Site

	ROG	NOx	CO	SO2	Fugitive PM10	Exhaust PM10	PM10 Total	Fugitive PM2.5	Exhaust PM2.5	PM2.5 Total	Bio- CO2	NBio- CO2	Total CO2	CH4	N2O	CO2e
Category	lb/day										lb/day					
Fugitive Dust					18.0663	0.0000	18.0663	9.9307	0.0000	9.9307			0.0000			0.0000
Off-Road	3.8882	40.4971	21.1543	0.0380		2.0445	2.0445		1.8809	1.8809	0.0000	3,685.6569	3,685.6569	1.1920		3,715.4573
Total	3.8882	40.4971	21.1543	0.0380	18.0663	2.0445	20.1107	9.9307	1.8809	11.8116	0.0000	3,685.6569	3,685.6569	1.1920		3,715.4573

Village South Specific Plan (Proposed) - Los Angeles-South Coast County, Summer

3.3 Site Preparation - 2021

Mitigated Construction Off-Site

	ROG	NOx	CO	SO2	Fugitive PM10	Exhaust PM10	PM10 Total	Fugitive PM2.5	Exhaust PM2.5	PM2.5 Total	Bio- CO2	NBio- CO2	Total CO2	CH4	N2O	CO2e
Category	lb/day										lb/day					
Hauling	0.0000	0.0000	0.0000	0.0000	0.0000	0.0000	0.0000	0.0000	0.0000	0.0000		0.0000	0.0000	0.0000		0.0000
Vendor	0.0000	0.0000	0.0000	0.0000	0.0000	0.0000	0.0000	0.0000	0.0000	0.0000		0.0000	0.0000	0.0000		0.0000
Worker	0.0772	0.0530	0.7250	2.0600e-003	0.2012	1.6300e-003	0.2028	0.0534	1.5000e-003	0.0549		204.9786	204.9786	6.0400e-003		205.1296
Total	0.0772	0.0530	0.7250	2.0600e-003	0.2012	1.6300e-003	0.2028	0.0534	1.5000e-003	0.0549		204.9786	204.9786	6.0400e-003		205.1296

3.4 Grading - 2021

Unmitigated Construction On-Site

	ROG	NOx	CO	SO2	Fugitive PM10	Exhaust PM10	PM10 Total	Fugitive PM2.5	Exhaust PM2.5	PM2.5 Total	Bio- CO2	NBio- CO2	Total CO2	CH4	N2O	CO2e
Category	lb/day										lb/day					
Fugitive Dust					8.6733	0.0000	8.6733	3.5965	0.0000	3.5965			0.0000			0.0000
Off-Road	4.1912	46.3998	30.8785	0.0620		1.9853	1.9853		1.8265	1.8265		6,007.0434	6,007.0434	1.9428		6,055.6134
Total	4.1912	46.3998	30.8785	0.0620	8.6733	1.9853	10.6587	3.5965	1.8265	5.4230		6,007.0434	6,007.0434	1.9428		6,055.6134

Village South Specific Plan (Proposed) - Los Angeles-South Coast County, Summer

3.4 Grading - 2021

Unmitigated Construction Off-Site

	ROG	NOx	CO	SO2	Fugitive PM10	Exhaust PM10	PM10 Total	Fugitive PM2.5	Exhaust PM2.5	PM2.5 Total	Bio- CO2	NBio- CO2	Total CO2	CH4	N2O	CO2e
Category	lb/day										lb/day					
Hauling	0.0000	0.0000	0.0000	0.0000	0.0000	0.0000	0.0000	0.0000	0.0000	0.0000		0.0000	0.0000	0.0000		0.0000
Vendor	0.0000	0.0000	0.0000	0.0000	0.0000	0.0000	0.0000	0.0000	0.0000	0.0000		0.0000	0.0000	0.0000		0.0000
Worker	0.0857	0.0589	0.8056	2.2900e-003	0.2236	1.8100e-003	0.2254	0.0593	1.6600e-003	0.0610		227.7540	227.7540	6.7100e-003		227.9217
Total	0.0857	0.0589	0.8056	2.2900e-003	0.2236	1.8100e-003	0.2254	0.0593	1.6600e-003	0.0610		227.7540	227.7540	6.7100e-003		227.9217

Mitigated Construction On-Site

	ROG	NOx	CO	SO2	Fugitive PM10	Exhaust PM10	PM10 Total	Fugitive PM2.5	Exhaust PM2.5	PM2.5 Total	Bio- CO2	NBio- CO2	Total CO2	CH4	N2O	CO2e
Category	lb/day										lb/day					
Fugitive Dust					8.6733	0.0000	8.6733	3.5965	0.0000	3.5965			0.0000			0.0000
Off-Road	4.1912	46.3998	30.8785	0.0620		1.9853	1.9853		1.8265	1.8265	0.0000	6,007.0434	6,007.0434	1.9428		6,055.6134
Total	4.1912	46.3998	30.8785	0.0620	8.6733	1.9853	10.6587	3.5965	1.8265	5.4230	0.0000	6,007.0434	6,007.0434	1.9428		6,055.6134

Village South Specific Plan (Proposed) - Los Angeles-South Coast County, Summer

3.4 Grading - 2021

Mitigated Construction Off-Site

	ROG	NOx	CO	SO2	Fugitive PM10	Exhaust PM10	PM10 Total	Fugitive PM2.5	Exhaust PM2.5	PM2.5 Total	Bio- CO2	NBio- CO2	Total CO2	CH4	N2O	CO2e
Category	lb/day										lb/day					
Hauling	0.0000	0.0000	0.0000	0.0000	0.0000	0.0000	0.0000	0.0000	0.0000	0.0000		0.0000	0.0000	0.0000		0.0000
Vendor	0.0000	0.0000	0.0000	0.0000	0.0000	0.0000	0.0000	0.0000	0.0000	0.0000		0.0000	0.0000	0.0000		0.0000
Worker	0.0857	0.0589	0.8056	2.2900e-003	0.2236	1.8100e-003	0.2254	0.0593	1.6600e-003	0.0610		227.7540	227.7540	6.7100e-003		227.9217
Total	0.0857	0.0589	0.8056	2.2900e-003	0.2236	1.8100e-003	0.2254	0.0593	1.6600e-003	0.0610		227.7540	227.7540	6.7100e-003		227.9217

3.4 Grading - 2022

Unmitigated Construction On-Site

	ROG	NOx	CO	SO2	Fugitive PM10	Exhaust PM10	PM10 Total	Fugitive PM2.5	Exhaust PM2.5	PM2.5 Total	Bio- CO2	NBio- CO2	Total CO2	CH4	N2O	CO2e
Category	lb/day										lb/day					
Fugitive Dust					8.6733	0.0000	8.6733	3.5965	0.0000	3.5965			0.0000			0.0000
Off-Road	3.6248	38.8435	29.0415	0.0621		1.6349	1.6349		1.5041	1.5041		6,011.4105	6,011.4105	1.9442		6,060.0158
Total	3.6248	38.8435	29.0415	0.0621	8.6733	1.6349	10.3082	3.5965	1.5041	5.1006		6,011.4105	6,011.4105	1.9442		6,060.0158

Village South Specific Plan (Proposed) - Los Angeles-South Coast County, Summer

3.4 Grading - 2022

Unmitigated Construction Off-Site

	ROG	NOx	CO	SO2	Fugitive PM10	Exhaust PM10	PM10 Total	Fugitive PM2.5	Exhaust PM2.5	PM2.5 Total	Bio- CO2	NBio- CO2	Total CO2	CH4	N2O	CO2e
Category	lb/day										lb/day					
Hauling	0.0000	0.0000	0.0000	0.0000	0.0000	0.0000	0.0000	0.0000	0.0000	0.0000		0.0000	0.0000	0.0000		0.0000
Vendor	0.0000	0.0000	0.0000	0.0000	0.0000	0.0000	0.0000	0.0000	0.0000	0.0000		0.0000	0.0000	0.0000		0.0000
Worker	0.0803	0.0532	0.7432	2.2100e-003	0.2236	1.7500e-003	0.2253	0.0593	1.6100e-003	0.0609		219.7425	219.7425	6.0600e-003		219.8941
Total	0.0803	0.0532	0.7432	2.2100e-003	0.2236	1.7500e-003	0.2253	0.0593	1.6100e-003	0.0609		219.7425	219.7425	6.0600e-003		219.8941

Mitigated Construction On-Site

	ROG	NOx	CO	SO2	Fugitive PM10	Exhaust PM10	PM10 Total	Fugitive PM2.5	Exhaust PM2.5	PM2.5 Total	Bio- CO2	NBio- CO2	Total CO2	CH4	N2O	CO2e
Category	lb/day										lb/day					
Fugitive Dust					8.6733	0.0000	8.6733	3.5965	0.0000	3.5965			0.0000			0.0000
Off-Road	3.6248	38.8435	29.0415	0.0621		1.6349	1.6349		1.5041	1.5041	0.0000	6,011.4105	6,011.4105	1.9442		6,060.0158
Total	3.6248	38.8435	29.0415	0.0621	8.6733	1.6349	10.3082	3.5965	1.5041	5.1006	0.0000	6,011.4105	6,011.4105	1.9442		6,060.0158

Village South Specific Plan (Proposed) - Los Angeles-South Coast County, Summer

3.4 Grading - 2022

Mitigated Construction Off-Site

	ROG	NOx	CO	SO2	Fugitive PM10	Exhaust PM10	PM10 Total	Fugitive PM2.5	Exhaust PM2.5	PM2.5 Total	Bio- CO2	NBio- CO2	Total CO2	CH4	N2O	CO2e
Category	lb/day										lb/day					
Hauling	0.0000	0.0000	0.0000	0.0000	0.0000	0.0000	0.0000	0.0000	0.0000	0.0000		0.0000	0.0000	0.0000		0.0000
Vendor	0.0000	0.0000	0.0000	0.0000	0.0000	0.0000	0.0000	0.0000	0.0000	0.0000		0.0000	0.0000	0.0000		0.0000
Worker	0.0803	0.0532	0.7432	2.2100e-003	0.2236	1.7500e-003	0.2253	0.0593	1.6100e-003	0.0609		219.7425	219.7425	6.0600e-003		219.8941
Total	0.0803	0.0532	0.7432	2.2100e-003	0.2236	1.7500e-003	0.2253	0.0593	1.6100e-003	0.0609		219.7425	219.7425	6.0600e-003		219.8941

3.5 Building Construction - 2022

Unmitigated Construction On-Site

	ROG	NOx	CO	SO2	Fugitive PM10	Exhaust PM10	PM10 Total	Fugitive PM2.5	Exhaust PM2.5	PM2.5 Total	Bio- CO2	NBio- CO2	Total CO2	CH4	N2O	CO2e
Category	lb/day										lb/day					
Off-Road	1.7062	15.6156	16.3634	0.0269		0.8090	0.8090		0.7612	0.7612		2,554.3336	2,554.3336	0.6120		2,569.6322
Total	1.7062	15.6156	16.3634	0.0269		0.8090	0.8090		0.7612	0.7612		2,554.3336	2,554.3336	0.6120		2,569.6322

Village South Specific Plan (Proposed) - Los Angeles-South Coast County, Summer

3.5 Building Construction - 2022

Unmitigated Construction Off-Site

	ROG	NOx	CO	SO2	Fugitive PM10	Exhaust PM10	PM10 Total	Fugitive PM2.5	Exhaust PM2.5	PM2.5 Total	Bio- CO2	NBio- CO2	Total CO2	CH4	N2O	CO2e
Category	lb/day										lb/day					
Hauling	0.0000	0.0000	0.0000	0.0000	0.0000	0.0000	0.0000	0.0000	0.0000	0.0000		0.0000	0.0000	0.0000		0.0000
Vendor	0.4079	13.2032	3.4341	0.0364	0.9155	0.0248	0.9404	0.2636	0.0237	0.2873		3,896.548 2	3,896.548 2	0.2236		3,902.138 4
Worker	3.2162	2.1318	29.7654	0.0883	8.9533	0.0701	9.0234	2.3745	0.0646	2.4390		8,800.685 7	8,800.685 7	0.2429		8,806.758 2
Total	3.6242	15.3350	33.1995	0.1247	9.8688	0.0949	9.9637	2.6381	0.0883	2.7263		12,697.23 39	12,697.23 39	0.4665		12,708.89 66

Mitigated Construction On-Site

	ROG	NOx	CO	SO2	Fugitive PM10	Exhaust PM10	PM10 Total	Fugitive PM2.5	Exhaust PM2.5	PM2.5 Total	Bio- CO2	NBio- CO2	Total CO2	CH4	N2O	CO2e
Category	lb/day										lb/day					
Off-Road	1.7062	15.6156	16.3634	0.0269		0.8090	0.8090		0.7612	0.7612	0.0000	2,554.333 6	2,554.333 6	0.6120		2,569.632 2
Total	1.7062	15.6156	16.3634	0.0269		0.8090	0.8090		0.7612	0.7612	0.0000	2,554.333 6	2,554.333 6	0.6120		2,569.632 2

Village South Specific Plan (Proposed) - Los Angeles-South Coast County, Summer

3.5 Building Construction - 2022

Mitigated Construction Off-Site

	ROG	NOx	CO	SO2	Fugitive PM10	Exhaust PM10	PM10 Total	Fugitive PM2.5	Exhaust PM2.5	PM2.5 Total	Bio- CO2	NBio- CO2	Total CO2	CH4	N2O	CO2e
Category	lb/day										lb/day					
Hauling	0.0000	0.0000	0.0000	0.0000	0.0000	0.0000	0.0000	0.0000	0.0000	0.0000		0.0000	0.0000	0.0000		0.0000
Vendor	0.4079	13.2032	3.4341	0.0364	0.9155	0.0248	0.9404	0.2636	0.0237	0.2873		3,896.548 2	3,896.548 2	0.2236		3,902.138 4
Worker	3.2162	2.1318	29.7654	0.0883	8.9533	0.0701	9.0234	2.3745	0.0646	2.4390		8,800.685 7	8,800.685 7	0.2429		8,806.758 2
Total	3.6242	15.3350	33.1995	0.1247	9.8688	0.0949	9.9637	2.6381	0.0883	2.7263		12,697.23 39	12,697.23 39	0.4665		12,708.89 66

3.5 Building Construction - 2023

Unmitigated Construction On-Site

	ROG	NOx	CO	SO2	Fugitive PM10	Exhaust PM10	PM10 Total	Fugitive PM2.5	Exhaust PM2.5	PM2.5 Total	Bio- CO2	NBio- CO2	Total CO2	CH4	N2O	CO2e
Category	lb/day										lb/day					
Off-Road	1.5728	14.3849	16.2440	0.0269		0.6997	0.6997		0.6584	0.6584		2,555.209 9	2,555.209 9	0.6079		2,570.406 1
Total	1.5728	14.3849	16.2440	0.0269		0.6997	0.6997		0.6584	0.6584		2,555.209 9	2,555.209 9	0.6079		2,570.406 1

Village South Specific Plan (Proposed) - Los Angeles-South Coast County, Summer

3.5 Building Construction - 2023

Unmitigated Construction Off-Site

	ROG	NOx	CO	SO2	Fugitive PM10	Exhaust PM10	PM10 Total	Fugitive PM2.5	Exhaust PM2.5	PM2.5 Total	Bio- CO2	NBio- CO2	Total CO2	CH4	N2O	CO2e
Category	lb/day										lb/day					
Hauling	0.0000	0.0000	0.0000	0.0000	0.0000	0.0000	0.0000	0.0000	0.0000	0.0000		0.0000	0.0000	0.0000		0.0000
Vendor	0.3027	10.0181	3.1014	0.0352	0.9156	0.0116	0.9271	0.2636	0.0111	0.2747		3,773.876 2	3,773.876 2	0.1982		3,778.830 0
Worker	3.0203	1.9287	27.4113	0.0851	8.9533	0.0681	9.0214	2.3745	0.0627	2.4372		8,478.440 8	8,478.440 8	0.2190		8,483.916 0
Total	3.3229	11.9468	30.5127	0.1203	9.8688	0.0797	9.9485	2.6381	0.0738	2.7118		12,252.31 70	12,252.31 70	0.4172		12,262.74 60

Mitigated Construction On-Site

	ROG	NOx	CO	SO2	Fugitive PM10	Exhaust PM10	PM10 Total	Fugitive PM2.5	Exhaust PM2.5	PM2.5 Total	Bio- CO2	NBio- CO2	Total CO2	CH4	N2O	CO2e
Category	lb/day										lb/day					
Off-Road	1.5728	14.3849	16.2440	0.0269		0.6997	0.6997		0.6584	0.6584	0.0000	2,555.209 9	2,555.209 9	0.6079		2,570.406 1
Total	1.5728	14.3849	16.2440	0.0269		0.6997	0.6997		0.6584	0.6584	0.0000	2,555.209 9	2,555.209 9	0.6079		2,570.406 1

Village South Specific Plan (Proposed) - Los Angeles-South Coast County, Summer

3.5 Building Construction - 2023

Mitigated Construction Off-Site

	ROG	NOx	CO	SO2	Fugitive PM10	Exhaust PM10	PM10 Total	Fugitive PM2.5	Exhaust PM2.5	PM2.5 Total	Bio- CO2	NBio- CO2	Total CO2	CH4	N2O	CO2e
Category	lb/day										lb/day					
Hauling	0.0000	0.0000	0.0000	0.0000	0.0000	0.0000	0.0000	0.0000	0.0000	0.0000		0.0000	0.0000	0.0000		0.0000
Vendor	0.3027	10.0181	3.1014	0.0352	0.9156	0.0116	0.9271	0.2636	0.0111	0.2747		3,773.876 2	3,773.876 2	0.1982		3,778.830 0
Worker	3.0203	1.9287	27.4113	0.0851	8.9533	0.0681	9.0214	2.3745	0.0627	2.4372		8,478.440 8	8,478.440 8	0.2190		8,483.916 0
Total	3.3229	11.9468	30.5127	0.1203	9.8688	0.0797	9.9485	2.6381	0.0738	2.7118		12,252.31 70	12,252.31 70	0.4172		12,262.74 60

3.6 Paving - 2023

Unmitigated Construction On-Site

	ROG	NOx	CO	SO2	Fugitive PM10	Exhaust PM10	PM10 Total	Fugitive PM2.5	Exhaust PM2.5	PM2.5 Total	Bio- CO2	NBio- CO2	Total CO2	CH4	N2O	CO2e
Category	lb/day										lb/day					
Off-Road	1.0327	10.1917	14.5842	0.0228		0.5102	0.5102		0.4694	0.4694		2,207.584 1	2,207.584 1	0.7140		2,225.433 6
Paving	0.0000					0.0000	0.0000		0.0000	0.0000			0.0000			0.0000
Total	1.0327	10.1917	14.5842	0.0228		0.5102	0.5102		0.4694	0.4694		2,207.584 1	2,207.584 1	0.7140		2,225.433 6

Village South Specific Plan (Proposed) - Los Angeles-South Coast County, Summer

3.6 Paving - 2023

Unmitigated Construction Off-Site

	ROG	NOx	CO	SO2	Fugitive PM10	Exhaust PM10	PM10 Total	Fugitive PM2.5	Exhaust PM2.5	PM2.5 Total	Bio- CO2	NBio- CO2	Total CO2	CH4	N2O	CO2e
Category	lb/day										lb/day					
Hauling	0.0000	0.0000	0.0000	0.0000	0.0000	0.0000	0.0000	0.0000	0.0000	0.0000		0.0000	0.0000	0.0000		0.0000
Vendor	0.0000	0.0000	0.0000	0.0000	0.0000	0.0000	0.0000	0.0000	0.0000	0.0000		0.0000	0.0000	0.0000		0.0000
Worker	0.0566	0.0361	0.5133	1.5900e-003	0.1677	1.2800e-003	0.1689	0.0445	1.1700e-003	0.0456		158.7723	158.7723	4.1000e-003		158.8748
Total	0.0566	0.0361	0.5133	1.5900e-003	0.1677	1.2800e-003	0.1689	0.0445	1.1700e-003	0.0456		158.7723	158.7723	4.1000e-003		158.8748

Mitigated Construction On-Site

	ROG	NOx	CO	SO2	Fugitive PM10	Exhaust PM10	PM10 Total	Fugitive PM2.5	Exhaust PM2.5	PM2.5 Total	Bio- CO2	NBio- CO2	Total CO2	CH4	N2O	CO2e
Category	lb/day										lb/day					
Off-Road	1.0327	10.1917	14.5842	0.0228		0.5102	0.5102		0.4694	0.4694	0.0000	2,207.5841	2,207.5841	0.7140		2,225.4336
Paving	0.0000					0.0000	0.0000		0.0000	0.0000			0.0000			0.0000
Total	1.0327	10.1917	14.5842	0.0228		0.5102	0.5102		0.4694	0.4694	0.0000	2,207.5841	2,207.5841	0.7140		2,225.4336

Village South Specific Plan (Proposed) - Los Angeles-South Coast County, Summer

3.6 Paving - 2023

Mitigated Construction Off-Site

	ROG	NOx	CO	SO2	Fugitive PM10	Exhaust PM10	PM10 Total	Fugitive PM2.5	Exhaust PM2.5	PM2.5 Total	Bio- CO2	NBio- CO2	Total CO2	CH4	N2O	CO2e
Category	lb/day										lb/day					
Hauling	0.0000	0.0000	0.0000	0.0000	0.0000	0.0000	0.0000	0.0000	0.0000	0.0000		0.0000	0.0000	0.0000		0.0000
Vendor	0.0000	0.0000	0.0000	0.0000	0.0000	0.0000	0.0000	0.0000	0.0000	0.0000		0.0000	0.0000	0.0000		0.0000
Worker	0.0566	0.0361	0.5133	1.5900e-003	0.1677	1.2800e-003	0.1689	0.0445	1.1700e-003	0.0456		158.7723	158.7723	4.1000e-003		158.8748
Total	0.0566	0.0361	0.5133	1.5900e-003	0.1677	1.2800e-003	0.1689	0.0445	1.1700e-003	0.0456		158.7723	158.7723	4.1000e-003		158.8748

3.6 Paving - 2024

Unmitigated Construction On-Site

	ROG	NOx	CO	SO2	Fugitive PM10	Exhaust PM10	PM10 Total	Fugitive PM2.5	Exhaust PM2.5	PM2.5 Total	Bio- CO2	NBio- CO2	Total CO2	CH4	N2O	CO2e
Category	lb/day										lb/day					
Off-Road	0.9882	9.5246	14.6258	0.0228		0.4685	0.4685		0.4310	0.4310		2,207.5472	2,207.5472	0.7140		2,225.3963
Paving	0.0000					0.0000	0.0000		0.0000	0.0000			0.0000			0.0000
Total	0.9882	9.5246	14.6258	0.0228		0.4685	0.4685		0.4310	0.4310		2,207.5472	2,207.5472	0.7140		2,225.3963

Village South Specific Plan (Proposed) - Los Angeles-South Coast County, Summer

3.6 Paving - 2024

Unmitigated Construction Off-Site

	ROG	NOx	CO	SO2	Fugitive PM10	Exhaust PM10	PM10 Total	Fugitive PM2.5	Exhaust PM2.5	PM2.5 Total	Bio- CO2	NBio- CO2	Total CO2	CH4	N2O	CO2e
Category	lb/day										lb/day					
Hauling	0.0000	0.0000	0.0000	0.0000	0.0000	0.0000	0.0000	0.0000	0.0000	0.0000		0.0000	0.0000	0.0000		0.0000
Vendor	0.0000	0.0000	0.0000	0.0000	0.0000	0.0000	0.0000	0.0000	0.0000	0.0000		0.0000	0.0000	0.0000		0.0000
Worker	0.0535	0.0329	0.4785	1.5400e-003	0.1677	1.2600e-003	0.1689	0.0445	1.1600e-003	0.0456		153.8517	153.8517	3.7600e-003		153.9458
Total	0.0535	0.0329	0.4785	1.5400e-003	0.1677	1.2600e-003	0.1689	0.0445	1.1600e-003	0.0456		153.8517	153.8517	3.7600e-003		153.9458

Mitigated Construction On-Site

	ROG	NOx	CO	SO2	Fugitive PM10	Exhaust PM10	PM10 Total	Fugitive PM2.5	Exhaust PM2.5	PM2.5 Total	Bio- CO2	NBio- CO2	Total CO2	CH4	N2O	CO2e
Category	lb/day										lb/day					
Off-Road	0.9882	9.5246	14.6258	0.0228		0.4685	0.4685		0.4310	0.4310	0.0000	2,207.5472	2,207.5472	0.7140		2,225.3963
Paving	0.0000					0.0000	0.0000		0.0000	0.0000			0.0000			0.0000
Total	0.9882	9.5246	14.6258	0.0228		0.4685	0.4685		0.4310	0.4310	0.0000	2,207.5472	2,207.5472	0.7140		2,225.3963

Village South Specific Plan (Proposed) - Los Angeles-South Coast County, Summer

3.6 Paving - 2024

Mitigated Construction Off-Site

	ROG	NOx	CO	SO2	Fugitive PM10	Exhaust PM10	PM10 Total	Fugitive PM2.5	Exhaust PM2.5	PM2.5 Total	Bio- CO2	NBio- CO2	Total CO2	CH4	N2O	CO2e
Category	lb/day										lb/day					
Hauling	0.0000	0.0000	0.0000	0.0000	0.0000	0.0000	0.0000	0.0000	0.0000	0.0000		0.0000	0.0000	0.0000		0.0000
Vendor	0.0000	0.0000	0.0000	0.0000	0.0000	0.0000	0.0000	0.0000	0.0000	0.0000		0.0000	0.0000	0.0000		0.0000
Worker	0.0535	0.0329	0.4785	1.5400e-003	0.1677	1.2600e-003	0.1689	0.0445	1.1600e-003	0.0456		153.8517	153.8517	3.7600e-003		153.9458
Total	0.0535	0.0329	0.4785	1.5400e-003	0.1677	1.2600e-003	0.1689	0.0445	1.1600e-003	0.0456		153.8517	153.8517	3.7600e-003		153.9458

3.7 Architectural Coating - 2024

Unmitigated Construction On-Site

	ROG	NOx	CO	SO2	Fugitive PM10	Exhaust PM10	PM10 Total	Fugitive PM2.5	Exhaust PM2.5	PM2.5 Total	Bio- CO2	NBio- CO2	Total CO2	CH4	N2O	CO2e
Category	lb/day										lb/day					
Archit. Coating	236.4115					0.0000	0.0000		0.0000	0.0000			0.0000			0.0000
Off-Road	0.1808	1.2188	1.8101	2.9700e-003		0.0609	0.0609		0.0609	0.0609		281.4481	281.4481	0.0159		281.8443
Total	236.5923	1.2188	1.8101	2.9700e-003		0.0609	0.0609		0.0609	0.0609		281.4481	281.4481	0.0159		281.8443

Village South Specific Plan (Proposed) - Los Angeles-South Coast County, Summer

3.7 Architectural Coating - 2024

Unmitigated Construction Off-Site

	ROG	NOx	CO	SO2	Fugitive PM10	Exhaust PM10	PM10 Total	Fugitive PM2.5	Exhaust PM2.5	PM2.5 Total	Bio- CO2	NBio- CO2	Total CO2	CH4	N2O	CO2e
Category	lb/day										lb/day					
Hauling	0.0000	0.0000	0.0000	0.0000	0.0000	0.0000	0.0000	0.0000	0.0000	0.0000		0.0000	0.0000	0.0000		0.0000
Vendor	0.0000	0.0000	0.0000	0.0000	0.0000	0.0000	0.0000	0.0000	0.0000	0.0000		0.0000	0.0000	0.0000		0.0000
Worker	0.5707	0.3513	5.1044	0.0165	1.7884	0.0134	1.8018	0.4743	0.0123	0.4866		1,641.085 2	1,641.085 2	0.0401		1,642.088 6
Total	0.5707	0.3513	5.1044	0.0165	1.7884	0.0134	1.8018	0.4743	0.0123	0.4866		1,641.085 2	1,641.085 2	0.0401		1,642.088 6

Mitigated Construction On-Site

	ROG	NOx	CO	SO2	Fugitive PM10	Exhaust PM10	PM10 Total	Fugitive PM2.5	Exhaust PM2.5	PM2.5 Total	Bio- CO2	NBio- CO2	Total CO2	CH4	N2O	CO2e
Category	lb/day										lb/day					
Archit. Coating	236.4115					0.0000	0.0000		0.0000	0.0000			0.0000			0.0000
Off-Road	0.1808	1.2188	1.8101	2.9700e-003		0.0609	0.0609		0.0609	0.0609	0.0000	281.4481	281.4481	0.0159		281.8443
Total	236.5923	1.2188	1.8101	2.9700e-003		0.0609	0.0609		0.0609	0.0609	0.0000	281.4481	281.4481	0.0159		281.8443

Village South Specific Plan (Proposed) - Los Angeles-South Coast County, Summer

3.7 Architectural Coating - 2024

Mitigated Construction Off-Site

	ROG	NOx	CO	SO2	Fugitive PM10	Exhaust PM10	PM10 Total	Fugitive PM2.5	Exhaust PM2.5	PM2.5 Total	Bio- CO2	NBio- CO2	Total CO2	CH4	N2O	CO2e
Category	lb/day										lb/day					
Hauling	0.0000	0.0000	0.0000	0.0000	0.0000	0.0000	0.0000	0.0000	0.0000	0.0000		0.0000	0.0000	0.0000		0.0000
Vendor	0.0000	0.0000	0.0000	0.0000	0.0000	0.0000	0.0000	0.0000	0.0000	0.0000		0.0000	0.0000	0.0000		0.0000
Worker	0.5707	0.3513	5.1044	0.0165	1.7884	0.0134	1.8018	0.4743	0.0123	0.4866		1,641.085 2	1,641.085 2	0.0401		1,642.088 6
Total	0.5707	0.3513	5.1044	0.0165	1.7884	0.0134	1.8018	0.4743	0.0123	0.4866		1,641.085 2	1,641.085 2	0.0401		1,642.088 6

4.0 Operational Detail - Mobile

4.1 Mitigation Measures Mobile

Village South Specific Plan (Proposed) - Los Angeles-South Coast County, Summer

	ROG	NOx	CO	SO2	Fugitive PM10	Exhaust PM10	PM10 Total	Fugitive PM2.5	Exhaust PM2.5	PM2.5 Total	Bio- CO2	NBio- CO2	Total CO2	CH4	N2O	CO2e
Category	lb/day										lb/day					
Mitigated	9.8489	45.4304	114.8495	0.4917	45.9592	0.3360	46.2951	12.2950	0.3119	12.6070		50,306.60 34	50,306.60 34	2.1807		50,361.12 08
Unmitigated	9.8489	45.4304	114.8495	0.4917	45.9592	0.3360	46.2951	12.2950	0.3119	12.6070		50,306.60 34	50,306.60 34	2.1807		50,361.12 08

4.2 Trip Summary Information

Land Use	Average Daily Trip Rate			Unmitigated	Mitigated
	Weekday	Saturday	Sunday	Annual VMT	Annual VMT
Apartments Low Rise	145.75	154.25	154.00	506,227	506,227
Apartments Mid Rise	4,026.75	3,773.25	4075.50	13,660,065	13,660,065
General Office Building	288.45	62.55	31.05	706,812	706,812
High Turnover (Sit Down Restaurant)	2,368.80	2,873.52	2817.72	3,413,937	3,413,937
Hotel	192.00	187.50	160.00	445,703	445,703
Quality Restaurant	501.12	511.92	461.20	707,488	707,488
Regional Shopping Center	528.08	601.44	357.84	1,112,221	1,112,221
Total	8,050.95	8,164.43	8,057.31	20,552,452	20,552,452

4.3 Trip Type Information

Village South Specific Plan (Proposed) - Los Angeles-South Coast County, Summer

Land Use	Miles			Trip %			Trip Purpose %		
	H-W or C-W	H-S or C-C	H-O or C-NW	H-W or C-W	H-S or C-C	H-O or C-NW	Primary	Diverted	Pass-by
Apartments Low Rise	14.70	5.90	8.70	40.20	19.20	40.60	86	11	3
Apartments Mid Rise	14.70	5.90	8.70	40.20	19.20	40.60	86	11	3
General Office Building	16.60	8.40	6.90	33.00	48.00	19.00	77	19	4
High Turnover (Sit Down Restaurant)	16.60	8.40	6.90	8.50	72.50	19.00	37	20	43
Hotel	16.60	8.40	6.90	19.40	61.60	19.00	58	38	4
Quality Restaurant	16.60	8.40	6.90	12.00	69.00	19.00	38	18	44
Regional Shopping Center	16.60	8.40	6.90	16.30	64.70	19.00	54	35	11

4.4 Fleet Mix

Land Use	LDA	LDT1	LDT2	MDV	LHD1	LHD2	MHD	HHD	OBUS	UBUS	MCY	SBUS	MH
Apartments Low Rise	0.543088	0.044216	0.209971	0.116369	0.014033	0.006332	0.021166	0.033577	0.002613	0.001817	0.005285	0.000712	0.000821
Apartments Mid Rise	0.543088	0.044216	0.209971	0.116369	0.014033	0.006332	0.021166	0.033577	0.002613	0.001817	0.005285	0.000712	0.000821
General Office Building	0.543088	0.044216	0.209971	0.116369	0.014033	0.006332	0.021166	0.033577	0.002613	0.001817	0.005285	0.000712	0.000821
High Turnover (Sit Down Restaurant)	0.543088	0.044216	0.209971	0.116369	0.014033	0.006332	0.021166	0.033577	0.002613	0.001817	0.005285	0.000712	0.000821
Hotel	0.543088	0.044216	0.209971	0.116369	0.014033	0.006332	0.021166	0.033577	0.002613	0.001817	0.005285	0.000712	0.000821
Quality Restaurant	0.543088	0.044216	0.209971	0.116369	0.014033	0.006332	0.021166	0.033577	0.002613	0.001817	0.005285	0.000712	0.000821
Regional Shopping Center	0.543088	0.044216	0.209971	0.116369	0.014033	0.006332	0.021166	0.033577	0.002613	0.001817	0.005285	0.000712	0.000821

5.0 Energy Detail

Historical Energy Use: N

5.1 Mitigation Measures Energy

Village South Specific Plan (Proposed) - Los Angeles-South Coast County, Summer

	ROG	NOx	CO	SO2	Fugitive PM10	Exhaust PM10	PM10 Total	Fugitive PM2.5	Exhaust PM2.5	PM2.5 Total	Bio- CO2	NBio- CO2	Total CO2	CH4	N2O	CO2e
Category	lb/day										lb/day					
NaturalGas Mitigated	0.7660	6.7462	4.2573	0.0418		0.5292	0.5292		0.5292	0.5292		8,355.983 2	8,355.983 2	0.1602	0.1532	8,405.638 7
NaturalGas Unmitigated	0.7660	6.7462	4.2573	0.0418		0.5292	0.5292		0.5292	0.5292		8,355.983 2	8,355.983 2	0.1602	0.1532	8,405.638 7

Village South Specific Plan (Proposed) - Los Angeles-South Coast County, Summer

5.2 Energy by Land Use - NaturalGas

Unmitigated

	NaturalGas Use	ROG	NOx	CO	SO2	Fugitive PM10	Exhaust PM10	PM10 Total	Fugitive PM2.5	Exhaust PM2.5	PM2.5 Total	Bio- CO2	NBio- CO2	Total CO2	CH4	N2O	CO2e
Land Use	kBTU/yr	lb/day										lb/day					
Apartments Low Rise	1119.16	0.0121	0.1031	0.0439	6.6000e-004		8.3400e-003	8.3400e-003		8.3400e-003	8.3400e-003		131.6662	131.6662	2.5200e-003	2.4100e-003	132.4486
Apartments Mid Rise	35784.3	0.3859	3.2978	1.4033	0.0211		0.2666	0.2666		0.2666	0.2666		4,209.9164	4,209.9164	0.0807	0.0772	4,234.9339
General Office Building	1283.42	0.0138	0.1258	0.1057	7.5000e-004		9.5600e-003	9.5600e-003		9.5600e-003	9.5600e-003		150.9911	150.9911	2.8900e-003	2.7700e-003	151.8884
High Turnover (Sit Down Restaurant)	22759.9	0.2455	2.2314	1.8743	0.0134		0.1696	0.1696		0.1696	0.1696		2,677.6342	2,677.6342	0.0513	0.0491	2,693.5460
Hotel	4769.72	0.0514	0.4676	0.3928	2.8100e-003		0.0355	0.0355		0.0355	0.0355		561.1436	561.1436	0.0108	0.0103	564.4782
Quality Restaurant	5057.75	0.0545	0.4959	0.4165	2.9800e-003		0.0377	0.0377		0.0377	0.0377		595.0298	595.0298	0.0114	0.0109	598.5658
Regional Shopping Center	251.616	2.7100e-003	0.0247	0.0207	1.5000e-004		1.8700e-003	1.8700e-003		1.8700e-003	1.8700e-003		29.6019	29.6019	5.7000e-004	5.4000e-004	29.7778
Total		0.7660	6.7463	4.2573	0.0418		0.5292	0.5292		0.5292	0.5292		8,355.9832	8,355.9832	0.1602	0.1532	8,405.6387

Village South Specific Plan (Proposed) - Los Angeles-South Coast County, Summer

5.2 Energy by Land Use - NaturalGas

Mitigated

	NaturalGas Use	ROG	NOx	CO	SO2	Fugitive PM10	Exhaust PM10	PM10 Total	Fugitive PM2.5	Exhaust PM2.5	PM2.5 Total	Bio- CO2	NBio- CO2	Total CO2	CH4	N2O	CO2e
Land Use	kBTU/yr	lb/day										lb/day					
Apartments Low Rise	1.11916	0.0121	0.1031	0.0439	6.6000e-004		8.3400e-003	8.3400e-003		8.3400e-003	8.3400e-003		131.6662	131.6662	2.5200e-003	2.4100e-003	132.4486
Apartments Mid Rise	35.7843	0.3859	3.2978	1.4033	0.0211		0.2666	0.2666		0.2666	0.2666		4,209.9164	4,209.9164	0.0807	0.0772	4,234.9339
General Office Building	1.28342	0.0138	0.1258	0.1057	7.5000e-004		9.5600e-003	9.5600e-003		9.5600e-003	9.5600e-003		150.9911	150.9911	2.8900e-003	2.7700e-003	151.8884
High Turnover (Sit Down Restaurant)	22.7599	0.2455	2.2314	1.8743	0.0134		0.1696	0.1696		0.1696	0.1696		2,677.6342	2,677.6342	0.0513	0.0491	2,693.5460
Hotel	4.76972	0.0514	0.4676	0.3928	2.8100e-003		0.0355	0.0355		0.0355	0.0355		561.1436	561.1436	0.0108	0.0103	564.4782
Quality Restaurant	5.05775	0.0545	0.4959	0.4165	2.9800e-003		0.0377	0.0377		0.0377	0.0377		595.0298	595.0298	0.0114	0.0109	598.5658
Regional Shopping Center	0.251616	2.7100e-003	0.0247	0.0207	1.5000e-004		1.8700e-003	1.8700e-003		1.8700e-003	1.8700e-003		29.6019	29.6019	5.7000e-004	5.4000e-004	29.7778
Total		0.7660	6.7463	4.2573	0.0418		0.5292	0.5292		0.5292	0.5292		8,355.9832	8,355.9832	0.1602	0.1532	8,405.6387

6.0 Area Detail

6.1 Mitigation Measures Area

Village South Specific Plan (Proposed) - Los Angeles-South Coast County, Summer

	ROG	NOx	CO	SO2	Fugitive PM10	Exhaust PM10	PM10 Total	Fugitive PM2.5	Exhaust PM2.5	PM2.5 Total	Bio- CO2	NBio- CO2	Total CO2	CH4	N2O	CO2e
Category	lb/day										lb/day					
Mitigated	30.5020	15.0496	88.4430	0.0944		1.5974	1.5974		1.5974	1.5974	0.0000	18,148.5950	18,148.5950	0.4874	0.3300	18,259.1192
Unmitigated	30.5020	15.0496	88.4430	0.0944		1.5974	1.5974		1.5974	1.5974	0.0000	18,148.5950	18,148.5950	0.4874	0.3300	18,259.1192

6.2 Area by SubCategory

Unmitigated

	ROG	NOx	CO	SO2	Fugitive PM10	Exhaust PM10	PM10 Total	Fugitive PM2.5	Exhaust PM2.5	PM2.5 Total	Bio- CO2	NBio- CO2	Total CO2	CH4	N2O	CO2e
SubCategory	lb/day										lb/day					
Architectural Coating	2.2670					0.0000	0.0000		0.0000	0.0000			0.0000			0.0000
Consumer Products	24.1085					0.0000	0.0000		0.0000	0.0000			0.0000			0.0000
Hearth	1.6500	14.1000	6.0000	0.0900		1.1400	1.1400		1.1400	1.1400	0.0000	18,000.0000	18,000.0000	0.3450	0.3300	18,106.9650
Landscaping	2.4766	0.9496	82.4430	4.3600e-003		0.4574	0.4574		0.4574	0.4574		148.5950	148.5950	0.1424		152.1542
Total	30.5020	15.0496	88.4430	0.0944		1.5974	1.5974		1.5974	1.5974	0.0000	18,148.5950	18,148.5950	0.4874	0.3300	18,259.1192

Village South Specific Plan (Proposed) - Los Angeles-South Coast County, Summer

6.2 Area by SubCategory

Mitigated

	ROG	NOx	CO	SO2	Fugitive PM10	Exhaust PM10	PM10 Total	Fugitive PM2.5	Exhaust PM2.5	PM2.5 Total	Bio- CO2	NBio- CO2	Total CO2	CH4	N2O	CO2e
SubCategory	lb/day										lb/day					
Architectural Coating	2.2670					0.0000	0.0000		0.0000	0.0000			0.0000			0.0000
Consumer Products	24.1085					0.0000	0.0000		0.0000	0.0000			0.0000			0.0000
Hearth	1.6500	14.1000	6.0000	0.0900		1.1400	1.1400		1.1400	1.1400	0.0000	18,000.0000	18,000.0000	0.3450	0.3300	18,106.9650
Landscaping	2.4766	0.9496	82.4430	4.3600e-003		0.4574	0.4574		0.4574	0.4574		148.5950	148.5950	0.1424		152.1542
Total	30.5020	15.0496	88.4430	0.0944		1.5974	1.5974		1.5974	1.5974	0.0000	18,148.5950	18,148.5950	0.4874	0.3300	18,259.1192

7.0 Water Detail

7.1 Mitigation Measures Water

8.0 Waste Detail

8.1 Mitigation Measures Waste

9.0 Operational Offroad

Equipment Type	Number	Hours/Day	Days/Year	Horse Power	Load Factor	Fuel Type
----------------	--------	-----------	-----------	-------------	-------------	-----------

10.0 Stationary Equipment

Village South Specific Plan (Proposed) - Los Angeles-South Coast County, Summer

Fire Pumps and Emergency Generators

Equipment Type	Number	Hours/Day	Hours/Year	Horse Power	Load Factor	Fuel Type
----------------	--------	-----------	------------	-------------	-------------	-----------

Boilers

Equipment Type	Number	Heat Input/Day	Heat Input/Year	Boiler Rating	Fuel Type
----------------	--------	----------------	-----------------	---------------	-----------

User Defined Equipment

Equipment Type	Number
----------------	--------

11.0 Vegetation

Village South Specific Plan (Proposed) - Los Angeles-South Coast County, Winter

Village South Specific Plan (Proposed)
Los Angeles-South Coast County, Winter

1.0 Project Characteristics

1.1 Land Usage

Land Uses	Size	Metric	Lot Acreage	Floor Surface Area	Population
General Office Building	45.00	1000sqft	1.03	45,000.00	0
High Turnover (Sit Down Restaurant)	36.00	1000sqft	0.83	36,000.00	0
Hotel	50.00	Room	1.67	72,600.00	0
Quality Restaurant	8.00	1000sqft	0.18	8,000.00	0
Apartments Low Rise	25.00	Dwelling Unit	1.56	25,000.00	72
Apartments Mid Rise	975.00	Dwelling Unit	25.66	975,000.00	2789
Regional Shopping Center	56.00	1000sqft	1.29	56,000.00	0

1.2 Other Project Characteristics

Urbanization	Urban	Wind Speed (m/s)	2.2	Precipitation Freq (Days)	33
Climate Zone	9			Operational Year	2028
Utility Company	Southern California Edison				
CO2 Intensity (lb/MW hr)	702.44	CH4 Intensity (lb/MW hr)	0.029	N2O Intensity (lb/MW hr)	0.006

1.3 User Entered Comments & Non-Default Data

Village South Specific Plan (Proposed) - Los Angeles-South Coast County, Winter

Project Characteristics - Consistent with the DEIR's model.

Land Use - See SWAPE comment regarding residential and retail land uses.

Construction Phase - See SWAPE comment regarding individual construction phase lengths.

Demolition - Consistent with the DEIR's model. See SWAPE comment regarding demolition.

Vehicle Trips - Saturday trips consistent with the DEIR's model. See SWAPE comment regarding weekday and Sunday trips.

Woodstoves - Woodstoves and wood-burning fireplaces consistent with the DEIR's model. See SWAPE comment regarding gas fireplaces.

Energy Use -

Construction Off-road Equipment Mitigation - See SWAPE comment on construction-related mitigation.

Area Mitigation - See SWAPE comment regarding operational mitigation measures.

Water Mitigation - See SWAPE comment regarding operational mitigation measures.

Table Name	Column Name	Default Value	New Value
tblFireplaces	FireplaceWoodMass	1,019.20	0.00
tblFireplaces	FireplaceWoodMass	1,019.20	0.00
tblFireplaces	NumberWood	1.25	0.00
tblFireplaces	NumberWood	48.75	0.00
tblVehicleTrips	ST_TR	7.16	6.17
tblVehicleTrips	ST_TR	6.39	3.87
tblVehicleTrips	ST_TR	2.46	1.39
tblVehicleTrips	ST_TR	158.37	79.82
tblVehicleTrips	ST_TR	8.19	3.75
tblVehicleTrips	ST_TR	94.36	63.99
tblVehicleTrips	ST_TR	49.97	10.74
tblVehicleTrips	SU_TR	6.07	6.16
tblVehicleTrips	SU_TR	5.86	4.18
tblVehicleTrips	SU_TR	1.05	0.69
tblVehicleTrips	SU_TR	131.84	78.27

Village South Specific Plan (Proposed) - Los Angeles-South Coast County, Winter

tblVehicleTrips	SU_TR	5.95	3.20
tblVehicleTrips	SU_TR	72.16	57.65
tblVehicleTrips	SU_TR	25.24	6.39
tblVehicleTrips	WD_TR	6.59	5.83
tblVehicleTrips	WD_TR	6.65	4.13
tblVehicleTrips	WD_TR	11.03	6.41
tblVehicleTrips	WD_TR	127.15	65.80
tblVehicleTrips	WD_TR	8.17	3.84
tblVehicleTrips	WD_TR	89.95	62.64
tblVehicleTrips	WD_TR	42.70	9.43
tblWoodstoves	NumberCatalytic	1.25	0.00
tblWoodstoves	NumberCatalytic	48.75	0.00
tblWoodstoves	NumberNoncatalytic	1.25	0.00
tblWoodstoves	NumberNoncatalytic	48.75	0.00
tblWoodstoves	WoodstoveDayYear	25.00	0.00
tblWoodstoves	WoodstoveDayYear	25.00	0.00
tblWoodstoves	WoodstoveWoodMass	999.60	0.00
tblWoodstoves	WoodstoveWoodMass	999.60	0.00

2.0 Emissions Summary

Village South Specific Plan (Proposed) - Los Angeles-South Coast County, Winter

2.1 Overall Construction (Maximum Daily Emission)

Unmitigated Construction

	ROG	NOx	CO	SO2	Fugitive PM10	Exhaust PM10	PM10 Total	Fugitive PM2.5	Exhaust PM2.5	PM2.5 Total	Bio- CO2	NBio- CO2	Total CO2	CH4	N2O	CO2e
Year	lb/day										lb/day					
2021	4.2865	46.4651	31.6150	0.0642	18.2675	2.0461	20.3135	9.9840	1.8824	11.8664	0.0000	6,221.4937	6,221.4937	1.9491	0.0000	6,270.2214
2022	5.7218	38.9024	47.3319	0.1455	9.8688	1.6366	10.7736	3.6558	1.5057	5.1615	0.0000	14,630.3099	14,630.3099	1.9499	0.0000	14,657.2663
2023	5.2705	26.4914	44.5936	0.1413	9.8688	0.7800	10.6488	2.6381	0.7328	3.3708	0.0000	14,210.3424	14,210.3424	1.0230	0.0000	14,235.9160
2024	237.2328	9.5610	15.0611	0.0243	1.7884	0.4698	1.8628	0.4743	0.4322	0.5476	0.0000	2,352.4178	2,352.4178	0.7175	0.0000	2,370.3550
Maximum	237.2328	46.4651	47.3319	0.1455	18.2675	2.0461	20.3135	9.9840	1.8824	11.8664	0.0000	14,630.3099	14,630.3099	1.9499	0.0000	14,657.2663

Village South Specific Plan (Proposed) - Los Angeles-South Coast County, Winter

2.2 Overall Operational

Unmitigated Operational

	ROG	NOx	CO	SO2	Fugitive PM10	Exhaust PM10	PM10 Total	Fugitive PM2.5	Exhaust PM2.5	PM2.5 Total	Bio- CO2	NBio- CO2	Total CO2	CH4	N2O	CO2e
Category	lb/day										lb/day					
Area	30.5020	15.0496	88.4430	0.0944		1.5974	1.5974		1.5974	1.5974	0.0000	18,148.5950	18,148.5950	0.4874	0.3300	18,259.1192
Energy	0.7660	6.7462	4.2573	0.0418		0.5292	0.5292		0.5292	0.5292		8,355.9832	8,355.9832	0.1602	0.1532	8,405.6387
Mobile	9.5233	45.9914	110.0422	0.4681	45.9592	0.3373	46.2965	12.2950	0.3132	12.6083		47,917.8005	47,917.8005	2.1953		47,972.6839
Total	40.7912	67.7872	202.7424	0.6043	45.9592	2.4640	48.4231	12.2950	2.4399	14.7349	0.0000	74,422.3787	74,422.3787	2.8429	0.4832	74,637.4417

Mitigated Operational

	ROG	NOx	CO	SO2	Fugitive PM10	Exhaust PM10	PM10 Total	Fugitive PM2.5	Exhaust PM2.5	PM2.5 Total	Bio- CO2	NBio- CO2	Total CO2	CH4	N2O	CO2e
Category	lb/day										lb/day					
Area	30.5020	15.0496	88.4430	0.0944		1.5974	1.5974		1.5974	1.5974	0.0000	18,148.5950	18,148.5950	0.4874	0.3300	18,259.1192
Energy	0.7660	6.7462	4.2573	0.0418		0.5292	0.5292		0.5292	0.5292		8,355.9832	8,355.9832	0.1602	0.1532	8,405.6387
Mobile	9.5233	45.9914	110.0422	0.4681	45.9592	0.3373	46.2965	12.2950	0.3132	12.6083		47,917.8005	47,917.8005	2.1953		47,972.6839
Total	40.7912	67.7872	202.7424	0.6043	45.9592	2.4640	48.4231	12.2950	2.4399	14.7349	0.0000	74,422.3787	74,422.3787	2.8429	0.4832	74,637.4417

Village South Specific Plan (Proposed) - Los Angeles-South Coast County, Winter

	ROG	NOx	CO	SO2	Fugitive PM10	Exhaust PM10	PM10 Total	Fugitive PM2.5	Exhaust PM2.5	PM2.5 Total	Bio- CO2	NBio-CO2	Total CO2	CH4	N2O	CO2e
Percent Reduction	0.00	0.00	0.00	0.00	0.00	0.00	0.00	0.00	0.00	0.00	0.00	0.00	0.00	0.00	0.00	0.00

3.0 Construction Detail

Construction Phase

Phase Number	Phase Name	Phase Type	Start Date	End Date	Num Days Week	Num Days	Phase Description
1	Demolition	Demolition	9/1/2021	10/12/2021	5	30	
2	Site Preparation	Site Preparation	10/13/2021	11/9/2021	5	20	
3	Grading	Grading	11/10/2021	1/11/2022	5	45	
4	Building Construction	Building Construction	1/12/2022	12/12/2023	5	500	
5	Paving	Paving	12/13/2023	1/30/2024	5	35	
6	Architectural Coating	Architectural Coating	1/31/2024	3/19/2024	5	35	

Acres of Grading (Site Preparation Phase): 0

Acres of Grading (Grading Phase): 112.5

Acres of Paving: 0

Residential Indoor: 2,025,000; Residential Outdoor: 675,000; Non-Residential Indoor: 326,400; Non-Residential Outdoor: 108,800; Striped Parking Area: 0 (Architectural Coating – sqft)

OffRoad Equipment

Village South Specific Plan (Proposed) - Los Angeles-South Coast County, Winter

Phase Name	Offroad Equipment Type	Amount	Usage Hours	Horse Power	Load Factor
Demolition	Concrete/Industrial Saws	1	8.00	81	0.73
Demolition	Excavators	3	8.00	158	0.38
Demolition	Rubber Tired Dozers	2	8.00	247	0.40
Site Preparation	Rubber Tired Dozers	3	8.00	247	0.40
Site Preparation	Tractors/Loaders/Backhoes	4	8.00	97	0.37
Grading	Excavators	2	8.00	158	0.38
Grading	Graders	1	8.00	187	0.41
Grading	Rubber Tired Dozers	1	8.00	247	0.40
Grading	Scrapers	2	8.00	367	0.48
Grading	Tractors/Loaders/Backhoes	2	8.00	97	0.37
Building Construction	Cranes	1	7.00	231	0.29
Building Construction	Forklifts	3	8.00	89	0.20
Building Construction	Generator Sets	1	8.00	84	0.74
Building Construction	Tractors/Loaders/Backhoes	3	7.00	97	0.37
Building Construction	Welders	1	8.00	46	0.45
Paving	Pavers	2	8.00	130	0.42
Paving	Paving Equipment	2	8.00	132	0.36
Paving	Rollers	2	8.00	80	0.38
Architectural Coating	Air Compressors	1	6.00	78	0.48

Trips and VMT

Village South Specific Plan (Proposed) - Los Angeles-South Coast County, Winter

Phase Name	Offroad Equipment Count	Worker Trip Number	Vendor Trip Number	Hauling Trip Number	Worker Trip Length	Vendor Trip Length	Hauling Trip Length	Worker Vehicle Class	Vendor Vehicle Class	Hauling Vehicle Class
Demolition	6	15.00	0.00	458.00	14.70	6.90	20.00	LD_Mix	HDT_Mix	HHDT
Site Preparation	7	18.00	0.00	0.00	14.70	6.90	20.00	LD_Mix	HDT_Mix	HHDT
Grading	8	20.00	0.00	0.00	14.70	6.90	20.00	LD_Mix	HDT_Mix	HHDT
Building Construction	9	801.00	143.00	0.00	14.70	6.90	20.00	LD_Mix	HDT_Mix	HHDT
Paving	6	15.00	0.00	0.00	14.70	6.90	20.00	LD_Mix	HDT_Mix	HHDT
Architectural Coating	1	160.00	0.00	0.00	14.70	6.90	20.00	LD_Mix	HDT_Mix	HHDT

3.1 Mitigation Measures Construction

3.2 Demolition - 2021

Unmitigated Construction On-Site

	ROG	NOx	CO	SO2	Fugitive PM10	Exhaust PM10	PM10 Total	Fugitive PM2.5	Exhaust PM2.5	PM2.5 Total	Bio- CO2	NBio- CO2	Total CO2	CH4	N2O	CO2e
Category	lb/day										lb/day					
Fugitive Dust					3.3074	0.0000	3.3074	0.5008	0.0000	0.5008			0.0000			0.0000
Off-Road	3.1651	31.4407	21.5650	0.0388		1.5513	1.5513		1.4411	1.4411		3,747.9449	3,747.9449	1.0549		3,774.3174
Total	3.1651	31.4407	21.5650	0.0388	3.3074	1.5513	4.8588	0.5008	1.4411	1.9419		3,747.9449	3,747.9449	1.0549		3,774.3174

Village South Specific Plan (Proposed) - Los Angeles-South Coast County, Winter

3.2 Demolition - 2021

Unmitigated Construction Off-Site

	ROG	NOx	CO	SO2	Fugitive PM10	Exhaust PM10	PM10 Total	Fugitive PM2.5	Exhaust PM2.5	PM2.5 Total	Bio- CO2	NBio- CO2	Total CO2	CH4	N2O	CO2e
Category	lb/day										lb/day					
Hauling	0.1304	4.1454	1.0182	0.0117	0.2669	0.0128	0.2797	0.0732	0.0122	0.0854		1,269.8555	1,269.8555	0.0908		1,272.1252
Vendor	0.0000	0.0000	0.0000	0.0000	0.0000	0.0000	0.0000	0.0000	0.0000	0.0000		0.0000	0.0000	0.0000		0.0000
Worker	0.0715	0.0489	0.5524	1.6100e-003	0.1677	1.3500e-003	0.1690	0.0445	1.2500e-003	0.0457		160.8377	160.8377	4.7300e-003		160.9560
Total	0.2019	4.1943	1.5706	0.0133	0.4346	0.0141	0.4487	0.1176	0.0135	0.1311		1,430.6932	1,430.6932	0.0955		1,433.0812

Mitigated Construction On-Site

	ROG	NOx	CO	SO2	Fugitive PM10	Exhaust PM10	PM10 Total	Fugitive PM2.5	Exhaust PM2.5	PM2.5 Total	Bio- CO2	NBio- CO2	Total CO2	CH4	N2O	CO2e
Category	lb/day										lb/day					
Fugitive Dust					3.3074	0.0000	3.3074	0.5008	0.0000	0.5008			0.0000			0.0000
Off-Road	3.1651	31.4407	21.5650	0.0388		1.5513	1.5513		1.4411	1.4411	0.0000	3,747.9449	3,747.9449	1.0549		3,774.3174
Total	3.1651	31.4407	21.5650	0.0388	3.3074	1.5513	4.8588	0.5008	1.4411	1.9419	0.0000	3,747.9449	3,747.9449	1.0549		3,774.3174

Village South Specific Plan (Proposed) - Los Angeles-South Coast County, Winter

3.2 Demolition - 2021

Mitigated Construction Off-Site

	ROG	NOx	CO	SO2	Fugitive PM10	Exhaust PM10	PM10 Total	Fugitive PM2.5	Exhaust PM2.5	PM2.5 Total	Bio- CO2	NBio- CO2	Total CO2	CH4	N2O	CO2e
Category	lb/day										lb/day					
Hauling	0.1304	4.1454	1.0182	0.0117	0.2669	0.0128	0.2797	0.0732	0.0122	0.0854		1,269.8555	1,269.8555	0.0908		1,272.1252
Vendor	0.0000	0.0000	0.0000	0.0000	0.0000	0.0000	0.0000	0.0000	0.0000	0.0000		0.0000	0.0000	0.0000		0.0000
Worker	0.0715	0.0489	0.5524	1.6100e-003	0.1677	1.3500e-003	0.1690	0.0445	1.2500e-003	0.0457		160.8377	160.8377	4.7300e-003		160.9560
Total	0.2019	4.1943	1.5706	0.0133	0.4346	0.0141	0.4487	0.1176	0.0135	0.1311		1,430.6932	1,430.6932	0.0955		1,433.0812

3.3 Site Preparation - 2021

Unmitigated Construction On-Site

	ROG	NOx	CO	SO2	Fugitive PM10	Exhaust PM10	PM10 Total	Fugitive PM2.5	Exhaust PM2.5	PM2.5 Total	Bio- CO2	NBio- CO2	Total CO2	CH4	N2O	CO2e
Category	lb/day										lb/day					
Fugitive Dust					18.0663	0.0000	18.0663	9.9307	0.0000	9.9307			0.0000			0.0000
Off-Road	3.8882	40.4971	21.1543	0.0380		2.0445	2.0445		1.8809	1.8809		3,685.6569	3,685.6569	1.1920		3,715.4573
Total	3.8882	40.4971	21.1543	0.0380	18.0663	2.0445	20.1107	9.9307	1.8809	11.8116		3,685.6569	3,685.6569	1.1920		3,715.4573

Village South Specific Plan (Proposed) - Los Angeles-South Coast County, Winter

3.3 Site Preparation - 2021

Unmitigated Construction Off-Site

	ROG	NOx	CO	SO2	Fugitive PM10	Exhaust PM10	PM10 Total	Fugitive PM2.5	Exhaust PM2.5	PM2.5 Total	Bio- CO2	NBio- CO2	Total CO2	CH4	N2O	CO2e
Category	lb/day										lb/day					
Hauling	0.0000	0.0000	0.0000	0.0000	0.0000	0.0000	0.0000	0.0000	0.0000	0.0000		0.0000	0.0000	0.0000		0.0000
Vendor	0.0000	0.0000	0.0000	0.0000	0.0000	0.0000	0.0000	0.0000	0.0000	0.0000		0.0000	0.0000	0.0000		0.0000
Worker	0.0858	0.0587	0.6629	1.9400e-003	0.2012	1.6300e-003	0.2028	0.0534	1.5000e-003	0.0549		193.0052	193.0052	5.6800e-003		193.1472
Total	0.0858	0.0587	0.6629	1.9400e-003	0.2012	1.6300e-003	0.2028	0.0534	1.5000e-003	0.0549		193.0052	193.0052	5.6800e-003		193.1472

Mitigated Construction On-Site

	ROG	NOx	CO	SO2	Fugitive PM10	Exhaust PM10	PM10 Total	Fugitive PM2.5	Exhaust PM2.5	PM2.5 Total	Bio- CO2	NBio- CO2	Total CO2	CH4	N2O	CO2e
Category	lb/day										lb/day					
Fugitive Dust					18.0663	0.0000	18.0663	9.9307	0.0000	9.9307			0.0000			0.0000
Off-Road	3.8882	40.4971	21.1543	0.0380		2.0445	2.0445		1.8809	1.8809	0.0000	3,685.6569	3,685.6569	1.1920		3,715.4573
Total	3.8882	40.4971	21.1543	0.0380	18.0663	2.0445	20.1107	9.9307	1.8809	11.8116	0.0000	3,685.6569	3,685.6569	1.1920		3,715.4573

Village South Specific Plan (Proposed) - Los Angeles-South Coast County, Winter

3.3 Site Preparation - 2021

Mitigated Construction Off-Site

	ROG	NOx	CO	SO2	Fugitive PM10	Exhaust PM10	PM10 Total	Fugitive PM2.5	Exhaust PM2.5	PM2.5 Total	Bio- CO2	NBio- CO2	Total CO2	CH4	N2O	CO2e
Category	lb/day										lb/day					
Hauling	0.0000	0.0000	0.0000	0.0000	0.0000	0.0000	0.0000	0.0000	0.0000	0.0000		0.0000	0.0000	0.0000		0.0000
Vendor	0.0000	0.0000	0.0000	0.0000	0.0000	0.0000	0.0000	0.0000	0.0000	0.0000		0.0000	0.0000	0.0000		0.0000
Worker	0.0858	0.0587	0.6629	1.9400e-003	0.2012	1.6300e-003	0.2028	0.0534	1.5000e-003	0.0549		193.0052	193.0052	5.6800e-003		193.1472
Total	0.0858	0.0587	0.6629	1.9400e-003	0.2012	1.6300e-003	0.2028	0.0534	1.5000e-003	0.0549		193.0052	193.0052	5.6800e-003		193.1472

3.4 Grading - 2021

Unmitigated Construction On-Site

	ROG	NOx	CO	SO2	Fugitive PM10	Exhaust PM10	PM10 Total	Fugitive PM2.5	Exhaust PM2.5	PM2.5 Total	Bio- CO2	NBio- CO2	Total CO2	CH4	N2O	CO2e
Category	lb/day										lb/day					
Fugitive Dust					8.6733	0.0000	8.6733	3.5965	0.0000	3.5965			0.0000			0.0000
Off-Road	4.1912	46.3998	30.8785	0.0620		1.9853	1.9853		1.8265	1.8265		6,007.0434	6,007.0434	1.9428		6,055.6134
Total	4.1912	46.3998	30.8785	0.0620	8.6733	1.9853	10.6587	3.5965	1.8265	5.4230		6,007.0434	6,007.0434	1.9428		6,055.6134

Village South Specific Plan (Proposed) - Los Angeles-South Coast County, Winter

3.4 Grading - 2021

Unmitigated Construction Off-Site

	ROG	NOx	CO	SO2	Fugitive PM10	Exhaust PM10	PM10 Total	Fugitive PM2.5	Exhaust PM2.5	PM2.5 Total	Bio- CO2	NBio- CO2	Total CO2	CH4	N2O	CO2e
Category	lb/day										lb/day					
Hauling	0.0000	0.0000	0.0000	0.0000	0.0000	0.0000	0.0000	0.0000	0.0000	0.0000		0.0000	0.0000	0.0000		0.0000
Vendor	0.0000	0.0000	0.0000	0.0000	0.0000	0.0000	0.0000	0.0000	0.0000	0.0000		0.0000	0.0000	0.0000		0.0000
Worker	0.0954	0.0652	0.7365	2.1500e-003	0.2236	1.8100e-003	0.2254	0.0593	1.6600e-003	0.0610		214.4502	214.4502	6.3100e-003		214.6080
Total	0.0954	0.0652	0.7365	2.1500e-003	0.2236	1.8100e-003	0.2254	0.0593	1.6600e-003	0.0610		214.4502	214.4502	6.3100e-003		214.6080

Mitigated Construction On-Site

	ROG	NOx	CO	SO2	Fugitive PM10	Exhaust PM10	PM10 Total	Fugitive PM2.5	Exhaust PM2.5	PM2.5 Total	Bio- CO2	NBio- CO2	Total CO2	CH4	N2O	CO2e
Category	lb/day										lb/day					
Fugitive Dust					8.6733	0.0000	8.6733	3.5965	0.0000	3.5965			0.0000			0.0000
Off-Road	4.1912	46.3998	30.8785	0.0620		1.9853	1.9853		1.8265	1.8265	0.0000	6,007.0434	6,007.0434	1.9428		6,055.6134
Total	4.1912	46.3998	30.8785	0.0620	8.6733	1.9853	10.6587	3.5965	1.8265	5.4230	0.0000	6,007.0434	6,007.0434	1.9428		6,055.6134

Village South Specific Plan (Proposed) - Los Angeles-South Coast County, Winter

3.4 Grading - 2021

Mitigated Construction Off-Site

	ROG	NOx	CO	SO2	Fugitive PM10	Exhaust PM10	PM10 Total	Fugitive PM2.5	Exhaust PM2.5	PM2.5 Total	Bio- CO2	NBio- CO2	Total CO2	CH4	N2O	CO2e
Category	lb/day										lb/day					
Hauling	0.0000	0.0000	0.0000	0.0000	0.0000	0.0000	0.0000	0.0000	0.0000	0.0000		0.0000	0.0000	0.0000		0.0000
Vendor	0.0000	0.0000	0.0000	0.0000	0.0000	0.0000	0.0000	0.0000	0.0000	0.0000		0.0000	0.0000	0.0000		0.0000
Worker	0.0954	0.0652	0.7365	2.1500e-003	0.2236	1.8100e-003	0.2254	0.0593	1.6600e-003	0.0610		214.4502	214.4502	6.3100e-003		214.6080
Total	0.0954	0.0652	0.7365	2.1500e-003	0.2236	1.8100e-003	0.2254	0.0593	1.6600e-003	0.0610		214.4502	214.4502	6.3100e-003		214.6080

3.4 Grading - 2022

Unmitigated Construction On-Site

	ROG	NOx	CO	SO2	Fugitive PM10	Exhaust PM10	PM10 Total	Fugitive PM2.5	Exhaust PM2.5	PM2.5 Total	Bio- CO2	NBio- CO2	Total CO2	CH4	N2O	CO2e
Category	lb/day										lb/day					
Fugitive Dust					8.6733	0.0000	8.6733	3.5965	0.0000	3.5965			0.0000			0.0000
Off-Road	3.6248	38.8435	29.0415	0.0621		1.6349	1.6349		1.5041	1.5041		6,011.4105	6,011.4105	1.9442		6,060.0158
Total	3.6248	38.8435	29.0415	0.0621	8.6733	1.6349	10.3082	3.5965	1.5041	5.1006		6,011.4105	6,011.4105	1.9442		6,060.0158

Village South Specific Plan (Proposed) - Los Angeles-South Coast County, Winter

3.4 Grading - 2022

Unmitigated Construction Off-Site

	ROG	NOx	CO	SO2	Fugitive PM10	Exhaust PM10	PM10 Total	Fugitive PM2.5	Exhaust PM2.5	PM2.5 Total	Bio- CO2	NBio- CO2	Total CO2	CH4	N2O	CO2e
Category	lb/day										lb/day					
Hauling	0.0000	0.0000	0.0000	0.0000	0.0000	0.0000	0.0000	0.0000	0.0000	0.0000		0.0000	0.0000	0.0000		0.0000
Vendor	0.0000	0.0000	0.0000	0.0000	0.0000	0.0000	0.0000	0.0000	0.0000	0.0000		0.0000	0.0000	0.0000		0.0000
Worker	0.0896	0.0589	0.6784	2.0800e-003	0.2236	1.7500e-003	0.2253	0.0593	1.6100e-003	0.0609		206.9139	206.9139	5.7000e-003		207.0563
Total	0.0896	0.0589	0.6784	2.0800e-003	0.2236	1.7500e-003	0.2253	0.0593	1.6100e-003	0.0609		206.9139	206.9139	5.7000e-003		207.0563

Mitigated Construction On-Site

	ROG	NOx	CO	SO2	Fugitive PM10	Exhaust PM10	PM10 Total	Fugitive PM2.5	Exhaust PM2.5	PM2.5 Total	Bio- CO2	NBio- CO2	Total CO2	CH4	N2O	CO2e
Category	lb/day										lb/day					
Fugitive Dust					8.6733	0.0000	8.6733	3.5965	0.0000	3.5965			0.0000			0.0000
Off-Road	3.6248	38.8435	29.0415	0.0621		1.6349	1.6349		1.5041	1.5041	0.0000	6,011.4105	6,011.4105	1.9442		6,060.0158
Total	3.6248	38.8435	29.0415	0.0621	8.6733	1.6349	10.3082	3.5965	1.5041	5.1006	0.0000	6,011.4105	6,011.4105	1.9442		6,060.0158

Village South Specific Plan (Proposed) - Los Angeles-South Coast County, Winter

3.4 Grading - 2022

Mitigated Construction Off-Site

	ROG	NOx	CO	SO2	Fugitive PM10	Exhaust PM10	PM10 Total	Fugitive PM2.5	Exhaust PM2.5	PM2.5 Total	Bio- CO2	NBio- CO2	Total CO2	CH4	N2O	CO2e
Category	lb/day										lb/day					
Hauling	0.0000	0.0000	0.0000	0.0000	0.0000	0.0000	0.0000	0.0000	0.0000	0.0000		0.0000	0.0000	0.0000		0.0000
Vendor	0.0000	0.0000	0.0000	0.0000	0.0000	0.0000	0.0000	0.0000	0.0000	0.0000		0.0000	0.0000	0.0000		0.0000
Worker	0.0896	0.0589	0.6784	2.0800e-003	0.2236	1.7500e-003	0.2253	0.0593	1.6100e-003	0.0609		206.9139	206.9139	5.7000e-003		207.0563
Total	0.0896	0.0589	0.6784	2.0800e-003	0.2236	1.7500e-003	0.2253	0.0593	1.6100e-003	0.0609		206.9139	206.9139	5.7000e-003		207.0563

3.5 Building Construction - 2022

Unmitigated Construction On-Site

	ROG	NOx	CO	SO2	Fugitive PM10	Exhaust PM10	PM10 Total	Fugitive PM2.5	Exhaust PM2.5	PM2.5 Total	Bio- CO2	NBio- CO2	Total CO2	CH4	N2O	CO2e
Category	lb/day										lb/day					
Off-Road	1.7062	15.6156	16.3634	0.0269		0.8090	0.8090		0.7612	0.7612		2,554.3336	2,554.3336	0.6120		2,569.6322
Total	1.7062	15.6156	16.3634	0.0269		0.8090	0.8090		0.7612	0.7612		2,554.3336	2,554.3336	0.6120		2,569.6322

Village South Specific Plan (Proposed) - Los Angeles-South Coast County, Winter

3.5 Building Construction - 2022

Unmitigated Construction Off-Site

	ROG	NOx	CO	SO2	Fugitive PM10	Exhaust PM10	PM10 Total	Fugitive PM2.5	Exhaust PM2.5	PM2.5 Total	Bio- CO2	NBio- CO2	Total CO2	CH4	N2O	CO2e
Category	lb/day										lb/day					
Hauling	0.0000	0.0000	0.0000	0.0000	0.0000	0.0000	0.0000	0.0000	0.0000	0.0000		0.0000	0.0000	0.0000		0.0000
Vendor	0.4284	13.1673	3.8005	0.0354	0.9155	0.0256	0.9412	0.2636	0.0245	0.2881		3,789.0750	3,789.0750	0.2381		3,795.0283
Worker	3.5872	2.3593	27.1680	0.0832	8.9533	0.0701	9.0234	2.3745	0.0646	2.4390		8,286.9013	8,286.9013	0.2282		8,292.6058
Total	4.0156	15.5266	30.9685	0.1186	9.8688	0.0957	9.9645	2.6381	0.0891	2.7271		12,075.9763	12,075.9763	0.4663		12,087.6341

Mitigated Construction On-Site

	ROG	NOx	CO	SO2	Fugitive PM10	Exhaust PM10	PM10 Total	Fugitive PM2.5	Exhaust PM2.5	PM2.5 Total	Bio- CO2	NBio- CO2	Total CO2	CH4	N2O	CO2e
Category	lb/day										lb/day					
Off-Road	1.7062	15.6156	16.3634	0.0269		0.8090	0.8090		0.7612	0.7612	0.0000	2,554.3336	2,554.3336	0.6120		2,569.6322
Total	1.7062	15.6156	16.3634	0.0269		0.8090	0.8090		0.7612	0.7612	0.0000	2,554.3336	2,554.3336	0.6120		2,569.6322

Village South Specific Plan (Proposed) - Los Angeles-South Coast County, Winter

3.5 Building Construction - 2022

Mitigated Construction Off-Site

	ROG	NOx	CO	SO2	Fugitive PM10	Exhaust PM10	PM10 Total	Fugitive PM2.5	Exhaust PM2.5	PM2.5 Total	Bio- CO2	NBio- CO2	Total CO2	CH4	N2O	CO2e
Category	lb/day										lb/day					
Hauling	0.0000	0.0000	0.0000	0.0000	0.0000	0.0000	0.0000	0.0000	0.0000	0.0000		0.0000	0.0000	0.0000		0.0000
Vendor	0.4284	13.1673	3.8005	0.0354	0.9155	0.0256	0.9412	0.2636	0.0245	0.2881		3,789.0750	3,789.0750	0.2381		3,795.0283
Worker	3.5872	2.3593	27.1680	0.0832	8.9533	0.0701	9.0234	2.3745	0.0646	2.4390		8,286.9013	8,286.9013	0.2282		8,292.6058
Total	4.0156	15.5266	30.9685	0.1186	9.8688	0.0957	9.9645	2.6381	0.0891	2.7271		12,075.9763	12,075.9763	0.4663		12,087.6341

3.5 Building Construction - 2023

Unmitigated Construction On-Site

	ROG	NOx	CO	SO2	Fugitive PM10	Exhaust PM10	PM10 Total	Fugitive PM2.5	Exhaust PM2.5	PM2.5 Total	Bio- CO2	NBio- CO2	Total CO2	CH4	N2O	CO2e
Category	lb/day										lb/day					
Off-Road	1.5728	14.3849	16.2440	0.0269		0.6997	0.6997		0.6584	0.6584		2,555.2099	2,555.2099	0.6079		2,570.4061
Total	1.5728	14.3849	16.2440	0.0269		0.6997	0.6997		0.6584	0.6584		2,555.2099	2,555.2099	0.6079		2,570.4061

Village South Specific Plan (Proposed) - Los Angeles-South Coast County, Winter

3.5 Building Construction - 2023

Unmitigated Construction Off-Site

	ROG	NOx	CO	SO2	Fugitive PM10	Exhaust PM10	PM10 Total	Fugitive PM2.5	Exhaust PM2.5	PM2.5 Total	Bio- CO2	NBio- CO2	Total CO2	CH4	N2O	CO2e
Category	lb/day										lb/day					
Hauling	0.0000	0.0000	0.0000	0.0000	0.0000	0.0000	0.0000	0.0000	0.0000	0.0000		0.0000	0.0000	0.0000		0.0000
Vendor	0.3183	9.9726	3.3771	0.0343	0.9156	0.0122	0.9277	0.2636	0.0116	0.2752		3,671.4007	3,671.4007	0.2096		3,676.6417
Worker	3.3795	2.1338	24.9725	0.0801	8.9533	0.0681	9.0214	2.3745	0.0627	2.4372		7,983.7318	7,983.7318	0.2055		7,988.8683
Total	3.6978	12.1065	28.3496	0.1144	9.8688	0.0803	9.9491	2.6381	0.0743	2.7124		11,655.1325	11,655.1325	0.4151		11,665.5099

Mitigated Construction On-Site

	ROG	NOx	CO	SO2	Fugitive PM10	Exhaust PM10	PM10 Total	Fugitive PM2.5	Exhaust PM2.5	PM2.5 Total	Bio- CO2	NBio- CO2	Total CO2	CH4	N2O	CO2e
Category	lb/day										lb/day					
Off-Road	1.5728	14.3849	16.2440	0.0269		0.6997	0.6997		0.6584	0.6584	0.0000	2,555.2099	2,555.2099	0.6079		2,570.4061
Total	1.5728	14.3849	16.2440	0.0269		0.6997	0.6997		0.6584	0.6584	0.0000	2,555.2099	2,555.2099	0.6079		2,570.4061

Village South Specific Plan (Proposed) - Los Angeles-South Coast County, Winter

3.5 Building Construction - 2023

Mitigated Construction Off-Site

	ROG	NOx	CO	SO2	Fugitive PM10	Exhaust PM10	PM10 Total	Fugitive PM2.5	Exhaust PM2.5	PM2.5 Total	Bio- CO2	NBio- CO2	Total CO2	CH4	N2O	CO2e
Category	lb/day										lb/day					
Hauling	0.0000	0.0000	0.0000	0.0000	0.0000	0.0000	0.0000	0.0000	0.0000	0.0000		0.0000	0.0000	0.0000		0.0000
Vendor	0.3183	9.9726	3.3771	0.0343	0.9156	0.0122	0.9277	0.2636	0.0116	0.2752		3,671.4007	3,671.4007	0.2096		3,676.6417
Worker	3.3795	2.1338	24.9725	0.0801	8.9533	0.0681	9.0214	2.3745	0.0627	2.4372		7,983.7318	7,983.7318	0.2055		7,988.8683
Total	3.6978	12.1065	28.3496	0.1144	9.8688	0.0803	9.9491	2.6381	0.0743	2.7124		11,655.1325	11,655.1325	0.4151		11,665.5099

3.6 Paving - 2023

Unmitigated Construction On-Site

	ROG	NOx	CO	SO2	Fugitive PM10	Exhaust PM10	PM10 Total	Fugitive PM2.5	Exhaust PM2.5	PM2.5 Total	Bio- CO2	NBio- CO2	Total CO2	CH4	N2O	CO2e
Category	lb/day										lb/day					
Off-Road	1.0327	10.1917	14.5842	0.0228		0.5102	0.5102		0.4694	0.4694		2,207.5841	2,207.5841	0.7140		2,225.4336
Paving	0.0000					0.0000	0.0000		0.0000	0.0000			0.0000			0.0000
Total	1.0327	10.1917	14.5842	0.0228		0.5102	0.5102		0.4694	0.4694		2,207.5841	2,207.5841	0.7140		2,225.4336

Village South Specific Plan (Proposed) - Los Angeles-South Coast County, Winter

3.6 Paving - 2023

Unmitigated Construction Off-Site

	ROG	NOx	CO	SO2	Fugitive PM10	Exhaust PM10	PM10 Total	Fugitive PM2.5	Exhaust PM2.5	PM2.5 Total	Bio- CO2	NBio- CO2	Total CO2	CH4	N2O	CO2e
Category	lb/day										lb/day					
Hauling	0.0000	0.0000	0.0000	0.0000	0.0000	0.0000	0.0000	0.0000	0.0000	0.0000		0.0000	0.0000	0.0000		0.0000
Vendor	0.0000	0.0000	0.0000	0.0000	0.0000	0.0000	0.0000	0.0000	0.0000	0.0000		0.0000	0.0000	0.0000		0.0000
Worker	0.0633	0.0400	0.4677	1.5000e-003	0.1677	1.2800e-003	0.1689	0.0445	1.1700e-003	0.0456		149.5081	149.5081	3.8500e-003		149.6043
Total	0.0633	0.0400	0.4677	1.5000e-003	0.1677	1.2800e-003	0.1689	0.0445	1.1700e-003	0.0456		149.5081	149.5081	3.8500e-003		149.6043

Mitigated Construction On-Site

	ROG	NOx	CO	SO2	Fugitive PM10	Exhaust PM10	PM10 Total	Fugitive PM2.5	Exhaust PM2.5	PM2.5 Total	Bio- CO2	NBio- CO2	Total CO2	CH4	N2O	CO2e
Category	lb/day										lb/day					
Off-Road	1.0327	10.1917	14.5842	0.0228		0.5102	0.5102		0.4694	0.4694	0.0000	2,207.5841	2,207.5841	0.7140		2,225.4336
Paving	0.0000					0.0000	0.0000		0.0000	0.0000			0.0000			0.0000
Total	1.0327	10.1917	14.5842	0.0228		0.5102	0.5102		0.4694	0.4694	0.0000	2,207.5841	2,207.5841	0.7140		2,225.4336

Village South Specific Plan (Proposed) - Los Angeles-South Coast County, Winter

3.6 Paving - 2023

Mitigated Construction Off-Site

	ROG	NOx	CO	SO2	Fugitive PM10	Exhaust PM10	PM10 Total	Fugitive PM2.5	Exhaust PM2.5	PM2.5 Total	Bio- CO2	NBio- CO2	Total CO2	CH4	N2O	CO2e
Category	lb/day										lb/day					
Hauling	0.0000	0.0000	0.0000	0.0000	0.0000	0.0000	0.0000	0.0000	0.0000	0.0000		0.0000	0.0000	0.0000		0.0000
Vendor	0.0000	0.0000	0.0000	0.0000	0.0000	0.0000	0.0000	0.0000	0.0000	0.0000		0.0000	0.0000	0.0000		0.0000
Worker	0.0633	0.0400	0.4677	1.5000e-003	0.1677	1.2800e-003	0.1689	0.0445	1.1700e-003	0.0456		149.5081	149.5081	3.8500e-003		149.6043
Total	0.0633	0.0400	0.4677	1.5000e-003	0.1677	1.2800e-003	0.1689	0.0445	1.1700e-003	0.0456		149.5081	149.5081	3.8500e-003		149.6043

3.6 Paving - 2024

Unmitigated Construction On-Site

	ROG	NOx	CO	SO2	Fugitive PM10	Exhaust PM10	PM10 Total	Fugitive PM2.5	Exhaust PM2.5	PM2.5 Total	Bio- CO2	NBio- CO2	Total CO2	CH4	N2O	CO2e
Category	lb/day										lb/day					
Off-Road	0.9882	9.5246	14.6258	0.0228		0.4685	0.4685		0.4310	0.4310		2,207.5472	2,207.5472	0.7140		2,225.3963
Paving	0.0000					0.0000	0.0000		0.0000	0.0000			0.0000			0.0000
Total	0.9882	9.5246	14.6258	0.0228		0.4685	0.4685		0.4310	0.4310		2,207.5472	2,207.5472	0.7140		2,225.3963

Village South Specific Plan (Proposed) - Los Angeles-South Coast County, Winter

3.6 Paving - 2024

Unmitigated Construction Off-Site

	ROG	NOx	CO	SO2	Fugitive PM10	Exhaust PM10	PM10 Total	Fugitive PM2.5	Exhaust PM2.5	PM2.5 Total	Bio- CO2	NBio- CO2	Total CO2	CH4	N2O	CO2e
Category	lb/day										lb/day					
Hauling	0.0000	0.0000	0.0000	0.0000	0.0000	0.0000	0.0000	0.0000	0.0000	0.0000		0.0000	0.0000	0.0000		0.0000
Vendor	0.0000	0.0000	0.0000	0.0000	0.0000	0.0000	0.0000	0.0000	0.0000	0.0000		0.0000	0.0000	0.0000		0.0000
Worker	0.0601	0.0364	0.4354	1.4500e-003	0.1677	1.2600e-003	0.1689	0.0445	1.1600e-003	0.0456		144.8706	144.8706	3.5300e-003		144.9587
Total	0.0601	0.0364	0.4354	1.4500e-003	0.1677	1.2600e-003	0.1689	0.0445	1.1600e-003	0.0456		144.8706	144.8706	3.5300e-003		144.9587

Mitigated Construction On-Site

	ROG	NOx	CO	SO2	Fugitive PM10	Exhaust PM10	PM10 Total	Fugitive PM2.5	Exhaust PM2.5	PM2.5 Total	Bio- CO2	NBio- CO2	Total CO2	CH4	N2O	CO2e
Category	lb/day										lb/day					
Off-Road	0.9882	9.5246	14.6258	0.0228		0.4685	0.4685		0.4310	0.4310	0.0000	2,207.5472	2,207.5472	0.7140		2,225.3963
Paving	0.0000					0.0000	0.0000		0.0000	0.0000			0.0000			0.0000
Total	0.9882	9.5246	14.6258	0.0228		0.4685	0.4685		0.4310	0.4310	0.0000	2,207.5472	2,207.5472	0.7140		2,225.3963

Village South Specific Plan (Proposed) - Los Angeles-South Coast County, Winter

3.6 Paving - 2024

Mitigated Construction Off-Site

	ROG	NOx	CO	SO2	Fugitive PM10	Exhaust PM10	PM10 Total	Fugitive PM2.5	Exhaust PM2.5	PM2.5 Total	Bio- CO2	NBio- CO2	Total CO2	CH4	N2O	CO2e
Category	lb/day										lb/day					
Hauling	0.0000	0.0000	0.0000	0.0000	0.0000	0.0000	0.0000	0.0000	0.0000	0.0000		0.0000	0.0000	0.0000		0.0000
Vendor	0.0000	0.0000	0.0000	0.0000	0.0000	0.0000	0.0000	0.0000	0.0000	0.0000		0.0000	0.0000	0.0000		0.0000
Worker	0.0601	0.0364	0.4354	1.4500e-003	0.1677	1.2600e-003	0.1689	0.0445	1.1600e-003	0.0456		144.8706	144.8706	3.5300e-003		144.9587
Total	0.0601	0.0364	0.4354	1.4500e-003	0.1677	1.2600e-003	0.1689	0.0445	1.1600e-003	0.0456		144.8706	144.8706	3.5300e-003		144.9587

3.7 Architectural Coating - 2024

Unmitigated Construction On-Site

	ROG	NOx	CO	SO2	Fugitive PM10	Exhaust PM10	PM10 Total	Fugitive PM2.5	Exhaust PM2.5	PM2.5 Total	Bio- CO2	NBio- CO2	Total CO2	CH4	N2O	CO2e
Category	lb/day										lb/day					
Archit. Coating	236.4115					0.0000	0.0000		0.0000	0.0000			0.0000			0.0000
Off-Road	0.1808	1.2188	1.8101	2.9700e-003		0.0609	0.0609		0.0609	0.0609		281.4481	281.4481	0.0159		281.8443
Total	236.5923	1.2188	1.8101	2.9700e-003		0.0609	0.0609		0.0609	0.0609		281.4481	281.4481	0.0159		281.8443

Village South Specific Plan (Proposed) - Los Angeles-South Coast County, Winter

3.7 Architectural Coating - 2024

Unmitigated Construction Off-Site

	ROG	NOx	CO	SO2	Fugitive PM10	Exhaust PM10	PM10 Total	Fugitive PM2.5	Exhaust PM2.5	PM2.5 Total	Bio- CO2	NBio- CO2	Total CO2	CH4	N2O	CO2e
Category	lb/day										lb/day					
Hauling	0.0000	0.0000	0.0000	0.0000	0.0000	0.0000	0.0000	0.0000	0.0000	0.0000		0.0000	0.0000	0.0000		0.0000
Vendor	0.0000	0.0000	0.0000	0.0000	0.0000	0.0000	0.0000	0.0000	0.0000	0.0000		0.0000	0.0000	0.0000		0.0000
Worker	0.6406	0.3886	4.6439	0.0155	1.7884	0.0134	1.8018	0.4743	0.0123	0.4866		1,545.2860	1,545.2860	0.0376		1,546.2262
Total	0.6406	0.3886	4.6439	0.0155	1.7884	0.0134	1.8018	0.4743	0.0123	0.4866		1,545.2860	1,545.2860	0.0376		1,546.2262

Mitigated Construction On-Site

	ROG	NOx	CO	SO2	Fugitive PM10	Exhaust PM10	PM10 Total	Fugitive PM2.5	Exhaust PM2.5	PM2.5 Total	Bio- CO2	NBio- CO2	Total CO2	CH4	N2O	CO2e
Category	lb/day										lb/day					
Archit. Coating	236.4115					0.0000	0.0000		0.0000	0.0000			0.0000			0.0000
Off-Road	0.1808	1.2188	1.8101	2.9700e-003		0.0609	0.0609		0.0609	0.0609	0.0000	281.4481	281.4481	0.0159		281.8443
Total	236.5923	1.2188	1.8101	2.9700e-003		0.0609	0.0609		0.0609	0.0609	0.0000	281.4481	281.4481	0.0159		281.8443

Village South Specific Plan (Proposed) - Los Angeles-South Coast County, Winter

3.7 Architectural Coating - 2024

Mitigated Construction Off-Site

	ROG	NOx	CO	SO2	Fugitive PM10	Exhaust PM10	PM10 Total	Fugitive PM2.5	Exhaust PM2.5	PM2.5 Total	Bio- CO2	NBio- CO2	Total CO2	CH4	N2O	CO2e
Category	lb/day										lb/day					
Hauling	0.0000	0.0000	0.0000	0.0000	0.0000	0.0000	0.0000	0.0000	0.0000	0.0000		0.0000	0.0000	0.0000		0.0000
Vendor	0.0000	0.0000	0.0000	0.0000	0.0000	0.0000	0.0000	0.0000	0.0000	0.0000		0.0000	0.0000	0.0000		0.0000
Worker	0.6406	0.3886	4.6439	0.0155	1.7884	0.0134	1.8018	0.4743	0.0123	0.4866		1,545.2860	1,545.2860	0.0376		1,546.2262
Total	0.6406	0.3886	4.6439	0.0155	1.7884	0.0134	1.8018	0.4743	0.0123	0.4866		1,545.2860	1,545.2860	0.0376		1,546.2262

4.0 Operational Detail - Mobile

4.1 Mitigation Measures Mobile

Village South Specific Plan (Proposed) - Los Angeles-South Coast County, Winter

	ROG	NOx	CO	SO2	Fugitive PM10	Exhaust PM10	PM10 Total	Fugitive PM2.5	Exhaust PM2.5	PM2.5 Total	Bio- CO2	NBio- CO2	Total CO2	CH4	N2O	CO2e
Category	lb/day										lb/day					
Mitigated	9.5233	45.9914	110.0422	0.4681	45.9592	0.3373	46.2965	12.2950	0.3132	12.6083		47,917.8005	47,917.8005	2.1953		47,972.6839
Unmitigated	9.5233	45.9914	110.0422	0.4681	45.9592	0.3373	46.2965	12.2950	0.3132	12.6083		47,917.8005	47,917.8005	2.1953		47,972.6839

4.2 Trip Summary Information

Land Use	Average Daily Trip Rate			Unmitigated	Mitigated
	Weekday	Saturday	Sunday	Annual VMT	Annual VMT
Apartments Low Rise	145.75	154.25	154.00	506,227	506,227
Apartments Mid Rise	4,026.75	3,773.25	4075.50	13,660,065	13,660,065
General Office Building	288.45	62.55	31.05	706,812	706,812
High Turnover (Sit Down Restaurant)	2,368.80	2,873.52	2817.72	3,413,937	3,413,937
Hotel	192.00	187.50	160.00	445,703	445,703
Quality Restaurant	501.12	511.92	461.20	707,488	707,488
Regional Shopping Center	528.08	601.44	357.84	1,112,221	1,112,221
Total	8,050.95	8,164.43	8,057.31	20,552,452	20,552,452

4.3 Trip Type Information

Village South Specific Plan (Proposed) - Los Angeles-South Coast County, Winter

Land Use	Miles			Trip %			Trip Purpose %		
	H-W or C-W	H-S or C-C	H-O or C-NW	H-W or C-W	H-S or C-C	H-O or C-NW	Primary	Diverted	Pass-by
Apartments Low Rise	14.70	5.90	8.70	40.20	19.20	40.60	86	11	3
Apartments Mid Rise	14.70	5.90	8.70	40.20	19.20	40.60	86	11	3
General Office Building	16.60	8.40	6.90	33.00	48.00	19.00	77	19	4
High Turnover (Sit Down Restaurant)	16.60	8.40	6.90	8.50	72.50	19.00	37	20	43
Hotel	16.60	8.40	6.90	19.40	61.60	19.00	58	38	4
Quality Restaurant	16.60	8.40	6.90	12.00	69.00	19.00	38	18	44
Regional Shopping Center	16.60	8.40	6.90	16.30	64.70	19.00	54	35	11

4.4 Fleet Mix

Land Use	LDA	LDT1	LDT2	MDV	LHD1	LHD2	MHD	HHD	OBUS	UBUS	MCY	SBUS	MH
Apartments Low Rise	0.543088	0.044216	0.209971	0.116369	0.014033	0.006332	0.021166	0.033577	0.002613	0.001817	0.005285	0.000712	0.000821
Apartments Mid Rise	0.543088	0.044216	0.209971	0.116369	0.014033	0.006332	0.021166	0.033577	0.002613	0.001817	0.005285	0.000712	0.000821
General Office Building	0.543088	0.044216	0.209971	0.116369	0.014033	0.006332	0.021166	0.033577	0.002613	0.001817	0.005285	0.000712	0.000821
High Turnover (Sit Down Restaurant)	0.543088	0.044216	0.209971	0.116369	0.014033	0.006332	0.021166	0.033577	0.002613	0.001817	0.005285	0.000712	0.000821
Hotel	0.543088	0.044216	0.209971	0.116369	0.014033	0.006332	0.021166	0.033577	0.002613	0.001817	0.005285	0.000712	0.000821
Quality Restaurant	0.543088	0.044216	0.209971	0.116369	0.014033	0.006332	0.021166	0.033577	0.002613	0.001817	0.005285	0.000712	0.000821
Regional Shopping Center	0.543088	0.044216	0.209971	0.116369	0.014033	0.006332	0.021166	0.033577	0.002613	0.001817	0.005285	0.000712	0.000821

5.0 Energy Detail

Historical Energy Use: N

5.1 Mitigation Measures Energy

Village South Specific Plan (Proposed) - Los Angeles-South Coast County, Winter

	ROG	NOx	CO	SO2	Fugitive PM10	Exhaust PM10	PM10 Total	Fugitive PM2.5	Exhaust PM2.5	PM2.5 Total	Bio- CO2	NBio- CO2	Total CO2	CH4	N2O	CO2e
Category	lb/day										lb/day					
NaturalGas Mitigated	0.7660	6.7462	4.2573	0.0418		0.5292	0.5292		0.5292	0.5292		8,355.983 2	8,355.983 2	0.1602	0.1532	8,405.638 7
NaturalGas Unmitigated	0.7660	6.7462	4.2573	0.0418		0.5292	0.5292		0.5292	0.5292		8,355.983 2	8,355.983 2	0.1602	0.1532	8,405.638 7

Village South Specific Plan (Proposed) - Los Angeles-South Coast County, Winter

5.2 Energy by Land Use - NaturalGas

Unmitigated

	NaturalGas Use	ROG	NOx	CO	SO2	Fugitive PM10	Exhaust PM10	PM10 Total	Fugitive PM2.5	Exhaust PM2.5	PM2.5 Total	Bio- CO2	NBio- CO2	Total CO2	CH4	N2O	CO2e
Land Use	kBTU/yr	lb/day										lb/day					
Apartments Low Rise	1119.16	0.0121	0.1031	0.0439	6.6000e-004		8.3400e-003	8.3400e-003		8.3400e-003	8.3400e-003		131.6662	131.6662	2.5200e-003	2.4100e-003	132.4486
Apartments Mid Rise	35784.3	0.3859	3.2978	1.4033	0.0211		0.2666	0.2666		0.2666	0.2666		4,209.9164	4,209.9164	0.0807	0.0772	4,234.9339
General Office Building	1283.42	0.0138	0.1258	0.1057	7.5000e-004		9.5600e-003	9.5600e-003		9.5600e-003	9.5600e-003		150.9911	150.9911	2.8900e-003	2.7700e-003	151.8884
High Turnover (Sit Down Restaurant)	22759.9	0.2455	2.2314	1.8743	0.0134		0.1696	0.1696		0.1696	0.1696		2,677.6342	2,677.6342	0.0513	0.0491	2,693.5460
Hotel	4769.72	0.0514	0.4676	0.3928	2.8100e-003		0.0355	0.0355		0.0355	0.0355		561.1436	561.1436	0.0108	0.0103	564.4782
Quality Restaurant	5057.75	0.0545	0.4959	0.4165	2.9800e-003		0.0377	0.0377		0.0377	0.0377		595.0298	595.0298	0.0114	0.0109	598.5658
Regional Shopping Center	251.616	2.7100e-003	0.0247	0.0207	1.5000e-004		1.8700e-003	1.8700e-003		1.8700e-003	1.8700e-003		29.6019	29.6019	5.7000e-004	5.4000e-004	29.7778
Total		0.7660	6.7463	4.2573	0.0418		0.5292	0.5292		0.5292	0.5292		8,355.9832	8,355.9832	0.1602	0.1532	8,405.6387

Village South Specific Plan (Proposed) - Los Angeles-South Coast County, Winter

5.2 Energy by Land Use - NaturalGas

Mitigated

	NaturalGas Use	ROG	NOx	CO	SO2	Fugitive PM10	Exhaust PM10	PM10 Total	Fugitive PM2.5	Exhaust PM2.5	PM2.5 Total	Bio- CO2	NBio- CO2	Total CO2	CH4	N2O	CO2e
Land Use	kBTU/yr	lb/day										lb/day					
Apartments Low Rise	1.11916	0.0121	0.1031	0.0439	6.6000e-004		8.3400e-003	8.3400e-003		8.3400e-003	8.3400e-003		131.6662	131.6662	2.5200e-003	2.4100e-003	132.4486
Apartments Mid Rise	35.7843	0.3859	3.2978	1.4033	0.0211		0.2666	0.2666		0.2666	0.2666		4,209.9164	4,209.9164	0.0807	0.0772	4,234.9339
General Office Building	1.28342	0.0138	0.1258	0.1057	7.5000e-004		9.5600e-003	9.5600e-003		9.5600e-003	9.5600e-003		150.9911	150.9911	2.8900e-003	2.7700e-003	151.8884
High Turnover (Sit Down Restaurant)	22.7599	0.2455	2.2314	1.8743	0.0134		0.1696	0.1696		0.1696	0.1696		2,677.6342	2,677.6342	0.0513	0.0491	2,693.5460
Hotel	4.76972	0.0514	0.4676	0.3928	2.8100e-003		0.0355	0.0355		0.0355	0.0355		561.1436	561.1436	0.0108	0.0103	564.4782
Quality Restaurant	5.05775	0.0545	0.4959	0.4165	2.9800e-003		0.0377	0.0377		0.0377	0.0377		595.0298	595.0298	0.0114	0.0109	598.5658
Regional Shopping Center	0.251616	2.7100e-003	0.0247	0.0207	1.5000e-004		1.8700e-003	1.8700e-003		1.8700e-003	1.8700e-003		29.6019	29.6019	5.7000e-004	5.4000e-004	29.7778
Total		0.7660	6.7463	4.2573	0.0418		0.5292	0.5292		0.5292	0.5292		8,355.9832	8,355.9832	0.1602	0.1532	8,405.6387

6.0 Area Detail

6.1 Mitigation Measures Area

Village South Specific Plan (Proposed) - Los Angeles-South Coast County, Winter

	ROG	NOx	CO	SO2	Fugitive PM10	Exhaust PM10	PM10 Total	Fugitive PM2.5	Exhaust PM2.5	PM2.5 Total	Bio- CO2	NBio- CO2	Total CO2	CH4	N2O	CO2e
Category	lb/day										lb/day					
Mitigated	30.5020	15.0496	88.4430	0.0944		1.5974	1.5974		1.5974	1.5974	0.0000	18,148.5950	18,148.5950	0.4874	0.3300	18,259.1192
Unmitigated	30.5020	15.0496	88.4430	0.0944		1.5974	1.5974		1.5974	1.5974	0.0000	18,148.5950	18,148.5950	0.4874	0.3300	18,259.1192

6.2 Area by SubCategory

Unmitigated

	ROG	NOx	CO	SO2	Fugitive PM10	Exhaust PM10	PM10 Total	Fugitive PM2.5	Exhaust PM2.5	PM2.5 Total	Bio- CO2	NBio- CO2	Total CO2	CH4	N2O	CO2e
SubCategory	lb/day										lb/day					
Architectural Coating	2.2670					0.0000	0.0000		0.0000	0.0000			0.0000			0.0000
Consumer Products	24.1085					0.0000	0.0000		0.0000	0.0000			0.0000			0.0000
Hearth	1.6500	14.1000	6.0000	0.0900		1.1400	1.1400		1.1400	1.1400	0.0000	18,000.0000	18,000.0000	0.3450	0.3300	18,106.9650
Landscaping	2.4766	0.9496	82.4430	4.3600e-003		0.4574	0.4574		0.4574	0.4574		148.5950	148.5950	0.1424		152.1542
Total	30.5020	15.0496	88.4430	0.0944		1.5974	1.5974		1.5974	1.5974	0.0000	18,148.5950	18,148.5950	0.4874	0.3300	18,259.1192

Village South Specific Plan (Proposed) - Los Angeles-South Coast County, Winter

6.2 Area by SubCategory

Mitigated

	ROG	NOx	CO	SO2	Fugitive PM10	Exhaust PM10	PM10 Total	Fugitive PM2.5	Exhaust PM2.5	PM2.5 Total	Bio- CO2	NBio- CO2	Total CO2	CH4	N2O	CO2e
SubCategory	lb/day										lb/day					
Architectural Coating	2.2670					0.0000	0.0000		0.0000	0.0000			0.0000			0.0000
Consumer Products	24.1085					0.0000	0.0000		0.0000	0.0000			0.0000			0.0000
Hearth	1.6500	14.1000	6.0000	0.0900		1.1400	1.1400		1.1400	1.1400	0.0000	18,000.0000	18,000.0000	0.3450	0.3300	18,106.9650
Landscaping	2.4766	0.9496	82.4430	4.3600e-003		0.4574	0.4574		0.4574	0.4574		148.5950	148.5950	0.1424		152.1542
Total	30.5020	15.0496	88.4430	0.0944		1.5974	1.5974		1.5974	1.5974	0.0000	18,148.5950	18,148.5950	0.4874	0.3300	18,259.1192

7.0 Water Detail

7.1 Mitigation Measures Water

8.0 Waste Detail

8.1 Mitigation Measures Waste

9.0 Operational Offroad

Equipment Type	Number	Hours/Day	Days/Year	Horse Power	Load Factor	Fuel Type
----------------	--------	-----------	-----------	-------------	-------------	-----------

10.0 Stationary Equipment

Village South Specific Plan (Proposed) - Los Angeles-South Coast County, Winter

Fire Pumps and Emergency Generators

Equipment Type	Number	Hours/Day	Hours/Year	Horse Power	Load Factor	Fuel Type
----------------	--------	-----------	------------	-------------	-------------	-----------

Boilers

Equipment Type	Number	Heat Input/Day	Heat Input/Year	Boiler Rating	Fuel Type
----------------	--------	----------------	-----------------	---------------	-----------

User Defined Equipment

Equipment Type	Number
----------------	--------

11.0 Vegetation

Village South Specific Plan (Proposed) - Los Angeles-South Coast County, Annual

Village South Specific Plan (Proposed)
Los Angeles-South Coast County, Annual

1.0 Project Characteristics

1.1 Land Usage

Land Uses	Size	Metric	Lot Acreage	Floor Surface Area	Population
General Office Building	45.00	1000sqft	1.03	45,000.00	0
High Turnover (Sit Down Restaurant)	36.00	1000sqft	0.83	36,000.00	0
Hotel	50.00	Room	1.67	72,600.00	0
Quality Restaurant	8.00	1000sqft	0.18	8,000.00	0
Apartments Low Rise	25.00	Dwelling Unit	1.56	25,000.00	72
Apartments Mid Rise	975.00	Dwelling Unit	25.66	975,000.00	2789
Regional Shopping Center	56.00	1000sqft	1.29	56,000.00	0

1.2 Other Project Characteristics

Urbanization	Urban	Wind Speed (m/s)	2.2	Precipitation Freq (Days)	33
Climate Zone	9			Operational Year	2028
Utility Company	Southern California Edison				
CO2 Intensity (lb/MW hr)	702.44	CH4 Intensity (lb/MW hr)	0.029	N2O Intensity (lb/MW hr)	0.006

1.3 User Entered Comments & Non-Default Data

Village South Specific Plan (Proposed) - Los Angeles-South Coast County, Annual

Project Characteristics - Consistent with the DEIR's model.

Land Use - See SWAPE comment regarding residential and retail land uses.

Construction Phase - See SWAPE comment regarding individual construction phase lengths.

Demolition - Consistent with the DEIR's model. See SWAPE comment regarding demolition.

Vehicle Trips - Saturday trips consistent with the DEIR's model. See SWAPE comment regarding weekday and Sunday trips.

Woodstoves - Woodstoves and wood-burning fireplaces consistent with the DEIR's model. See SWAPE comment regarding gas fireplaces.

Energy Use -

Construction Off-road Equipment Mitigation - See SWAPE comment on construction-related mitigation.

Area Mitigation - See SWAPE comment regarding operational mitigation measures.

Water Mitigation - See SWAPE comment regarding operational mitigation measures.

Trips and VMT - Local hire provision

Table Name	Column Name	Default Value	New Value
tblFireplaces	FireplaceWoodMass	1,019.20	0.00
tblFireplaces	FireplaceWoodMass	1,019.20	0.00
tblFireplaces	NumberWood	1.25	0.00
tblFireplaces	NumberWood	48.75	0.00
tblTripsAndVMT	WorkerTripLength	14.70	10.00
tblTripsAndVMT	WorkerTripLength	14.70	10.00
tblTripsAndVMT	WorkerTripLength	14.70	10.00
tblTripsAndVMT	WorkerTripLength	14.70	10.00
tblTripsAndVMT	WorkerTripLength	14.70	10.00
tblTripsAndVMT	WorkerTripLength	14.70	10.00
tblVehicleTrips	ST_TR	7.16	6.17
tblVehicleTrips	ST_TR	6.39	3.87
tblVehicleTrips	ST_TR	2.46	1.39
tblVehicleTrips	ST_TR	158.37	79.82

Village South Specific Plan (Proposed) - Los Angeles-South Coast County, Annual

tblVehicleTrips	ST_TR	8.19	3.75
tblVehicleTrips	ST_TR	94.36	63.99
tblVehicleTrips	ST_TR	49.97	10.74
tblVehicleTrips	SU_TR	6.07	6.16
tblVehicleTrips	SU_TR	5.86	4.18
tblVehicleTrips	SU_TR	1.05	0.69
tblVehicleTrips	SU_TR	131.84	78.27
tblVehicleTrips	SU_TR	5.95	3.20
tblVehicleTrips	SU_TR	72.16	57.65
tblVehicleTrips	SU_TR	25.24	6.39
tblVehicleTrips	WD_TR	6.59	5.83
tblVehicleTrips	WD_TR	6.65	4.13
tblVehicleTrips	WD_TR	11.03	6.41
tblVehicleTrips	WD_TR	127.15	65.80
tblVehicleTrips	WD_TR	8.17	3.84
tblVehicleTrips	WD_TR	89.95	62.64
tblVehicleTrips	WD_TR	42.70	9.43
tblWoodstoves	NumberCatalytic	1.25	0.00
tblWoodstoves	NumberCatalytic	48.75	0.00
tblWoodstoves	NumberNoncatalytic	1.25	0.00
tblWoodstoves	NumberNoncatalytic	48.75	0.00
tblWoodstoves	WoodstoveDayYear	25.00	0.00
tblWoodstoves	WoodstoveDayYear	25.00	0.00
tblWoodstoves	WoodstoveWoodMass	999.60	0.00
tblWoodstoves	WoodstoveWoodMass	999.60	0.00

2.0 Emissions Summary

Village South Specific Plan (Proposed) - Los Angeles-South Coast County, Annual

2.1 Overall Construction

Unmitigated Construction

	ROG	NOx	CO	SO2	Fugitive PM10	Exhaust PM10	PM10 Total	Fugitive PM2.5	Exhaust PM2.5	PM2.5 Total	Bio- CO2	NBio- CO2	Total CO2	CH4	N2O	CO2e
Year	tons/yr										MT/yr					
2021	0.1704	1.8234	1.1577	2.3800e-003	0.4141	0.0817	0.4958	0.1788	0.0754	0.2542	0.0000	210.7654	210.7654	0.0600	0.0000	212.2661
2022	0.5865	4.0240	5.1546	0.0155	0.9509	0.1175	1.0683	0.2518	0.1103	0.3621	0.0000	1,418.6554	1,418.6554	0.1215	0.0000	1,421.6925
2023	0.5190	3.2850	4.7678	0.0147	0.8497	0.0971	0.9468	0.2283	0.0912	0.3195	0.0000	1,342.4412	1,342.4412	0.1115	0.0000	1,345.2291
2024	4.1592	0.1313	0.2557	5.0000e-004	0.0221	6.3900e-003	0.0285	5.8700e-003	5.9700e-003	0.0118	0.0000	44.6355	44.6355	7.8300e-003	0.0000	44.8311
Maximum	4.1592	4.0240	5.1546	0.0155	0.9509	0.1175	1.0683	0.2518	0.1103	0.3621	0.0000	1,418.6554	1,418.6554	0.1215	0.0000	1,421.6925

Village South Specific Plan (Proposed) - Los Angeles-South Coast County, Annual

2.1 Overall Construction

Mitigated Construction

	ROG	NOx	CO	SO2	Fugitive PM10	Exhaust PM10	PM10 Total	Fugitive PM2.5	Exhaust PM2.5	PM2.5 Total	Bio- CO2	NBio- CO2	Total CO2	CH4	N2O	CO2e
Year	tons/yr										MT/yr					
2021	0.1704	1.8234	1.1577	2.3800e-003	0.4141	0.0817	0.4958	0.1788	0.0754	0.2542	0.0000	210.7651	210.7651	0.0600	0.0000	212.2658
2022	0.5865	4.0240	5.1546	0.0155	0.9509	0.1175	1.0683	0.2518	0.1103	0.3621	0.0000	1,418.6550	1,418.6550	0.1215	0.0000	1,421.6921
2023	0.5190	3.2850	4.7678	0.0147	0.8497	0.0971	0.9468	0.2283	0.0912	0.3195	0.0000	1,342.4409	1,342.4409	0.1115	0.0000	1,345.2287
2024	4.1592	0.1313	0.2557	5.0000e-004	0.0221	6.3900e-003	0.0285	5.8700e-003	5.9700e-003	0.0118	0.0000	44.6354	44.6354	7.8300e-003	0.0000	44.8311
Maximum	4.1592	4.0240	5.1546	0.0155	0.9509	0.1175	1.0683	0.2518	0.1103	0.3621	0.0000	1,418.6550	1,418.6550	0.1215	0.0000	1,421.6921

	ROG	NOx	CO	SO2	Fugitive PM10	Exhaust PM10	PM10 Total	Fugitive PM2.5	Exhaust PM2.5	PM2.5 Total	Bio- CO2	NBio- CO2	Total CO2	CH4	N2O	CO2e
Percent Reduction	0.00	0.00	0.00	0.00	0.00	0.00	0.00	0.00	0.00	0.00	0.00	0.00	0.00	0.00	0.00	0.00

Quarter	Start Date	End Date	Maximum Unmitigated ROG + NOX (tons/quarter)	Maximum Mitigated ROG + NOX (tons/quarter)
1	9-1-2021	11-30-2021	1.4091	1.4091
2	12-1-2021	2-28-2022	1.3329	1.3329
3	3-1-2022	5-31-2022	1.1499	1.1499
4	6-1-2022	8-31-2022	1.1457	1.1457
5	9-1-2022	11-30-2022	1.1415	1.1415
6	12-1-2022	2-28-2023	1.0278	1.0278
7	3-1-2023	5-31-2023	0.9868	0.9868
8	6-1-2023	8-31-2023	0.9831	0.9831

Village South Specific Plan (Proposed) - Los Angeles-South Coast County, Annual

9	9-1-2023	11-30-2023	0.9798	0.9798
10	12-1-2023	2-29-2024	2.8757	2.8757
11	3-1-2024	5-31-2024	1.6188	1.6188
		Highest	2.8757	2.8757

2.2 Overall Operational
Unmitigated Operational

	ROG	NOx	CO	SO2	Fugitive PM10	Exhaust PM10	PM10 Total	Fugitive PM2.5	Exhaust PM2.5	PM2.5 Total	Bio- CO2	NBio- CO2	Total CO2	CH4	N2O	CO2e
Category	tons/yr										MT/yr					
Area	5.1437	0.2950	10.3804	1.6700e-003		0.0714	0.0714		0.0714	0.0714	0.0000	220.9670	220.9670	0.0201	3.7400e-003	222.5835
Energy	0.1398	1.2312	0.7770	7.6200e-003		0.0966	0.0966		0.0966	0.0966	0.0000	3,896.0732	3,896.0732	0.1303	0.0468	3,913.2833
Mobile	1.5857	7.9962	19.1834	0.0821	7.7979	0.0580	7.8559	2.0895	0.0539	2.1434	0.0000	7,620.4986	7,620.4986	0.3407	0.0000	7,629.0162
Waste						0.0000	0.0000		0.0000	0.0000	207.8079	0.0000	207.8079	12.2811	0.0000	514.8354
Water						0.0000	0.0000		0.0000	0.0000	29.1632	556.6420	585.8052	3.0183	0.0755	683.7567
Total	6.8692	9.5223	30.3407	0.0914	7.7979	0.2260	8.0240	2.0895	0.2219	2.3114	236.9712	12,294.1807	12,531.1519	15.7904	0.1260	12,963.4751

Village South Specific Plan (Proposed) - Los Angeles-South Coast County, Annual

2.2 Overall Operational

Mitigated Operational

	ROG	NOx	CO	SO2	Fugitive PM10	Exhaust PM10	PM10 Total	Fugitive PM2.5	Exhaust PM2.5	PM2.5 Total	Bio- CO2	NBio- CO2	Total CO2	CH4	N2O	CO2e
Category	tons/yr										MT/yr					
Area	5.1437	0.2950	10.3804	1.6700e-003		0.0714	0.0714		0.0714	0.0714	0.0000	220.9670	220.9670	0.0201	3.7400e-003	222.5835
Energy	0.1398	1.2312	0.7770	7.6200e-003		0.0966	0.0966		0.0966	0.0966	0.0000	3,896.0732	3,896.0732	0.1303	0.0468	3,913.2833
Mobile	1.5857	7.9962	19.1834	0.0821	7.7979	0.0580	7.8559	2.0895	0.0539	2.1434	0.0000	7,620.4986	7,620.4986	0.3407	0.0000	7,629.0162
Waste						0.0000	0.0000		0.0000	0.0000	207.8079	0.0000	207.8079	12.2811	0.0000	514.8354
Water						0.0000	0.0000		0.0000	0.0000	29.1632	556.6420	585.8052	3.0183	0.0755	683.7567
Total	6.8692	9.5223	30.3407	0.0914	7.7979	0.2260	8.0240	2.0895	0.2219	2.3114	236.9712	12,294.1807	12,531.1519	15.7904	0.1260	12,963.4751

	ROG	NOx	CO	SO2	Fugitive PM10	Exhaust PM10	PM10 Total	Fugitive PM2.5	Exhaust PM2.5	PM2.5 Total	Bio- CO2	NBio- CO2	Total CO2	CH4	N2O	CO2e
Percent Reduction	0.00	0.00	0.00	0.00	0.00	0.00	0.00	0.00	0.00	0.00	0.00	0.00	0.00	0.00	0.00	0.00

3.0 Construction Detail

Construction Phase

Village South Specific Plan (Proposed) - Los Angeles-South Coast County, Annual

Phase Number	Phase Name	Phase Type	Start Date	End Date	Num Days Week	Num Days	Phase Description
1	Demolition	Demolition	9/1/2021	10/12/2021	5	30	
2	Site Preparation	Site Preparation	10/13/2021	11/9/2021	5	20	
3	Grading	Grading	11/10/2021	1/11/2022	5	45	
4	Building Construction	Building Construction	1/12/2022	12/12/2023	5	500	
5	Paving	Paving	12/13/2023	1/30/2024	5	35	
6	Architectural Coating	Architectural Coating	1/31/2024	3/19/2024	5	35	

Acres of Grading (Site Preparation Phase): 0

Acres of Grading (Grading Phase): 112.5

Acres of Paving: 0

Residential Indoor: 2,025,000; Residential Outdoor: 675,000; Non-Residential Indoor: 326,400; Non-Residential Outdoor: 108,800; Striped Parking Area: 0 (Architectural Coating – sqft)

OffRoad Equipment

Village South Specific Plan (Proposed) - Los Angeles-South Coast County, Annual

Phase Name	Offroad Equipment Type	Amount	Usage Hours	Horse Power	Load Factor
Demolition	Concrete/Industrial Saws	1	8.00	81	0.73
Demolition	Excavators	3	8.00	158	0.38
Demolition	Rubber Tired Dozers	2	8.00	247	0.40
Site Preparation	Rubber Tired Dozers	3	8.00	247	0.40
Site Preparation	Tractors/Loaders/Backhoes	4	8.00	97	0.37
Grading	Excavators	2	8.00	158	0.38
Grading	Graders	1	8.00	187	0.41
Grading	Rubber Tired Dozers	1	8.00	247	0.40
Grading	Scrapers	2	8.00	367	0.48
Grading	Tractors/Loaders/Backhoes	2	8.00	97	0.37
Building Construction	Cranes	1	7.00	231	0.29
Building Construction	Forklifts	3	8.00	89	0.20
Building Construction	Generator Sets	1	8.00	84	0.74
Building Construction	Tractors/Loaders/Backhoes	3	7.00	97	0.37
Building Construction	Welders	1	8.00	46	0.45
Paving	Pavers	2	8.00	130	0.42
Paving	Paving Equipment	2	8.00	132	0.36
Paving	Rollers	2	8.00	80	0.38
Architectural Coating	Air Compressors	1	6.00	78	0.48

Trips and VMT

Village South Specific Plan (Proposed) - Los Angeles-South Coast County, Annual

Phase Name	Offroad Equipment Count	Worker Trip Number	Vendor Trip Number	Hauling Trip Number	Worker Trip Length	Vendor Trip Length	Hauling Trip Length	Worker Vehicle Class	Vendor Vehicle Class	Hauling Vehicle Class
Demolition	6	15.00	0.00	458.00	10.00	6.90	20.00	LD_Mix	HDT_Mix	HHDT
Site Preparation	7	18.00	0.00	0.00	10.00	6.90	20.00	LD_Mix	HDT_Mix	HHDT
Grading	8	20.00	0.00	0.00	10.00	6.90	20.00	LD_Mix	HDT_Mix	HHDT
Building Construction	9	801.00	143.00	0.00	10.00	6.90	20.00	LD_Mix	HDT_Mix	HHDT
Paving	6	15.00	0.00	0.00	10.00	6.90	20.00	LD_Mix	HDT_Mix	HHDT
Architectural Coating	1	160.00	0.00	0.00	10.00	6.90	20.00	LD_Mix	HDT_Mix	HHDT

3.1 Mitigation Measures Construction

3.2 Demolition - 2021

Unmitigated Construction On-Site

	ROG	NOx	CO	SO2	Fugitive PM10	Exhaust PM10	PM10 Total	Fugitive PM2.5	Exhaust PM2.5	PM2.5 Total	Bio- CO2	NBio- CO2	Total CO2	CH4	N2O	CO2e
Category	tons/yr										MT/yr					
Fugitive Dust					0.0496	0.0000	0.0496	7.5100e-003	0.0000	7.5100e-003	0.0000	0.0000	0.0000	0.0000	0.0000	0.0000
Off-Road	0.0475	0.4716	0.3235	5.8000e-004		0.0233	0.0233		0.0216	0.0216	0.0000	51.0012	51.0012	0.0144	0.0000	51.3601
Total	0.0475	0.4716	0.3235	5.8000e-004	0.0496	0.0233	0.0729	7.5100e-003	0.0216	0.0291	0.0000	51.0012	51.0012	0.0144	0.0000	51.3601

Village South Specific Plan (Proposed) - Los Angeles-South Coast County, Annual

3.2 Demolition - 2021

Unmitigated Construction Off-Site

	ROG	NOx	CO	SO2	Fugitive PM10	Exhaust PM10	PM10 Total	Fugitive PM2.5	Exhaust PM2.5	PM2.5 Total	Bio- CO2	NBio- CO2	Total CO2	CH4	N2O	CO2e
Category	tons/yr										MT/yr					
Hauling	1.9300e-003	0.0634	0.0148	1.8000e-004	3.9400e-003	1.9000e-004	4.1300e-003	1.0800e-003	1.8000e-004	1.2600e-003	0.0000	17.4566	17.4566	1.2100e-003	0.0000	17.4869
Vendor	0.0000	0.0000	0.0000	0.0000	0.0000	0.0000	0.0000	0.0000	0.0000	0.0000	0.0000	0.0000	0.0000	0.0000	0.0000	0.0000
Worker	7.2000e-004	5.3000e-004	6.0900e-003	2.0000e-005	1.6800e-003	1.0000e-005	1.6900e-003	4.5000e-004	1.0000e-005	4.6000e-004	0.0000	1.5281	1.5281	5.0000e-005	0.0000	1.5293
Total	2.6500e-003	0.0639	0.0209	2.0000e-004	5.6200e-003	2.0000e-004	5.8200e-003	1.5300e-003	1.9000e-004	1.7200e-003	0.0000	18.9847	18.9847	1.2600e-003	0.0000	19.0161

Mitigated Construction On-Site

	ROG	NOx	CO	SO2	Fugitive PM10	Exhaust PM10	PM10 Total	Fugitive PM2.5	Exhaust PM2.5	PM2.5 Total	Bio- CO2	NBio- CO2	Total CO2	CH4	N2O	CO2e
Category	tons/yr										MT/yr					
Fugitive Dust					0.0496	0.0000	0.0496	7.5100e-003	0.0000	7.5100e-003	0.0000	0.0000	0.0000	0.0000	0.0000	0.0000
Off-Road	0.0475	0.4716	0.3235	5.8000e-004		0.0233	0.0233		0.0216	0.0216	0.0000	51.0011	51.0011	0.0144	0.0000	51.3600
Total	0.0475	0.4716	0.3235	5.8000e-004	0.0496	0.0233	0.0729	7.5100e-003	0.0216	0.0291	0.0000	51.0011	51.0011	0.0144	0.0000	51.3600

Village South Specific Plan (Proposed) - Los Angeles-South Coast County, Annual

3.2 Demolition - 2021

Mitigated Construction Off-Site

	ROG	NOx	CO	SO2	Fugitive PM10	Exhaust PM10	PM10 Total	Fugitive PM2.5	Exhaust PM2.5	PM2.5 Total	Bio- CO2	NBio- CO2	Total CO2	CH4	N2O	CO2e
Category	tons/yr										MT/yr					
Hauling	1.9300e-003	0.0634	0.0148	1.8000e-004	3.9400e-003	1.9000e-004	4.1300e-003	1.0800e-003	1.8000e-004	1.2600e-003	0.0000	17.4566	17.4566	1.2100e-003	0.0000	17.4869
Vendor	0.0000	0.0000	0.0000	0.0000	0.0000	0.0000	0.0000	0.0000	0.0000	0.0000	0.0000	0.0000	0.0000	0.0000	0.0000	0.0000
Worker	7.2000e-004	5.3000e-004	6.0900e-003	2.0000e-005	1.6800e-003	1.0000e-005	1.6900e-003	4.5000e-004	1.0000e-005	4.6000e-004	0.0000	1.5281	1.5281	5.0000e-005	0.0000	1.5293
Total	2.6500e-003	0.0639	0.0209	2.0000e-004	5.6200e-003	2.0000e-004	5.8200e-003	1.5300e-003	1.9000e-004	1.7200e-003	0.0000	18.9847	18.9847	1.2600e-003	0.0000	19.0161

3.3 Site Preparation - 2021

Unmitigated Construction On-Site

	ROG	NOx	CO	SO2	Fugitive PM10	Exhaust PM10	PM10 Total	Fugitive PM2.5	Exhaust PM2.5	PM2.5 Total	Bio- CO2	NBio- CO2	Total CO2	CH4	N2O	CO2e
Category	tons/yr										MT/yr					
Fugitive Dust					0.1807	0.0000	0.1807	0.0993	0.0000	0.0993	0.0000	0.0000	0.0000	0.0000	0.0000	0.0000
Off-Road	0.0389	0.4050	0.2115	3.8000e-004		0.0204	0.0204		0.0188	0.0188	0.0000	33.4357	33.4357	0.0108	0.0000	33.7061
Total	0.0389	0.4050	0.2115	3.8000e-004	0.1807	0.0204	0.2011	0.0993	0.0188	0.1181	0.0000	33.4357	33.4357	0.0108	0.0000	33.7061

Village South Specific Plan (Proposed) - Los Angeles-South Coast County, Annual

3.3 Site Preparation - 2021

Unmitigated Construction Off-Site

	ROG	NOx	CO	SO2	Fugitive PM10	Exhaust PM10	PM10 Total	Fugitive PM2.5	Exhaust PM2.5	PM2.5 Total	Bio- CO2	NBio- CO2	Total CO2	CH4	N2O	CO2e
Category	tons/yr										MT/yr					
Hauling	0.0000	0.0000	0.0000	0.0000	0.0000	0.0000	0.0000	0.0000	0.0000	0.0000	0.0000	0.0000	0.0000	0.0000	0.0000	0.0000
Vendor	0.0000	0.0000	0.0000	0.0000	0.0000	0.0000	0.0000	0.0000	0.0000	0.0000	0.0000	0.0000	0.0000	0.0000	0.0000	0.0000
Worker	5.8000e-004	4.3000e-004	4.8700e-003	1.0000e-005	1.3400e-003	1.0000e-005	1.3500e-003	3.6000e-004	1.0000e-005	3.7000e-004	0.0000	1.2225	1.2225	4.0000e-005	0.0000	1.2234
Total	5.8000e-004	4.3000e-004	4.8700e-003	1.0000e-005	1.3400e-003	1.0000e-005	1.3500e-003	3.6000e-004	1.0000e-005	3.7000e-004	0.0000	1.2225	1.2225	4.0000e-005	0.0000	1.2234

Mitigated Construction On-Site

	ROG	NOx	CO	SO2	Fugitive PM10	Exhaust PM10	PM10 Total	Fugitive PM2.5	Exhaust PM2.5	PM2.5 Total	Bio- CO2	NBio- CO2	Total CO2	CH4	N2O	CO2e
Category	tons/yr										MT/yr					
Fugitive Dust					0.1807	0.0000	0.1807	0.0993	0.0000	0.0993	0.0000	0.0000	0.0000	0.0000	0.0000	0.0000
Off-Road	0.0389	0.4050	0.2115	3.8000e-004		0.0204	0.0204		0.0188	0.0188	0.0000	33.4357	33.4357	0.0108	0.0000	33.7060
Total	0.0389	0.4050	0.2115	3.8000e-004	0.1807	0.0204	0.2011	0.0993	0.0188	0.1181	0.0000	33.4357	33.4357	0.0108	0.0000	33.7060

Village South Specific Plan (Proposed) - Los Angeles-South Coast County, Annual

3.3 Site Preparation - 2021

Mitigated Construction Off-Site

	ROG	NOx	CO	SO2	Fugitive PM10	Exhaust PM10	PM10 Total	Fugitive PM2.5	Exhaust PM2.5	PM2.5 Total	Bio- CO2	NBio- CO2	Total CO2	CH4	N2O	CO2e
Category	tons/yr										MT/yr					
Hauling	0.0000	0.0000	0.0000	0.0000	0.0000	0.0000	0.0000	0.0000	0.0000	0.0000	0.0000	0.0000	0.0000	0.0000	0.0000	0.0000
Vendor	0.0000	0.0000	0.0000	0.0000	0.0000	0.0000	0.0000	0.0000	0.0000	0.0000	0.0000	0.0000	0.0000	0.0000	0.0000	0.0000
Worker	5.8000e-004	4.3000e-004	4.8700e-003	1.0000e-005	1.3400e-003	1.0000e-005	1.3500e-003	3.6000e-004	1.0000e-005	3.7000e-004	0.0000	1.2225	1.2225	4.0000e-005	0.0000	1.2234
Total	5.8000e-004	4.3000e-004	4.8700e-003	1.0000e-005	1.3400e-003	1.0000e-005	1.3500e-003	3.6000e-004	1.0000e-005	3.7000e-004	0.0000	1.2225	1.2225	4.0000e-005	0.0000	1.2234

3.4 Grading - 2021

Unmitigated Construction On-Site

	ROG	NOx	CO	SO2	Fugitive PM10	Exhaust PM10	PM10 Total	Fugitive PM2.5	Exhaust PM2.5	PM2.5 Total	Bio- CO2	NBio- CO2	Total CO2	CH4	N2O	CO2e
Category	tons/yr										MT/yr					
Fugitive Dust					0.1741	0.0000	0.1741	0.0693	0.0000	0.0693	0.0000	0.0000	0.0000	0.0000	0.0000	0.0000
Off-Road	0.0796	0.8816	0.5867	1.1800e-003		0.0377	0.0377		0.0347	0.0347	0.0000	103.5405	103.5405	0.0335	0.0000	104.3776
Total	0.0796	0.8816	0.5867	1.1800e-003	0.1741	0.0377	0.2118	0.0693	0.0347	0.1040	0.0000	103.5405	103.5405	0.0335	0.0000	104.3776

Village South Specific Plan (Proposed) - Los Angeles-South Coast County, Annual

3.4 Grading - 2021

Unmitigated Construction Off-Site

	ROG	NOx	CO	SO2	Fugitive PM10	Exhaust PM10	PM10 Total	Fugitive PM2.5	Exhaust PM2.5	PM2.5 Total	Bio- CO2	NBio- CO2	Total CO2	CH4	N2O	CO2e
Category	tons/yr										MT/yr					
Hauling	0.0000	0.0000	0.0000	0.0000	0.0000	0.0000	0.0000	0.0000	0.0000	0.0000	0.0000	0.0000	0.0000	0.0000	0.0000	0.0000
Vendor	0.0000	0.0000	0.0000	0.0000	0.0000	0.0000	0.0000	0.0000	0.0000	0.0000	0.0000	0.0000	0.0000	0.0000	0.0000	0.0000
Worker	1.2200e-003	9.0000e-004	0.0103	3.0000e-005	2.8300e-003	2.0000e-005	2.8600e-003	7.5000e-004	2.0000e-005	7.8000e-004	0.0000	2.5808	2.5808	8.0000e-005	0.0000	2.5828
Total	1.2200e-003	9.0000e-004	0.0103	3.0000e-005	2.8300e-003	2.0000e-005	2.8600e-003	7.5000e-004	2.0000e-005	7.8000e-004	0.0000	2.5808	2.5808	8.0000e-005	0.0000	2.5828

Mitigated Construction On-Site

	ROG	NOx	CO	SO2	Fugitive PM10	Exhaust PM10	PM10 Total	Fugitive PM2.5	Exhaust PM2.5	PM2.5 Total	Bio- CO2	NBio- CO2	Total CO2	CH4	N2O	CO2e
Category	tons/yr										MT/yr					
Fugitive Dust					0.1741	0.0000	0.1741	0.0693	0.0000	0.0693	0.0000	0.0000	0.0000	0.0000	0.0000	0.0000
Off-Road	0.0796	0.8816	0.5867	1.1800e-003		0.0377	0.0377		0.0347	0.0347	0.0000	103.5403	103.5403	0.0335	0.0000	104.3775
Total	0.0796	0.8816	0.5867	1.1800e-003	0.1741	0.0377	0.2118	0.0693	0.0347	0.1040	0.0000	103.5403	103.5403	0.0335	0.0000	104.3775

Village South Specific Plan (Proposed) - Los Angeles-South Coast County, Annual

3.4 Grading - 2021

Mitigated Construction Off-Site

	ROG	NOx	CO	SO2	Fugitive PM10	Exhaust PM10	PM10 Total	Fugitive PM2.5	Exhaust PM2.5	PM2.5 Total	Bio- CO2	NBio- CO2	Total CO2	CH4	N2O	CO2e
Category	tons/yr										MT/yr					
Hauling	0.0000	0.0000	0.0000	0.0000	0.0000	0.0000	0.0000	0.0000	0.0000	0.0000	0.0000	0.0000	0.0000	0.0000	0.0000	0.0000
Vendor	0.0000	0.0000	0.0000	0.0000	0.0000	0.0000	0.0000	0.0000	0.0000	0.0000	0.0000	0.0000	0.0000	0.0000	0.0000	0.0000
Worker	1.2200e-003	9.0000e-004	0.0103	3.0000e-005	2.8300e-003	2.0000e-005	2.8600e-003	7.5000e-004	2.0000e-005	7.8000e-004	0.0000	2.5808	2.5808	8.0000e-005	0.0000	2.5828
Total	1.2200e-003	9.0000e-004	0.0103	3.0000e-005	2.8300e-003	2.0000e-005	2.8600e-003	7.5000e-004	2.0000e-005	7.8000e-004	0.0000	2.5808	2.5808	8.0000e-005	0.0000	2.5828

3.4 Grading - 2022

Unmitigated Construction On-Site

	ROG	NOx	CO	SO2	Fugitive PM10	Exhaust PM10	PM10 Total	Fugitive PM2.5	Exhaust PM2.5	PM2.5 Total	Bio- CO2	NBio- CO2	Total CO2	CH4	N2O	CO2e
Category	tons/yr										MT/yr					
Fugitive Dust					0.0807	0.0000	0.0807	0.0180	0.0000	0.0180	0.0000	0.0000	0.0000	0.0000	0.0000	0.0000
Off-Road	0.0127	0.1360	0.1017	2.2000e-004		5.7200e-003	5.7200e-003		5.2600e-003	5.2600e-003	0.0000	19.0871	19.0871	6.1700e-003	0.0000	19.2414
Total	0.0127	0.1360	0.1017	2.2000e-004	0.0807	5.7200e-003	0.0865	0.0180	5.2600e-003	0.0233	0.0000	19.0871	19.0871	6.1700e-003	0.0000	19.2414

Village South Specific Plan (Proposed) - Los Angeles-South Coast County, Annual

3.4 Grading - 2022

Unmitigated Construction Off-Site

	ROG	NOx	CO	SO2	Fugitive PM10	Exhaust PM10	PM10 Total	Fugitive PM2.5	Exhaust PM2.5	PM2.5 Total	Bio- CO2	NBio- CO2	Total CO2	CH4	N2O	CO2e
Category	tons/yr										MT/yr					
Hauling	0.0000	0.0000	0.0000	0.0000	0.0000	0.0000	0.0000	0.0000	0.0000	0.0000	0.0000	0.0000	0.0000	0.0000	0.0000	0.0000
Vendor	0.0000	0.0000	0.0000	0.0000	0.0000	0.0000	0.0000	0.0000	0.0000	0.0000	0.0000	0.0000	0.0000	0.0000	0.0000	0.0000
Worker	2.1000e-004	1.5000e-004	1.7400e-003	1.0000e-005	5.2000e-004	0.0000	5.3000e-004	1.4000e-004	0.0000	1.4000e-004	0.0000	0.4587	0.4587	1.0000e-005	0.0000	0.4590
Total	2.1000e-004	1.5000e-004	1.7400e-003	1.0000e-005	5.2000e-004	0.0000	5.3000e-004	1.4000e-004	0.0000	1.4000e-004	0.0000	0.4587	0.4587	1.0000e-005	0.0000	0.4590

Mitigated Construction On-Site

	ROG	NOx	CO	SO2	Fugitive PM10	Exhaust PM10	PM10 Total	Fugitive PM2.5	Exhaust PM2.5	PM2.5 Total	Bio- CO2	NBio- CO2	Total CO2	CH4	N2O	CO2e
Category	tons/yr										MT/yr					
Fugitive Dust					0.0807	0.0000	0.0807	0.0180	0.0000	0.0180	0.0000	0.0000	0.0000	0.0000	0.0000	0.0000
Off-Road	0.0127	0.1360	0.1017	2.2000e-004		5.7200e-003	5.7200e-003		5.2600e-003	5.2600e-003	0.0000	19.0871	19.0871	6.1700e-003	0.0000	19.2414
Total	0.0127	0.1360	0.1017	2.2000e-004	0.0807	5.7200e-003	0.0865	0.0180	5.2600e-003	0.0233	0.0000	19.0871	19.0871	6.1700e-003	0.0000	19.2414

Village South Specific Plan (Proposed) - Los Angeles-South Coast County, Annual

3.4 Grading - 2022

Mitigated Construction Off-Site

	ROG	NOx	CO	SO2	Fugitive PM10	Exhaust PM10	PM10 Total	Fugitive PM2.5	Exhaust PM2.5	PM2.5 Total	Bio- CO2	NBio- CO2	Total CO2	CH4	N2O	CO2e
Category	tons/yr										MT/yr					
Hauling	0.0000	0.0000	0.0000	0.0000	0.0000	0.0000	0.0000	0.0000	0.0000	0.0000	0.0000	0.0000	0.0000	0.0000	0.0000	0.0000
Vendor	0.0000	0.0000	0.0000	0.0000	0.0000	0.0000	0.0000	0.0000	0.0000	0.0000	0.0000	0.0000	0.0000	0.0000	0.0000	0.0000
Worker	2.1000e-004	1.5000e-004	1.7400e-003	1.0000e-005	5.2000e-004	0.0000	5.3000e-004	1.4000e-004	0.0000	1.4000e-004	0.0000	0.4587	0.4587	1.0000e-005	0.0000	0.4590
Total	2.1000e-004	1.5000e-004	1.7400e-003	1.0000e-005	5.2000e-004	0.0000	5.3000e-004	1.4000e-004	0.0000	1.4000e-004	0.0000	0.4587	0.4587	1.0000e-005	0.0000	0.4590

3.5 Building Construction - 2022

Unmitigated Construction On-Site

	ROG	NOx	CO	SO2	Fugitive PM10	Exhaust PM10	PM10 Total	Fugitive PM2.5	Exhaust PM2.5	PM2.5 Total	Bio- CO2	NBio- CO2	Total CO2	CH4	N2O	CO2e
Category	tons/yr										MT/yr					
Off-Road	0.2158	1.9754	2.0700	3.4100e-003		0.1023	0.1023		0.0963	0.0963	0.0000	293.1324	293.1324	0.0702	0.0000	294.8881
Total	0.2158	1.9754	2.0700	3.4100e-003		0.1023	0.1023		0.0963	0.0963	0.0000	293.1324	293.1324	0.0702	0.0000	294.8881

Village South Specific Plan (Proposed) - Los Angeles-South Coast County, Annual

3.5 Building Construction - 2022

Unmitigated Construction Off-Site

	ROG	NOx	CO	SO2	Fugitive PM10	Exhaust PM10	PM10 Total	Fugitive PM2.5	Exhaust PM2.5	PM2.5 Total	Bio- CO2	NBio- CO2	Total CO2	CH4	N2O	CO2e
Category	tons/yr										MT/yr					
Hauling	0.0000	0.0000	0.0000	0.0000	0.0000	0.0000	0.0000	0.0000	0.0000	0.0000	0.0000	0.0000	0.0000	0.0000	0.0000	0.0000
Vendor	0.0527	1.6961	0.4580	4.5500e-003	0.1140	3.1800e-003	0.1171	0.0329	3.0400e-003	0.0359	0.0000	441.9835	441.9835	0.0264	0.0000	442.6435
Worker	0.3051	0.2164	2.5233	7.3500e-003	0.7557	6.2300e-003	0.7619	0.2007	5.7400e-003	0.2065	0.0000	663.9936	663.9936	0.0187	0.0000	664.4604
Total	0.3578	1.9125	2.9812	0.0119	0.8696	9.4100e-003	0.8790	0.2336	8.7800e-003	0.2424	0.0000	1,105.9771	1,105.9771	0.0451	0.0000	1,107.1039

Mitigated Construction On-Site

	ROG	NOx	CO	SO2	Fugitive PM10	Exhaust PM10	PM10 Total	Fugitive PM2.5	Exhaust PM2.5	PM2.5 Total	Bio- CO2	NBio- CO2	Total CO2	CH4	N2O	CO2e
Category	tons/yr										MT/yr					
Off-Road	0.2158	1.9754	2.0700	3.4100e-003		0.1023	0.1023		0.0963	0.0963	0.0000	293.1321	293.1321	0.0702	0.0000	294.8877
Total	0.2158	1.9754	2.0700	3.4100e-003		0.1023	0.1023		0.0963	0.0963	0.0000	293.1321	293.1321	0.0702	0.0000	294.8877

Village South Specific Plan (Proposed) - Los Angeles-South Coast County, Annual

3.5 Building Construction - 2022

Mitigated Construction Off-Site

	ROG	NOx	CO	SO2	Fugitive PM10	Exhaust PM10	PM10 Total	Fugitive PM2.5	Exhaust PM2.5	PM2.5 Total	Bio- CO2	NBio- CO2	Total CO2	CH4	N2O	CO2e
Category	tons/yr										MT/yr					
Hauling	0.0000	0.0000	0.0000	0.0000	0.0000	0.0000	0.0000	0.0000	0.0000	0.0000	0.0000	0.0000	0.0000	0.0000	0.0000	0.0000
Vendor	0.0527	1.6961	0.4580	4.5500e-003	0.1140	3.1800e-003	0.1171	0.0329	3.0400e-003	0.0359	0.0000	441.9835	441.9835	0.0264	0.0000	442.6435
Worker	0.3051	0.2164	2.5233	7.3500e-003	0.7557	6.2300e-003	0.7619	0.2007	5.7400e-003	0.2065	0.0000	663.9936	663.9936	0.0187	0.0000	664.4604
Total	0.3578	1.9125	2.9812	0.0119	0.8696	9.4100e-003	0.8790	0.2336	8.7800e-003	0.2424	0.0000	1,105.9771	1,105.9771	0.0451	0.0000	1,107.1039

3.5 Building Construction - 2023

Unmitigated Construction On-Site

	ROG	NOx	CO	SO2	Fugitive PM10	Exhaust PM10	PM10 Total	Fugitive PM2.5	Exhaust PM2.5	PM2.5 Total	Bio- CO2	NBio- CO2	Total CO2	CH4	N2O	CO2e
Category	tons/yr										MT/yr					
Off-Road	0.1942	1.7765	2.0061	3.3300e-003		0.0864	0.0864		0.0813	0.0813	0.0000	286.2789	286.2789	0.0681	0.0000	287.9814
Total	0.1942	1.7765	2.0061	3.3300e-003		0.0864	0.0864		0.0813	0.0813	0.0000	286.2789	286.2789	0.0681	0.0000	287.9814

Village South Specific Plan (Proposed) - Los Angeles-South Coast County, Annual

3.5 Building Construction - 2023

Unmitigated Construction Off-Site

	ROG	NOx	CO	SO2	Fugitive PM10	Exhaust PM10	PM10 Total	Fugitive PM2.5	Exhaust PM2.5	PM2.5 Total	Bio- CO2	NBio- CO2	Total CO2	CH4	N2O	CO2e
Category	tons/yr										MT/yr					
Hauling	0.0000	0.0000	0.0000	0.0000	0.0000	0.0000	0.0000	0.0000	0.0000	0.0000	0.0000	0.0000	0.0000	0.0000	0.0000	0.0000
Vendor	0.0382	1.2511	0.4011	4.3000e-003	0.1113	1.4600e-003	0.1127	0.0321	1.4000e-003	0.0335	0.0000	417.9930	417.9930	0.0228	0.0000	418.5624
Worker	0.2795	0.1910	2.2635	6.9100e-003	0.7377	5.9100e-003	0.7436	0.1960	5.4500e-003	0.2014	0.0000	624.5363	624.5363	0.0164	0.0000	624.9466
Total	0.3177	1.4420	2.6646	0.0112	0.8490	7.3700e-003	0.8564	0.2281	6.8500e-003	0.2349	0.0000	1,042.5294	1,042.5294	0.0392	0.0000	1,043.5090

Mitigated Construction On-Site

	ROG	NOx	CO	SO2	Fugitive PM10	Exhaust PM10	PM10 Total	Fugitive PM2.5	Exhaust PM2.5	PM2.5 Total	Bio- CO2	NBio- CO2	Total CO2	CH4	N2O	CO2e
Category	tons/yr										MT/yr					
Off-Road	0.1942	1.7765	2.0061	3.3300e-003		0.0864	0.0864		0.0813	0.0813	0.0000	286.2785	286.2785	0.0681	0.0000	287.9811
Total	0.1942	1.7765	2.0061	3.3300e-003		0.0864	0.0864		0.0813	0.0813	0.0000	286.2785	286.2785	0.0681	0.0000	287.9811

Village South Specific Plan (Proposed) - Los Angeles-South Coast County, Annual

3.5 Building Construction - 2023

Mitigated Construction Off-Site

	ROG	NOx	CO	SO2	Fugitive PM10	Exhaust PM10	PM10 Total	Fugitive PM2.5	Exhaust PM2.5	PM2.5 Total	Bio- CO2	NBio- CO2	Total CO2	CH4	N2O	CO2e
Category	tons/yr										MT/yr					
Hauling	0.0000	0.0000	0.0000	0.0000	0.0000	0.0000	0.0000	0.0000	0.0000	0.0000	0.0000	0.0000	0.0000	0.0000	0.0000	0.0000
Vendor	0.0382	1.2511	0.4011	4.3000e-003	0.1113	1.4600e-003	0.1127	0.0321	1.4000e-003	0.0335	0.0000	417.9930	417.9930	0.0228	0.0000	418.5624
Worker	0.2795	0.1910	2.2635	6.9100e-003	0.7377	5.9100e-003	0.7436	0.1960	5.4500e-003	0.2014	0.0000	624.5363	624.5363	0.0164	0.0000	624.9466
Total	0.3177	1.4420	2.6646	0.0112	0.8490	7.3700e-003	0.8564	0.2281	6.8500e-003	0.2349	0.0000	1,042.5294	1,042.5294	0.0392	0.0000	1,043.5090

3.6 Paving - 2023

Unmitigated Construction On-Site

	ROG	NOx	CO	SO2	Fugitive PM10	Exhaust PM10	PM10 Total	Fugitive PM2.5	Exhaust PM2.5	PM2.5 Total	Bio- CO2	NBio- CO2	Total CO2	CH4	N2O	CO2e
Category	tons/yr										MT/yr					
Off-Road	6.7100e-003	0.0663	0.0948	1.5000e-004		3.3200e-003	3.3200e-003		3.0500e-003	3.0500e-003	0.0000	13.0175	13.0175	4.2100e-003	0.0000	13.1227
Paving	0.0000					0.0000	0.0000		0.0000	0.0000	0.0000	0.0000	0.0000	0.0000	0.0000	0.0000
Total	6.7100e-003	0.0663	0.0948	1.5000e-004		3.3200e-003	3.3200e-003		3.0500e-003	3.0500e-003	0.0000	13.0175	13.0175	4.2100e-003	0.0000	13.1227

Village South Specific Plan (Proposed) - Los Angeles-South Coast County, Annual

3.6 Paving - 2023

Unmitigated Construction Off-Site

	ROG	NOx	CO	SO2	Fugitive PM10	Exhaust PM10	PM10 Total	Fugitive PM2.5	Exhaust PM2.5	PM2.5 Total	Bio- CO2	NBio- CO2	Total CO2	CH4	N2O	CO2e
Category	tons/yr										MT/yr					
Hauling	0.0000	0.0000	0.0000	0.0000	0.0000	0.0000	0.0000	0.0000	0.0000	0.0000	0.0000	0.0000	0.0000	0.0000	0.0000	0.0000
Vendor	0.0000	0.0000	0.0000	0.0000	0.0000	0.0000	0.0000	0.0000	0.0000	0.0000	0.0000	0.0000	0.0000	0.0000	0.0000	0.0000
Worker	2.8000e-004	1.9000e-004	2.2300e-003	1.0000e-005	7.3000e-004	1.0000e-005	7.3000e-004	1.9000e-004	1.0000e-005	2.0000e-004	0.0000	0.6156	0.6156	2.0000e-005	0.0000	0.6160
Total	2.8000e-004	1.9000e-004	2.2300e-003	1.0000e-005	7.3000e-004	1.0000e-005	7.3000e-004	1.9000e-004	1.0000e-005	2.0000e-004	0.0000	0.6156	0.6156	2.0000e-005	0.0000	0.6160

Mitigated Construction On-Site

	ROG	NOx	CO	SO2	Fugitive PM10	Exhaust PM10	PM10 Total	Fugitive PM2.5	Exhaust PM2.5	PM2.5 Total	Bio- CO2	NBio- CO2	Total CO2	CH4	N2O	CO2e
Category	tons/yr										MT/yr					
Off-Road	6.7100e-003	0.0663	0.0948	1.5000e-004		3.3200e-003	3.3200e-003		3.0500e-003	3.0500e-003	0.0000	13.0175	13.0175	4.2100e-003	0.0000	13.1227
Paving	0.0000					0.0000	0.0000		0.0000	0.0000	0.0000	0.0000	0.0000	0.0000	0.0000	0.0000
Total	6.7100e-003	0.0663	0.0948	1.5000e-004		3.3200e-003	3.3200e-003		3.0500e-003	3.0500e-003	0.0000	13.0175	13.0175	4.2100e-003	0.0000	13.1227

Village South Specific Plan (Proposed) - Los Angeles-South Coast County, Annual

3.6 Paving - 2023

Mitigated Construction Off-Site

	ROG	NOx	CO	SO2	Fugitive PM10	Exhaust PM10	PM10 Total	Fugitive PM2.5	Exhaust PM2.5	PM2.5 Total	Bio- CO2	NBio- CO2	Total CO2	CH4	N2O	CO2e
Category	tons/yr										MT/yr					
Hauling	0.0000	0.0000	0.0000	0.0000	0.0000	0.0000	0.0000	0.0000	0.0000	0.0000	0.0000	0.0000	0.0000	0.0000	0.0000	0.0000
Vendor	0.0000	0.0000	0.0000	0.0000	0.0000	0.0000	0.0000	0.0000	0.0000	0.0000	0.0000	0.0000	0.0000	0.0000	0.0000	0.0000
Worker	2.8000e-004	1.9000e-004	2.2300e-003	1.0000e-005	7.3000e-004	1.0000e-005	7.3000e-004	1.9000e-004	1.0000e-005	2.0000e-004	0.0000	0.6156	0.6156	2.0000e-005	0.0000	0.6160
Total	2.8000e-004	1.9000e-004	2.2300e-003	1.0000e-005	7.3000e-004	1.0000e-005	7.3000e-004	1.9000e-004	1.0000e-005	2.0000e-004	0.0000	0.6156	0.6156	2.0000e-005	0.0000	0.6160

3.6 Paving - 2024

Unmitigated Construction On-Site

	ROG	NOx	CO	SO2	Fugitive PM10	Exhaust PM10	PM10 Total	Fugitive PM2.5	Exhaust PM2.5	PM2.5 Total	Bio- CO2	NBio- CO2	Total CO2	CH4	N2O	CO2e
Category	tons/yr										MT/yr					
Off-Road	0.0109	0.1048	0.1609	2.5000e-004		5.1500e-003	5.1500e-003		4.7400e-003	4.7400e-003	0.0000	22.0292	22.0292	7.1200e-003	0.0000	22.2073
Paving	0.0000					0.0000	0.0000		0.0000	0.0000	0.0000	0.0000	0.0000	0.0000	0.0000	0.0000
Total	0.0109	0.1048	0.1609	2.5000e-004		5.1500e-003	5.1500e-003		4.7400e-003	4.7400e-003	0.0000	22.0292	22.0292	7.1200e-003	0.0000	22.2073

Village South Specific Plan (Proposed) - Los Angeles-South Coast County, Annual

3.6 Paving - 2024

Unmitigated Construction Off-Site

	ROG	NOx	CO	SO2	Fugitive PM10	Exhaust PM10	PM10 Total	Fugitive PM2.5	Exhaust PM2.5	PM2.5 Total	Bio- CO2	NBio- CO2	Total CO2	CH4	N2O	CO2e
Category	tons/yr										MT/yr					
Hauling	0.0000	0.0000	0.0000	0.0000	0.0000	0.0000	0.0000	0.0000	0.0000	0.0000	0.0000	0.0000	0.0000	0.0000	0.0000	0.0000
Vendor	0.0000	0.0000	0.0000	0.0000	0.0000	0.0000	0.0000	0.0000	0.0000	0.0000	0.0000	0.0000	0.0000	0.0000	0.0000	0.0000
Worker	4.4000e-004	2.9000e-004	3.5100e-003	1.0000e-005	1.2300e-003	1.0000e-005	1.2400e-003	3.3000e-004	1.0000e-005	3.4000e-004	0.0000	1.0094	1.0094	3.0000e-005	0.0000	1.0100
Total	4.4000e-004	2.9000e-004	3.5100e-003	1.0000e-005	1.2300e-003	1.0000e-005	1.2400e-003	3.3000e-004	1.0000e-005	3.4000e-004	0.0000	1.0094	1.0094	3.0000e-005	0.0000	1.0100

Mitigated Construction On-Site

	ROG	NOx	CO	SO2	Fugitive PM10	Exhaust PM10	PM10 Total	Fugitive PM2.5	Exhaust PM2.5	PM2.5 Total	Bio- CO2	NBio- CO2	Total CO2	CH4	N2O	CO2e
Category	tons/yr										MT/yr					
Off-Road	0.0109	0.1048	0.1609	2.5000e-004		5.1500e-003	5.1500e-003		4.7400e-003	4.7400e-003	0.0000	22.0292	22.0292	7.1200e-003	0.0000	22.2073
Paving	0.0000					0.0000	0.0000		0.0000	0.0000	0.0000	0.0000	0.0000	0.0000	0.0000	0.0000
Total	0.0109	0.1048	0.1609	2.5000e-004		5.1500e-003	5.1500e-003		4.7400e-003	4.7400e-003	0.0000	22.0292	22.0292	7.1200e-003	0.0000	22.2073

Village South Specific Plan (Proposed) - Los Angeles-South Coast County, Annual

3.6 Paving - 2024

Mitigated Construction Off-Site

	ROG	NOx	CO	SO2	Fugitive PM10	Exhaust PM10	PM10 Total	Fugitive PM2.5	Exhaust PM2.5	PM2.5 Total	Bio- CO2	NBio- CO2	Total CO2	CH4	N2O	CO2e
Category	tons/yr										MT/yr					
Hauling	0.0000	0.0000	0.0000	0.0000	0.0000	0.0000	0.0000	0.0000	0.0000	0.0000	0.0000	0.0000	0.0000	0.0000	0.0000	0.0000
Vendor	0.0000	0.0000	0.0000	0.0000	0.0000	0.0000	0.0000	0.0000	0.0000	0.0000	0.0000	0.0000	0.0000	0.0000	0.0000	0.0000
Worker	4.4000e-004	2.9000e-004	3.5100e-003	1.0000e-005	1.2300e-003	1.0000e-005	1.2400e-003	3.3000e-004	1.0000e-005	3.4000e-004	0.0000	1.0094	1.0094	3.0000e-005	0.0000	1.0100
Total	4.4000e-004	2.9000e-004	3.5100e-003	1.0000e-005	1.2300e-003	1.0000e-005	1.2400e-003	3.3000e-004	1.0000e-005	3.4000e-004	0.0000	1.0094	1.0094	3.0000e-005	0.0000	1.0100

3.7 Architectural Coating - 2024

Unmitigated Construction On-Site

	ROG	NOx	CO	SO2	Fugitive PM10	Exhaust PM10	PM10 Total	Fugitive PM2.5	Exhaust PM2.5	PM2.5 Total	Bio- CO2	NBio- CO2	Total CO2	CH4	N2O	CO2e
Category	tons/yr										MT/yr					
Archit. Coating	4.1372					0.0000	0.0000		0.0000	0.0000	0.0000	0.0000	0.0000	0.0000	0.0000	0.0000
Off-Road	3.1600e-003	0.0213	0.0317	5.0000e-005		1.0700e-003	1.0700e-003		1.0700e-003	1.0700e-003	0.0000	4.4682	4.4682	2.5000e-004	0.0000	4.4745
Total	4.1404	0.0213	0.0317	5.0000e-005		1.0700e-003	1.0700e-003		1.0700e-003	1.0700e-003	0.0000	4.4682	4.4682	2.5000e-004	0.0000	4.4745

Village South Specific Plan (Proposed) - Los Angeles-South Coast County, Annual

3.7 Architectural Coating - 2024

Unmitigated Construction Off-Site

	ROG	NOx	CO	SO2	Fugitive PM10	Exhaust PM10	PM10 Total	Fugitive PM2.5	Exhaust PM2.5	PM2.5 Total	Bio- CO2	NBio- CO2	Total CO2	CH4	N2O	CO2e
Category	tons/yr										MT/yr					
Hauling	0.0000	0.0000	0.0000	0.0000	0.0000	0.0000	0.0000	0.0000	0.0000	0.0000	0.0000	0.0000	0.0000	0.0000	0.0000	0.0000
Vendor	0.0000	0.0000	0.0000	0.0000	0.0000	0.0000	0.0000	0.0000	0.0000	0.0000	0.0000	0.0000	0.0000	0.0000	0.0000	0.0000
Worker	7.4800e-003	4.9300e-003	0.0596	1.9000e-004	0.0209	1.6000e-004	0.0211	5.5500e-003	1.5000e-004	5.7000e-003	0.0000	17.1287	17.1287	4.3000e-004	0.0000	17.1394
Total	7.4800e-003	4.9300e-003	0.0596	1.9000e-004	0.0209	1.6000e-004	0.0211	5.5500e-003	1.5000e-004	5.7000e-003	0.0000	17.1287	17.1287	4.3000e-004	0.0000	17.1394

Mitigated Construction On-Site

	ROG	NOx	CO	SO2	Fugitive PM10	Exhaust PM10	PM10 Total	Fugitive PM2.5	Exhaust PM2.5	PM2.5 Total	Bio- CO2	NBio- CO2	Total CO2	CH4	N2O	CO2e
Category	tons/yr										MT/yr					
Archit. Coating	4.1372					0.0000	0.0000		0.0000	0.0000	0.0000	0.0000	0.0000	0.0000	0.0000	0.0000
Off-Road	3.1600e-003	0.0213	0.0317	5.0000e-005		1.0700e-003	1.0700e-003		1.0700e-003	1.0700e-003	0.0000	4.4682	4.4682	2.5000e-004	0.0000	4.4745
Total	4.1404	0.0213	0.0317	5.0000e-005		1.0700e-003	1.0700e-003		1.0700e-003	1.0700e-003	0.0000	4.4682	4.4682	2.5000e-004	0.0000	4.4745

Village South Specific Plan (Proposed) - Los Angeles-South Coast County, Annual

3.7 Architectural Coating - 2024

Mitigated Construction Off-Site

	ROG	NOx	CO	SO2	Fugitive PM10	Exhaust PM10	PM10 Total	Fugitive PM2.5	Exhaust PM2.5	PM2.5 Total	Bio- CO2	NBio- CO2	Total CO2	CH4	N2O	CO2e
Category	tons/yr										MT/yr					
Hauling	0.0000	0.0000	0.0000	0.0000	0.0000	0.0000	0.0000	0.0000	0.0000	0.0000	0.0000	0.0000	0.0000	0.0000	0.0000	0.0000
Vendor	0.0000	0.0000	0.0000	0.0000	0.0000	0.0000	0.0000	0.0000	0.0000	0.0000	0.0000	0.0000	0.0000	0.0000	0.0000	0.0000
Worker	7.4800e-003	4.9300e-003	0.0596	1.9000e-004	0.0209	1.6000e-004	0.0211	5.5500e-003	1.5000e-004	5.7000e-003	0.0000	17.1287	17.1287	4.3000e-004	0.0000	17.1394
Total	7.4800e-003	4.9300e-003	0.0596	1.9000e-004	0.0209	1.6000e-004	0.0211	5.5500e-003	1.5000e-004	5.7000e-003	0.0000	17.1287	17.1287	4.3000e-004	0.0000	17.1394

4.0 Operational Detail - Mobile

4.1 Mitigation Measures Mobile

Village South Specific Plan (Proposed) - Los Angeles-South Coast County, Annual

	ROG	NOx	CO	SO2	Fugitive PM10	Exhaust PM10	PM10 Total	Fugitive PM2.5	Exhaust PM2.5	PM2.5 Total	Bio- CO2	NBio- CO2	Total CO2	CH4	N2O	CO2e
Category	tons/yr										MT/yr					
Mitigated	1.5857	7.9962	19.1834	0.0821	7.7979	0.0580	7.8559	2.0895	0.0539	2.1434	0.0000	7,620.4986	7,620.4986	0.3407	0.0000	7,629.0162
Unmitigated	1.5857	7.9962	19.1834	0.0821	7.7979	0.0580	7.8559	2.0895	0.0539	2.1434	0.0000	7,620.4986	7,620.4986	0.3407	0.0000	7,629.0162

4.2 Trip Summary Information

Land Use	Average Daily Trip Rate			Unmitigated	Mitigated
	Weekday	Saturday	Sunday	Annual VMT	Annual VMT
Apartments Low Rise	145.75	154.25	154.00	506,227	506,227
Apartments Mid Rise	4,026.75	3,773.25	4075.50	13,660,065	13,660,065
General Office Building	288.45	62.55	31.05	706,812	706,812
High Turnover (Sit Down Restaurant)	2,368.80	2,873.52	2817.72	3,413,937	3,413,937
Hotel	192.00	187.50	160.00	445,703	445,703
Quality Restaurant	501.12	511.92	461.20	707,488	707,488
Regional Shopping Center	528.08	601.44	357.84	1,112,221	1,112,221
Total	8,050.95	8,164.43	8,057.31	20,552,452	20,552,452

4.3 Trip Type Information

Village South Specific Plan (Proposed) - Los Angeles-South Coast County, Annual

Land Use	Miles			Trip %			Trip Purpose %		
	H-W or C-W	H-S or C-C	H-O or C-NW	H-W or C-W	H-S or C-C	H-O or C-NW	Primary	Diverted	Pass-by
Apartments Low Rise	14.70	5.90	8.70	40.20	19.20	40.60	86	11	3
Apartments Mid Rise	14.70	5.90	8.70	40.20	19.20	40.60	86	11	3
General Office Building	16.60	8.40	6.90	33.00	48.00	19.00	77	19	4
High Turnover (Sit Down Restaurant)	16.60	8.40	6.90	8.50	72.50	19.00	37	20	43
Hotel	16.60	8.40	6.90	19.40	61.60	19.00	58	38	4
Quality Restaurant	16.60	8.40	6.90	12.00	69.00	19.00	38	18	44
Regional Shopping Center	16.60	8.40	6.90	16.30	64.70	19.00	54	35	11

4.4 Fleet Mix

Land Use	LDA	LDT1	LDT2	MDV	LHD1	LHD2	MHD	HHD	OBUS	UBUS	MCY	SBUS	MH
Apartments Low Rise	0.543088	0.044216	0.209971	0.116369	0.014033	0.006332	0.021166	0.033577	0.002613	0.001817	0.005285	0.000712	0.000821
Apartments Mid Rise	0.543088	0.044216	0.209971	0.116369	0.014033	0.006332	0.021166	0.033577	0.002613	0.001817	0.005285	0.000712	0.000821
General Office Building	0.543088	0.044216	0.209971	0.116369	0.014033	0.006332	0.021166	0.033577	0.002613	0.001817	0.005285	0.000712	0.000821
High Turnover (Sit Down Restaurant)	0.543088	0.044216	0.209971	0.116369	0.014033	0.006332	0.021166	0.033577	0.002613	0.001817	0.005285	0.000712	0.000821
Hotel	0.543088	0.044216	0.209971	0.116369	0.014033	0.006332	0.021166	0.033577	0.002613	0.001817	0.005285	0.000712	0.000821
Quality Restaurant	0.543088	0.044216	0.209971	0.116369	0.014033	0.006332	0.021166	0.033577	0.002613	0.001817	0.005285	0.000712	0.000821
Regional Shopping Center	0.543088	0.044216	0.209971	0.116369	0.014033	0.006332	0.021166	0.033577	0.002613	0.001817	0.005285	0.000712	0.000821

5.0 Energy Detail

Historical Energy Use: N

5.1 Mitigation Measures Energy

Village South Specific Plan (Proposed) - Los Angeles-South Coast County, Annual

	ROG	NOx	CO	SO2	Fugitive PM10	Exhaust PM10	PM10 Total	Fugitive PM2.5	Exhaust PM2.5	PM2.5 Total	Bio- CO2	NBio- CO2	Total CO2	CH4	N2O	CO2e
Category	tons/yr										MT/yr					
Electricity Mitigated							0.0000	0.0000		0.0000	0.0000	2,512.6465	2,512.6465	0.1037	0.0215	2,521.6356
Electricity Unmitigated							0.0000	0.0000		0.0000	0.0000	2,512.6465	2,512.6465	0.1037	0.0215	2,521.6356
NaturalGas Mitigated	0.1398	1.2312	0.7770	7.6200e-003		0.0966	0.0966		0.0966	0.0966	0.0000	1,383.4267	1,383.4267	0.0265	0.0254	1,391.6478
NaturalGas Unmitigated	0.1398	1.2312	0.7770	7.6200e-003		0.0966	0.0966		0.0966	0.0966	0.0000	1,383.4267	1,383.4267	0.0265	0.0254	1,391.6478

Village South Specific Plan (Proposed) - Los Angeles-South Coast County, Annual

5.2 Energy by Land Use - NaturalGas

Unmitigated

	NaturalGas Use	ROG	NOx	CO	SO2	Fugitive PM10	Exhaust PM10	PM10 Total	Fugitive PM2.5	Exhaust PM2.5	PM2.5 Total	Bio- CO2	NBio- CO2	Total CO2	CH4	N2O	CO2e
Land Use	kBTU/yr	tons/yr										MT/yr					
Apartments Low Rise	408494	2.2000e-003	0.0188	8.0100e-003	1.2000e-004		1.5200e-003	1.5200e-003		1.5200e-003	1.5200e-003	0.0000	21.7988	21.7988	4.2000e-004	4.0000e-004	21.9284
Apartments Mid Rise	1.30613e+007	0.0704	0.6018	0.2561	3.8400e-003		0.0487	0.0487		0.0487	0.0487	0.0000	696.9989	696.9989	0.0134	0.0128	701.1408
General Office Building	468450	2.5300e-003	0.0230	0.0193	1.4000e-004		1.7500e-003	1.7500e-003		1.7500e-003	1.7500e-003	0.0000	24.9983	24.9983	4.8000e-004	4.6000e-004	25.1468
High Turnover (Sit Down Restaurant)	8.30736e+006	0.0448	0.4072	0.3421	2.4400e-003		0.0310	0.0310		0.0310	0.0310	0.0000	443.3124	443.3124	8.5000e-003	8.1300e-003	445.9468
Hotel	1.74095e+006	9.3900e-003	0.0853	0.0717	5.1000e-004		6.4900e-003	6.4900e-003		6.4900e-003	6.4900e-003	0.0000	92.9036	92.9036	1.7800e-003	1.7000e-003	93.4557
Quality Restaurant	1.84608e+006	9.9500e-003	0.0905	0.0760	5.4000e-004		6.8800e-003	6.8800e-003		6.8800e-003	6.8800e-003	0.0000	98.5139	98.5139	1.8900e-003	1.8100e-003	99.0993
Regional Shopping Center	91840	5.0000e-004	4.5000e-003	3.7800e-003	3.0000e-005		3.4000e-004	3.4000e-004		3.4000e-004	3.4000e-004	0.0000	4.9009	4.9009	9.0000e-005	9.0000e-005	4.9301
Total		0.1398	1.2312	0.7770	7.6200e-003		0.0966	0.0966		0.0966	0.0966	0.0000	1,383.4268	1,383.4268	0.0265	0.0254	1,391.6478

Village South Specific Plan (Proposed) - Los Angeles-South Coast County, Annual

5.2 Energy by Land Use - NaturalGas

Mitigated

	NaturalGas Use	ROG	NOx	CO	SO2	Fugitive PM10	Exhaust PM10	PM10 Total	Fugitive PM2.5	Exhaust PM2.5	PM2.5 Total	Bio- CO2	NBio- CO2	Total CO2	CH4	N2O	CO2e
Land Use	kBTU/yr	tons/yr										MT/yr					
Apartments Low Rise	408494	2.2000e-003	0.0188	8.0100e-003	1.2000e-004		1.5200e-003	1.5200e-003		1.5200e-003	1.5200e-003	0.0000	21.7988	21.7988	4.2000e-004	4.0000e-004	21.9284
Apartments Mid Rise	1.30613e+007	0.0704	0.6018	0.2561	3.8400e-003		0.0487	0.0487		0.0487	0.0487	0.0000	696.9989	696.9989	0.0134	0.0128	701.1408
General Office Building	468450	2.5300e-003	0.0230	0.0193	1.4000e-004		1.7500e-003	1.7500e-003		1.7500e-003	1.7500e-003	0.0000	24.9983	24.9983	4.8000e-004	4.6000e-004	25.1468
High Turnover (Sit Down Restaurant)	8.30736e+006	0.0448	0.4072	0.3421	2.4400e-003		0.0310	0.0310		0.0310	0.0310	0.0000	443.3124	443.3124	8.5000e-003	8.1300e-003	445.9468
Hotel	1.74095e+006	9.3900e-003	0.0853	0.0717	5.1000e-004		6.4900e-003	6.4900e-003		6.4900e-003	6.4900e-003	0.0000	92.9036	92.9036	1.7800e-003	1.7000e-003	93.4557
Quality Restaurant	1.84608e+006	9.9500e-003	0.0905	0.0760	5.4000e-004		6.8800e-003	6.8800e-003		6.8800e-003	6.8800e-003	0.0000	98.5139	98.5139	1.8900e-003	1.8100e-003	99.0993
Regional Shopping Center	91840	5.0000e-004	4.5000e-003	3.7800e-003	3.0000e-005		3.4000e-004	3.4000e-004		3.4000e-004	3.4000e-004	0.0000	4.9009	4.9009	9.0000e-005	9.0000e-005	4.9301
Total		0.1398	1.2312	0.7770	7.6200e-003		0.0966	0.0966		0.0966	0.0966	0.0000	1,383.4268	1,383.4268	0.0265	0.0254	1,391.6478

Village South Specific Plan (Proposed) - Los Angeles-South Coast County, Annual

5.3 Energy by Land Use - Electricity

Unmitigated

	Electricity Use	Total CO2	CH4	N2O	CO2e
Land Use	kWh/yr	MT/yr			
Apartments Low Rise	106010	33.7770	1.3900e-003	2.9000e-004	33.8978
Apartments Mid Rise	3.94697e+006	1,257.5879	0.0519	0.0107	1,262.0869
General Office Building	584550	186.2502	7.6900e-003	1.5900e-003	186.9165
High Turnover (Sit Down Restaurant)	1.58904e+006	506.3022	0.0209	4.3200e-003	508.1135
Hotel	550308	175.3399	7.2400e-003	1.5000e-003	175.9672
Quality Restaurant	353120	112.5116	4.6500e-003	9.6000e-004	112.9141
Regional Shopping Center	756000	240.8778	9.9400e-003	2.0600e-003	241.7395
Total		2,512.6465	0.1037	0.0215	2,521.6356

Village South Specific Plan (Proposed) - Los Angeles-South Coast County, Annual

5.3 Energy by Land Use - Electricity

Mitigated

	Electricity Use	Total CO2	CH4	N2O	CO2e
Land Use	kWh/yr	MT/yr			
Apartments Low Rise	106010	33.7770	1.3900e-003	2.9000e-004	33.8978
Apartments Mid Rise	3.94697e+006	1,257.5879	0.0519	0.0107	1,262.0869
General Office Building	584550	186.2502	7.6900e-003	1.5900e-003	186.9165
High Turnover (Sit Down Restaurant)	1.58904e+006	506.3022	0.0209	4.3200e-003	508.1135
Hotel	550308	175.3399	7.2400e-003	1.5000e-003	175.9672
Quality Restaurant	353120	112.5116	4.6500e-003	9.6000e-004	112.9141
Regional Shopping Center	756000	240.8778	9.9400e-003	2.0600e-003	241.7395
Total		2,512.6465	0.1037	0.0215	2,521.6356

6.0 Area Detail

6.1 Mitigation Measures Area

Village South Specific Plan (Proposed) - Los Angeles-South Coast County, Annual

	ROG	NOx	CO	SO2	Fugitive PM10	Exhaust PM10	PM10 Total	Fugitive PM2.5	Exhaust PM2.5	PM2.5 Total	Bio- CO2	NBio- CO2	Total CO2	CH4	N2O	CO2e
Category	tons/yr										MT/yr					
Mitigated	5.1437	0.2950	10.3804	1.6700e-003		0.0714	0.0714		0.0714	0.0714	0.0000	220.9670	220.9670	0.0201	3.7400e-003	222.5835
Unmitigated	5.1437	0.2950	10.3804	1.6700e-003		0.0714	0.0714		0.0714	0.0714	0.0000	220.9670	220.9670	0.0201	3.7400e-003	222.5835

6.2 Area by SubCategory

Unmitigated

	ROG	NOx	CO	SO2	Fugitive PM10	Exhaust PM10	PM10 Total	Fugitive PM2.5	Exhaust PM2.5	PM2.5 Total	Bio- CO2	NBio- CO2	Total CO2	CH4	N2O	CO2e
SubCategory	tons/yr										MT/yr					
Architectural Coating	0.4137					0.0000	0.0000		0.0000	0.0000	0.0000	0.0000	0.0000	0.0000	0.0000	0.0000
Consumer Products	4.3998					0.0000	0.0000		0.0000	0.0000	0.0000	0.0000	0.0000	0.0000	0.0000	0.0000
Hearth	0.0206	0.1763	0.0750	1.1200e-003		0.0143	0.0143		0.0143	0.0143	0.0000	204.1166	204.1166	3.9100e-003	3.7400e-003	205.3295
Landscaping	0.3096	0.1187	10.3054	5.4000e-004		0.0572	0.0572		0.0572	0.0572	0.0000	16.8504	16.8504	0.0161	0.0000	17.2540
Total	5.1437	0.2950	10.3804	1.6600e-003		0.0714	0.0714		0.0714	0.0714	0.0000	220.9670	220.9670	0.0201	3.7400e-003	222.5835

Village South Specific Plan (Proposed) - Los Angeles-South Coast County, Annual

6.2 Area by SubCategory

Mitigated

	ROG	NOx	CO	SO2	Fugitive PM10	Exhaust PM10	PM10 Total	Fugitive PM2.5	Exhaust PM2.5	PM2.5 Total	Bio- CO2	NBio- CO2	Total CO2	CH4	N2O	CO2e
SubCategory	tons/yr										MT/yr					
Architectural Coating	0.4137					0.0000	0.0000		0.0000	0.0000	0.0000	0.0000	0.0000	0.0000	0.0000	0.0000
Consumer Products	4.3998					0.0000	0.0000		0.0000	0.0000	0.0000	0.0000	0.0000	0.0000	0.0000	0.0000
Hearth	0.0206	0.1763	0.0750	1.1200e-003		0.0143	0.0143		0.0143	0.0143	0.0000	204.1166	204.1166	3.9100e-003	3.7400e-003	205.3295
Landscaping	0.3096	0.1187	10.3054	5.4000e-004		0.0572	0.0572		0.0572	0.0572	0.0000	16.8504	16.8504	0.0161	0.0000	17.2540
Total	5.1437	0.2950	10.3804	1.6600e-003		0.0714	0.0714		0.0714	0.0714	0.0000	220.9670	220.9670	0.0201	3.7400e-003	222.5835

7.0 Water Detail

7.1 Mitigation Measures Water

Village South Specific Plan (Proposed) - Los Angeles-South Coast County, Annual

	Total CO2	CH4	N2O	CO2e
Category	MT/yr			
Mitigated	585.8052	3.0183	0.0755	683.7567
Unmitigated	585.8052	3.0183	0.0755	683.7567

Village South Specific Plan (Proposed) - Los Angeles-South Coast County, Annual

7.2 Water by Land Use

Unmitigated

	Indoor/Outdoor Use	Total CO2	CH4	N2O	CO2e
Land Use	Mgal	MT/yr			
Apartments Low Rise	1.62885 / 1.02688	10.9095	0.0535	1.3400e-003	12.6471
Apartments Mid Rise	63.5252 / 40.0485	425.4719	2.0867	0.0523	493.2363
General Office Building	7.99802 / 4.90201	53.0719	0.2627	6.5900e-003	61.6019
High Turnover (Sit Down Restaurant)	10.9272 / 0.697482	51.2702	0.3580	8.8200e-003	62.8482
Hotel	1.26834 / 0.140927	6.1633	0.0416	1.0300e-003	7.5079
Quality Restaurant	2.42827 / 0.154996	11.3934	0.0796	1.9600e-003	13.9663
Regional Shopping Center	4.14806 / 2.54236	27.5250	0.1363	3.4200e-003	31.9490
Total		585.8052	3.0183	0.0755	683.7567

Village South Specific Plan (Proposed) - Los Angeles-South Coast County, Annual

7.2 Water by Land Use

Mitigated

	Indoor/Outdoor Use	Total CO2	CH4	N2O	CO2e
Land Use	Mgal	MT/yr			
Apartments Low Rise	1.62885 / 1.02688	10.9095	0.0535	1.3400e-003	12.6471
Apartments Mid Rise	63.5252 / 40.0485	425.4719	2.0867	0.0523	493.2363
General Office Building	7.99802 / 4.90201	53.0719	0.2627	6.5900e-003	61.6019
High Turnover (Sit Down Restaurant)	10.9272 / 0.697482	51.2702	0.3580	8.8200e-003	62.8482
Hotel	1.26834 / 0.140927	6.1633	0.0416	1.0300e-003	7.5079
Quality Restaurant	2.42827 / 0.154996	11.3934	0.0796	1.9600e-003	13.9663
Regional Shopping Center	4.14806 / 2.54236	27.5250	0.1363	3.4200e-003	31.9490
Total		585.8052	3.0183	0.0755	683.7567

8.0 Waste Detail

8.1 Mitigation Measures Waste

Village South Specific Plan (Proposed) - Los Angeles-South Coast County, Annual

Category/Year

	Total CO2	CH4	N2O	CO2e
	MT/yr			
Mitigated	207.8079	12.2811	0.0000	514.8354
Unmitigated	207.8079	12.2811	0.0000	514.8354

Village South Specific Plan (Proposed) - Los Angeles-South Coast County, Annual

8.2 Waste by Land Use

Unmitigated

	Waste Disposed	Total CO2	CH4	N2O	CO2e
Land Use	tons	MT/yr			
Apartments Low Rise	11.5	2.3344	0.1380	0.0000	5.7834
Apartments Mid Rise	448.5	91.0415	5.3804	0.0000	225.5513
General Office Building	41.85	8.4952	0.5021	0.0000	21.0464
High Turnover (Sit Down Restaurant)	428.4	86.9613	5.1393	0.0000	215.4430
Hotel	27.38	5.5579	0.3285	0.0000	13.7694
Quality Restaurant	7.3	1.4818	0.0876	0.0000	3.6712
Regional Shopping Center	58.8	11.9359	0.7054	0.0000	29.5706
Total		207.8079	12.2811	0.0000	514.8354

Village South Specific Plan (Proposed) - Los Angeles-South Coast County, Annual

8.2 Waste by Land Use

Mitigated

	Waste Disposed	Total CO2	CH4	N2O	CO2e
Land Use	tons	MT/yr			
Apartments Low Rise	11.5	2.3344	0.1380	0.0000	5.7834
Apartments Mid Rise	448.5	91.0415	5.3804	0.0000	225.5513
General Office Building	41.85	8.4952	0.5021	0.0000	21.0464
High Turnover (Sit Down Restaurant)	428.4	86.9613	5.1393	0.0000	215.4430
Hotel	27.38	5.5579	0.3285	0.0000	13.7694
Quality Restaurant	7.3	1.4818	0.0876	0.0000	3.6712
Regional Shopping Center	58.8	11.9359	0.7054	0.0000	29.5706
Total		207.8079	12.2811	0.0000	514.8354

9.0 Operational Offroad

Equipment Type	Number	Hours/Day	Days/Year	Horse Power	Load Factor	Fuel Type
----------------	--------	-----------	-----------	-------------	-------------	-----------

10.0 Stationary Equipment

Fire Pumps and Emergency Generators

Equipment Type	Number	Hours/Day	Hours/Year	Horse Power	Load Factor	Fuel Type
----------------	--------	-----------	------------	-------------	-------------	-----------

Village South Specific Plan (Proposed) - Los Angeles-South Coast County, Annual

Boilers

Equipment Type	Number	Heat Input/Day	Heat Input/Year	Boiler Rating	Fuel Type
----------------	--------	----------------	-----------------	---------------	-----------

User Defined Equipment

Equipment Type	Number
----------------	--------

11.0 Vegetation

Village South Specific Plan (Proposed) - Los Angeles-South Coast County, Summer

Village South Specific Plan (Proposed)
Los Angeles-South Coast County, Summer

1.0 Project Characteristics

1.1 Land Usage

Land Uses	Size	Metric	Lot Acreage	Floor Surface Area	Population
General Office Building	45.00	1000sqft	1.03	45,000.00	0
High Turnover (Sit Down Restaurant)	36.00	1000sqft	0.83	36,000.00	0
Hotel	50.00	Room	1.67	72,600.00	0
Quality Restaurant	8.00	1000sqft	0.18	8,000.00	0
Apartments Low Rise	25.00	Dwelling Unit	1.56	25,000.00	72
Apartments Mid Rise	975.00	Dwelling Unit	25.66	975,000.00	2789
Regional Shopping Center	56.00	1000sqft	1.29	56,000.00	0

1.2 Other Project Characteristics

Urbanization	Urban	Wind Speed (m/s)	2.2	Precipitation Freq (Days)	33
Climate Zone	9			Operational Year	2028
Utility Company	Southern California Edison				
CO2 Intensity (lb/MW hr)	702.44	CH4 Intensity (lb/MW hr)	0.029	N2O Intensity (lb/MW hr)	0.006

1.3 User Entered Comments & Non-Default Data

Village South Specific Plan (Proposed) - Los Angeles-South Coast County, Summer

Project Characteristics - Consistent with the DEIR's model.

Land Use - See SWAPE comment regarding residential and retail land uses.

Construction Phase - See SWAPE comment regarding individual construction phase lengths.

Demolition - Consistent with the DEIR's model. See SWAPE comment regarding demolition.

Vehicle Trips - Saturday trips consistent with the DEIR's model. See SWAPE comment regarding weekday and Sunday trips.

Woodstoves - Woodstoves and wood-burning fireplaces consistent with the DEIR's model. See SWAPE comment regarding gas fireplaces.

Energy Use -

Construction Off-road Equipment Mitigation - See SWAPE comment on construction-related mitigation.

Area Mitigation - See SWAPE comment regarding operational mitigation measures.

Water Mitigation - See SWAPE comment regarding operational mitigation measures.

Trips and VMT - Local hire provision

Table Name	Column Name	Default Value	New Value
tblFireplaces	FireplaceWoodMass	1,019.20	0.00
tblFireplaces	FireplaceWoodMass	1,019.20	0.00
tblFireplaces	NumberWood	1.25	0.00
tblFireplaces	NumberWood	48.75	0.00
tblTripsAndVMT	WorkerTripLength	14.70	10.00
tblTripsAndVMT	WorkerTripLength	14.70	10.00
tblTripsAndVMT	WorkerTripLength	14.70	10.00
tblTripsAndVMT	WorkerTripLength	14.70	10.00
tblTripsAndVMT	WorkerTripLength	14.70	10.00
tblTripsAndVMT	WorkerTripLength	14.70	10.00
tblVehicleTrips	ST_TR	7.16	6.17
tblVehicleTrips	ST_TR	6.39	3.87
tblVehicleTrips	ST_TR	2.46	1.39
tblVehicleTrips	ST_TR	158.37	79.82

Village South Specific Plan (Proposed) - Los Angeles-South Coast County, Summer

tblVehicleTrips	ST_TR	8.19	3.75
tblVehicleTrips	ST_TR	94.36	63.99
tblVehicleTrips	ST_TR	49.97	10.74
tblVehicleTrips	SU_TR	6.07	6.16
tblVehicleTrips	SU_TR	5.86	4.18
tblVehicleTrips	SU_TR	1.05	0.69
tblVehicleTrips	SU_TR	131.84	78.27
tblVehicleTrips	SU_TR	5.95	3.20
tblVehicleTrips	SU_TR	72.16	57.65
tblVehicleTrips	SU_TR	25.24	6.39
tblVehicleTrips	WD_TR	6.59	5.83
tblVehicleTrips	WD_TR	6.65	4.13
tblVehicleTrips	WD_TR	11.03	6.41
tblVehicleTrips	WD_TR	127.15	65.80
tblVehicleTrips	WD_TR	8.17	3.84
tblVehicleTrips	WD_TR	89.95	62.64
tblVehicleTrips	WD_TR	42.70	9.43
tblWoodstoves	NumberCatalytic	1.25	0.00
tblWoodstoves	NumberCatalytic	48.75	0.00
tblWoodstoves	NumberNoncatalytic	1.25	0.00
tblWoodstoves	NumberNoncatalytic	48.75	0.00
tblWoodstoves	WoodstoveDayYear	25.00	0.00
tblWoodstoves	WoodstoveDayYear	25.00	0.00
tblWoodstoves	WoodstoveWoodMass	999.60	0.00
tblWoodstoves	WoodstoveWoodMass	999.60	0.00

2.0 Emissions Summary

Village South Specific Plan (Proposed) - Los Angeles-South Coast County, Summer

2.1 Overall Construction (Maximum Daily Emission)

Unmitigated Construction

	ROG	NOx	CO	SO2	Fugitive PM10	Exhaust PM10	PM10 Total	Fugitive PM2.5	Exhaust PM2.5	PM2.5 Total	Bio- CO2	NBio- CO2	Total CO2	CH4	N2O	CO2e
Year	lb/day										lb/day					
2021	4.2561	46.4415	31.4494	0.0636	18.2032	2.0456	20.2488	9.9670	1.8820	11.8490	0.0000	6,163.4166	6,163.4166	1.9475	0.0000	6,212.1039
2022	4.5441	38.8811	40.8776	0.1240	8.8255	1.6361	10.4616	3.6369	1.5052	5.1421	0.0000	12,493.4403	12,493.4403	1.9485	0.0000	12,518.5707
2023	4.1534	25.7658	38.7457	0.1206	7.0088	0.7592	7.7679	1.8799	0.7136	2.5935	0.0000	12,150.4890	12,150.4890	0.9589	0.0000	12,174.4615
2024	237.0219	9.5478	14.9642	0.0239	1.2171	0.4694	1.2875	0.3229	0.4319	0.4621	0.0000	2,313.1808	2,313.1808	0.7166	0.0000	2,331.0956
Maximum	237.0219	46.4415	40.8776	0.1240	18.2032	2.0456	20.2488	9.9670	1.8820	11.8490	0.0000	12,493.4403	12,493.4403	1.9485	0.0000	12,518.5707

Village South Specific Plan (Proposed) - Los Angeles-South Coast County, Summer

2.2 Overall Operational

Unmitigated Operational

	ROG	NOx	CO	SO2	Fugitive PM10	Exhaust PM10	PM10 Total	Fugitive PM2.5	Exhaust PM2.5	PM2.5 Total	Bio- CO2	NBio- CO2	Total CO2	CH4	N2O	CO2e
Category	lb/day										lb/day					
Area	30.5020	15.0496	88.4430	0.0944		1.5974	1.5974		1.5974	1.5974	0.0000	18,148.59 50	18,148.59 50	0.4874	0.3300	18,259.11 92
Energy	0.7660	6.7462	4.2573	0.0418		0.5292	0.5292		0.5292	0.5292		8,355.983 2	8,355.983 2	0.1602	0.1532	8,405.638 7
Mobile	9.8489	45.4304	114.8495	0.4917	45.9592	0.3360	46.2951	12.2950	0.3119	12.6070		50,306.60 34	50,306.60 34	2.1807		50,361.12 08
Total	41.1168	67.2262	207.5497	0.6278	45.9592	2.4626	48.4217	12.2950	2.4385	14.7336	0.0000	76,811.18 16	76,811.18 16	2.8282	0.4832	77,025.87 86

Mitigated Operational

	ROG	NOx	CO	SO2	Fugitive PM10	Exhaust PM10	PM10 Total	Fugitive PM2.5	Exhaust PM2.5	PM2.5 Total	Bio- CO2	NBio- CO2	Total CO2	CH4	N2O	CO2e
Category	lb/day										lb/day					
Area	30.5020	15.0496	88.4430	0.0944		1.5974	1.5974		1.5974	1.5974	0.0000	18,148.59 50	18,148.59 50	0.4874	0.3300	18,259.11 92
Energy	0.7660	6.7462	4.2573	0.0418		0.5292	0.5292		0.5292	0.5292		8,355.983 2	8,355.983 2	0.1602	0.1532	8,405.638 7
Mobile	9.8489	45.4304	114.8495	0.4917	45.9592	0.3360	46.2951	12.2950	0.3119	12.6070		50,306.60 34	50,306.60 34	2.1807		50,361.12 08
Total	41.1168	67.2262	207.5497	0.6278	45.9592	2.4626	48.4217	12.2950	2.4385	14.7336	0.0000	76,811.18 16	76,811.18 16	2.8282	0.4832	77,025.87 86

Village South Specific Plan (Proposed) - Los Angeles-South Coast County, Summer

	ROG	NOx	CO	SO2	Fugitive PM10	Exhaust PM10	PM10 Total	Fugitive PM2.5	Exhaust PM2.5	PM2.5 Total	Bio- CO2	NBio-CO2	Total CO2	CH4	N2O	CO2e
Percent Reduction	0.00	0.00	0.00	0.00	0.00	0.00	0.00	0.00	0.00	0.00	0.00	0.00	0.00	0.00	0.00	0.00

3.0 Construction Detail

Construction Phase

Phase Number	Phase Name	Phase Type	Start Date	End Date	Num Days Week	Num Days	Phase Description
1	Demolition	Demolition	9/1/2021	10/12/2021	5	30	
2	Site Preparation	Site Preparation	10/13/2021	11/9/2021	5	20	
3	Grading	Grading	11/10/2021	1/11/2022	5	45	
4	Building Construction	Building Construction	1/12/2022	12/12/2023	5	500	
5	Paving	Paving	12/13/2023	1/30/2024	5	35	
6	Architectural Coating	Architectural Coating	1/31/2024	3/19/2024	5	35	

Acres of Grading (Site Preparation Phase): 0

Acres of Grading (Grading Phase): 112.5

Acres of Paving: 0

Residential Indoor: 2,025,000; Residential Outdoor: 675,000; Non-Residential Indoor: 326,400; Non-Residential Outdoor: 108,800; Striped Parking Area: 0 (Architectural Coating – sqft)

OffRoad Equipment

Village South Specific Plan (Proposed) - Los Angeles-South Coast County, Summer

Phase Name	Offroad Equipment Type	Amount	Usage Hours	Horse Power	Load Factor
Demolition	Concrete/Industrial Saws	1	8.00	81	0.73
Demolition	Excavators	3	8.00	158	0.38
Demolition	Rubber Tired Dozers	2	8.00	247	0.40
Site Preparation	Rubber Tired Dozers	3	8.00	247	0.40
Site Preparation	Tractors/Loaders/Backhoes	4	8.00	97	0.37
Grading	Excavators	2	8.00	158	0.38
Grading	Graders	1	8.00	187	0.41
Grading	Rubber Tired Dozers	1	8.00	247	0.40
Grading	Scrapers	2	8.00	367	0.48
Grading	Tractors/Loaders/Backhoes	2	8.00	97	0.37
Building Construction	Cranes	1	7.00	231	0.29
Building Construction	Forklifts	3	8.00	89	0.20
Building Construction	Generator Sets	1	8.00	84	0.74
Building Construction	Tractors/Loaders/Backhoes	3	7.00	97	0.37
Building Construction	Welders	1	8.00	46	0.45
Paving	Pavers	2	8.00	130	0.42
Paving	Paving Equipment	2	8.00	132	0.36
Paving	Rollers	2	8.00	80	0.38
Architectural Coating	Air Compressors	1	6.00	78	0.48

Trips and VMT

Village South Specific Plan (Proposed) - Los Angeles-South Coast County, Summer

Phase Name	Offroad Equipment Count	Worker Trip Number	Vendor Trip Number	Hauling Trip Number	Worker Trip Length	Vendor Trip Length	Hauling Trip Length	Worker Vehicle Class	Vendor Vehicle Class	Hauling Vehicle Class
Demolition	6	15.00	0.00	458.00	10.00	6.90	20.00	LD_Mix	HDT_Mix	HHDT
Site Preparation	7	18.00	0.00	0.00	10.00	6.90	20.00	LD_Mix	HDT_Mix	HHDT
Grading	8	20.00	0.00	0.00	10.00	6.90	20.00	LD_Mix	HDT_Mix	HHDT
Building Construction	9	801.00	143.00	0.00	10.00	6.90	20.00	LD_Mix	HDT_Mix	HHDT
Paving	6	15.00	0.00	0.00	10.00	6.90	20.00	LD_Mix	HDT_Mix	HHDT
Architectural Coating	1	160.00	0.00	0.00	10.00	6.90	20.00	LD_Mix	HDT_Mix	HHDT

3.1 Mitigation Measures Construction

3.2 Demolition - 2021

Unmitigated Construction On-Site

	ROG	NOx	CO	SO2	Fugitive PM10	Exhaust PM10	PM10 Total	Fugitive PM2.5	Exhaust PM2.5	PM2.5 Total	Bio- CO2	NBio- CO2	Total CO2	CH4	N2O	CO2e
Category	lb/day										lb/day					
Fugitive Dust					3.3074	0.0000	3.3074	0.5008	0.0000	0.5008			0.0000			0.0000
Off-Road	3.1651	31.4407	21.5650	0.0388		1.5513	1.5513		1.4411	1.4411		3,747.9449	3,747.9449	1.0549		3,774.3174
Total	3.1651	31.4407	21.5650	0.0388	3.3074	1.5513	4.8588	0.5008	1.4411	1.9419		3,747.9449	3,747.9449	1.0549		3,774.3174

Village South Specific Plan (Proposed) - Los Angeles-South Coast County, Summer

3.2 Demolition - 2021

Unmitigated Construction Off-Site

	ROG	NOx	CO	SO2	Fugitive PM10	Exhaust PM10	PM10 Total	Fugitive PM2.5	Exhaust PM2.5	PM2.5 Total	Bio- CO2	NBio- CO2	Total CO2	CH4	N2O	CO2e
Category	lb/day										lb/day					
Hauling	0.1273	4.0952	0.9602	0.0119	0.2669	0.0126	0.2795	0.0732	0.0120	0.0852		1,292.2413	1,292.2413	0.0877		1,294.4337
Vendor	0.0000	0.0000	0.0000	0.0000	0.0000	0.0000	0.0000	0.0000	0.0000	0.0000		0.0000	0.0000	0.0000		0.0000
Worker	0.0487	0.0313	0.4282	1.1800e-003	0.1141	9.5000e-004	0.1151	0.0303	8.8000e-004	0.0311		117.2799	117.2799	3.5200e-003		117.3678
Total	0.1760	4.1265	1.3884	0.0131	0.3810	0.0135	0.3946	0.1034	0.0129	0.1163		1,409.5212	1,409.5212	0.0912		1,411.8015

Mitigated Construction On-Site

	ROG	NOx	CO	SO2	Fugitive PM10	Exhaust PM10	PM10 Total	Fugitive PM2.5	Exhaust PM2.5	PM2.5 Total	Bio- CO2	NBio- CO2	Total CO2	CH4	N2O	CO2e
Category	lb/day										lb/day					
Fugitive Dust					3.3074	0.0000	3.3074	0.5008	0.0000	0.5008			0.0000			0.0000
Off-Road	3.1651	31.4407	21.5650	0.0388		1.5513	1.5513		1.4411	1.4411	0.0000	3,747.9449	3,747.9449	1.0549		3,774.3174
Total	3.1651	31.4407	21.5650	0.0388	3.3074	1.5513	4.8588	0.5008	1.4411	1.9419	0.0000	3,747.9449	3,747.9449	1.0549		3,774.3174

Village South Specific Plan (Proposed) - Los Angeles-South Coast County, Summer

3.2 Demolition - 2021

Mitigated Construction Off-Site

	ROG	NOx	CO	SO2	Fugitive PM10	Exhaust PM10	PM10 Total	Fugitive PM2.5	Exhaust PM2.5	PM2.5 Total	Bio- CO2	NBio- CO2	Total CO2	CH4	N2O	CO2e
Category	lb/day										lb/day					
Hauling	0.1273	4.0952	0.9602	0.0119	0.2669	0.0126	0.2795	0.0732	0.0120	0.0852		1,292.2413	1,292.2413	0.0877		1,294.4337
Vendor	0.0000	0.0000	0.0000	0.0000	0.0000	0.0000	0.0000	0.0000	0.0000	0.0000		0.0000	0.0000	0.0000		0.0000
Worker	0.0487	0.0313	0.4282	1.1800e-003	0.1141	9.5000e-004	0.1151	0.0303	8.8000e-004	0.0311		117.2799	117.2799	3.5200e-003		117.3678
Total	0.1760	4.1265	1.3884	0.0131	0.3810	0.0135	0.3946	0.1034	0.0129	0.1163		1,409.5212	1,409.5212	0.0912		1,411.8015

3.3 Site Preparation - 2021

Unmitigated Construction On-Site

	ROG	NOx	CO	SO2	Fugitive PM10	Exhaust PM10	PM10 Total	Fugitive PM2.5	Exhaust PM2.5	PM2.5 Total	Bio- CO2	NBio- CO2	Total CO2	CH4	N2O	CO2e
Category	lb/day										lb/day					
Fugitive Dust					18.0663	0.0000	18.0663	9.9307	0.0000	9.9307			0.0000			0.0000
Off-Road	3.8882	40.4971	21.1543	0.0380		2.0445	2.0445		1.8809	1.8809		3,685.6569	3,685.6569	1.1920		3,715.4573
Total	3.8882	40.4971	21.1543	0.0380	18.0663	2.0445	20.1107	9.9307	1.8809	11.8116		3,685.6569	3,685.6569	1.1920		3,715.4573

Village South Specific Plan (Proposed) - Los Angeles-South Coast County, Summer

3.3 Site Preparation - 2021

Unmitigated Construction Off-Site

	ROG	NOx	CO	SO2	Fugitive PM10	Exhaust PM10	PM10 Total	Fugitive PM2.5	Exhaust PM2.5	PM2.5 Total	Bio- CO2	NBio- CO2	Total CO2	CH4	N2O	CO2e
Category	lb/day										lb/day					
Hauling	0.0000	0.0000	0.0000	0.0000	0.0000	0.0000	0.0000	0.0000	0.0000	0.0000		0.0000	0.0000	0.0000		0.0000
Vendor	0.0000	0.0000	0.0000	0.0000	0.0000	0.0000	0.0000	0.0000	0.0000	0.0000		0.0000	0.0000	0.0000		0.0000
Worker	0.0584	0.0375	0.5139	1.4100e-003	0.1369	1.1400e-003	0.1381	0.0363	1.0500e-003	0.0374		140.7359	140.7359	4.2200e-003		140.8414
Total	0.0584	0.0375	0.5139	1.4100e-003	0.1369	1.1400e-003	0.1381	0.0363	1.0500e-003	0.0374		140.7359	140.7359	4.2200e-003		140.8414

Mitigated Construction On-Site

	ROG	NOx	CO	SO2	Fugitive PM10	Exhaust PM10	PM10 Total	Fugitive PM2.5	Exhaust PM2.5	PM2.5 Total	Bio- CO2	NBio- CO2	Total CO2	CH4	N2O	CO2e
Category	lb/day										lb/day					
Fugitive Dust					18.0663	0.0000	18.0663	9.9307	0.0000	9.9307			0.0000			0.0000
Off-Road	3.8882	40.4971	21.1543	0.0380		2.0445	2.0445		1.8809	1.8809	0.0000	3,685.6569	3,685.6569	1.1920		3,715.4573
Total	3.8882	40.4971	21.1543	0.0380	18.0663	2.0445	20.1107	9.9307	1.8809	11.8116	0.0000	3,685.6569	3,685.6569	1.1920		3,715.4573

Village South Specific Plan (Proposed) - Los Angeles-South Coast County, Summer

3.3 Site Preparation - 2021

Mitigated Construction Off-Site

	ROG	NOx	CO	SO2	Fugitive PM10	Exhaust PM10	PM10 Total	Fugitive PM2.5	Exhaust PM2.5	PM2.5 Total	Bio- CO2	NBio- CO2	Total CO2	CH4	N2O	CO2e
Category	lb/day										lb/day					
Hauling	0.0000	0.0000	0.0000	0.0000	0.0000	0.0000	0.0000	0.0000	0.0000	0.0000		0.0000	0.0000	0.0000		0.0000
Vendor	0.0000	0.0000	0.0000	0.0000	0.0000	0.0000	0.0000	0.0000	0.0000	0.0000		0.0000	0.0000	0.0000		0.0000
Worker	0.0584	0.0375	0.5139	1.4100e-003	0.1369	1.1400e-003	0.1381	0.0363	1.0500e-003	0.0374		140.7359	140.7359	4.2200e-003		140.8414
Total	0.0584	0.0375	0.5139	1.4100e-003	0.1369	1.1400e-003	0.1381	0.0363	1.0500e-003	0.0374		140.7359	140.7359	4.2200e-003		140.8414

3.4 Grading - 2021

Unmitigated Construction On-Site

	ROG	NOx	CO	SO2	Fugitive PM10	Exhaust PM10	PM10 Total	Fugitive PM2.5	Exhaust PM2.5	PM2.5 Total	Bio- CO2	NBio- CO2	Total CO2	CH4	N2O	CO2e
Category	lb/day										lb/day					
Fugitive Dust					8.6733	0.0000	8.6733	3.5965	0.0000	3.5965			0.0000			0.0000
Off-Road	4.1912	46.3998	30.8785	0.0620		1.9853	1.9853		1.8265	1.8265		6,007.0434	6,007.0434	1.9428		6,055.6134
Total	4.1912	46.3998	30.8785	0.0620	8.6733	1.9853	10.6587	3.5965	1.8265	5.4230		6,007.0434	6,007.0434	1.9428		6,055.6134

Village South Specific Plan (Proposed) - Los Angeles-South Coast County, Summer

3.4 Grading - 2021

Unmitigated Construction Off-Site

	ROG	NOx	CO	SO2	Fugitive PM10	Exhaust PM10	PM10 Total	Fugitive PM2.5	Exhaust PM2.5	PM2.5 Total	Bio- CO2	NBio- CO2	Total CO2	CH4	N2O	CO2e
Category	lb/day										lb/day					
Hauling	0.0000	0.0000	0.0000	0.0000	0.0000	0.0000	0.0000	0.0000	0.0000	0.0000		0.0000	0.0000	0.0000		0.0000
Vendor	0.0000	0.0000	0.0000	0.0000	0.0000	0.0000	0.0000	0.0000	0.0000	0.0000		0.0000	0.0000	0.0000		0.0000
Worker	0.0649	0.0417	0.5710	1.5700e-003	0.1521	1.2700e-003	0.1534	0.0404	1.1700e-003	0.0415		156.3732	156.3732	4.6900e-003		156.4904
Total	0.0649	0.0417	0.5710	1.5700e-003	0.1521	1.2700e-003	0.1534	0.0404	1.1700e-003	0.0415		156.3732	156.3732	4.6900e-003		156.4904

Mitigated Construction On-Site

	ROG	NOx	CO	SO2	Fugitive PM10	Exhaust PM10	PM10 Total	Fugitive PM2.5	Exhaust PM2.5	PM2.5 Total	Bio- CO2	NBio- CO2	Total CO2	CH4	N2O	CO2e
Category	lb/day										lb/day					
Fugitive Dust					8.6733	0.0000	8.6733	3.5965	0.0000	3.5965			0.0000			0.0000
Off-Road	4.1912	46.3998	30.8785	0.0620		1.9853	1.9853		1.8265	1.8265	0.0000	6,007.0434	6,007.0434	1.9428		6,055.6134
Total	4.1912	46.3998	30.8785	0.0620	8.6733	1.9853	10.6587	3.5965	1.8265	5.4230	0.0000	6,007.0434	6,007.0434	1.9428		6,055.6134

Village South Specific Plan (Proposed) - Los Angeles-South Coast County, Summer

3.4 Grading - 2021

Mitigated Construction Off-Site

	ROG	NOx	CO	SO2	Fugitive PM10	Exhaust PM10	PM10 Total	Fugitive PM2.5	Exhaust PM2.5	PM2.5 Total	Bio- CO2	NBio- CO2	Total CO2	CH4	N2O	CO2e
Category	lb/day										lb/day					
Hauling	0.0000	0.0000	0.0000	0.0000	0.0000	0.0000	0.0000	0.0000	0.0000	0.0000		0.0000	0.0000	0.0000		0.0000
Vendor	0.0000	0.0000	0.0000	0.0000	0.0000	0.0000	0.0000	0.0000	0.0000	0.0000		0.0000	0.0000	0.0000		0.0000
Worker	0.0649	0.0417	0.5710	1.5700e-003	0.1521	1.2700e-003	0.1534	0.0404	1.1700e-003	0.0415		156.3732	156.3732	4.6900e-003		156.4904
Total	0.0649	0.0417	0.5710	1.5700e-003	0.1521	1.2700e-003	0.1534	0.0404	1.1700e-003	0.0415		156.3732	156.3732	4.6900e-003		156.4904

3.4 Grading - 2022

Unmitigated Construction On-Site

	ROG	NOx	CO	SO2	Fugitive PM10	Exhaust PM10	PM10 Total	Fugitive PM2.5	Exhaust PM2.5	PM2.5 Total	Bio- CO2	NBio- CO2	Total CO2	CH4	N2O	CO2e
Category	lb/day										lb/day					
Fugitive Dust					8.6733	0.0000	8.6733	3.5965	0.0000	3.5965			0.0000			0.0000
Off-Road	3.6248	38.8435	29.0415	0.0621		1.6349	1.6349		1.5041	1.5041		6,011.4105	6,011.4105	1.9442		6,060.0158
Total	3.6248	38.8435	29.0415	0.0621	8.6733	1.6349	10.3082	3.5965	1.5041	5.1006		6,011.4105	6,011.4105	1.9442		6,060.0158

Village South Specific Plan (Proposed) - Los Angeles-South Coast County, Summer

3.4 Grading - 2022

Unmitigated Construction Off-Site

	ROG	NOx	CO	SO2	Fugitive PM10	Exhaust PM10	PM10 Total	Fugitive PM2.5	Exhaust PM2.5	PM2.5 Total	Bio- CO2	NBio- CO2	Total CO2	CH4	N2O	CO2e
Category	lb/day										lb/day					
Hauling	0.0000	0.0000	0.0000	0.0000	0.0000	0.0000	0.0000	0.0000	0.0000	0.0000		0.0000	0.0000	0.0000		0.0000
Vendor	0.0000	0.0000	0.0000	0.0000	0.0000	0.0000	0.0000	0.0000	0.0000	0.0000		0.0000	0.0000	0.0000		0.0000
Worker	0.0607	0.0376	0.5263	1.5100e-003	0.1521	1.2300e-003	0.1534	0.0404	1.1300e-003	0.0415		150.8754	150.8754	4.2400e-003		150.9813
Total	0.0607	0.0376	0.5263	1.5100e-003	0.1521	1.2300e-003	0.1534	0.0404	1.1300e-003	0.0415		150.8754	150.8754	4.2400e-003		150.9813

Mitigated Construction On-Site

	ROG	NOx	CO	SO2	Fugitive PM10	Exhaust PM10	PM10 Total	Fugitive PM2.5	Exhaust PM2.5	PM2.5 Total	Bio- CO2	NBio- CO2	Total CO2	CH4	N2O	CO2e
Category	lb/day										lb/day					
Fugitive Dust					8.6733	0.0000	8.6733	3.5965	0.0000	3.5965			0.0000			0.0000
Off-Road	3.6248	38.8435	29.0415	0.0621		1.6349	1.6349		1.5041	1.5041	0.0000	6,011.4105	6,011.4105	1.9442		6,060.0158
Total	3.6248	38.8435	29.0415	0.0621	8.6733	1.6349	10.3082	3.5965	1.5041	5.1006	0.0000	6,011.4105	6,011.4105	1.9442		6,060.0158

Village South Specific Plan (Proposed) - Los Angeles-South Coast County, Summer

3.4 Grading - 2022

Mitigated Construction Off-Site

	ROG	NOx	CO	SO2	Fugitive PM10	Exhaust PM10	PM10 Total	Fugitive PM2.5	Exhaust PM2.5	PM2.5 Total	Bio- CO2	NBio- CO2	Total CO2	CH4	N2O	CO2e
Category	lb/day										lb/day					
Hauling	0.0000	0.0000	0.0000	0.0000	0.0000	0.0000	0.0000	0.0000	0.0000	0.0000		0.0000	0.0000	0.0000		0.0000
Vendor	0.0000	0.0000	0.0000	0.0000	0.0000	0.0000	0.0000	0.0000	0.0000	0.0000		0.0000	0.0000	0.0000		0.0000
Worker	0.0607	0.0376	0.5263	1.5100e-003	0.1521	1.2300e-003	0.1534	0.0404	1.1300e-003	0.0415		150.8754	150.8754	4.2400e-003		150.9813
Total	0.0607	0.0376	0.5263	1.5100e-003	0.1521	1.2300e-003	0.1534	0.0404	1.1300e-003	0.0415		150.8754	150.8754	4.2400e-003		150.9813

3.5 Building Construction - 2022

Unmitigated Construction On-Site

	ROG	NOx	CO	SO2	Fugitive PM10	Exhaust PM10	PM10 Total	Fugitive PM2.5	Exhaust PM2.5	PM2.5 Total	Bio- CO2	NBio- CO2	Total CO2	CH4	N2O	CO2e
Category	lb/day										lb/day					
Off-Road	1.7062	15.6156	16.3634	0.0269		0.8090	0.8090		0.7612	0.7612		2,554.3336	2,554.3336	0.6120		2,569.6322
Total	1.7062	15.6156	16.3634	0.0269		0.8090	0.8090		0.7612	0.7612		2,554.3336	2,554.3336	0.6120		2,569.6322

Village South Specific Plan (Proposed) - Los Angeles-South Coast County, Summer

3.5 Building Construction - 2022

Unmitigated Construction Off-Site

	ROG	NOx	CO	SO2	Fugitive PM10	Exhaust PM10	PM10 Total	Fugitive PM2.5	Exhaust PM2.5	PM2.5 Total	Bio- CO2	NBio- CO2	Total CO2	CH4	N2O	CO2e
Category	lb/day										lb/day					
Hauling	0.0000	0.0000	0.0000	0.0000	0.0000	0.0000	0.0000	0.0000	0.0000	0.0000		0.0000	0.0000	0.0000		0.0000
Vendor	0.4079	13.2032	3.4341	0.0364	0.9155	0.0248	0.9404	0.2636	0.0237	0.2873		3,896.548 2	3,896.548 2	0.2236		3,902.138 4
Worker	2.4299	1.5074	21.0801	0.0607	6.0932	0.0493	6.1425	1.6163	0.0454	1.6617		6,042.558 5	6,042.558 5	0.1697		6,046.800 0
Total	2.8378	14.7106	24.5142	0.0971	7.0087	0.0741	7.0828	1.8799	0.0691	1.9490		9,939.106 7	9,939.106 7	0.3933		9,948.938 4

Mitigated Construction On-Site

	ROG	NOx	CO	SO2	Fugitive PM10	Exhaust PM10	PM10 Total	Fugitive PM2.5	Exhaust PM2.5	PM2.5 Total	Bio- CO2	NBio- CO2	Total CO2	CH4	N2O	CO2e
Category	lb/day										lb/day					
Off-Road	1.7062	15.6156	16.3634	0.0269		0.8090	0.8090		0.7612	0.7612	0.0000	2,554.333 6	2,554.333 6	0.6120		2,569.632 2
Total	1.7062	15.6156	16.3634	0.0269		0.8090	0.8090		0.7612	0.7612	0.0000	2,554.333 6	2,554.333 6	0.6120		2,569.632 2

Village South Specific Plan (Proposed) - Los Angeles-South Coast County, Summer

3.5 Building Construction - 2022

Mitigated Construction Off-Site

	ROG	NOx	CO	SO2	Fugitive PM10	Exhaust PM10	PM10 Total	Fugitive PM2.5	Exhaust PM2.5	PM2.5 Total	Bio- CO2	NBio- CO2	Total CO2	CH4	N2O	CO2e
Category	lb/day										lb/day					
Hauling	0.0000	0.0000	0.0000	0.0000	0.0000	0.0000	0.0000	0.0000	0.0000	0.0000		0.0000	0.0000	0.0000		0.0000
Vendor	0.4079	13.2032	3.4341	0.0364	0.9155	0.0248	0.9404	0.2636	0.0237	0.2873		3,896.548 2	3,896.548 2	0.2236		3,902.138 4
Worker	2.4299	1.5074	21.0801	0.0607	6.0932	0.0493	6.1425	1.6163	0.0454	1.6617		6,042.558 5	6,042.558 5	0.1697		6,046.800 0
Total	2.8378	14.7106	24.5142	0.0971	7.0087	0.0741	7.0828	1.8799	0.0691	1.9490		9,939.106 7	9,939.106 7	0.3933		9,948.938 4

3.5 Building Construction - 2023

Unmitigated Construction On-Site

	ROG	NOx	CO	SO2	Fugitive PM10	Exhaust PM10	PM10 Total	Fugitive PM2.5	Exhaust PM2.5	PM2.5 Total	Bio- CO2	NBio- CO2	Total CO2	CH4	N2O	CO2e
Category	lb/day										lb/day					
Off-Road	1.5728	14.3849	16.2440	0.0269		0.6997	0.6997		0.6584	0.6584		2,555.209 9	2,555.209 9	0.6079		2,570.406 1
Total	1.5728	14.3849	16.2440	0.0269		0.6997	0.6997		0.6584	0.6584		2,555.209 9	2,555.209 9	0.6079		2,570.406 1

Village South Specific Plan (Proposed) - Los Angeles-South Coast County, Summer

3.5 Building Construction - 2023

Unmitigated Construction Off-Site

	ROG	NOx	CO	SO2	Fugitive PM10	Exhaust PM10	PM10 Total	Fugitive PM2.5	Exhaust PM2.5	PM2.5 Total	Bio- CO2	NBio- CO2	Total CO2	CH4	N2O	CO2e
Category	lb/day										lb/day					
Hauling	0.0000	0.0000	0.0000	0.0000	0.0000	0.0000	0.0000	0.0000	0.0000	0.0000		0.0000	0.0000	0.0000		0.0000
Vendor	0.3027	10.0181	3.1014	0.0352	0.9156	0.0116	0.9271	0.2636	0.0111	0.2747		3,773.876 2	3,773.876 2	0.1982		3,778.830 0
Worker	2.2780	1.3628	19.4002	0.0584	6.0932	0.0479	6.1411	1.6163	0.0441	1.6604		5,821.402 8	5,821.402 8	0.1529		5,825.225 4
Total	2.5807	11.3809	22.5017	0.0936	7.0088	0.0595	7.0682	1.8799	0.0552	1.9350		9,595.279 0	9,595.279 0	0.3511		9,604.055 4

Mitigated Construction On-Site

	ROG	NOx	CO	SO2	Fugitive PM10	Exhaust PM10	PM10 Total	Fugitive PM2.5	Exhaust PM2.5	PM2.5 Total	Bio- CO2	NBio- CO2	Total CO2	CH4	N2O	CO2e
Category	lb/day										lb/day					
Off-Road	1.5728	14.3849	16.2440	0.0269		0.6997	0.6997		0.6584	0.6584	0.0000	2,555.209 9	2,555.209 9	0.6079		2,570.406 1
Total	1.5728	14.3849	16.2440	0.0269		0.6997	0.6997		0.6584	0.6584	0.0000	2,555.209 9	2,555.209 9	0.6079		2,570.406 1

Village South Specific Plan (Proposed) - Los Angeles-South Coast County, Summer

3.5 Building Construction - 2023

Mitigated Construction Off-Site

	ROG	NOx	CO	SO2	Fugitive PM10	Exhaust PM10	PM10 Total	Fugitive PM2.5	Exhaust PM2.5	PM2.5 Total	Bio- CO2	NBio- CO2	Total CO2	CH4	N2O	CO2e
Category	lb/day										lb/day					
Hauling	0.0000	0.0000	0.0000	0.0000	0.0000	0.0000	0.0000	0.0000	0.0000	0.0000		0.0000	0.0000	0.0000		0.0000
Vendor	0.3027	10.0181	3.1014	0.0352	0.9156	0.0116	0.9271	0.2636	0.0111	0.2747		3,773.876 2	3,773.876 2	0.1982		3,778.830 0
Worker	2.2780	1.3628	19.4002	0.0584	6.0932	0.0479	6.1411	1.6163	0.0441	1.6604		5,821.402 8	5,821.402 8	0.1529		5,825.225 4
Total	2.5807	11.3809	22.5017	0.0936	7.0088	0.0595	7.0682	1.8799	0.0552	1.9350		9,595.279 0	9,595.279 0	0.3511		9,604.055 4

3.6 Paving - 2023

Unmitigated Construction On-Site

	ROG	NOx	CO	SO2	Fugitive PM10	Exhaust PM10	PM10 Total	Fugitive PM2.5	Exhaust PM2.5	PM2.5 Total	Bio- CO2	NBio- CO2	Total CO2	CH4	N2O	CO2e
Category	lb/day										lb/day					
Off-Road	1.0327	10.1917	14.5842	0.0228		0.5102	0.5102		0.4694	0.4694		2,207.584 1	2,207.584 1	0.7140		2,225.433 6
Paving	0.0000					0.0000	0.0000		0.0000	0.0000			0.0000			0.0000
Total	1.0327	10.1917	14.5842	0.0228		0.5102	0.5102		0.4694	0.4694		2,207.584 1	2,207.584 1	0.7140		2,225.433 6

Village South Specific Plan (Proposed) - Los Angeles-South Coast County, Summer

3.6 Paving - 2023

Unmitigated Construction Off-Site

	ROG	NOx	CO	SO2	Fugitive PM10	Exhaust PM10	PM10 Total	Fugitive PM2.5	Exhaust PM2.5	PM2.5 Total	Bio- CO2	NBio- CO2	Total CO2	CH4	N2O	CO2e
Category	lb/day										lb/day					
Hauling	0.0000	0.0000	0.0000	0.0000	0.0000	0.0000	0.0000	0.0000	0.0000	0.0000		0.0000	0.0000	0.0000		0.0000
Vendor	0.0000	0.0000	0.0000	0.0000	0.0000	0.0000	0.0000	0.0000	0.0000	0.0000		0.0000	0.0000	0.0000		0.0000
Worker	0.0427	0.0255	0.3633	1.0900e-003	0.1141	9.0000e-004	0.1150	0.0303	8.3000e-004	0.0311		109.0150	109.0150	2.8600e-003		109.0866
Total	0.0427	0.0255	0.3633	1.0900e-003	0.1141	9.0000e-004	0.1150	0.0303	8.3000e-004	0.0311		109.0150	109.0150	2.8600e-003		109.0866

Mitigated Construction On-Site

	ROG	NOx	CO	SO2	Fugitive PM10	Exhaust PM10	PM10 Total	Fugitive PM2.5	Exhaust PM2.5	PM2.5 Total	Bio- CO2	NBio- CO2	Total CO2	CH4	N2O	CO2e
Category	lb/day										lb/day					
Off-Road	1.0327	10.1917	14.5842	0.0228		0.5102	0.5102		0.4694	0.4694	0.0000	2,207.5841	2,207.5841	0.7140		2,225.4336
Paving	0.0000					0.0000	0.0000		0.0000	0.0000			0.0000			0.0000
Total	1.0327	10.1917	14.5842	0.0228		0.5102	0.5102		0.4694	0.4694	0.0000	2,207.5841	2,207.5841	0.7140		2,225.4336

Village South Specific Plan (Proposed) - Los Angeles-South Coast County, Summer

3.6 Paving - 2023

Mitigated Construction Off-Site

	ROG	NOx	CO	SO2	Fugitive PM10	Exhaust PM10	PM10 Total	Fugitive PM2.5	Exhaust PM2.5	PM2.5 Total	Bio- CO2	NBio- CO2	Total CO2	CH4	N2O	CO2e
Category	lb/day										lb/day					
Hauling	0.0000	0.0000	0.0000	0.0000	0.0000	0.0000	0.0000	0.0000	0.0000	0.0000		0.0000	0.0000	0.0000		0.0000
Vendor	0.0000	0.0000	0.0000	0.0000	0.0000	0.0000	0.0000	0.0000	0.0000	0.0000		0.0000	0.0000	0.0000		0.0000
Worker	0.0427	0.0255	0.3633	1.0900e-003	0.1141	9.0000e-004	0.1150	0.0303	8.3000e-004	0.0311		109.0150	109.0150	2.8600e-003		109.0866
Total	0.0427	0.0255	0.3633	1.0900e-003	0.1141	9.0000e-004	0.1150	0.0303	8.3000e-004	0.0311		109.0150	109.0150	2.8600e-003		109.0866

3.6 Paving - 2024

Unmitigated Construction On-Site

	ROG	NOx	CO	SO2	Fugitive PM10	Exhaust PM10	PM10 Total	Fugitive PM2.5	Exhaust PM2.5	PM2.5 Total	Bio- CO2	NBio- CO2	Total CO2	CH4	N2O	CO2e
Category	lb/day										lb/day					
Off-Road	0.9882	9.5246	14.6258	0.0228		0.4685	0.4685		0.4310	0.4310		2,207.5472	2,207.5472	0.7140		2,225.3963
Paving	0.0000					0.0000	0.0000		0.0000	0.0000			0.0000			0.0000
Total	0.9882	9.5246	14.6258	0.0228		0.4685	0.4685		0.4310	0.4310		2,207.5472	2,207.5472	0.7140		2,225.3963

Village South Specific Plan (Proposed) - Los Angeles-South Coast County, Summer

3.6 Paving - 2024

Unmitigated Construction Off-Site

	ROG	NOx	CO	SO2	Fugitive PM10	Exhaust PM10	PM10 Total	Fugitive PM2.5	Exhaust PM2.5	PM2.5 Total	Bio- CO2	NBio- CO2	Total CO2	CH4	N2O	CO2e
Category	lb/day										lb/day					
Hauling	0.0000	0.0000	0.0000	0.0000	0.0000	0.0000	0.0000	0.0000	0.0000	0.0000		0.0000	0.0000	0.0000		0.0000
Vendor	0.0000	0.0000	0.0000	0.0000	0.0000	0.0000	0.0000	0.0000	0.0000	0.0000		0.0000	0.0000	0.0000		0.0000
Worker	0.0403	0.0233	0.3384	1.0600e-003	0.1141	8.8000e-004	0.1150	0.0303	8.1000e-004	0.0311		105.6336	105.6336	2.6300e-003		105.6992
Total	0.0403	0.0233	0.3384	1.0600e-003	0.1141	8.8000e-004	0.1150	0.0303	8.1000e-004	0.0311		105.6336	105.6336	2.6300e-003		105.6992

Mitigated Construction On-Site

	ROG	NOx	CO	SO2	Fugitive PM10	Exhaust PM10	PM10 Total	Fugitive PM2.5	Exhaust PM2.5	PM2.5 Total	Bio- CO2	NBio- CO2	Total CO2	CH4	N2O	CO2e
Category	lb/day										lb/day					
Off-Road	0.9882	9.5246	14.6258	0.0228		0.4685	0.4685		0.4310	0.4310	0.0000	2,207.5472	2,207.5472	0.7140		2,225.3963
Paving	0.0000					0.0000	0.0000		0.0000	0.0000			0.0000			0.0000
Total	0.9882	9.5246	14.6258	0.0228		0.4685	0.4685		0.4310	0.4310	0.0000	2,207.5472	2,207.5472	0.7140		2,225.3963

Village South Specific Plan (Proposed) - Los Angeles-South Coast County, Summer

3.6 Paving - 2024

Mitigated Construction Off-Site

	ROG	NOx	CO	SO2	Fugitive PM10	Exhaust PM10	PM10 Total	Fugitive PM2.5	Exhaust PM2.5	PM2.5 Total	Bio- CO2	NBio- CO2	Total CO2	CH4	N2O	CO2e
Category	lb/day										lb/day					
Hauling	0.0000	0.0000	0.0000	0.0000	0.0000	0.0000	0.0000	0.0000	0.0000	0.0000		0.0000	0.0000	0.0000		0.0000
Vendor	0.0000	0.0000	0.0000	0.0000	0.0000	0.0000	0.0000	0.0000	0.0000	0.0000		0.0000	0.0000	0.0000		0.0000
Worker	0.0403	0.0233	0.3384	1.0600e-003	0.1141	8.8000e-004	0.1150	0.0303	8.1000e-004	0.0311		105.6336	105.6336	2.6300e-003		105.6992
Total	0.0403	0.0233	0.3384	1.0600e-003	0.1141	8.8000e-004	0.1150	0.0303	8.1000e-004	0.0311		105.6336	105.6336	2.6300e-003		105.6992

3.7 Architectural Coating - 2024

Unmitigated Construction On-Site

	ROG	NOx	CO	SO2	Fugitive PM10	Exhaust PM10	PM10 Total	Fugitive PM2.5	Exhaust PM2.5	PM2.5 Total	Bio- CO2	NBio- CO2	Total CO2	CH4	N2O	CO2e
Category	lb/day										lb/day					
Archit. Coating	236.4115					0.0000	0.0000		0.0000	0.0000			0.0000			0.0000
Off-Road	0.1808	1.2188	1.8101	2.9700e-003		0.0609	0.0609		0.0609	0.0609		281.4481	281.4481	0.0159		281.8443
Total	236.5923	1.2188	1.8101	2.9700e-003		0.0609	0.0609		0.0609	0.0609		281.4481	281.4481	0.0159		281.8443

Village South Specific Plan (Proposed) - Los Angeles-South Coast County, Summer

3.7 Architectural Coating - 2024

Unmitigated Construction Off-Site

	ROG	NOx	CO	SO2	Fugitive PM10	Exhaust PM10	PM10 Total	Fugitive PM2.5	Exhaust PM2.5	PM2.5 Total	Bio- CO2	NBio- CO2	Total CO2	CH4	N2O	CO2e
Category	lb/day										lb/day					
Hauling	0.0000	0.0000	0.0000	0.0000	0.0000	0.0000	0.0000	0.0000	0.0000	0.0000		0.0000	0.0000	0.0000		0.0000
Vendor	0.0000	0.0000	0.0000	0.0000	0.0000	0.0000	0.0000	0.0000	0.0000	0.0000		0.0000	0.0000	0.0000		0.0000
Worker	0.4296	0.2481	3.6098	0.0113	1.2171	9.4300e-003	1.2266	0.3229	8.6800e-003	0.3315		1,126.7583	1,126.7583	0.0280		1,127.4583
Total	0.4296	0.2481	3.6098	0.0113	1.2171	9.4300e-003	1.2266	0.3229	8.6800e-003	0.3315		1,126.7583	1,126.7583	0.0280		1,127.4583

Mitigated Construction On-Site

	ROG	NOx	CO	SO2	Fugitive PM10	Exhaust PM10	PM10 Total	Fugitive PM2.5	Exhaust PM2.5	PM2.5 Total	Bio- CO2	NBio- CO2	Total CO2	CH4	N2O	CO2e
Category	lb/day										lb/day					
Archit. Coating	236.4115					0.0000	0.0000		0.0000	0.0000			0.0000			0.0000
Off-Road	0.1808	1.2188	1.8101	2.9700e-003		0.0609	0.0609		0.0609	0.0609	0.0000	281.4481	281.4481	0.0159		281.8443
Total	236.5923	1.2188	1.8101	2.9700e-003		0.0609	0.0609		0.0609	0.0609	0.0000	281.4481	281.4481	0.0159		281.8443

Village South Specific Plan (Proposed) - Los Angeles-South Coast County, Summer

3.7 Architectural Coating - 2024

Mitigated Construction Off-Site

	ROG	NOx	CO	SO2	Fugitive PM10	Exhaust PM10	PM10 Total	Fugitive PM2.5	Exhaust PM2.5	PM2.5 Total	Bio- CO2	NBio- CO2	Total CO2	CH4	N2O	CO2e
Category	lb/day										lb/day					
Hauling	0.0000	0.0000	0.0000	0.0000	0.0000	0.0000	0.0000	0.0000	0.0000	0.0000		0.0000	0.0000	0.0000		0.0000
Vendor	0.0000	0.0000	0.0000	0.0000	0.0000	0.0000	0.0000	0.0000	0.0000	0.0000		0.0000	0.0000	0.0000		0.0000
Worker	0.4296	0.2481	3.6098	0.0113	1.2171	9.4300e-003	1.2266	0.3229	8.6800e-003	0.3315		1,126.7583	1,126.7583	0.0280		1,127.4583
Total	0.4296	0.2481	3.6098	0.0113	1.2171	9.4300e-003	1.2266	0.3229	8.6800e-003	0.3315		1,126.7583	1,126.7583	0.0280		1,127.4583

4.0 Operational Detail - Mobile

4.1 Mitigation Measures Mobile

Village South Specific Plan (Proposed) - Los Angeles-South Coast County, Summer

	ROG	NOx	CO	SO2	Fugitive PM10	Exhaust PM10	PM10 Total	Fugitive PM2.5	Exhaust PM2.5	PM2.5 Total	Bio- CO2	NBio- CO2	Total CO2	CH4	N2O	CO2e
Category	lb/day										lb/day					
Mitigated	9.8489	45.4304	114.8495	0.4917	45.9592	0.3360	46.2951	12.2950	0.3119	12.6070		50,306.60 34	50,306.60 34	2.1807		50,361.12 08
Unmitigated	9.8489	45.4304	114.8495	0.4917	45.9592	0.3360	46.2951	12.2950	0.3119	12.6070		50,306.60 34	50,306.60 34	2.1807		50,361.12 08

4.2 Trip Summary Information

Land Use	Average Daily Trip Rate			Unmitigated	Mitigated
	Weekday	Saturday	Sunday	Annual VMT	Annual VMT
Apartments Low Rise	145.75	154.25	154.00	506,227	506,227
Apartments Mid Rise	4,026.75	3,773.25	4075.50	13,660,065	13,660,065
General Office Building	288.45	62.55	31.05	706,812	706,812
High Turnover (Sit Down Restaurant)	2,368.80	2,873.52	2817.72	3,413,937	3,413,937
Hotel	192.00	187.50	160.00	445,703	445,703
Quality Restaurant	501.12	511.92	461.20	707,488	707,488
Regional Shopping Center	528.08	601.44	357.84	1,112,221	1,112,221
Total	8,050.95	8,164.43	8,057.31	20,552,452	20,552,452

4.3 Trip Type Information

Village South Specific Plan (Proposed) - Los Angeles-South Coast County, Summer

Land Use	Miles			Trip %			Trip Purpose %		
	H-W or C-W	H-S or C-C	H-O or C-NW	H-W or C-W	H-S or C-C	H-O or C-NW	Primary	Diverted	Pass-by
Apartments Low Rise	14.70	5.90	8.70	40.20	19.20	40.60	86	11	3
Apartments Mid Rise	14.70	5.90	8.70	40.20	19.20	40.60	86	11	3
General Office Building	16.60	8.40	6.90	33.00	48.00	19.00	77	19	4
High Turnover (Sit Down Restaurant)	16.60	8.40	6.90	8.50	72.50	19.00	37	20	43
Hotel	16.60	8.40	6.90	19.40	61.60	19.00	58	38	4
Quality Restaurant	16.60	8.40	6.90	12.00	69.00	19.00	38	18	44
Regional Shopping Center	16.60	8.40	6.90	16.30	64.70	19.00	54	35	11

4.4 Fleet Mix

Land Use	LDA	LDT1	LDT2	MDV	LHD1	LHD2	MHD	HHD	OBUS	UBUS	MCY	SBUS	MH
Apartments Low Rise	0.543088	0.044216	0.209971	0.116369	0.014033	0.006332	0.021166	0.033577	0.002613	0.001817	0.005285	0.000712	0.000821
Apartments Mid Rise	0.543088	0.044216	0.209971	0.116369	0.014033	0.006332	0.021166	0.033577	0.002613	0.001817	0.005285	0.000712	0.000821
General Office Building	0.543088	0.044216	0.209971	0.116369	0.014033	0.006332	0.021166	0.033577	0.002613	0.001817	0.005285	0.000712	0.000821
High Turnover (Sit Down Restaurant)	0.543088	0.044216	0.209971	0.116369	0.014033	0.006332	0.021166	0.033577	0.002613	0.001817	0.005285	0.000712	0.000821
Hotel	0.543088	0.044216	0.209971	0.116369	0.014033	0.006332	0.021166	0.033577	0.002613	0.001817	0.005285	0.000712	0.000821
Quality Restaurant	0.543088	0.044216	0.209971	0.116369	0.014033	0.006332	0.021166	0.033577	0.002613	0.001817	0.005285	0.000712	0.000821
Regional Shopping Center	0.543088	0.044216	0.209971	0.116369	0.014033	0.006332	0.021166	0.033577	0.002613	0.001817	0.005285	0.000712	0.000821

5.0 Energy Detail

Historical Energy Use: N

5.1 Mitigation Measures Energy

Village South Specific Plan (Proposed) - Los Angeles-South Coast County, Summer

	ROG	NOx	CO	SO2	Fugitive PM10	Exhaust PM10	PM10 Total	Fugitive PM2.5	Exhaust PM2.5	PM2.5 Total	Bio- CO2	NBio- CO2	Total CO2	CH4	N2O	CO2e
Category	lb/day										lb/day					
NaturalGas Mitigated	0.7660	6.7462	4.2573	0.0418		0.5292	0.5292		0.5292	0.5292		8,355.983 2	8,355.983 2	0.1602	0.1532	8,405.638 7
NaturalGas Unmitigated	0.7660	6.7462	4.2573	0.0418		0.5292	0.5292		0.5292	0.5292		8,355.983 2	8,355.983 2	0.1602	0.1532	8,405.638 7

Village South Specific Plan (Proposed) - Los Angeles-South Coast County, Summer

5.2 Energy by Land Use - NaturalGas

Unmitigated

	NaturalGas Use	ROG	NOx	CO	SO2	Fugitive PM10	Exhaust PM10	PM10 Total	Fugitive PM2.5	Exhaust PM2.5	PM2.5 Total	Bio- CO2	NBio- CO2	Total CO2	CH4	N2O	CO2e
Land Use	kBTU/yr	lb/day										lb/day					
Apartments Low Rise	1119.16	0.0121	0.1031	0.0439	6.6000e-004		8.3400e-003	8.3400e-003		8.3400e-003	8.3400e-003		131.6662	131.6662	2.5200e-003	2.4100e-003	132.4486
Apartments Mid Rise	35784.3	0.3859	3.2978	1.4033	0.0211		0.2666	0.2666		0.2666	0.2666		4,209.9164	4,209.9164	0.0807	0.0772	4,234.9339
General Office Building	1283.42	0.0138	0.1258	0.1057	7.5000e-004		9.5600e-003	9.5600e-003		9.5600e-003	9.5600e-003		150.9911	150.9911	2.8900e-003	2.7700e-003	151.8884
High Turnover (Sit Down Restaurant)	22759.9	0.2455	2.2314	1.8743	0.0134		0.1696	0.1696		0.1696	0.1696		2,677.6342	2,677.6342	0.0513	0.0491	2,693.5460
Hotel	4769.72	0.0514	0.4676	0.3928	2.8100e-003		0.0355	0.0355		0.0355	0.0355		561.1436	561.1436	0.0108	0.0103	564.4782
Quality Restaurant	5057.75	0.0545	0.4959	0.4165	2.9800e-003		0.0377	0.0377		0.0377	0.0377		595.0298	595.0298	0.0114	0.0109	598.5658
Regional Shopping Center	251.616	2.7100e-003	0.0247	0.0207	1.5000e-004		1.8700e-003	1.8700e-003		1.8700e-003	1.8700e-003		29.6019	29.6019	5.7000e-004	5.4000e-004	29.7778
Total		0.7660	6.7463	4.2573	0.0418		0.5292	0.5292		0.5292	0.5292		8,355.9832	8,355.9832	0.1602	0.1532	8,405.6387

Village South Specific Plan (Proposed) - Los Angeles-South Coast County, Summer

5.2 Energy by Land Use - NaturalGas

Mitigated

	NaturalGas Use	ROG	NOx	CO	SO2	Fugitive PM10	Exhaust PM10	PM10 Total	Fugitive PM2.5	Exhaust PM2.5	PM2.5 Total	Bio- CO2	NBio- CO2	Total CO2	CH4	N2O	CO2e
Land Use	kBTU/yr	lb/day										lb/day					
Apartments Low Rise	1.11916	0.0121	0.1031	0.0439	6.6000e-004		8.3400e-003	8.3400e-003		8.3400e-003	8.3400e-003		131.6662	131.6662	2.5200e-003	2.4100e-003	132.4486
Apartments Mid Rise	35.7843	0.3859	3.2978	1.4033	0.0211		0.2666	0.2666		0.2666	0.2666		4,209.9164	4,209.9164	0.0807	0.0772	4,234.9339
General Office Building	1.28342	0.0138	0.1258	0.1057	7.5000e-004		9.5600e-003	9.5600e-003		9.5600e-003	9.5600e-003		150.9911	150.9911	2.8900e-003	2.7700e-003	151.8884
High Turnover (Sit Down Restaurant)	22.7599	0.2455	2.2314	1.8743	0.0134		0.1696	0.1696		0.1696	0.1696		2,677.6342	2,677.6342	0.0513	0.0491	2,693.5460
Hotel	4.76972	0.0514	0.4676	0.3928	2.8100e-003		0.0355	0.0355		0.0355	0.0355		561.1436	561.1436	0.0108	0.0103	564.4782
Quality Restaurant	5.05775	0.0545	0.4959	0.4165	2.9800e-003		0.0377	0.0377		0.0377	0.0377		595.0298	595.0298	0.0114	0.0109	598.5658
Regional Shopping Center	0.251616	2.7100e-003	0.0247	0.0207	1.5000e-004		1.8700e-003	1.8700e-003		1.8700e-003	1.8700e-003		29.6019	29.6019	5.7000e-004	5.4000e-004	29.7778
Total		0.7660	6.7463	4.2573	0.0418		0.5292	0.5292		0.5292	0.5292		8,355.9832	8,355.9832	0.1602	0.1532	8,405.6387

6.0 Area Detail

6.1 Mitigation Measures Area

Village South Specific Plan (Proposed) - Los Angeles-South Coast County, Summer

	ROG	NOx	CO	SO2	Fugitive PM10	Exhaust PM10	PM10 Total	Fugitive PM2.5	Exhaust PM2.5	PM2.5 Total	Bio- CO2	NBio- CO2	Total CO2	CH4	N2O	CO2e
Category	lb/day										lb/day					
Mitigated	30.5020	15.0496	88.4430	0.0944		1.5974	1.5974		1.5974	1.5974	0.0000	18,148.5950	18,148.5950	0.4874	0.3300	18,259.1192
Unmitigated	30.5020	15.0496	88.4430	0.0944		1.5974	1.5974		1.5974	1.5974	0.0000	18,148.5950	18,148.5950	0.4874	0.3300	18,259.1192

6.2 Area by SubCategory

Unmitigated

	ROG	NOx	CO	SO2	Fugitive PM10	Exhaust PM10	PM10 Total	Fugitive PM2.5	Exhaust PM2.5	PM2.5 Total	Bio- CO2	NBio- CO2	Total CO2	CH4	N2O	CO2e
SubCategory	lb/day										lb/day					
Architectural Coating	2.2670					0.0000	0.0000		0.0000	0.0000			0.0000			0.0000
Consumer Products	24.1085					0.0000	0.0000		0.0000	0.0000			0.0000			0.0000
Hearth	1.6500	14.1000	6.0000	0.0900		1.1400	1.1400		1.1400	1.1400	0.0000	18,000.0000	18,000.0000	0.3450	0.3300	18,106.9650
Landscaping	2.4766	0.9496	82.4430	4.3600e-003		0.4574	0.4574		0.4574	0.4574		148.5950	148.5950	0.1424		152.1542
Total	30.5020	15.0496	88.4430	0.0944		1.5974	1.5974		1.5974	1.5974	0.0000	18,148.5950	18,148.5950	0.4874	0.3300	18,259.1192

Village South Specific Plan (Proposed) - Los Angeles-South Coast County, Summer

6.2 Area by SubCategory

Mitigated

	ROG	NOx	CO	SO2	Fugitive PM10	Exhaust PM10	PM10 Total	Fugitive PM2.5	Exhaust PM2.5	PM2.5 Total	Bio- CO2	NBio- CO2	Total CO2	CH4	N2O	CO2e
SubCategory	lb/day										lb/day					
Architectural Coating	2.2670					0.0000	0.0000		0.0000	0.0000			0.0000			0.0000
Consumer Products	24.1085					0.0000	0.0000		0.0000	0.0000			0.0000			0.0000
Hearth	1.6500	14.1000	6.0000	0.0900		1.1400	1.1400		1.1400	1.1400	0.0000	18,000.0000	18,000.0000	0.3450	0.3300	18,106.9650
Landscaping	2.4766	0.9496	82.4430	4.3600e-003		0.4574	0.4574		0.4574	0.4574		148.5950	148.5950	0.1424		152.1542
Total	30.5020	15.0496	88.4430	0.0944		1.5974	1.5974		1.5974	1.5974	0.0000	18,148.5950	18,148.5950	0.4874	0.3300	18,259.1192

7.0 Water Detail

7.1 Mitigation Measures Water

8.0 Waste Detail

8.1 Mitigation Measures Waste

9.0 Operational Offroad

Equipment Type	Number	Hours/Day	Days/Year	Horse Power	Load Factor	Fuel Type
----------------	--------	-----------	-----------	-------------	-------------	-----------

10.0 Stationary Equipment

Village South Specific Plan (Proposed) - Los Angeles-South Coast County, Summer

Fire Pumps and Emergency Generators

Equipment Type	Number	Hours/Day	Hours/Year	Horse Power	Load Factor	Fuel Type
----------------	--------	-----------	------------	-------------	-------------	-----------

Boilers

Equipment Type	Number	Heat Input/Day	Heat Input/Year	Boiler Rating	Fuel Type
----------------	--------	----------------	-----------------	---------------	-----------

User Defined Equipment

Equipment Type	Number
----------------	--------

11.0 Vegetation

Village South Specific Plan (Proposed) - Los Angeles-South Coast County, Winter

Village South Specific Plan (Proposed)
Los Angeles-South Coast County, Winter

1.0 Project Characteristics

1.1 Land Usage

Land Uses	Size	Metric	Lot Acreage	Floor Surface Area	Population
General Office Building	45.00	1000sqft	1.03	45,000.00	0
High Turnover (Sit Down Restaurant)	36.00	1000sqft	0.83	36,000.00	0
Hotel	50.00	Room	1.67	72,600.00	0
Quality Restaurant	8.00	1000sqft	0.18	8,000.00	0
Apartments Low Rise	25.00	Dwelling Unit	1.56	25,000.00	72
Apartments Mid Rise	975.00	Dwelling Unit	25.66	975,000.00	2789
Regional Shopping Center	56.00	1000sqft	1.29	56,000.00	0

1.2 Other Project Characteristics

Urbanization	Urban	Wind Speed (m/s)	2.2	Precipitation Freq (Days)	33
Climate Zone	9			Operational Year	2028
Utility Company	Southern California Edison				
CO2 Intensity (lb/MW hr)	702.44	CH4 Intensity (lb/MW hr)	0.029	N2O Intensity (lb/MW hr)	0.006

1.3 User Entered Comments & Non-Default Data

Village South Specific Plan (Proposed) - Los Angeles-South Coast County, Winter

Project Characteristics - Consistent with the DEIR's model.

Land Use - See SWAPE comment regarding residential and retail land uses.

Construction Phase - See SWAPE comment regarding individual construction phase lengths.

Demolition - Consistent with the DEIR's model. See SWAPE comment regarding demolition.

Vehicle Trips - Saturday trips consistent with the DEIR's model. See SWAPE comment regarding weekday and Sunday trips.

Woodstoves - Woodstoves and wood-burning fireplaces consistent with the DEIR's model. See SWAPE comment regarding gas fireplaces.

Energy Use -

Construction Off-road Equipment Mitigation - See SWAPE comment on construction-related mitigation.

Area Mitigation - See SWAPE comment regarding operational mitigation measures.

Water Mitigation - See SWAPE comment regarding operational mitigation measures.

Trips and VMT - Local hire provision

Table Name	Column Name	Default Value	New Value
tblFireplaces	FireplaceWoodMass	1,019.20	0.00
tblFireplaces	FireplaceWoodMass	1,019.20	0.00
tblFireplaces	NumberWood	1.25	0.00
tblFireplaces	NumberWood	48.75	0.00
tblTripsAndVMT	WorkerTripLength	14.70	10.00
tblTripsAndVMT	WorkerTripLength	14.70	10.00
tblTripsAndVMT	WorkerTripLength	14.70	10.00
tblTripsAndVMT	WorkerTripLength	14.70	10.00
tblTripsAndVMT	WorkerTripLength	14.70	10.00
tblTripsAndVMT	WorkerTripLength	14.70	10.00
tblVehicleTrips	ST_TR	7.16	6.17
tblVehicleTrips	ST_TR	6.39	3.87
tblVehicleTrips	ST_TR	2.46	1.39
tblVehicleTrips	ST_TR	158.37	79.82

Village South Specific Plan (Proposed) - Los Angeles-South Coast County, Winter

tblVehicleTrips	ST_TR	8.19	3.75
tblVehicleTrips	ST_TR	94.36	63.99
tblVehicleTrips	ST_TR	49.97	10.74
tblVehicleTrips	SU_TR	6.07	6.16
tblVehicleTrips	SU_TR	5.86	4.18
tblVehicleTrips	SU_TR	1.05	0.69
tblVehicleTrips	SU_TR	131.84	78.27
tblVehicleTrips	SU_TR	5.95	3.20
tblVehicleTrips	SU_TR	72.16	57.65
tblVehicleTrips	SU_TR	25.24	6.39
tblVehicleTrips	WD_TR	6.59	5.83
tblVehicleTrips	WD_TR	6.65	4.13
tblVehicleTrips	WD_TR	11.03	6.41
tblVehicleTrips	WD_TR	127.15	65.80
tblVehicleTrips	WD_TR	8.17	3.84
tblVehicleTrips	WD_TR	89.95	62.64
tblVehicleTrips	WD_TR	42.70	9.43
tblWoodstoves	NumberCatalytic	1.25	0.00
tblWoodstoves	NumberCatalytic	48.75	0.00
tblWoodstoves	NumberNoncatalytic	1.25	0.00
tblWoodstoves	NumberNoncatalytic	48.75	0.00
tblWoodstoves	WoodstoveDayYear	25.00	0.00
tblWoodstoves	WoodstoveDayYear	25.00	0.00
tblWoodstoves	WoodstoveWoodMass	999.60	0.00
tblWoodstoves	WoodstoveWoodMass	999.60	0.00

2.0 Emissions Summary

Village South Specific Plan (Proposed) - Los Angeles-South Coast County, Winter

2.1 Overall Construction (Maximum Daily Emission)

Unmitigated Construction

	ROG	NOx	CO	SO2	Fugitive PM10	Exhaust PM10	PM10 Total	Fugitive PM2.5	Exhaust PM2.5	PM2.5 Total	Bio- CO2	NBio- CO2	Total CO2	CH4	N2O	CO2e
Year	lb/day										lb/day					
2021	4.2621	46.4460	31.4068	0.0635	18.2032	2.0456	20.2488	9.9670	1.8820	11.8490	0.0000	6,154.3377	6,154.3377	1.9472	0.0000	6,203.0186
2022	4.7966	38.8851	39.6338	0.1195	8.8255	1.6361	10.4616	3.6369	1.5052	5.1421	0.0000	12,035.3440	12,035.3440	1.9482	0.0000	12,060.6013
2023	4.3939	25.8648	37.5031	0.1162	7.0088	0.7598	7.7685	1.8799	0.7142	2.5940	0.0000	11,710.4080	11,710.4080	0.9617	0.0000	11,734.4497
2024	237.0656	9.5503	14.9372	0.0238	1.2171	0.4694	1.2875	0.3229	0.4319	0.4621	0.0000	2,307.0517	2,307.0517	0.7164	0.0000	2,324.9627
Maximum	237.0656	46.4460	39.6338	0.1195	18.2032	2.0456	20.2488	9.9670	1.8820	11.8490	0.0000	12,035.3440	12,035.3440	1.9482	0.0000	12,060.6013

Village South Specific Plan (Proposed) - Los Angeles-South Coast County, Winter

2.2 Overall Operational

Unmitigated Operational

	ROG	NOx	CO	SO2	Fugitive PM10	Exhaust PM10	PM10 Total	Fugitive PM2.5	Exhaust PM2.5	PM2.5 Total	Bio- CO2	NBio- CO2	Total CO2	CH4	N2O	CO2e
Category	lb/day										lb/day					
Area	30.5020	15.0496	88.4430	0.0944		1.5974	1.5974		1.5974	1.5974	0.0000	18,148.5950	18,148.5950	0.4874	0.3300	18,259.1192
Energy	0.7660	6.7462	4.2573	0.0418		0.5292	0.5292		0.5292	0.5292		8,355.9832	8,355.9832	0.1602	0.1532	8,405.6387
Mobile	9.5233	45.9914	110.0422	0.4681	45.9592	0.3373	46.2965	12.2950	0.3132	12.6083		47,917.8005	47,917.8005	2.1953		47,972.6839
Total	40.7912	67.7872	202.7424	0.6043	45.9592	2.4640	48.4231	12.2950	2.4399	14.7349	0.0000	74,422.3787	74,422.3787	2.8429	0.4832	74,637.4417

Mitigated Operational

	ROG	NOx	CO	SO2	Fugitive PM10	Exhaust PM10	PM10 Total	Fugitive PM2.5	Exhaust PM2.5	PM2.5 Total	Bio- CO2	NBio- CO2	Total CO2	CH4	N2O	CO2e
Category	lb/day										lb/day					
Area	30.5020	15.0496	88.4430	0.0944		1.5974	1.5974		1.5974	1.5974	0.0000	18,148.5950	18,148.5950	0.4874	0.3300	18,259.1192
Energy	0.7660	6.7462	4.2573	0.0418		0.5292	0.5292		0.5292	0.5292		8,355.9832	8,355.9832	0.1602	0.1532	8,405.6387
Mobile	9.5233	45.9914	110.0422	0.4681	45.9592	0.3373	46.2965	12.2950	0.3132	12.6083		47,917.8005	47,917.8005	2.1953		47,972.6839
Total	40.7912	67.7872	202.7424	0.6043	45.9592	2.4640	48.4231	12.2950	2.4399	14.7349	0.0000	74,422.3787	74,422.3787	2.8429	0.4832	74,637.4417

Village South Specific Plan (Proposed) - Los Angeles-South Coast County, Winter

	ROG	NOx	CO	SO2	Fugitive PM10	Exhaust PM10	PM10 Total	Fugitive PM2.5	Exhaust PM2.5	PM2.5 Total	Bio- CO2	NBio-CO2	Total CO2	CH4	N2O	CO2e
Percent Reduction	0.00	0.00	0.00	0.00	0.00	0.00	0.00	0.00	0.00	0.00	0.00	0.00	0.00	0.00	0.00	0.00

3.0 Construction Detail

Construction Phase

Phase Number	Phase Name	Phase Type	Start Date	End Date	Num Days Week	Num Days	Phase Description
1	Demolition	Demolition	9/1/2021	10/12/2021	5	30	
2	Site Preparation	Site Preparation	10/13/2021	11/9/2021	5	20	
3	Grading	Grading	11/10/2021	1/11/2022	5	45	
4	Building Construction	Building Construction	1/12/2022	12/12/2023	5	500	
5	Paving	Paving	12/13/2023	1/30/2024	5	35	
6	Architectural Coating	Architectural Coating	1/31/2024	3/19/2024	5	35	

Acres of Grading (Site Preparation Phase): 0

Acres of Grading (Grading Phase): 112.5

Acres of Paving: 0

Residential Indoor: 2,025,000; Residential Outdoor: 675,000; Non-Residential Indoor: 326,400; Non-Residential Outdoor: 108,800; Striped Parking Area: 0 (Architectural Coating – sqft)

OffRoad Equipment

Village South Specific Plan (Proposed) - Los Angeles-South Coast County, Winter

Phase Name	Offroad Equipment Type	Amount	Usage Hours	Horse Power	Load Factor
Demolition	Concrete/Industrial Saws	1	8.00	81	0.73
Demolition	Excavators	3	8.00	158	0.38
Demolition	Rubber Tired Dozers	2	8.00	247	0.40
Site Preparation	Rubber Tired Dozers	3	8.00	247	0.40
Site Preparation	Tractors/Loaders/Backhoes	4	8.00	97	0.37
Grading	Excavators	2	8.00	158	0.38
Grading	Graders	1	8.00	187	0.41
Grading	Rubber Tired Dozers	1	8.00	247	0.40
Grading	Scrapers	2	8.00	367	0.48
Grading	Tractors/Loaders/Backhoes	2	8.00	97	0.37
Building Construction	Cranes	1	7.00	231	0.29
Building Construction	Forklifts	3	8.00	89	0.20
Building Construction	Generator Sets	1	8.00	84	0.74
Building Construction	Tractors/Loaders/Backhoes	3	7.00	97	0.37
Building Construction	Welders	1	8.00	46	0.45
Paving	Pavers	2	8.00	130	0.42
Paving	Paving Equipment	2	8.00	132	0.36
Paving	Rollers	2	8.00	80	0.38
Architectural Coating	Air Compressors	1	6.00	78	0.48

Trips and VMT

Village South Specific Plan (Proposed) - Los Angeles-South Coast County, Winter

Phase Name	Offroad Equipment Count	Worker Trip Number	Vendor Trip Number	Hauling Trip Number	Worker Trip Length	Vendor Trip Length	Hauling Trip Length	Worker Vehicle Class	Vendor Vehicle Class	Hauling Vehicle Class
Demolition	6	15.00	0.00	458.00	10.00	6.90	20.00	LD_Mix	HDT_Mix	HHDT
Site Preparation	7	18.00	0.00	0.00	10.00	6.90	20.00	LD_Mix	HDT_Mix	HHDT
Grading	8	20.00	0.00	0.00	10.00	6.90	20.00	LD_Mix	HDT_Mix	HHDT
Building Construction	9	801.00	143.00	0.00	10.00	6.90	20.00	LD_Mix	HDT_Mix	HHDT
Paving	6	15.00	0.00	0.00	10.00	6.90	20.00	LD_Mix	HDT_Mix	HHDT
Architectural Coating	1	160.00	0.00	0.00	10.00	6.90	20.00	LD_Mix	HDT_Mix	HHDT

3.1 Mitigation Measures Construction

3.2 Demolition - 2021

Unmitigated Construction On-Site

	ROG	NOx	CO	SO2	Fugitive PM10	Exhaust PM10	PM10 Total	Fugitive PM2.5	Exhaust PM2.5	PM2.5 Total	Bio- CO2	NBio- CO2	Total CO2	CH4	N2O	CO2e
Category	lb/day										lb/day					
Fugitive Dust					3.3074	0.0000	3.3074	0.5008	0.0000	0.5008			0.0000			0.0000
Off-Road	3.1651	31.4407	21.5650	0.0388		1.5513	1.5513		1.4411	1.4411		3,747.9449	3,747.9449	1.0549		3,774.3174
Total	3.1651	31.4407	21.5650	0.0388	3.3074	1.5513	4.8588	0.5008	1.4411	1.9419		3,747.9449	3,747.9449	1.0549		3,774.3174

Village South Specific Plan (Proposed) - Los Angeles-South Coast County, Winter

3.2 Demolition - 2021

Unmitigated Construction Off-Site

	ROG	NOx	CO	SO2	Fugitive PM10	Exhaust PM10	PM10 Total	Fugitive PM2.5	Exhaust PM2.5	PM2.5 Total	Bio- CO2	NBio- CO2	Total CO2	CH4	N2O	CO2e
Category	lb/day										lb/day					
Hauling	0.1304	4.1454	1.0182	0.0117	0.2669	0.0128	0.2797	0.0732	0.0122	0.0854		1,269.8555	1,269.8555	0.0908		1,272.1252
Vendor	0.0000	0.0000	0.0000	0.0000	0.0000	0.0000	0.0000	0.0000	0.0000	0.0000		0.0000	0.0000	0.0000		0.0000
Worker	0.0532	0.0346	0.3963	1.1100e-003	0.1141	9.5000e-004	0.1151	0.0303	8.8000e-004	0.0311		110.4707	110.4707	3.3300e-003		110.5539
Total	0.1835	4.1800	1.4144	0.0128	0.3810	0.0137	0.3948	0.1034	0.0131	0.1165		1,380.3262	1,380.3262	0.0941		1,382.6791

Mitigated Construction On-Site

	ROG	NOx	CO	SO2	Fugitive PM10	Exhaust PM10	PM10 Total	Fugitive PM2.5	Exhaust PM2.5	PM2.5 Total	Bio- CO2	NBio- CO2	Total CO2	CH4	N2O	CO2e
Category	lb/day										lb/day					
Fugitive Dust					3.3074	0.0000	3.3074	0.5008	0.0000	0.5008			0.0000			0.0000
Off-Road	3.1651	31.4407	21.5650	0.0388		1.5513	1.5513		1.4411	1.4411	0.0000	3,747.9449	3,747.9449	1.0549		3,774.3174
Total	3.1651	31.4407	21.5650	0.0388	3.3074	1.5513	4.8588	0.5008	1.4411	1.9419	0.0000	3,747.9449	3,747.9449	1.0549		3,774.3174

Village South Specific Plan (Proposed) - Los Angeles-South Coast County, Winter

3.2 Demolition - 2021

Mitigated Construction Off-Site

	ROG	NOx	CO	SO2	Fugitive PM10	Exhaust PM10	PM10 Total	Fugitive PM2.5	Exhaust PM2.5	PM2.5 Total	Bio- CO2	NBio- CO2	Total CO2	CH4	N2O	CO2e
Category	lb/day										lb/day					
Hauling	0.1304	4.1454	1.0182	0.0117	0.2669	0.0128	0.2797	0.0732	0.0122	0.0854		1,269.8555	1,269.8555	0.0908		1,272.1252
Vendor	0.0000	0.0000	0.0000	0.0000	0.0000	0.0000	0.0000	0.0000	0.0000	0.0000		0.0000	0.0000	0.0000		0.0000
Worker	0.0532	0.0346	0.3963	1.1100e-003	0.1141	9.5000e-004	0.1151	0.0303	8.8000e-004	0.0311		110.4707	110.4707	3.3300e-003		110.5539
Total	0.1835	4.1800	1.4144	0.0128	0.3810	0.0137	0.3948	0.1034	0.0131	0.1165		1,380.3262	1,380.3262	0.0941		1,382.6791

3.3 Site Preparation - 2021

Unmitigated Construction On-Site

	ROG	NOx	CO	SO2	Fugitive PM10	Exhaust PM10	PM10 Total	Fugitive PM2.5	Exhaust PM2.5	PM2.5 Total	Bio- CO2	NBio- CO2	Total CO2	CH4	N2O	CO2e
Category	lb/day										lb/day					
Fugitive Dust					18.0663	0.0000	18.0663	9.9307	0.0000	9.9307			0.0000			0.0000
Off-Road	3.8882	40.4971	21.1543	0.0380		2.0445	2.0445		1.8809	1.8809		3,685.6569	3,685.6569	1.1920		3,715.4573
Total	3.8882	40.4971	21.1543	0.0380	18.0663	2.0445	20.1107	9.9307	1.8809	11.8116		3,685.6569	3,685.6569	1.1920		3,715.4573

Village South Specific Plan (Proposed) - Los Angeles-South Coast County, Winter

3.3 Site Preparation - 2021

Unmitigated Construction Off-Site

	ROG	NOx	CO	SO2	Fugitive PM10	Exhaust PM10	PM10 Total	Fugitive PM2.5	Exhaust PM2.5	PM2.5 Total	Bio- CO2	NBio- CO2	Total CO2	CH4	N2O	CO2e
Category	lb/day										lb/day					
Hauling	0.0000	0.0000	0.0000	0.0000	0.0000	0.0000	0.0000	0.0000	0.0000	0.0000		0.0000	0.0000	0.0000		0.0000
Vendor	0.0000	0.0000	0.0000	0.0000	0.0000	0.0000	0.0000	0.0000	0.0000	0.0000		0.0000	0.0000	0.0000		0.0000
Worker	0.0638	0.0415	0.4755	1.3300e-003	0.1369	1.1400e-003	0.1381	0.0363	1.0500e-003	0.0374		132.5649	132.5649	3.9900e-003		132.6646
Total	0.0638	0.0415	0.4755	1.3300e-003	0.1369	1.1400e-003	0.1381	0.0363	1.0500e-003	0.0374		132.5649	132.5649	3.9900e-003		132.6646

Mitigated Construction On-Site

	ROG	NOx	CO	SO2	Fugitive PM10	Exhaust PM10	PM10 Total	Fugitive PM2.5	Exhaust PM2.5	PM2.5 Total	Bio- CO2	NBio- CO2	Total CO2	CH4	N2O	CO2e
Category	lb/day										lb/day					
Fugitive Dust					18.0663	0.0000	18.0663	9.9307	0.0000	9.9307			0.0000			0.0000
Off-Road	3.8882	40.4971	21.1543	0.0380		2.0445	2.0445		1.8809	1.8809	0.0000	3,685.6569	3,685.6569	1.1920		3,715.4573
Total	3.8882	40.4971	21.1543	0.0380	18.0663	2.0445	20.1107	9.9307	1.8809	11.8116	0.0000	3,685.6569	3,685.6569	1.1920		3,715.4573

Village South Specific Plan (Proposed) - Los Angeles-South Coast County, Winter

3.3 Site Preparation - 2021

Mitigated Construction Off-Site

	ROG	NOx	CO	SO2	Fugitive PM10	Exhaust PM10	PM10 Total	Fugitive PM2.5	Exhaust PM2.5	PM2.5 Total	Bio- CO2	NBio- CO2	Total CO2	CH4	N2O	CO2e
Category	lb/day										lb/day					
Hauling	0.0000	0.0000	0.0000	0.0000	0.0000	0.0000	0.0000	0.0000	0.0000	0.0000		0.0000	0.0000	0.0000		0.0000
Vendor	0.0000	0.0000	0.0000	0.0000	0.0000	0.0000	0.0000	0.0000	0.0000	0.0000		0.0000	0.0000	0.0000		0.0000
Worker	0.0638	0.0415	0.4755	1.3300e-003	0.1369	1.1400e-003	0.1381	0.0363	1.0500e-003	0.0374		132.5649	132.5649	3.9900e-003		132.6646
Total	0.0638	0.0415	0.4755	1.3300e-003	0.1369	1.1400e-003	0.1381	0.0363	1.0500e-003	0.0374		132.5649	132.5649	3.9900e-003		132.6646

3.4 Grading - 2021

Unmitigated Construction On-Site

	ROG	NOx	CO	SO2	Fugitive PM10	Exhaust PM10	PM10 Total	Fugitive PM2.5	Exhaust PM2.5	PM2.5 Total	Bio- CO2	NBio- CO2	Total CO2	CH4	N2O	CO2e
Category	lb/day										lb/day					
Fugitive Dust					8.6733	0.0000	8.6733	3.5965	0.0000	3.5965			0.0000			0.0000
Off-Road	4.1912	46.3998	30.8785	0.0620		1.9853	1.9853		1.8265	1.8265		6,007.0434	6,007.0434	1.9428		6,055.6134
Total	4.1912	46.3998	30.8785	0.0620	8.6733	1.9853	10.6587	3.5965	1.8265	5.4230		6,007.0434	6,007.0434	1.9428		6,055.6134

Village South Specific Plan (Proposed) - Los Angeles-South Coast County, Winter

3.4 Grading - 2021

Unmitigated Construction Off-Site

	ROG	NOx	CO	SO2	Fugitive PM10	Exhaust PM10	PM10 Total	Fugitive PM2.5	Exhaust PM2.5	PM2.5 Total	Bio- CO2	NBio- CO2	Total CO2	CH4	N2O	CO2e
Category	lb/day										lb/day					
Hauling	0.0000	0.0000	0.0000	0.0000	0.0000	0.0000	0.0000	0.0000	0.0000	0.0000		0.0000	0.0000	0.0000		0.0000
Vendor	0.0000	0.0000	0.0000	0.0000	0.0000	0.0000	0.0000	0.0000	0.0000	0.0000		0.0000	0.0000	0.0000		0.0000
Worker	0.0709	0.0462	0.5284	1.4800e-003	0.1521	1.2700e-003	0.1534	0.0404	1.1700e-003	0.0415		147.2943	147.2943	4.4300e-003		147.4051
Total	0.0709	0.0462	0.5284	1.4800e-003	0.1521	1.2700e-003	0.1534	0.0404	1.1700e-003	0.0415		147.2943	147.2943	4.4300e-003		147.4051

Mitigated Construction On-Site

	ROG	NOx	CO	SO2	Fugitive PM10	Exhaust PM10	PM10 Total	Fugitive PM2.5	Exhaust PM2.5	PM2.5 Total	Bio- CO2	NBio- CO2	Total CO2	CH4	N2O	CO2e
Category	lb/day										lb/day					
Fugitive Dust					8.6733	0.0000	8.6733	3.5965	0.0000	3.5965			0.0000			0.0000
Off-Road	4.1912	46.3998	30.8785	0.0620		1.9853	1.9853		1.8265	1.8265	0.0000	6,007.0434	6,007.0434	1.9428		6,055.6134
Total	4.1912	46.3998	30.8785	0.0620	8.6733	1.9853	10.6587	3.5965	1.8265	5.4230	0.0000	6,007.0434	6,007.0434	1.9428		6,055.6134

Village South Specific Plan (Proposed) - Los Angeles-South Coast County, Winter

3.4 Grading - 2021

Mitigated Construction Off-Site

	ROG	NOx	CO	SO2	Fugitive PM10	Exhaust PM10	PM10 Total	Fugitive PM2.5	Exhaust PM2.5	PM2.5 Total	Bio- CO2	NBio- CO2	Total CO2	CH4	N2O	CO2e
Category	lb/day										lb/day					
Hauling	0.0000	0.0000	0.0000	0.0000	0.0000	0.0000	0.0000	0.0000	0.0000	0.0000		0.0000	0.0000	0.0000		0.0000
Vendor	0.0000	0.0000	0.0000	0.0000	0.0000	0.0000	0.0000	0.0000	0.0000	0.0000		0.0000	0.0000	0.0000		0.0000
Worker	0.0709	0.0462	0.5284	1.4800e-003	0.1521	1.2700e-003	0.1534	0.0404	1.1700e-003	0.0415		147.2943	147.2943	4.4300e-003		147.4051
Total	0.0709	0.0462	0.5284	1.4800e-003	0.1521	1.2700e-003	0.1534	0.0404	1.1700e-003	0.0415		147.2943	147.2943	4.4300e-003		147.4051

3.4 Grading - 2022

Unmitigated Construction On-Site

	ROG	NOx	CO	SO2	Fugitive PM10	Exhaust PM10	PM10 Total	Fugitive PM2.5	Exhaust PM2.5	PM2.5 Total	Bio- CO2	NBio- CO2	Total CO2	CH4	N2O	CO2e
Category	lb/day										lb/day					
Fugitive Dust					8.6733	0.0000	8.6733	3.5965	0.0000	3.5965			0.0000			0.0000
Off-Road	3.6248	38.8435	29.0415	0.0621		1.6349	1.6349		1.5041	1.5041		6,011.4105	6,011.4105	1.9442		6,060.0158
Total	3.6248	38.8435	29.0415	0.0621	8.6733	1.6349	10.3082	3.5965	1.5041	5.1006		6,011.4105	6,011.4105	1.9442		6,060.0158

Village South Specific Plan (Proposed) - Los Angeles-South Coast County, Winter

3.4 Grading - 2022

Unmitigated Construction Off-Site

	ROG	NOx	CO	SO2	Fugitive PM10	Exhaust PM10	PM10 Total	Fugitive PM2.5	Exhaust PM2.5	PM2.5 Total	Bio- CO2	NBio- CO2	Total CO2	CH4	N2O	CO2e
Category	lb/day										lb/day					
Hauling	0.0000	0.0000	0.0000	0.0000	0.0000	0.0000	0.0000	0.0000	0.0000	0.0000		0.0000	0.0000	0.0000		0.0000
Vendor	0.0000	0.0000	0.0000	0.0000	0.0000	0.0000	0.0000	0.0000	0.0000	0.0000		0.0000	0.0000	0.0000		0.0000
Worker	0.0665	0.0416	0.4861	1.4300e-003	0.1521	1.2300e-003	0.1534	0.0404	1.1300e-003	0.0415		142.1207	142.1207	4.0000e-003		142.2207
Total	0.0665	0.0416	0.4861	1.4300e-003	0.1521	1.2300e-003	0.1534	0.0404	1.1300e-003	0.0415		142.1207	142.1207	4.0000e-003		142.2207

Mitigated Construction On-Site

	ROG	NOx	CO	SO2	Fugitive PM10	Exhaust PM10	PM10 Total	Fugitive PM2.5	Exhaust PM2.5	PM2.5 Total	Bio- CO2	NBio- CO2	Total CO2	CH4	N2O	CO2e
Category	lb/day										lb/day					
Fugitive Dust					8.6733	0.0000	8.6733	3.5965	0.0000	3.5965			0.0000			0.0000
Off-Road	3.6248	38.8435	29.0415	0.0621		1.6349	1.6349		1.5041	1.5041	0.0000	6,011.4105	6,011.4105	1.9442		6,060.0158
Total	3.6248	38.8435	29.0415	0.0621	8.6733	1.6349	10.3082	3.5965	1.5041	5.1006	0.0000	6,011.4105	6,011.4105	1.9442		6,060.0158

Village South Specific Plan (Proposed) - Los Angeles-South Coast County, Winter

3.4 Grading - 2022

Mitigated Construction Off-Site

	ROG	NOx	CO	SO2	Fugitive PM10	Exhaust PM10	PM10 Total	Fugitive PM2.5	Exhaust PM2.5	PM2.5 Total	Bio- CO2	NBio- CO2	Total CO2	CH4	N2O	CO2e
Category	lb/day										lb/day					
Hauling	0.0000	0.0000	0.0000	0.0000	0.0000	0.0000	0.0000	0.0000	0.0000	0.0000		0.0000	0.0000	0.0000		0.0000
Vendor	0.0000	0.0000	0.0000	0.0000	0.0000	0.0000	0.0000	0.0000	0.0000	0.0000		0.0000	0.0000	0.0000		0.0000
Worker	0.0665	0.0416	0.4861	1.4300e-003	0.1521	1.2300e-003	0.1534	0.0404	1.1300e-003	0.0415		142.1207	142.1207	4.0000e-003		142.2207
Total	0.0665	0.0416	0.4861	1.4300e-003	0.1521	1.2300e-003	0.1534	0.0404	1.1300e-003	0.0415		142.1207	142.1207	4.0000e-003		142.2207

3.5 Building Construction - 2022

Unmitigated Construction On-Site

	ROG	NOx	CO	SO2	Fugitive PM10	Exhaust PM10	PM10 Total	Fugitive PM2.5	Exhaust PM2.5	PM2.5 Total	Bio- CO2	NBio- CO2	Total CO2	CH4	N2O	CO2e
Category	lb/day										lb/day					
Off-Road	1.7062	15.6156	16.3634	0.0269		0.8090	0.8090		0.7612	0.7612		2,554.3336	2,554.3336	0.6120		2,569.6322
Total	1.7062	15.6156	16.3634	0.0269		0.8090	0.8090		0.7612	0.7612		2,554.3336	2,554.3336	0.6120		2,569.6322

Village South Specific Plan (Proposed) - Los Angeles-South Coast County, Winter

3.5 Building Construction - 2022

Unmitigated Construction Off-Site

	ROG	NOx	CO	SO2	Fugitive PM10	Exhaust PM10	PM10 Total	Fugitive PM2.5	Exhaust PM2.5	PM2.5 Total	Bio- CO2	NBio- CO2	Total CO2	CH4	N2O	CO2e
Category	lb/day										lb/day					
Hauling	0.0000	0.0000	0.0000	0.0000	0.0000	0.0000	0.0000	0.0000	0.0000	0.0000		0.0000	0.0000	0.0000		0.0000
Vendor	0.4284	13.1673	3.8005	0.0354	0.9155	0.0256	0.9412	0.2636	0.0245	0.2881		3,789.0750	3,789.0750	0.2381		3,795.0283
Worker	2.6620	1.6677	19.4699	0.0571	6.0932	0.0493	6.1425	1.6163	0.0454	1.6617		5,691.9354	5,691.9354	0.1602		5,695.9408
Total	3.0904	14.8350	23.2704	0.0926	7.0087	0.0749	7.0836	1.8799	0.0699	1.9498		9,481.0104	9,481.0104	0.3984		9,490.9691

Mitigated Construction On-Site

	ROG	NOx	CO	SO2	Fugitive PM10	Exhaust PM10	PM10 Total	Fugitive PM2.5	Exhaust PM2.5	PM2.5 Total	Bio- CO2	NBio- CO2	Total CO2	CH4	N2O	CO2e
Category	lb/day										lb/day					
Off-Road	1.7062	15.6156	16.3634	0.0269		0.8090	0.8090		0.7612	0.7612	0.0000	2,554.3336	2,554.3336	0.6120		2,569.6322
Total	1.7062	15.6156	16.3634	0.0269		0.8090	0.8090		0.7612	0.7612	0.0000	2,554.3336	2,554.3336	0.6120		2,569.6322

Village South Specific Plan (Proposed) - Los Angeles-South Coast County, Winter

3.5 Building Construction - 2022

Mitigated Construction Off-Site

	ROG	NOx	CO	SO2	Fugitive PM10	Exhaust PM10	PM10 Total	Fugitive PM2.5	Exhaust PM2.5	PM2.5 Total	Bio- CO2	NBio- CO2	Total CO2	CH4	N2O	CO2e
Category	lb/day										lb/day					
Hauling	0.0000	0.0000	0.0000	0.0000	0.0000	0.0000	0.0000	0.0000	0.0000	0.0000		0.0000	0.0000	0.0000		0.0000
Vendor	0.4284	13.1673	3.8005	0.0354	0.9155	0.0256	0.9412	0.2636	0.0245	0.2881		3,789.0750	3,789.0750	0.2381		3,795.0283
Worker	2.6620	1.6677	19.4699	0.0571	6.0932	0.0493	6.1425	1.6163	0.0454	1.6617		5,691.9354	5,691.9354	0.1602		5,695.9408
Total	3.0904	14.8350	23.2704	0.0926	7.0087	0.0749	7.0836	1.8799	0.0699	1.9498		9,481.0104	9,481.0104	0.3984		9,490.9691

3.5 Building Construction - 2023

Unmitigated Construction On-Site

	ROG	NOx	CO	SO2	Fugitive PM10	Exhaust PM10	PM10 Total	Fugitive PM2.5	Exhaust PM2.5	PM2.5 Total	Bio- CO2	NBio- CO2	Total CO2	CH4	N2O	CO2e
Category	lb/day										lb/day					
Off-Road	1.5728	14.3849	16.2440	0.0269		0.6997	0.6997		0.6584	0.6584		2,555.2099	2,555.2099	0.6079		2,570.4061
Total	1.5728	14.3849	16.2440	0.0269		0.6997	0.6997		0.6584	0.6584		2,555.2099	2,555.2099	0.6079		2,570.4061

Village South Specific Plan (Proposed) - Los Angeles-South Coast County, Winter

3.5 Building Construction - 2023

Unmitigated Construction Off-Site

	ROG	NOx	CO	SO2	Fugitive PM10	Exhaust PM10	PM10 Total	Fugitive PM2.5	Exhaust PM2.5	PM2.5 Total	Bio- CO2	NBio- CO2	Total CO2	CH4	N2O	CO2e
Category	lb/day										lb/day					
Hauling	0.0000	0.0000	0.0000	0.0000	0.0000	0.0000	0.0000	0.0000	0.0000	0.0000		0.0000	0.0000	0.0000		0.0000
Vendor	0.3183	9.9726	3.3771	0.0343	0.9156	0.0122	0.9277	0.2636	0.0116	0.2752		3,671.4007	3,671.4007	0.2096		3,676.6417
Worker	2.5029	1.5073	17.8820	0.0550	6.0932	0.0479	6.1411	1.6163	0.0441	1.6604		5,483.7974	5,483.7974	0.1442		5,487.4020
Total	2.8211	11.4799	21.2591	0.0893	7.0088	0.0601	7.0688	1.8799	0.0557	1.9356		9,155.1981	9,155.1981	0.3538		9,164.0437

Mitigated Construction On-Site

	ROG	NOx	CO	SO2	Fugitive PM10	Exhaust PM10	PM10 Total	Fugitive PM2.5	Exhaust PM2.5	PM2.5 Total	Bio- CO2	NBio- CO2	Total CO2	CH4	N2O	CO2e
Category	lb/day										lb/day					
Off-Road	1.5728	14.3849	16.2440	0.0269		0.6997	0.6997		0.6584	0.6584	0.0000	2,555.2099	2,555.2099	0.6079		2,570.4061
Total	1.5728	14.3849	16.2440	0.0269		0.6997	0.6997		0.6584	0.6584	0.0000	2,555.2099	2,555.2099	0.6079		2,570.4061

Village South Specific Plan (Proposed) - Los Angeles-South Coast County, Winter

3.5 Building Construction - 2023

Mitigated Construction Off-Site

	ROG	NOx	CO	SO2	Fugitive PM10	Exhaust PM10	PM10 Total	Fugitive PM2.5	Exhaust PM2.5	PM2.5 Total	Bio- CO2	NBio- CO2	Total CO2	CH4	N2O	CO2e
Category	lb/day										lb/day					
Hauling	0.0000	0.0000	0.0000	0.0000	0.0000	0.0000	0.0000	0.0000	0.0000	0.0000		0.0000	0.0000	0.0000		0.0000
Vendor	0.3183	9.9726	3.3771	0.0343	0.9156	0.0122	0.9277	0.2636	0.0116	0.2752		3,671.4007	3,671.4007	0.2096		3,676.6417
Worker	2.5029	1.5073	17.8820	0.0550	6.0932	0.0479	6.1411	1.6163	0.0441	1.6604		5,483.7974	5,483.7974	0.1442		5,487.4020
Total	2.8211	11.4799	21.2591	0.0893	7.0088	0.0601	7.0688	1.8799	0.0557	1.9356		9,155.1981	9,155.1981	0.3538		9,164.0437

3.6 Paving - 2023

Unmitigated Construction On-Site

	ROG	NOx	CO	SO2	Fugitive PM10	Exhaust PM10	PM10 Total	Fugitive PM2.5	Exhaust PM2.5	PM2.5 Total	Bio- CO2	NBio- CO2	Total CO2	CH4	N2O	CO2e
Category	lb/day										lb/day					
Off-Road	1.0327	10.1917	14.5842	0.0228		0.5102	0.5102		0.4694	0.4694		2,207.5841	2,207.5841	0.7140		2,225.4336
Paving	0.0000					0.0000	0.0000		0.0000	0.0000			0.0000			0.0000
Total	1.0327	10.1917	14.5842	0.0228		0.5102	0.5102		0.4694	0.4694		2,207.5841	2,207.5841	0.7140		2,225.4336

Village South Specific Plan (Proposed) - Los Angeles-South Coast County, Winter

3.6 Paving - 2023

Unmitigated Construction Off-Site

	ROG	NOx	CO	SO2	Fugitive PM10	Exhaust PM10	PM10 Total	Fugitive PM2.5	Exhaust PM2.5	PM2.5 Total	Bio- CO2	NBio- CO2	Total CO2	CH4	N2O	CO2e
Category	lb/day										lb/day					
Hauling	0.0000	0.0000	0.0000	0.0000	0.0000	0.0000	0.0000	0.0000	0.0000	0.0000		0.0000	0.0000	0.0000		0.0000
Vendor	0.0000	0.0000	0.0000	0.0000	0.0000	0.0000	0.0000	0.0000	0.0000	0.0000		0.0000	0.0000	0.0000		0.0000
Worker	0.0469	0.0282	0.3349	1.0300e-003	0.1141	9.0000e-004	0.1150	0.0303	8.3000e-004	0.0311		102.6928	102.6928	2.7000e-003		102.7603
Total	0.0469	0.0282	0.3349	1.0300e-003	0.1141	9.0000e-004	0.1150	0.0303	8.3000e-004	0.0311		102.6928	102.6928	2.7000e-003		102.7603

Mitigated Construction On-Site

	ROG	NOx	CO	SO2	Fugitive PM10	Exhaust PM10	PM10 Total	Fugitive PM2.5	Exhaust PM2.5	PM2.5 Total	Bio- CO2	NBio- CO2	Total CO2	CH4	N2O	CO2e
Category	lb/day										lb/day					
Off-Road	1.0327	10.1917	14.5842	0.0228		0.5102	0.5102		0.4694	0.4694	0.0000	2,207.5841	2,207.5841	0.7140		2,225.4336
Paving	0.0000					0.0000	0.0000		0.0000	0.0000			0.0000			0.0000
Total	1.0327	10.1917	14.5842	0.0228		0.5102	0.5102		0.4694	0.4694	0.0000	2,207.5841	2,207.5841	0.7140		2,225.4336

Village South Specific Plan (Proposed) - Los Angeles-South Coast County, Winter

3.6 Paving - 2023

Mitigated Construction Off-Site

	ROG	NOx	CO	SO2	Fugitive PM10	Exhaust PM10	PM10 Total	Fugitive PM2.5	Exhaust PM2.5	PM2.5 Total	Bio- CO2	NBio- CO2	Total CO2	CH4	N2O	CO2e
Category	lb/day										lb/day					
Hauling	0.0000	0.0000	0.0000	0.0000	0.0000	0.0000	0.0000	0.0000	0.0000	0.0000		0.0000	0.0000	0.0000		0.0000
Vendor	0.0000	0.0000	0.0000	0.0000	0.0000	0.0000	0.0000	0.0000	0.0000	0.0000		0.0000	0.0000	0.0000		0.0000
Worker	0.0469	0.0282	0.3349	1.0300e-003	0.1141	9.0000e-004	0.1150	0.0303	8.3000e-004	0.0311		102.6928	102.6928	2.7000e-003		102.7603
Total	0.0469	0.0282	0.3349	1.0300e-003	0.1141	9.0000e-004	0.1150	0.0303	8.3000e-004	0.0311		102.6928	102.6928	2.7000e-003		102.7603

3.6 Paving - 2024

Unmitigated Construction On-Site

	ROG	NOx	CO	SO2	Fugitive PM10	Exhaust PM10	PM10 Total	Fugitive PM2.5	Exhaust PM2.5	PM2.5 Total	Bio- CO2	NBio- CO2	Total CO2	CH4	N2O	CO2e
Category	lb/day										lb/day					
Off-Road	0.9882	9.5246	14.6258	0.0228		0.4685	0.4685		0.4310	0.4310		2,207.5472	2,207.5472	0.7140		2,225.3963
Paving	0.0000					0.0000	0.0000		0.0000	0.0000			0.0000			0.0000
Total	0.9882	9.5246	14.6258	0.0228		0.4685	0.4685		0.4310	0.4310		2,207.5472	2,207.5472	0.7140		2,225.3963

Village South Specific Plan (Proposed) - Los Angeles-South Coast County, Winter

3.6 Paving - 2024

Unmitigated Construction Off-Site

	ROG	NOx	CO	SO2	Fugitive PM10	Exhaust PM10	PM10 Total	Fugitive PM2.5	Exhaust PM2.5	PM2.5 Total	Bio- CO2	NBio- CO2	Total CO2	CH4	N2O	CO2e
Category	lb/day										lb/day					
Hauling	0.0000	0.0000	0.0000	0.0000	0.0000	0.0000	0.0000	0.0000	0.0000	0.0000		0.0000	0.0000	0.0000		0.0000
Vendor	0.0000	0.0000	0.0000	0.0000	0.0000	0.0000	0.0000	0.0000	0.0000	0.0000		0.0000	0.0000	0.0000		0.0000
Worker	0.0444	0.0257	0.3114	1.0000e-003	0.1141	8.8000e-004	0.1150	0.0303	8.1000e-004	0.0311		99.5045	99.5045	2.4700e-003		99.5663
Total	0.0444	0.0257	0.3114	1.0000e-003	0.1141	8.8000e-004	0.1150	0.0303	8.1000e-004	0.0311		99.5045	99.5045	2.4700e-003		99.5663

Mitigated Construction On-Site

	ROG	NOx	CO	SO2	Fugitive PM10	Exhaust PM10	PM10 Total	Fugitive PM2.5	Exhaust PM2.5	PM2.5 Total	Bio- CO2	NBio- CO2	Total CO2	CH4	N2O	CO2e
Category	lb/day										lb/day					
Off-Road	0.9882	9.5246	14.6258	0.0228		0.4685	0.4685		0.4310	0.4310	0.0000	2,207.5472	2,207.5472	0.7140		2,225.3963
Paving	0.0000					0.0000	0.0000		0.0000	0.0000			0.0000			0.0000
Total	0.9882	9.5246	14.6258	0.0228		0.4685	0.4685		0.4310	0.4310	0.0000	2,207.5472	2,207.5472	0.7140		2,225.3963

Village South Specific Plan (Proposed) - Los Angeles-South Coast County, Winter

3.6 Paving - 2024

Mitigated Construction Off-Site

	ROG	NOx	CO	SO2	Fugitive PM10	Exhaust PM10	PM10 Total	Fugitive PM2.5	Exhaust PM2.5	PM2.5 Total	Bio- CO2	NBio- CO2	Total CO2	CH4	N2O	CO2e
Category	lb/day										lb/day					
Hauling	0.0000	0.0000	0.0000	0.0000	0.0000	0.0000	0.0000	0.0000	0.0000	0.0000		0.0000	0.0000	0.0000		0.0000
Vendor	0.0000	0.0000	0.0000	0.0000	0.0000	0.0000	0.0000	0.0000	0.0000	0.0000		0.0000	0.0000	0.0000		0.0000
Worker	0.0444	0.0257	0.3114	1.0000e-003	0.1141	8.8000e-004	0.1150	0.0303	8.1000e-004	0.0311		99.5045	99.5045	2.4700e-003		99.5663
Total	0.0444	0.0257	0.3114	1.0000e-003	0.1141	8.8000e-004	0.1150	0.0303	8.1000e-004	0.0311		99.5045	99.5045	2.4700e-003		99.5663

3.7 Architectural Coating - 2024

Unmitigated Construction On-Site

	ROG	NOx	CO	SO2	Fugitive PM10	Exhaust PM10	PM10 Total	Fugitive PM2.5	Exhaust PM2.5	PM2.5 Total	Bio- CO2	NBio- CO2	Total CO2	CH4	N2O	CO2e
Category	lb/day										lb/day					
Archit. Coating	236.4115					0.0000	0.0000		0.0000	0.0000			0.0000			0.0000
Off-Road	0.1808	1.2188	1.8101	2.9700e-003		0.0609	0.0609		0.0609	0.0609		281.4481	281.4481	0.0159		281.8443
Total	236.5923	1.2188	1.8101	2.9700e-003		0.0609	0.0609		0.0609	0.0609		281.4481	281.4481	0.0159		281.8443

Village South Specific Plan (Proposed) - Los Angeles-South Coast County, Winter

3.7 Architectural Coating - 2024

Unmitigated Construction Off-Site

	ROG	NOx	CO	SO2	Fugitive PM10	Exhaust PM10	PM10 Total	Fugitive PM2.5	Exhaust PM2.5	PM2.5 Total	Bio- CO2	NBio- CO2	Total CO2	CH4	N2O	CO2e
Category	lb/day										lb/day					
Hauling	0.0000	0.0000	0.0000	0.0000	0.0000	0.0000	0.0000	0.0000	0.0000	0.0000		0.0000	0.0000	0.0000		0.0000
Vendor	0.0000	0.0000	0.0000	0.0000	0.0000	0.0000	0.0000	0.0000	0.0000	0.0000		0.0000	0.0000	0.0000		0.0000
Worker	0.4734	0.2743	3.3220	0.0107	1.2171	9.4300e-003	1.2266	0.3229	8.6800e-003	0.3315		1,061.3818	1,061.3818	0.0264		1,062.0410
Total	0.4734	0.2743	3.3220	0.0107	1.2171	9.4300e-003	1.2266	0.3229	8.6800e-003	0.3315		1,061.3818	1,061.3818	0.0264		1,062.0410

Mitigated Construction On-Site

	ROG	NOx	CO	SO2	Fugitive PM10	Exhaust PM10	PM10 Total	Fugitive PM2.5	Exhaust PM2.5	PM2.5 Total	Bio- CO2	NBio- CO2	Total CO2	CH4	N2O	CO2e
Category	lb/day										lb/day					
Archit. Coating	236.4115					0.0000	0.0000		0.0000	0.0000			0.0000			0.0000
Off-Road	0.1808	1.2188	1.8101	2.9700e-003		0.0609	0.0609		0.0609	0.0609	0.0000	281.4481	281.4481	0.0159		281.8443
Total	236.5923	1.2188	1.8101	2.9700e-003		0.0609	0.0609		0.0609	0.0609	0.0000	281.4481	281.4481	0.0159		281.8443

Village South Specific Plan (Proposed) - Los Angeles-South Coast County, Winter

3.7 Architectural Coating - 2024

Mitigated Construction Off-Site

	ROG	NOx	CO	SO2	Fugitive PM10	Exhaust PM10	PM10 Total	Fugitive PM2.5	Exhaust PM2.5	PM2.5 Total	Bio- CO2	NBio- CO2	Total CO2	CH4	N2O	CO2e
Category	lb/day										lb/day					
Hauling	0.0000	0.0000	0.0000	0.0000	0.0000	0.0000	0.0000	0.0000	0.0000	0.0000		0.0000	0.0000	0.0000		0.0000
Vendor	0.0000	0.0000	0.0000	0.0000	0.0000	0.0000	0.0000	0.0000	0.0000	0.0000		0.0000	0.0000	0.0000		0.0000
Worker	0.4734	0.2743	3.3220	0.0107	1.2171	9.4300e-003	1.2266	0.3229	8.6800e-003	0.3315		1,061.3818	1,061.3818	0.0264		1,062.0410
Total	0.4734	0.2743	3.3220	0.0107	1.2171	9.4300e-003	1.2266	0.3229	8.6800e-003	0.3315		1,061.3818	1,061.3818	0.0264		1,062.0410

4.0 Operational Detail - Mobile

4.1 Mitigation Measures Mobile

Village South Specific Plan (Proposed) - Los Angeles-South Coast County, Winter

	ROG	NOx	CO	SO2	Fugitive PM10	Exhaust PM10	PM10 Total	Fugitive PM2.5	Exhaust PM2.5	PM2.5 Total	Bio- CO2	NBio- CO2	Total CO2	CH4	N2O	CO2e
Category	lb/day										lb/day					
Mitigated	9.5233	45.9914	110.0422	0.4681	45.9592	0.3373	46.2965	12.2950	0.3132	12.6083		47,917.8005	47,917.8005	2.1953		47,972.6839
Unmitigated	9.5233	45.9914	110.0422	0.4681	45.9592	0.3373	46.2965	12.2950	0.3132	12.6083		47,917.8005	47,917.8005	2.1953		47,972.6839

4.2 Trip Summary Information

Land Use	Average Daily Trip Rate			Unmitigated	Mitigated
	Weekday	Saturday	Sunday	Annual VMT	Annual VMT
Apartments Low Rise	145.75	154.25	154.00	506,227	506,227
Apartments Mid Rise	4,026.75	3,773.25	4075.50	13,660,065	13,660,065
General Office Building	288.45	62.55	31.05	706,812	706,812
High Turnover (Sit Down Restaurant)	2,368.80	2,873.52	2817.72	3,413,937	3,413,937
Hotel	192.00	187.50	160.00	445,703	445,703
Quality Restaurant	501.12	511.92	461.20	707,488	707,488
Regional Shopping Center	528.08	601.44	357.84	1,112,221	1,112,221
Total	8,050.95	8,164.43	8,057.31	20,552,452	20,552,452

4.3 Trip Type Information

Village South Specific Plan (Proposed) - Los Angeles-South Coast County, Winter

Land Use	Miles			Trip %			Trip Purpose %		
	H-W or C-W	H-S or C-C	H-O or C-NW	H-W or C-W	H-S or C-C	H-O or C-NW	Primary	Diverted	Pass-by
Apartments Low Rise	14.70	5.90	8.70	40.20	19.20	40.60	86	11	3
Apartments Mid Rise	14.70	5.90	8.70	40.20	19.20	40.60	86	11	3
General Office Building	16.60	8.40	6.90	33.00	48.00	19.00	77	19	4
High Turnover (Sit Down Restaurant)	16.60	8.40	6.90	8.50	72.50	19.00	37	20	43
Hotel	16.60	8.40	6.90	19.40	61.60	19.00	58	38	4
Quality Restaurant	16.60	8.40	6.90	12.00	69.00	19.00	38	18	44
Regional Shopping Center	16.60	8.40	6.90	16.30	64.70	19.00	54	35	11

4.4 Fleet Mix

Land Use	LDA	LDT1	LDT2	MDV	LHD1	LHD2	MHD	HHD	OBUS	UBUS	MCY	SBUS	MH
Apartments Low Rise	0.543088	0.044216	0.209971	0.116369	0.014033	0.006332	0.021166	0.033577	0.002613	0.001817	0.005285	0.000712	0.000821
Apartments Mid Rise	0.543088	0.044216	0.209971	0.116369	0.014033	0.006332	0.021166	0.033577	0.002613	0.001817	0.005285	0.000712	0.000821
General Office Building	0.543088	0.044216	0.209971	0.116369	0.014033	0.006332	0.021166	0.033577	0.002613	0.001817	0.005285	0.000712	0.000821
High Turnover (Sit Down Restaurant)	0.543088	0.044216	0.209971	0.116369	0.014033	0.006332	0.021166	0.033577	0.002613	0.001817	0.005285	0.000712	0.000821
Hotel	0.543088	0.044216	0.209971	0.116369	0.014033	0.006332	0.021166	0.033577	0.002613	0.001817	0.005285	0.000712	0.000821
Quality Restaurant	0.543088	0.044216	0.209971	0.116369	0.014033	0.006332	0.021166	0.033577	0.002613	0.001817	0.005285	0.000712	0.000821
Regional Shopping Center	0.543088	0.044216	0.209971	0.116369	0.014033	0.006332	0.021166	0.033577	0.002613	0.001817	0.005285	0.000712	0.000821

5.0 Energy Detail

Historical Energy Use: N

5.1 Mitigation Measures Energy

Village South Specific Plan (Proposed) - Los Angeles-South Coast County, Winter

	ROG	NOx	CO	SO2	Fugitive PM10	Exhaust PM10	PM10 Total	Fugitive PM2.5	Exhaust PM2.5	PM2.5 Total	Bio- CO2	NBio- CO2	Total CO2	CH4	N2O	CO2e
Category	lb/day										lb/day					
NaturalGas Mitigated	0.7660	6.7462	4.2573	0.0418		0.5292	0.5292		0.5292	0.5292		8,355.983 2	8,355.983 2	0.1602	0.1532	8,405.638 7
NaturalGas Unmitigated	0.7660	6.7462	4.2573	0.0418		0.5292	0.5292		0.5292	0.5292		8,355.983 2	8,355.983 2	0.1602	0.1532	8,405.638 7

Village South Specific Plan (Proposed) - Los Angeles-South Coast County, Winter

5.2 Energy by Land Use - NaturalGas

Unmitigated

	NaturalGas Use	ROG	NOx	CO	SO2	Fugitive PM10	Exhaust PM10	PM10 Total	Fugitive PM2.5	Exhaust PM2.5	PM2.5 Total	Bio- CO2	NBio- CO2	Total CO2	CH4	N2O	CO2e
Land Use	kBTU/yr	lb/day										lb/day					
Apartments Low Rise	1119.16	0.0121	0.1031	0.0439	6.6000e-004		8.3400e-003	8.3400e-003		8.3400e-003	8.3400e-003		131.6662	131.6662	2.5200e-003	2.4100e-003	132.4486
Apartments Mid Rise	35784.3	0.3859	3.2978	1.4033	0.0211		0.2666	0.2666		0.2666	0.2666		4,209.9164	4,209.9164	0.0807	0.0772	4,234.9339
General Office Building	1283.42	0.0138	0.1258	0.1057	7.5000e-004		9.5600e-003	9.5600e-003		9.5600e-003	9.5600e-003		150.9911	150.9911	2.8900e-003	2.7700e-003	151.8884
High Turnover (Sit Down Restaurant)	22759.9	0.2455	2.2314	1.8743	0.0134		0.1696	0.1696		0.1696	0.1696		2,677.6342	2,677.6342	0.0513	0.0491	2,693.5460
Hotel	4769.72	0.0514	0.4676	0.3928	2.8100e-003		0.0355	0.0355		0.0355	0.0355		561.1436	561.1436	0.0108	0.0103	564.4782
Quality Restaurant	5057.75	0.0545	0.4959	0.4165	2.9800e-003		0.0377	0.0377		0.0377	0.0377		595.0298	595.0298	0.0114	0.0109	598.5658
Regional Shopping Center	251.616	2.7100e-003	0.0247	0.0207	1.5000e-004		1.8700e-003	1.8700e-003		1.8700e-003	1.8700e-003		29.6019	29.6019	5.7000e-004	5.4000e-004	29.7778
Total		0.7660	6.7463	4.2573	0.0418		0.5292	0.5292		0.5292	0.5292		8,355.9832	8,355.9832	0.1602	0.1532	8,405.6387

Village South Specific Plan (Proposed) - Los Angeles-South Coast County, Winter

5.2 Energy by Land Use - NaturalGas

Mitigated

	NaturalGas Use	ROG	NOx	CO	SO2	Fugitive PM10	Exhaust PM10	PM10 Total	Fugitive PM2.5	Exhaust PM2.5	PM2.5 Total	Bio- CO2	NBio- CO2	Total CO2	CH4	N2O	CO2e
Land Use	kBTU/yr	lb/day										lb/day					
Apartments Low Rise	1.11916	0.0121	0.1031	0.0439	6.6000e-004		8.3400e-003	8.3400e-003		8.3400e-003	8.3400e-003		131.6662	131.6662	2.5200e-003	2.4100e-003	132.4486
Apartments Mid Rise	35.7843	0.3859	3.2978	1.4033	0.0211		0.2666	0.2666		0.2666	0.2666		4,209.9164	4,209.9164	0.0807	0.0772	4,234.9339
General Office Building	1.28342	0.0138	0.1258	0.1057	7.5000e-004		9.5600e-003	9.5600e-003		9.5600e-003	9.5600e-003		150.9911	150.9911	2.8900e-003	2.7700e-003	151.8884
High Turnover (Sit Down Restaurant)	22.7599	0.2455	2.2314	1.8743	0.0134		0.1696	0.1696		0.1696	0.1696		2,677.6342	2,677.6342	0.0513	0.0491	2,693.5460
Hotel	4.76972	0.0514	0.4676	0.3928	2.8100e-003		0.0355	0.0355		0.0355	0.0355		561.1436	561.1436	0.0108	0.0103	564.4782
Quality Restaurant	5.05775	0.0545	0.4959	0.4165	2.9800e-003		0.0377	0.0377		0.0377	0.0377		595.0298	595.0298	0.0114	0.0109	598.5658
Regional Shopping Center	0.251616	2.7100e-003	0.0247	0.0207	1.5000e-004		1.8700e-003	1.8700e-003		1.8700e-003	1.8700e-003		29.6019	29.6019	5.7000e-004	5.4000e-004	29.7778
Total		0.7660	6.7463	4.2573	0.0418		0.5292	0.5292		0.5292	0.5292		8,355.9832	8,355.9832	0.1602	0.1532	8,405.6387

6.0 Area Detail

6.1 Mitigation Measures Area

Village South Specific Plan (Proposed) - Los Angeles-South Coast County, Winter

	ROG	NOx	CO	SO2	Fugitive PM10	Exhaust PM10	PM10 Total	Fugitive PM2.5	Exhaust PM2.5	PM2.5 Total	Bio- CO2	NBio- CO2	Total CO2	CH4	N2O	CO2e
Category	lb/day										lb/day					
Mitigated	30.5020	15.0496	88.4430	0.0944		1.5974	1.5974		1.5974	1.5974	0.0000	18,148.5950	18,148.5950	0.4874	0.3300	18,259.1192
Unmitigated	30.5020	15.0496	88.4430	0.0944		1.5974	1.5974		1.5974	1.5974	0.0000	18,148.5950	18,148.5950	0.4874	0.3300	18,259.1192

6.2 Area by SubCategory

Unmitigated

	ROG	NOx	CO	SO2	Fugitive PM10	Exhaust PM10	PM10 Total	Fugitive PM2.5	Exhaust PM2.5	PM2.5 Total	Bio- CO2	NBio- CO2	Total CO2	CH4	N2O	CO2e
SubCategory	lb/day										lb/day					
Architectural Coating	2.2670					0.0000	0.0000		0.0000	0.0000			0.0000			0.0000
Consumer Products	24.1085					0.0000	0.0000		0.0000	0.0000			0.0000			0.0000
Hearth	1.6500	14.1000	6.0000	0.0900		1.1400	1.1400		1.1400	1.1400	0.0000	18,000.0000	18,000.0000	0.3450	0.3300	18,106.9650
Landscaping	2.4766	0.9496	82.4430	4.3600e-003		0.4574	0.4574		0.4574	0.4574		148.5950	148.5950	0.1424		152.1542
Total	30.5020	15.0496	88.4430	0.0944		1.5974	1.5974		1.5974	1.5974	0.0000	18,148.5950	18,148.5950	0.4874	0.3300	18,259.1192

Village South Specific Plan (Proposed) - Los Angeles-South Coast County, Winter

6.2 Area by SubCategory

Mitigated

	ROG	NOx	CO	SO2	Fugitive PM10	Exhaust PM10	PM10 Total	Fugitive PM2.5	Exhaust PM2.5	PM2.5 Total	Bio- CO2	NBio- CO2	Total CO2	CH4	N2O	CO2e
SubCategory	lb/day										lb/day					
Architectural Coating	2.2670					0.0000	0.0000		0.0000	0.0000			0.0000			0.0000
Consumer Products	24.1085					0.0000	0.0000		0.0000	0.0000			0.0000			0.0000
Hearth	1.6500	14.1000	6.0000	0.0900		1.1400	1.1400		1.1400	1.1400	0.0000	18,000.0000	18,000.0000	0.3450	0.3300	18,106.9650
Landscaping	2.4766	0.9496	82.4430	4.3600e-003		0.4574	0.4574		0.4574	0.4574		148.5950	148.5950	0.1424		152.1542
Total	30.5020	15.0496	88.4430	0.0944		1.5974	1.5974		1.5974	1.5974	0.0000	18,148.5950	18,148.5950	0.4874	0.3300	18,259.1192

7.0 Water Detail

7.1 Mitigation Measures Water

8.0 Waste Detail

8.1 Mitigation Measures Waste

9.0 Operational Offroad

Equipment Type	Number	Hours/Day	Days/Year	Horse Power	Load Factor	Fuel Type
----------------	--------	-----------	-----------	-------------	-------------	-----------

10.0 Stationary Equipment

Village South Specific Plan (Proposed) - Los Angeles-South Coast County, Winter

Fire Pumps and Emergency Generators

Equipment Type	Number	Hours/Day	Hours/Year	Horse Power	Load Factor	Fuel Type
----------------	--------	-----------	------------	-------------	-------------	-----------

Boilers

Equipment Type	Number	Heat Input/Day	Heat Input/Year	Boiler Rating	Fuel Type
----------------	--------	----------------	-----------------	---------------	-----------

User Defined Equipment

Equipment Type	Number
----------------	--------

11.0 Vegetation

Attachment C

Local Hire Provision Net Change	
Without Local Hire Provision	
Total Construction GHG Emissions (MT CO2e)	3,623
Amortized (MT CO2e/year)	120.77
With Local Hire Provision	
Total Construction GHG Emissions (MT CO2e)	3,024
Amortized (MT CO2e/year)	100.80
<i>% Decrease in Construction-related GHG Emissions</i>	17%

EXHIBIT B



Paul Rosenfeld, Ph.D.

Principal Environmental Chemist

Chemical Fate and Transport & Air Dispersion Modeling

Risk Assessment & Remediation Specialist

Education

Ph.D. Soil Chemistry, University of Washington, 1999. Dissertation on volatile organic compound filtration.

M.S. Environmental Science, U.C. Berkeley, 1995. Thesis on organic waste economics.

B.A. Environmental Studies, U.C. Santa Barbara, 1991. Thesis on wastewater treatment.

Professional Experience

Dr. Rosenfeld has over 25 years' experience conducting environmental investigations and risk assessments for evaluating impacts to human health, property, and ecological receptors. His expertise focuses on the fate and transport of environmental contaminants, human health risk, exposure assessment, and ecological restoration. Dr. Rosenfeld has evaluated and modeled emissions from unconventional oil drilling operations, oil spills, landfills, boilers and incinerators, process stacks, storage tanks, confined animal feeding operations, and many other industrial and agricultural sources. His project experience ranges from monitoring and modeling of pollution sources to evaluating impacts of pollution on workers at industrial facilities and residents in surrounding communities.

Dr. Rosenfeld has investigated and designed remediation programs and risk assessments for contaminated sites containing lead, heavy metals, mold, bacteria, particulate matter, petroleum hydrocarbons, chlorinated solvents, pesticides, radioactive waste, dioxins and furans, semi- and volatile organic compounds, PCBs, PAHs, perchlorate, asbestos, per- and poly-fluoroalkyl substances (PFOA/PFOS), unusual polymers, fuel oxygenates (MTBE), among other pollutants. Dr. Rosenfeld also has experience evaluating greenhouse gas emissions from various projects and is an expert on the assessment of odors from industrial and agricultural sites, as well as the evaluation of odor nuisance impacts and technologies for abatement of odorous emissions. As a principal scientist at SWAPE, Dr. Rosenfeld directs air dispersion modeling and exposure assessments. He has served as an expert witness and testified about pollution sources causing nuisance and/or personal injury at dozens of sites and has testified as an expert witness on more than ten cases involving exposure to air contaminants from industrial sources.

Professional History:

Soil Water Air Protection Enterprise (SWAPE); 2003 to present; Principal and Founding Partner
UCLA School of Public Health; 2007 to 2011; Lecturer (Assistant Researcher)
UCLA School of Public Health; 2003 to 2006; Adjunct Professor
UCLA Environmental Science and Engineering Program; 2002-2004; Doctoral Intern Coordinator
UCLA Institute of the Environment, 2001-2002; Research Associate
Komex H₂O Science, 2001 to 2003; Senior Remediation Scientist
National Groundwater Association, 2002-2004; Lecturer
San Diego State University, 1999-2001; Adjunct Professor
Anteon Corp., San Diego, 2000-2001; Remediation Project Manager
Ogden (now Amec), San Diego, 2000-2000; Remediation Project Manager
Bechtel, San Diego, California, 1999 – 2000; Risk Assessor
King County, Seattle, 1996 – 1999; Scientist
James River Corp., Washington, 1995-96; Scientist
Big Creek Lumber, Davenport, California, 1995; Scientist
Plumas Corp., California and USFS, Tahoe 1993-1995; Scientist
Peace Corps and World Wildlife Fund, St. Kitts, West Indies, 1991-1993; Scientist

Publications:

Remy, L.L., Clay T., Byers, V., **Rosenfeld P. E.** (2019) Hospital, Health, and Community Burden After Oil Refinery Fires, Richmond, California 2007 and 2012. *Environmental Health*. 18:48

Simons, R.A., Seo, Y. **Rosenfeld, P.**, (2015) Modeling the Effect of Refinery Emission On Residential Property Value. *Journal of Real Estate Research*. 27(3):321-342

Chen, J. A, Zapata A. R., Sutherland A. J., Molmen, D.R., Chow, B. S., Wu, L. E., **Rosenfeld, P. E.**, Hesse, R. C., (2012) Sulfur Dioxide and Volatile Organic Compound Exposure To A Community In Texas City Texas Evaluated Using Aermol and Empirical Data. *American Journal of Environmental Science*, 8(6), 622-632.

Rosenfeld, P.E. & Feng, L. (2011). *The Risks of Hazardous Waste*. Amsterdam: Elsevier Publishing.

Cheremisinoff, N.P., & **Rosenfeld, P.E.** (2011). *Handbook of Pollution Prevention and Cleaner Production: Best Practices in the Agrochemical Industry*, Amsterdam: Elsevier Publishing.

Gonzalez, J., Feng, L., Sutherland, A., Waller, C., Sok, H., Hesse, R., **Rosenfeld, P.** (2010). PCBs and Dioxins/Furans in Attic Dust Collected Near Former PCB Production and Secondary Copper Facilities in Sauget, IL. *Procedia Environmental Sciences*. 113–125.

Feng, L., Wu, C., Tam, L., Sutherland, A.J., Clark, J.J., **Rosenfeld, P.E.** (2010). Dioxin and Furan Blood Lipid and Attic Dust Concentrations in Populations Living Near Four Wood Treatment Facilities in the United States. *Journal of Environmental Health*. 73(6), 34-46.

Cheremisinoff, N.P., & **Rosenfeld, P.E.** (2010). *Handbook of Pollution Prevention and Cleaner Production: Best Practices in the Wood and Paper Industries*. Amsterdam: Elsevier Publishing.

Cheremisinoff, N.P., & **Rosenfeld, P.E.** (2009). *Handbook of Pollution Prevention and Cleaner Production: Best Practices in the Petroleum Industry*. Amsterdam: Elsevier Publishing.

Wu, C., Tam, L., Clark, J., **Rosenfeld, P.** (2009). Dioxin and furan blood lipid concentrations in populations living near four wood treatment facilities in the United States. *WIT Transactions on Ecology and the Environment, Air Pollution*, 123 (17), 319-327.

Tam L. K., Wu C. D., Clark J. J. and **Rosenfeld, P.E.** (2008). A Statistical Analysis Of Attic Dust And Blood Lipid Concentrations Of Tetrachloro-p-Dibenzodioxin (TCDD) Toxicity Equivalency Quotients (TEQ) In Two Populations Near Wood Treatment Facilities. *Organohalogen Compounds*, 70, 002252-002255.

Tam L. K., Wu C. D., Clark J. J. and **Rosenfeld, P.E.** (2008). Methods For Collect Samples For Assessing Dioxins And Other Environmental Contaminants In Attic Dust: A Review. *Organohalogen Compounds*, 70, 000527-000530.

Hensley, A.R. A. Scott, J. J. J. Clark, **Rosenfeld, P.E.** (2007). Attic Dust and Human Blood Samples Collected near a Former Wood Treatment Facility. *Environmental Research*. 105, 194-197.

Rosenfeld, P.E., J. J. J. Clark, A. R. Hensley, M. Suffet. (2007). The Use of an Odor Wheel Classification for Evaluation of Human Health Risk Criteria for Compost Facilities. *Water Science & Technology* 55(5), 345-357.

Rosenfeld, P. E., M. Suffet. (2007). The Anatomy Of Odour Wheels For Odours Of Drinking Water, Wastewater, Compost And The Urban Environment. *Water Science & Technology* 55(5), 335-344.

Sullivan, P. J. Clark, J.J.J., Agardy, F. J., **Rosenfeld, P.E.** (2007). *Toxic Legacy, Synthetic Toxins in the Food, Water, and Air in American Cities*. Boston Massachusetts: Elsevier Publishing

Rosenfeld, P.E., and Suffet I.H. (2004). Control of Compost Odor Using High Carbon Wood Ash. *Water Science and Technology*. 49(9),171-178.

Rosenfeld P. E., J.J. Clark, I.H. (Mel) Suffet (2004). The Value of An Odor-Quality-Wheel Classification Scheme For The Urban Environment. *Water Environment Federation's Technical Exhibition and Conference (WEFTEC) 2004*. New Orleans, October 2-6, 2004.

Rosenfeld, P.E., and Suffet, I.H. (2004). Understanding Odorants Associated With Compost, Biomass Facilities, and the Land Application of Biosolids. *Water Science and Technology*. 49(9), 193-199.

Rosenfeld, P.E., and Suffet I.H. (2004). Control of Compost Odor Using High Carbon Wood Ash, *Water Science and Technology*, 49(9), 171-178.

Rosenfeld, P. E., Grey, M. A., Sellev, P. (2004). Measurement of Biosolids Odor and Odorant Emissions from Windrows, Static Pile and Biofilter. *Water Environment Research*. 76(4), 310-315.

Rosenfeld, P.E., Grey, M and Suffet, M. (2002). Compost Demonstration Project, Sacramento California Using High-Carbon Wood Ash to Control Odor at a Green Materials Composting Facility. *Integrated Waste Management Board Public Affairs Office, Publications Clearinghouse (MS-6)*, Sacramento, CA Publication #442-02-008.

Rosenfeld, P.E., and C.L. Henry. (2001). Characterization of odor emissions from three different biosolids. *Water Soil and Air Pollution*. 127(1-4), 173-191.

Rosenfeld, P.E., and Henry C. L., (2000). Wood ash control of odor emissions from biosolids application. *Journal of Environmental Quality*. 29, 1662-1668.

Rosenfeld, P.E., C.L. Henry and D. Bennett. (2001). Wastewater dewatering polymer affect on biosolids odor emissions and microbial activity. *Water Environment Research*. 73(4), 363-367.

Rosenfeld, P.E., and C.L. Henry. (2001). Activated Carbon and Wood Ash Sorption of Wastewater, Compost, and Biosolids Odorants. *Water Environment Research*, 73, 388-393.

Rosenfeld, P.E., and Henry C. L., (2001). High carbon wood ash effect on biosolids microbial activity and odor. *Water Environment Research*. 131(1-4), 247-262.

Chollack, T. and **P. Rosenfeld**. (1998). Compost Amendment Handbook For Landscaping. Prepared for and distributed by the City of Redmond, Washington State.

Rosenfeld, P. E. (1992). The Mount Liamuiga Crater Trail. *Heritage Magazine of St. Kitts*, 3(2).

Rosenfeld, P. E. (1993). High School Biogas Project to Prevent Deforestation On St. Kitts. *Biomass Users Network*, 7(1).

Rosenfeld, P. E. (1998). Characterization, Quantification, and Control of Odor Emissions From Biosolids Application To Forest Soil. Doctoral Thesis. University of Washington College of Forest Resources.

Rosenfeld, P. E. (1994). Potential Utilization of Small Diameter Trees on Sierra County Public Land. Masters thesis reprinted by the Sierra County Economic Council. Sierra County, California.

Rosenfeld, P. E. (1991). How to Build a Small Rural Anaerobic Digester & Uses Of Biogas In The First And Third World. Bachelors Thesis. University of California.

Presentations:

Rosenfeld, P.E., Sutherland, A; Hesse, R.; Zapata, A. (October 3-6, 2013). Air dispersion modeling of volatile organic emissions from multiple natural gas wells in Decatur, TX. *44th Western Regional Meeting, American Chemical Society*. Lecture conducted from Santa Clara, CA.

Sok, H.L.; Waller, C.C.; Feng, L.; Gonzalez, J.; Sutherland, A.J.; Wisdom-Stack, T.; Sahai, R.K.; Hesse, R.C.; **Rosenfeld, P.E.** (June 20-23, 2010). Atrazine: A Persistent Pesticide in Urban Drinking Water. *Urban Environmental Pollution*. Lecture conducted from Boston, MA.

Feng, L.; Gonzalez, J.; Sok, H.L.; Sutherland, A.J.; Waller, C.C.; Wisdom-Stack, T.; Sahai, R.K.; La, M.; Hesse, R.C.; **Rosenfeld, P.E.** (June 20-23, 2010). Bringing Environmental Justice to East St. Louis, Illinois. *Urban Environmental Pollution*. Lecture conducted from Boston, MA.

Rosenfeld, P.E. (April 19-23, 2009). Perfluorooctanoic Acid (PFOA) and Perfluorooctane Sulfonate (PFOS) Contamination in Drinking Water From the Use of Aqueous Film Forming Foams (AFFF) at Airports in the United States. *2009 Ground Water Summit and 2009 Ground Water Protection Council Spring Meeting*, Lecture conducted from Tuscon, AZ.

Rosenfeld, P.E. (April 19-23, 2009). Cost to Filter Atrazine Contamination from Drinking Water in the United States” Contamination in Drinking Water From the Use of Aqueous Film Forming Foams (AFFF) at Airports in the United States. *2009 Ground Water Summit and 2009 Ground Water Protection Council Spring Meeting*. Lecture conducted from Tuscon, AZ.

Wu, C., Tam, L., Clark, J., **Rosenfeld, P.** (20-22 July, 2009). Dioxin and furan blood lipid concentrations in populations living near four wood treatment facilities in the United States. Brebbia, C.A. and Popov, V., eds., *Air Pollution XVII: Proceedings of the Seventeenth International Conference on Modeling, Monitoring and Management of Air Pollution*. Lecture conducted from Tallinn, Estonia.

Rosenfeld, P. E. (October 15-18, 2007). Moss Point Community Exposure To Contaminants From A Releasing Facility. *The 23rd Annual International Conferences on Soils Sediment and Water*. Platform lecture conducted from University of Massachusetts, Amherst MA.

Rosenfeld, P. E. (October 15-18, 2007). The Repeated Trespass of Tritium-Contaminated Water Into A Surrounding Community Form Repeated Waste Spills From A Nuclear Power Plant. *The 23rd Annual International Conferences on Soils Sediment and Water*. Platform lecture conducted from University of Massachusetts, Amherst MA.

Rosenfeld, P. E. (October 15-18, 2007). Somerville Community Exposure To Contaminants From Wood Treatment Facility Emissions. The *23rd Annual International Conferences on Soils Sediment and Water*. Lecture conducted from University of Massachusetts, Amherst MA.

Rosenfeld P. E. (March 2007). Production, Chemical Properties, Toxicology, & Treatment Case Studies of 1,2,3-Trichloropropane (TCP). *The Association for Environmental Health and Sciences (AEHS) Annual Meeting*. Lecture conducted from San Diego, CA.

Rosenfeld P. E. (March 2007). Blood and Attic Sampling for Dioxin/Furan, PAH, and Metal Exposure in Florida, Alabama. *The AEHS Annual Meeting*. Lecture conducted from San Diego, CA.

Hensley A.R., Scott, A., **Rosenfeld P.E.**, Clark, J.J.J. (August 21 – 25, 2006). Dioxin Containing Attic Dust And Human Blood Samples Collected Near A Former Wood Treatment Facility. *The 26th International Symposium on Halogenated Persistent Organic Pollutants – DIOXIN2006*. Lecture conducted from Radisson SAS Scandinavia Hotel in Oslo Norway.

Hensley A.R., Scott, A., **Rosenfeld P.E.**, Clark, J.J.J. (November 4-8, 2006). Dioxin Containing Attic Dust And Human Blood Samples Collected Near A Former Wood Treatment Facility. *APHA 134 Annual Meeting & Exposition*. Lecture conducted from Boston Massachusetts.

Paul Rosenfeld Ph.D. (October 24-25, 2005). Fate, Transport and Persistence of PFOA and Related Chemicals. Mealey's C8/PFOA. *Science, Risk & Litigation Conference*. Lecture conducted from The Rittenhouse Hotel, Philadelphia, PA.

Paul Rosenfeld Ph.D. (September 19, 2005). Brominated Flame Retardants in Groundwater: Pathways to Human Ingestion, *Toxicology and Remediation PEMA Emerging Contaminant Conference*. Lecture conducted from Hilton Hotel, Irvine California.

Paul Rosenfeld Ph.D. (September 19, 2005). Fate, Transport, Toxicity, And Persistence of 1,2,3-TCP. *PEMA Emerging Contaminant Conference*. Lecture conducted from Hilton Hotel in Irvine, California.

Paul Rosenfeld Ph.D. (September 26-27, 2005). Fate, Transport and Persistence of PDBEs. *Mealey's Groundwater Conference*. Lecture conducted from Ritz Carlton Hotel, Marina Del Ray, California.

Paul Rosenfeld Ph.D. (June 7-8, 2005). Fate, Transport and Persistence of PFOA and Related Chemicals. *International Society of Environmental Forensics: Focus On Emerging Contaminants*. Lecture conducted from Sheraton Oceanfront Hotel, Virginia Beach, Virginia.

Paul Rosenfeld Ph.D. (July 21-22, 2005). Fate Transport, Persistence and Toxicology of PFOA and Related Perfluorochemicals. *2005 National Groundwater Association Ground Water And Environmental Law Conference*. Lecture conducted from Wyndham Baltimore Inner Harbor, Baltimore Maryland.

Paul Rosenfeld Ph.D. (July 21-22, 2005). Brominated Flame Retardants in Groundwater: Pathways to Human Ingestion, Toxicology and Remediation. *2005 National Groundwater Association Ground Water and Environmental Law Conference*. Lecture conducted from Wyndham Baltimore Inner Harbor, Baltimore Maryland.

Paul Rosenfeld, Ph.D. and James Clark Ph.D. and Rob Hesse R.G. (May 5-6, 2004). Tert-butyl Alcohol Liability and Toxicology, A National Problem and Unquantified Liability. *National Groundwater Association. Environmental Law Conference*. Lecture conducted from Congress Plaza Hotel, Chicago Illinois.

Paul Rosenfeld, Ph.D. (March 2004). Perchlorate Toxicology. *Meeting of the American Groundwater Trust*. Lecture conducted from Phoenix Arizona.

Hagemann, M.F., **Paul Rosenfeld, Ph.D.** and Rob Hesse (2004). Perchlorate Contamination of the Colorado River. *Meeting of tribal representatives*. Lecture conducted from Parker, AZ.

Paul Rosenfeld, Ph.D. (April 7, 2004). A National Damage Assessment Model For PCE and Dry Cleaners. *Drycleaner Symposium. California Ground Water Association*. Lecture conducted from Radison Hotel, Sacramento, California.

Rosenfeld, P. E., Grey, M., (June 2003) Two stage biofilter for biosolids composting odor control. *Seventh International In Situ And On Site Bioremediation Symposium Battelle Conference* Orlando, FL.

Paul Rosenfeld, Ph.D. and James Clark Ph.D. (February 20-21, 2003) Understanding Historical Use, Chemical Properties, Toxicity and Regulatory Guidance of 1,4 Dioxane. *National Groundwater Association. Southwest Focus Conference. Water Supply and Emerging Contaminants..* Lecture conducted from Hyatt Regency Phoenix Arizona.

Paul Rosenfeld, Ph.D. (February 6-7, 2003). Underground Storage Tank Litigation and Remediation. *California CUPA Forum*. Lecture conducted from Marriott Hotel, Anaheim California.

Paul Rosenfeld, Ph.D. (October 23, 2002) Underground Storage Tank Litigation and Remediation. *EPA Underground Storage Tank Roundtable*. Lecture conducted from Sacramento California.

Rosenfeld, P.E. and Suffet, M. (October 7- 10, 2002). Understanding Odor from Compost, *Wastewater and Industrial Processes. Sixth Annual Symposium On Off Flavors in the Aquatic Environment. International Water Association*. Lecture conducted from Barcelona Spain.

Rosenfeld, P.E. and Suffet, M. (October 7- 10, 2002). Using High Carbon Wood Ash to Control Compost Odor. *Sixth Annual Symposium On Off Flavors in the Aquatic Environment. International Water Association*. Lecture conducted from Barcelona Spain.

Rosenfeld, P.E. and Grey, M. A. (September 22-24, 2002). Biocycle Composting For Coastal Sage Restoration. *Northwest Biosolids Management Association*. Lecture conducted from Vancouver Washington..

Rosenfeld, P.E. and Grey, M. A. (November 11-14, 2002). Using High-Carbon Wood Ash to Control Odor at a Green Materials Composting Facility. *Soil Science Society Annual Conference*. Lecture conducted from Indianapolis, Maryland.

Rosenfeld, P.E. (September 16, 2000). Two stage biofilter for biosolids composting odor control. *Water Environment Federation*. Lecture conducted from Anaheim California.

Rosenfeld, P.E. (October 16, 2000). Wood ash and biofilter control of compost odor. *Biofest*. Lecture conducted from Ocean Shores, California.

Rosenfeld, P.E. (2000). Bioremediation Using Organic Soil Amendments. *California Resource Recovery Association*. Lecture conducted from Sacramento California.

Rosenfeld, P.E., C.L. Henry, R. Harrison. (1998). Oat and Grass Seed Germination and Nitrogen and Sulfur Emissions Following Biosolids Incorporation With High-Carbon Wood-Ash. *Water Environment Federation 12th Annual Residuals and Biosolids Management Conference Proceedings*. Lecture conducted from Bellevue Washington.

Rosenfeld, P.E., and C.L. Henry. (1999). An evaluation of ash incorporation with biosolids for odor reduction. *Soil Science Society of America*. Lecture conducted from Salt Lake City Utah.

Rosenfeld, P.E., C.L. Henry, R. Harrison. (1998). Comparison of Microbial Activity and Odor Emissions from Three Different Biosolids Applied to Forest Soil. *Brown and Caldwell*. Lecture conducted from Seattle Washington.

Rosenfeld, P.E., C.L. Henry. (1998). Characterization, Quantification, and Control of Odor Emissions from Biosolids Application To Forest Soil. *Biofest*. Lecture conducted from Lake Chelan, Washington.

Rosenfeld, P.E., C.L. Henry, R. Harrison. (1998). Oat and Grass Seed Germination and Nitrogen and Sulfur Emissions Following Biosolids Incorporation With High-Carbon Wood-Ash. Water Environment Federation 12th Annual Residuals and Biosolids Management Conference Proceedings. Lecture conducted from Bellevue Washington.

Rosenfeld, P.E., C.L. Henry, R. B. Harrison, and R. Dills. (1997). Comparison of Odor Emissions From Three Different Biosolids Applied to Forest Soil. *Soil Science Society of America*. Lecture conducted from Anaheim California.

Teaching Experience:

UCLA Department of Environmental Health (Summer 2003 through 20010) Taught Environmental Health Science 100 to students, including undergrad, medical doctors, public health professionals and nurses. Course focused on the health effects of environmental contaminants.

National Ground Water Association, Successful Remediation Technologies. Custom Course in Sante Fe, New Mexico. May 21, 2002. Focused on fate and transport of fuel contaminants associated with underground storage tanks.

National Ground Water Association; Successful Remediation Technologies Course in Chicago Illinois. April 1, 2002. Focused on fate and transport of contaminants associated with Superfund and RCRA sites.

California Integrated Waste Management Board, April and May, 2001. Alternative Landfill Caps Seminar in San Diego, Ventura, and San Francisco. Focused on both prescriptive and innovative landfill cover design.

UCLA Department of Environmental Engineering, February 5, 2002. Seminar on Successful Remediation Technologies focusing on Groundwater Remediation.

University Of Washington, Soil Science Program, Teaching Assistant for several courses including: Soil Chemistry, Organic Soil Amendments, and Soil Stability.

U.C. Berkeley, Environmental Science Program Teaching Assistant for Environmental Science 10.

Academic Grants Awarded:

California Integrated Waste Management Board. \$41,000 grant awarded to UCLA Institute of the Environment. Goal: To investigate effect of high carbon wood ash on volatile organic emissions from compost. 2001.

Synagro Technologies, Corona California: \$10,000 grant awarded to San Diego State University. Goal: investigate effect of biosolids for restoration and remediation of degraded coastal sage soils. 2000.

King County, Department of Research and Technology, Washington State. \$100,000 grant awarded to University of Washington: Goal: To investigate odor emissions from biosolids application and the effect of polymers and ash on VOC emissions. 1998.

Northwest Biosolids Management Association, Washington State. \$20,000 grant awarded to investigate effect of polymers and ash on VOC emissions from biosolids. 1997.

James River Corporation, Oregon: \$10,000 grant was awarded to investigate the success of genetically engineered Poplar trees with resistance to round-up. 1996.

United State Forest Service, Tahoe National Forest: \$15,000 grant was awarded to investigating fire ecology of the Tahoe National Forest. 1995.

Kellogg Foundation, Washington D.C. \$500 grant was awarded to construct a large anaerobic digester on St. Kitts in West Indies. 1993

Deposition and/or Trial Testimony:

- In the United States District Court For The District of New Jersey
Duarte et al, *Plaintiffs*, vs. United States Metals Refining Company et. al. *Defendant*.
Case No.: 2:17-cv-01624-ES-SCM
Rosenfeld Deposition. 6-7-2019
- In the United States District Court of Southern District of Texas Galveston Division
M/T Carla Maersk, *Plaintiffs*, vs. Conti 168., Schiffahrts-GMBH & Co. Bulker KG MS “Conti Perdido”
Defendant.
Case No.: 3:15-CV-00106 consolidated with 3:15-CV-00237
Rosenfeld Deposition. 5-9-2019
- In The Superior Court of the State of California In And For The County Of Los Angeles – Santa Monica
Carole-Taddeo-Bates et al., vs. Ifran Khan et al., Defendants
Case No.: No. BC615636
Rosenfeld Deposition, 1-26-2019
- In The Superior Court of the State of California In And For The County Of Los Angeles – Santa Monica
The San Gabriel Valley Council of Governments et al. vs El Adobe Apts. Inc. et al., Defendants
Case No.: No. BC646857
Rosenfeld Deposition, 10-6-2018; Trial 3-7-19
- In United States District Court For The District of Colorado
Bells et al. Plaintiff vs. The 3M Company et al., Defendants
Case: No 1:16-cv-02531-RBJ
Rosenfeld Deposition, 3-15-2018 and 4-3-2018
- In The District Court Of Regan County, Texas, 112th Judicial District
Phillip Bales et al., Plaintiff vs. Dow Agrosiences, LLC, et al., Defendants
Cause No 1923
Rosenfeld Deposition, 11-17-2017
- In The Superior Court of the State of California In And For The County Of Contra Costa
Simons et al., Plaintiffs vs. Chevron Corporation, et al., Defendants
Cause No C12-01481
Rosenfeld Deposition, 11-20-2017
- In The Circuit Court Of The Twentieth Judicial Circuit, St Clair County, Illinois
Martha Custer et al., Plaintiff vs. Cerro Flow Products, Inc., Defendants
Case No.: No. 0i9-L-2295
Rosenfeld Deposition, 8-23-2017
- In The Superior Court of the State of California, For The County of Los Angeles
Warrn Gilbert and Penny Gilber, Plaintiff vs. BMW of North America LLC
Case No.: LC102019 (c/w BC582154)
Rosenfeld Deposition, 8-16-2017, Trail 8-28-2018
- In the Northern District Court of Mississippi, Greenville Division
Brenda J. Cooper, et al., *Plaintiffs*, vs. Meritor Inc., et al., *Defendants*
Case Number: 4:16-cv-52-DMB-JVM
Rosenfeld Deposition: July 2017

In The Superior Court of the State of Washington, County of Snohomish
Michael Davis and Julie Davis et al., Plaintiff vs. Cedar Grove Composting Inc., Defendants
Case No.: No. 13-2-03987-5
Rosenfeld Deposition, February 2017
Trial, March 2017

In The Superior Court of the State of California, County of Alameda
Charles Spain., Plaintiff vs. Thermo Fisher Scientific, et al., Defendants
Case No.: RG14711115
Rosenfeld Deposition, September 2015

In The Iowa District Court In And For Poweshiek County
Russell D. Winburn, et al., Plaintiffs vs. Doug Hoksbergen, et al., Defendants
Case No.: LALA002187
Rosenfeld Deposition, August 2015

In The Iowa District Court For Wapello County
Jerry Dovico, et al., Plaintiffs vs. Valley View Sine LLC, et al., Defendants
Law No.: LALA105144 - Division A
Rosenfeld Deposition, August 2015

In The Iowa District Court For Wapello County
Doug Pauls, et al., et al., Plaintiffs vs. Richard Warren, et al., Defendants
Law No.: LALA105144 - Division A
Rosenfeld Deposition, August 2015

In The Circuit Court of Ohio County, West Virginia
Robert Andrews, et al. v. Antero, et al.
Civil Action NO. 14-C-30000
Rosenfeld Deposition, June 2015

In The Third Judicial District County of Dona Ana, New Mexico
Betty Gonzalez, et al. Plaintiffs vs. Del Oro Dairy, Del Oro Real Estate LLC, Jerry Settles and Deward
DeRuyter, Defendants
Rosenfeld Deposition: July 2015

In The Iowa District Court For Muscatine County
Laurie Freeman et. al. Plaintiffs vs. Grain Processing Corporation, Defendant
Case No 4980
Rosenfeld Deposition: May 2015

In the Circuit Court of the 17th Judicial Circuit, in and For Broward County, Florida
Walter Hinton, et. al. Plaintiff, vs. City of Fort Lauderdale, Florida, a Municipality, Defendant.
Case Number CACE07030358 (26)
Rosenfeld Deposition: December 2014

In the United States District Court Western District of Oklahoma
Tommy McCarty, et al., Plaintiffs, v. Oklahoma City Landfill, LLC d/b/a Southeast Oklahoma City
Landfill, et al. Defendants.
Case No. 5:12-cv-01152-C
Rosenfeld Deposition: July 2014

In the County Court of Dallas County Texas
Lisa Parr et al, *Plaintiff*, vs. Aruba et al, *Defendant*.
Case Number cc-11-01650-E
Rosenfeld Deposition: March and September 2013
Rosenfeld Trial: April 2014

In the Court of Common Pleas of Tuscarawas County Ohio
John Michael Abicht, et al., *Plaintiffs*, vs. Republic Services, Inc., et al., *Defendants*
Case Number: 2008 CT 10 0741 (Cons. w/ 2009 CV 10 0987)
Rosenfeld Deposition: October 2012

In the United States District Court of Southern District of Texas Galveston Division
Kyle Cannon, Eugene Donovan, Genaro Ramirez, Carol Sassler, and Harvey Walton, each Individually and on behalf of those similarly situated, *Plaintiffs*, vs. BP Products North America, Inc., *Defendant*.
Case 3:10-cv-00622
Rosenfeld Deposition: February 2012
Rosenfeld Trial: April 2013

In the Circuit Court of Baltimore County Maryland
Philip E. Cvach, II et al., *Plaintiffs* vs. Two Farms, Inc. d/b/a Royal Farms, Defendants
Case Number: 03-C-12-012487 OT
Rosenfeld Deposition: September 2013

EXHIBIT C



1640 5th St., Suite 204 Santa
Santa Monica, California 90401
Tel: (949) 887-9013
Email: mhagemann@swape.com

Matthew F. Hagemann, P.G., C.Hg., QSD, QSP

**Geologic and Hydrogeologic Characterization
Industrial Stormwater Compliance
Investigation and Remediation Strategies
Litigation Support and Testifying Expert
CEQA Review**

Education:

M.S. Degree, Geology, California State University Los Angeles, Los Angeles, CA, 1984.

B.A. Degree, Geology, Humboldt State University, Arcata, CA, 1982.

Professional Certifications:

California Professional Geologist

California Certified Hydrogeologist

Qualified SWPPP Developer and Practitioner

Professional Experience:

Matt has 25 years of experience in environmental policy, assessment and remediation. He spent nine years with the U.S. EPA in the RCRA and Superfund programs and served as EPA's Senior Science Policy Advisor in the Western Regional Office where he identified emerging threats to groundwater from perchlorate and MTBE. While with EPA, Matt also served as a Senior Hydrogeologist in the oversight of the assessment of seven major military facilities undergoing base closure. He led numerous enforcement actions under provisions of the Resource Conservation and Recovery Act (RCRA) while also working with permit holders to improve hydrogeologic characterization and water quality monitoring.

Matt has worked closely with U.S. EPA legal counsel and the technical staff of several states in the application and enforcement of RCRA, Safe Drinking Water Act and Clean Water Act regulations. Matt has trained the technical staff in the States of California, Hawaii, Nevada, Arizona and the Territory of Guam in the conduct of investigations, groundwater fundamentals, and sampling techniques.

Positions Matt has held include:

- Founding Partner, Soil/Water/Air Protection Enterprise (SWAPE) (2003 – present);
- Geology Instructor, Golden West College, 2010 – 2014;
- Senior Environmental Analyst, Komex H2O Science, Inc. (2000 -- 2003);

- Executive Director, Orange Coast Watch (2001 – 2004);
- Senior Science Policy Advisor and Hydrogeologist, U.S. Environmental Protection Agency (1989–1998);
- Hydrogeologist, National Park Service, Water Resources Division (1998 – 2000);
- Adjunct Faculty Member, San Francisco State University, Department of Geosciences (1993 – 1998);
- Instructor, College of Marin, Department of Science (1990 – 1995);
- Geologist, U.S. Forest Service (1986 – 1998); and
- Geologist, Dames & Moore (1984 – 1986).

Senior Regulatory and Litigation Support Analyst:

With SWAPE, Matt’s responsibilities have included:

- Lead analyst and testifying expert in the review of over 100 environmental impact reports since 2003 under CEQA that identify significant issues with regard to hazardous waste, water resources, water quality, air quality, Valley Fever, greenhouse gas emissions, and geologic hazards. Make recommendations for additional mitigation measures to lead agencies at the local and county level to include additional characterization of health risks and implementation of protective measures to reduce worker exposure to hazards from toxins and Valley Fever.
- Stormwater analysis, sampling and best management practice evaluation at industrial facilities.
- Manager of a project to provide technical assistance to a community adjacent to a former Naval shipyard under a grant from the U.S. EPA.
- Technical assistance and litigation support for vapor intrusion concerns.
- Lead analyst and testifying expert in the review of environmental issues in license applications for large solar power plants before the California Energy Commission.
- Manager of a project to evaluate numerous formerly used military sites in the western U.S.
- Manager of a comprehensive evaluation of potential sources of perchlorate contamination in Southern California drinking water wells.
- Manager and designated expert for litigation support under provisions of Proposition 65 in the review of releases of gasoline to sources drinking water at major refineries and hundreds of gas stations throughout California.
- Expert witness on two cases involving MTBE litigation.
- Expert witness and litigation support on the impact of air toxins and hazards at a school.
- Expert witness in litigation at a former plywood plant.

With Komex H2O Science Inc., Matt’s duties included the following:

- Senior author of a report on the extent of perchlorate contamination that was used in testimony by the former U.S. EPA Administrator and General Counsel.
- Senior researcher in the development of a comprehensive, electronically interactive chronology of MTBE use, research, and regulation.
- Senior researcher in the development of a comprehensive, electronically interactive chronology of perchlorate use, research, and regulation.
- Senior researcher in a study that estimates nationwide costs for MTBE remediation and drinking water treatment, results of which were published in newspapers nationwide and in testimony against provisions of an energy bill that would limit liability for oil companies.
- Research to support litigation to restore drinking water supplies that have been contaminated by MTBE in California and New York.

- Expert witness testimony in a case of oil production-related contamination in Mississippi.
- Lead author for a multi-volume remedial investigation report for an operating school in Los Angeles that met strict regulatory requirements and rigorous deadlines.

- Development of strategic approaches for cleanup of contaminated sites in consultation with clients and regulators.

Executive Director:

As Executive Director with Orange Coast Watch, Matt led efforts to restore water quality at Orange County beaches from multiple sources of contamination including urban runoff and the discharge of wastewater. In reporting to a Board of Directors that included representatives from leading Orange County universities and businesses, Matt prepared issue papers in the areas of treatment and disinfection of wastewater and control of the discharge of grease to sewer systems. Matt actively participated in the development of countywide water quality permits for the control of urban runoff and permits for the discharge of wastewater. Matt worked with other nonprofits to protect and restore water quality, including Surfrider, Natural Resources Defense Council and Orange County CoastKeeper as well as with business institutions including the Orange County Business Council.

Hydrogeology:

As a Senior Hydrogeologist with the U.S. Environmental Protection Agency, Matt led investigations to characterize and cleanup closing military bases, including Mare Island Naval Shipyard, Hunters Point Naval Shipyard, Treasure Island Naval Station, Alameda Naval Station, Moffett Field, Mather Army Airfield, and Sacramento Army Depot. Specific activities were as follows:

- Led efforts to model groundwater flow and contaminant transport, ensured adequacy of monitoring networks, and assessed cleanup alternatives for contaminated sediment, soil, and groundwater.
- Initiated a regional program for evaluation of groundwater sampling practices and laboratory analysis at military bases.
- Identified emerging issues, wrote technical guidance, and assisted in policy and regulation development through work on four national U.S. EPA workgroups, including the Superfund Groundwater Technical Forum and the Federal Facilities Forum.

At the request of the State of Hawaii, Matt developed a methodology to determine the vulnerability of groundwater to contamination on the islands of Maui and Oahu. He used analytical models and a GIS to show zones of vulnerability, and the results were adopted and published by the State of Hawaii and County of Maui.

As a hydrogeologist with the EPA Groundwater Protection Section, Matt worked with provisions of the Safe Drinking Water Act and NEPA to prevent drinking water contamination. Specific activities included the following:

- Received an EPA Bronze Medal for his contribution to the development of national guidance for the protection of drinking water.
- Managed the Sole Source Aquifer Program and protected the drinking water of two communities through designation under the Safe Drinking Water Act. He prepared geologic reports, conducted public hearings, and responded to public comments from residents who were very concerned about the impact of designation.

- Reviewed a number of Environmental Impact Statements for planned major developments, including large hazardous and solid waste disposal facilities, mine reclamation, and water transfer.

Matt served as a hydrogeologist with the RCRA Hazardous Waste program. Duties were as follows:

- Supervised the hydrogeologic investigation of hazardous waste sites to determine compliance with Subtitle C requirements.
- Reviewed and wrote "part B" permits for the disposal of hazardous waste.
- Conducted RCRA Corrective Action investigations of waste sites and led inspections that formed the basis for significant enforcement actions that were developed in close coordination with U.S. EPA legal counsel.
- Wrote contract specifications and supervised contractor's investigations of waste sites.

With the National Park Service, Matt directed service-wide investigations of contaminant sources to prevent degradation of water quality, including the following tasks:

- Applied pertinent laws and regulations including CERCLA, RCRA, NEPA, NRDA, and the Clean Water Act to control military, mining, and landfill contaminants.
- Conducted watershed-scale investigations of contaminants at parks, including Yellowstone and Olympic National Park.
- Identified high-levels of perchlorate in soil adjacent to a national park in New Mexico and advised park superintendent on appropriate response actions under CERCLA.
- Served as a Park Service representative on the Interagency Perchlorate Steering Committee, a national workgroup.
- Developed a program to conduct environmental compliance audits of all National Parks while serving on a national workgroup.
- Co-authored two papers on the potential for water contamination from the operation of personal watercraft and snowmobiles, these papers serving as the basis for the development of nation-wide policy on the use of these vehicles in National Parks.
- Contributed to the Federal Multi-Agency Source Water Agreement under the Clean Water Action Plan.

Policy:

Served senior management as the Senior Science Policy Advisor with the U.S. Environmental Protection Agency, Region 9. Activities included the following:

- Advised the Regional Administrator and senior management on emerging issues such as the potential for the gasoline additive MTBE and ammonium perchlorate to contaminate drinking water supplies.
- Shaped EPA's national response to these threats by serving on workgroups and by contributing to guidance, including the Office of Research and Development publication, *Oxygenates in Water: Critical Information and Research Needs*.
- Improved the technical training of EPA's scientific and engineering staff.
- Earned an EPA Bronze Medal for representing the region's 300 scientists and engineers in negotiations with the Administrator and senior management to better integrate scientific principles into the policy-making process.
- Established national protocol for the peer review of scientific documents.

Geology:

With the U.S. Forest Service, Matt led investigations to determine hillslope stability of areas proposed for timber harvest in the central Oregon Coast Range. Specific activities were as follows:

- Mapped geology in the field, and used aerial photographic interpretation and mathematical models to determine slope stability.
- Coordinated his research with community members who were concerned with natural resource protection.
- Characterized the geology of an aquifer that serves as the sole source of drinking water for the city of Medford, Oregon.

As a consultant with Dames and Moore, Matt led geologic investigations of two contaminated sites (later listed on the Superfund NPL) in the Portland, Oregon, area and a large hazardous waste site in eastern Oregon. Duties included the following:

- Supervised year-long effort for soil and groundwater sampling.
- Conducted aquifer tests.
- Investigated active faults beneath sites proposed for hazardous waste disposal.

Teaching:

From 1990 to 1998, Matt taught at least one course per semester at the community college and university levels:

- At San Francisco State University, held an adjunct faculty position and taught courses in environmental geology, oceanography (lab and lecture), hydrogeology, and groundwater contamination.
- Served as a committee member for graduate and undergraduate students.
- Taught courses in environmental geology and oceanography at the College of Marin.

Matt taught physical geology (lecture and lab and introductory geology at Golden West College in Huntington Beach, California from 2010 to 2014.

Invited Testimony, Reports, Papers and Presentations:

Hagemann, M.F., 2008. Disclosure of Hazardous Waste Issues under CEQA. Presentation to the Public Environmental Law Conference, Eugene, Oregon.

Hagemann, M.F., 2008. Disclosure of Hazardous Waste Issues under CEQA. Invited presentation to U.S. EPA Region 9, San Francisco, California.

Hagemann, M.F., 2005. Use of Electronic Databases in Environmental Regulation, Policy Making and Public Participation. Brownfields 2005, Denver, Colorado.

Hagemann, M.F., 2004. Perchlorate Contamination of the Colorado River and Impacts to Drinking Water in Nevada and the Southwestern U.S. Presentation to a meeting of the American Groundwater Trust, Las Vegas, NV (served on conference organizing committee).

Hagemann, M.F., 2004. Invited testimony to a California Senate committee hearing on air toxins at schools in Southern California, Los Angeles.

Brown, A., Farrow, J., Gray, A. and **Hagemann, M.**, 2004. An Estimate of Costs to Address MTBE Releases from Underground Storage Tanks and the Resulting Impact to Drinking Water Wells. Presentation to the Ground Water and Environmental Law Conference, National Groundwater Association.

Hagemann, M.F., 2004. Perchlorate Contamination of the Colorado River and Impacts to Drinking Water in Arizona and the Southwestern U.S. Presentation to a meeting of the American Groundwater Trust, Phoenix, AZ (served on conference organizing committee).

Hagemann, M.F., 2003. Perchlorate Contamination of the Colorado River and Impacts to Drinking Water in the Southwestern U.S. Invited presentation to a special committee meeting of the National Academy of Sciences, Irvine, CA.

Hagemann, M.F., 2003. Perchlorate Contamination of the Colorado River. Invited presentation to a tribal EPA meeting, Pechanga, CA.

Hagemann, M.F., 2003. Perchlorate Contamination of the Colorado River. Invited presentation to a meeting of tribal representatives, Parker, AZ.

Hagemann, M.F., 2003. Impact of Perchlorate on the Colorado River and Associated Drinking Water Supplies. Invited presentation to the Inter-Tribal Meeting, Torres Martinez Tribe.

Hagemann, M.F., 2003. The Emergence of Perchlorate as a Widespread Drinking Water Contaminant. Invited presentation to the U.S. EPA Region 9.

Hagemann, M.F., 2003. A Deductive Approach to the Assessment of Perchlorate Contamination. Invited presentation to the California Assembly Natural Resources Committee.

Hagemann, M.F., 2003. Perchlorate: A Cold War Legacy in Drinking Water. Presentation to a meeting of the National Groundwater Association.

Hagemann, M.F., 2002. From Tank to Tap: A Chronology of MTBE in Groundwater. Presentation to a meeting of the National Groundwater Association.

Hagemann, M.F., 2002. A Chronology of MTBE in Groundwater and an Estimate of Costs to Address Impacts to Groundwater. Presentation to the annual meeting of the Society of Environmental Journalists.

Hagemann, M.F., 2002. An Estimate of the Cost to Address MTBE Contamination in Groundwater (and Who Will Pay). Presentation to a meeting of the National Groundwater Association.

Hagemann, M.F., 2002. An Estimate of Costs to Address MTBE Releases from Underground Storage Tanks and the Resulting Impact to Drinking Water Wells. Presentation to a meeting of the U.S. EPA and State Underground Storage Tank Program managers.

Hagemann, M.F., 2001. From Tank to Tap: A Chronology of MTBE in Groundwater. Unpublished report.

Hagemann, M.F., 2001. Estimated Cleanup Cost for MTBE in Groundwater Used as Drinking Water. Unpublished report.

Hagemann, M.F., 2001. Estimated Costs to Address MTBE Releases from Leaking Underground Storage Tanks. Unpublished report.

Hagemann, M.F., and VanMouwerik, M., 1999. Potential Water Quality Concerns Related to Snowmobile Usage. Water Resources Division, National Park Service, Technical Report.

VanMouwerik, M. and **Hagemann, M.F.** 1999, Water Quality Concerns Related to Personal Watercraft Usage. Water Resources Division, National Park Service, Technical Report.

Hagemann, M.F., 1999, Is Dilution the Solution to Pollution in National Parks? The George Wright Society Biannual Meeting, Asheville, North Carolina.

Hagemann, M.F., 1997, The Potential for MTBE to Contaminate Groundwater. U.S. EPA Superfund Groundwater Technical Forum Annual Meeting, Las Vegas, Nevada.

Hagemann, M.F., and Gill, M., 1996, Impediments to Intrinsic Remediation, Moffett Field Naval Air Station, Conference on Intrinsic Remediation of Chlorinated Hydrocarbons, Salt Lake City.

Hagemann, M.F., Fukunaga, G.L., 1996, The Vulnerability of Groundwater to Anthropogenic Contaminants on the Island of Maui, Hawaii. Hawaii Water Works Association Annual Meeting, Maui, October 1996.

Hagemann, M. F., Fukanaga, G. L., 1996, Ranking Groundwater Vulnerability in Central Oahu, Hawaii. Proceedings, Geographic Information Systems in Environmental Resources Management, Air and Waste Management Association Publication VIP-61.

Hagemann, M.F., 1994. Groundwater Characterization and Cleanup at Closing Military Bases in California. Proceedings, California Groundwater Resources Association Meeting.

Hagemann, M.F. and Sabol, M.A., 1993. Role of the U.S. EPA in the High Plains States Groundwater Recharge Demonstration Program. Proceedings, Sixth Biennial Symposium on the Artificial Recharge of Groundwater.

Hagemann, M.F., 1993. U.S. EPA Policy on the Technical Impracticability of the Cleanup of DNAPL-contaminated Groundwater. California Groundwater Resources Association Meeting.

Hagemann, M.F., 1992. Dense Nonaqueous Phase Liquid Contamination of Groundwater: An Ounce of Prevention... Proceedings, Association of Engineering Geologists Annual Meeting, v. 35.

Other Experience:

Selected as subject matter expert for the California Professional Geologist licensing examination, 2009-2011.

Los Angeles Department of Building and Safety

Certificate Information: 1200 N VINE ST 90038

Application / Permit	22010-10000-05021
Plan Check / Job No.	B22LA20609
Group	Building
Type	Bldg-New
Sub-Type	Commercial
Primary Use	(5) Apartment
Work Description	**** HSAP TO CHECK FOR ZONING REQUIREMENTS ONLY - (SB330) **** NEW 7 STORY 151 UNITS (11% AFFORDABLE 17UNITS) MIXED USE AFFORDABLE HOUSING APARTMENT TO INCLUDE 5 STORY TYPE IIIA APARTMENT OVER 1 STORY TYPE IA APARTMENT/PARKING OVER 1 STORY TYPE IA RETAIL/PARKING, 12.22.A.25 / AB2345 WITH ADDITIONAL INCENTIVE
Permit Issued	No
Current Status	Verifications in Progress on 12/27/2022

Permit Application Status History

Submitted	10/13/2022	APPLICANT
Assigned to Plan Check Engineer	10/20/2022	ARMEN JIVALAGIAN
Corrections Issued	10/24/2022	ARMEN JIVALAGIAN
Reviewed by Supervisor	11/15/2022	MINYE PAK
Applicant returned to address corrections	12/21/2022	ARMEN JIVALAGIAN
Applicant returned to address corrections	12/27/2022	ARMEN JIVALAGIAN

Permit Application Clearance Information

"D" conditions	Not Cleared	10/24/2022	City Planning Department
Address approval	Not Cleared	10/24/2022	Bureau of Engineering
Bicycle Parking	Not Cleared	10/24/2022	Bureau of Engineering
Building over 36-ft	Not Cleared	10/24/2022	Cal Occ. Safety and Health Administration
CPC	Not Cleared	10/24/2022	City Planning Department
Construction near power lines	Not Cleared	10/24/2022	Department of Water and Power
Construction within easement	Not Cleared	10/24/2022	Department of Water and Power
DAS Clearance	Not Cleared	10/24/2022	Department of Building and Safety
DCP conditions approval	Not Cleared	10/24/2022	Los Angeles Housing Department
Density Bonus	Not Cleared	10/24/2022	Los Angeles Housing Department
Driveway location	Not Cleared	10/24/2022	Department of Transportation
Encroachment in public way	Not Cleared	10/24/2022	Bureau of Engineering
Eng Process Fee Ord 176,300	Not Cleared	10/24/2022	Bureau of Engineering
Excavation more than 5-ft deep	Not Cleared	10/24/2022	Cal Occ. Safety and Health Administration
Fire Marshal Fire Life Safety	Not Cleared	10/24/2022	Los Angeles Fire Department
Green Code	Not Cleared	10/24/2022	Department of Building and Safety
Highway dedication	Not Cleared	10/24/2022	Bureau of Engineering
Hydrant and Access approval	Not Cleared	10/24/2022	Los Angeles Fire Department
Internal circulation	Not Cleared	10/24/2022	Department of Transportation
Low Impact Development	Not Cleared	10/24/2022	Bureau of Sanitation
Opn space landscape/Water mgmt	Not Cleared	10/24/2022	City Planning Department

Permit	Not Cleared	10/24/2022	Bureau of Engineering
Roof/Waste drainage to street	Not Cleared	10/24/2022	Bureau of Engineering
Sewer availability	Not Cleared	10/24/2022	Bureau of Engineering
Site Plan review	Not Cleared	10/24/2022	City Planning Department
Trees in Parkway	Not Cleared	10/24/2022	Bureau of Street Services
Work Adjacent to Public Way	Not Cleared	10/24/2022	Bureau of Engineering
ZA Case	Not Cleared	10/24/2022	City Planning Department
ZA Case	Not Cleared	10/24/2022	City Planning Department
ZA Case	Not Cleared	10/24/2022	City Planning Department
ZI	Not Cleared	10/24/2022	City Planning Department

Contact Information

No Data Available.

Inspector Information

No Data Available.

Pending Inspections

No Data Available.

Inspection Request History

No Data Available.